

FCC Radio Test Report

FCC ID : G95BGW620
Equipment : Wi-Fi 7 XGS-PON Gateway
Brand Name : ARRIS
Model Name : BGW620-700
Applicant : Vantiva USA LLC
4855 Peachtree Industrial Blvd. Suite 200, Norcross,
Georgia, 30092 United States
Manufacturer : Vantiva
887 N Douglas street, El Segundo CA 90245
Standard : 47 CFR FCC Part 15.247

The product was received on May 09, 2024, and testing was started from May 15, 2024 and completed on Jul. 23, 2024. We, SPORTON INTERNATIONAL INC. Hsinhua Laboratory, would like to declare that the tested sample has been evaluated in accordance with the procedures given in ANSI C63.10-2013 and shown compliance with the applicable technical standards.

The test results in this report apply exclusively to the tested model / sample. Without written approval of SPORTON INTERNATIONAL INC. Hsinhua Laboratory, the test report shall not be reproduced except in full.



Approved by: Jackson Tsai

SPORTON INTERNATIONAL INC. Hsinhua Laboratory

No.52, Huaya 1st Rd., Guishan Dist., Taoyuan City 333411, Taiwan (R.O.C.)



Table of Contents

HISTORY OF THIS TEST REPORT3

SUMMARY OF TEST RESULT4

1 GENERAL DESCRIPTION5

1.1 Information.....5

1.2 Testing Applied Standards8

1.3 Testing Location Information8

1.4 Measurement Uncertainty8

2 TEST CONFIGURATION OF EUT.....9

2.1 Test Channel Mode9

2.2 The Worst Case Measurement Configuration.....10

2.3 Accessories11

2.4 Support Equipment.....11

2.5 Test Setup Diagram11

3 TRANSMITTER TEST RESULT13

3.1 AC Power-line Conducted Emissions13

3.2 DTS Bandwidth.....15

3.3 Maximum Conducted Output Power16

3.4 Power Spectral Density18

3.5 Emissions in Non-restricted Frequency Bands19

3.6 Emissions in Restricted Frequency Bands.....20

4 TEST EQUIPMENT AND CALIBRATION DATA.....24

APPENDIX A. TEST RESULTS OF AC POWER-LINE CONDUCTED EMISSIONS

APPENDIX B. TEST RESULTS OF DTS BANDWIDTH

APPENDIX C. TEST RESULTS OF MAXIMUM CONDUCTED OUTPUT POWER

APPENDIX D. TEST RESULTS OF POWER SPECTRAL DENSITY

APPENDIX E. TEST RESULTS OF EMISSIONS IN NON-RESTRICTED FREQUENCY BANDS

APPENDIX F. TEST RESULTS OF EMISSIONS IN RESTRICTED FREQUENCY BANDS

APPENDIX G. TEST RESULTS OF RADIATED EMISSION CO-LOCATION

APPENDIX H. TEST PHOTOS

PHOTOGRAPHS OF EUT V01



History of this test report

Report No.	Version	Description	Issued Date
FR450601AL	01	Initial issue of report	Aug. 08, 2024



Summary of Test Result

Report Clause	Ref.Std. Clause	Test Items	Result (PASS/FAIL)	Remark
1.1.2	15.203	Antenna Requirement	PASS	-
3.1	15.207	AC Power-line Conducted Emissions	PASS	-
3.2	15.247(a)	DTS Bandwidth	PASS	-
3.3	15.247(b)	Maximum Conducted Output Power	PASS	-
3.4	15.247(e)	Power Spectral Density	PASS	-
3.5	15.247(d)	Emissions in Non-restricted Frequency Bands	PASS	-
3.6	15.247(d)	Emissions in Restricted Frequency Bands	PASS	-

Declaration of Conformity:
The test results with all measurement uncertainty excluded are presented in accordance with the regulation limits or requirements declared by manufacturers.
Comments and explanations:
None

Reviewed by: Barry Hsiao

Report Producer: Ann Hou



1 General Description

1.1 Information

1.1.1 RF General Information

Frequency Range (MHz)	Bluetooth Mode	Ch. Frequency (MHz)	Channel Number
2400-2483.5	LE	2402-2480	0-39 [40]

Band	Mode	BWch (MHz)	Nant
2.4-2.4835GHz	BT-LE(125kbps)	1.0	1TX
2.4-2.4835GHz	BT-LE(500kbps)	1.0	1TX
2.4-2.4835GHz	BT-LE(1Mbps)	1.0	1TX
2.4-2.4835GHz	BT-LE(2Mbps)	2.0	1TX

Note:

- ♦ Bluetooth LE uses a GFSK (125kbps/500kbps/1Mbps/2Mbps) modulation.
- ♦ BWch is the nominal channel bandwidth.

1.1.2 Antenna Information

Ant.	Brand	Model Name	Antenna Type	Connector	Support
1	Galtronics	DB1	PCB	I-Pex	2.4G+5G
2	Galtronics	DB2	PCB	I-Pex	2.4G+5G
3	Galtronics	DB3	PCB	I-Pex	2.4G+5G
4	Galtronics	DB4	PCB	I-Pex	2.4G+5G
5	Galtronics	6G1	PCB	I-Pex	6G
6	Galtronics	6G2	PCB	I-Pex	6G
7	Galtronics	6G3	PCB	I-Pex	6G
8	Galtronics	6G4	PCB	I-Pex	6G
9	Galtronics	IoT1-DFS	PCB	I-Pex	5G/BT/802.15.4
10	Galtronics	IoT2	PCB	I-Pex	BT/802.15.4
11	Galtronics	GNSS	PCB	I-Pex	GPS

Ant.	Port	Gain (dBi)											
		2.4G	UNII-1	UNII-2A	UNII-2C	UNII-3	UNII-5	UNII-6	UNII-7	UNII-8	DFS-RX	BT+802.15.4	GPS
1	1	3.54	4.9	4.94	5.12	5.02	-	-	-	-	-	-	-
2	2	4.79	3.47	3.79	3.58	2.66	-	-	-	-	-	-	-
3	3	3.46	2.48	2.72	4.85	4.02	-	-	-	-	-	-	-
4	4	3.75	4.41	3.05	3.46	3.78	-	-	-	-	-	-	-



Ant.	Port	Gain (dBi)											
		2.4G	UNII-1	UNII-2A	UNII-2C	UNII-3	UNII-5	UNII-6	UNII-7	UNII-8	DFS-RX	BT+802.15.4	GPS
5	1	-	-	-	-	-	4	4.85	4.11	4.22	-	-	-
6	2	-	-	-	-	-	3.64	4.26	3.26	4.19	-	-	-
7	3	-	-	-	-	-	5.5	5.4	4.77	5.07	-	-	-
8	4	-	-	-	-	-	5.11	5.04	4.96	5.17	-	-	-
9	1	-	-	-	-	-	-	-	-	-	5.647	4.716	-
10	2	-	-	-	-	-	-	-	-	-	-	3.765	-
11	1	-	-	-	-	-	-	-	-	-	-	-	4.219

Composite Gain (dBi)										
Freq(Hz)	2.45G	5.2G	5.3G	5.6G	5.785G	6.175G	6.475G	6.695G	6.995G	
DG [1SS] (dBi)	5.03	5.25	5.58	6.35	6.17	5.66	5.88	5.63	5.82	
DG [2SS] (dBi)	4.79	4.9	4.94	5.12	5.02	5.5	5.4	4.96	5.17	
DG [4SS] (dBi)	4.79	4.9	4.94	5.12	5.02	5.5	5.4	4.96	5.17	

Note 1: The EUT has eleven antennas.

Note 2: The composite gain is derived as KDB 662911 D03 v01 which was used as directional gain. For more detail information, please refer to the Antenna Pattern Report AP450601.

For 2.4GHz function:

For IEEE 802.11 b/g/n/VHT/ax/be mode (4TX/4RX)

Ant. 1 (port 1), Ant. 2 (port 2), Ant. 3 (port 3) and Ant. 4 (port 4) could transmit/receive simultaneously.

For 5GHz function:

For IEEE 802.11 a/n/ac/ax/be mode (4TX/5RX)

Ant. 1 (port 1), Ant. 2 (port 2), Ant. 3 (port 3) and Ant. 4 (port 4) could transmit simultaneously.

Ant. 1 (port 1), Ant. 2 (port 2), Ant. 3 (port 3), Ant. 4 (port 4) and Ant. 9 (port 1) could receive simultaneously.

For 6GHz function:

For IEEE 802.11 ax/be mode (4TX/4RX)

Ant. 5 (port 1), Ant. 6 (port 2), Ant. 7 (port 3) and Ant. 8 (port 4) could transmit/receive simultaneously.

For BT function:

For IEEE 802.15.1 Bluetooth mode (1TX/1RX)

Ant. 9 (port 1) or Ant. 10 (port 2) could transmit/receive.

Support diversity function and pre-tested on each single chain, the worst case was Ant. 10(port 2) and it was record in this test report.

For 802.15.4 function:

For IEEE 802.15.4 mode (1TX/1RX)

Ant. 9 (port 1) or Ant. 10 (port 2) could transmit/receive.

Support diversity function and pre-tested on each single chain, the worst case was Ant. 10(port 2) and it was record in this test report.

For GPS function:

For GNSS mode (1TX/1RX)

Ant. 11 (port 1) could transmit/receive.



1.1.3 EUT Information

Operational Condition	
EUT Power Type	From AC Adapter
EUT Function	<input checked="" type="checkbox"/> Point-to-multipoint <input type="checkbox"/> Point-to-point
Type of EUT	
<input checked="" type="checkbox"/> Stand-alone	
<input type="checkbox"/> Combined (EUT where the radio part is fully integrated within another device)	
<input type="checkbox"/> Combined Equipment - Brand Name / Model No.:	...
<input type="checkbox"/> Plug-in radio (EUT intended for a variety of host systems)	
<input type="checkbox"/> Host System - Brand Name / Model No.:	...
<input type="checkbox"/> Other:	

1.1.4 Mode Test Duty Cycle

Mode	DC	DCF (dB)	T (s)	VBW (Hz)_1/T
BT-LE(125kbps)	0.829	0.81	3.108m	1k
BT-LE(500kbps)	0.574	2.41	1.076m	1k
BT-LE(1Mbps)	0.633	1.99	396.562u	3k
BT-LE(2Mbps)	0.337	4.72	210.937u	10k

Note. If DC < 0.98, the DCF was added while measuring Output power and PSD.

1.2 Testing Applied Standards

According to the specifications of the manufacturer, the EUT must comply with the requirements of the following standards:

- ♦ 47 CFR FCC Part 15
- ♦ ANSI C63.10-2013

The following reference test guidance is not within the scope of accreditation of TAF:

- ♦ KDB 558074 D01 v05r02
- ♦ KDB 414788 D01 v01r01

1.3 Testing Location Information

Test Lab. : Sporton International Inc. Hsinhua Laboratory				
<input checked="" type="checkbox"/>	Hsinhua (TAF: 3785)	ADD: No.52, Huaya 1st Rd., Guishan Dist., Taoyuan City 333411, Taiwan (R.O.C.)		
		TEL: 886-3-327-3456	FAX: 886-3-327-0973	
Test site Designation No. TW3785 with FCC.				
Test Condition	Test Site No.	Test Engineer	Test Environment	Test Date
AC Conduction	CO04-HY	Wayne Chiu	23.4~23.7°C / 53~55%	05/Jun/2024
RF Conducted	TH07-HY	Yuna Lin	21.8~23.7°C / 52~61%	15/May/2024~23/Jul/2024
<input checked="" type="checkbox"/>	Wenhua 3rd. (TAF: 3785)	ADD: No. 58, Aly. 75, Ln. 564, Wenhua 3rd Rd., Guishan Dist. Taoyuan City 333, Taiwan (R.O.C.)		
		TEL: 886-3-327-0868		
Test site Designation No. TW0036 with FCC.				
Test Condition	Test Site No.	Test Engineer	Test Environment	Test Date
Radiated	03CH25-HY	Simon Cheng	22.3~23.1°C / 52~54%	15/May/2024~23/Jul/2024
Radiated (Co-location)	03CH25-HY	Lego Lin	22.2~23.4°C / 50~52%	01/Jun/2024

1.4 Measurement Uncertainty

ISO/IEC 17025 requires that an estimate of the measurement uncertainties associated with the emissions test results be included in the report. The measurement uncertainties given below are based on a 95% confidence level (based on a coverage factor (k=2))

Test Items	Uncertainty	Remark
AC Power-line Conducted Emissions	4.53 dB	Confidence levels of 95%
Bandwidth	3 MHz	Confidence levels of 95%
Maximum Conducted Output Power	2 dB	Confidence levels of 95%
Power Spectral Density	2 dB	Confidence levels of 95%
Emissions in Non-restricted Frequency Bands	0.14 dB	Confidence levels of 95%
Emissions in Restricted Frequency Bands	4.8 dB	Confidence levels of 95%
Temperature	0.41 °C	Confidence levels of 95%
Humidity	3.4 %	Confidence levels of 95%



2 Test Configuration of EUT

2.1 Test Channel Mode



Test Software Version	Dos6.1
-----------------------	--------

Mode	Power Setting
BT-LE(125kbps)	-
2402MHz	17
2440MHz	17
2480MHz	18
BT-LE(500kbps)	-
2402MHz	20
2440MHz	20
2480MHz	20
BT-LE(1Mbps)	-
2402MHz	20
2440MHz	20
2480MHz	20
BT-LE(2Mbps)	-
2402MHz	20
2440MHz	20
2478MHz	20
2480MHz	17

2.2 The Worst Case Measurement Configuration

The Worst Case Mode for Following Conformance Tests	
Tests Item	AC power-line conducted emissions
Condition	AC power-line conducted measurement for line and neutral Test Voltage: 120Vac / 60Hz
Operating Mode	CTX
1	Adapter mode

The Worst Case Mode for Following Conformance Tests	
Tests Item	DTS Bandwidth Maximum Conducted Output Power Power Spectral Density Emissions in Non-restricted Frequency Bands
Test Condition	Conducted measurement at transmit chains

The Worst Case Mode for Following Conformance Tests			
Tests Item	Emissions in Restricted Frequency Bands		
Test Condition	Radiated measurement If EUT consist of multiple antenna assembly (multiple antenna are used in EUT regardless of spatial multiplexing MIMO configuration), the radiated test should be performed with highest antenna gain of each antenna type.		
Operating Mode < 1GHz	CTX		
1	Adapter mode		
Operating Mode > 1GHz	CTX		
Orthogonal Planes of EUT	X Plane	Y Plane	Z Plane
			
Worst Planes of EUT		V	

The Worst Case Mode for Following Conformance Tests	
Tests Item	Simultaneous Transmission Analysis
Test Condition	Radiated measurement
Operating Mode	CTX
1	WLAN 2.4GHz + WLAN 5GHz + WLAN 6GHz + Bluetooth
2	WLAN 2.4GHz + WLAN 5GHz + WLAN 6GHz + 802.15.4

Refer to Sporton Test Report No.: FA450601 for Co-location RF Exposure Evaluation and Appendix G for Radiated Emission Co-location.

2.3 Accessories

Accessories				
AC Adapter (US Plug)	Brand Name	Vantiva	Model Name	EPS72R0-16
	SN	DD72A2343A0551		
	Power Rating	I/P: 120Vac, 1.8A, O/P: 12Vdc, 6A		
	Power Cord	3.6 meter, non-shielded cable, w/o ferrite core		

Reminder: Regarding to more detail and other information, please refer to user manual.

2.4 Support Equipment

Support Equipment – Conducted					
No.	Equipment	Brand Name	Model Name	FCC ID	Remark
1	Notebook	DELL	E5410	-	-
2	Adapter for NB	DELL	HA65NM130	-	-

Support Equipment – Radiated					
No.	Equipment	Brand Name	Model Name	FCC ID	Remark
1	RJ45 cable	Power sync	CAT-6E-10	-	-
2	NB	HP	HSTNN-142C	-	Remote
3	Adapter for NB	HP	HSTNN-CA40	-	Remote
4	Client	AT&T	BGW620-700	-	Remote Provided by Customer

2.5 Test Setup Diagram

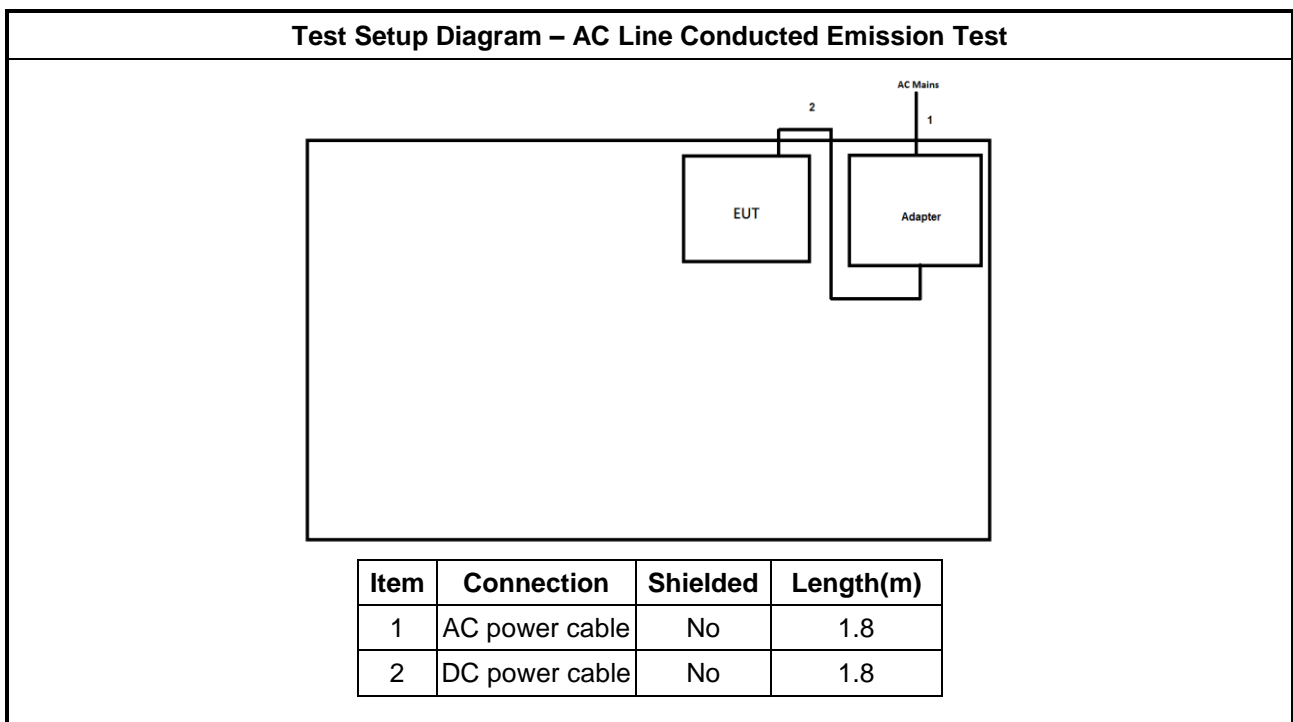

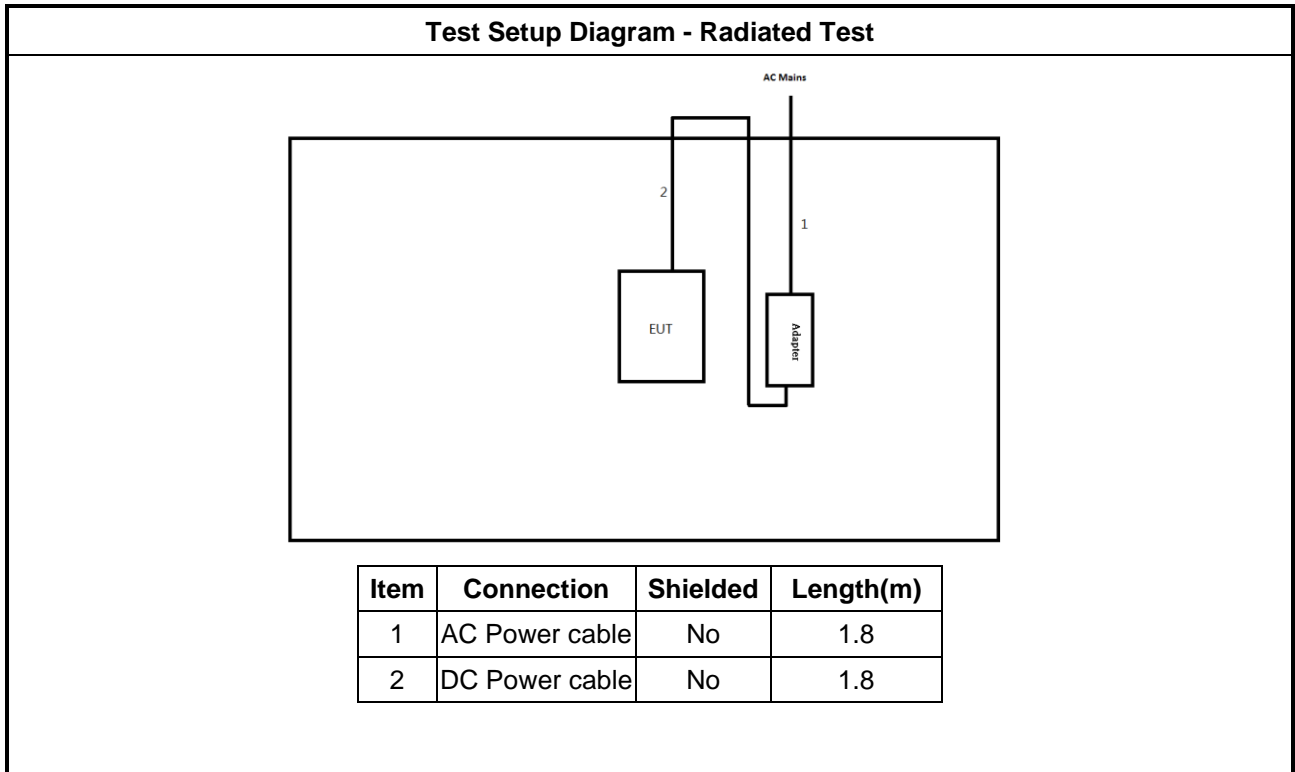

3 Transmitter Test Result

3.1 AC Power-line Conducted Emissions

3.1.1 AC Power-line Conducted Emissions Limit

AC Power-line Conducted Emissions Limit		
Frequency Emission (MHz)	Quasi-Peak	Average
0.15-0.5	66 - 56 *	56 - 46 *
0.5-5	56	46
5-30	60	50

Note 1: * Decreases with the logarithm of the frequency.

3.1.2 Measuring Instruments

Refer a test equipment and calibration data table in this test report.

3.1.3 Test Procedures

Test Method
<ul style="list-style-type: none"> Refer as ANSI C63.10-2013, clause 6.2 foray power-line conducted emissions.

3.1.4 Measurement Results Calculation

The measured Level is calculated using:

Corrected Reading: Raw(Read Level) + LISN(LISN Factor) + CL(Cable Loss) + AT(Attenuator).

3.1.5 Test Setup

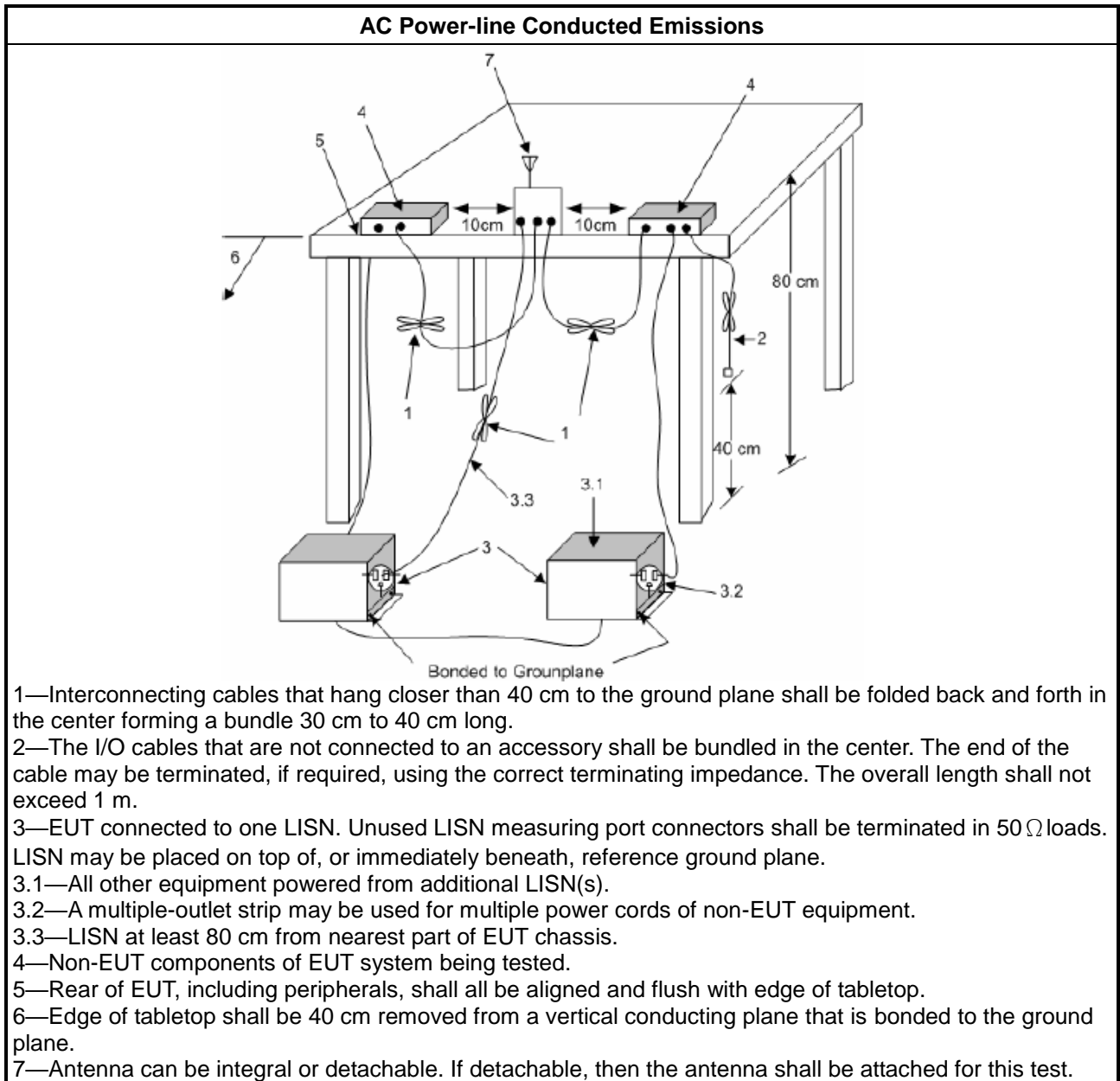

3.1.6 Test Result of AC Power-line Conducted Emissions

Refer as Appendix A

3.2 DTS Bandwidth

3.2.1 6dB Bandwidth Limit

6dB Bandwidth Limit	
Systems using digital modulation techniques:	
▪	6 dB bandwidth \geq 500 kHz.

3.2.2 Measuring Instruments

Refer a test equipment and calibration data table in this test report.

3.2.3 Test Procedures

Test Method	
▪	For the emission bandwidth shall be measured using one of the options below:
<input checked="" type="checkbox"/>	Refer as KDB 558074, clause 8.2 (11.8 of ANSI C63.10) DTS bandwidth measurement.
<input type="checkbox"/>	Refer as RSS-Gen, clause 6.7 for occupied bandwidth testing.
<input type="checkbox"/>	Refer as ANSI C63.10, clause 6.9.3 for occupied bandwidth testing.

3.2.4 Test Setup

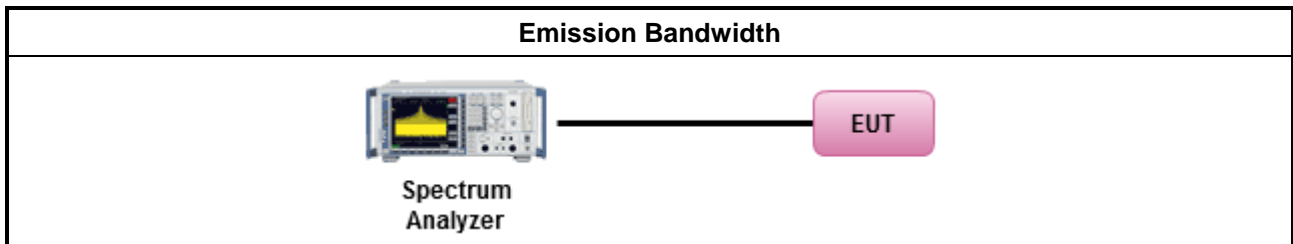

3.2.5 Test Result of Emission Bandwidth

Refer as Appendix B

3.3 Maximum Conducted Output Power

3.3.1 Maximum Conducted Output Power Limit

Maximum Conducted Output Power Limit	
	<ul style="list-style-type: none"> ▪ If $G_{TX} \leq 6$ dBi, then $P_{Out} \leq 30$ dBm (1 W)
	<ul style="list-style-type: none"> ▪ Point-to-multipoint systems (P2M): If $G_{TX} > 6$ dBi, then $P_{Out} = 30 - (G_{TX} - 6)$ dBm
	<ul style="list-style-type: none"> ▪ Point-to-point systems (P2P): If $G_{TX} > 6$ dBi, then $P_{Out} = 30 - (G_{TX} - 6)/3$ dBm
	<ul style="list-style-type: none"> ▪ Smart antenna system (SAS):
	<ul style="list-style-type: none"> - Single beam: If $G_{TX} > 6$ dBi, then $P_{Out} = 30 - (G_{TX} - 6)/3$ dBm
	<ul style="list-style-type: none"> - Overlap beam: If $G_{TX} > 6$ dBi, then $P_{Out} = 30 - (G_{TX} - 6)/3$ dBm
	<ul style="list-style-type: none"> - Aggregate power on all beams: If $G_{TX} > 6$ dBi, then $P_{Out} = 30 - (G_{TX} - 6)/3 + 8$ dB dBm
e.i.r.p. Power Limit:	
	<ul style="list-style-type: none"> ▪ 2400-2483.5 MHz Band
	<ul style="list-style-type: none"> ▪ Point-to-multipoint systems (P2M): $P_{eirp} \leq 36$ dBm (4 W)
	<ul style="list-style-type: none"> ▪ Point-to-point systems (P2P): $P_{eirp} \leq \text{MAX}(36, [P_{Out} + G_{TX}])$ dBm
	<ul style="list-style-type: none"> ▪ Smart antenna system (SAS)
	<ul style="list-style-type: none"> - Single beam: $P_{eirp} \leq \text{MAX}(36, P_{Out} + G_{TX})$ dBm
	<ul style="list-style-type: none"> - Overlap beam: $P_{eirp} \leq \text{MAX}(36, P_{Out} + G_{TX})$ dBm
	<ul style="list-style-type: none"> - Aggregate power on all beams: $P_{eirp} \leq \text{MAX}(36, [P_{Out} + G_{TX} + 8])$ dBm
<p>P_{Out} = maximum peak conducted output power or maximum conducted output power in dBm, G_{TX} = the maximum transmitting antenna directional gain in dBi.</p>	

3.3.2 Measuring Instruments

Refer a test equipment and calibration data table in this test report.

3.3.3 Test Procedures

Test Method	
<ul style="list-style-type: none"> ▪ Maximum Peak Conducted Output Power 	
<input type="checkbox"/>	Refer as KDB 558074, clause 8.3.1.1 (11.9.1.1 of ANSI C63.10) RBW ≥ EBW method.
<input type="checkbox"/>	Refer as KDB 558074, clause 8.3.1.2 (11.9.1.2 of ANSI C63.10) integrated band power method.
<input type="checkbox"/>	Refer as KDB 558074, clause 8.3.1.3 (11.9.1.3 of ANSI C63.10) peak power meter.
<ul style="list-style-type: none"> ▪ Maximum Average Conducted Output Power 	
<input type="checkbox"/>	Refer as KDB 558074, clause 8.3.2.2 (11.9.2.2 of ANSI C63.10) using a spectrum analyzer.
<input checked="" type="checkbox"/>	Refer as KDB 558074, clause 8.3.2.3 (11.9.2.3 of ANSI C63.10) using a power meter.
<ul style="list-style-type: none"> ▪ For conducted measurement. 	
<ul style="list-style-type: none"> ▪ If the EUT supports multiple transmit chains using options given below: Refer as KDB 662911, In-band power measurements. Using the measure-and-sum approach, measured all transmit ports individually. Sum the power (in linear power units e.g., mW) of all ports for each individual sample and save them. 	
<ul style="list-style-type: none"> ▪ If multiple transmit chains, EIRP calculation could be following as methods: $P_{total} = P_1 + P_2 + \dots + P_n$ (calculated in linear unit [mW] and transfer to log unit [dBm]) $EIRP_{total} = P_{total} + DG$ 	

3.3.4 Test Setup

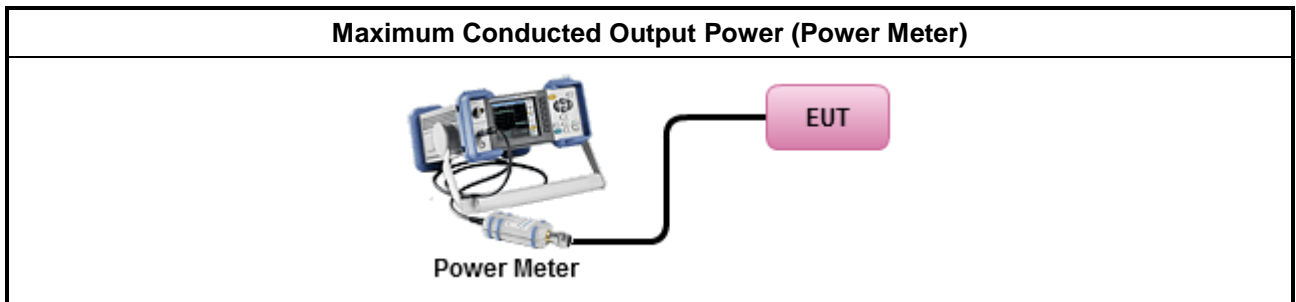

3.3.5 Test Result of Maximum Conducted Output Power

Refer as Appendix C

3.4 Power Spectral Density

3.4.1 Power Spectral Density Limit

Power Spectral Density Limit
<ul style="list-style-type: none"> Power Spectral Density (PSD) ≤ 8 dBm/3kHz

3.4.2 Measuring Instruments

Refer a test equipment and calibration data table in this test report.

3.4.3 Test Procedures

Test Method	
<ul style="list-style-type: none"> Peak power spectral density procedures that the same method as used to determine the conducted output power. If maximum peak conducted output power was measured to demonstrate compliance to the output power limit, then the peak PSD procedure below (Method PKPSD) shall be used. If maximum conducted output power was measured to demonstrate compliance to the output power limit, then one of the average PSD procedures shall be used, as applicable based on the following criteria (the peak PSD procedure is also an acceptable option). 	
<input checked="" type="checkbox"/>	Refer as KDB 558074, clause 8.4 (11.10 of ANSI C63.10) Max. PSD.
<ul style="list-style-type: none"> For conducted measurement. <ul style="list-style-type: none"> If The EUT supports multiple transmit chains using options given below: <ul style="list-style-type: none"> Measure and sum the spectra across the outputs. Refer as KDB 662911, In-band power spectral density (PSD). Sample all transmit ports simultaneously using a spectrum analyzer for each transmit port. Where the trace bin-by-bin of each transmit port summing can be performed. (i.e., in the first spectral bin of output 1 is summed with that in the first spectral bin of output 2 and that from the first spectral bin of output 3, and so on up to the NTX output to obtain the value for the first frequency bin of the summed spectrum.). Add up the amplitude (power) values for the different transmit chains and use this as the new data trace. 	

3.4.4 Test Setup

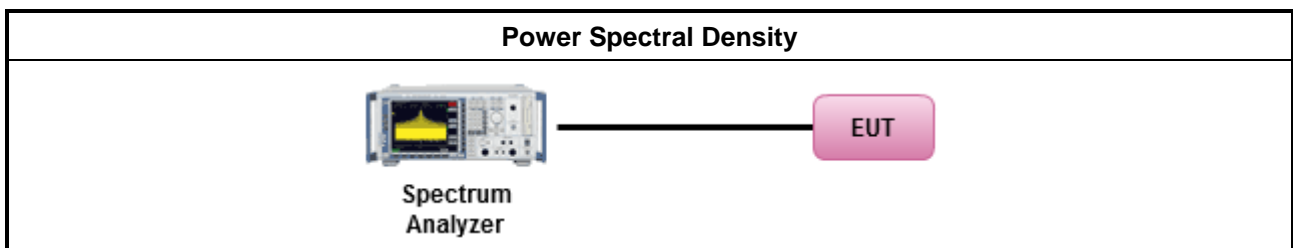

3.4.5 Test Result of Power Spectral Density

Refer as Appendix D

3.5 Emissions in Non-restricted Frequency Bands

3.5.1 Emissions in Non-restricted Frequency Bands Limit

Un-restricted Band Emissions Limit	
RF output power procedure	Limit (dB)
Peak output power procedure	20
Average output power procedure	30

Note 1: If the peak output power procedure is used to measure the fundamental emission power to demonstrate compliance to requirements, then the peak conducted output power measured within any 100 kHz outside the authorized frequency band shall be attenuated by at least 20 dB relative to the maximum measured in-band peak level.

Note 2: If the average output power procedure is used to measure the fundamental emission power to demonstrate compliance to requirements, then the power in any 100 kHz outside of the authorized frequency band shall be attenuated by at least 30 dB relative to the maximum measured in-band average level.

3.5.2 Measuring Instruments

Refer a test equipment and calibration data table in this test report.

3.5.3 Test Procedures

Test Method
<ul style="list-style-type: none"> Refer as KDB 558074, clause 8.5 (11.11 of ANSI C63.10) for non-restricted frequency bands.

3.5.4 Test Setup

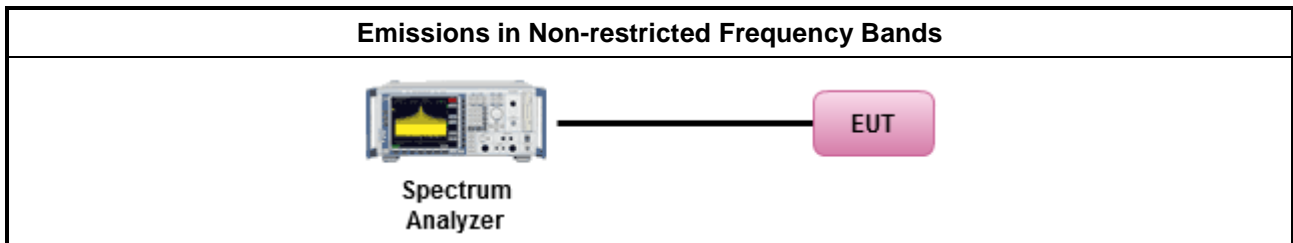

3.5.5 Test Result of Emissions in Non-restricted Frequency Bands

Refer as Appendix E

3.6 Emissions in Restricted Frequency Bands

3.6.1 Emissions in Restricted Frequency Bands Limit

Restricted Band Emissions Limit			
Frequency Range (MHz)	Field Strength (uV/m)	Field Strength (dBuV/m)	Measure Distance (m)
0.009~0.490	2400/F(kHz)	48.5 - 13.8	300
0.490~1.705	24000/F(kHz)	33.8 - 23	30
1.705~30.0	30	29	30
30~88	100	40	3
88~216	150	43.5	3
216~960	200	46	3
Above 960	500	54	3

Note 1: Test distance for frequencies at or above 30 MHz, measurements may be performed at a distance other than the limit distance provided they are not performed in the near field and the emissions to be measured can be detected by the measurement equipment. When performing measurements at a distance other than that specified, the results shall be extrapolated to the specified distance using an extrapolation factor of 20 dB/decade (inverse of linear distance for field-strength measurements, inverse of linear distance-squared for power-density measurements).

Note 2: Test distance for frequencies at below 30 MHz, measurements may be performed at a distance closer than the EUT limit distance; however, an attempt should be made to avoid making measurements in the near field. When performing measurements below 30 MHz at a closer distance than the limit distance, the results shall be extrapolated to the specified distance by either making measurements at a minimum of two or more distances on at least one radial to determine the proper extrapolation factor or by using the square of an inverse linear distance extrapolation factor (40 dB / decade). The test report shall specify the extrapolation method used to determine compliance of the EUT.

Note 3: Using the distance of 1m during the test for above 18 GHz, and the test value to correct for the distance factor at 3m.

3.6.2 Measuring Instruments

Refer a test equipment and calibration data table in this test report.

3.6.3 Test Procedures

Test Method	
	<ul style="list-style-type: none"> ▪ The average emission levels shall be measured in [duty cycle ≥ 98 or duty factor].
	<ul style="list-style-type: none"> ▪ Refer as ANSI C63.10, clause 6.10.3 band-edge testing shall be performed at the lowest frequency channel and highest frequency channel within the allowed operating band.
	<ul style="list-style-type: none"> ▪ For the transmitter unwanted emissions shall be measured using following options below:
	<ul style="list-style-type: none"> ▪ Refer as KDB 558074, clause 8.6 (11.12 of ANSI C63.10) for restricted frequency bands.
	<ul style="list-style-type: none"> ▪ For the transmitter band-edge emissions shall be measured using following options below:
	<ul style="list-style-type: none"> ▪ Refer as KDB 558074 clause 8.7.1, When the performing peak or average radiated measurements, emissions within 2 MHz of the authorized band edge may be measured using the marker-delta method described below.
	<ul style="list-style-type: none"> ▪ Refer as KDB 558074, clause 8.7.2 (6.10.6 of ANSI C63.10) for marker-delta method for band-edge measurements.
	<ul style="list-style-type: none"> ▪ Refer as KDB 558074, clause 8.7.3 for narrower resolution bandwidth (100kHz) using the band power and summing the spectral levels.
	<ul style="list-style-type: none"> ▪ Use the following spectrum analyzer settings:
	<ul style="list-style-type: none"> ▪ Set RBW=100 kHz for f < 1 GHz; VBW=3 * RBW; Sweep = auto; Detector function = peak; Trace = max hold.
	<ul style="list-style-type: none"> ▪ Set RBW = 1 MHz, VBW= 3MHz for f ≥ 1 GHz for peak measurement. For average measurement, refer as 1.1.4.
	<ul style="list-style-type: none"> ▪ KDB 414788 Open-Field Test Sites and Chamber Correlation Justification.
	<ul style="list-style-type: none"> ▪ Based on FCC 15.31(f)(2): measurements may be performed at a distance closer than that specified in regulations; however, an attempt should be made to avoid making measurements in the near field.
	<ul style="list-style-type: none"> ▪ Open-field site and chamber correlation testing had been performed and chamber measured test result is the worst case test result.

3.6.4 Measurement Results Calculation

The measured Level is calculated using:

Corrected Reading: Raw(Read Level) + AF(Antenna Factor) + CL(Cable Loss) - PA(Preamp Factor)

3.6.5 Test Setup

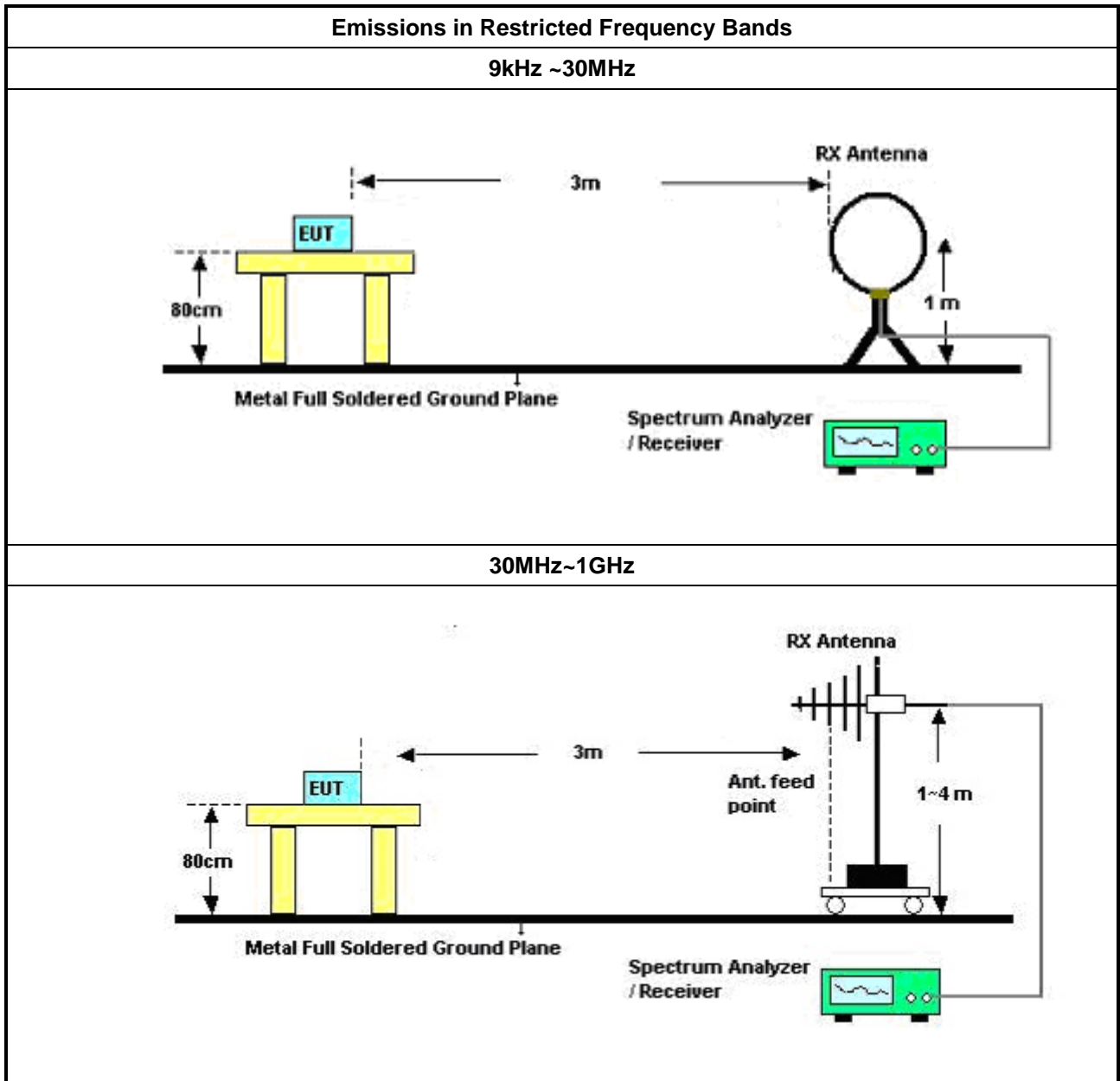

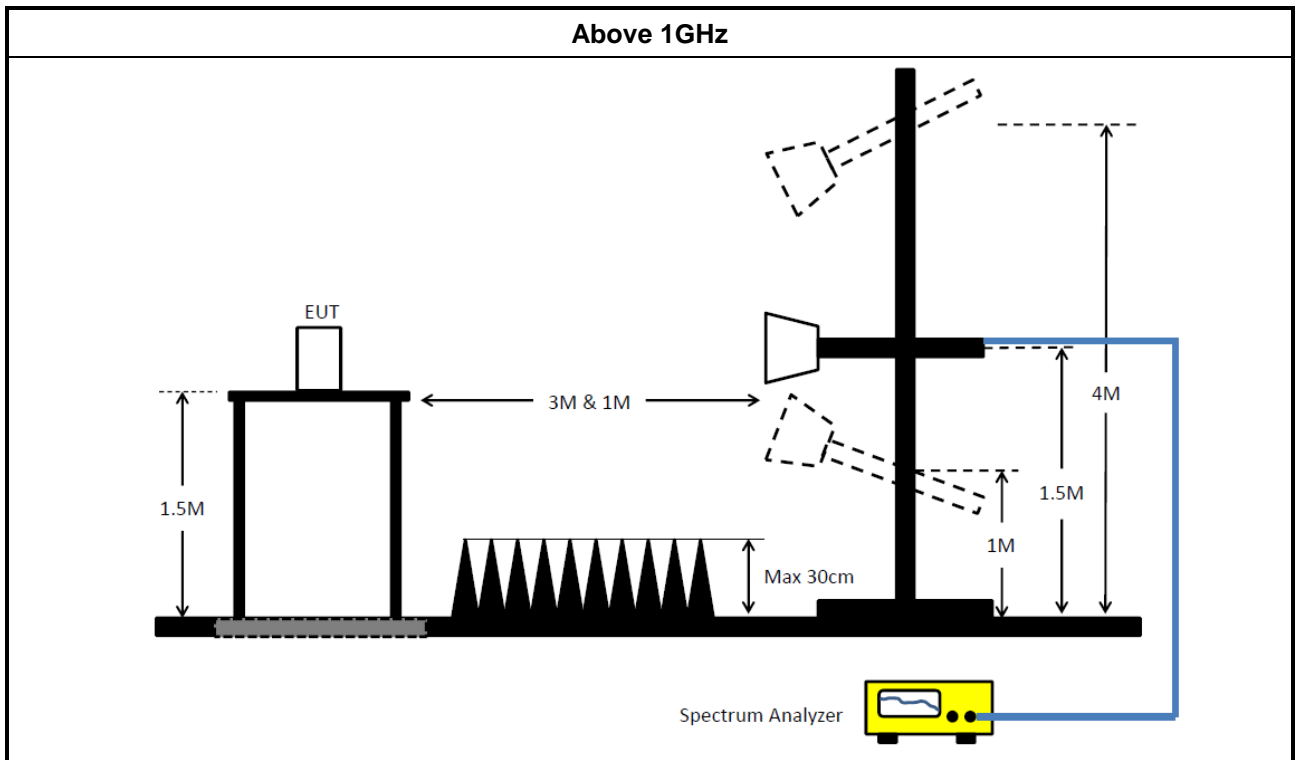

3.6.6 Test Result of Emissions in Restricted Frequency Bands (Below 30MHz)

The amplitude of spurious emissions which are attenuated by more than 20dB below the permissible value has no need to be reported.

3.6.7 Test Result of Emissions in Restricted Frequency Bands

Refer as Appendix F



4 Test Equipment and Calibration Data

Instrument for AC Conduction

Instrument	Manufacturer /Brand	Model No.	Serial No.	Spec.	Calibration Date	Calibration Due Date
EMI Test Receiver	ROHDE & SCHWARZ	ESR3	102051	9kHz ~ 3.6GHz	17/May/2024	16/May/2025
LISN(Artificial Mains Network)	SCHWARZBECK	NSLK 8127	8127477	9kHz ~ 30MHz	12/Apr/2024	11/Apr/2025
RF Cable 5m	TITAN	TITAN	CO04-cable-01	9 kHz~200MHz	27/Feb/2024	26/Feb/2025
Impuls Begrenzer Pulse Limiter	SCHWARZBECK	VTSD 9561-F	9561-F041	9kHz ~ 30MHz	18/Oct/2023	17/Oct/2024
Software	Sporton	SENSE-EMI	V5.11.3	-	NCR	NCR

NCR: No Calibration Required

Instrument for Conducted Test

Instrument	Manufacturer /Brand	Model No.	Serial No.	Spec.	Calibration Date	Calibration Due Date
Signal Analyzer	R&S	FSV 40	101515	9kHz~40GHz	02/Feb/2024	01/Feb/2025
SMB100A Signal Generator	R&S	SMB100A	181147	100kHz~40GHz	20/Oct/2023	19/Oct/2024
Power Meter	Anritsu	ML2495A	1517010	300MHz~40GHz	15/Dec/2023	14/Dec/2024
Pulse Sensor	Anritsu	MA2411B	1339407	300MHz~40GHz	15/Dec/2023	14/Dec/2024
SENSE-15247_FS	Sporton	V5.11.18	N/A	N/A	N/A	N/A



Instrument for Radiated Test

Instrument	Manufacturer /Brand	Model No.	Serial No.	Spec.	Calibration Date	Calibration Due Date
3m Semi Anechoic Chamber	TDK	SAC-3M	03CH25-HY	30MHz~1GHz 3m	03/Aug/2023	02/Aug/2024
3m Semi Anechoic Chamber	TDK	SAC-3M	03CH25-HY	1GHz~18GHz 3m	09/Aug/2023	08/Aug/2024
EMI Test Receiver	ROHDE & SCHWARZ	ESR	102318	9kHz~3.6GHz	27/Dec/2023	26/Dec/2024
Signal Analyzer	ROHDE&SCHWARZ	FSV3044	101410	10Hz~44GHz	17/Nov/2023	16/Nov/2024
Loop Antenna	TESEQ	HLA 6120	31244	9kHz~30MHz	19/Mar/2024	18/Mar/2025
Bilog Antenna & 6dB Attenuator	TESEQ & VGT	CBL 6111D & VFA 04002-06	63537/001	30MHz~1GHz	31/May/2023	30/May/2024
Bilog Antenna & 6dB Attenuator	TESEQ & VGT	CBL 6111D & VFA 04002-06	63537/001	30MHz~1GHz	30/May/2024	29/May/2025
Double Ridged Guide Horn Antenna	SCHWARZBECK	BBHA 9120 D	02876	1GHz~18GHz	12/Jul/2023	11/Jul/2024
Double Ridged Guide Horn Antenna	SCHWARZBECK	BBHA 9120 D	02876	1GHz~18GHz	11/Jul/2023	10/Jul/2025
Broadband Horn Antenna	SCHWARZBECK	BBHA 9170	01248	18GHz~40GHz	21/Aug/2023	20/Aug/2024
RF Cable	HUBER+SUHNER	SUOFLEX 104	CB007	9kHz~1GHz	24/Apr/2024	23/Apr/2025
RF Cable	HUBER+SUHNER	SUOFLEX 104	CB007	1GHz~40GHz	23/Apr/2024	22/Apr/2025
Preamplifier	SGH	PRAMP 903	20230515-1	25MHz~3GHz	25/May/2023	24/May/2024
Preamplifier	SGH	PRAMP 903	20230515-1	25MHz~3GHz	24/May/2023	23/May/2025
Preamplifier	SGH	PRAMP 118-H	20230515-3	1GHz ~18GHz	25/May/2023	24/May/2024
Preamplifier	SGH	PRAMP 118-H	20230515-3	1GHz ~18GHz	24/May/2023	23/May/2025
Amplifier	EM	EM18G40GA	060874	18GHz ~ 40GHz	15/Apr/2024	14/Apr/2025
SENSE-15247-FS	Sporton	V5.11.18	NA	NA	NA	NA



Summary

Mode	Result	Type	Freq (Hz)	Level (dBuV)	Limit (dBuV)	Margin (dB)	Condition
Mode 1	Pass	QP	386.35k	39.87	58.14	-18.27	Neutral



Result

Mode	Result	Type	Freq (Hz)	Level (dBuV)	Limit (dBuV)	Margin (dB)	Condition	Comments
Mode 1	Pass	QP	155.487k	36.34	65.69	-29.35	Line	-
Mode 1	Pass	AV	155.487k	24.84	55.69	-30.85	Line	-
Mode 1	Pass	QP	230.851k	27.33	62.42	-35.09	Line	-
Mode 1	Pass	AV	230.851k	20.85	52.42	-31.57	Line	-
Mode 1	Pass	QP	403.694k	36.71	57.78	-21.07	Line	-
Mode 1	Pass	AV	403.694k	26.73	47.78	-21.05	Line	-
Mode 1	Pass	QP	633.814k	23.43	56.00	-32.57	Line	-
Mode 1	Pass	AV	633.814k	16.42	46.00	-29.58	Line	-
Mode 1	Pass	QP	5.472M	24.54	60.00	-35.46	Line	-
Mode 1	Pass	AV	5.472M	18.69	50.00	-31.31	Line	-
Mode 1	Pass	QP	10.532M	27.80	60.00	-32.20	Line	-
Mode 1	Pass	AV	10.532M	22.95	50.00	-27.05	Line	-
Mode 1	Pass	QP	157.361k	35.04	65.60	-30.56	Neutral	-
Mode 1	Pass	AV	157.361k	26.33	55.60	-29.27	Neutral	-
Mode 1	Pass	QP	246.077k	27.32	61.89	-34.57	Neutral	-
Mode 1	Pass	AV	246.077k	21.55	51.89	-30.34	Neutral	-
Mode 1	Pass	QP	386.35k	39.87	58.14	-18.27	Neutral	-
Mode 1	Pass	AV	386.35k	28.60	48.14	-19.54	Neutral	-
Mode 1	Pass	QP	889.871k	19.16	56.00	-36.84	Neutral	-
Mode 1	Pass	AV	889.871k	12.06	46.00	-33.94	Neutral	-
Mode 1	Pass	QP	5.429M	22.58	60.00	-37.42	Neutral	-
Mode 1	Pass	AV	5.429M	17.07	50.00	-32.93	Neutral	-
Mode 1	Pass	QP	11.048M	25.86	60.00	-34.14	Neutral	-
Mode 1	Pass	AV	11.048M	20.50	50.00	-29.50	Neutral	-

Conducted Emissions at Powerline_Mode 1

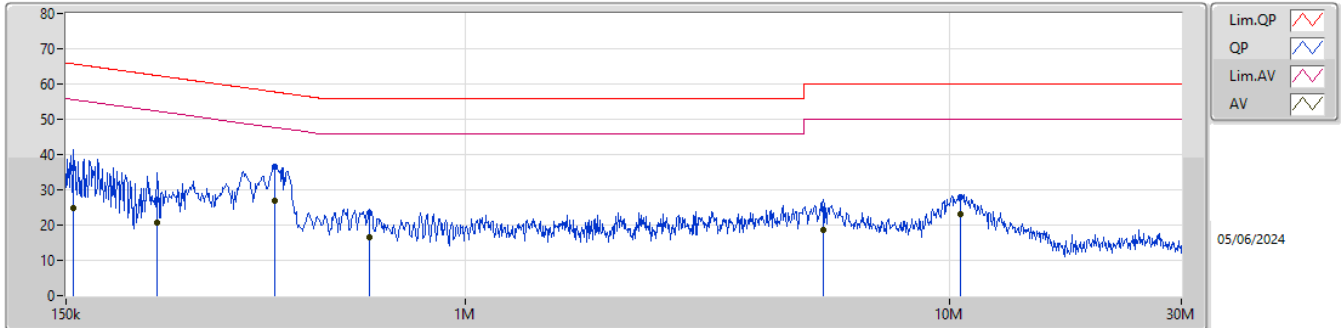

Type	Freq (Hz)	Level (dBuV)	Limit (dBuV)	Margin (dB)	Factor (dB)	Condition	Comment	Raw (dBuV)	LISN (dB)	CL (dB)	AT (dB)
QP	155.487k	36.34	65.69	-29.35	9.86	Line	-	26.48	0.04	0.07	9.75
AV	155.487k	24.84	55.69	-30.85	9.86	Line	-	14.98	0.04	0.07	9.75
QP	230.851k	27.33	62.42	-35.09	9.84	Line	-	17.49	0.04	0.10	9.70
AV	230.851k	20.85	52.42	-31.57	9.84	Line	-	11.01	0.04	0.10	9.70
QP	403.694k	36.71	57.78	-21.07	9.93	Line	-	26.78	0.05	0.12	9.76
AV	403.694k	26.73	47.78	-21.05	9.93	Line	-	16.80	0.05	0.12	9.76
QP	633.814k	23.43	56.00	-32.57	9.94	Line	-	13.49	0.06	0.10	9.78
AV	633.814k	16.42	46.00	-29.58	9.94	Line	-	6.48	0.06	0.10	9.78
QP	5.472M	24.54	60.00	-35.46	9.99	Line	-	14.55	0.14	0.06	9.79
AV	5.472M	18.69	50.00	-31.31	9.99	Line	-	8.70	0.14	0.06	9.79
QP	10.532M	27.80	60.00	-32.20	10.08	Line	-	17.72	0.22	0.06	9.80
AV	10.532M	22.95	50.00	-27.05	10.08	Line	-	12.87	0.22	0.06	9.80

Conducted Emissions at Powerline_Mode 1

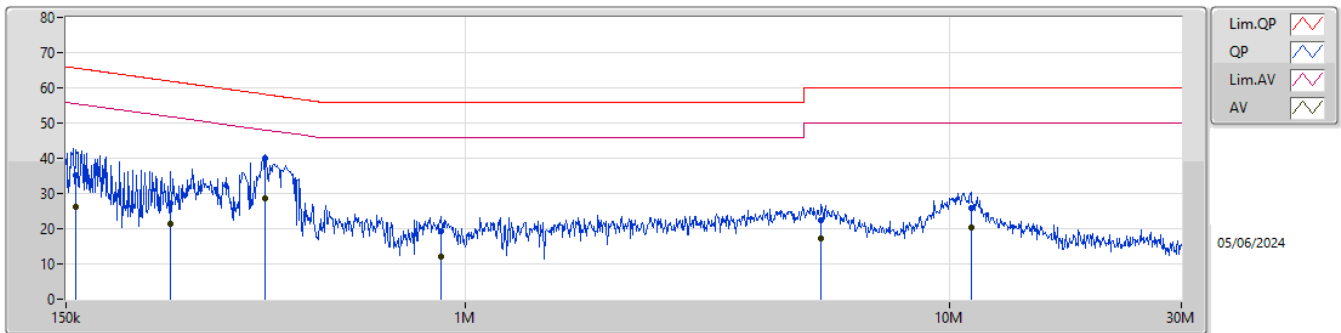

Type	Freq (Hz)	Level (dBuV)	Limit (dBuV)	Margin (dB)	Factor (dB)	Condition	Comment	Raw (dBuV)	LISN (dB)	CL (dB)	AT (dB)
QP	157.361k	35.04	65.60	-30.56	9.88	Neutral	-	25.16	0.06	0.07	9.75
AV	157.361k	26.33	55.60	-29.27	9.88	Neutral	-	16.45	0.06	0.07	9.75
QP	246.077k	27.32	61.89	-34.57	9.86	Neutral	-	17.46	0.06	0.10	9.70
AV	246.077k	21.55	51.89	-30.34	9.86	Neutral	-	11.69	0.06	0.10	9.70
QP	386.35k	39.87	58.14	-18.27	9.95	Neutral	-	29.92	0.07	0.12	9.76
AV	386.35k	28.60	48.14	-19.54	9.95	Neutral	-	18.65	0.07	0.12	9.76
QP	889.871k	19.16	56.00	-36.84	9.96	Neutral	-	9.20	0.08	0.09	9.79
AV	889.871k	12.06	46.00	-33.94	9.96	Neutral	-	2.10	0.08	0.09	9.79
QP	5.429M	22.58	60.00	-37.42	10.02	Neutral	-	12.56	0.17	0.06	9.79
AV	5.429M	17.07	50.00	-32.93	10.02	Neutral	-	7.05	0.17	0.06	9.79
QP	11.048M	25.86	60.00	-34.14	10.14	Neutral	-	15.72	0.28	0.06	9.80
AV	11.048M	20.50	50.00	-29.50	10.14	Neutral	-	10.36	0.28	0.06	9.80



Summary

Mode	Max-N dB (Hz)	Max-OBW (Hz)	ITU-Code	Min-N dB (Hz)	Min-OBW (Hz)
2.4-2.4835GHz	-	-	-	-	-
BT-LE(1Mbps)	705k	1.048M	1M05F1D	528.75k	1.034M
BT-LE(125kbps)	702.5k	1.077M	1M08F1D	653.75k	1.063M
BT-LE(500kbps)	710k	1.054M	1M05F1D	638.75k	1.037M
BT-LE(2Mbps)	1.375M	2.081M	2M08F1D	945k	2.061M

Max-N dB = Maximum 6dB down bandwidth; Max-OBW = Maximum 99% occupied bandwidth;
Min-N dB = Minimum 6dB down bandwidth; Min-OBW = Minimum 99% occupied bandwidth

Result

Mode	Result	Limit (Hz)	Port 1-N dB (Hz)	Port 1-OBW (Hz)
BT-LE(1Mbps)	-	-	-	-
2402MHz	Pass	500k	705k	1.043M
2440MHz	Pass	500k	626.25k	1.048M
2480MHz	Pass	500k	528.75k	1.034M
BT-LE(2Mbps)	-	-	-	-
2402MHz	Pass	500k	1.375M	2.061M
2440MHz	Pass	500k	1.058M	2.079M
2478MHz	Pass	500k	945k	2.081M
2480MHz	Pass	500k	1.205M	2.064M
BT-LE(125kbps)	-	-	-	-
2402MHz	Pass	500k	653.75k	1.077M
2440MHz	Pass	500k	702.5k	1.063M
2480MHz	Pass	500k	700k	1.068M
BT-LE(500kbps)	-	-	-	-
2402MHz	Pass	500k	710k	1.037M
2440MHz	Pass	500k	703.75k	1.05M
2480MHz	Pass	500k	638.75k	1.054M

Port X-N dB = Port X 6dB down bandwidth;
 Port X-OBW = Port X 99% occupied bandwidth

2.4-2.4835GHz_BT-LE(1Mbps)

EBW-DTS

2402MHz

15/05/2024

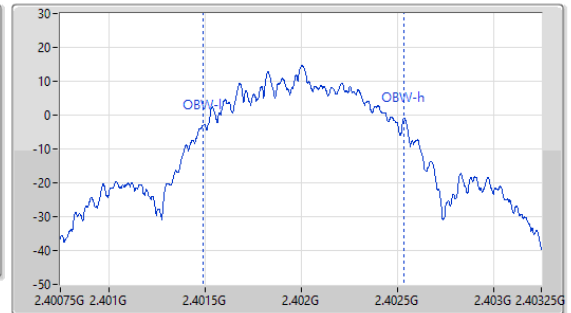
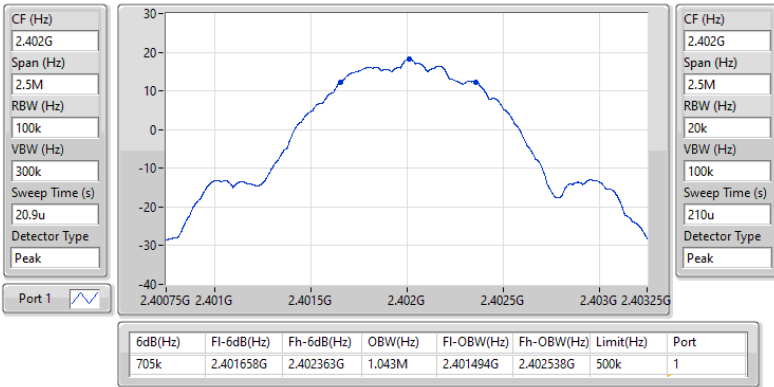

2.4-2.4835GHz_BT-LE(125kbps)

EBW-DTS

2440MHz

15/05/2024

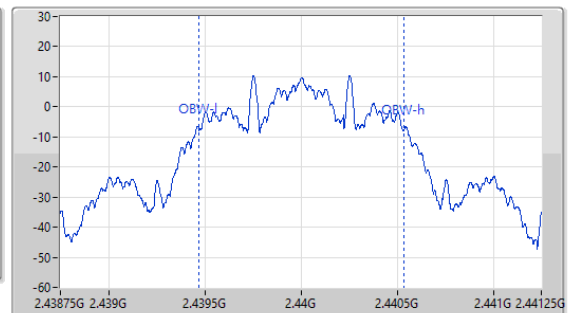
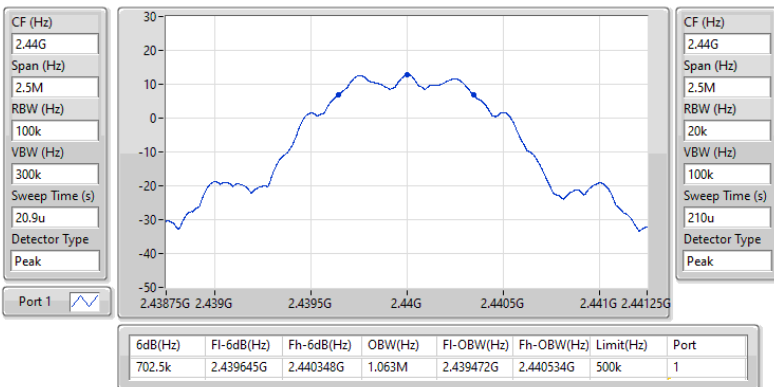

2.4-2.4835GHz_BT-LE(500kbps)

EBW-DTS

2402MHz

15/05/2024

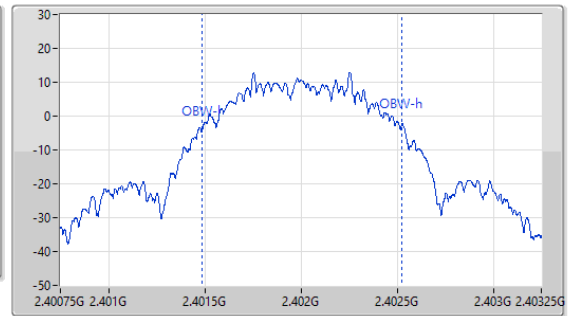
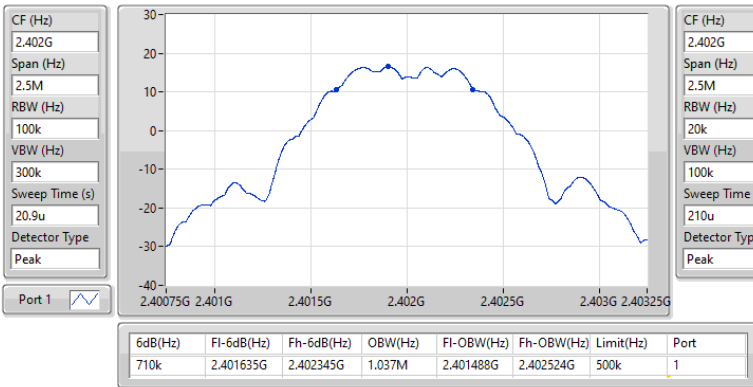

2.4-2.4835GHz_BT-LE(2Mbps)

EBW-DTS

2402MHz

15/05/2024

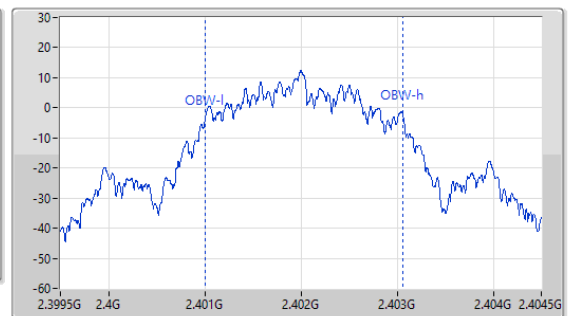
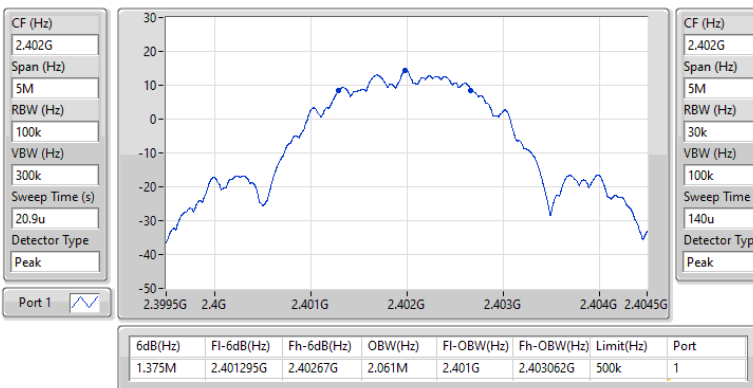



Summary

Mode	Total Power (dBm)	Total Power (W)
2.4-2.4835GHz	-	-
BT-LE(1Mbps)	18.74	0.07482
BT-LE(125kbps)	16.29	0.04256
BT-LE(500kbps)	18.99	0.07925
BT-LE(2Mbps)	18.55	0.07161



Result

Mode	Result	DG (dBi)	Total Power (dBm)	Power Limit (dBm)
BT-LE(1Mbps)	-	-	-	-
2402MHz	Pass	3.765	18.62	30.00
2440MHz	Pass	3.765	18.74	30.00
2480MHz	Pass	3.765	17.11	30.00
BT-LE(2Mbps)	-	-	-	-
2402MHz	Pass	3.765	18.38	30.00
2440MHz	Pass	3.765	18.55	30.00
2478MHz	Pass	3.765	16.91	30.00
2480MHz	Pass	3.765	13.75	30.00
BT-LE(125kbps)	-	-	-	-
2402MHz	Pass	3.765	16.21	30.00
2440MHz	Pass	3.765	16.29	30.00
2480MHz	Pass	3.765	15.60	30.00
BT-LE(500kbps)	-	-	-	-
2402MHz	Pass	3.765	18.87	30.00
2440MHz	Pass	3.765	18.99	30.00
2480MHz	Pass	3.765	17.33	30.00

DG = Directional Gain; Port X = Port X output power;
Inf = There's no restriction for the limit.



Summary

Mode	PD (dBm/RBW)
2.4-2.4835GHz	-
BT-LE(1Mbps)	3.71
BT-LE(125kbps)	7.95
BT-LE(500kbps)	4.17
BT-LE(2Mbps)	1.64

RBW = 3kHz;



Result

Mode	Result	DG (dBi)	PD (dBm/RBW)	PD Limit (dBm/RBW)
BT-LE(1Mbps)	-	-	-	-
2402MHz	Pass	3.765	3.65	8.00
2440MHz	Pass	3.765	3.71	8.00
2480MHz	Pass	3.765	1.82	8.00
BT-LE(2Mbps)	-	-	-	-
2402MHz	Pass	3.765	0.71	8.00
2440MHz	Pass	3.765	1.64	8.00
2478MHz	Pass	3.765	-0.22	8.00
2480MHz	Pass	3.765	-3.97	8.00
BT-LE(125kbps)	-	-	-	-
2402MHz	Pass	3.765	7.66	8.00
2440MHz	Pass	3.765	7.95	8.00
2480MHz	Pass	3.765	7.28	8.00
BT-LE(500kbps)	-	-	-	-
2402MHz	Pass	3.765	4.17	8.00
2440MHz	Pass	3.765	4.07	8.00
2480MHz	Pass	3.765	3.10	8.00

DG = Directional Gain; RBW = 3kHz;
PD = trace bin-by-bin of each transmits port summing can be performed maximum power density; Port X = Port X Power Density;
Inf = There's no restriction for the limit.

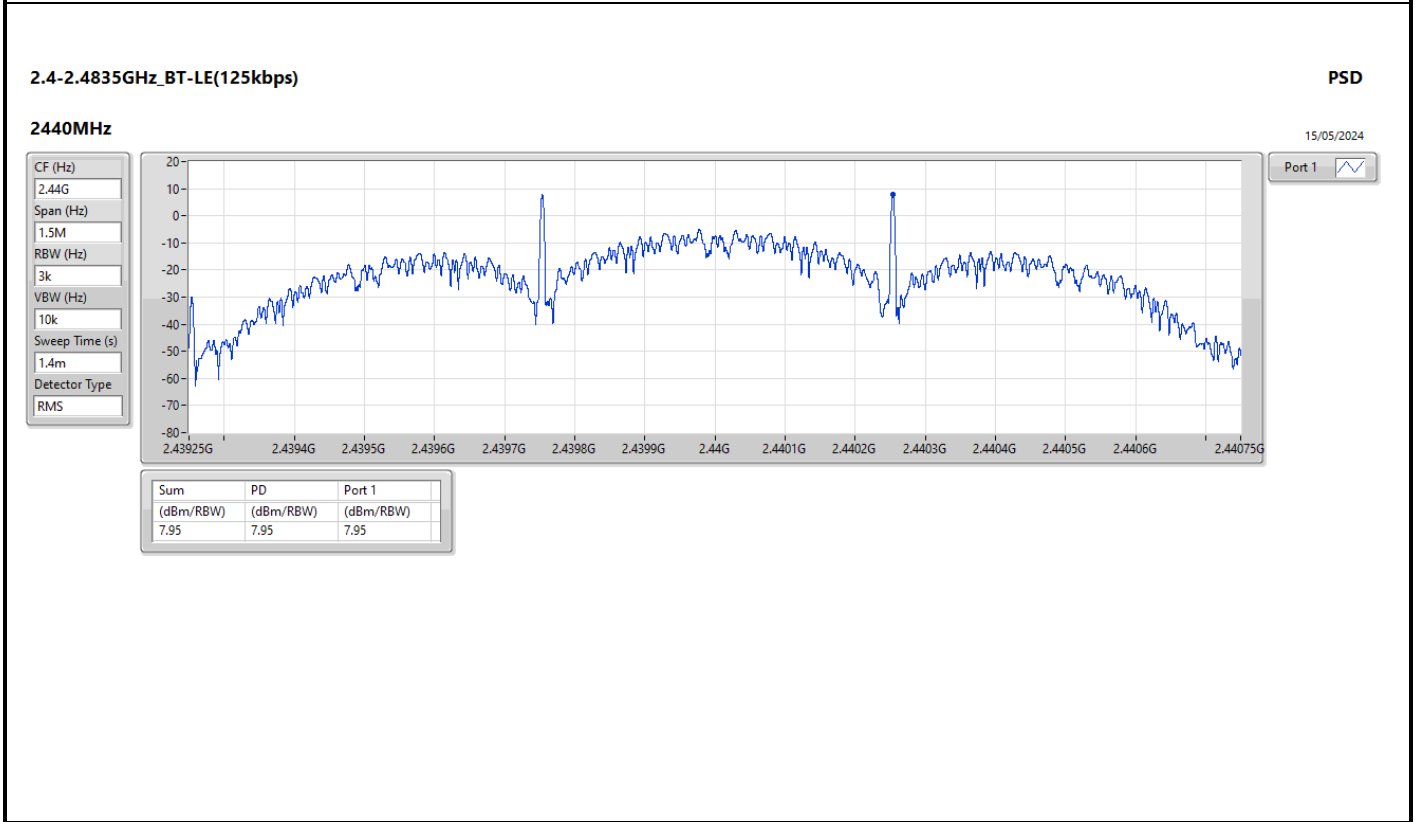
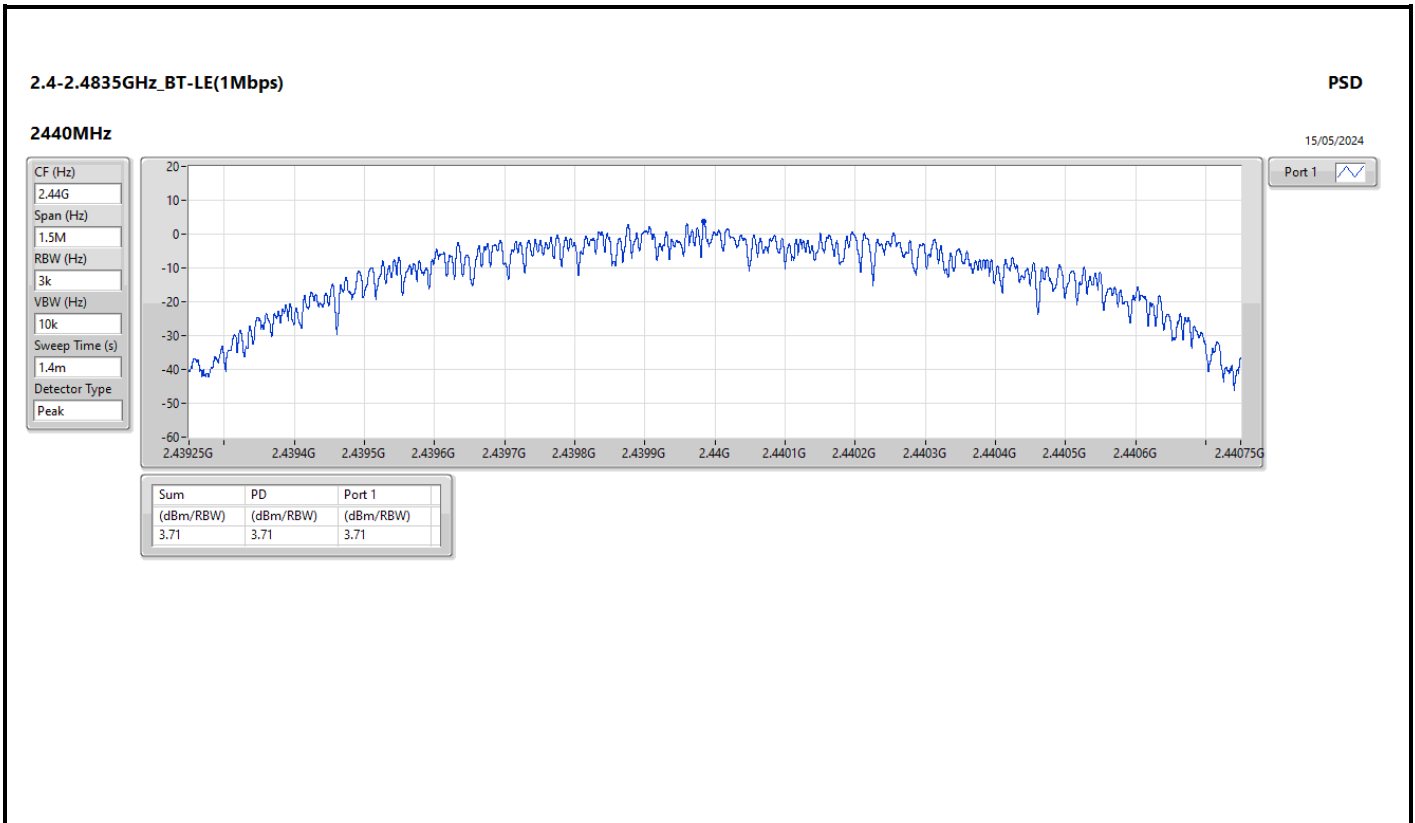

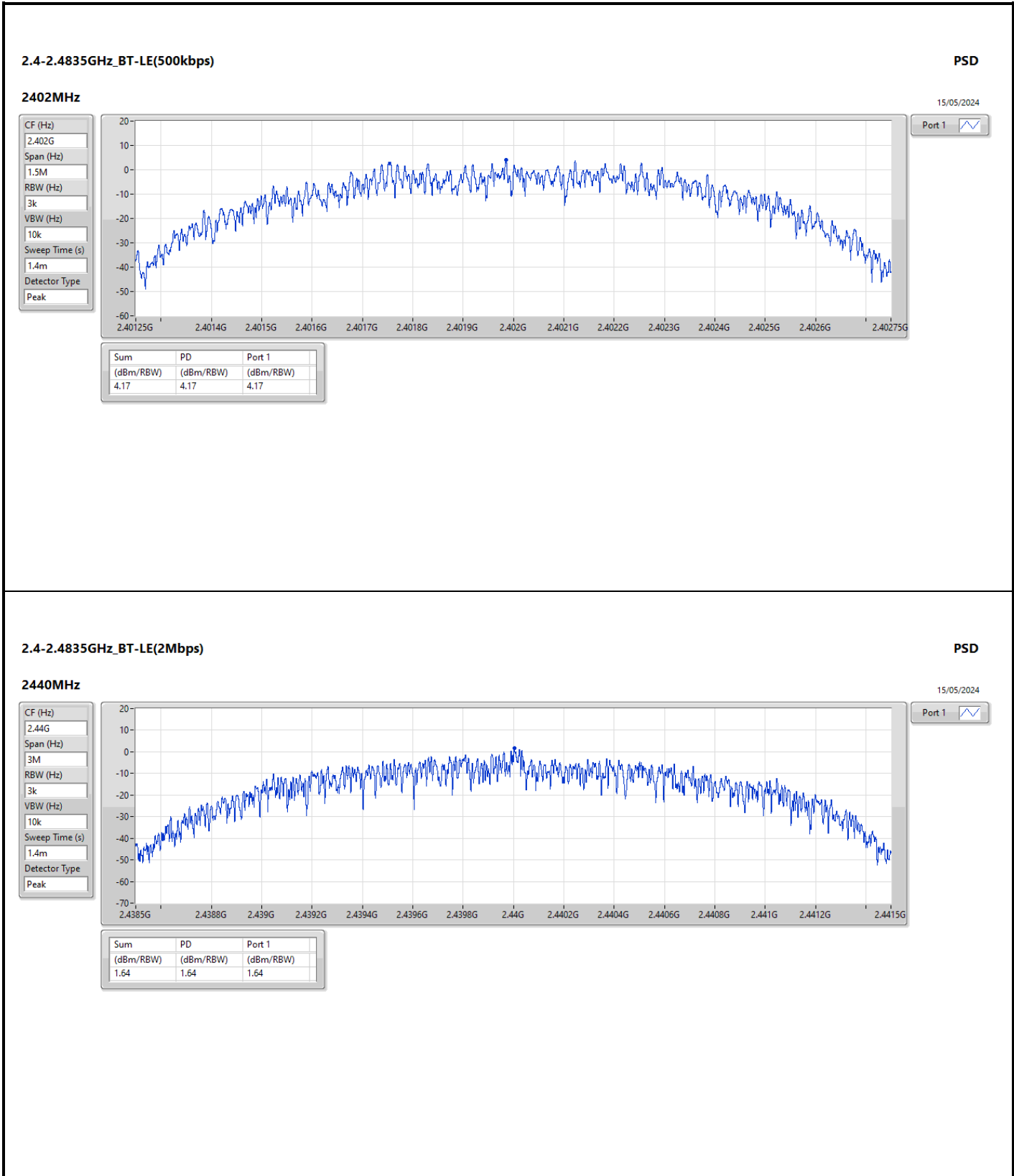



Summary

Mode	Result	Ref (Hz)	Ref (dBm)	Limit (dBm)	Freq (Hz)	Level (dBm)	Freq (Hz)	Level (dBm)	Freq (Hz)	Level (dBm)	Freq (Hz)	Level (dBm)	Freq (Hz)	Level (dBm)	Port
2.4-2.4835GHz	-	-	-	-	-	-	-	-	-	-	-	-	-	-	-
BT-LE(1Mbps)	Pass	2.44008G	18.95	-11.05	2.1685G	-55.33	2.4G	-35.19	2.4G	-35.23	2.5007G	-53.09	7.20527G	-41.68	1
BT-LE(125kbps)	Pass	2.43991G	16.14	-13.86	1.83715G	-54.74	2.39996G	-38.49	2.4G	-36.50	2.50202G	-52.68	21.94329G	-43.33	1
BT-LE(500kbps)	Pass	2.43975G	19.01	-10.99	2.3048G	-54.99	2.4G	-36.48	2.4G	-36.13	2.50178G	-53.06	23.12435G	-44.70	1
BT-LE(2Mbps)	Pass	2.44008G	19.23	-10.77	762.03M	-55.29	2.4G	-12.66	2.4G	-12.45	2.50318G	-52.88	16.20106G	-40.88	1

Result

Mode	Result	Ref (Hz)	Ref (dBm)	Limit (dBm)	Freq (Hz)	Level (dBm)	Freq (Hz)	Level (dBm)	Freq (Hz)	Level (dBm)	Freq (Hz)	Level (dBm)	Freq (Hz)	Level (dBm)	Port
BT-LE(1Mbps)	-	-	-	-	-	-	-	-	-	-	-	-	-	-	-
2402MHz	Pass	2.44008G	18.95	-11.05	2.1685G	-55.33	2.4G	-35.19	2.4G	-35.23	2.5007G	-53.09	7.20527G	-41.68	1
2440MHz	Pass	2.44008G	18.95	-11.05	2.17085G	-55.27	2.39988G	-44.94	2.4G	-46.68	2.50266G	-52.79	21.53273G	-43.77	1
2480MHz	Pass	2.44008G	18.95	-11.05	2.1591G	-55.20	2.39216G	-48.39	2.4G	-49.18	2.50174G	-52.77	21.55804G	-44.51	1
BT-LE(2Mbps)	-	-	-	-	-	-	-	-	-	-	-	-	-	-	-
2402MHz	Pass	2.44008G	19.23	-10.77	762.03M	-55.29	2.4G	-12.66	2.4G	-12.45	2.50318G	-52.88	16.20106G	-40.88	1
2440MHz	Pass	2.44008G	19.23	-10.77	946.5M	-56.14	2.39996G	-45.55	2.4G	-46.56	2.50346G	-53.74	17.28089G	-41.65	1
2478MHz	Pass	2.44008G	19.23	-10.77	2.16028G	-54.65	2.398G	-48.90	2.4G	-53.78	2.50158G	-54.08	16.2123G	-42.02	1
2480MHz	Pass	2.44008G	19.23	-10.77	1.94995G	-56.03	2.392G	-50.73	2.4G	-52.00	2.50342G	-53.97	16.23761G	-41.50	1
BT-LE(125kbps)	-	-	-	-	-	-	-	-	-	-	-	-	-	-	-
2402MHz	Pass	2.43991G	16.14	-13.86	1.83715G	-54.74	2.39996G	-38.49	2.4G	-36.50	2.50202G	-52.68	21.94329G	-43.33	1
2440MHz	Pass	2.43991G	16.14	-13.86	2.1168G	-55.04	2.39992G	-45.66	2.4G	-45.47	2.50262G	-52.23	21.60865G	-43.21	1
2480MHz	Pass	2.43991G	16.14	-13.86	2.08508G	-55.02	2.39988G	-46.79	2.4G	-46.45	2.50038G	-51.92	21.63115G	-43.96	1
BT-LE(500kbps)	-	-	-	-	-	-	-	-	-	-	-	-	-	-	-
2402MHz	Pass	2.43975G	19.01	-10.99	2.3048G	-54.99	2.4G	-36.48	2.4G	-36.13	2.50178G	-53.06	23.12435G	-44.70	1
2440MHz	Pass	2.43975G	19.01	-10.99	1.98403G	-54.38	2.39996G	-45.63	2.4G	-46.83	2.5001G	-52.19	21.61428G	-43.71	1
2480MHz	Pass	2.43975G	19.01	-10.99	2.30245G	-56.07	2.39964G	-48.70	2.4G	-50.69	2.50062G	-53.18	21.6199G	-44.05	1

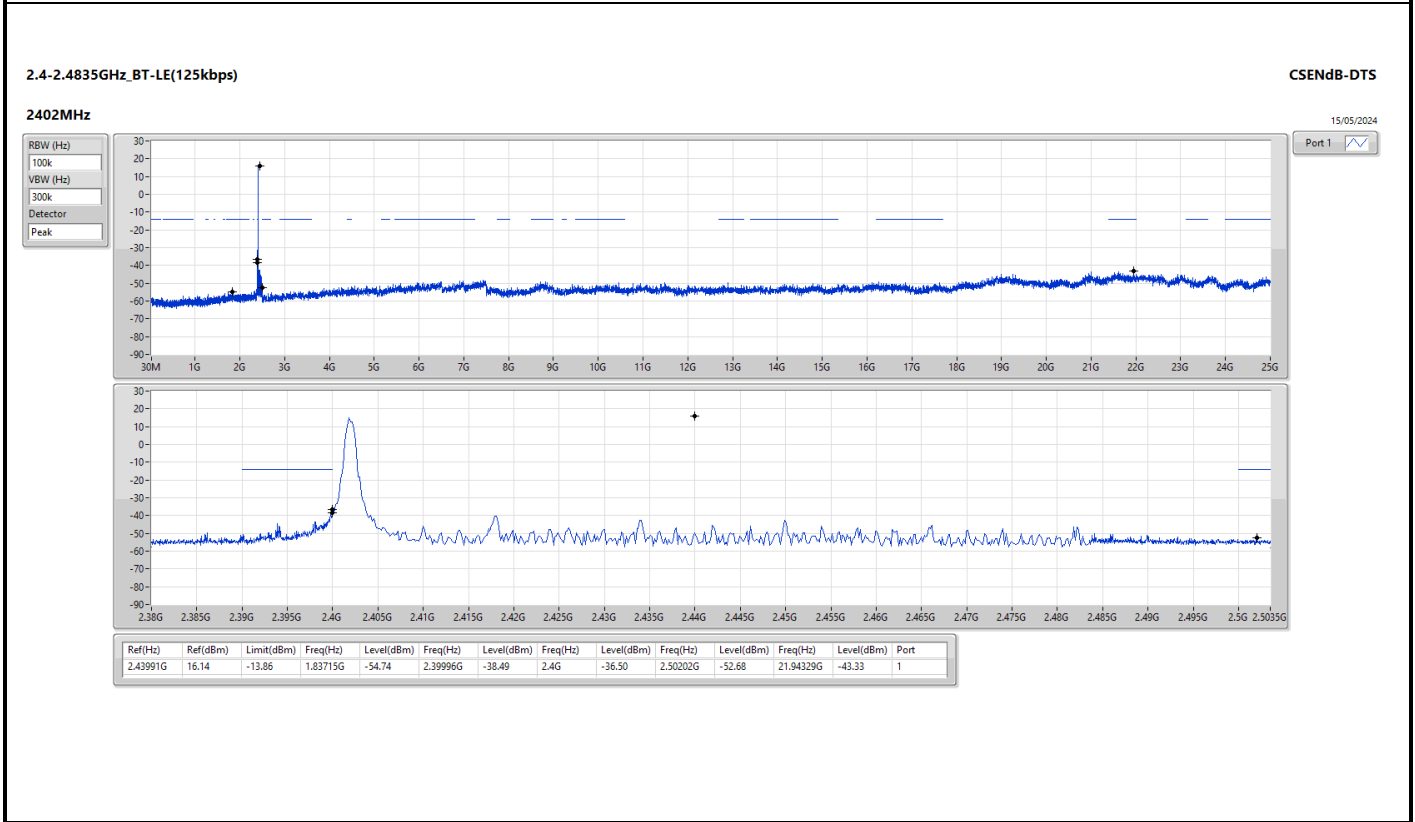
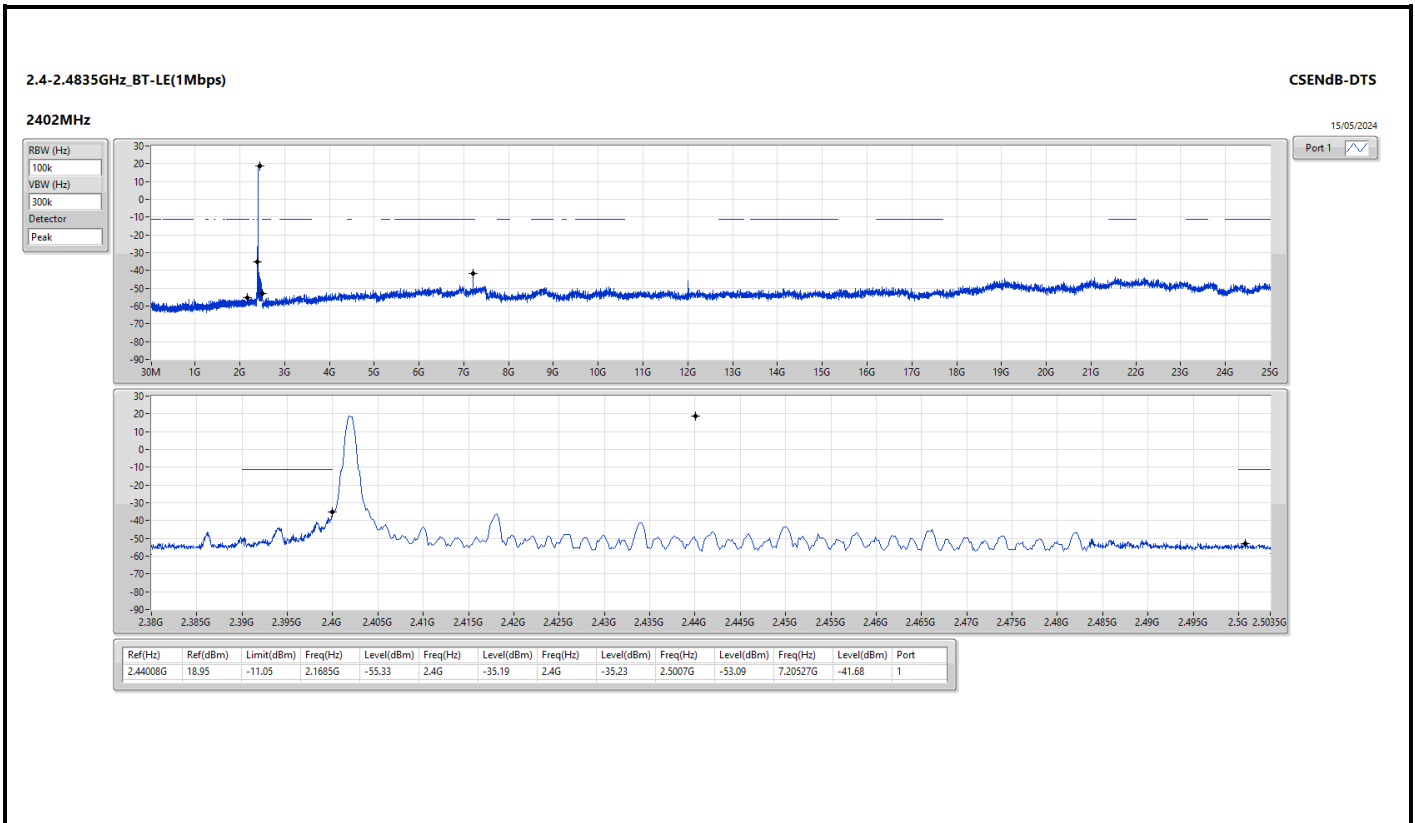

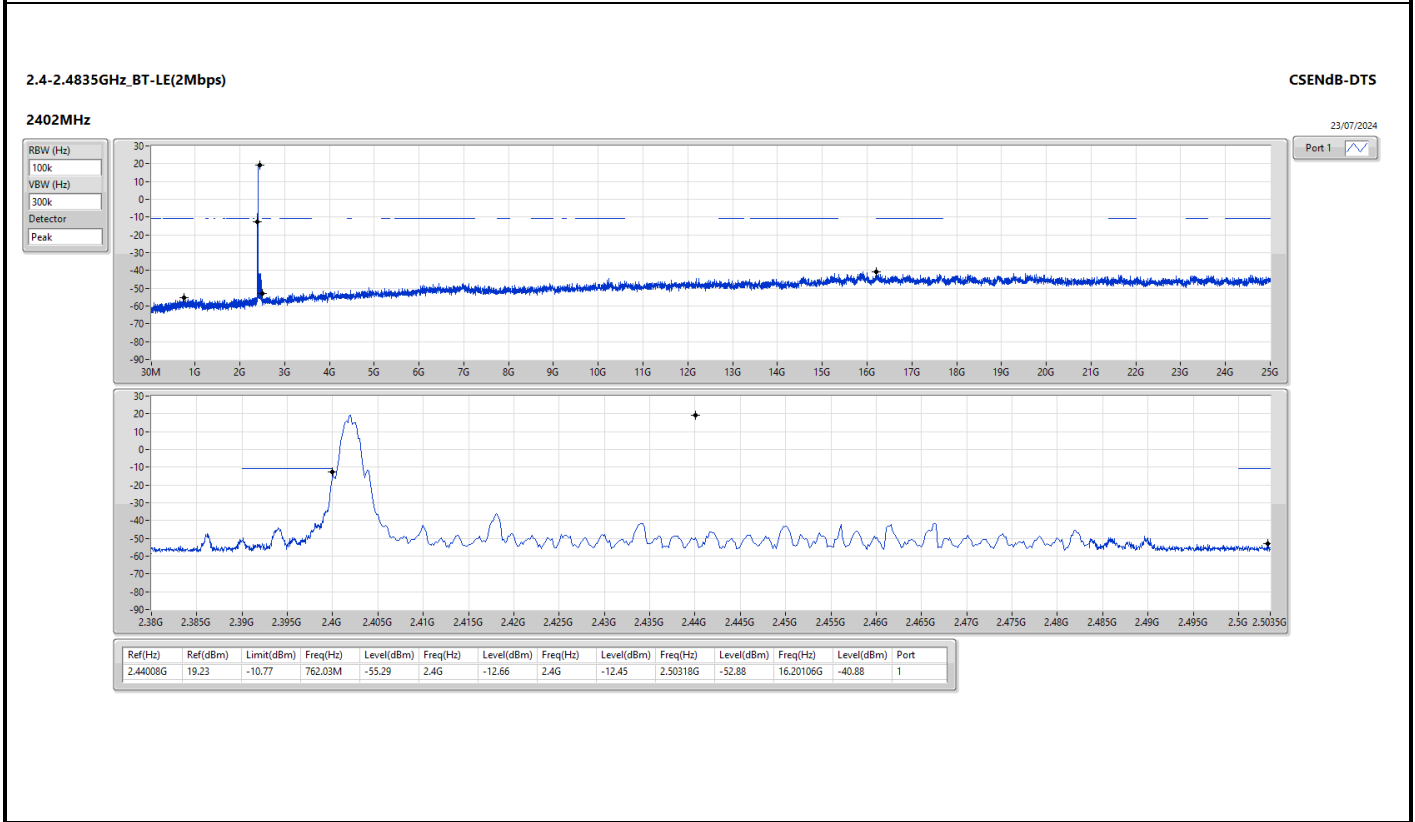
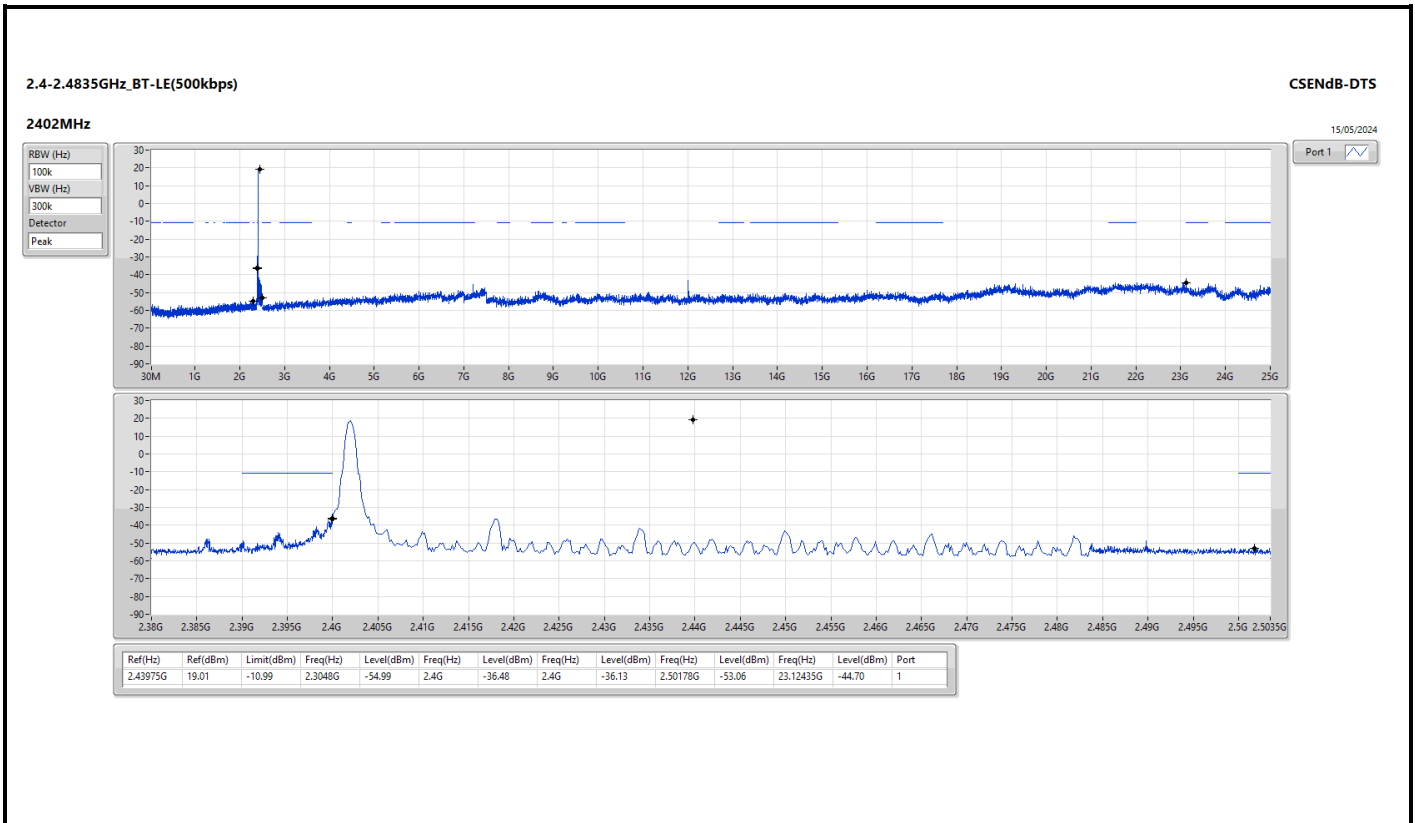



Summary

Mode	Result	Type	Freq (Hz)	Level (dBuV/m)	Limit (dBuV/m)	Margin (dB)	Dist (m)	Condition	Azimuth (°)	Height (m)
2.4-2.4835GHz	-	-	-	-	-	-	-	-	-	-
BT-LE(2Mbps)	Pass	PK	41.64M	34.11	40.00	-5.89	3	Vertical	0	1.00



Result

Mode	Result	Type	Freq (Hz)	Level (dBuV/m)	Limit (dBuV/m)	Margin (dB)	Dist (m)	Condition	Azimuth (°)	Height (m)
BT-LE(2Mbps)	-	-	-	-	-	-	-	-	-	-
2440MHz	Pass	PK	41.64M	34.11	40.00	-5.89	3	Vertical	0	1.00
2440MHz	Pass	PK	204.6M	33.46	43.50	-10.04	3	Vertical	0	1.00
2440MHz	Pass	PK	398.6M	29.49	46.00	-16.51	3	Vertical	0	1.00
2440MHz	Pass	PK	582.9M	34.99	46.00	-11.01	3	Vertical	0	1.00
2440MHz	Pass	PK	784.66M	36.64	46.00	-9.36	3	Vertical	0	1.00
2440MHz	Pass	PK	984.48M	38.66	54.00	-15.34	3	Vertical	0	1.00
2440MHz	Pass	PK	30M	30.81	40.00	-9.19	3	Horizontal	360	1.00
2440MHz	Pass	PK	204.6M	32.47	43.50	-11.03	3	Horizontal	360	1.00
2440MHz	Pass	PK	398.6M	29.48	46.00	-16.52	3	Horizontal	360	1.00
2440MHz	Pass	PK	586.78M	34.96	46.00	-11.04	3	Horizontal	360	1.00
2440MHz	Pass	PK	813.76M	36.24	46.00	-9.76	3	Horizontal	360	1.00
2440MHz	Pass	PK	992.24M	38.13	54.00	-15.87	3	Horizontal	360	1.00

2.4-2.4835GHz_BT-LE(2Mbps)

2440MHz_TX

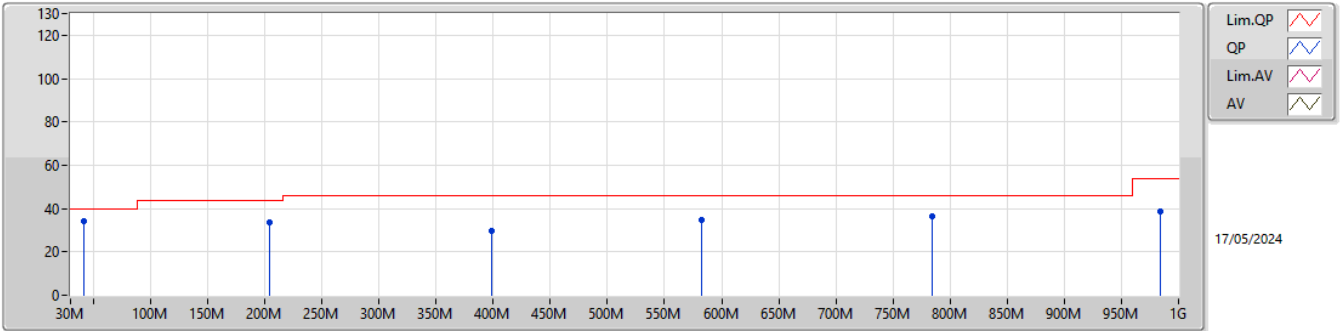

Type	Freq (Hz)	Level (dBuV/m)	Limit (dBuV/m)	Margin (dB)	Factor (dB)	Dist (m)	Condition	Azimuth (°)	Height (m)	Raw (dBuV)	AF (dB)	CL (dB)	PA (dB)
PK	41.64M	34.11	40.00	-5.89	-24.50	3	Vertical	0	1.00	58.61	19.37	0.46	44.33
PK	204.6M	33.46	43.50	-10.04	-27.78	3	Vertical	0	1.00	61.24	15.35	1.12	44.25
PK	398.6M	29.49	46.00	-16.51	-20.34	3	Vertical	0	1.00	49.83	22.14	1.45	43.93
PK	582.9M	34.99	46.00	-11.01	-16.02	3	Vertical	0	1.00	51.01	26.00	1.68	43.70
PK	784.66M	36.64	46.00	-9.36	-13.06	3	Vertical	0	1.00	49.70	28.31	2.07	43.44
PK	984.48M	38.66	54.00	-15.34	-10.39	3	Vertical	0	1.00	49.05	30.72	2.26	43.37

2.4-2.4835GHz_BT-LE(2Mbps)

2440MHz_TX

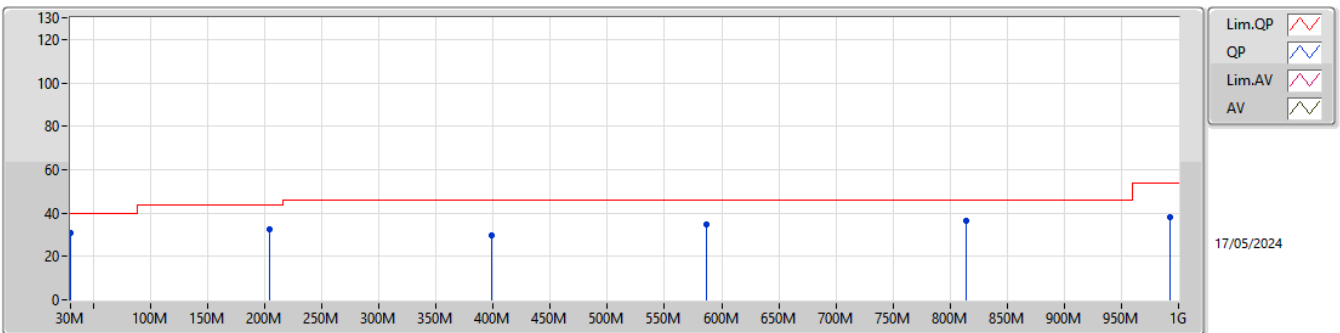

Type	Freq (Hz)	Level (dBuV/m)	Limit (dBuV/m)	Margin (dB)	Factor (dB)	Dist (m)	Condition	Azimuth (°)	Height (m)	Raw (dBuV)	AF (dB)	CL (dB)	PA (dB)
PK	30M	30.81	40.00	-9.19	-18.66	3	Horizontal	360	1.00	49.47	25.10	0.45	44.21
PK	204.6M	32.47	43.50	-11.03	-27.78	3	Horizontal	360	1.00	60.25	15.35	1.12	44.25
PK	398.6M	29.48	46.00	-16.52	-20.34	3	Horizontal	360	1.00	49.82	22.14	1.45	43.93
PK	586.78M	34.96	46.00	-11.04	-15.98	3	Horizontal	360	1.00	50.94	26.04	1.68	43.70
PK	813.76M	36.24	46.00	-9.76	-13.07	3	Horizontal	360	1.00	49.31	28.25	2.09	43.41
PK	992.24M	38.13	54.00	-15.87	-10.55	3	Horizontal	360	1.00	48.68	30.56	2.26	43.37



Summary

Mode	Result	Type	Freq (Hz)	Level (dBuV/m)	Limit (dBuV/m)	Margin (dB)	Dist (m)	Condition	Azimuth (°)	Height (m)
2.4-2.4835GHz	-	-	-	-	-	-	-	-	-	-
BT-LE(1Mbps)	Pass	AV	2.4835G	49.94	54.00	-4.06	3	Vertical	111	2.00
BT-LE(125kbps)	Pass	AV	2.4835G	50.09	54.00	-3.91	3	Vertical	109	1.99
BT-LE(500kbps)	Pass	AV	2.4835G	49.35	54.00	-4.65	3	Vertical	105	1.74
BT-LE(2Mbps)	Pass	AV	2.4835G	53.92	54.00	-0.08	3	Vertical	96	1.04



Result

Mode	Result	Type	Freq (Hz)	Level (dBuV/m)	Limit (dBuV/m)	Margin (dB)	Dist (m)	Condition	Azimuth (°)	Height (m)
BT-LE(1Mbps)	-	-	-	-	-	-	-	-	-	-
2402MHz	Pass	AV	2.3862G	44.86	54.00	-9.14	3	Vertical	74	1.35
2402MHz	Pass	AV	2.402G	116.39	Inf	-Inf	3	Vertical	74	1.35
2402MHz	Pass	PK	2.3864G	62.80	74.00	-11.20	3	Vertical	74	1.35
2402MHz	Pass	PK	2.4022G	117.50	Inf	-Inf	3	Vertical	74	1.35
2402MHz	Pass	AV	2.3832G	44.76	54.00	-9.24	3	Horizontal	156	1.50
2402MHz	Pass	AV	2.402G	107.54	Inf	-Inf	3	Horizontal	156	1.50
2402MHz	Pass	PK	2.3862G	58.82	74.00	-15.18	3	Horizontal	156	1.50
2402MHz	Pass	PK	2.4018G	108.62	Inf	-Inf	3	Horizontal	156	1.50
2402MHz	Pass	AV	4.804G	39.45	54.00	-14.55	3	Vertical	260	1.44
2402MHz	Pass	PK	4.80428G	46.63	74.00	-27.37	3	Vertical	260	1.44
2402MHz	Pass	AV	4.80396G	34.97	54.00	-19.03	3	Horizontal	110	3.00
2402MHz	Pass	PK	4.80416G	44.56	74.00	-29.44	3	Horizontal	110	3.00
2440MHz	Pass	AV	2.3848G	44.43	54.00	-9.57	3	Vertical	105	1.19
2440MHz	Pass	AV	2.44G	116.12	Inf	-Inf	3	Vertical	105	1.19
2440MHz	Pass	AV	2.4968G	45.15	54.00	-8.85	3	Vertical	105	1.19
2440MHz	Pass	PK	2.3876G	59.70	74.00	-14.30	3	Vertical	105	1.19
2440MHz	Pass	PK	2.4396G	117.19	Inf	-Inf	3	Vertical	105	1.19
2440MHz	Pass	PK	2.488G	64.47	74.00	-9.53	3	Vertical	105	1.19
2440MHz	Pass	AV	2.3484G	44.64	54.00	-9.36	3	Horizontal	147	2.37
2440MHz	Pass	AV	2.44G	107.17	Inf	-Inf	3	Horizontal	147	2.37
2440MHz	Pass	AV	2.494G	45.24	54.00	-8.76	3	Horizontal	147	2.37
2440MHz	Pass	PK	2.3668G	56.24	74.00	-17.76	3	Horizontal	147	2.37
2440MHz	Pass	PK	2.4404G	108.21	Inf	-Inf	3	Horizontal	147	2.37
2440MHz	Pass	PK	2.4964G	56.31	74.00	-17.69	3	Horizontal	147	2.37
2440MHz	Pass	AV	4.88G	37.78	54.00	-16.22	3	Vertical	259	2.64
2440MHz	Pass	PK	4.8806G	46.27	74.00	-27.73	3	Vertical	259	2.64
2440MHz	Pass	AV	4.87992G	33.34	54.00	-20.66	3	Horizontal	103	1.50
2440MHz	Pass	PK	4.87932G	43.35	74.00	-30.65	3	Horizontal	103	1.50
2480MHz	Pass	AV	2.48G	114.29	Inf	-Inf	3	Vertical	111	2.00
2480MHz	Pass	AV	2.4835G	49.94	54.00	-4.06	3	Vertical	111	2.00
2480MHz	Pass	PK	2.4798G	115.39	Inf	-Inf	3	Vertical	111	2.00
2480MHz	Pass	PK	2.4838G	65.10	74.00	-8.90	3	Vertical	111	2.00
2480MHz	Pass	AV	2.48G	105.07	Inf	-Inf	3	Horizontal	146	2.62
2480MHz	Pass	AV	2.4835G	46.26	54.00	-7.74	3	Horizontal	146	2.62
2480MHz	Pass	PK	2.4802G	106.10	Inf	-Inf	3	Horizontal	146	2.62
2480MHz	Pass	PK	2.488G	57.62	74.00	-16.38	3	Horizontal	146	2.62
2480MHz	Pass	AV	4.95964G	34.06	54.00	-19.94	3	Vertical	56	1.34
2480MHz	Pass	PK	4.9594G	44.23	74.00	-29.77	3	Vertical	56	1.34
2480MHz	Pass	AV	4.96008G	34.28	54.00	-19.72	3	Horizontal	209	1.69
2480MHz	Pass	PK	4.96064G	44.56	74.00	-29.44	3	Horizontal	209	1.69
BT-LE(2Mbps)	-	-	-	-	-	-	-	-	-	-
2402MHz	Pass	AV	2.3836G	46.22	54.00	-7.78	3	Vertical	66	1.50
2402MHz	Pass	AV	2.402G	114.36	Inf	-Inf	3	Vertical	66	1.50
2402MHz	Pass	PK	2.386G	59.94	74.00	-14.06	3	Vertical	66	1.50
2402MHz	Pass	PK	2.4026G	116.69	Inf	-Inf	3	Vertical	66	1.50
2402MHz	Pass	AV	2.3636G	46.06	54.00	-7.94	3	Horizontal	148	1.50
2402MHz	Pass	AV	2.402G	106.41	Inf	-Inf	3	Horizontal	148	1.50
2402MHz	Pass	PK	2.3862G	56.68	74.00	-17.32	3	Horizontal	148	1.50
2402MHz	Pass	PK	2.4014G	108.81	Inf	-Inf	3	Horizontal	148	1.50
2402MHz	Pass	AV	4.80389G	38.65	54.00	-15.35	3	Vertical	305	2.98
2402MHz	Pass	PK	4.80401G	45.98	74.00	-28.02	3	Vertical	305	2.98
2402MHz	Pass	AV	4.80406G	35.68	54.00	-18.32	3	Horizontal	109	2.99
2402MHz	Pass	PK	4.80501G	44.69	74.00	-29.31	3	Horizontal	109	2.99
2440MHz	Pass	AV	2.3852G	46.51	54.00	-7.49	3	Vertical	103	1.19
2440MHz	Pass	AV	2.44G	114.39	Inf	-Inf	3	Vertical	103	1.19
2440MHz	Pass	AV	2.4852G	46.58	54.00	-7.42	3	Vertical	103	1.19
2440MHz	Pass	PK	2.352G	56.22	74.00	-17.78	3	Vertical	103	1.19
2440MHz	Pass	PK	2.4404G	116.87	Inf	-Inf	3	Vertical	103	1.19
2440MHz	Pass	PK	2.4884G	64.41	74.00	-9.59	3	Vertical	103	1.19
2440MHz	Pass	AV	2.3648G	45.95	54.00	-8.05	3	Horizontal	149	1.50



Mode	Result	Type	Freq (Hz)	Level (dBuV/m)	Limit (dBuV/m)	Margin (dB)	Dist (m)	Condition	Azimuth (°)	Height (m)
2440MHz	Pass	AV	2.44G	104.92	Inf	-Inf	3	Horizontal	149	1.50
2440MHz	Pass	AV	2.4936G	46.96	54.00	-7.04	3	Horizontal	149	1.50
2440MHz	Pass	PK	2.3708G	56.55	74.00	-17.45	3	Horizontal	149	1.50
2440MHz	Pass	PK	2.4404G	107.25	Inf	-Inf	3	Horizontal	149	1.50
2440MHz	Pass	PK	2.4972G	57.12	74.00	-16.88	3	Horizontal	149	1.50
2440MHz	Pass	AV	4.87999G	35.82	54.00	-18.18	3	Vertical	200	2.00
2440MHz	Pass	PK	4.87881G	43.64	74.00	-30.36	3	Vertical	200	2.00
2440MHz	Pass	AV	4.87997G	34.23	54.00	-19.77	3	Horizontal	108	1.50
2440MHz	Pass	PK	4.87906G	43.12	74.00	-30.88	3	Horizontal	108	1.50
2478MHz	Pass	AV	2.478G	115.01	Inf	-Inf	3	Vertical	102	1.05
2478MHz	Pass	AV	2.4835G	48.86	54.00	-5.14	3	Vertical	102	1.05
2478MHz	Pass	PK	2.4776G	117.37	Inf	-Inf	3	Vertical	102	1.05
2478MHz	Pass	PK	2.486G	66.25	74.00	-7.75	3	Vertical	102	1.05
2478MHz	Pass	AV	2.478G	104.99	Inf	-Inf	3	Horizontal	154	2.18
2478MHz	Pass	AV	2.5G	47.00	54.00	-7.00	3	Horizontal	154	2.18
2478MHz	Pass	PK	2.4776G	107.34	Inf	-Inf	3	Horizontal	154	2.18
2478MHz	Pass	PK	2.4856G	57.83	74.00	-16.17	3	Horizontal	154	2.18
2478MHz	Pass	AV	4.95596G	36.51	54.00	-17.49	3	Vertical	6	2.78
2478MHz	Pass	PK	4.95608G	44.71	74.00	-29.29	3	Vertical	6	2.78
2478MHz	Pass	AV	4.956G	34.02	54.00	-19.98	3	Horizontal	213	1.50
2478MHz	Pass	PK	4.95484G	43.87	74.00	-30.13	3	Horizontal	213	1.50
2480MHz	Pass	AV	2.48G	110.53	Inf	-Inf	3	Vertical	96	1.04
2480MHz	Pass	AV	2.4835G	53.92	54.00	-0.08	3	Vertical	96	1.04
2480MHz	Pass	PK	2.4796G	112.76	Inf	-Inf	3	Vertical	96	1.04
2480MHz	Pass	PK	2.4838G	63.98	74.00	-10.02	3	Vertical	96	1.04
2480MHz	Pass	AV	2.48G	101.96	Inf	-Inf	3	Horizontal	169	1.18
2480MHz	Pass	AV	2.4835G	48.68	54.00	-5.32	3	Horizontal	169	1.18
2480MHz	Pass	PK	2.48G	104.57	Inf	-Inf	3	Horizontal	169	1.18
2480MHz	Pass	PK	2.4835G	58.28	74.00	-15.72	3	Horizontal	169	1.18
2480MHz	Pass	AV	4.95981G	32.77	54.00	-21.23	3	Vertical	56	1.48
2480MHz	Pass	PK	4.95908G	42.35	74.00	-31.65	3	Vertical	56	1.48
2480MHz	Pass	AV	4.96115G	31.69	54.00	-22.31	3	Horizontal	227	1.16
2480MHz	Pass	PK	4.96214G	42.60	74.00	-31.40	3	Horizontal	227	1.16
BT-LE(125kbps)	-	-	-	-	-	-	-	-	-	-
2402MHz	Pass	AV	2.3874G	43.82	54.00	-10.18	3	Vertical	67	1.50
2402MHz	Pass	AV	2.402G	115.95	Inf	-Inf	3	Vertical	67	1.50
2402MHz	Pass	PK	2.3856G	60.05	74.00	-13.95	3	Vertical	67	1.50
2402MHz	Pass	PK	2.4022G	117.10	Inf	-Inf	3	Vertical	67	1.50
2402MHz	Pass	AV	2.3888G	43.60	54.00	-10.40	3	Horizontal	145	1.86
2402MHz	Pass	AV	2.402G	108.61	Inf	-Inf	3	Horizontal	145	1.86
2402MHz	Pass	PK	2.384G	56.13	74.00	-17.87	3	Horizontal	145	1.86
2402MHz	Pass	PK	2.4022G	109.77	Inf	-Inf	3	Horizontal	145	1.86
2402MHz	Pass	AV	4.804G	38.96	54.00	-15.04	3	Vertical	305	2.62
2402MHz	Pass	PK	4.80356G	47.34	74.00	-26.66	3	Vertical	305	2.62
2402MHz	Pass	AV	4.80404G	33.90	54.00	-20.10	3	Horizontal	110	3.00
2402MHz	Pass	PK	4.80464G	44.08	74.00	-29.92	3	Horizontal	110	3.00
2440MHz	Pass	AV	2.354G	43.73	54.00	-10.27	3	Vertical	113	2.46
2440MHz	Pass	AV	2.44G	116.60	Inf	-Inf	3	Vertical	113	2.46
2440MHz	Pass	AV	2.4864G	44.50	54.00	-9.50	3	Vertical	113	2.46
2440MHz	Pass	PK	2.362G	56.99	74.00	-17.01	3	Vertical	113	2.46
2440MHz	Pass	PK	2.4396G	117.82	Inf	-Inf	3	Vertical	113	2.46
2440MHz	Pass	PK	2.488G	62.32	74.00	-11.68	3	Vertical	113	2.46
2440MHz	Pass	AV	2.3788G	43.61	54.00	-10.39	3	Horizontal	145	2.37
2440MHz	Pass	AV	2.44G	107.77	Inf	-Inf	3	Horizontal	145	2.37
2440MHz	Pass	AV	2.4984G	44.46	54.00	-9.54	3	Horizontal	145	2.37
2440MHz	Pass	PK	2.3576G	56.67	74.00	-17.33	3	Horizontal	145	2.37
2440MHz	Pass	PK	2.4404G	108.93	Inf	-Inf	3	Horizontal	145	2.37
2440MHz	Pass	PK	2.4844G	57.34	74.00	-16.66	3	Horizontal	145	2.37
2440MHz	Pass	AV	4.88G	35.79	54.00	-18.21	3	Vertical	259	2.58
2440MHz	Pass	PK	4.88048G	45.79	74.00	-28.21	3	Vertical	259	2.58
2440MHz	Pass	AV	4.88016G	32.14	54.00	-21.86	3	Horizontal	108	1.50
2440MHz	Pass	PK	4.87936G	43.69	74.00	-30.31	3	Horizontal	108	1.50



Mode	Result	Type	Freq (Hz)	Level (dBuV/m)	Limit (dBuV/m)	Margin (dB)	Dist (m)	Condition	Azimuth (°)	Height (m)
2480MHz	Pass	AV	2.48G	114.96	Inf	-Inf	3	Vertical	109	1.99
2480MHz	Pass	AV	2.4835G	50.09	54.00	-3.91	3	Vertical	109	1.99
2480MHz	Pass	PK	2.4802G	116.12	Inf	-Inf	3	Vertical	109	1.99
2480MHz	Pass	PK	2.4838G	65.49	74.00	-8.51	3	Vertical	109	1.99
2480MHz	Pass	AV	2.48G	105.47	Inf	-Inf	3	Horizontal	146	2.62
2480MHz	Pass	AV	2.4835G	45.57	54.00	-8.43	3	Horizontal	146	2.62
2480MHz	Pass	PK	2.4798G	106.67	Inf	-Inf	3	Horizontal	146	2.62
2480MHz	Pass	PK	2.4838G	59.09	74.00	-14.91	3	Horizontal	146	2.62
2480MHz	Pass	AV	4.96016G	32.64	54.00	-21.36	3	Vertical	55	1.38
2480MHz	Pass	PK	4.95952G	43.84	74.00	-30.16	3	Vertical	55	1.38
2480MHz	Pass	AV	4.96017G	33.29	54.00	-20.71	3	Horizontal	208	1.68
2480MHz	Pass	PK	4.95956G	44.46	74.00	-29.54	3	Horizontal	208	1.68
BT-LE(500kbps)	-	-	-	-	-	-	-	-	-	-
2402MHz	Pass	AV	2.3538G	43.69	54.00	-10.31	3	Vertical	94	1.97
2402MHz	Pass	AV	2.402G	116.40	Inf	-Inf	3	Vertical	94	1.97
2402MHz	Pass	PK	2.386G	63.79	74.00	-10.21	3	Vertical	94	1.97
2402MHz	Pass	PK	2.4022G	117.50	Inf	-Inf	3	Vertical	94	1.97
2402MHz	Pass	AV	2.3886G	43.68	54.00	-10.32	3	Horizontal	146	1.86
2402MHz	Pass	AV	2.402G	108.22	Inf	-Inf	3	Horizontal	146	1.86
2402MHz	Pass	PK	2.3858G	59.05	74.00	-14.95	3	Horizontal	146	1.86
2402MHz	Pass	PK	2.4022G	109.34	Inf	-Inf	3	Horizontal	146	1.86
2402MHz	Pass	AV	4.80406G	39.54	54.00	-14.46	3	Vertical	307	2.78
2402MHz	Pass	PK	4.8044G	47.04	74.00	-26.96	3	Vertical	307	2.78
2402MHz	Pass	AV	4.80409G	34.61	54.00	-19.39	3	Horizontal	110	3.00
2402MHz	Pass	PK	4.80455G	44.83	74.00	-29.17	3	Horizontal	110	3.00
2440MHz	Pass	AV	2.3884G	43.61	54.00	-10.39	3	Vertical	113	2.46
2440MHz	Pass	AV	2.44G	116.60	Inf	-Inf	3	Vertical	113	2.46
2440MHz	Pass	AV	2.486G	44.43	54.00	-9.57	3	Vertical	113	2.46
2440MHz	Pass	PK	2.388G	57.29	74.00	-16.71	3	Vertical	113	2.46
2440MHz	Pass	PK	2.4396G	117.71	Inf	-Inf	3	Vertical	113	2.46
2440MHz	Pass	PK	2.488G	65.19	74.00	-8.81	3	Vertical	113	2.46
2440MHz	Pass	AV	2.386G	43.62	54.00	-10.38	3	Horizontal	146	2.37
2440MHz	Pass	AV	2.44G	107.54	Inf	-Inf	3	Horizontal	146	2.37
2440MHz	Pass	AV	2.4876G	44.35	54.00	-9.65	3	Horizontal	146	2.37
2440MHz	Pass	PK	2.37G	57.71	74.00	-16.29	3	Horizontal	146	2.37
2440MHz	Pass	PK	2.4404G	108.65	Inf	-Inf	3	Horizontal	146	2.37
2440MHz	Pass	PK	2.4904G	57.21	74.00	-16.79	3	Horizontal	146	2.37
2440MHz	Pass	AV	4.88006G	36.76	54.00	-17.24	3	Vertical	259	2.56
2440MHz	Pass	PK	4.88059G	45.73	74.00	-28.27	3	Vertical	259	2.56
2440MHz	Pass	AV	4.88023G	32.75	54.00	-21.25	3	Horizontal	107	1.50
2440MHz	Pass	PK	4.87952G	43.70	74.00	-30.30	3	Horizontal	107	1.50
2480MHz	Pass	AV	2.48G	114.24	Inf	-Inf	3	Vertical	105	1.74
2480MHz	Pass	AV	2.4835G	49.35	54.00	-4.65	3	Vertical	105	1.74
2480MHz	Pass	PK	2.4798G	115.34	Inf	-Inf	3	Vertical	105	1.74
2480MHz	Pass	PK	2.4842G	65.52	74.00	-8.48	3	Vertical	105	1.74
2480MHz	Pass	AV	2.48G	105.06	Inf	-Inf	3	Horizontal	148	2.61
2480MHz	Pass	AV	2.4835G	45.14	54.00	-8.86	3	Horizontal	148	2.61
2480MHz	Pass	PK	2.4798G	106.17	Inf	-Inf	3	Horizontal	148	2.61
2480MHz	Pass	PK	2.4838G	59.07	74.00	-14.93	3	Horizontal	148	2.61
2480MHz	Pass	AV	4.96001G	33.17	54.00	-20.83	3	Vertical	55	1.36
2480MHz	Pass	PK	4.96068G	44.69	74.00	-29.31	3	Vertical	55	1.36
2480MHz	Pass	AV	4.96G	33.18	54.00	-20.82	3	Horizontal	207	1.96
2480MHz	Pass	PK	4.96053G	44.05	74.00	-29.95	3	Horizontal	207	1.96

2.4-2.4835GHz_BT-LE(1Mbps)

2480MHz_TX

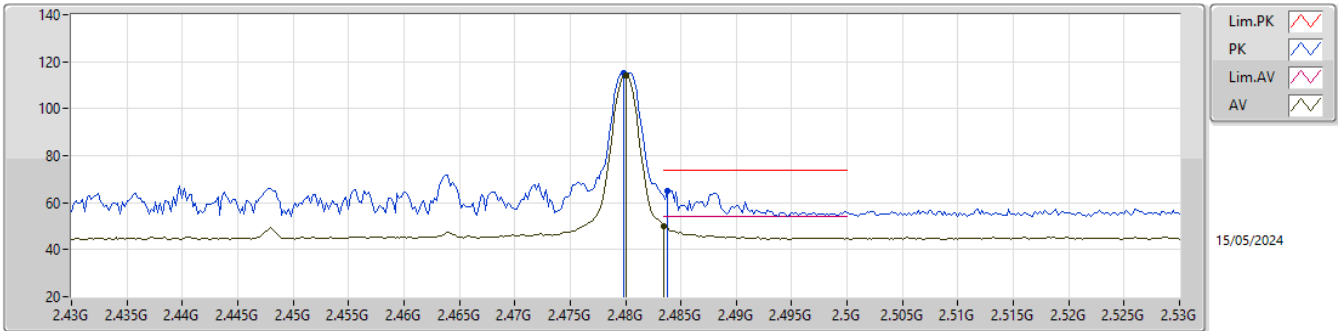

Type	Freq (Hz)	Level (dBuV/m)	Limit (dBuV/m)	Margin (dB)	Factor (dB)	Dist (m)	Condition	Azimuth (°)	Height (m)	Raw (dBuV)	AF (dB)	CL (dB)	PA (dB)
AV	2.48G	114.29	Inf	-Inf	31.10	3	Vertical	111	2.00	83.19	27.90	3.20	-
AV	2.4835G	49.94	54.00	-4.06	31.15	3	Vertical	111	2.00	18.79	27.94	3.21	-
PK	2.4798G	115.39	Inf	-Inf	31.10	3	Vertical	111	2.00	84.29	27.90	3.20	-
PK	2.4838G	65.10	74.00	-8.90	31.15	3	Vertical	111	2.00	33.95	27.94	3.21	-

2.4-2.4835GHz_BT-LE(1Mbps)

2480MHz_TX

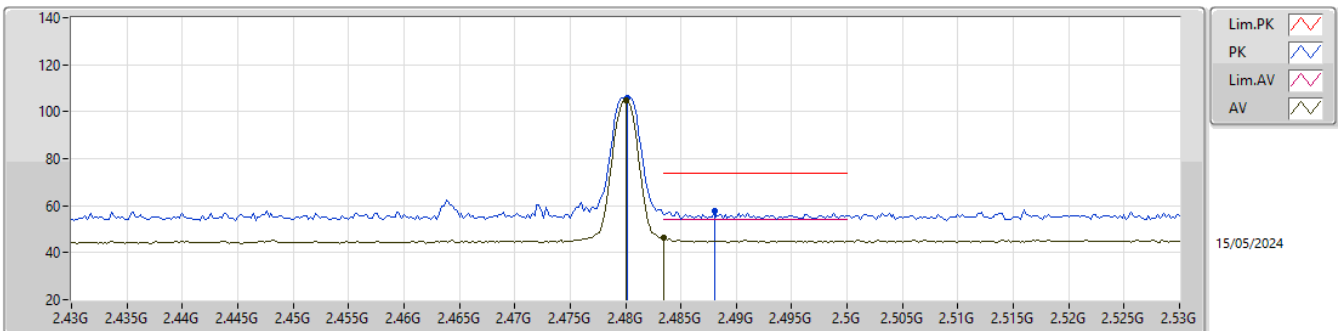

Type	Freq (Hz)	Level (dBuV/m)	Limit (dBuV/m)	Margin (dB)	Factor (dB)	Dist (m)	Condition	Azimuth (°)	Height (m)	Raw (dBuV)	AF (dB)	CL (dB)	PA (dB)
AV	2.48G	105.07	Inf	-Inf	31.10	3	Horizontal	146	2.62	73.97	27.90	3.20	-
AV	2.4835G	46.26	54.00	-7.74	31.15	3	Horizontal	146	2.62	15.11	27.94	3.21	-
PK	2.4802G	106.10	Inf	-Inf	31.10	3	Horizontal	146	2.62	75.00	27.90	3.20	-
PK	2.488G	57.62	74.00	-16.38	31.19	3	Horizontal	146	2.62	26.43	27.98	3.21	-

2.4-2.4835GHz_BT-LE(1Mbps)

2480MHz_TX

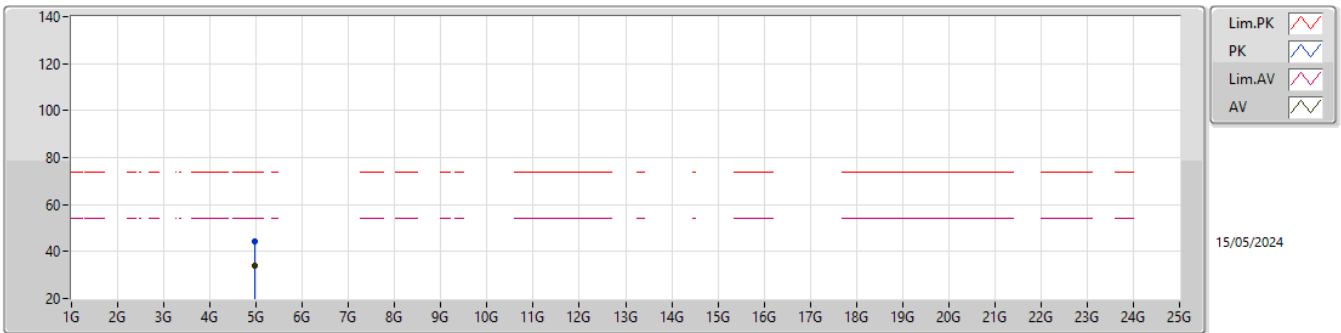

Type	Freq (Hz)	Level (dBuV/m)	Limit (dBuV/m)	Margin (dB)	Factor (dB)	Dist (m)	Condition	Azimuth (°)	Height (m)	Raw (dBuV)	AF (dB)	CL (dB)	PA (dB)
AV	4.95964G	34.06	54.00	-19.94	-6.05	3	Vertical	56	1.34	40.11	33.30	4.70	44.05
PK	4.9594G	44.23	74.00	-29.77	-6.06	3	Vertical	56	1.34	50.29	33.29	4.70	44.05

2.4-2.4835GHz_BT-LE(1Mbps)

2480MHz_TX

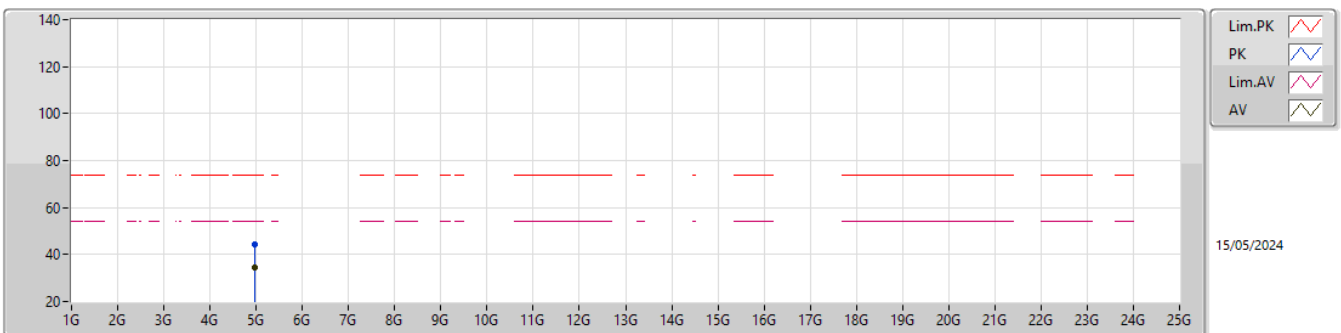

Type	Freq (Hz)	Level (dBuV/m)	Limit (dBuV/m)	Margin (dB)	Factor (dB)	Dist (m)	Condition	Azimuth (°)	Height (m)	Raw (dBuV)	AF (dB)	CL (dB)	PA (dB)
AV	4.96008G	34.28	54.00	-19.72	-6.05	3	Horizontal	209	1.69	40.33	33.30	4.70	44.05
PK	4.9604G	44.56	74.00	-29.44	-6.04	3	Horizontal	209	1.69	50.60	33.31	4.70	44.05

2.4-2.4835GHz_BT-LE(125kbps)

2480MHz_TX

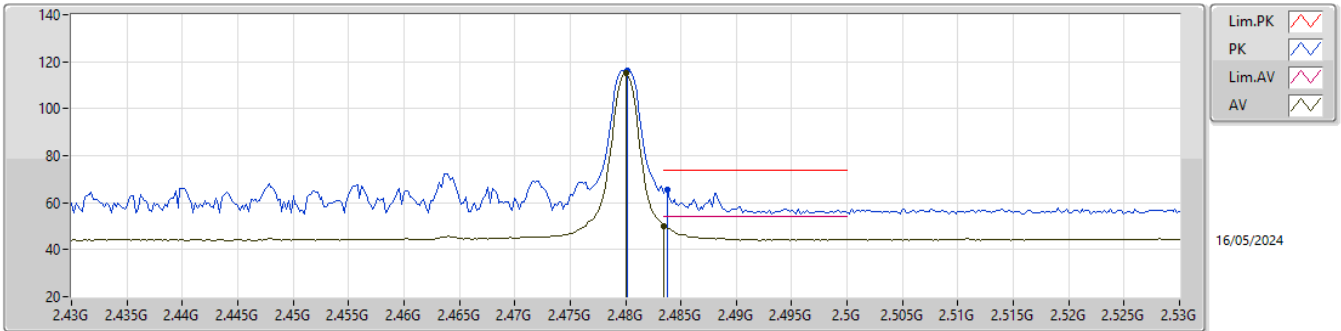

Type	Freq (Hz)	Level (dBuV/m)	Limit (dBuV/m)	Margin (dB)	Factor (dB)	Dist (m)	Condition	Azimuth (°)	Height (m)	Raw (dBuV)	AF (dB)	CL (dB)	PA (dB)
AV	2.48G	114.96	Inf	-Inf	31.10	3	Vertical	109	1.99	83.86	27.90	3.20	-
AV	2.4835G	50.09	54.00	-3.91	31.15	3	Vertical	109	1.99	18.94	27.94	3.21	-
PK	2.4802G	116.12	Inf	-Inf	31.10	3	Vertical	109	1.99	85.02	27.90	3.20	-
PK	2.4838G	65.49	74.00	-8.51	31.15	3	Vertical	109	1.99	34.34	27.94	3.21	-

2.4-2.4835GHz_BT-LE(125kbps)

2480MHz_TX

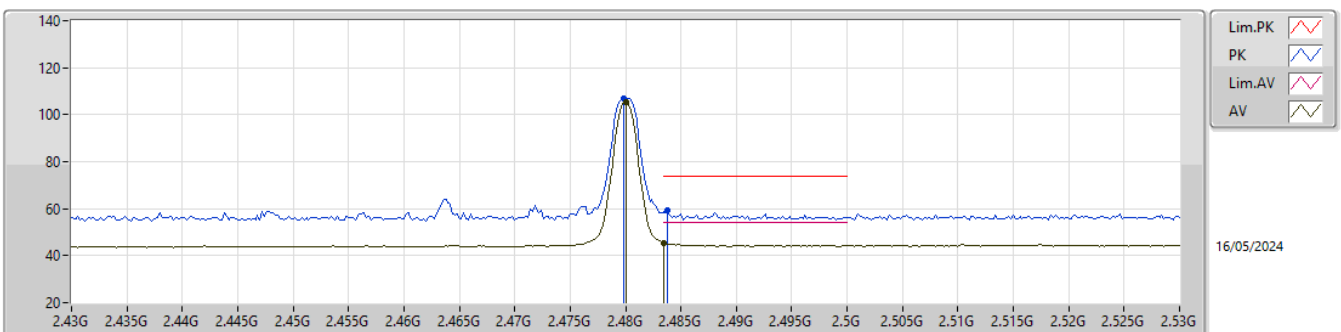

Type	Freq (Hz)	Level (dBuV/m)	Limit (dBuV/m)	Margin (dB)	Factor (dB)	Dist (m)	Condition	Azimuth (°)	Height (m)	Raw (dBuV)	AF (dB)	CL (dB)	PA (dB)
AV	2.48G	105.47	Inf	-Inf	31.10	3	Horizontal	146	2.62	74.37	27.90	3.20	-
AV	2.4835G	45.57	54.00	-8.43	31.15	3	Horizontal	146	2.62	14.42	27.94	3.21	-
PK	2.4798G	106.67	Inf	-Inf	31.10	3	Horizontal	146	2.62	75.57	27.90	3.20	-
PK	2.4838G	59.09	74.00	-14.91	31.15	3	Horizontal	146	2.62	27.94	27.94	3.21	-

2.4-2.4835GHz_BT-LE(125kbps)

2480MHz_TX

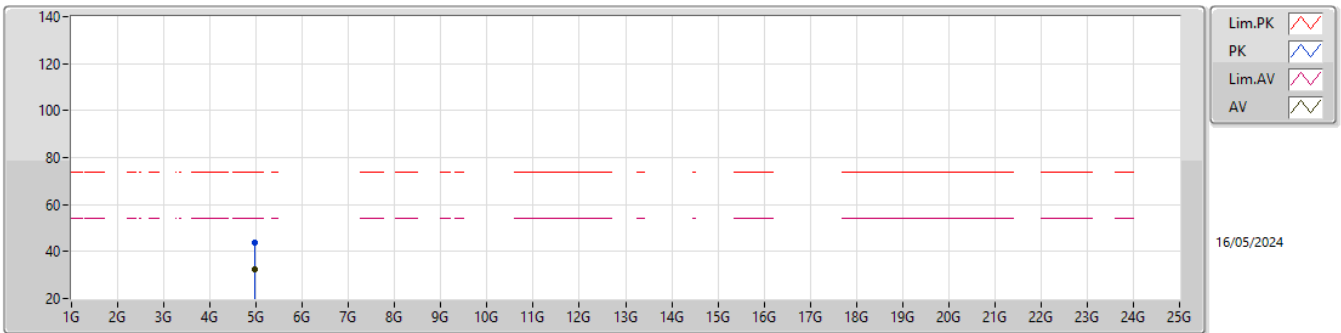

Type	Freq (Hz)	Level (dBuV/m)	Limit (dBuV/m)	Margin (dB)	Factor (dB)	Dist (m)	Condition	Azimuth (°)	Height (m)	Raw (dBuV)	AF (dB)	CL (dB)	PA (dB)
AV	4.96016G	32.64	54.00	-21.36	-6.05	3	Vertical	55	1.38	38.69	33.30	4.70	44.05
PK	4.95952G	43.84	74.00	-30.16	-6.05	3	Vertical	55	1.38	49.89	33.30	4.70	44.05

2.4-2.4835GHz_BT-LE(125kbps)

2480MHz_TX

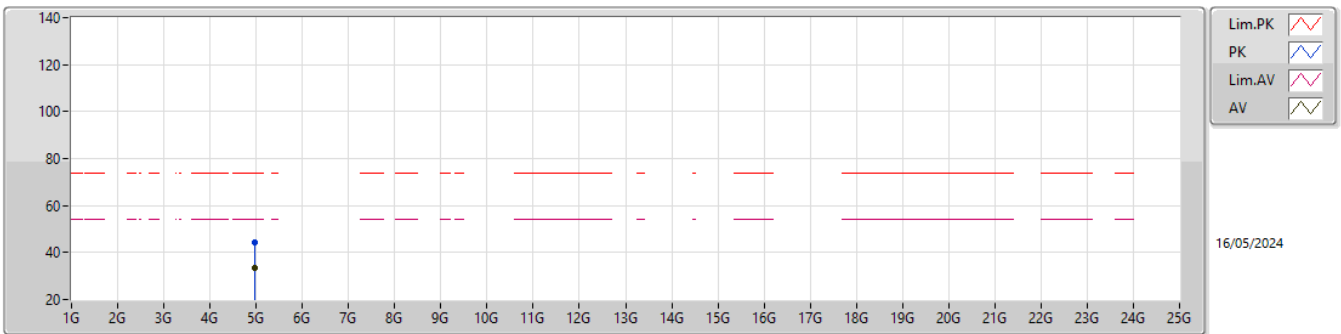

Type	Freq (Hz)	Level (dBuV/m)	Limit (dBuV/m)	Margin (dB)	Factor (dB)	Dist (m)	Condition	Azimuth (°)	Height (m)	Raw (dBuV)	AF (dB)	CL (dB)	PA (dB)
AV	4.96017G	33.29	54.00	-20.71	-6.05	3	Horizontal	208	1.68	39.34	33.30	4.70	44.05
PK	4.95956G	44.46	74.00	-29.54	-6.05	3	Horizontal	208	1.68	50.51	33.30	4.70	44.05

2.4-2.4835GHz_BT-LE(500kbps)

2480MHz_TX

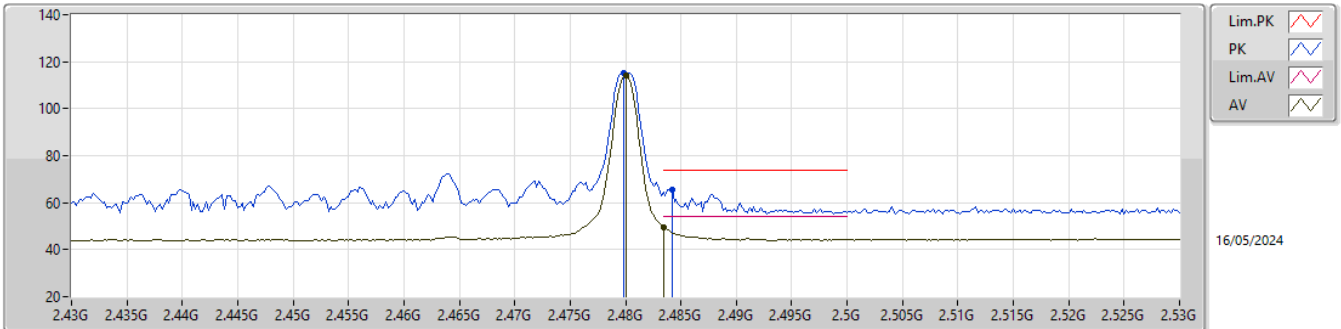

Type	Freq (Hz)	Level (dBuV/m)	Limit (dBuV/m)	Margin (dB)	Factor (dB)	Dist (m)	Condition	Azimuth (°)	Height (m)	Raw (dBuV)	AF (dB)	CL (dB)	PA (dB)
AV	2.48G	114.24	Inf	-Inf	31.10	3	Vertical	105	1.74	83.14	27.90	3.20	-
AV	2.4835G	49.35	54.00	-4.65	31.15	3	Vertical	105	1.74	18.20	27.94	3.21	-
PK	2.4798G	115.34	Inf	-Inf	31.10	3	Vertical	105	1.74	84.24	27.90	3.20	-
PK	2.4842G	65.52	74.00	-8.48	31.15	3	Vertical	105	1.74	34.37	27.94	3.21	-

2.4-2.4835GHz_BT-LE(500kbps)

2480MHz_TX

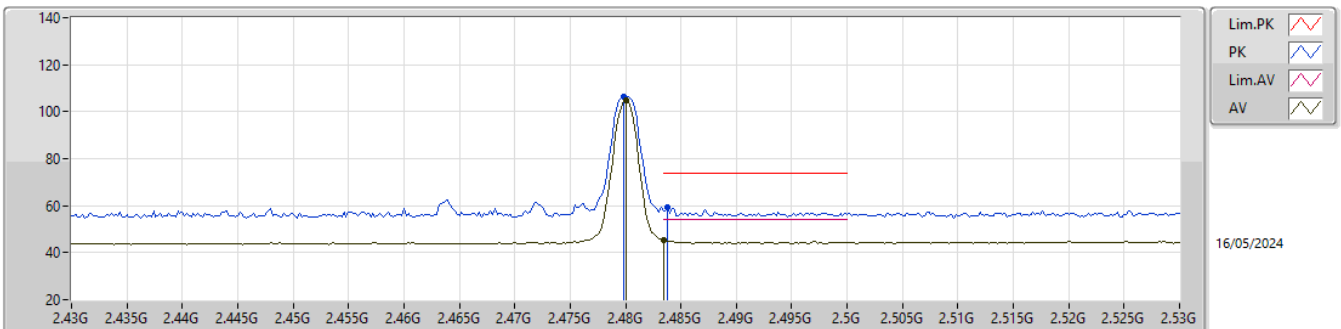

Type	Freq (Hz)	Level (dBuV/m)	Limit (dBuV/m)	Margin (dB)	Factor (dB)	Dist (m)	Condition	Azimuth (°)	Height (m)	Raw (dBuV)	AF (dB)	CL (dB)	PA (dB)
AV	2.48G	105.06	Inf	-Inf	31.10	3	Horizontal	148	2.61	73.96	27.90	3.20	-
AV	2.4835G	45.14	54.00	-8.86	31.15	3	Horizontal	148	2.61	13.99	27.94	3.21	-
PK	2.4798G	106.17	Inf	-Inf	31.10	3	Horizontal	148	2.61	75.07	27.90	3.20	-
PK	2.4838G	59.07	74.00	-14.93	31.15	3	Horizontal	148	2.61	27.92	27.94	3.21	-

2.4-2.4835GHz_BT-LE(500kbps)

2480MHz_TX

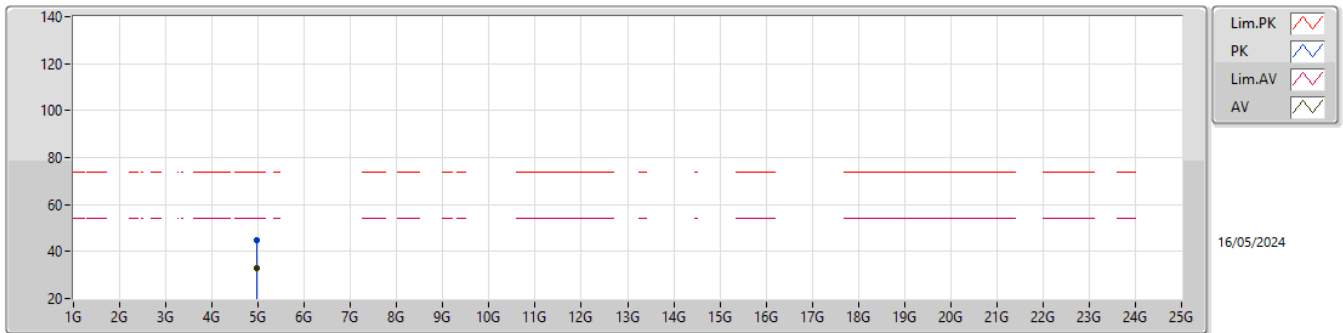

Type	Freq (Hz)	Level (dBuV/m)	Limit (dBuV/m)	Margin (dB)	Factor (dB)	Dist (m)	Condition	Azimuth (°)	Height (m)	Raw (dBuV)	AF (dB)	CL (dB)	PA (dB)
AV	4.96001G	33.17	54.00	-20.83	-6.05	3	Vertical	55	1.36	39.22	33.30	4.70	44.05
PK	4.96068G	44.69	74.00	-29.31	-6.04	3	Vertical	55	1.36	50.73	33.31	4.70	44.05

2.4-2.4835GHz_BT-LE(500kbps)

2480MHz_TX

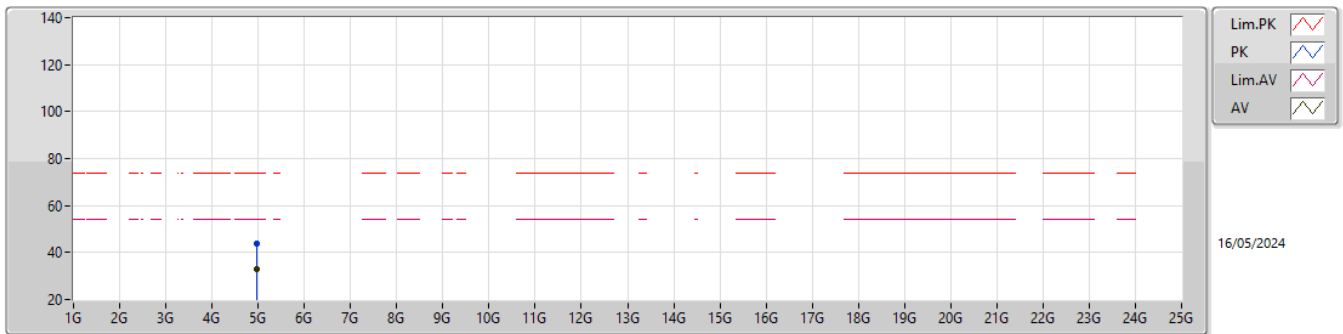

Type	Freq (Hz)	Level (dBuV/m)	Limit (dBuV/m)	Margin (dB)	Factor (dB)	Dist (m)	Condition	Azimuth (°)	Height (m)	Raw (dBuV)	AF (dB)	CL (dB)	PA (dB)
AV	4.96G	33.18	54.00	-20.82	-6.05	3	Horizontal	207	1.96	39.23	33.30	4.70	44.05
PK	4.96053G	44.05	74.00	-29.95	-6.04	3	Horizontal	207	1.96	50.09	33.31	4.70	44.05

2.4-2.4835GHz_BT-LE(2Mbps)

2480MHz_TX

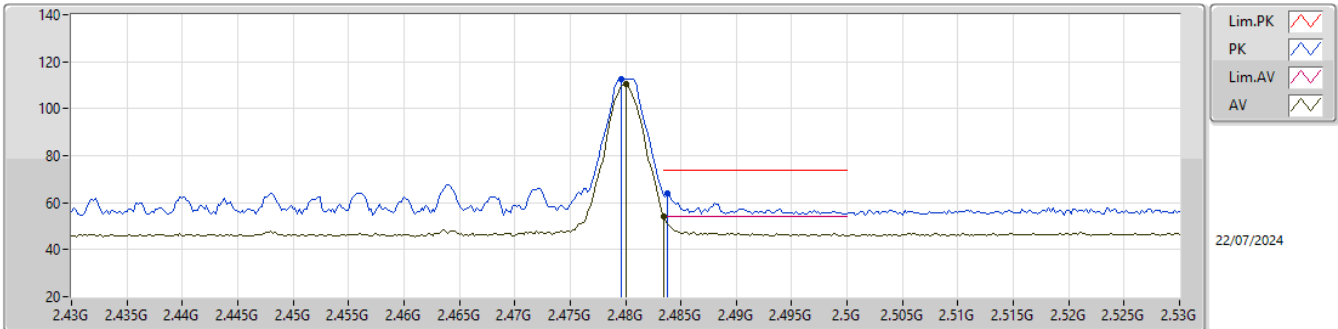

Type	Freq (Hz)	Level (dBuV/m)	Limit (dBuV/m)	Margin (dB)	Factor (dB)	Dist (m)	Condition	Azimuth (°)	Height (m)	Raw (dBuV)	AF (dB)	CL (dB)	PA (dB)
AV	2.48G	110.53	Inf	-Inf	31.10	3	Vertical	96	1.04	79.43	27.90	3.20	-
AV	2.4835G	53.92	54.00	-0.08	31.15	3	Vertical	96	1.04	22.77	27.94	3.21	-
PK	2.4796G	112.76	Inf	-Inf	31.10	3	Vertical	96	1.04	81.66	27.90	3.20	-
PK	2.4838G	63.98	74.00	-10.02	31.15	3	Vertical	96	1.04	32.83	27.94	3.21	-

2.4-2.4835GHz_BT-LE(2Mbps)

2480MHz_TX

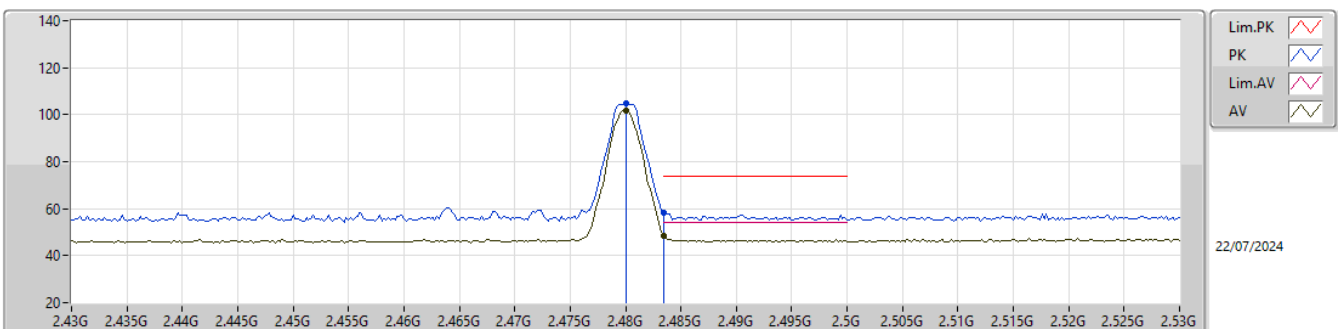

Type	Freq (Hz)	Level (dBuV/m)	Limit (dBuV/m)	Margin (dB)	Factor (dB)	Dist (m)	Condition	Azimuth (°)	Height (m)	Raw (dBuV)	AF (dB)	CL (dB)	PA (dB)
AV	2.48G	101.96	Inf	-Inf	31.10	3	Horizontal	169	1.18	70.86	27.90	3.20	-
AV	2.4835G	48.68	54.00	-5.32	31.15	3	Horizontal	169	1.18	17.53	27.94	3.21	-
PK	2.48G	104.57	Inf	-Inf	31.10	3	Horizontal	169	1.18	73.47	27.90	3.20	-
PK	2.4835G	58.28	74.00	-15.72	31.15	3	Horizontal	169	1.18	27.13	27.94	3.21	-

2.4-2.4835GHz_BT-LE(2Mbps)

2480MHz_TX

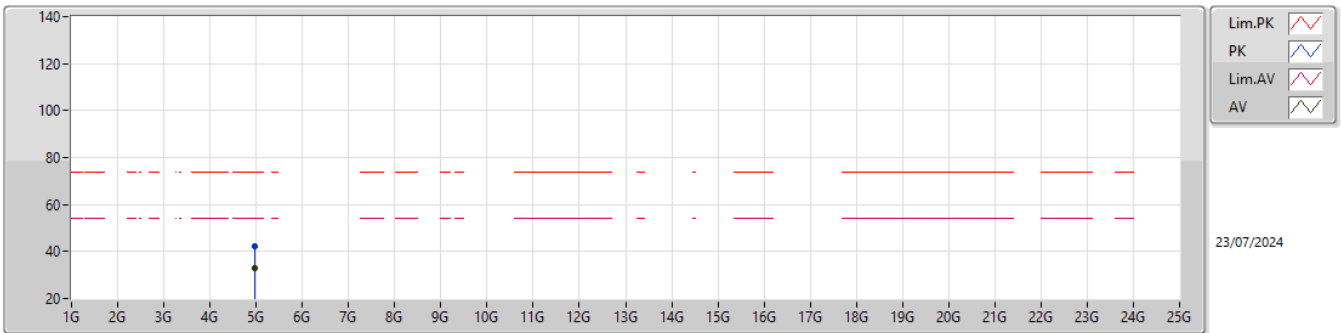

Type	Freq (Hz)	Level (dBuV/m)	Limit (dBuV/m)	Margin (dB)	Factor (dB)	Dist (m)	Condition	Azimuth (°)	Height (m)	Raw (dBuV)	AF (dB)	CL (dB)	PA (dB)
AV	4.95981G	32.77	54.00	-21.23	-6.05	3	Vertical	56	1.48	38.82	33.30	4.70	44.05
PK	4.95908G	42.35	74.00	-31.65	-6.03	3	Vertical	56	1.48	48.38	33.32	4.70	44.05

2.4-2.4835GHz_BT-LE(2Mbps)

2480MHz_TX

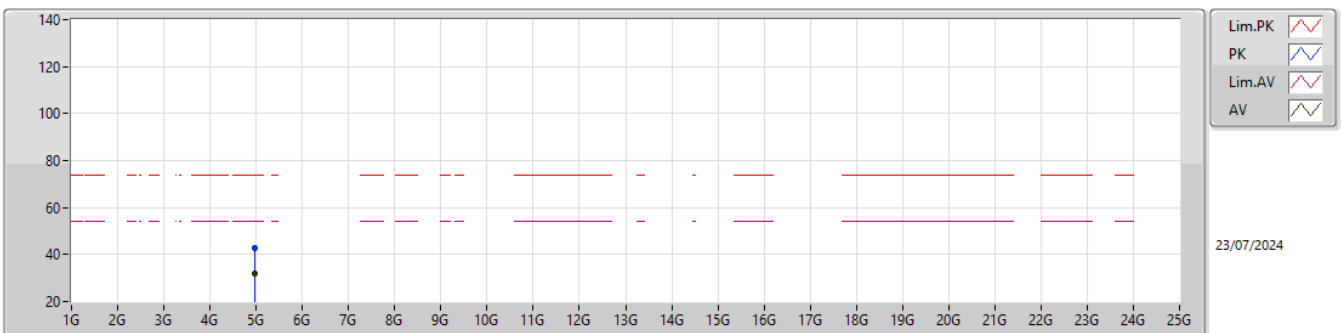

Type	Freq (Hz)	Level (dBuV/m)	Limit (dBuV/m)	Margin (dB)	Factor (dB)	Dist (m)	Condition	Azimuth (°)	Height (m)	Raw (dBuV)	AF (dB)	CL (dB)	PA (dB)
AV	4.96115G	31.69	54.00	-22.31	-6.04	3	Horizontal	227	1.16	37.73	33.31	4.70	44.05
PK	4.96214G	42.60	74.00	-31.40	-6.03	3	Horizontal	227	1.16	48.63	33.32	4.70	44.05



Summary

Mode	Result	Type	Freq (Hz)	Level (dBuV/m)	Limit (dBuV/m)	Margin (dB)	Condition
Mode 1	Pass	AV	20.54466G	50.58	54.00	-3.42	Horizontal
Mode 2	Pass	AV	20.53628G	50.48	54.00	-3.52	Horizontal



Result

Mode	Result	Type	Freq (Hz)	Level (dBuV/m)	Limit (dBuV/m)	Margin (dB)	Dist (m)	Condition	Azimuth (°)	Height (m)
Mode 1	Pass	AV	4.87993G	29.92	54.00	-24.08	3	Vertical	176	1.44
Mode 1	Pass	AV	4.9197G	31.01	54.00	-22.99	3	Vertical	85	1.53
Mode 1	Pass	AV	7.37644G	38.19	54.00	-15.81	3	Vertical	2	1.50
Mode 1	Pass	AV	11.49226G	42.11	54.00	-11.89	3	Vertical	290	1.74
Mode 1	Pass	AV	13.6918G	38.87	68.20	-29.33	3	Vertical	104	1.31
Mode 1	Pass	AV	17.23794G	42.55	68.20	-25.65	3	Vertical	290	1.50
Mode 1	Pass	AV	20.53165G	46.06	54.00	-7.94	3	Vertical	23	1.16
Mode 1	Pass	PK	4.87854G	42.75	74.00	-31.25	3	Vertical	176	1.44
Mode 1	Pass	PK	4.9221G	43.30	74.00	-30.70	3	Vertical	85	1.53
Mode 1	Pass	PK	7.3639G	50.65	74.00	-23.35	3	Vertical	2	1.50
Mode 1	Pass	PK	11.49268G	54.01	74.00	-19.99	3	Vertical	290	1.74
Mode 1	Pass	PK	13.694G	50.10	88.20	-38.10	3	Vertical	104	1.31
Mode 1	Pass	PK	17.22838G	54.45	88.20	-33.75	3	Vertical	290	1.50
Mode 1	Pass	PK	20.53169G	57.65	74.00	-16.35	3	Vertical	314	2.16
Mode 1	Pass	AV	4.8801G	29.90	54.00	-24.10	3	Horizontal	247	1.35
Mode 1	Pass	AV	4.92348G	30.84	54.00	-23.16	3	Horizontal	335	2.71
Mode 1	Pass	AV	7.36614G	45.95	54.00	-8.05	3	Horizontal	295	1.93
Mode 1	Pass	AV	11.4927G	43.70	54.00	-10.30	3	Horizontal	267	2.52
Mode 1	Pass	AV	13.69792G	38.76	68.20	-29.44	3	Horizontal	352	1.00
Mode 1	Pass	AV	17.23356G	48.78	68.20	-19.42	3	Horizontal	318	1.50
Mode 1	Pass	AV	20.54466G	50.58	54.00	-3.42	3	Horizontal	312	1.18
Mode 1	Pass	PK	4.87988G	43.68	74.00	-30.32	3	Horizontal	247	1.35
Mode 1	Pass	PK	4.92174G	42.90	74.00	-31.10	3	Horizontal	335	2.71
Mode 1	Pass	PK	7.36442G	60.63	74.00	-13.37	3	Horizontal	295	1.93
Mode 1	Pass	PK	11.4875G	54.63	74.00	-19.37	3	Horizontal	267	2.52
Mode 1	Pass	PK	13.68982G	49.89	88.20	-38.31	3	Horizontal	352	1.00
Mode 1	Pass	PK	17.23836G	60.41	88.20	-27.79	3	Horizontal	318	1.50
Mode 1	Pass	PK	20.54464G	62.28	74.00	-11.72	3	Horizontal	36	1.53
Mode 2	Pass	AV	4.88G	29.77	54.00	-24.23	3	Vertical	331	2.88
Mode 2	Pass	AV	4.92074G	30.99	54.00	-23.01	3	Vertical	19	1.69
Mode 2	Pass	AV	7.3755G	37.98	54.00	-16.02	3	Vertical	2	1.50
Mode 2	Pass	AV	11.49198G	42.07	54.00	-11.93	3	Vertical	290	1.74
Mode 2	Pass	AV	13.69666G	38.89	68.20	-29.31	3	Vertical	264	1.68
Mode 2	Pass	AV	17.2329G	42.48	68.20	-25.72	3	Vertical	290	1.50
Mode 2	Pass	AV	20.53167G	45.96	54.00	-8.04	3	Vertical	209	1.38
Mode 2	Pass	PK	4.87982G	42.12	74.00	-31.88	3	Vertical	331	2.88
Mode 2	Pass	PK	4.92002G	43.27	74.00	-30.73	3	Vertical	19	1.69
Mode 2	Pass	PK	7.37552G	50.85	74.00	-23.15	3	Vertical	2	1.50
Mode 2	Pass	PK	11.48354G	54.54	74.00	-19.46	3	Vertical	290	1.74
Mode 2	Pass	PK	13.699G	50.72	88.20	-37.48	3	Vertical	264	1.68
Mode 2	Pass	PK	17.2324G	54.28	88.20	-33.92	3	Vertical	290	1.50
Mode 2	Pass	PK	20.53175G	57.59	74.00	-16.41	3	Vertical	174	1.18
Mode 2	Pass	AV	4.88007G	29.82	54.00	-24.18	3	Horizontal	302	1.86
Mode 2	Pass	AV	4.92372G	30.85	54.00	-23.15	3	Horizontal	208	1.38
Mode 2	Pass	AV	7.36496G	46.08	54.00	-7.92	3	Horizontal	295	1.93
Mode 2	Pass	AV	11.49318G	43.90	54.00	-10.10	3	Horizontal	267	2.52
Mode 2	Pass	AV	13.69478G	38.68	68.20	-29.52	3	Horizontal	209	1.24
Mode 2	Pass	AV	17.23354G	49.01	68.20	-19.19	3	Horizontal	318	1.50
Mode 2	Pass	AV	20.53628G	50.48	54.00	-3.52	3	Horizontal	180	1.40
Mode 2	Pass	PK	4.87933G	42.52	74.00	-31.48	3	Horizontal	302	1.86



Mode	Result	Type	Freq (Hz)	Level (dBuV/m)	Limit (dBuV/m)	Margin (dB)	Dist (m)	Condition	Azimuth (°)	Height (m)
Mode 2	Pass	PK	4.92266G	42.87	74.00	-31.13	3	Horizontal	208	1.38
Mode 2	Pass	PK	7.36518G	59.58	74.00	-14.42	3	Horizontal	295	1.93
Mode 2	Pass	PK	11.48754G	54.89	74.00	-19.11	3	Horizontal	267	2.52
Mode 2	Pass	PK	13.69756G	51.14	88.20	-37.06	3	Horizontal	209	1.24
Mode 2	Pass	PK	17.22888G	59.90	88.20	-28.30	3	Horizontal	318	1.50
Mode 2	Pass	PK	20.54471G	62.33	74.00	-11.67	3	Horizontal	306	2.06

Radiated Emissions above 1GHz_Mode 1

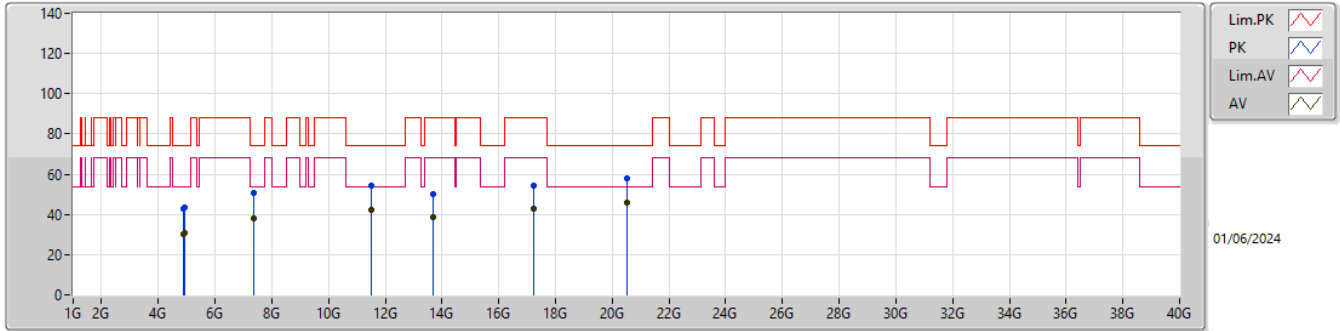

01/06/2024

Type	Freq (Hz)	Level (dBuV/m)	Limit (dBuV/m)	Margin (dB)	Factor (dB/m)	Dist (m)	Condition	Azimuth (°)	Height (m)	Raw (dBuV/m)	AF (dB/m)	CL (dB)	PA (dB)
AV	4.87993G	29.92	54.00	-24.08	-6.50	3	Vertical	176	1.44	36.42	32.92	4.63	44.05
AV	4.9197G	31.01	54.00	-22.99	-6.30	3	Vertical	85	1.53	37.31	33.08	4.66	44.04
AV	7.37644G	38.19	54.00	-15.81	-0.75	3	Vertical	2	1.50	38.94	36.84	6.07	43.66
AV	11.49226G	42.11	54.00	-11.89	5.08	3	Vertical	290	1.74	37.03	39.10	7.78	41.80
AV	13.6918G	38.87	68.20	-29.33	6.18	3	Vertical	104	1.31	32.69	39.92	8.90	42.64
AV	17.23794G	42.55	68.20	-25.65	4.72	3	Vertical	290	1.50	37.83	37.58	10.40	43.26
AV	20.53165G	46.06	54.00	-7.94	-24.09	3	Vertical	23	1.16	70.15	38.10	11.21	63.86
PK	4.87854G	42.75	74.00	-31.25	-6.51	3	Vertical	176	1.44	49.26	32.91	4.63	44.05
PK	4.9221G	43.30	74.00	-30.70	-6.29	3	Vertical	85	1.53	49.59	33.09	4.66	44.04
PK	7.3639G	50.65	74.00	-23.35	-0.70	3	Vertical	2	1.50	51.35	36.92	6.05	43.67
PK	11.49268G	54.01	74.00	-19.99	5.08	3	Vertical	290	1.74	48.93	39.10	7.78	41.80
PK	13.694G	50.10	88.20	-38.10	6.16	3	Vertical	104	1.31	43.94	39.91	8.90	42.65
PK	17.22838G	54.45	88.20	-33.75	4.69	3	Vertical	290	1.50	49.76	37.56	10.39	43.26
PK	20.53169G	57.65	74.00	-16.35	-24.09	3	Vertical	314	2.16	81.74	38.10	11.21	63.86

Radiated Emissions above 1GHz_Mode 1

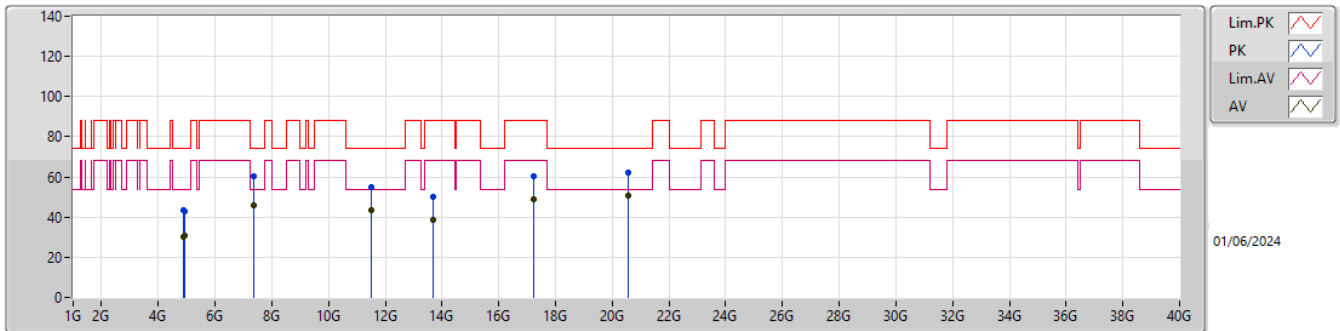

01/06/2024

Type	Freq (Hz)	Level (dBuV/m)	Limit (dBuV/m)	Margin (dB)	Factor (dB/m)	Dist (m)	Condition	Azimuth (°)	Height (m)	Raw (dBuV/m)	AF (dB/m)	CL (dB)	PA (dB)
AV	4.8801G	29.90	54.00	-24.10	-6.50	3	Horizontal	247	1.35	36.40	32.92	4.63	44.05
AV	4.92348G	30.84	54.00	-23.16	-6.29	3	Horizontal	335	2.71	37.13	33.09	4.66	44.04
AV	7.36614G	45.95	54.00	-8.05	-0.71	3	Horizontal	295	1.93	46.66	36.90	6.06	43.67
AV	11.4927G	43.70	54.00	-10.30	5.08	3	Horizontal	267	2.52	38.62	39.10	7.78	41.80
AV	13.69792G	38.76	68.20	-29.44	6.16	3	Horizontal	352	1.00	32.60	39.90	8.91	42.65
AV	17.23356G	48.78	68.20	-19.42	4.70	3	Horizontal	318	1.50	44.08	37.57	10.39	43.26
AV	20.54466G	50.58	54.00	-3.42	-24.08	3	Horizontal	312	1.18	74.66	38.10	11.21	63.85
PK	4.87988G	43.68	74.00	-30.32	-6.50	3	Horizontal	247	1.35	50.18	32.92	4.63	44.05
PK	4.92174G	42.90	74.00	-31.10	-6.29	3	Horizontal	335	2.71	49.19	33.09	4.66	44.04
PK	7.36442G	60.63	74.00	-13.37	-0.71	3	Horizontal	295	1.93	61.34	36.91	6.05	43.67
PK	11.4875G	54.63	74.00	-19.37	5.07	3	Horizontal	267	2.52	49.56	39.10	7.77	41.80
PK	13.68982G	49.89	88.20	-38.31	6.18	3	Horizontal	352	1.00	43.71	39.92	8.90	42.64
PK	17.23836G	60.41	88.20	-27.79	4.72	3	Horizontal	318	1.50	55.69	37.58	10.40	43.26
PK	20.54464G	62.28	74.00	-11.72	-24.08	3	Horizontal	36	1.53	86.36	38.10	11.21	63.85

Radiated Emissions above 1GHz_Mode 2

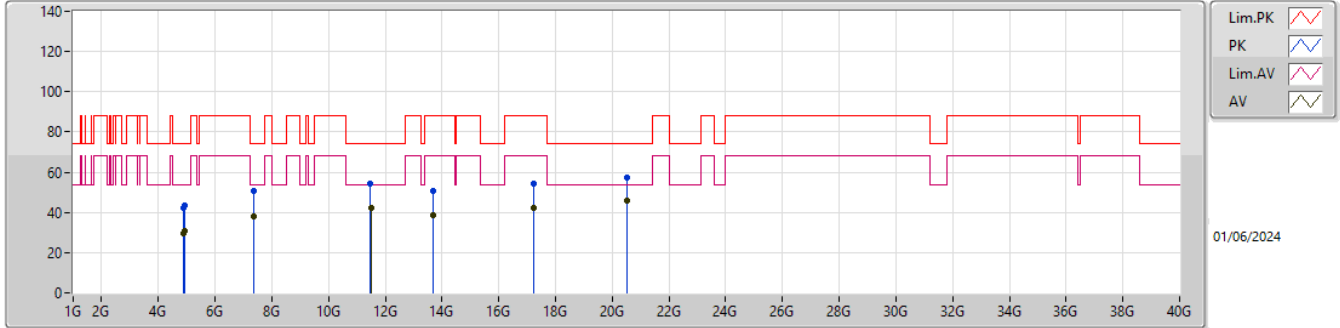

Type	Freq (Hz)	Level (dBuV/m)	Limit (dBuV/m)	Margin (dB)	Factor (dB/m)	Dist (m)	Condition	Azimuth (°)	Height (m)	Raw (dBuV/m)	AF (dB/m)	CL (dB)	PA (dB)
AV	4.88G	29.77	54.00	-24.23	-6.50	3	Vertical	331	2.88	36.27	32.92	4.63	44.05
AV	4.92074G	30.99	54.00	-23.01	-6.30	3	Vertical	19	1.69	37.29	33.08	4.66	44.04
AV	7.3755G	37.98	54.00	-16.02	-0.74	3	Vertical	2	1.50	38.72	36.85	6.07	43.66
AV	11.49198G	42.07	54.00	-11.93	5.08	3	Vertical	290	1.74	36.99	39.10	7.78	41.80
AV	13.69666G	38.89	68.20	-29.31	6.17	3	Vertical	264	1.68	32.72	39.91	8.91	42.65
AV	17.2329G	42.48	68.20	-25.72	4.70	3	Vertical	290	1.50	37.78	37.57	10.39	43.26
AV	20.53167G	45.96	54.00	-8.04	-24.09	3	Vertical	209	1.38	70.05	38.10	11.21	63.86
PK	4.87982G	42.12	74.00	-31.88	-6.50	3	Vertical	331	2.88	48.62	32.92	4.63	44.05
PK	4.92002G	43.27	74.00	-30.73	-6.30	3	Vertical	19	1.69	49.57	33.08	4.66	44.04
PK	7.37552G	50.85	74.00	-23.15	-0.74	3	Vertical	2	1.50	51.59	36.85	6.07	43.66
PK	11.48354G	54.54	74.00	-19.46	5.06	3	Vertical	290	1.74	49.48	39.10	7.77	41.81
PK	13.699G	50.72	88.20	-37.48	6.16	3	Vertical	264	1.68	44.56	39.90	8.91	42.65
PK	17.2324G	54.28	88.20	-33.92	4.69	3	Vertical	290	1.50	49.59	37.56	10.39	43.26
PK	20.53175G	57.59	74.00	-16.41	-24.09	3	Vertical	174	1.18	81.68	38.10	11.21	63.86

Radiated Emissions above 1GHz_Mode 2

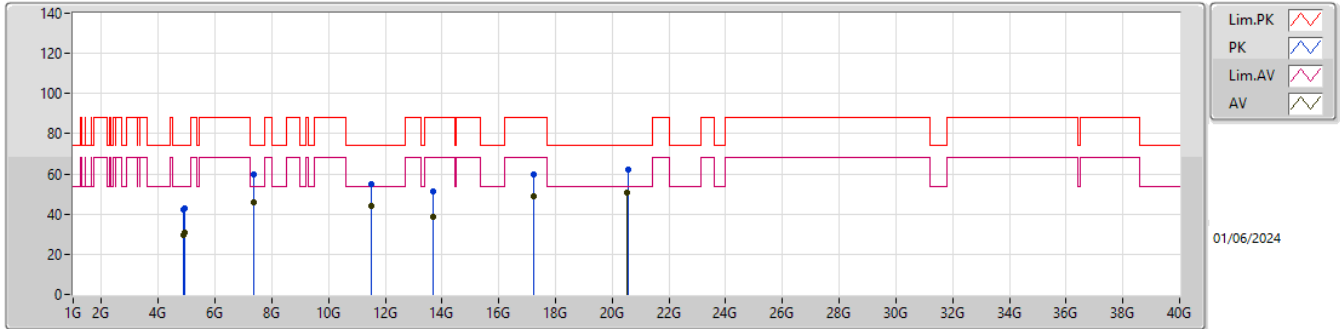

Type	Freq (Hz)	Level (dBuV/m)	Limit (dBuV/m)	Margin (dB)	Factor (dB/m)	Dist (m)	Condition	Azimuth (°)	Height (m)	Raw (dBuV/m)	AF (dB/m)	CL (dB)	PA (dB)
AV	4.88007G	29.82	54.00	-24.18	-6.50	3	Horizontal	302	1.86	36.32	32.92	4.63	44.05
AV	4.92372G	30.85	54.00	-23.15	-6.28	3	Horizontal	208	1.38	37.13	33.09	4.67	44.04
AV	7.36496G	46.08	54.00	-7.92	-0.71	3	Horizontal	295	1.93	46.79	36.91	6.05	43.67
AV	11.49318G	43.90	54.00	-10.10	5.08	3	Horizontal	267	2.52	38.82	39.10	7.78	41.80
AV	13.69478G	38.68	68.20	-29.52	6.17	3	Horizontal	209	1.24	32.51	39.91	8.91	42.65
AV	17.23354G	49.01	68.20	-19.19	4.70	3	Horizontal	318	1.50	44.31	37.57	10.39	43.26
AV	20.53628G	50.48	54.00	-3.52	-24.09	3	Horizontal	180	1.40	74.57	38.10	11.21	63.86
PK	4.87933G	42.52	74.00	-31.48	-6.50	3	Horizontal	302	1.86	49.02	32.92	4.63	44.05
PK	4.92266G	42.87	74.00	-31.13	-6.29	3	Horizontal	208	1.38	49.16	33.09	4.66	44.04
PK	7.36518G	59.58	74.00	-14.42	-0.71	3	Horizontal	295	1.93	60.29	36.91	6.05	43.67
PK	11.48754G	54.89	74.00	-19.11	5.07	3	Horizontal	267	2.52	49.82	39.10	7.77	41.80
PK	13.69756G	51.14	88.20	-37.06	6.16	3	Horizontal	209	1.24	44.98	39.90	8.91	42.65
PK	17.22888G	59.90	88.20	-28.30	4.69	3	Horizontal	318	1.50	55.21	37.56	10.39	43.26
PK	20.54471G	62.33	74.00	-11.67	-24.08	3	Horizontal	306	2.06	86.41	38.10	11.21	63.85