

Airgain™



Coverage.

Performance.

Smart.

**Profile Series
N04TCAFD**

**Airgain
Embedded
Antenna**

**Engineering
Data Sheet**

3611 Valley Centre Drive, Suite 150
San Diego, CA 92130 USA
Tel: +1 760 579 0200
Fax: +1 760 579 0892
Information: info@airgain.com
Sales: sales@airgain.com
Support: support@airgain.com

Revision History (Required)

Revision	Date	Note
3321-02-00-001-1 Rev 1.0	April 13, 2021	Preliminary Datasheet 1.0
3321-02-00-001-1 Rev 1.1	August 9,2021	Added peak gain and Radiation Patterns
3321-02-00-001-1 Rev 1.2	November 22,2022	Modify according to customer requirements

Contents

1. Airgain N04TCAFD Embedded Antenna	4
2. Features.....	4
3. Specifications and Interface.....	5
4. Radiation Patterns.....	5
5. Dimensions	8
6. ROHS.....	8
7. Feature and Options Information.....	8
7.1 Part Number Conventions	9
7.2 Part Number Example	9
8. Cable Data Sheet	10

Figures

Figure 1: Model N04TCAFD Embedded Antenna.....	4
Figure 2: Model N04TCAFD Measurement axes	5
Figure 3: Model N04TCAFD Radiation Patterns at 2.44 GHz	6
Figure 4: Model N04TCAFD Radiation Patterns at 6.525 GHz	7
Figure 5: Model N04TCAFD Pre-applied Tape Dimensions	8
Figure 6: N04TCAFD with connector or stripped cable.....	9

1. Airgain N04TCAFD Embedded Antenna

The Model N04TCAFD Embedded Antenna provides a high efficiency, dual band embedded antenna solution for Wi-Fi and ISM band applications, such as WLAN products. As embedded antenna solutions become the focus of next generation wireless product design, the Model N04TCAFD provides the flexibility of an embedded antenna with top performance. The Model N04TCAFD Embedded Antenna is a center fed version of its predecessor, the N04TCAFD, allowing it to fit in spaces where center feeding is better suited. It is designed to accommodate most WLAN access point applications, such as routers and gateways and can be easily integrated into an ID package design.

2. Features

The Airgain N04TCAFD embedded antenna includes the following features:

- IEEE 802.11 a/b/g/n/ac standards
- Case mount
- High efficiency
- Quick integration

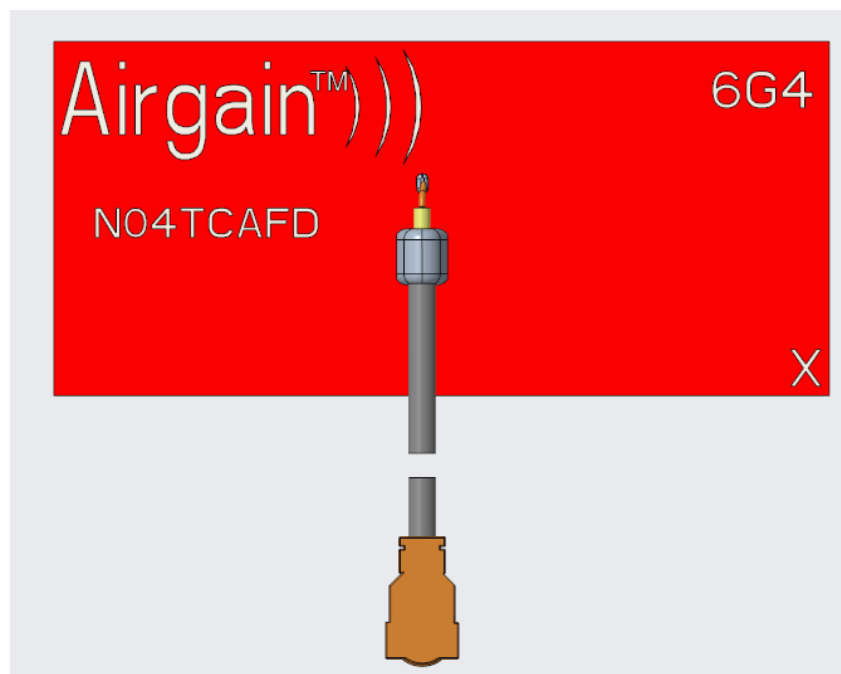

Figure 1: Model N04TCAFD Embedded Antenna

3. Specifications and Interface

Standard	IEEE 802.11 a/b/g/n/ac
Frequency range	2400-2490 MHz & 5925-7125 MHz
Peak gain	4.8 dBi @2.44 GHz, 5.5 dBi @ 5925-7125 MHz
VSWR	< 2:1
Feed impedance	50 ohms
Power handling	30 dBm
Interface	50 ohms, 1.13 mm diameter, micro coax cable (available with optional U.FL-compatible cable connector and/or cable-mounted EMI ferrites)
Antenna dimensions	31.8 x 14.5 x 0.5 mm
Weight	1.05 g
Temperature range	Operating: -40° C to +75° C (-40° F to +167° F) Storage: -40° C to +85° C (-40° F to +185° F)
Humidity range	0% to 95% non-condensing

4. Radiation Patterns

Antenna attached to 90mm x 90mm 3mm-thick ABS plastic with 0.5mm tape.

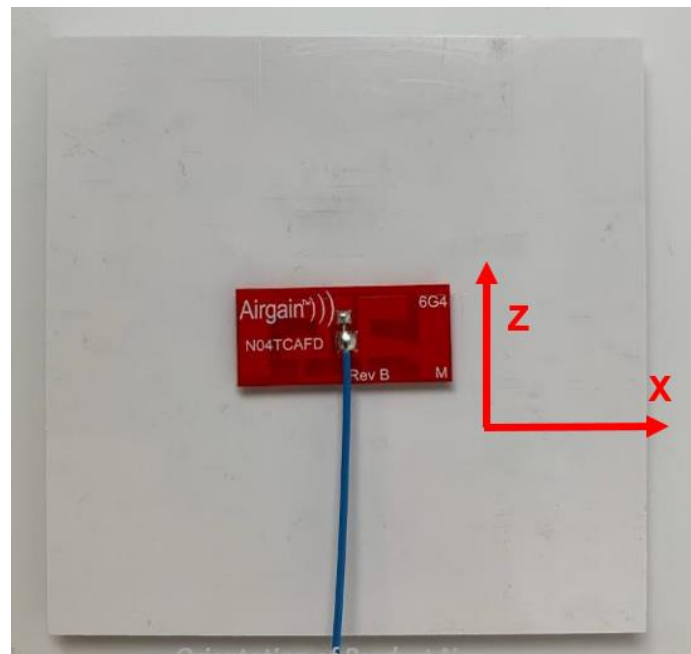

Figure 2: Model N04TCAFD Measurement axes

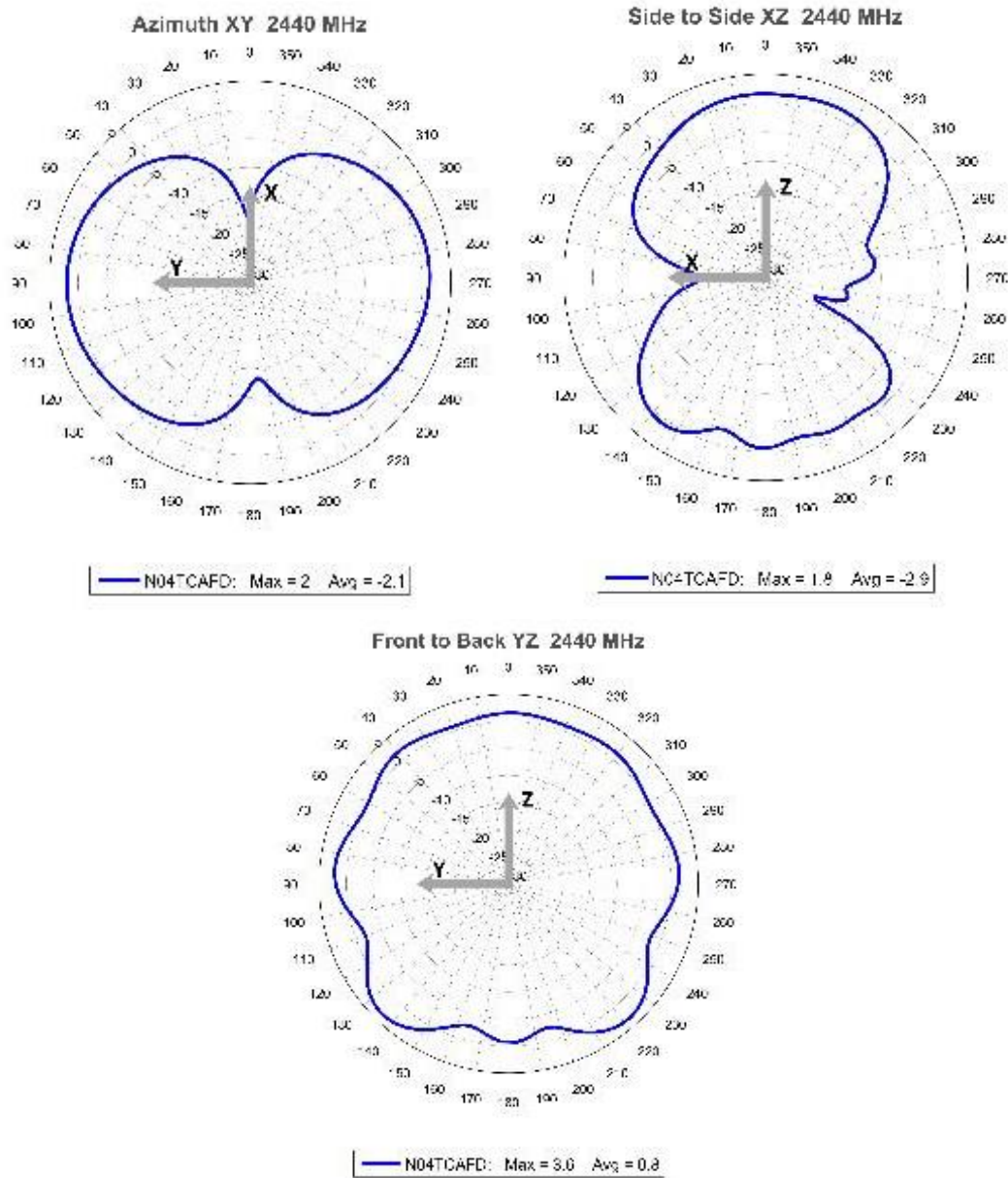

Figure 3: Model N04TCAFD Radiation Patterns at 2.44 GHz

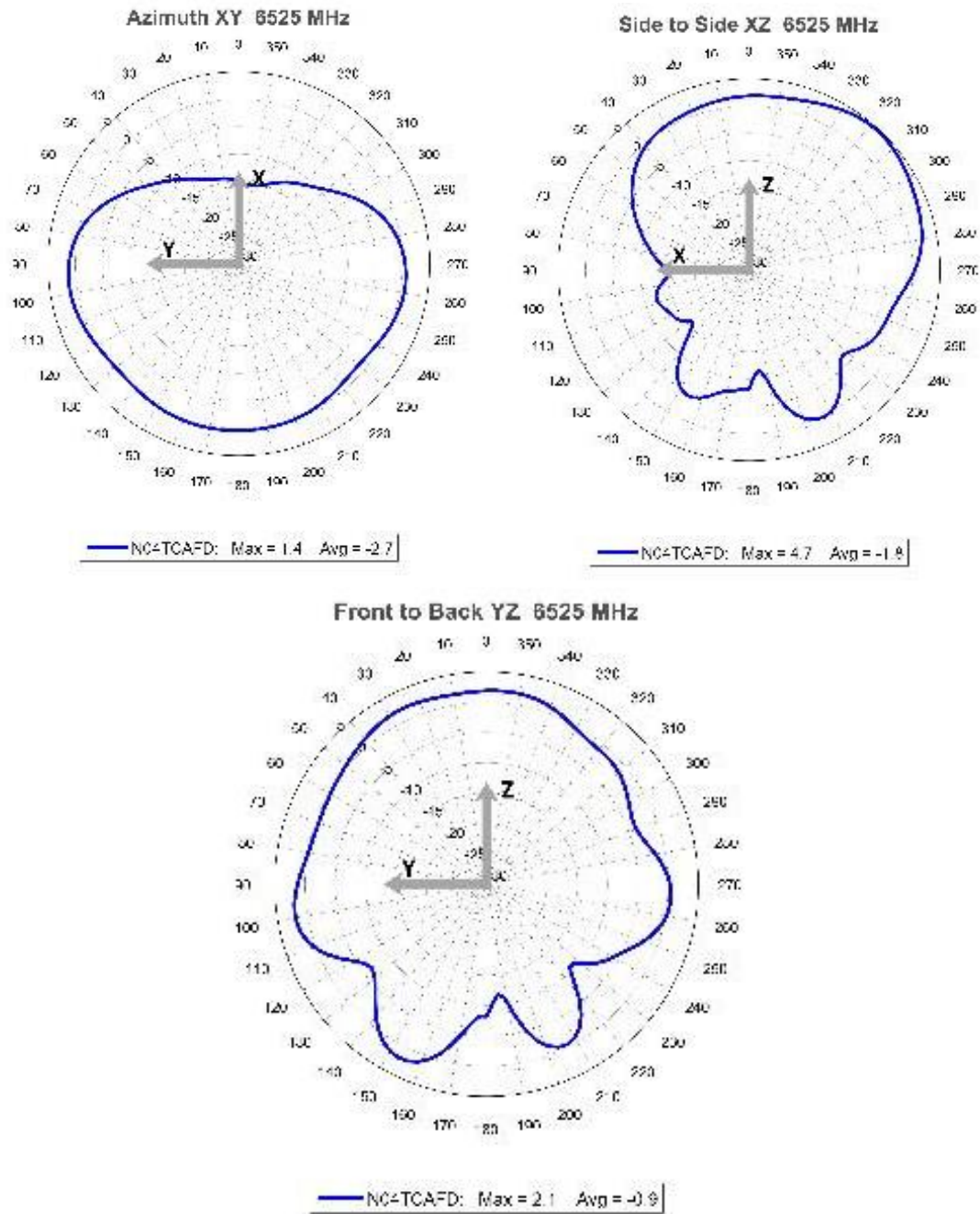

Figure 4: Model N04TCAFD Radiation Patterns at 6.525 GHz

5. Dimensions

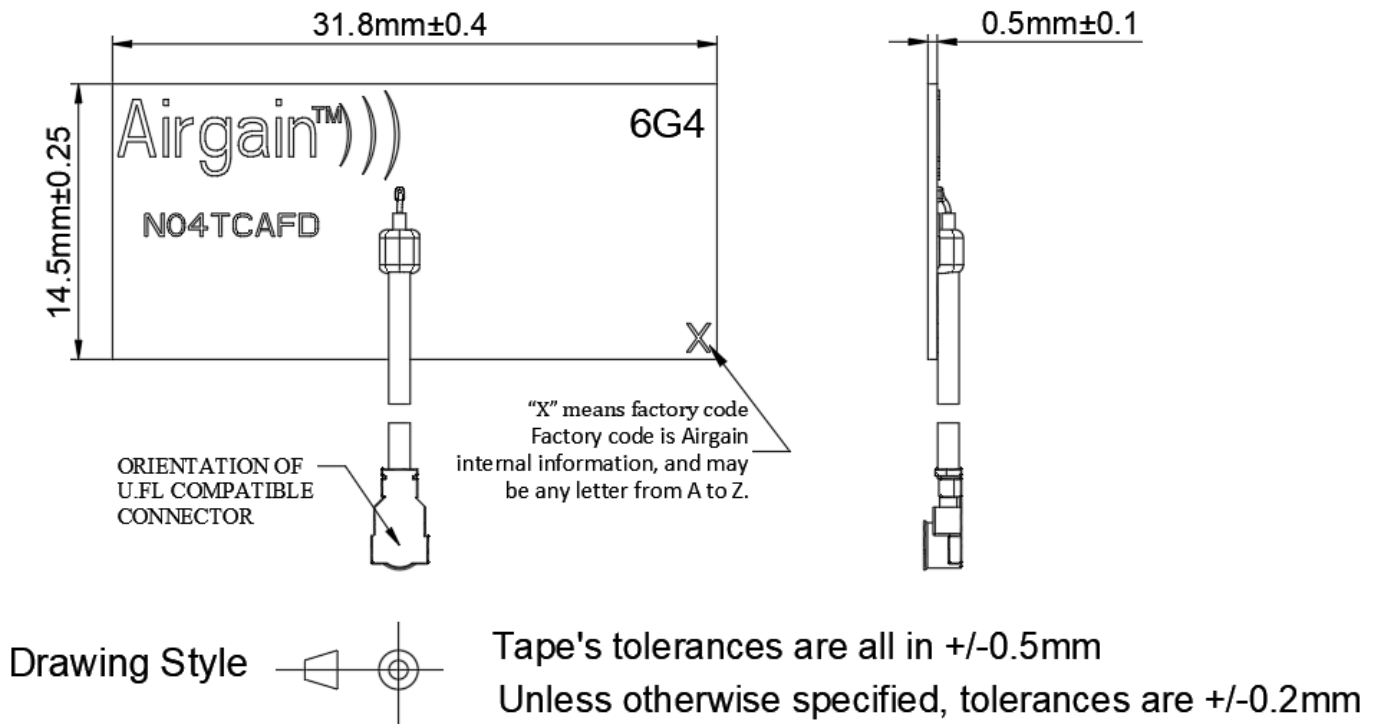

Figure 5: Model N04TCAFD Pre-applied Tape Dimensions

6. ROHS

Airgain N04TCAFD embedded antennas are RoHS compliant.

7. Feature and Options Information

Airgain N04TCAFD antennas are equipped with an RF cable I/O interface. Optional cable termination such as U.FL-compatible micro coax connectors and cable mounted EMI ferrite cores are available. To aid mounting the N04TCAFD, pre-applied, double-sided adhesive tape is available on the N04TCAFD -T Series.

7.1 Part Number Conventions

Airgain uses a three-staged standard number system for our part numbers, which serially define the antenna type, tape type, cable type/length, and connector type/interface, as described below:

Antenna #	Tape type -XX (if required)	Packaging type -xx	Cable Assembly Type -xxxxxx		
			Cable Color -x	Cable length XXX	Connector type XX (if required)
N04TCAFD	Blank = No Tape T = Tape on bottom of element T64 = 6.4mm EVA Tape affixed to the surface of antenna	PK1= singulated (individual) antennas (PK1 is mandatory)	G = Grey (Standard) B = Black (Non Standard) W = White (Non Standard) A = Blue(Non Standard) LB = 1.13mmOD, Low loss Black Cable	Cable length in millimeters (mm) Sample Lengths*: 65, 100, 130, 150, 190, 230, 250, 300,400	Blank = Stripped Cable U = U.FL connector C = U.FL connector plus Ferrite Core, core size: 3.5mm * 9.0mm * 1.5mm CFCxx = Optional core location, Red phosphorus free, (xx)mm distance from the edge of the Core and U.FL compatible connector, xx = length in mm UR2 = U.FL compatible connector, rotated 180°

* Standard cable lengths listed in RF Cable Datasheet

7.2 Part Number Example

N04TCAFD-T-PK1-G100U – N04TCAFD antenna with 1.6-mm double-sided adhesive tape, 100-mm cable, and U.FL-compatible connector.

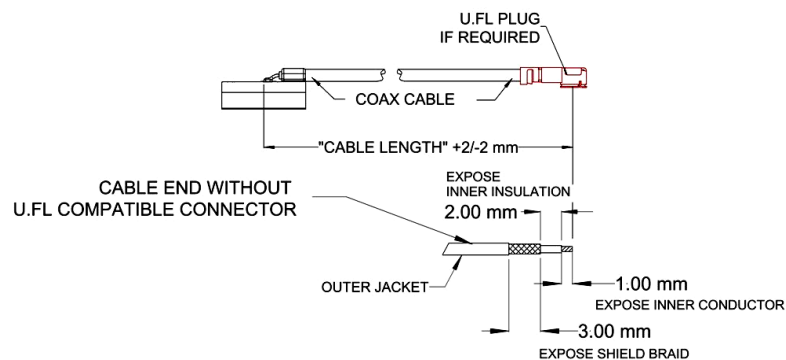
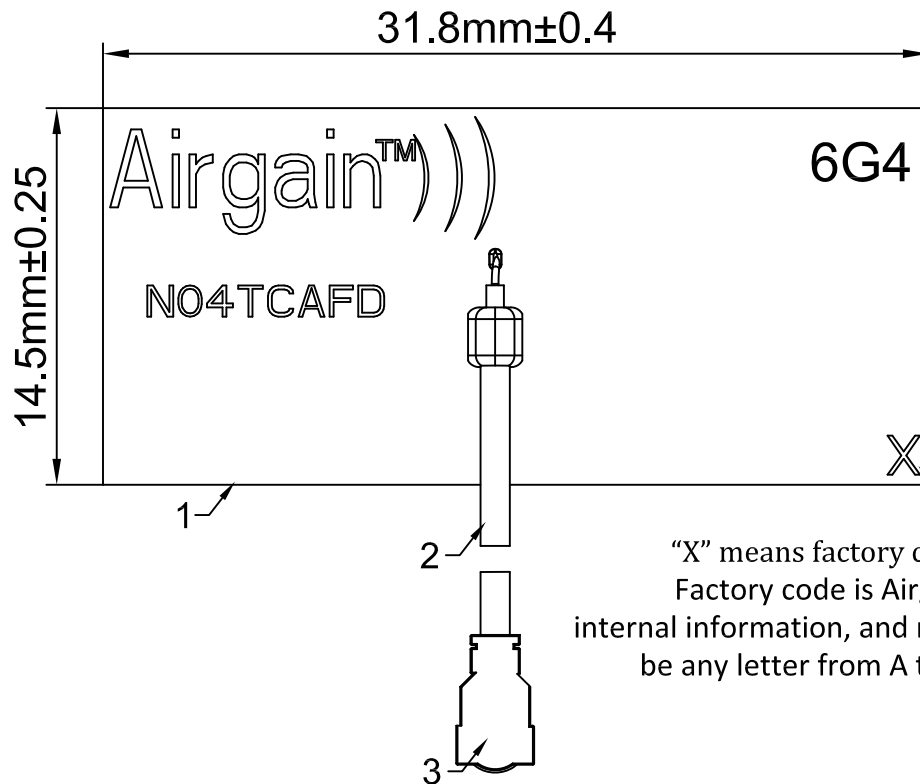

Figure 6: N04TCAFD with connector or stripped cable

8. Cable Data Sheet

Item	Specification	
Cable type	OD1.13	
Impedance	50 ± 3 ohms	
Inner conductor	Material	Tin-coated copper
	Conductor numbers	7
	Conductor size	0.08 mm
	Outer diameter	0.24 ± 0.02 mm
Dielectric layer	Material	FEP
	Color	Clear
	Average thickness	0.22 mm
	Diameter	0.7 ± 0.03 mm
Braid (shielding)	Material	Tin-coated copper
	Conductor size :total / O.D. of every wire(mm)	16*4/0.05 mm
	Coverage	90%± 5%
	Diameter	0.92 ± 0.05 mm
Outer cover	Material	FEP
	Color	Black / white / grey / blue
	Average thickness	0.10 mm
	Diameter	1.13 ± 0.05 mm
VSWR testing	< 1.3@0~6GHz	
Attenuation (dB/1meter)	1GHz	≤2.2
	2GHz	≤3.1
	3GHz	≤3.8
	4GHz	≤4.4
	5GHz	≤4.9
	6GHz	≤5.4
Operating temperature	-55°C~+150°C	

REV	DESCRIPTION	BY	DATE
A	Initial Design	BWU	15/APR/2021



"X" means factory code
Factory code is Airgain
internal information, and may
be any letter from A to Z.

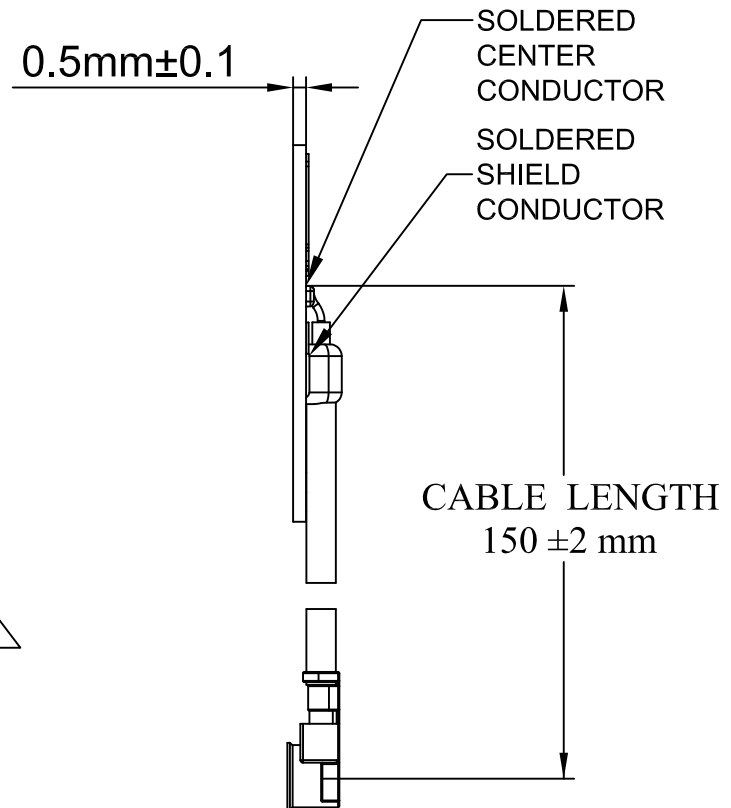

Notes:

- The processes used to assemble this antenna shall comply with the following specifications ,unless otherwise specified.
- 1.Solder:use lead free solder if applies for lead free soldering process to assemble the antenna , unless otherwise specified.
 - 2.Bom:use the bom file for assembling the antenna.this table is provided for reference only.
 - 3.Unless otherwise specified dimension, tolerances are +/-0.2mm
 - 4.Packaging type: break up panel packaging

ITEM#	DESIGNATOR	QUANTITY	NOTE
1	Antenna	1	
2	Coax Cable	1	1.13mm OD, Blue RF Cable
3	Connector	1	Connector for 1.13mm cable

DRAWING STYLE

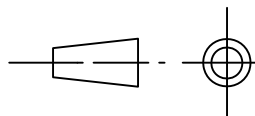

BOM No. 3321-06-00-001-1	3611 Valley Centre Drive, Suite 150 San Diego, CA 92130 USA		Airgain™	
PCB No. 3321-12-00-001-1	Project	PROFILE EMBEDDED ANTENNA		
Drawn by BWU	Date 22/APR/2021	Title	N04TCAFD-PK1-A150U	
Checked by	Date	Size B	Number 3321-07-00-001-3	Rev. A
Approved by	Date	Layer	Scale	
		File	Sheet 1 of 1	