



CAUTION-ELECTRICALLY OPERATED PRODUCT:
NOT RECOMMENDED FOR CHILDREN UNDER 8 YEARS OF AGE.
AS WITH ALL ELECTRIC PRODUCTS, PRECAUTIONS SHOULD BE
OBSERVED DURING HANDLING AND USE TO PREVENT ELECTRIC
SHOCK. INPUT: 120V AC 60Hz 6.5W. OUTPUT: 11.6V DC 165mA.

9.6V NiCd **Radio Control**
RECHARGEABLE **Vehicle**

OWNERS MANUAL

Please read and understand all precautions prior to use.

Thank you for choosing a premium New Bright product.

We're here to help!

Call us toll free at **1-866-697-2869**

8:00 am - 5:00 pm E.S.T. Mon.- Fri.

Or visit us on line at www.newbright.com

Do not return this toy to the store!

We stand behind our product. If you experience any difficulty assembling, charging or operating this toy, please call us and let us help.

Table of Contents

- Page 1: Table of Contents**
- Page 2: Component Checklist**
- Page 3: Charging the Battery**
- Page 4: Battery Installation in Vehicle**
- Page 5: Vehicle Features and Functions**
- Page 6: Antenna Placement
Transmitter Battery Installation**
- Page 7: Transmitter Features and Functions**
- Page 8: Setting the Band**
- Page 9: Proper Use
Precautions and Care**
- Page 10: Trouble Shooting and Support**
- Page 11: Caution**

New Bright

Component Checklist

To protect components from damage, they may be packed in the styrofoam tray out of plain sight. Please search styrofoam tray and remove all of the components shown below. Styrofoam should be saved for storing your vehicle.

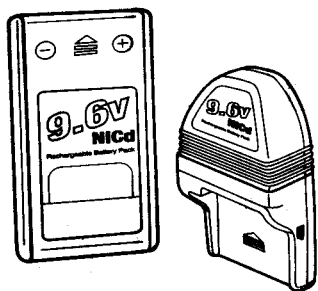

1

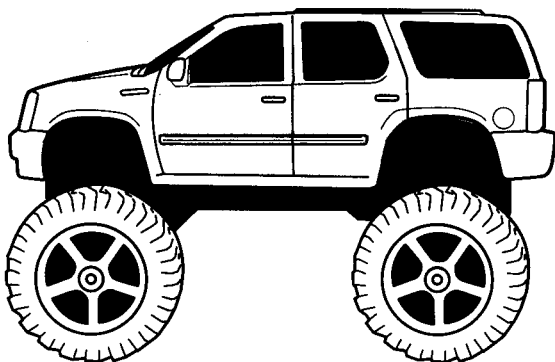

1

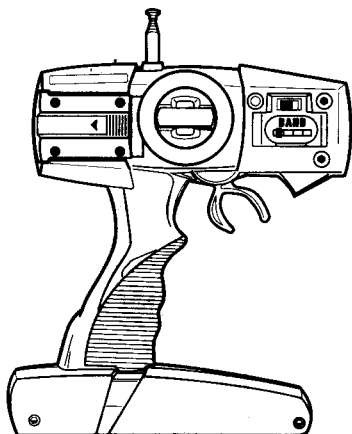

1



2

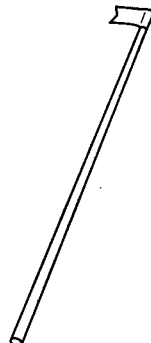

1

Battery Pack

Charging the Battery

IMPORTANT!

The included 9.6V NiCd battery pack is NOT charged prior to shipment and must be charged at least 8 hours before the first use.

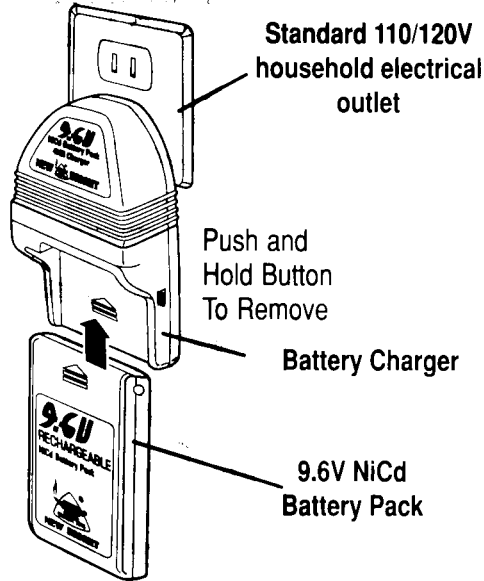

1. Plug the Charger into a standard 110/120V indoor electrical outlet.
2. Insert the 9.6V NiCd rechargeable battery pack securely into the charging cradle (as shown above). Be sure the arrows are properly matched.
3. Allow battery to charge for a minimum of 8 hours on the initial two charges. Subsequent charges require only 4 hours.
4. Charge will last approximately 15 minutes depending on terrain and driving style.
5. This power unit is intended to be correctly orientated in a vertical or floor mount position.

IMPORTANT: It is normal for the battery pack to become warm after charging and/or use. Be sure to allow the battery pack to cool before using or recharging. Recharging a warm battery pack will greatly reduce the battery life.

Battery pack can be charged up to 1,000 times!

ATTENTION PARENTS:

- The Battery Charger & Battery Pack need to be periodically examined for potential hazards. Any potentially hazardous parts need to be repaired or replaced.

Vehicle

Battery Installation

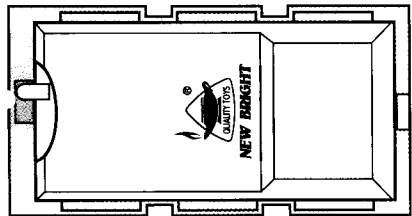
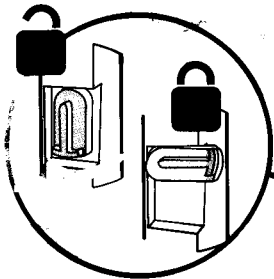
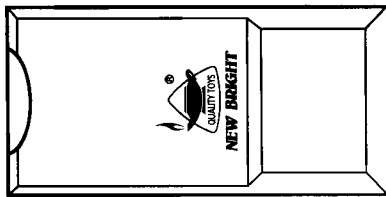
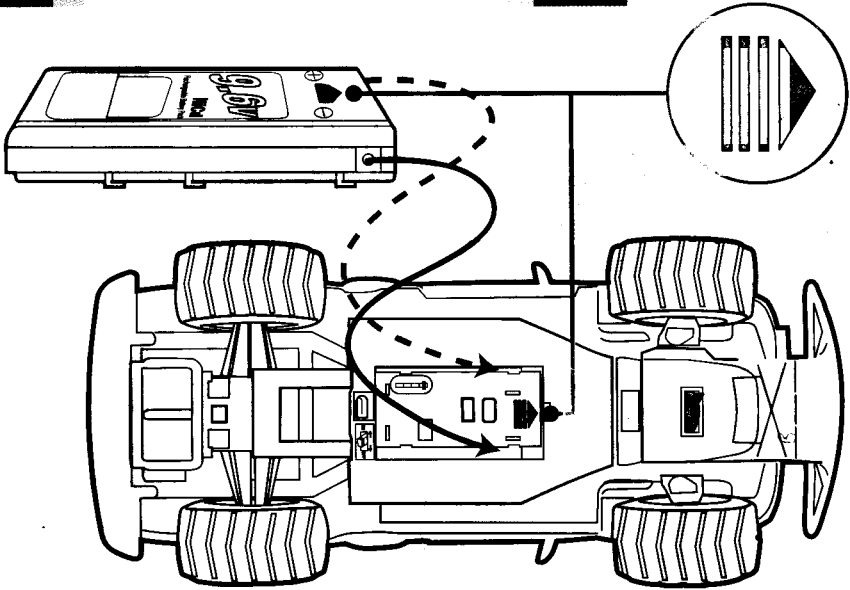

Vehicle

Features and Functions



ON/OFF Switch

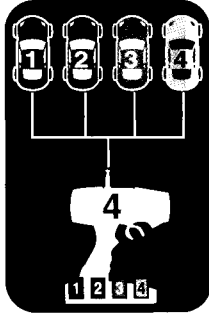

4 Band Select

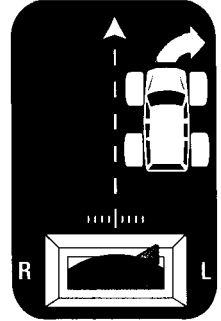
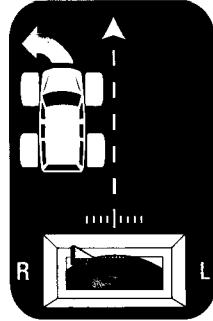

Steering Trim*

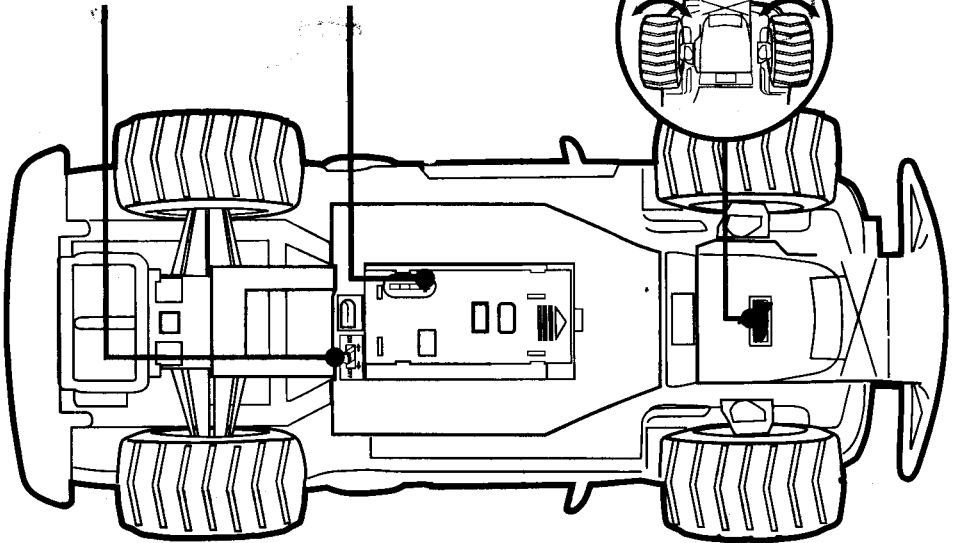

* If vehicle pulls to the left or right during forward driving the Steering Trim may need to be adjusted. The Steering Trim is located on bottom of chassis between the front wheels.

Antenna

Antenna Placement

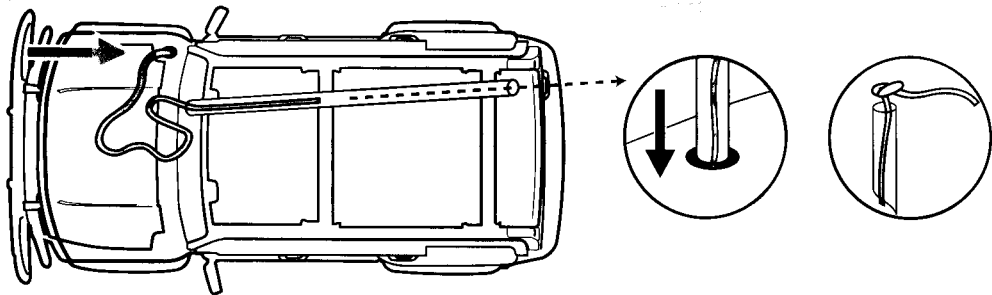

Transmitter

Battery Installation

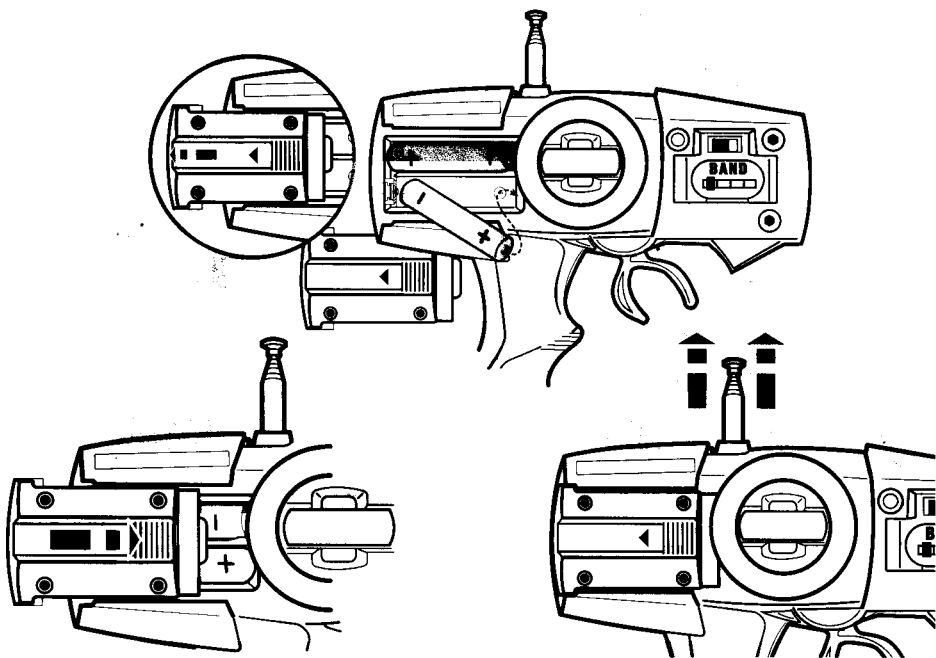

Note: When replacing Transmitter batteries: Do not mix old and new batteries.
Do not mix alkaline, standard or rechargeable batteries. Use alkaline batteries only.

Transmitter

Features and Functions

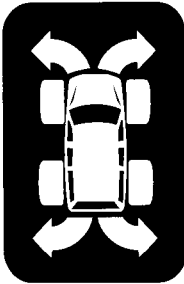

Left/Right Steering

ON/OFF Switch

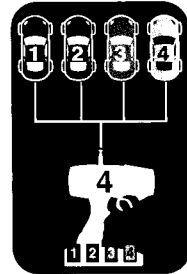

4 Band Select

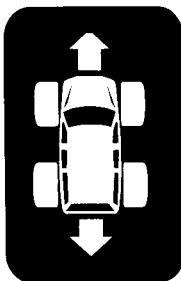
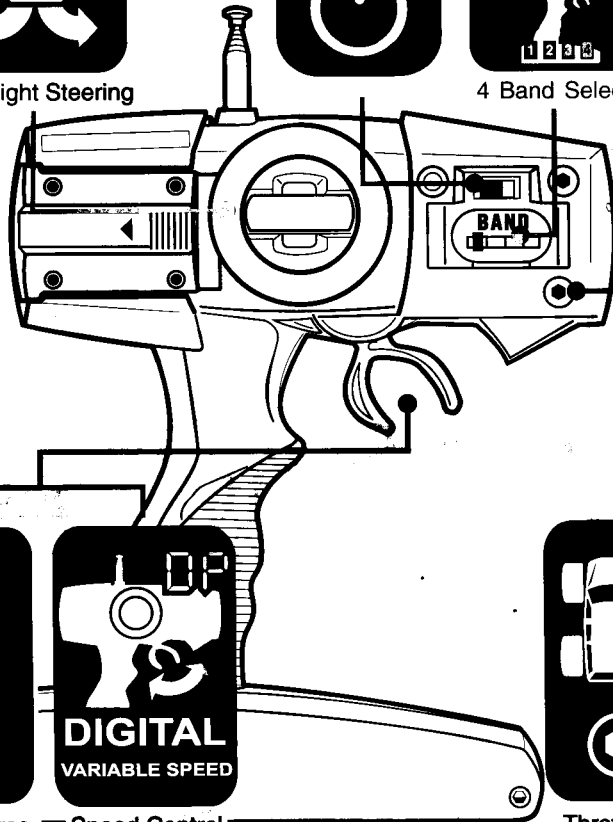

Forward/Reverse



DIGITAL
VARIABLE SPEED

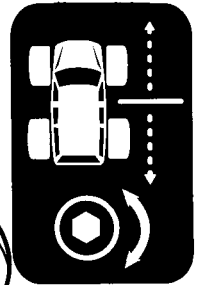

Throttle Trim*

- * Turn the vehicle upside down and locate the vehicle power switch on the bottom of the chassis. Move power switch to the "On" position. If the wheels move, Throttle Trim may need to be adjusted. Turn dial on transmitter until wheels come to a stop.

FCC CAUTION:

The manufacturer is not responsible for radio interference caused by unauthorized frequency modification to this equipment. Such modifications could void the user's authority to operate the equipment.

Settings

Setting the Band

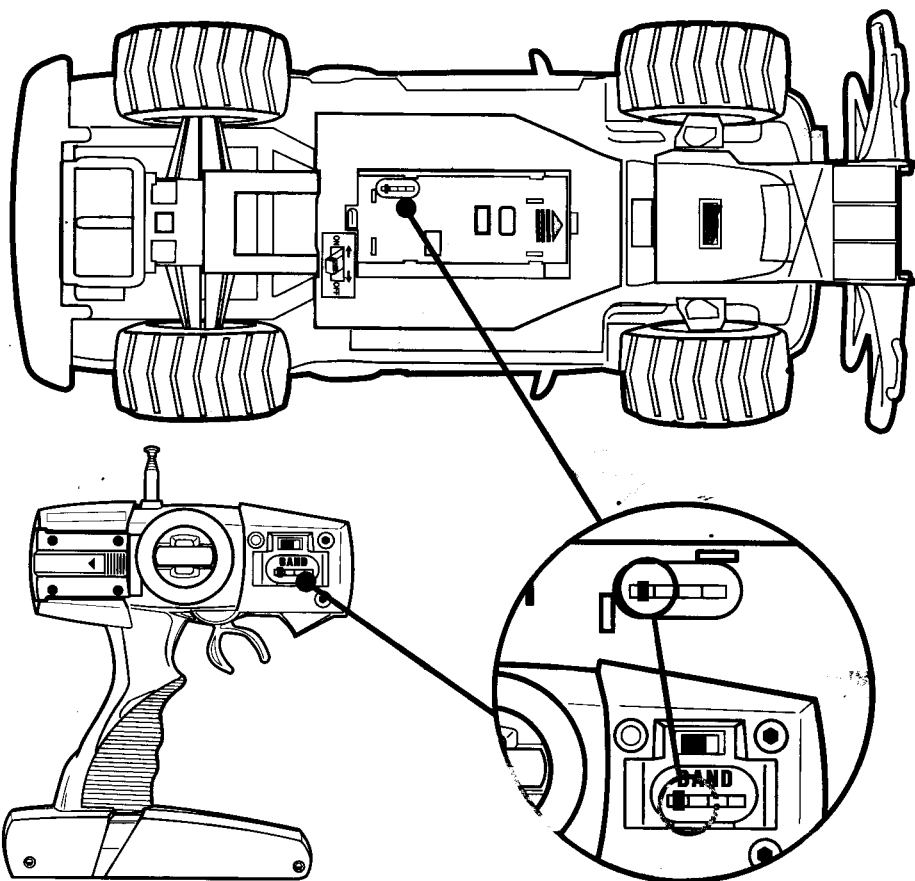
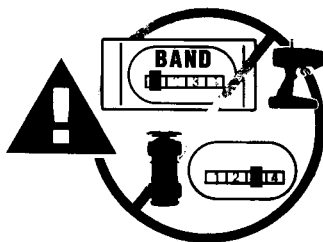
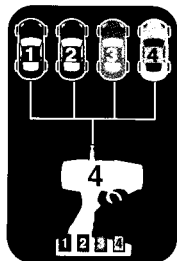

IMPORTANT: Make certain the vehicle's 4 Band Select switch matches the setting of the 4 Band Select Switch on the transmitter.

Proper Use

Precautions and Care

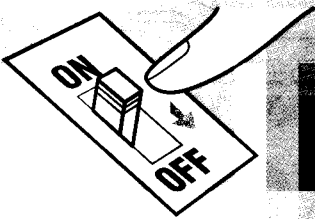
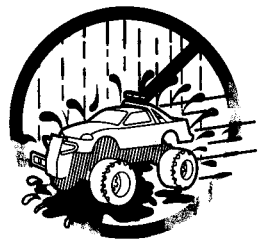
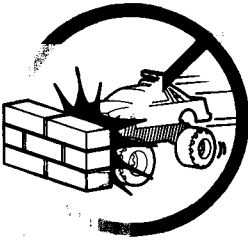
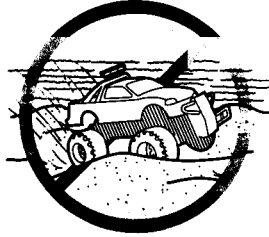

Switch vehicle OFF
when not in use.

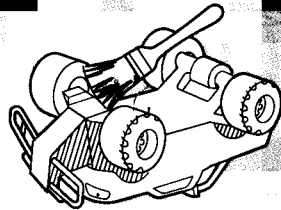

Brush areas where
dirt gets trapped.



Wipe body with a
soft rag or taut cloth.

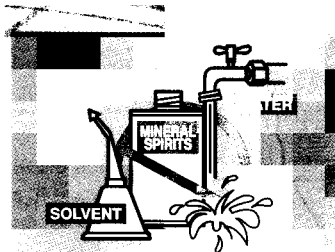

Do not use chemicals
or water to clean

Support

Trouble Shooting & Support

Problem - Vehicle does not move or moves slowly.

- Make certain there are fresh alkaline batteries in the transmitter and that they have been installed in the correct position.
- Are the (+) and (-) markings on the alkaline batteries in the same position as the (+) and (-) markings in the Transmitter Battery Compartment?
- Has the Battery Pack been installed in the vehicle?
- Has the rechargeable Battery Pack been fully charged?
- Are the (+) and (-) markings on the Battery Pack in the same position as the (+) and (-) markings in the Battery Compartment?
- Are the metal contact tabs touching, rusty or dirty in the transmitter?
- Make certain that the vehicle ON/OFF switch is in the "ON" position.
- Make certain the vehicle's 4 Band Select Switch matches the setting of the 4 Band Select Switch on the Transmitter.
- Make certain that the transmitter antenna is fully extended.

Problem - Vehicle moves by itself or exhibits reduced range from the transmitter.

- Make certain there is no outside radio interference in your area. The best way to test this is to take the vehicle as far away from radio towers, electrical lines or tall buildings as possible to ensure no further radio interference will occur.

Do not return this toy to the store!

We stand behind our product. If you experience difficulty assembling, charging or operating this toy, please call us and let us help.

We're here to help!

Call us toll-free at:

1-866-697-2869

8:00am - 5:00pm E.S.T. Mon-Fri

Or visit us on line at: www.newbright.com

Cautions

Do not recharge Battery Pack if it is hot or warm to the touch. Allow Battery Pack to cool before recharging. Recharging a hot or warm Battery Pack will shorten the life of the Pack.

Do not recharge a Battery Pack if it appears to be damaged or leaking.

Always unplug Battery Charger when not in use.

Always remove Battery Pack from Battery Compartment when not in use.

Do not dispose batteries in fire. Leakage, explosion and personal injury may occur.

Dispose of NiCd Battery Pack properly.

Do not attempt to disassemble Battery Pack or Charger.

Do not use Battery Charger for any use other than instructed in this booklet.

Only an adult should charge Batteries.

Do not attempt jumps or tricks with this vehicle.

NOTE: This equipment has been tested and found to comply with the limits for a Class B digital device, pursuant to Part 15 of the FCC Rules. These limits are designed to provide reasonable protection against harmful interference in a residential installation. This equipment generates, uses and can radiate radio frequency energy and, if not installed and used in accordance with the instructions, may cause harmful interference to radio communications. However, there is no guarantee that interference will not occur in a particular installation. If this equipment does cause harmful interference to radio or television reception, which can be determined by turning the equipment off and on, the user is encouraged to try to correct the interference by one or more of the following measures:

- Reorient or relocate the receiving antenna.
- Increase the separation between the equipment and receiver.
- Connect the equipment into an outlet on a circuit different from that to which the receiver is connected.
- Consult the dealer or an experienced radio/TV technician for help.