

<b>Prüfbericht-Nr.:</b> <i>Test Report No.:</i>	<b>CN21DD82 001</b>	<b>Auftrags-Nr.:</b> <i>Order No.:</i>	<b>158226611</b>	<b>Seite 1 von 18</b> <i>Page 1 of 18</i>	
<b>Kunden-Referenz-Nr.:</b> <i>Client Reference No.:</i>	<b>N/A</b>	<b>Auftragsdatum:</b> <i>Order date:</i>	<b>18.02.2021</b>		
<b>Auftraggeber:</b> <i>Client:</i>	<b>VTech Electronics Limited</b> <b>23F Tai Ping Industrial Center, Block 1, 57 Ting Kok Road, Tai Po, Hong Kong</b>				
<b>Prüfgegenstand:</b> <i>Test item:</i>	<b>LeapLand Adventures,</b> <b>ABC SMILE TV, L'aventure LeapLand</b>				
<b>Bezeichnung / Typ-Nr.:</b> <i>Identification / Type No.:</i>	<b>6132</b> <b>80-6132xx, (xx=00~99, see model differences for details)</b>				
<b>Auftrags-Inhalt:</b> <i>Order content:</i>	<b>FCC and ISED Certification</b>				
<b>Prüfgrundlage:</b> <i>Test specification:</i>	<b>FCC Part 15 Subpart C, ANSI C63.10-2013</b> <b>RSS-247 Issue 2, RSS-Gen Issue 5</b>				
<b>Wareneingangsdatum:</b> <i>Date of receipt:</i>	<b>04.03.2021</b>				
<b>Prüfmuster-Nr.:</b> <i>Test sample No.:</i>	<b>A003006149-001</b>				
<b>Prüfzeitraum:</b> <i>Testing period:</i>	<b>04.03.2021 - 15.03.2021</b>				
<b>Ort der Prüfung:</b> <i>Place of testing:</i>	<b>Hong Kong</b>				
<b>Prüflaboratorium:</b> <i>Testing laboratory:</i>	<b>TÜV Rheinland Hong Kong Ltd.</b>				
<b>Prüfergebnis*:</b> <i>Test result*:</i>	<b>Pass</b>				
<b>geprüft von / tested by:</b>			<b>kontrolliert von / reviewed by:</b>		
					
<b>25.05.2021</b>	<b>Felicia Chan / Assistant Engineer</b>		<b>25.05.2021</b>	<b>Sharon Li / Senior Manager</b>	
<b>Datum</b> <i>Date</i>	<b>Name / Stellung</b> <i>Name / Position</i>	<b>Unterschrift</b> <i>Signature</i>	<b>Datum</b> <i>Date</i>	<b>Name / Stellung</b> <i>Name / Position</i>	<b>Unterschrift</b> <i>Signature</i>
<b>Sonstiges / Other:</b> <b>FCC ID: G2R-6132</b> <b>IC: 1135D-6132 HVIN: 6132</b>					
<b>Zustand des Prüfgegenstandes bei Anlieferung:</b> <i>Condition of the test item at delivery:</i>			<b>Prüfmuster vollständig und unbeschädigt</b> <i>Test item complete and undamaged</i>		
* Legende: 1 = sehr gut      2 = gut      3 = befriedigend      4 = ausreichend      5 = mangelhaft P(ass) = entspricht o.g. Prüfgrundlage(n)      F(ail) = entspricht nicht o.g. Prüfgrundlage(n)      N/A = nicht anwendbar      N/T = nicht getestet					
Legend: 1 = very good      2 = good      3 = satisfactory      4 = sufficient      5 = poor P(ass) = passed a. m. test specification(s)      F(ail) = failed a. m. test specification(s)      N/A = not applicable      N/T = not tested					
<b>Dieser Prüfbericht bezieht sich nur auf das o.g. Prüfmuster und darf ohne Genehmigung der Prüfstelle nicht auszugsweise vervielfältigt werden. Dieser Bericht berechtigt nicht zur Verwendung eines Prüfzeichens.</b> <i>This test report only relates to the a. m. test sample. Without permission of the test center this test report is not permitted to be duplicated in extracts. This test report does not entitle to carry any test mark.</i>					



# Table of Content

	<b>Page</b>
<b>Cover Page</b> .....	<b>1</b>
<b>Table of Content</b> .....	<b>2</b>
<b>Product information</b> .....	<b>4</b>
<b>Manufacturers declarations</b> .....	<b>4</b>
<b>Product function and intended use</b> .....	<b>4</b>
<b>Submitted documents</b> .....	<b>4</b>
<b>Independent Operation Modes</b> .....	<b>5</b>
<b>Related Submittal(s) Grants</b> .....	<b>5</b>
<b>Remark</b> .....	<b>5</b>
<b>Test Set-up and Operation Mode</b> .....	<b>6</b>
<b>Principle of Configuration Selection</b> .....	<b>6</b>
<b>Test Operation and Test Software</b> .....	<b>6</b>
<b>Special Accessories and Auxiliary Equipment</b> .....	<b>6</b>
<b>Countermeasures to achieve EMC Compliance</b> .....	<b>6</b>
<b>Test Methodology</b> .....	<b>7</b>
<b>Radiated Emission</b> .....	<b>7</b>
<b>Field Strength Calculation</b> .....	<b>7</b>
<b>Test Setup Diagram</b> .....	<b>8</b>
<b>Test Facility</b> .....	<b>10</b>
<b>Test Laboratory Information</b> .....	<b>10</b>
<b>List of Test and Measurement Instruments</b> .....	<b>11</b>
<b>Measurement Uncertainty</b> .....	<b>12</b>
<b>Results FCC Part 15 – Subpart C / RSS-247 Issue 2</b> .....	<b>13</b>
<b>FCC 15.203 – Antenna Requirement 1</b> .....	<b>Pass</b> ..... <b>13</b>
<b>FCC 15.204 – Antenna Requirement 2</b> .....	<b>Pass</b> ..... <b>13</b>
<b>RSS-Gen 6.3 – External Control</b> .....	<b>Pass</b> ..... <b>13</b>
<b>RSS-Gen 8.3 – Antenna Requirement</b> .....	<b>Pass</b> ..... <b>13</b>
<b>FCC 15.207/ RSS-Gen 8.8 – Conducted Emission on AC Mains</b> .....	<b>N/A</b> ..... <b>14</b>
<b>FCC 15.247 (a)(2) / RSS-247 5.2 – 6dB Bandwidth Measurement</b> .....	<b>Pass</b> ..... <b>14</b>
<b>RSS-Gen 6.6 – Occupied Bandwidth</b> .....	<b>Pass</b> ..... <b>14</b>
<b>FCC 15.247(b)(3) / RSS-247 5.4 – Maximum Peak Conducted Output Power</b> .....	<b>Pass</b> ..... <b>15</b>

**FCC 15.247(e) / RSS-247 5.2 – Power Spectral Density.....Pass ..... 15**

**FCC 15.247(d) / RSS-247 5.5 – Spurious Conducted Emissions.....Pass ..... 16**

**FCC 15.205/ RSS-Gen 8.9 – Radiated Emissions in Restricted Frequency Bands ....Pass ..... 17**

**Appendix 1 – Test protocols ..... 9 pages**

**Appendix 2 – Test setup ..... 3 pages**

**Appendix 3 – EUT External Photos ..... 4 pages**

**Appendix 4 – EUT Internal Photos ..... 4 pages**

**Appendix 5 – RF exposure information..... 2 pages**

## Product information

### Manufacturers declarations

	<b>Transceiver</b>
Operating frequency range	2408 - 2472 MHz
Type of modulation	GFSK
Number of channels	3
Type of antenna	Integral PCB Antenna
Antenna gain (dBi)	0 dBi
Power level	fix
Type of equipment	stand alone radio device
Connection to public utility power line	No
Nominal voltage	3.0VDC
Independent Operation Modes	Transmitting

### Product function and intended use

The equipment under test (EUT) is a SRD Remote controller.

FCC ID: G2R-6132/ IC: 1135D-6132 **HVIN: 6132**

<b>Models</b>	<b>Product description</b>
6132	Remote controller

The manufacturer declares that all models listed in the below table are all identical in schematics, PCB layout, and electronic components used except model number.

Model No.	Sub model no.	Model Name	Color	Version	Language
6132	80-613203	LeapLand Adventures	Green	UK	English
6132	80-613200	LeapLand Adventures	Green	US	English
6132	80-613200	LeapLand Adventures	Green	CAN	English
6132	80-613206	L'aventure LeapLand	Green	CAN	FR
6132	80-613265	ABC Smile TV	Blue	FR	FR
6132	80-613267	ABC Smile TV	Blue	SP	SP
6132	80-613254	ABC Smile TV	Pink	GER	GER
6132	80-613264	ABC Smile TV	Blue	GER	GER
6132	80-613262	ABC Smile TV	Blue	NL	NL

### Submitted documents

Circuit Diagram  
 Block Diagram  
 Technical Description  
 User manual  
 Label

## Independent Operation Modes

The basic operation modes are:

- Transmitting mode.

For further information refer to User Manual

## Related Submittal(s) Grants

- This is a single application for certification of the Transmitter.

## Remark

The test results in this test report are only relevant to the tested sample and does not involve any assessment in the production.

## Test Set-up and Operation Mode

### Principle of Configuration Selection

**Emission:** The equipment under test (EUT) was configured to measure its highest possible radiation level. The test modes were adapted accordingly in reference to the instructions for use.

### Test Operation and Test Software

Test operation should refer to test methodology.

- A test mode sample is provided by the applicant to control the operating channel. The RF output power is fixed in the test mode sample. The setting of the RF output power used in the testing shall be fixed on the firmware of the final end product.

### Special Accessories and Auxiliary Equipment

- None

### Countermeasures to achieve EMC Compliance

- None

## Test Methodology

### Radiated Emission

The radiated emission measurements of the transmitter part were performed according to the procedures in ANSI C63.10-2013.

For measurement below 1GHz - the equipment under test (EUT) was placed at the middle of the 80 cm height turntable. For measurement above 1GHz - the EUT was placed at the middle of the 1.5 m height turntable and RF absorbing material was placed on ground plane between turntable and measuring antenna. During the testing, the EUT was operated standalone and arranged for maximum emissions. The EUT was tested in three orthogonal planes.

The investigation is performed with the EUT rotated 360°, the antenna height scanned between 1m and 4m, and the antenna rotated to repeat the measurements for both the horizontal and vertical antenna polarizations. Repeat the measurement steps until the maximum emissions were obtained.

All radiated tests were performed at an antenna to EUT with 3 meters distance, unless stated otherwise in particular parts of this test report.

### Field Strength Calculation

The field strength at 3 m was established by adding the meter reading of the spectrum analyzer to the factors associated with antenna correction factor, cable loss, preamplifiers and filter attenuation.

The equation is expressed as follow:

$$FS = R + AF + CF + FA - PA$$

Where FS = Field Strength in dBuV/m at 3 meters.  
R = Reading of Spectrum Analyzer in dBuV.  
AF = Antenna Factor in dB.  
CF = Cable Attenuation Factor in dB.  
FA = Filter Attenuation Factor in dB.  
PA = Preamplifier Factor in dB.

FA and PA are only be used for the measuring frequency above 1 GHz.

## Test Setup Diagram

Diagram of Measurement Configuration for Radiation Test

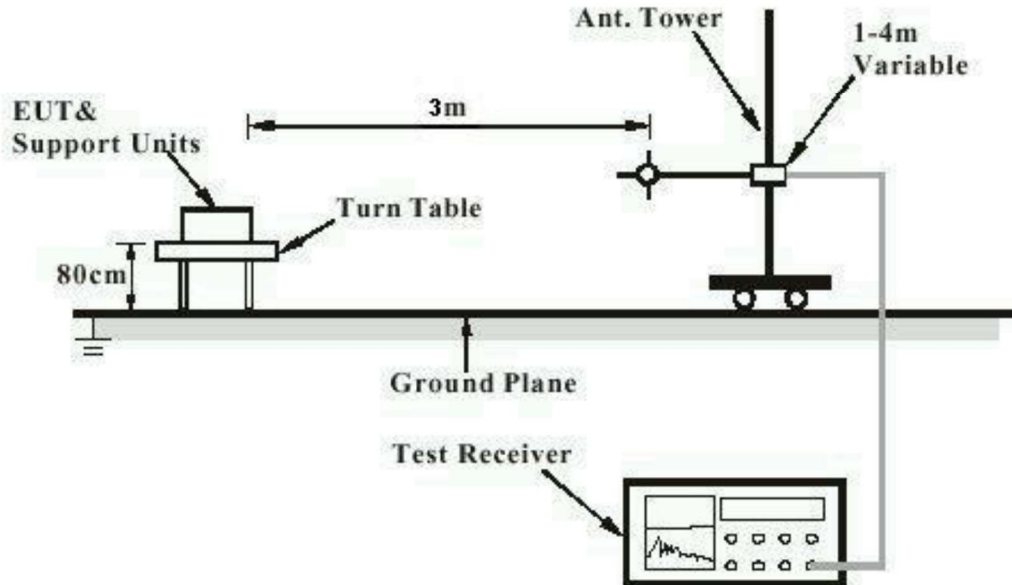

Note: Measurements above 1 GHz are done with a table height of 1.5m. In addition, there is RF absorbing material on the floor of the test site for above 1GHz measurement.

Diagram of Measurement Equipment Configuration for Mains Conduction Measurement (if applicable)

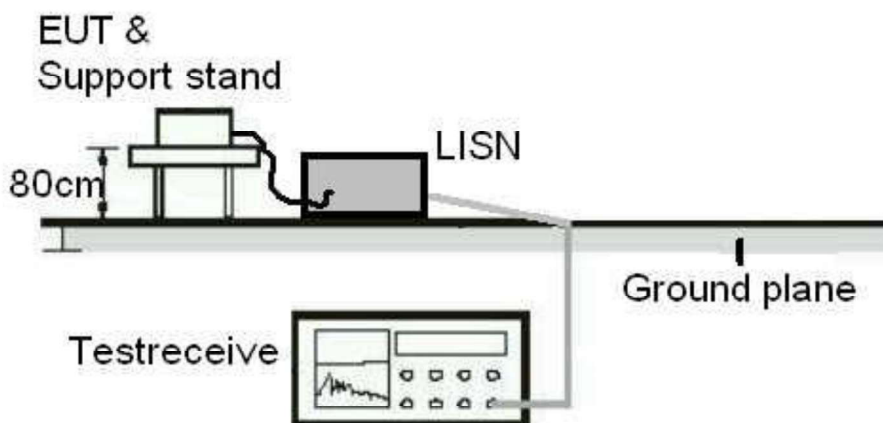



**Diagram of Equipment Configuration for Antenna-port Conducted Measurement (if applicable)**

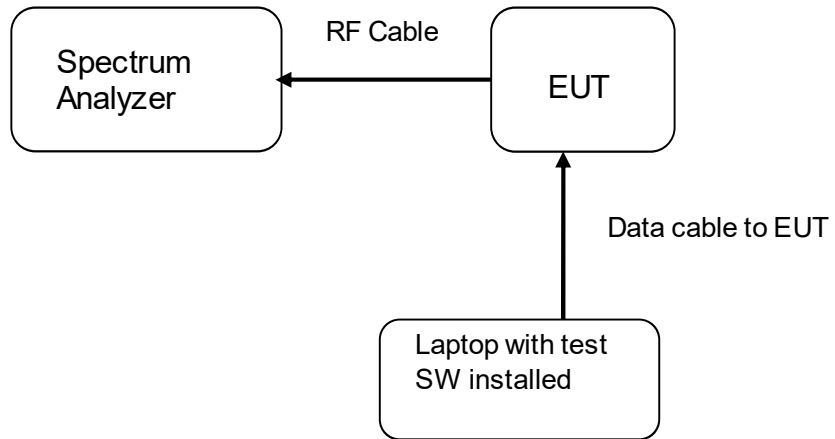

## Test Facility

### Test Laboratory Information

TÜV Rheinland Hong Kong Ltd.  
Address: 3-4, 11/F., Fou Wah Industrial Building, 10-16 Pun Shan Street, Tsuen Wan, N.T., Hong Kong  
Tel.: +852 2192 1000  
Fax: +852 2192 1001  
Email [service-gc@tuv.com](mailto:service-gc@tuv.com)  
Web: [www.tuv.com](http://www.tuv.com)

The test facility is recognized or accredited by the following organizations:

#### **FCC**

Type : Accredited Test Firm  
Designation Number : HK0013  
Test Firm Registration : 371735  
Number  
Scope : Intentional Radiators

#### **Industry Canada**

The 10m Semi-anechoic chamber used by TÜV Rheinland Hong Kong Ltd at Hong Kong Productivity Council has been registered by Certification and Engineering Bureau of Industry Canada for radio equipment testing

Test Site Registration Number : 26152

## List of Test and Measurement Instruments

### Radiated Emission

Equipment	Manufacturer	Type	Cal. Date	Due Date
Multi-functional Anechoic Chamber (SVSWR)	Albatross	N/A	04 Jan 21	04 Jan 22
Standard Gain Horn	ETS-Lindgren	3160-07	24 Nov 20	24 Nov 22
Standard Gain Horn	ETS-Lindgren	3160-08	24 Nov 20	24 Nov 22
Standard Gain Horn	ETS-Lindgren	3160-10	30 Nov 20	30 Nov 22
Double-Ridged Waveguide Horn	EMCO	3116	30 Nov 20	30 Nov 22
Double-Ridged Waveguide Horn	EMCO	3117	11 Nov 20	11 Nov 22
Test Receiver	R & S	ESU26	07 Oct 20	07 Oct 21
Coaxial cable	Huber+Suhner	SF118/11N/11N/12000MM	07 Jan 21	07 Jan 23
Microwave Preamplifier	COM-POWER Corporation	PAM-118A	06Mar 20	06 Mar 21
Preamplifier 18GHz to 40GHz with cable	A.H. Systems, Inc.	PAM-1840VH	29 Jan 21	29 Jan 22
High Pass Filter (cutoff freq. =1000MHz)	Trilithic	23042	30 Oct 19	30 Oct 21
High Frequency Cable	Pasternack	PE3VNA4001-3M	29 Jan 21	29 Jan 23
Multi-functional Anechoic Chamber (NSA)	Albatross	Nil	6-Jan-21	6-Jan-22
Bi-conical Antenna	R & S	HK116	15-Sep-20	15-Sep-22
Log Periodic Antenna	R & S	HL223	15-Sep-20	15-Sep-22
Coaxial cable	Huber+Suhner	SF118/11N/11N/12000MM	7-Jan-21	7-Jan-23
Active Loop Antenna	EMCO	6502	3-Nov-20	3-Nov-22

### Radio Test

Equipment	Manufacturer	Type	Cal. Date	Due Date
Spectrum Analyzer	R & S	FSV40	21 Jan 21	21 Jan 22

## Measurement Uncertainty

No.	Item	Measurement Uncertainty
1	Conducted emission 9KHz-150KHz	±3.2 dB
2	Conducted emission 150KHz-30MHz	±2.7 dB
3	Radiated emission 9KHz-30MHz	± 4.7 dB
4	Radiated emission 30MHz-1GHz	± 4.9 dB
5	Radiated emission 1GHz-18GHz	± 4.8 dB
6	Radiated emission 18GHz-26GHz	± 5.1 dB
7	Radiated emission 26GHz-40GHz	± 5.1 dB
8	Conducted spurious emissions	± 2.7 dB
9	RF Power, Conducted	± 0.9 dB
10	Occupied Bandwidth	± 1.86 %
11	Radio Frequency	2.4 GHz: ± 6.5 x 10 <sup>-8</sup>
12	Transmission Time	± 0.19 %

The reported expanded uncertainty of measurement is stated as the standard uncertainty of measurement multiplied by the coverage factor of k=2, which for the level of confidence is approximately 95%.

## Results FCC Part 15 – Subpart C / RSS-247 Issue 2

<b>FCC 15.203 – Antenna Requirement 1</b>		<b>Pass</b>
<b>FCC Requirement:</b> No antenna other than that furnished by the responsible party shall be used with the device		
<b>Results:</b>	a) Antenna type:	Integral PCB Antenna
	b) Manufacturer and model no:	N/A
	c) Peak Gain:	0 dBi
<b>Verdict:</b>	Pass	
<b>FCC 15.204 – Antenna Requirement 2</b>		<b>Pass</b>
<b>FCC Requirement:</b> An intentional radiator may be operated only with the antenna with which it is authorized. If an antenna is marketed with the intentional radiator, it shall be of a type which is authorized with the intentional radiator.		
<b>Results:</b>	Only one integral antenna can be used.	
<b>Verdict:</b>	N/A	
<b>RSS-Gen 6.3 – External Control</b>		<b>Pass</b>
<b>IC Requirement:</b> The device shall not have any external controls accessible to the user that enable it to be adjusted, selected or programmed to operate in violation of the limits prescribed in the applicable RSS.		
<b>Results:</b>	The device does not have any transmitter external controls accessible to the user that can be adjusted and operated in violation of the limits of this standard.	
<b>Verdict:</b>	Pass	
<b>RSS-Gen 8.3 – Antenna Requirement</b>		<b>Pass</b>
<b>IC Requirement:</b> When a measurement at the antenna connector is used to determine RF output power, the effective gain of the device’s antenna shall be stated, based on measurement or on data from the antenna manufacturer.		
<b>Results:</b>	a) Antenna type:	Integral PCB Antenna
	b) Manufacturer	N/A
	c) model no	N/A
	d) Gain with reference to an isotropic radiator:	0 dBi
<b>Verdict:</b>	Pass	

<b>FCC 15.207/ RSS-Gen 8.8 – Conducted Emission on AC Mains</b>	<b>N/A</b>
There is no AC power input or output ports on the EUT.	

<b>FCC 15.247 (a)(2) / RSS-247 5.2 – 6dB Bandwidth Measurement</b>	<b>Pass</b>
<b>FCC/ IC Requirement:</b> Systems using digital modulation techniques may operate in the 902 – 928 MHz, 2400 – 2483.5 MHz, and 5725 – 5850 MHz bands. The minimum 6dB bandwidth shall be at least 500kHz.	

Test Specification : ANSI C63.10 – 2013
Test date : 10.03.2021
Mode of operation : Tx mode
Supply voltage : 3VDC
Temperature : 23°C
Humidity : 51%

**Results:** For test protocols please refer to Appendix 1

Channel frequency (MHz)	6dB bandwidth (kHz)	Limit (kHz)
2408	1064	500
2438	813	500
2472	883.5	500

<b>RSS-Gen 6.6 – Occupied Bandwidth</b>	<b>Pass</b>
---	-------------

**FCC/ IC Requirement:** N/A

Test Specification : RSS-Gen
Test date : 10.03.2021
Mode of operation : Tx mode
Supply voltage : 3VDC
Temperature : 23°C
Humidity : 51%

**Results:** Pre-scan has been conducted to determine the worst-case mode from all possible combinations between available modulations and packet types.  
For test protocols refer to Appendix 1.

Frequency (MHz)	99% bandwidth (MHz)
2402	4.624
2440	3.720
2480	3.461

<b>FCC 15.247(b)(3) / RSS-247 5.4 – Maximum Peak Conducted Output Power</b>				<b>Pass</b>
<b>FCC/ IC Requirement:</b> For systems using digital modulation in the 902-928 MHz, 2400-2483.5 MHz, and 5725-5850MHz bands: 1 Watt (30dBm)				
Test Specification : ANSI C63.10 – 2013 Test date : 10.03.2021 Mode of operation : Tx mode Supply voltage : 3VDC Temperature : 23°C Humidity : 51%				
<b>Results:</b> For test protocols please refer to Appendix 1				
Frequency (MHz)	Cable loss (dB)	Measured Output Power (dBm)	Limit (dBm)	Verdict
2408	0.5	-1.58	30.0	Pass
2438	0.5	-1.48	30.0	Pass
2472	0.5	-1.32	30.0	Pass

<b>FCC 15.247(e) / RSS-247 5.2 – Power Spectral Density</b>				<b>Pass</b>
<b>FCC/ IC Requirement:</b> For digitally modulated systems, the power spectral density conducted from the intentional radiator to the antenna shall not be greater than 8 dBm in any 3 kHz band during any time interval of continuous transmission.				
Test Specification : ANSI C63.10 – 2013 Test date : 10.03.2021 Mode of operation : Tx mode Supply voltage : 3VDC Temperature : 23°C Humidity : 51%				
<b>Results:</b> For test protocols please refer to Appendix 1.				
Frequency (MHz)	Cable loss (dB)	Power density (dBm)	Limit (dBm)	Verdict
2408	0.5	-15.053	8.0	Pass
2438	0.5	-15.487	8.0	Pass
2472	0.5	-14.704	8.0	Pass

<b>FCC 15.247(d) / RSS-247 5.5 – Spurious Conducted Emissions</b>						<b>Pass</b>
Test Specification : ANSI C63.10 – 2013 Test date : 20.10.2020 Mode of operation : Tx mode Supply voltage : 3VDC Temperature : 25°C Humidity : 56%						
<b>FCC/ IC Requirement:</b> In any 100 kHz bandwidth outside the frequency band in which the spread spectrum or digitally modulated intentional radiator is operating, the radio frequency power that is produced by the intentional radiator shall be at least 20 dB below that in the 100 kHz bandwidth within the band that contains the highest level of the desired power, based on either an RF conducted or a radiated measurement.						
<b>Results:</b> Pre-scan has been conducted to determine the worst-case mode from all possible combinations between available modulations and data rate.  Only the worst cases is shown below. For test protocols refer to Appendix 1						
Operating frequency (MHz)	Spurious frequency (MHz)	Spurious Level (dBm)	Reference value (dBm)	Limit (dBm)	Margin (dB)	Verdict
2408	7225.1	-40.873	-1.255	-21.255	19.613	Pass
2438	7313.1	-37.355	1.514	-18.486	18.869	Pass
2472	7414.9	-39.946	-0.365	-20.365	19.581	Pass



<b>FCC 15.205/ RSS-Gen 8.9 – Radiated Emissions in Restricted Frequency Bands</b>		<b>Pass</b>
Test Specification : ANSI C63.10 – 2013 Test date : 06.03.2021 Mode of operation : Tx mode Frequency range : 9kHz – 25GHz Supply voltage : 3VDC Temperature : 25.2°C Humidity : 50%		
<b>FCC/ IC Requirement:</b> In any 100kHz bandwidth outside the frequency band at least 20dB below the highest level of the desired power. In addition, radiated emissions which fall in the restricted bands must also comply with the radiated emission general limits.		
<b>Results:</b> Pre-scan has been conducted to determine the worst-case mode from all possible combinations between available modulations and data rate.  All three transmit frequency modes comply with the field strength within the restricted bands. There is no spurious found below 30MHz.		
Mode: 2408 MHz TX		Vertical Polarization
Freq MHz	Level dBuV/m	Limit/ Detector dBuV/m
2390.000	41.29	74.0 / PK
2390.000	27.63	54.0 / AV
4816.000	39.80	74.0 / PK
4816.000	26.23	54.0 / AV
7224.000	45.20	74.0 / PK
7224.000	29.73	54.0 / AV
Mode: 2408 MHz TX		Horizontal Polarization
Freq MHz	Level dBuV/m	Limit/ Detector dBuV/m
2390.000	41.83	74.0 / PK
2390.000	28.05	54.0 / AV
4816.000	37.73	74.0 / PK
4816.000	26.22	54.0 / AV
7224.000	42.56	74.0 / PK
7224.000	29.84	54.0 / AV
Mode: 2438 MHz TX		Vertical Polarization
Freq MHz	Level dBuV/m	Limit/ Detector dBuV/m
4876.000	43.58	74.0 / PK
4876.000	25.85	54.0 / AV
7314.000	45.02	74.0 / PK
7314.000	31.81	54.0 / AV
Mode: 2438 MHz TX		Horizontal Polarization
Freq MHz	Level dBuV/m	Limit/ Detector dBuV/m
4876.000	49.33	74.0 / PK
4876.000	25.91	54.0 / AV
7314.000	44.27	74.0 / PK
7314.000	32.00	54.0 / AV

Mode: 2472 MHz TX		Vertical Polarization	
Freq MHz	Level dBuV/m	Limit/ Detector dBuV/m	
2483.500	41.20	74.0 / PK	
2483.500	27.17	54.0 / AV	
4944.000	38.19	74.0 / PK	
4944.000	26.84	54.0 / AV	
7416.000	41.65	74.0 / PK	
7416.000	29.50	54.0 / AV	
Mode: 2472 MHz TX		Horizontal Polarization	
Freq MHz	Level dBuV/m	Limit/ Detector dBuV/m	
2483.500	43.48	74.0 / PK	
2483.500	28.50	54.0 / AV	
4944.000	38.94	74.0 / PK	
4944.000	26.60	54.0 / AV	
7416.000	49.28	74.0 / PK	
7416.000	29.06	54.0 / AV	