

vtech[®]

User's Manual

Smart Stunts RC Cruiser[™]



© 2015 VTech
Printed in China
91-003056-000 

Dear Parent,

At VTech®, we know how important the first day of school is for your child. To help prepare preschoolers for this important event, VTech® has developed the *Preschool Learning™* series of interactive toys.

Preschool Learning™ features fun characters and inviting school themes that use technology to capture a child's attention and teach important preschool skills like spelling, counting and the alphabet. These vital skills are taught in a way that's both fun and highly engaging to maintain a child's interest. Children will also be introduced to fun school subjects such as art class, music class and even recess! With *Preschool Learning™*, learning is fun from day one!

At VTech®, we know that a child has the ability to do great things. That's why all of our electronic learning products are uniquely designed to develop a child's mind and allow them to learn to the best of their ability. We thank you for trusting VTech® with the important job of helping your child learn and grow!

Sincerely,

Your friends at VTech®

To learn more about VTech® toys, visit www.vtechkids.com

INTRODUCTION

Thank you for purchasing the **VTech® Smart Stunts RC Cruiser™**. Perform exciting tricks with the **Smart Stunts RC Cruiser™** by **VTech®**. Using the remote controller, drive Cody The **Smart Cub®** around in two speed modes and perform wheelies and spins while learning shapes, colors, directions and road safety. The RC cruiser also features realistic sounds, flashing headlights, 8 melodies and 2 fun sing-along songs.

ON/OFF & MODE SELECTOR

VOLUME SWITCH

SHAPE BUTTONS

LED HEADLIGHTS

REMOTE CONTROLLER

FORWARD/BACKWARD BUTTON

LEFT/RIGHT BUTTON

TURBO/NORMAL MODE BUTTON

LED LIGHT

INCLUDED IN THIS PACKAGE

- One VTech® Smart Stunts RC Cruiser™
- One Remote Controller
- One User's Manual

WARNING:

All packing materials, such as tape, plastic sheets, packaging locks and tags are not part of this toy, and should be discarded for your child's safety.

ATTENTION

Pour la sécurité de votre enfant, débarrassez-vous de tous les produits d'emballage tels que rubans adhésifs, feuilles de plastique, attaches et étiquettes. Ils ne font pas partie du jouet.

NOTE:

Please keep this user's manual as it contains important information.

Unlock the packaging locks:

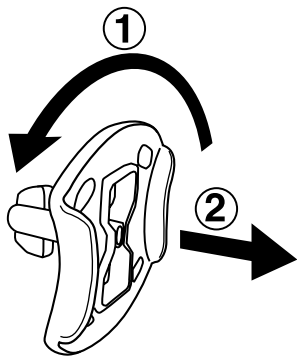

- ① Rotate the packaging lock 90 degrees counter-clockwise.
- ② Pull out the packaging lock and discard.

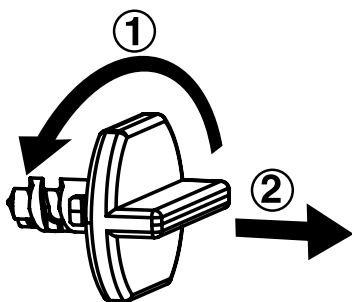

- ① Turn the packaging lock counter-clockwise several times.
- ② Pull out and discard the packaging lock.

GETTING STARTED

POWER SOURCE

The **Smart Stunts RC Cruiser™** operates on 4 AA batteries (AM-3/LR6). Batteries included for demo purposes only. For best performance, remove all factory-installed batteries and use new, alkaline batteries.

The Remote controller operates on 2 AA batteries. Batteries not included.

BATTERY INSTALLATION

Smart Stunts RC Cruiser™

1. Make sure the unit is **OFF**.
2. Locate the battery cover on the bottom of the unit. Use a screwdriver to loosen the screws.
3. Install 4 new “AA” size (AM-3/LR6) batteries following the diagram inside the battery box. (The use of new alkaline batteries is recommended for maximum performance.)
4. Replace the battery cover and tighten the screws to secure.

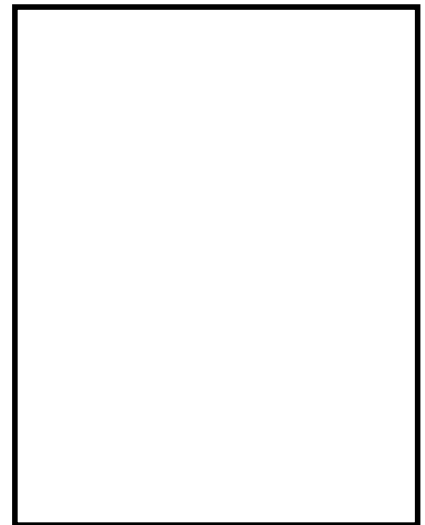

Remote controller

1. Make sure the unit is turned **OFF**.
2. Locate the battery cover on the back of the unit and open it with a screwdriver.screws.
3. Insert 2 AA batteries as illustrated.batteries
4. Replace the battery cover and tighten the screw to secure.

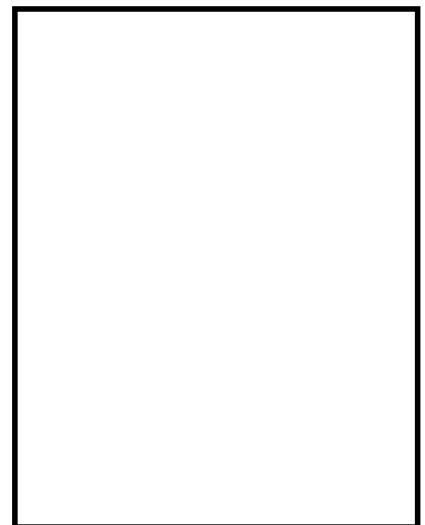

BATTERY NOTICE

- Use new alkaline batteries for maximum performance.
- Use only batteries of the same or equivalent type as recommended.
- Do not mix different types of batteries: alkaline, standard (carbon-zinc) or rechargeable (Ni-Cd, Ni-MH), or new and used batteries.
- Do not use damaged batteries.
- Insert batteries with the correct polarity.
- Do not short-circuit the battery terminals.
- Remove exhausted batteries from the toy.
- Remove batteries during long periods of non-use.
- Do not dispose of batteries in fire.
- Do not charge non-rechargeable batteries.
- Remove rechargeable batteries from the toy before charging (if removable).
- Rechargeable batteries are only to be charged under adult supervision.

ACTIVITIES NORMAL PLAY MODE

When the product is taken out of packaging, please press any button on the remote controller to start normal play after batteries are installed. You'll hear a few beep sounds that indicate you're in the normal play mode.

SAFETY GUIDELINE

For your child's safety, do not put the car on your clothing, body or hair. For best performance, only put the car on hard, flat surfaces.

SMART STUNTS RC CRUISER™

PRODUCT FEATURES

1. ON/OFF & MODE SELECTOR

This product has a slider that turns the unit **OFF** or **ON** and selects an activity. To turn the unit **ON**, slide the switch to any activity. To turn the unit **OFF**, slide the switch to **OFF**.

2. TWO SPEEDS

There are two speeds: Turbo Mode and Normal Mode. Press the Turbo/Normal button on the Remote controller, to enter Turbo mode; press it again to enter Normal mode.

Turbo Mode: The **Smart Stunts RC Cruiser™** will perform a stunt by spinning and rolling on its two back wheels. Use the 4 direction buttons to drive the car in full speed.

Normal Mode: The vehicle will drive normally using the remote controller.

3. SHAPE BUTTONS

Press one of the **SHAPE BUTTONS** to learn colors and shapes in Drive & Learn Mode, answer questions in Quiz Mode and listen to sing-along songs and melodies in Music Mode.

4. HEADLIGHTS

Headlights light up while learning and driving.

5. VOLUME SWITCH

The **VOLUME SWITCH** is located on the bottom of the car. Slide (Volume Control illustration) to the right for high volume or to the left for low volume.

6. AUTOMATIC SHUT-OFF

To preserve battery life, the **Smart Stunts RC Cruiser™** will shut off automatically after several minutes without any input. Slide (illustration

of the mode slider) to one of the 3 activities (play modes icons) to turn on the unit. We recommend that you turn off the unit when you've finished playing. Remove the batteries from the Smart Stunts RC Cruiser™ when not in use for an extended period of time.

REMOTE CONTROLLER

PRODUCT FEATURES

TURBO/NORMAL MODE BUTTON

Press the TURBO/NORMAL MODE BUTTON on the Remote controller and it will enter TURBO MODE; press it again and it will enter NORMAL MODE.

FORWARD/BACKWARD BUTTONS

Press the FORWARD/BACKWARD BUTTON to make the car go forward or backward and add fun sounds into the melodies in MUSIC MODE.

LEFT/RIGHT BUTTON

The LED LIGHTS will light up during play.

ACTIVITIES

1. DRIVE & LEARN MODE

Let's drive and learn. Press any SHAPE BUTTON to learn about colors, shapes and road safety.

Use the Remote controller to drive the car forward, backward, left or right. You can drive at a normal speed or press the TURBO BUTTON to see Cody do stunts and drive faster.

2. QUIZ MODE

Cody will ask questions about colors or shapes. Press a SHAPE BUTTON to answer. After three incorrect tries, you will be asked a new question.

MUSIC MODE

Let's play some music! Press any of the SHAPE BUTTONS to play a melody or a fun song about driving.

Press the buttons on the remote controller to add silly sounds into the melody or play a sing-along song while driving.

CARE & MAINTENANCE

1. Keep the unit clean by wiping it with a slightly damp cloth.
2. Keep the unit out of direct sunlight and away from any direct heat source.
3. Remove the batteries when the unit is not in use for an extended period of time.
4. Do not drop the unit on hard surfaces, and do not expose the unit to moisture or water.

TROUBLESHOOTING

If for some reason the program/activity stops working or malfunctions, please follow these steps:

1. Turn the unit **OFF**.
2. Interrupt the power supply by removing the batteries.
3. Let the unit stand for a few minutes, then replace the batteries.
4. Turn the unit **ON**. The unit should now be ready to play again.
5. If the product still does not work, replace with a new set of batteries.

If the problem persists, please call our Consumer Services Department at 1-800-521-2010 in the U.S. or 1-877-352-8697 in Canada, and a service representative will be happy to help you.

TECHNICAL SUPPORT

If you have a problem that cannot be solved by using this manual, we encourage you to visit us online or contact our Consumer Services Department with any problems and/or suggestions that you might have. A support representative will be happy to assist you. Before requesting support, please be ready to provide or include the information below:

- The name of your product or model number (the model number is typically located on the back or bottom of your product).
- The actual problem you are experiencing.
- The actions you took right before the problem occurred.

Internet: www.vtechkids.com

Phone: 1-800-521-2010 in the U.S. or 1-877-352-8697 in Canada

IMPORTANT NOTE

Creating and developing Electronic Learning products is accompanied by a responsibility that we at **VTech®** take very seriously. We make every effort to ensure the accuracy of the information, which forms the value of our products. However, errors sometimes can occur.

It is important for you to know that we stand behind our products and encourage you to call our Consumer Services Department at 1-800-521-2010 in the U.S. or 1-877-352-8697 in Canada with any problems and/or suggestions that you might have. A services representative will be happy to help you.

Note:

This equipment has been tested and found to comply with the limits for a Class B digital device, pursuant to Part 15 of the FCC Rules. These limits are designed to provide reasonable protection against harmful interference in a residential installation. This equipment generates, uses and can radiate radio frequency energy and, if not installed and used in accordance with the instructions, may cause harmful interference to radio communications. However, there is no guarantee that interference will not occur in a particular installation. If this equipment does cause harmful interference to radio or television reception, which can be determined by turning the equipment off and on, the user is encouraged to try to correct the interference by one or more of the following measures:

- Reorient or relocate the receiving antenna.
- Increase the separation between the equipment and receiver.
- Connect the equipment into an outlet on a circuit different from that to which the receiver is connected.
- Consult the dealer or an experienced radio/TV technician for help.

Caution : changes or modifications not expressly approved by the party responsible for compliance could void the user's authority to operate the equipment.

THIS DEVICE COMPLIES WITH PART 15 OF THE FCC RULES. OPERATION IS SUBJECT TO THE FOLLOWING TWO CONDITIONS: (1) THIS DEVICE MAY NOT CAUSE HARMFUL INTERFERENCE, AND (2) THIS DEVICE MUST ACCEPT ANY INTERFERENCE RECEIVED, INCLUDING INTERFERENCE THAT MAY CAUSE UNDESIRE OPERATION.

CAN ICES-3 (B)/NMB-3(B)

THIS DEVICE COMPLIES WITH INDUSTRY CANADA LICENCE-EXEMPT RSS STANDARD(S). OPERATION IS SUBJECT TO THE FOLLOWING TWO CONDITIONS: (1) THIS DEVICE MAY NOT CAUSE INTERFERENCE, AND (2) THIS DEVICE MUST ACCEPT ANY INTERFERENCE, INCLUDING INTERFERENCE THAT MAY CAUSE UNDESIRE OPERATION OF THE DEVICE.

LE PRÉSENT APPAREIL EST CONFORME AUX CNR D'INDUSTRIE CANADA APPLICABLES AUX APPAREILS RADIO EXEMPTS DE LICENCE. L'EXPLOITATION EST AUTORISÉE AUX DEUX CONDITIONS SUIVANTES : (1) L'APPAREIL NE DOIT PAS PRODUIRE DE BROUILLAGE, ET (2) L'UTILISATEUR DE L'APPAREIL DOIT ACCEPTER TOUT BROUILLAGE RADIOÉLECTRIQUE SUBI, MÊME SI LE BROUILLAGE EST SUSCEPTIBLE D'EN COMPROMETTRE LE FONCTIONNEMENT.



PRODUCT WARRANTY

This Warranty is applicable only to the original purchaser, is non-transferable and applies only to "VTech" products or parts. This product is covered by a 3-month Warranty from the original purchase date, under normal use and service, against defective workmanship and materials. This Warranty does not apply to (a) consumable parts, such as batteries; (b) cosmetic damage, including but not limited to scratches and dents; (c) damage caused by use with non-VTech products; (d) damage caused by accident, misuse, unreasonable use, immersion in water, neglect, abuse, battery leakage, or improper installation, improper service, or other external causes; (e) damage caused by operating the product outside the permitted or intended uses described by VTech in the owner's manual; (f) a product or part that has been modified (g) defects caused by normal wear and tear or otherwise due to the normal aging of the product; or (h) if any VTech serial number has been removed or defaced.

Prior to returning a product for any reason, please notify the VTech Consumer Services Department, by sending an email to vtechkids@vtechkids.com or calling 1-800-521-2010. If the service representative is unable to resolve the issue, you will be provided instructions on how to return the product and have it replaced under Warranty. Return of the product under Warranty must adhere to the following rules:

If VTech believes that there may be a defect in the materials or workmanship of the product and can confirm the purchase data and location of the product, we will at our discretion replace the product with a new unit or product of comparable value. A replacement product or parts assumes the remaining Warranty of the original product or 30 days from the date of replacement, whichever provides longer coverage.

THIS WARRANTY AND THE REMEDIES SET FORTH ABOVE ARE EXCLUSIVE AND IN LIEU OF ALL OTHER WARRANTIES, REMEDIES AND CONDITIONS, WHETHER ORAL, WRITTEN, STATUTORY, EXPRESS OR IMPLIED. IF VTECH CANNOT LAWFULLY DISCLAIM STATUTORY OR IMPLIED WARRANTIES THEN TO THE EXTENT PERMITTED BY LAW, ALL SUCH WARRANTIES SHALL BE LIMITED TO THE DURATION OF THE EXPRESS WARRANTY AND TO THE REPLACEMENT SERVICE AS DETERMINED BY VTECH IN ITS SOLE DISCRETION.

To the extent permitted by law, VTech will not be responsible for direct, special, incidental or consequential damages resulting from any breach of Warranty.

This Warranty is not intended to persons or entities outside the United States of America. Any disputes resulting from this Warranty shall be subject to the final and conclusive determination of VTech .