

Motion Detector SP804

Installation and Operating Instructions

These instructions should be read in conjunction with your system installation, and they should be retained for future reference.

PRODUCT LAYOUT

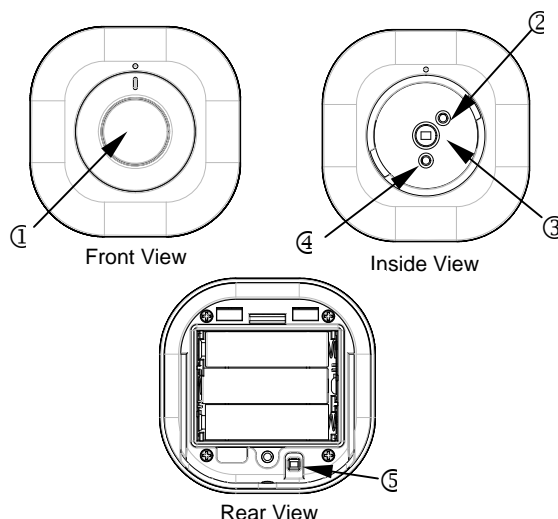

- ① Lens Cover (wall-lens cover & ceiling-lens cover)
- ② Light Sensor
- ③ PIR Sensor
- ④ Two-Color Indication LED (red & green)
- ⑤ Learning Key

INTRODUCTION

The Motion Detector is designed with two detecting sensors, Passive Infra-Red (PIR) sensor and light sensor, to detect movement within a protected area, operating at 868.30/923 MHz only.

The detector can be used as a security device or home automation device. When the detector is cooperated with security appliances, the detector is acting as a security device by detecting changes in infra-red radiation levels. If a person moves within or across the devices field of vision, a trigger radio signal will be transmitted to cause full alarm condition in order to frighten intruders away. Alternatively, when the detector is worked with Everspring USB Dongle (SA804), the detector can be set to perform the role of home automation device by detecting both changes in infra-red radiation levels and percentage of lux levels. Once night falls, the percentage of ambient illumination is lower than preset value. If a person moves within or across the devices field of vision, a trigger radio signal will be transmitted so as to turn connected lightings for better illumination.

Two mounting methods are provided for varying detection

range. The detector can be mounted on a wall for farther detecting distance but narrower coverage; while for ceiling mounting, shorter detecting distance can be made but desired coverage can be expected at user's disposal.

The Motion Detector is powered by 3 x AA 1.5V alkaline battery. When battery level drops below unacceptable level, the red LED will flash once every 30 seconds and transmit radio signal to the control panel. When this occurs, replace the batteries as soon as possible.

CHOOSING A MOUNTING LOCATION

The Motion Detector can be mounted either on a wall or under a ceiling. Before selecting a position for a Motion Detector the following points should be noted:

1. Do not position the detector facing a window/fan/air-conditioner or direct sunlight. Motion Detectors are not suitable for use in conservatories or draughty areas.
2. Do not position the detector directly above or facing any source of heat, e.g. fires, radiators, boiler etc.
3. Where possible, mount the detector so that the logical path of an intruder would cut across the fan pattern rather than directly towards the detector (FIGURE 1).

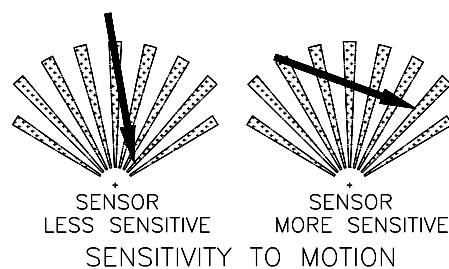

FIGURE 1

4. For best results, position the detector directly facing entrance.
5. Ensure that the position selected for the Motion Detector is within effective range of the system (refer to System Installation and Operating Manual).

INSTALLING THE MOTION DETECTOR

The unit can apply two ways of installations. Select a location for the unit based on the coverage angles shown in FIGURE 4b and FIGURE 5b. To install a detector:

1. Undo and remove the screw from the bottom edge of the detector to detach the rear cover (FIGURE 2).

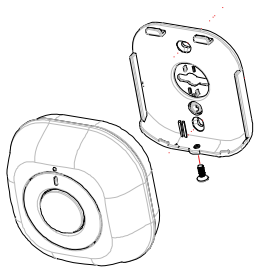

FIGURE 2

2. Unscrew the screw from the battery cover and remove the battery cover.
3. Insert 3 AA-size 1.5V alkaline batteries to the battery compartment, ensuring that correct polarity is put. (FIGURE 3)

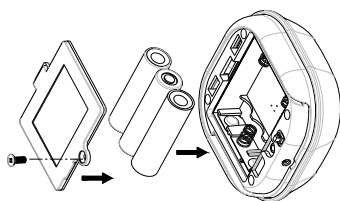

FIGURE 3

4. Decide the detector is to be wall-mounted (FIGURE 4a) or ceiling-mounted (FIGURE 5a). Hold the rear cover in position and mark the two mounting holes. Drill the holes, insert the plastic wall plugs and screw the rear cover to the wall or ceiling using the screws supplied.
5. Engage the detector to the rear cover firmly.

Wall Mounting

The recommended position for wall mounting is at the height of 1.8m (5.91 ft) from the floor. At this height, the optimum detection range is up to 10m (32.81ft). Also, in this position, the coverage angle is 110 degrees (FIGURE 4b).

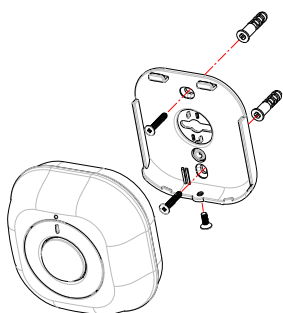

FIGURE 4a

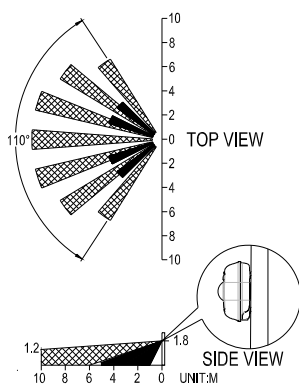

FIGURE 4b

Ceiling Mounting

The recommended position for ceiling mounting is at the height of 2.8m (9.19ft) from the floor. The optimum detection range is up to 5m (16.41ft) with coverage range of 360 degrees (FIGURE 5b).

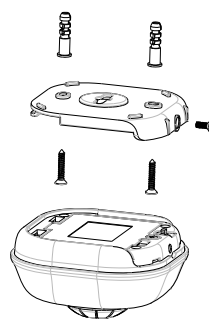

FIGURE 5a

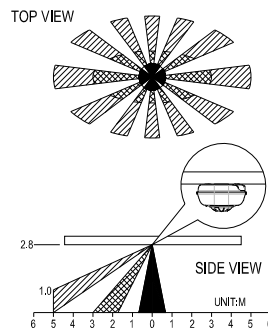

FIGURE 5b

SETTING THE MOTION DETECTOR

Coverage Range Adjustments

Two types of lens covers are provided for the detector. Wall-lens cover (FIGURE 6a) is to be used when the detector is wall-mounted, whereas ceiling-lens cover (FIGURE 6b) is to be used when the detector is ceiling-mounted. The coverage range adjustment is only applicable to ceiling-lens cover; choose correct lens cover before mounting.

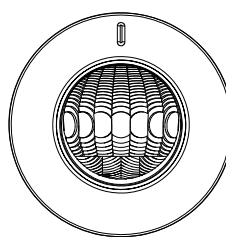

FIGURE 6a

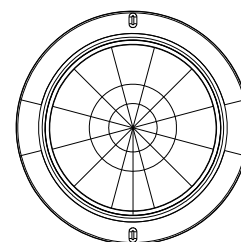

FIGURE 6b

The shading cap is composed of 12 segments for limiting the detection coverage, and each segment covers detection angle of 30 degrees (FIGURE 6c). Follow the grooves on the cap, cut the cap to a suitable size and place it onto the ceiling-lens cover (FIGURE 6d). The remaining segments are used for blanking off an undesirable detection area.

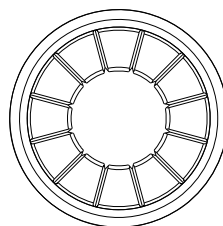

FIGURE 6c

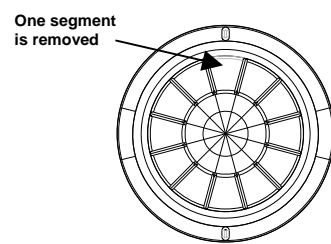

FIGURE 6d

When removing the wall-lens cover from the detector, simply turn the cover anticlockwise (FIGURE 6e).

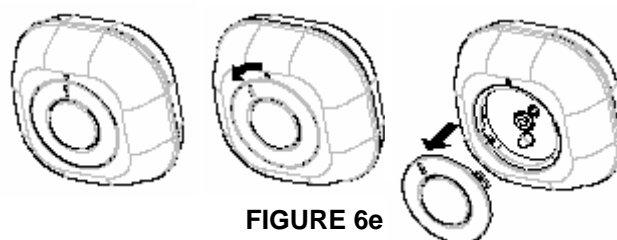

FIGURE 6e

Once the wall-lens cover is removed, reload the ceiling-lens cover and turn it clockwise, ensure that the mark on the cover is pointing towards and aligned with the mark on the detector (FIGURE 6f).

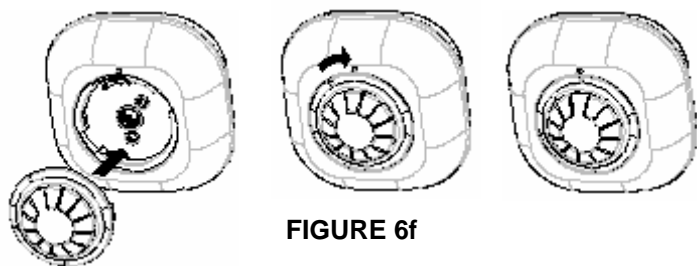

FIGURE 6f

Note: For detection of 360 degrees, simply reload the ceiling-lens cover without shading cap. No movements can be detected if the detector is reloaded with a shading cap which maintains 12 lens segments.

Warm-Up

It will take approximately 2 minutes to warm up after battery has been connected. During this time, LED will flash red once every 3 seconds. When a long beep is sounded with red LED turns on steadily for 5 seconds, it implies warm-up procedure is completed and the detector

LED Indication

Event	Status of Learning Key	LED Status	Sound Status
Press learning key to enter learning mode	Keep pressing the learning key more than 3 seconds	Within 3 seconds, green LED will illuminate steadily.	Beep once every second and continue 4 seconds
Under learning mode		Green LED flashes repeatedly	Rapid beep once every 3 seconds during 30-second countdown
Successful learning		Green LED on then off	Beep once
Failed learning		Green LED flashes rapidly 3 times	Rapid beep three times
Press learning key to clear ID code	Keep pressing the learning key for more than 3 seconds. Within 30-second countdown, press learning key again for at least 6 seconds, all ID codes will be cleared.	Repress the learning key during 6 seconds, green LED will illuminate steadily.	Beep once every second and continue 6 seconds
Successful clearance the ID code			Long beep once
Failed clearance the ID code	The learning key has been pressing for more than 3 seconds. However, failed to press learning key for at least 6 seconds within 30-second countdown.	Green LED flashes rapidly 3 times	Rapid beep three times
No ID code		Orange LED flashes repeatedly	Short beep once every 10 seconds

Note:

1. Green LED represents learning & clearing the ID code status and indications of RF signal emitting and receiving.
2. Red LED represents low battery and warm-up status.
3. Orange LED represents no ID code status and motion event triggers.
4. The detector can store up to 11 sets of appliance ID codes (e.g. SE802) and one control panel ID code (e.g. SA804). If 12th appliance ID code needs to be learned, the green LED will flash rapidly which implies ID code learning is failed.

is ready for detection.

Learning & Clearing the ID Code

The Motion Detector has its unique code. In order to prevent any unauthorized attempt to operate or disarm your system, you must let your control panel (e.g. SA804) or connected appliances learning its code for the system to operate correctly and vice versa.

To learn ID code, press and hold the learning key more than 3 seconds and then release immediately so as to enter ID code learning mode. 30-second countdown will start, enabling the control panel to learn the code. If code learning is successful, the detector will beep once and the green LED will be on shortly then off. If failure, three rapid beeps can be heard and green LED will flash rapidly three times.

To clear ID code, simply press and hold the learning key more than 3 seconds to enter ID code learning mode. Press learning key again for at least 6 seconds within 30-second countdown. Please refer to the table below to verify what kind of status the detector is in:

OPERATION

Mounting location is a critical factor for deciding the type of lens cover that will be used for the detector. Please decide whether the detector is going to be wall-mounted or ceiling-mounted before the operation procedure is carried on.

Wall Mounting

1. Place the wall-lens cover onto the detector.
2. By walking into a protected area within coverage of 110 degrees, the detector will now be triggered each time the detector senses movement. The orange LED on the detector will be illuminated and the associated appliances will be activated. For example, the SE802 siren will be sounded or indication of movement detection will be shown on the UnetSystem. It implies that the unit is working properly.

Ceiling Mounting

1. Place the ceiling-lens cover (cap free) onto the detector.
2. By walking into a protected area within coverage of 360 degrees, the detector will now be triggered each time the detector senses movement. The orange LED on the detector will be illuminated and the associated appliances will be activated. For example, the SE802 siren will be sounded or indication of movement detection will be shown on the UnetSystem. It implies that the unit is working properly.
3. Place the shading cap onto the ceiling-lens cover.
4. Check whether same results can be gained by walking into a protected area within coverage that is at your disposal.

ADVANCED OPERATION

The following information is provided for setting the functions of the detector via SA804 by using UnetSystem program. Please get familiar with the software of UnetSystem before getting starts.

Enabling/Disabling Sensor Detecting Function

This function is applied when users wish to enable/disable the detecting functions of the detector. To enable/disable the PIR/light sensors, users can send system On/Off command via UnetSystem. System On is for enabling the detecting function; whereas System Off is for disabling the detecting function. Please refer to the user manual of UnetSystem for more operating instructions.

Note: The default value is enabled. Reconnection of power supply will enable the sensor detecting function automatically.

Sensitivity Level (PIR sensor only)

In order to provide a best efficiency of the detector, it is recommended to test the detector with movements from a farthest end of the coverage area at the first time of use. If movements cannot be detected sensitively, simply adjust the sensitivity level. The sensitivity level can be set from 1 to 10; the larger the number, the higher the sensitivity.

Note: The default value is set in 6, which implies medium sensitivity.

Re-trigger Interval Setting (PIR sensor only)

This function is designed for setting the interval which allows PIR sensor to be re-triggered after the detector has been triggered. For example, the interval is set for 20 seconds. If a movement is detected, only wait after 20 seconds the detector can be triggered again if it detects another movement. No response will be made if the detector detects a movement in the meantime (FIGURE 7). The time interval can be set from 5 seconds to 3600 seconds; the larger the number, the longer the interval.

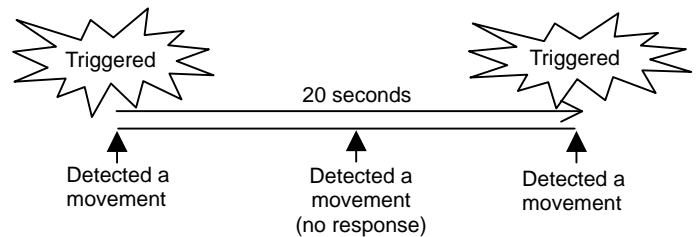

FIGURE 7

Note: The default value is set in 5, which implies that the detector can only be re-triggered after 5 seconds of interval.

On-Off Duration Setting

The function of on-off duration setting will be useful if the detector is connected with a module or lighting. Once the associated appliances are activated (turn to "On" status) after the detector has been triggered, they can be set to turn off after 5 to 3600 seconds of duration which is set by users beforehand. The larger the number it is, the longer the duration it will be.

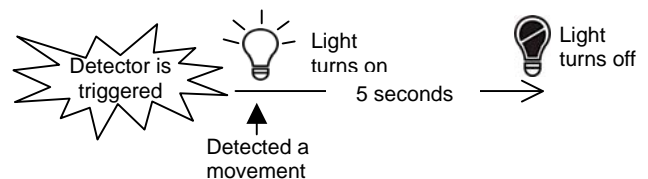

FIGURE 8

Note: The default value is set in 15, which implies that the detector will send a trigger-off command to associated appliances 15 seconds after been triggered.

Percentage of Lux Level Setting

The user can set a detecting percentage of lux level for triggering light sensor when a movement is detected. If the percentage of lux level of ambient illumination falls below this percentage, and a person moves across or within the protected area, the detector will emit RF signal to control panel or connected modules and lightings.

Percentage can be set from 1% to 100%; the larger the percentage, the higher the detecting lux level (the higher the brightness).

Note: The default value is set in 10, which implies 10% of lux level. You can check the percentage of current ambient illumination via UnetSystem before setting the percentage of lux level.

TROUBLESHOOTING

Symptom	Possible Cause	Recommendation
LED cannot be displayed	Run out of battery power	Check if the battery is fitted or replace a new battery.
	Check if reverse battery polarity	Refit the battery with correct polarity
LED displayed, but the detector cannot learn ID code or cannot be controlled	Check if ID code learning is successful with connected appliances	Follow the instructions on page 3 under setting section. Make sure the ID code of connected appliances is clear.
	Radio frequency interferences (868.30/923 MHz is emitted nearby)	Wait for a while and re-try
The detector not working	Check if the detector is out of order	Do not open up the detector and send it for repair
The detector working, but the connected appliances (or control panel) not working	Check if ID code learning is successful	Follow the instructions on page 3 under setting section.
	Distance is out of operating range	Reposition the mounting location of the detector and connected appliances (or control panel). Make sure the distance is within 200 meters.

SPECIFICATIONS

Battery	1.5V AA alkaline battery x 3
Range	Up to 200 meters line of sight
Warm Up Time	About 2 minutes
PIR Detection Coverage	Wall Mounting: Up to 10m x 110° (at 1.8m mounting height & 25°C) Ceiling Mounting: Up to 5m x 360° (at 2.8m mounting height & 25°C)
Frequency Range	868.30/923 MHz

*Specifications are subject to change without prior notice

A501111243R



WARNING:

Do not dispose of electrical appliances as unsorted municipal waste, use separate collection facilities.

Contact your local government for information regarding the collection systems available.

If electrical appliances are disposed of in landfills or dumps, hazardous substances can leak into the groundwater and get into the food chain, damaging your health and well-being.

When replacing old appliances with new once, the retailer is legally obligated to take back your old appliance for disposal at least for free of charge.

FEDERAL COMMUNICATIONS COMMISSION INTERFERENCE STATEMENT

This equipment has been tested and found to comply with the limits for a Class B digital device, pursuant to Part 15 of the FCC Rules. These limits are designed to provide reasonable protection against harmful interference in a residential installation. This equipment generates, uses and can radiate radio frequency energy and, if not installed and used in accordance with the instructions, may cause harmful interference to radio communications. However, there is no guarantee that interference will not occur in a particular installation. If this equipment does cause harmful interference to radio or television reception, which can be determined by turning the equipment off and on, the user is encouraged to try to correct the interference by one or more of the following measures:

- Reorient or relocate the receiving antenna.
- Increase the separation between the equipment and receiver.
- Connect the equipment into an outlet on a circuit different from that to which the receiver is connected.
- Consult the dealer or an experienced radio/TV technician for help.

CAUTION:

Any changes or modifications not expressly approved by the party responsible for compliance could void the user's authority to operate the equipment.

This device complies with Part 15 of the FCC Rules. Operation is subject to the following two conditions: (1) this device may not cause harmful interference, and (2) this device must accept any interference received, including interference that may cause undesired operation.