

<b>TEST REPORT</b>	
<b>Report Number..... :</b>	90028-22-72-22-PP001
<b>Date of issue .....</b>	Feb.09.2022
<b>Tested by (+signature) .....</b>	Duke <i>Duke Chen</i>
<b>Approved by (+signature).... :</b>	Jason <i>Jason gao</i>
<b>Testing Laboratory name..... :</b>	SLG-CPC Testlaboratory Co., Ltd.
<b>Address .....</b>	No. 11, Wu Song Road, Dongcheng District, Dongguan, Guangdong Province, China 523117
<b>Applicant's name .....</b>	Everspring Industry Co., Ltd.
<b>Address .....</b>	3rd Fl, No.50,Sec. 1, zhonghua Rd., Tucheng Dist., New Taipei city 236, Taiwan
<b>Manufacturer's name .....</b>	Dongguan Found Chain IOT Co., Ltd.
<b>Address .....</b>	Room 206, Building 6, Changping Jewelry City Cultural Industry Center, 568 Huanchang North Road, Changping Town, Dongguan City, Guangdong Province, China.
<b>Factory's name .....</b>	Dongguan Found Chain IOT Co., Ltd.
<b>Address .....</b>	Room 206, Building 6, Changping Jewelry City Cultural Industry Center, 568 Huanchang North Road, Changping Town, Dongguan City, Guangdong Province, China.
<b>Standard(s)..... :</b>	FCC 47 CFR Part 15, Subpart C
<b>Test item description..... :</b>	U-Net 5.0 Touch Keypad
<b>Trade Mark..... :</b>	/
<b>Model/Type reference..... :</b>	SK201-2
<b>FCC ID..... :</b>	FU5SK201-2
<b>Date of receipt of test item .. :</b>	Jan.17.2022
<b>Date (s) of performance of test..... :</b>	Jan.18.2022 to Feb.08.2022
<b>Test Report Form No..... :</b>	FCC CFR Part 15C_B1
<b>Master TRF .....</b>	Dated 2021-09
<b>Summary of Test Results..... :</b>	<b>Pass</b>
The Summary of Test Results based on a technical opinion belongs to the standard(s).	
<b>General disclaimer:</b>	
This report shall not be reproduced except in full, without the written approval of SLG-CPC Testlaboratory Co., Ltd. The test results in the report only apply to the tested sample.	



## TABLE OF CONTENTS

1	EUT TECHNICAL DESCRIPTION .....	4
2	SUMMARY OF TEST RESULT .....	5
3	TEST METHODOLOGY .....	6
3.1	GENERAL DESCRIPTION OF APPLIED STANDARDS .....	6
3.2	MEASUREMENT EQUIPMENT USED .....	6
3.3	DESCRIPTION OF TEST MODES .....	7
4	FACILITIES AND ACCREDITATIONS .....	8
4.1	FACILITIES .....	8
4.2	LABORATORY ACCREDITATIONS AND LISTINGS .....	8
5	TEST SYSTEM UNCERTAINTY .....	9
6	SETUP OF EQUIPMENT UNDER TEST .....	10
6.1	RADIO FREQUENCY TEST SETUP 1 .....	10
6.2	RADIO FREQUENCY TEST SETUP 2 .....	10
6.3	CONDUCTED EMISSION TEST SETUP .....	11
6.4	SUPPORT EQUIPMENT .....	12
7	TEST REQUIREMENTS .....	13
7.1	BANDWIDTH TEST .....	13
7.2	RADIATED SPURIOUS EMISSION .....	15
7.3	BAND EDGES REQUIREMENT .....	21
7.4	CONDUCTED EMISSIONS TEST .....	22
7.5	ANTENNA APPLICATION .....	23

**Modified Information**

Version	Report No.	Revision Data	Summary
Ver.1.0	90028-22-72-22-PP001	/	Original Version



## 1 EUT TECHNICAL DESCRIPTION

Product:	U-Net 5.0 Touch Keypad
Model Number:	SK201-2
Power supply:	<input checked="" type="checkbox"/> : 4.5V AA*3 Battery
Modulation:	FSK
Frequency Range:	923 MHz
Max Transmit Power:	96.26 dBuV/m
Antenna Gain:	0 dBi
Antenna:	WIRE Antenna
Temperature Range:	-10°C ~ +40°C

*Note: for more details, please refer to the User's manual of the EUT.*



## 2 SUMMARY OF TEST RESULT

FCC Part Clause	Test Parameter	Verdict	Remark
15.207	Conducted Emission	N/A	
15.209	Radiated Emission	PASS	
15.249	Radiated Spurious Emission	PASS	
15.249	Band edge test	PASS	
15.249	20dB Bandwidth	PASS	
15.203	Antenna Requirement	PASS	
NOTE1: N/A (Not Applicable) NOTE2: The report use radiated measurements in the restricted frequency bands. In addition, the radiated test is also performed to ensure the emissions emanating from the device cabinet also comply with the applicable limits.			

### RELATED SUBMITTAL(S) / GRANT(S):

This submittal(s) (test report) is intended for FCC ID: FU5SK201-2 filing to comply with Section 15.249 of the FCC Part 15, Subpart C Rules.



### 3 TEST METHODOLOGY

#### 3.1 GENERAL DESCRIPTION OF APPLIED STANDARDS

According to its specifications, the EUT must comply with the requirements of the following standards:

FCC 47 CFR Part 15, Subpart C

#### 3.2 MEASUREMENT EQUIPMENT USED

Equipment	Model	Manufacturer	S/N	Cal. Due
<b>RF Connected Test</b>				
Vector Signal Generator	Rohde & Schwarz	SMBV100B(6G)	101166	2022/07/30
Analog Signal Generator	Rohde & Schwarz	SMB100A(40G)	181333	2022/07/30
Signal Analyzer	Rohde & Schwarz	FSV40	101527	2022/05/24
Power Analyzer	Rohde & Schwarz	OSP-B157W8	N/A	2022/09/23
Wideband Radio Communication Tester	R&S	CMW270	101985	2022/07/30
Temperature&Humidity test chamber	ESPEC	VC 4018	/	2022/04/02
Wideband Radio Communication Tester	Rohde & Schwarz	CMW500	166898	2022/09/07
<b>Radiated Emission Test</b>				
EMI Test Receiver	KEYSIGHT	N9010A	MY56070465	2022/12/10
EMI Test Receiver	Rohde & Schwarz	FSV40	101511	2022/05/24
Bilog Antenna	Schwarzbeck	VULB 9163	01335	2023/04/28
Power Amplifier	EMEC	EM330	060676	2022/12/10
Cable	Tuyue	F4309	L-400-NmNm-12000	2022/12/10
Signal Analyzer	Rohde & Schwarz	FSV40	101511	2022/05/24
Horn Antenna	Schwarzbeck	BBHA9170	/	2022/10/09
Power Amplifier	Rohde & Schwarz	SCU-18F	180118	2022/05/17
Active Loop Antenna	ETS LINDGREN	6512	41623	2022/04/26
Test Software	Farad	EZ-EMC	Ver.CPC-3A1	/
<b>Conducted Emission Test</b>				
LISN	Schwarzbeck	NSLK 8127	8127-892	2022/03/19
EMI Test Receiver	R&S	ESR3	102124	2022/12/10
Pulse Limiter	R&S	ESH3-Z2	357.8810.52	2022/12/10
Test Software	Farad	EZ-EMC	Ver.CPC-3A1	/



### 3.3 DESCRIPTION OF TEST MODES

The EUT has been tested under its typical operating condition.

The EUT configuration for testing is installed on RF field strength measurement to meet the Commissions requirement and operating in a manner which intends to maximize its emission characteristics in a continuous normal application.

The Transmitter was operated in the normal operating mode. The TX frequency was fixed which was for the purpose of the measurements.

Test of channel included the lowest and middle and highest frequency to perform the test, then record on this report.

The EUT has been tested under its typical operating condition so those modulation and channel were used for all test.

EUT use new battery for test.

Pre-defined engineering program for regulatory testing used to control the EUT for staying in continuous transmitting and receiving mode is programmed.

#### Test Frequency and Channel list:

Channel	Frequency (MHz)	Channel	Frequency (MHz)	Channel	Frequency (MHz)
0	923				



## 4 FACILITIES AND ACCREDITATIONS

### 4.1 FACILITIES

All measurement facilities used to collect the measurement data are located at

No. 11, Wu Song Road, Dongcheng District, Dongguan, Guangdong Province, China 523117

The sites are constructed in conformance with the requirements of ANSI C63.7, ANSI C63.10 and CISPR Publication 22.

### 4.2 LABORATORY ACCREDITATIONS AND LISTINGS

#### Site Description

EMC Lab.	:	Accredited by ISED, October 04 2021 CAB identifier: CN0126 Company Number: 27767 Accredited by A2LA, October 04 2021 The Certificate Registration Number is 6325.01
Name of Firm	:	SLG-CPC Testlaboratory Co., Ltd.
Site Location	:	No. 11, Wu Song Road, Dongcheng District, Dongguan, Guangdong Province, China 523117





## 5 TEST SYSTEM UNCERTAINTY

The following measurement uncertainty levels have been estimated for tests performed on the apparatus:

Parameter	Uncertainty
Radio Frequency	$\pm 1 \times 10^{-5}$
Maximum Peak Output Power Test	$\pm 1.0\%$
Conducted Emissions Test	$\pm 3.08\text{dB}$
Radiated Emission Test	$\pm 4.60\text{dB}$
Occupied Bandwidth Test	$\pm 0.9\%$
Band Edge Test	$\pm 2.3\%$
All emission, radiated	$\pm 1.2\%$
Antenna Port Emission	$\pm 3\text{dB}$
Temperature	$\pm 3.2\%$
Humidity	$\pm 2.5\%$

Measurement Uncertainty for a level of Confidence of 95%



## 6 SETUP OF EQUIPMENT UNDER TEST

### 6.1 RADIO FREQUENCY TEST SETUP 1

The EUT wireless component's antenna ports(s) of the EUT are connected to the measurement instrument per an appropriate attenuator. The EUT is controlled by PC/software to emit the specified signals for the purpose of measurements.

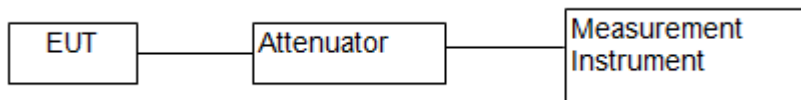

### 6.2 RADIO FREQUENCY TEST SETUP 2

The test site semi-anechoic chamber has met the requirement of NSA tolerance 4 dB according to the standards: ANSI C63.10. The test distance is 3m. The setup is according to the requirements in Section 13.1.4.1 of ANSI C63.10-2013 and CAN/CSA-CEI/IEC CISPR 22.

Below 30MHz:

The EUT is placed on a turntable 0.8 meters above the ground in the chamber, 3 meter away from the antenna (loop antenna). The Antenna should be positioned with its plane vertical at the specified distance from the EUT and rotated about its vertical axis for maximum response at each azimuth about the EUT. The center of the loop shall be 1 m above the ground. For certain applications, the loop antenna plane may also need to be positioned horizontally at the specified distance from the EUT.

30MHz-1GHz:

The EUT is placed on a turntable 0.8 meters above the ground in the chamber, 3 meter away from the antenna. The maximal emission value is acquired by adjusting the antenna height, polarisation and turntable azimuth. Normally, the height range of antenna is 1 m to 4 m, the azimuth range of turntable is 0° to 360°, and the receive antenna has two polarizations Vertical (V) and Horizontal (H).

Above 1GHz:

The EUT is placed on a turntable 1.5 meters above the ground in the chamber, 3 meter away from the antenna. The maximal emission value is acquired by adjusting the antenna height, polarisation and turntable azimuth. Normally, the height range of antenna is 1 m to 4 m, the azimuth range of turntable is 0° to 360°, and the receive antenna has two polarizations Vertical (V) and Horizontal (H).

#### (a) Radiated Emission Test Set-Up, Frequency Below 30MHz

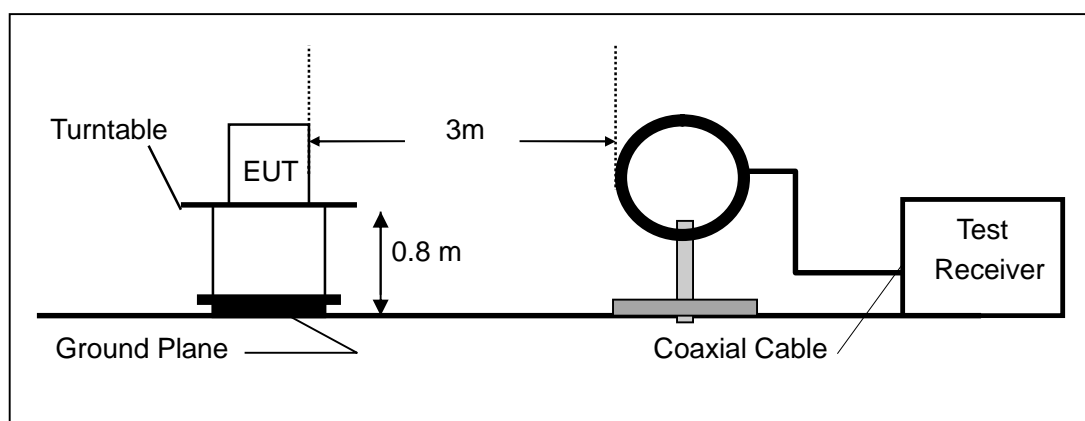



## (b) Radiated Emission Test Set-Up, Frequency Below 1000MHz

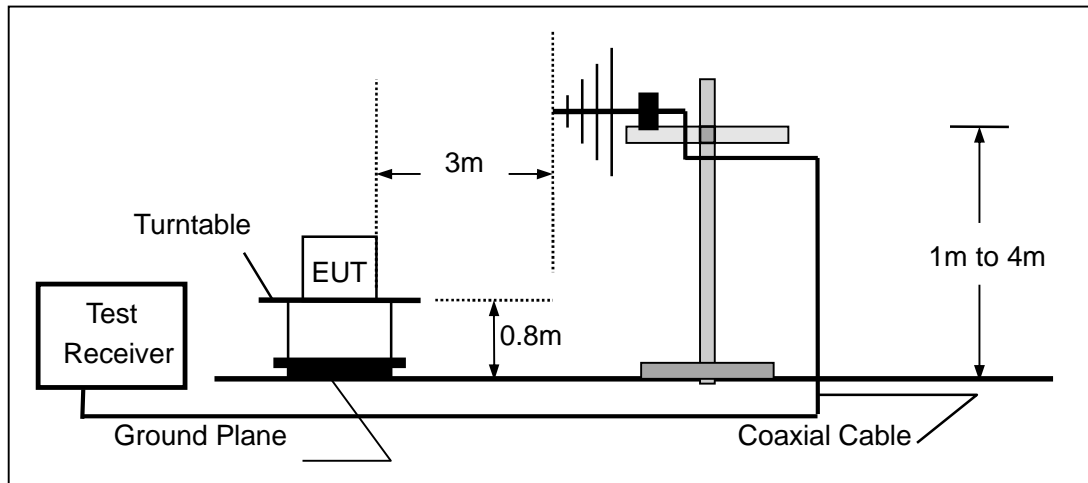

## (c) Radiated Emission Test Set-Up, Frequency above 1000MHz

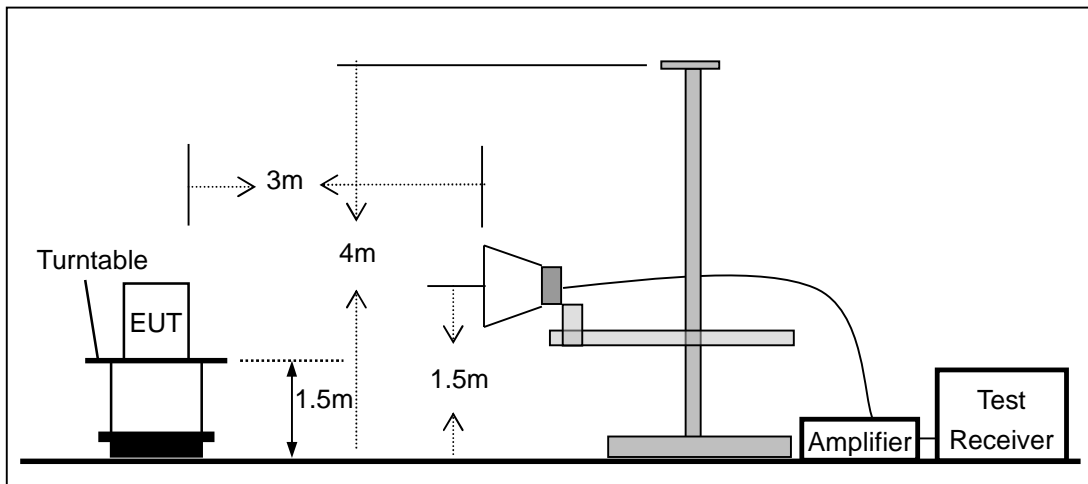
**6.3 CONDUCTED EMISSION TEST SETUP**

The mains cable of the EUT (maybe per AC/DC Adapter) must be connected to LISN. The LISN shall be placed 0.8 m from the boundary of EUT and bonded to a ground reference plane for LISN mounted on top of the ground reference plane. This distance is between the closest points of the LISN and the EUT. All other units of the EUT and associated equipment shall be at least 0.8m from the LISN.

Ground connections, where required for safety purposes, shall be connected to the reference ground point of the LISN and, where not otherwise provided or specified by the manufacturer, shall be of same length as the mains cable and run parallel to the mains connection at a separation distance of not more than 0.1 m.

According to the requirements in Section 13.1.4.1 of ANSI C63.10-2013 Conducted emissions from the EUT measured in the frequency range between 0.15 MHz and 30 MHz using CISPR Quasi-Peak and average detector mode.

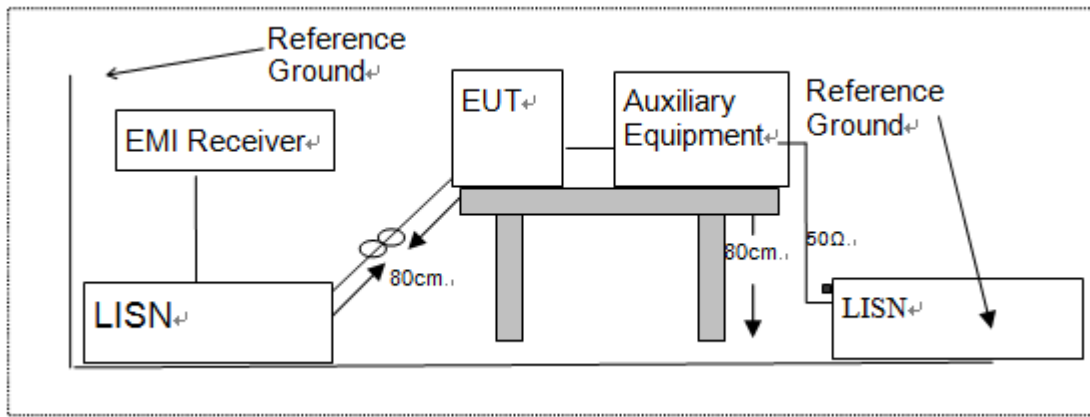

**6.4 SUPPORT EQUIPMENT**

EUT Cable List and Details			
Cable Description	Length (m)	Shielded/Unshielded	With / Without Ferrite
/	/	/	/

Auxiliary Cable List and Details			
Cable Description	Length (m)	Shielded/Unshielded	With / Without Ferrite

Auxiliary Equipment List and Details			
Description	Manufacturer	Model	Serial Number

**Notes:**

- 1) All the equipment/cables were placed in the worst-case configuration to maximize the emission during the test.
- 2) Grounding was established in accordance with the manufacturer's requirements and conditions for the intended use.
- 3) Unless otherwise denoted as EUT in 『Remark』 column , device(s) used in tested system is a support equipment



## 7 TEST REQUIREMENTS

### 7.1 BANDWIDTH TEST

#### 7.1.1 Applicable Standard

According to FCC Part 15.249

#### 7.1.2 Conformance Limit

N/A

#### 7.1.3 Test Configuration

Test according to clause 6.1 radio frequency test setup 1

#### 7.1.4 Test Procedure

The EUT was operating in controlled its channel. Printed out the test result from the spectrum by hard copy function.

The RF output of EUT was connected to the spectrum analyzer by RF cable and attenuator. The path loss was compensated to the results for each measurement.

Set to the maximum power setting and enable the EUT transmit continuously

Set RBW  $\geq$  1% of the 20 dB bandwidth(3KHz)

Set the video bandwidth (VBW)  $\geq$  RBW(10KHz).

Set Span= approximately 2 to 3 times the 20 dB bandwidth

Set Detector = Peak.

Set Trace mode = max hold.

Set Sweep = auto couple.

Measure the maximum width of the emission that is constrained by the frequencies associated with the two outermost amplitude points (upper and lower frequencies) that are attenuated by 20 dB relative to the maximum level measured in the fundamental emission.

Measure and record the results in the test report.

#### Test Results

Temperature:	26° C
Relative Humidity:	54%
ATM Pressure:	1011 mbar

Operatio n Mode	Channel Number	Channel Frequency (MHz)	20db Measurement Bandwidth (KHz)	Limit (kHz)	Verdict
FSK	0	923	250.7	N/A	PASS
Note: N/A (Not Applicable)					



Occupied Bandwidth  
FSK

Test Model Channel : 923MHz

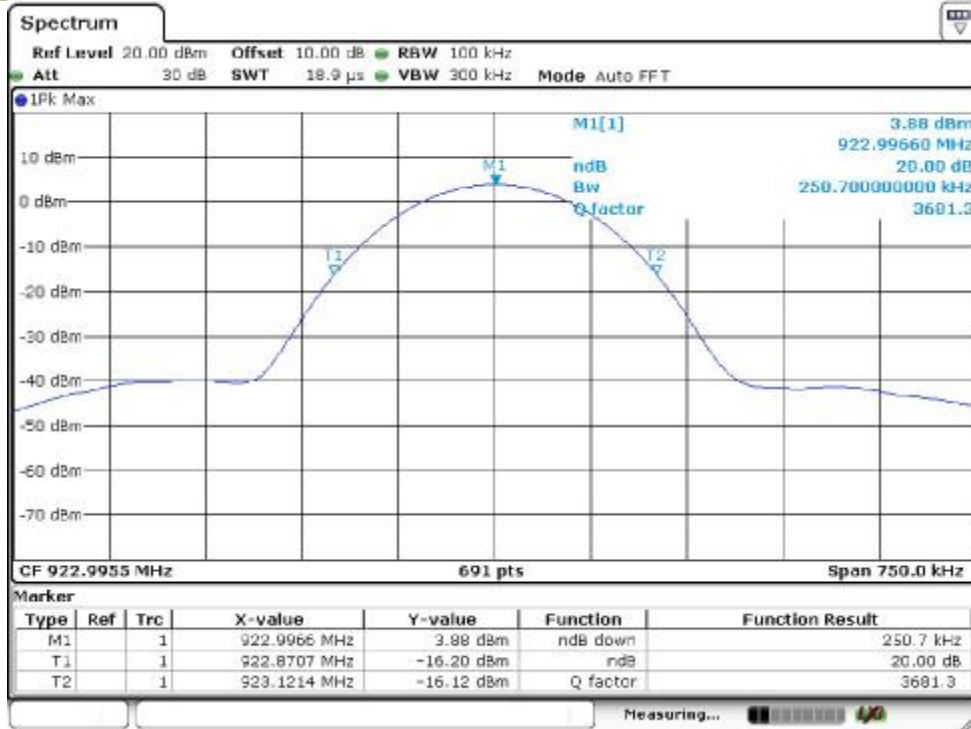



## 7.2 RADIATED SPURIOUS EMISSION

### 7.2.1 Applicable Standard

According to FCC Part 15.249 and 15.209

### 7.2.2 Conformance Limit

According to FCC Part 15.249: radiated emissions which fall in the restricted bands, as defined in §15.205(a), must also comply with the radiated emission limits specified in §15.209(a) (see §15.205(c)).

According to FCC Part 15.205, Restricted bands

MHz	MHz	MHz	GHz
0.090-0.110	16.42-16.423	399.9-410	4.5-5.15
10.495-0.505	16.69475-16.69525	608-614	5.35-5.46
2.1735-2.1905	16.80425-16.80475	960-1240	7.25-7.75
4.125-4.128	25.5-25.67	1300-1427	8.025-8.5
4.17725-4.17775	37.5-38.25	1435-1626.5	9.0-9.2
4.20725-4.20775	73-74.6	1645.5-1646.5	9.3-9.5
6.215-6.218	74.8-75.2	1660-1710	10.6-12.7
6.26775-6.26825	123-138	2200-2300	14.47-14.5
8.291-8.294	149.9-150.05	2310-2390	15.35-16.2
8.362-8.366	156.52475-156.52525	2483.5-2500	17.7-21.4
8.37625-8.38675	156.7-156.9	2690-2900	22.01-23.12
8.41425-8.41475	162.0125-167.17	3260-3267	23.6-24.0
12.29-12.293	167.72-173.2	3332-3339	31.2-31.8
12.51975-12.52025	240-285	3345.8-3358	36.43-36.5
12.57675-12.57725	322-335.4	3600-4400	(2)
13.36-13.41			

According to FCC Part 15.205, the level of any transmitter spurious emission in Restricted bands shall not exceed the level of the emission specified in the following table

Restricted Frequency(MHz)	Field Strength ( $\mu\text{V}/\text{m}$ )	Field Strength ( $\text{dB}\mu\text{V}/\text{m}$ )	Measurement Distance
0.009-0.490	2400/F(KHz)	20 log ( $\mu\text{V}/\text{m}$ )	300
0.490-1.705	24000/F(KHz)	20 log ( $\mu\text{V}/\text{m}$ )	30
1.705-30	30	29.5	30
30-88	100	40	3
88-216	150	43.5	3
216-960	200	46	3
Above 960	500	54	3

Remark :1. Emission level in  $\text{dB}\mu\text{V}/\text{m}=20 \log (\mu\text{V}/\text{m})$

2. Measurement was performed at an antenna to the closed point of EUT distance of meters.

3. Distance extrapolation factor  $=40 \log (\text{Specific distance}/ \text{test distance})(\text{dB})$ ;

Limit line= $\text{Specific limits}(\text{dB}\mu\text{V}) + \text{distance extrapolation factor}$ .

for the frequency ranges below 30 MHz, a narrower RBW is used for these ranges but the measured value should add a RBW correction factor (RBWCF) where RBWCF [dB]  $=10 \cdot \lg (100 [\text{kHz}]/\text{narrower RBW} [\text{kHz}])$ . , the narrower RBW is 1 kHz and RBWCF is 20 dB for the frequency 9 kHz to 150 kHz, and the narrower RBW is 10 kHz and RBWCF is 10 dB for the frequency 150 kHz to 30 MHz.



Field strength of fundamental and Field strength of harmonics Limit:

Fundamental frequency	Field strength of fundamental (millivolts/meter)	Field strength of harmonics (microvolts/meter)
902-928 MHz	50(94 dBV/m)	500(54 dBV/m)
2400-2483.5 MHz	50(94 dBV/m)	500(54 dBV/m)
5725-5875 MHz	50(94 dBV/m)	500(54 dBV/m)
24.0-24.25 GHz	250(108 dBV/m)	2500(68 dBV/m)

As shown in §15.35(b), for frequencies above 1000 MHz, the field strength limits in paragraphs (a) and (b) of this section are based on average limits. However, the peak field strength of any emission shall not exceed the maximum permitted average limits specified above by more than 20 dB under any condition of modulation

For this report

Fundamental Frequency	Field Strength Of Fundamental	Field Strength of Spurious Emissions
923 MHz	QP:94 dBuV/m at 3m distance	AV:54 dBuV/m at 3m distance
	PK:114 dBuV/m at 3m distance	PK:74 dBuV/m at 3m distance

### 7.2.3 Test Configuration

Test according to clause 6.2 radio frequency test setup 2

### 7.2.4 Test Procedure

This test is required for any spurious emission that falls in a Restricted Band, as defined in Section 15.205. It must be performed with the highest gain of each type of antenna proposed for use with the EUT. Use the following spectrum analyzer settings:

The EUT was placed on a turn table which is 0.8m above ground plane.

Maximum procedure was performed on the highest emissions to ensure EUT compliance.

Span = wide enough to fully capture the emission being measured

RBW = 1 MHz for  $f \geq 1$  GHz(1GHz to 25GHz), 100 kHz for  $f < 1$  GHz(30MHz to 1GHz)

VBW  $\geq$  RBW

Sweep = auto

Detector function = peak

Trace = max hold

Follow the guidelines in ANSI C63.10-2013 with respect to maximizing the emission by rotating the EUT, measuring the emission while the EUT is situated in three orthogonal planes (if appropriate), adjusting the measurement antenna height and polarization, etc. A pre-amp and a high pass filter are required for this test, in order to provide the measuring system with sufficient sensitivity. Allow the trace to stabilize. The peak reading of the emission, after being corrected by the antenna factor, cable loss, pre-amp gain, etc., is the peak field strength, which must comply with the limit specified in Section 15.35(b). Submit this data.

Now set the VBW to 10 Hz, while maintaining all of the other instrument settings. This peak level, once corrected, must comply with the limit specified in Section 15.209. If the dwell time per channel of the hopping signal is less than 100 ms, then the reading obtained with the 10 Hz VBW may be further adjusted by a "duty cycle correction factor", derived from  $20\log(\text{dwell time}/100 \text{ ms})$ , in an effort to demonstrate compliance with the 15.209 limit. Submit this data.

Repeat above procedures until all frequency measured was complete.





## 7.2.5 Test Results

Temperature:	24° C
Relative Humidity:	53%
ATM Pressure:	1011 mbar

### ■ Spurious Emission below 30MHz (9KHz to 30MHz)

Freq. (MHz)	Ant.Pol. H/V	Emission Level(dBuV/m)		Limit 3m(dBuV/m)		Over(dB)	
		PK	AV	PK	AV	PK	AV
--	--	--	--	--	--	--	--

Note: the amplitude of spurious emission that is attenuated by more than 20dB below the permissible limit has no need to be reported.

Distance extrapolation factor =  $40\log(\text{Specific distance/ test distance})$  (dB);

Limit line = Specific limits(dBuV) + distance extrapolation factor

### ■ Field Strength of the fundamental signal

Freq. (MHz)	Ant.Pol. H/V	Emission Level(dBuV/m)		Limit 3m(dBuV/m)		Over(dB)	
		PK	QP	PK	QP	PK	QP
923	V	91.71	68.48	114	94	-22.29	-25.52
923	H	96.26	74.27	114	94	-17.74	-19.73

Note: (1) Correct Factor = Antenna Factor + Cable Loss - Amplifier Gain

(2) Emission Level = Reading Level + Probe Factor + Cable Loss



■ Spurious Emission Above 1GHz (1GHz to 25GHz)

Test mode: FSK

Frequency:923MHz

Channel : 0

Freq. (MHz)	Ant.Pol. H/V	Emission Level(dBuV/m)		Limit 3m(dBuV/m)		Over(dB)	
		PK	AV	PK	AV	PK	AV
1847.51	V	55.80	45.95	74	54	-18.2	-8.05
2771.44	V	56.61	48.21	74	54	-17.39	-5.79
4327.94	V	55.11	49.77	74	54	-18.89	-4.23
1847.38	H	57.35	47.53	74	54	-16.65	-6.47
2773.97	H	57.72	47.41	74	54	-16.28	-6.59
4510.87	H	55.23	49.35	74	54	-18.77	-4.65

- Note:** (1) All Readings are Peak Value (VBW=3MHz) and Peak Value (VBW=10Hz).  
 (2) Emission Level= Reading Level+Correct Factor +Cable Loss.  
 (3) Correct Factor= Ant\_F + Cab\_L - Preamp  
 (4) The reading of emissions are attenuated more than 20dB below the permissible limits or the field strength is too small to be measured.



■ Spurious Emission below 1GHz (30MHz to 1GHz)

All modes have been tested, and the worst result recorded was report as below:

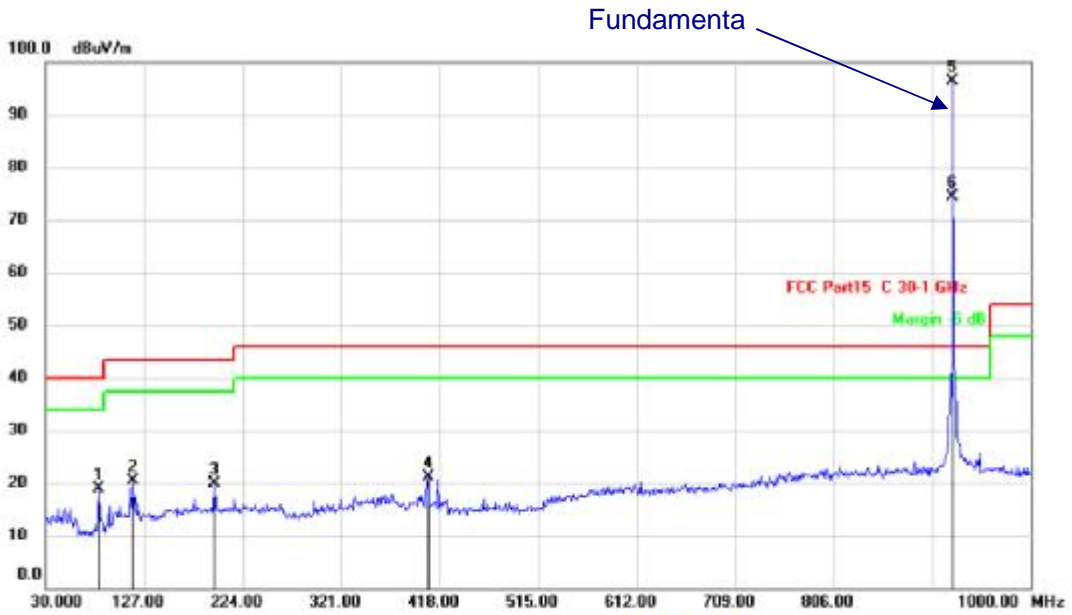

Site: Polarization: **Horizontal** Temperature: 23 °C  
 Limit: FCC Part15 C 30-1 GHz Power: DC 4.5 V Humidity: 51 %  
 Mode: TX Mode  
 Note:

No.	Mk.	Freq. MHz	Reading Level dBuV	Correct Factor dB	Measure- ment dBuV/m	Limit dB/m	Over dB	Detector
1		82.3800	48.00	-29.21	18.79	40.00	-21.21	QP
2		116.3300	46.55	-26.16	20.39	43.50	-23.11	QP
3		195.8700	46.19	-26.19	20.00	43.50	-23.50	QP
4		406.3599	42.76	-21.62	21.14	46.00	-24.86	QP
5	*	923.3700	111.42	-15.16	96.26	46.00	50.26	peak
6	X	923.3700	89.43	-15.16	74.27	46.00	28.27	QP

\*:Maximum data x:Over limit !:over margin

< Reference Only



Fundamenta



Site: Polarization: **Vertical** Temperature: 23 °C  
 Limit: FCC Part15 C 30-1 GHz Power: DC 4.5V Humidity: 51 %  
 Mode: TX Mode  
 Note:

No.	Mk.	Freq. MHz	Reading Level dBuV	Correct Factor dB	Measure- ment dBuV/m	Limit dB/m	Over dB	Detector
1		83.3500	49.34	-28.93	20.41	40.00	-19.59	QP
2		92.0800	47.16	-26.44	20.72	43.50	-22.78	QP
3		176.4700	48.78	-27.13	21.65	43.50	-21.85	QP
4		195.8700	48.30	-26.19	22.11	43.50	-21.39	QP
5	*	923.3700	106.87	-15.16	91.71	46.00	45.71	peak
6	X	923.3700	83.64	-15.16	68.48	46.00	22.48	QP

\*:Maximum data    x:Over limit    !:over margin

< Reference Only



### 7.3 BAND EDGES REQUIREMENT

#### 7.3.1 Applicable Standard

According to FCC Part 15.249(d)

#### 7.3.2 Test Configuration

Test according to clause 6.2 radio frequency test setup 2

#### 7.3.3 Test Procedure

Follow the guidelines in ANSI C63.10: Clause 6.10

Pre-Scan has been conducted to determine the worst-case mode from all possible combinations between available modulations, data rates and antenna ports(if EUT with antenna diversity architecture). The lowest, middle and highest channels were selected for the final test as listed below.

#### 7.3.4 Test Results

Temperature:	24° C
Relative Humidity:	53%
ATM Pressure:	1011 mbar

#### Fundamental and Band edges and Harmonics Result

Operation Mode: TX 923MHz      Test Data: Feb 22, 2022  
 Test Result: Pass      Test By: KEN

Emission Level (MHz)	Emission Level (dB $\mu$ V/m)	Limit (dB $\mu$ V/m)	Margin (dB)	Ant. Polar H/V	Detector
902	26.96	46	-19.04	V	QP
902	29.71	46	-16.29	H	QP
928	25.49	46	-20.51	V	QP
928	27.21	46	-18.79	H	QP



## 7.4 CONDUCTED EMISSIONS TEST

### 7.4.1 Applicable Standard

According to FCC Part 15.207(a)

### 7.4.2 Conformance Limit

Frequency(MHz)	Conducted Emission Limit	
	Quasi-peak	Average
0.15-0.5	66-56	56-46
0.5-5.0	56	46
5.0-30.0	60	50

Note: 1. The lower limit shall apply at the transition frequencies  
 2. The limit decreases in line with the logarithm of the frequency in the range of 0.15 to 0.50MHz.

### 7.4.3 Test Configuration

Test according to clause 6.3 conducted emission test setup

### 7.4.4 Test Procedure

The EUT was placed on a table which is 0.8m above ground plane.  
 Maximum procedure was performed on the highest emissions to ensure EUT compliance.  
 Repeat above procedures until all frequency measured were complete.

### 7.4.5 Test Results

Not Applicable.  
 The EUT is battery-powered



## 7.5 ANTENNA APPLICATION

### 7.5.1 Antenna Requirement

Standard	Requirement
FCC CRF Part 15.203	An intentional radiator shall be designed to ensure that no antenna other than that furnished by the responsible party shall be used with the device. The use of a permanently attached antenna or of an antenna that uses a unique coupling to the intentional radiator shall be considered sufficient to comply with the provisions of this section. The manufacturer may design the unit so that a broken antenna can be replaced by the user, but the use of a standard antenna jack or electrical connector is prohibited. This requirement does not apply to carrier current devices or to devices operated under the provisions of §15.211, §15.213, §15.217, §15.219, or §15.221. Further, this requirement does not apply to intentional radiators that must be professionally installed, such as perimeter protection systems and some field disturbance sensors, or to other intentional radiators which, in accordance with §15.31(d), must be measured at the installation site. However, the installer shall be responsible for ensuring that the proper antenna is employed so that the limits in this part are not exceeded.

For intentional device, according to FCC 47 CFR Section 15.203, an intentional radiator shall be designed to ensure that no antenna other than that furnished by the responsible party shall be used with the device.

### 7.5.2 Result

PASS.

- The EUT has 1 antennas: an WIRE Antenna for 923M, antenna has a gain of 0 dBi;
- Note:
- Antenna use a permanently attached antenna which is not replaceable.
  - Not using a standard antenna jack or electrical connector for antenna replacement
  - The antenna has to be professionally installed (please provide method of installation)

which in accordance to section 15.203, please refer to the internal photos.

-----The end-----