

# HSP02

# MOTION DETECTOR



The Motion Detector is a Z-Wave™ enabled device which is fully compatible with any Z-Wave™ enabled network. Z-Wave™ enabled devices displaying the Z-Wave™ logo can also be used with the unit regardless of brand. Inclusion of this Motion Detector in a Wireless Controller system allows remote control of connected modules when the detector is triggered.

The Motion Detector is designed with two sensors - Passive Infra-Red (PIR) sensor and light sensor - in order to fulfill the purpose of security and home automation. When the detector is working with security appliances, it is acting as a security device by detecting changes in infra-red radiation levels. If a person moves within or across the detection field, a trigger radio signal will be transmitted to cause full alarm condition. Alternatively, when the detector is working with home automation appliances, the detector can detect both changes in infra-red radiation levels and percentage of lux levels. At night, when a person moves within or across the field of detection, a trigger radio signal will be transmitted so as to turn on the connected lightings for better illumination.

## Overview and Battery Installation

The PIR Detector adopts a CR2 3.0V Lithium battery which under normal conditions will have typical lifespan in excess of 1 year. To install the battery, simply undo the fixing screw and remove the rear cover, and then place the battery into the compartment with polarity correctly fitted. Then refit and secure the rear cover.

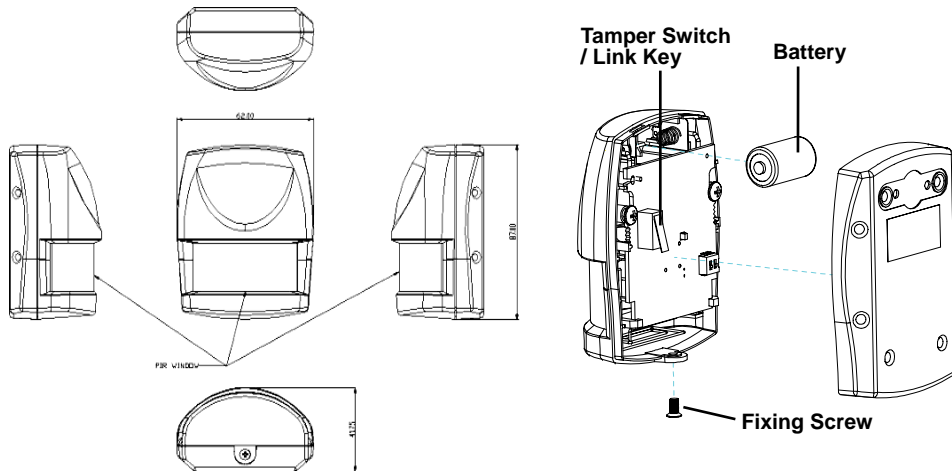

## Include to or Exclude from Z-Wave™ Network

In the rear casing, there is a link key (tamper switch) which is used to carry out inclusion, exclusion, association or reset. When the detector is first powered up, the LED flashes on and off alternately and repeatedly at 2-second intervals. It implies that it has not been assigned a node ID and cannot work with Z-Wave enabled devices. The detector will stay “awake” for 10 minutes when power is first applied to allow time for configuration. Please get familiar with the terms below before starting the operations.

Function	Description
Inclusion	Add a Z-Wave enabled device (e.g. Motion Detector) to Z-Wave network.
Exclusion	Delete a Z-Wave enabled device (e.g. Motion Detector) from the network.
Association	After inclusion, you have to define the relationship between devices. Through association, device can be assigned as master/slave, and specify which slave is going to be controlled by which master.
Reset	Restore Detector to factory default.

The table below lists an operation summary of basic Z-Wave functions. Please refer to the instructions for your Z-Wave™ Certificated Primary Controller to access the setup function, and to include/exclude/associate devices. The detector executes the function of auto inclusion when...

### Auto Inclusion

The function of auto inclusion will be executed as long as the detector does not have node ID and in situations where...

1. The power is first applied.
2. The execution of exclusion/reset is successful where the stored node ID is cleared.

**Note:** Auto inclusion timeout is 4 minutes during which the node information of explorer frame will be emitted once every 5 seconds. Unlike “inclusion” function as shown in the table below, the execution of auto inclusion is free from pressing the link key on the detector.

Function	Description	Indication
No node ID	The Z-Wave Controller does not allocate a node ID to the unit.	2-second on, 2-second off

Inclusion	1. Have Z-Wave Controller entered inclusion mode.	
	2. Pressing link key 3 times within 1.5 seconds will enter inclusion mode.	
	3. The unit will stay "awake" for 10 minutes.	
Exclusion	1. Have Z-Wave Controller entered exclusion mode.	
	2. Pressing link key 3 times within 1.5 seconds will enter exclusion mode.	
	3. The unit will stay "awake" for 10 minutes.	2-second on, 2-second off (for 2 minutes)
Reset	1. Press link key 3 times within 1.5 seconds.	
	2. Within 1 second, press and hold link key for 5 seconds until LED is OFF.	
	3. IDs are cleared and all settings will be reset to factory default.	2-second on, 2-second off (for 2 minutes)
Association	1. Have Z-Wave Controller entered association mode.	
	2. Pressing link key 3 times within 1.5 seconds will enter association operation. The unit will stay "awake" for 10 minutes.	
	3. There are two groupings – 1 and 2. Refer to Z-Wave's Grouping as described on page 4.	
<p>✗Including a node ID allocated by Z-Wave Controller means inclusion. Excluding a node ID allocated by Z-Wave Controller means exclusion.</p> <p>✗Failed or successful results in including/excluding the node ID can be viewed from the Z-Wave Controller.</p> <p>✗When "Exclusion" is completed, the parameter 1 of configuration will be restored to default value, while other parameters will retain their settings before exclusion. Press the tamper switch (link key) once and the green LED will flash for about 25 seconds.</p>		

## Choosing a Mounting Location

The PIR Detector is suitable for mounting in dry interior locations only.

The recommended position for a PIR Detector is in the corner of a room mounted at a height between 1.8 and 2m. At this height, the detector will have a maximum range of up to 9m with a field of view of 110°, subject to the position for the PCB

being set in 5. (FIGURE 1 & 2) The position of the PCB inside the PIR can be set to 5 different positions to adjust the range of the detector. Setting the PCB in position 3 will reduce the range to 6m approximately, with position 1 providing a range of 3m approximately. The recommended position setting for the PCB is in position 5.

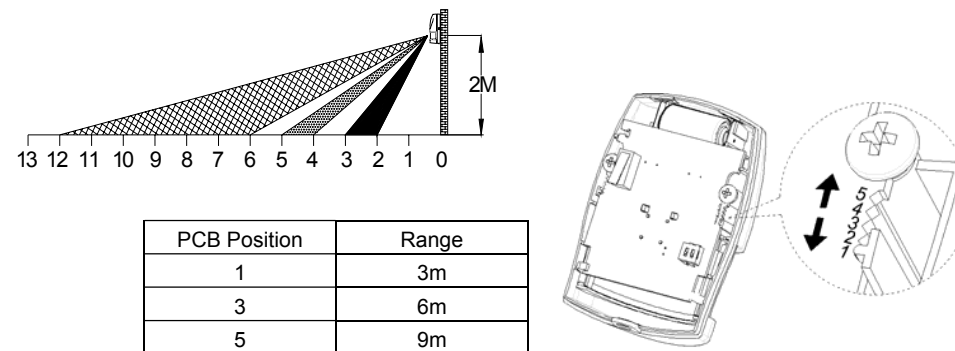

FIGURE 1 & 2

When considering and deciding upon the mounting position for the detector the following points should be considered to ensure trouble free operation:

1. Do not locate the detector facing a window or where it is exposed to or facing direct sunlight. PIR Detectors are not suitable for use in conservatories.
2. Do not locate the detector where it is exposed to ventilators.
3. Do not locate the detector directly above a heat source, (e.g. fire, radiator, boiler, etc).
4. Where possible, mount the detector in the corner of the room so that the logical path of an intruder would cut across the fan detection pattern. PIR detectors respond more effectively to movement across the device than to movement directly towards it. (FIGURE 3)

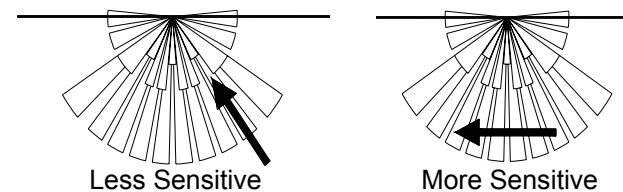

FIGURE 3

- Do not locate the detector in a position where it is subject to excessive vibration.
- Ensure that the position selected for the PIR detector is within effective range of the system, (refer to System Installation and Operating Manual).

**Note:** When the system is armed, household pets should not be allowed to go into an area protected by a PIR detector as their movement would trigger the PIR and generate a false alarm.

## Installation

### Ensure that the system is in Test Mode.

- Undo and remove the fixing screw from the bottom edge of the detector. Carefully pull the bottom edge of the detector away from the rear cover and then slide down to release the top clips. (FIGURE 2)

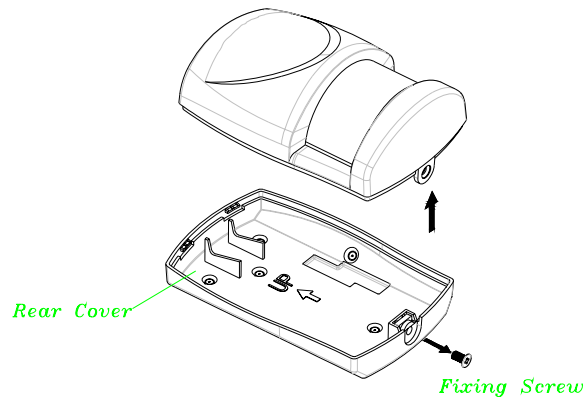

FIGURE 2

- Carefully drill out the required mounting holes in the rear cover according to whether the unit is being mounted in a corner or against a flat wall.

**Note:** Use 1<sup>st</sup> group of mounting holes to fulfill corner mounting installation. Use 2<sup>nd</sup> group of mounting holes for flat wall installation. (FIGURE 3a & 3b)

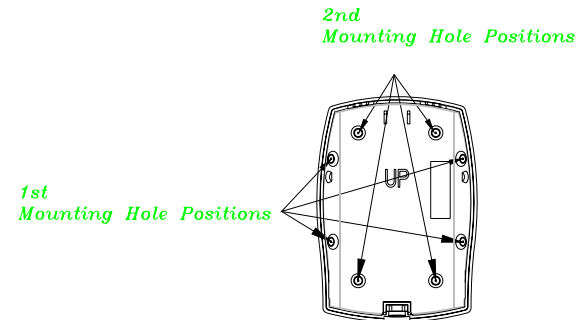
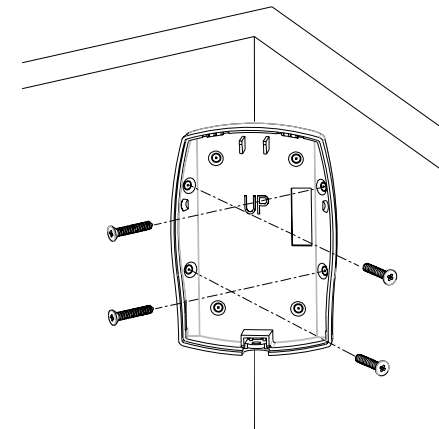

FIGURE 3a



Corner mounting  
FIGURE 3b

- Using the rear cover as a template, mark the positions of the fixing holes on the wall.
- Fix the rear cover to the wall using the two 18mm No .4 screws and 25mm wall plugs, (a 5mm hole will be required for the wall plugs). Do not over-tighten the fixing screws as this may distort or damage the cover.
- Configure the detector as described below. Remember that on initial installation that the device needs to be tested.

6. Check that the detector PCB is located and set in the correct position to provide the required detection range. To adjust the PCB position, simply slide it up or down ensuring that the location legs are aligned with the required position number marked on the board.
7. To refit the detector to the rear cover and locate the clips in the top edge into the rear cover. Push the lower edge of the detector into place and refit the fixing screw in the bottom edge of the detector to secure in position. Do not over-tighten the fixing screws as this may damage the casing.

## Settings

### Warm-Up

It will take approximately 2 minutes to warm up after battery has been connected. When the red LED turns on steadily for 5 seconds, it implies warm-up procedure is completed and the detector is ready for detection.

### Test Mode and Operation

1. After power on, PIR will warm-up for about 2 minutes. If the unit stores no node ID then the LED will continuously flash to remind the user for inclusion. Distance test for PIR can only be done after inclusion.
2. Test mode:  
After inclusion, if Tamper switch is not pressed, the unit will enter test mode. When PIR is triggered, the red LED will light up once and retrigger time is about 5 seconds. However, if Tamper switch is pressed, the unit will enter normal mode. When PIR is triggered, the red LED will not light up and retrigger time is based on set up value.
3. By walking into a protected area within coverage of 110 degrees, the detector will now be triggered each time the detector senses movement. The associated appliances will be activated. For example, siren will sound or indication of movement detection will be shown on the controller. It implies that the unit is working properly.

## Programming

### 1. Z-Wave's Group (Association Command Class Version 2)

The unit supports two association groups with one node support for Grouping 1 and five nodes support for Grouping 2. This has the effect that when the unit is triggered, all devices associated with the unit will receive the relevant reports.

There are two kinds of reports: ALARM\_REPORT and SENSOR\_BINARY\_REPORT.

#### 1-1 Grouping 1 (Max. node = 1)

##### 1-1-1 Power Applied Command

The unit will send ALARM\_REPORT command to the nodes of Grouping 1 to inform the device that the unit is powered up.

ALARM\_REPORT Command:  
**[Command Class Alarm, Alarm Report, Alarm Level = 0x01, Alarm Type = 0x02]**

##### 1-1-2 Intrusion Event Report (Binary Sensor Report)

Once the Detector detected a movement, the unit will send SENSOR\_BINARY\_REPORT to the nodes of Grouping 1 to inform there is an intrusion event. Once the movement is stopped, SENSOR\_BINARY\_REPORT will be sent again to the associated devices.

BINARY SENSOR REPORT Command:  
 Event Present:  
**[Command Class Sensor Binary, Sensor Binary Report, Value = 255 (0xFF)]**  
 Event Clear:  
**[Command Class Sensor Binary, Sensor Binary Report, Value = 0 (0x00)]**

##### 1-1-3 Low Battery Report (Alarm Report Class)

Upon Detector status being changed, the unit will check its battery status simultaneously. When the battery level of the unit drops to an unacceptable level, the unit will emit ALARM\_REPORT command to the nodes of Grouping 1.

ALARM\_REPORT Command:  
**[Command Class Alarm, Alarm Type = 0x01, Alarm Level = 0x01]**

##### 1-1-4 Tamper Event Report

When the tamper switch (link key) is pressed for over 10 seconds and then released, the unit will emit ALARM\_REPORT command to the

nodes of Grouping 1.

ALARM\_REPORT Command:  
**[Command Class Alarm, Alarm Type = 0x03, Alarm Level = 0x01]**

### 1-2 Grouping 2 (Max. node = 5)

#### 1-2-1 Control other Z-Wave Devices

When the detector is triggered, the unit will send BASIC\_SET command which contains a value that is adjust able, to the nodes of Grouping 2. For instance, the brightness level of a lamp module can be fixed according to the set value. However, the BASIC\_SET command will also be sent to the nodes of Grouping 2. For instance, a lamp module will be turned off after receiving the BASIC\_SET command.

Basic Set Command:  
 Event Present:  
**[Command Class Basic, Basic Set, Value = 255 (0xFF)]**  
 Event Clear:  
**[Command Class Basic, Basic Set, Value = 0 (0x00)]**

## 2. Z-Wave's Configuration

The following information is for someone that has some experience in setting up a Z-Wave system or some one that has computer software running a Z-Wave controller. Please get familiar with software of Z-Wave controller before getting started.

To save power consumption for the battery, RF power of HSP02 is in off mode ordinarily. Please press Tamper switch once to turn on the RF power for 30 seconds in order to start function set up, and the user can see the LED starts flashing. If set up is not finished within 30 seconds, press Tamper switch once more to continue the set up (or press Tamper switch 3 times within 1.5 seconds, and the unit will stay "awake" for 10 minutes).

#### 2-1 Basic Set Level

When Basic Set Command is sent where contains a value, the receiver will take it for consideration; for instance, if a lamp module receives the Basic Set command then the carried value will set the dim level of the lamp module.

Example:

0 : OFF  
 1-99, 0xFF: ON (Binary Switch Device)  
 Dim Level (Multilevel Switch Device)

Function	Parameter Number	Size	Range	Default
Basic Set level	1	1	1 ~99, 0xFF	0xFF

**Configuration Command**

#### 2-2 Enabling/Disabling Sensor Detecting Function

Sensor function Enable/Disable: To start or stop the sensor functions

Note 1 Sensor includes PIR Sensor & Light Sensor

Note 2 Default for HSP02 is Enable, when power applied, the unit is at Enable status

**Configuration Command**

Function	Parameter Number	Size	Range	Default
Group1/Group2 Enable/Disable	2	1	0=Group1 Disable Group2 Disable	1 ( Enable)
			1=Group1 Enable Group2 Enable	
			2=Group1 Enable Group2 Disable	
			3=Group1 Disable Group2 Enable	

#### 2-3 Sensitivity Level (PIR sensor only)

In order to provide a best efficiency of the detector, it is recommended to test the detector with movements from a farthest end of the coverage area at first time of use. If movements cannot be detected sensitively, simply adjust the sensitivity level with Configuration Parameter #3. This parameter can be configured with the value of 1 through 10, where 1 means low sensitivity and 10 means highest sensitivity.

Function	Parameter Number	Size	Range	Default
Sensitivity Level	3	1	1~10	6

**Configuration Command**

## 2-4 Re-trigger Interval Setting (PIR sensor only)

The Configuration parameter that can be used to adjust the interval of being re-triggered after the detector has been triggered as Configuration Parameter #4. No response will be made during this interval if a movement is presented. The time interval can be set between 5 secs to 3600 secs.

Function	Parameter Number	Size	Range	Default
Re-trigger Interval	4	1 or 2 (if value > 127)	5~3600 (sec)	180

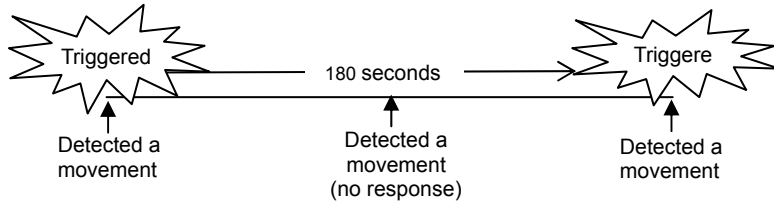

## 2-5 Lux Level

The user can set a detecting percentage of lux level which determines when the light sensor will be activated. If percentage of lux level of ambient illumination falls below this percentage, and a person moves across or within the protected area, the detector will emit Z-Wave ON Command (i.e. Basic Set Command (Value = Basic Set Level)) to controller and activate connected modules and lighting. Percentage can be set from 1% to 100%.

Function	Parameter Number	Size	Range	Default
Lux Level	5	1	1~100 %	10%

### Configuration Command

## 2-6 On-Off Duration

The function of on-off duration setting will be useful if the detector is connected with a module or lighting. The duration determines how long the module/lighting should stay ON. For instance, a value of 100 means the Lamp Module will turn off 100 seconds later after it turns on. This parameter can be configured from 5 to 3600, where the value means how many seconds of delay.

Function	Parameter Number	Size	Range	Default
On-Off Duration	6	1 or 2 (if value > 127)	5~3600 (sec.)	15

### Configuration Command

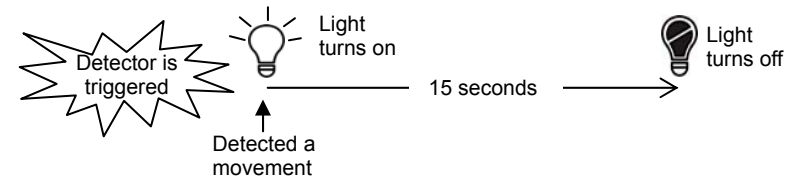

## 3. Advanced Programming

### 3-1 Battery Check Command

The users can also enquire the battery status of the Detector by sending BATTERY\_GET command via Z-Wave Controller. Once the unit receives the command, it will return BATTERY\_REPORT command. If the unit is in low battery status, a Battery\_Level = 255 (0xFF) command will be sent to the Z-Wave Controller.

#### BATTERY\_REPORT Command

**[Command Class Battery, Battery Report, Battery Level = 20%-100%]**

### 3-2 Wakeup Command Class

The detector stays in sleep status for the majority of time in order to conserve battery life. However, it can be woken up by either triggers of movement or by setting WAKE\_UP\_INTERVAL\_SET command via Z-Wave Controller. After the unit wakes up, it will send Wakeup Notification Command to the node ID that requires to be reported. The minimum and maximum wakeup interval is 60 seconds and 194 days respectively. Allowable interval among each wakeup interval is 1 second, such as 60, 61, 62 ....

**Note:** The default value is 1 day, which implies that the detector awakes and sends the Wakeup Notification Command to the set node every day.

## Command Classes

The Motion Detector supports Command Classes including...

\* COMMAND\_CLASS\_ALARM

- \* COMMAND\_CLASS\_BATTERY
- \* COMMAND\_CLASS\_VERSION
- \* COMMAND\_CLASS\_WAKE\_UP\_V2
- \* COMMAND\_CLASS\_ASSOCIATION\_V2
- \* COMMAND\_CLASS\_CONFIGURATION
- \* COMMAND\_CLASS\_SENSOR\_BINARY
- \* COMMAND\_CLASS\_MANUFACTURER\_SPECIFIC
- For Control Other Devices---
- \* COMMAND\_CLASS\_BASIC



## Troubleshooting

Symptom	Possible Cause	Recommendation
LED cannot be displayed	Run out of battery power	Replace a new battery
	Check if reverse battery polarity	Refit the battery with correct polarity
The detector not working	Check if mounting location is proper	Reposition its mounting location
		Remove the source of interference
	Check if the detector is out of order	Do not open the detector; send it to the local retailer.
Two minutes warm up is completed, The detector does not work and LED flashes on & off repeatedly at 2-second intervals	Check if detector is first power up or the detector has executed exclusion or reset procedure	Please carry out inclusion procedure; make sure there are ID codes stored in the detector.

## Specifications

Battery	CR2 3.0V 900mAh Lithium Battery
Operating Range	Minimum 30 meters (free space)
Warm Up Time	About 2 minutes
PIR Detection Coverage	<b>Wall-Mounted:</b> Up to 10m x 110° (at 1.8m mounting height & 25°C)
Operating Frequency	908.42 MHz (US) / 869 MHz (RU)
FCC ID	FU5HSP02

*\*Specifications are subject to change without notice*

A501112129R 2013/09

### Federal Communication Commission Interference Statement

This equipment has been tested and found to comply with the limits for a Class B digital device, pursuant to Part 15 of the FCC Rules. These limits are designed to provide reasonable protection against harmful interference in a residential installation. This equipment generates, uses and can radiate radio frequency energy and, if not installed and used in accordance with the instructions, may cause harmful interference to radio communications. However, there is no guarantee that interference will not occur in a particular installation. If this equipment does cause harmful interference to radio or television reception, which can be determined by turning the equipment off and on, the user is encouraged to try to correct the interference by one of the following measures:

- Reorient or relocate the receiving antenna.
- Increase the separation between the equipment and receiver.
- Connect the equipment into an outlet on a circuit different from that to which the receiver is connected.
- Consult the dealer or an experienced radio/TV technician for help.

This device complies with Part 15 of the FCC Rules. Operation is subject to the following two conditions: (1) This device may not cause harmful interference, and (2) this device must accept any interference received, including interference that may cause undesired operation.

FCC Caution: Any changes or modifications not expressly approved by the party responsible for compliance could void the user's authority to operate this equipment.

This transmitter must not be co-located or operating in conjunction with any other antenna or transmitter.

### WARNING:

Do not dispose of electrical appliances as unsorted municipal waste, use separate collection facilities.

Contact your local government for information regarding the collection systems available.

If electrical appliances are disposed of in landfills or dumps, hazardous substances can leak into the groundwater and get into the food chain, damaging your health and well-being.

When replacing old appliances with new ones, the retailer is legally obligated to take back your old appliance for disposal at least for free of charge.