

FCC ID : FU5FE004

**EUT System: Charging Mode for FE004**  
**<FRONT VIEW>**



**<REAR VIEW>**



FCC ID : FU5FE004  
**EUT Model No. FE004**

Transmitting / Receiving Mode

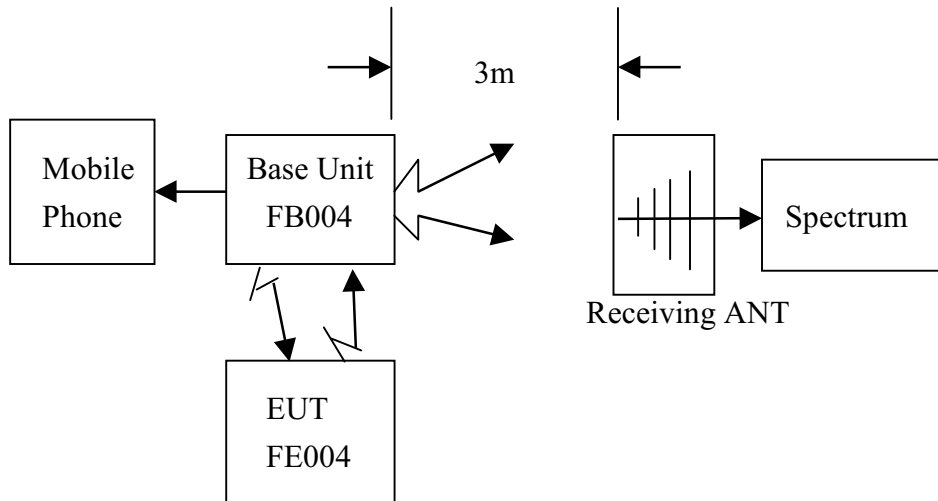

Charging Mode

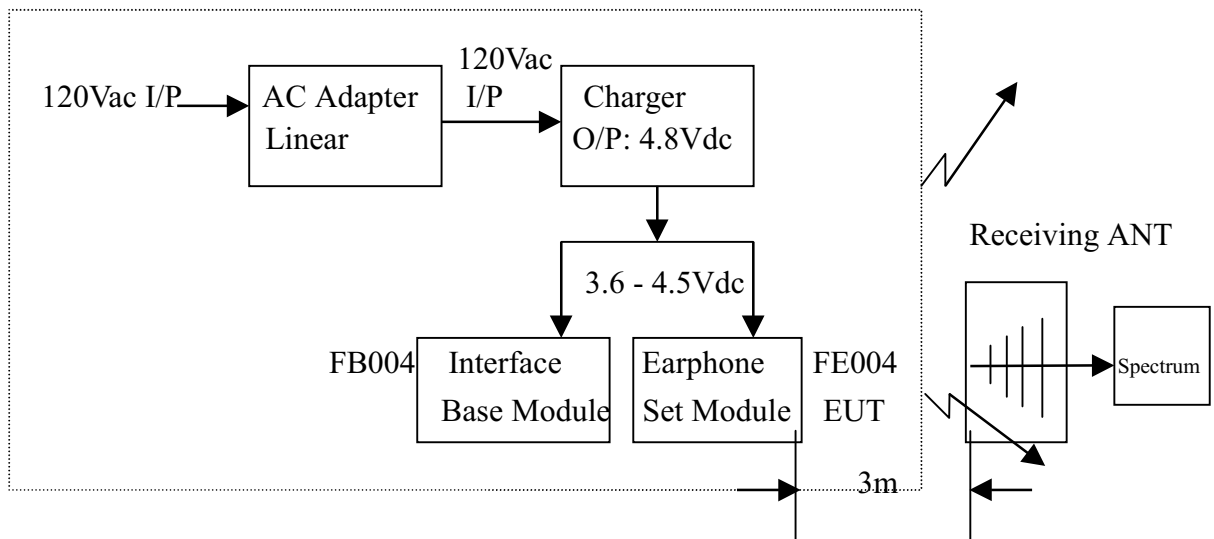

**§ 15.247(c) : Carrier Frequency**

FCC ID : FU5FE004

**EUT Model No. FE004**

In any 100KHz bandwidth outside the frequency band in which the spread spectrum intentional radiator is operating , the radio frequency power that is produced by the intentional radiator shall be at least 20dB

below that in the 100KHz bandwidth within the band that contains the highest level of the desired power , based on either an RF conducted or a radiated measurement.

Test result : top channel – 902 MHz =  $\Delta 31.01 \text{ dB} > 20\text{dB}$

bottom channel – 928MHz =  $\Delta 35.14 \text{ dB} > 20\text{dB}$

Spectrum plot on next page .

FCC ID : FU5FE004

### Spectrum Plot





璋鑫科技有限公司  
PEP Testing Laboratory

Data#: 2237 File#: E2000.em1

Date: 2001-05-28 Time: 15:13:19

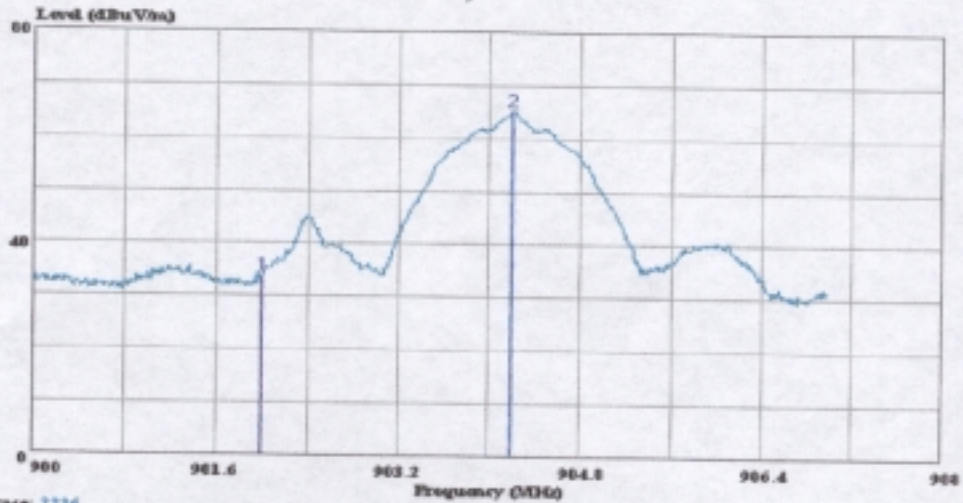

Trace: 2236  
 Site : Chamber No.3(Jason Gong)-Linko Site  
 Condition: 3m ANT.3M(H) HORIZONTAL  
 out : F004U  
 power : AC 115V / 50Hz  
 memo : Peak Value  
       : Channel 1: 902.4MHz  
       : Part No. FE004  
       : Outside Band Frequency

Page: 1

	Freq	Level	Over	Limit	Read	Probe	Cable	Preamp
	MHz	dBuV/m	Limit	Line	Level	Factor	Loss	Factor
			dB	dBuV/m	dBuV	dB	dB	dB
1	902.000	33.88	-----	-----	27.64	23.44	2.80	20.00
2	904.200	58.98	-----	-----	58.65	23.54	2.79	20.00

Read Level = 58.65 - 27.64 = 31.01 dB  
 31.01 ≥ 20dB pass

## § 15.247(d) : Power Spectral Density

FCC ID : FU5FE004

The summary below is the highest power spectral density of the EUT Model No. FE004

RBW = 3KHz    VBW = 10KHz    SWP = 100 sec.

Channel	Frequency (MHz)	S.P. read (dBuV/m)	C.F. (dB)	Level (dBm)	Limit (dBm)	Margin (dBm)
Top	904.287	47.86	6.33	54.19	8	-41.2
Middle	914.312	49.38	6.71	56.09	8	-39.2
Bottom	925.877	46.33	7.16	53.49	8	-41.2

Note:

1. "S.P. read" means spectrum analyzer read power density .
2. "C.F." means correct factor = antenna factor + cable loss – Preamplifier Gain .
3. "Level" means power spectral density .

$$E.R.P. = (E d)^2 / 30G$$

where E (V) = S.P. read + C.F.

d (m) = measurement distance = 3m

G = 1 ( the gain of the transmitting antenna over isotropic antenna )

Example :

If Level = 120 dBuV/m

$$10^{(120/20)} \times 10^{-6} = 1 \text{ V}$$

$$E.R.P. = (1 \times 3)^2 / 30 = 300 \text{ mW} = 10 \text{ Log} (300\text{mW}/1\text{mW}) = 24.77\text{dBm}$$



## Spectrum of Power Spectral Density

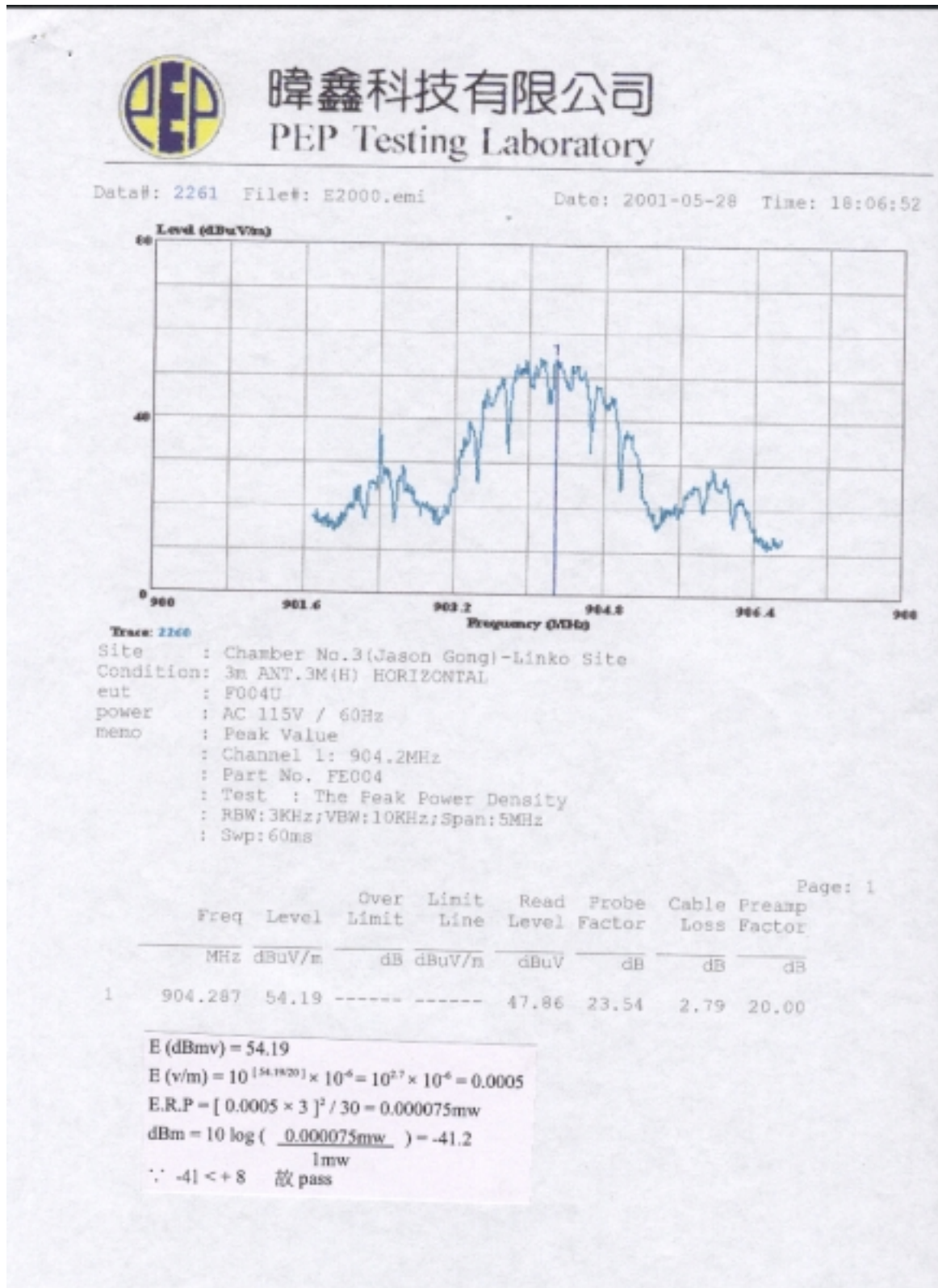



璋鑫科技有限公司  
PEP Testing Laboratory

Data#: 2259 File#: E2000.emi Date: 2001-05-28 Time: 17:54:39

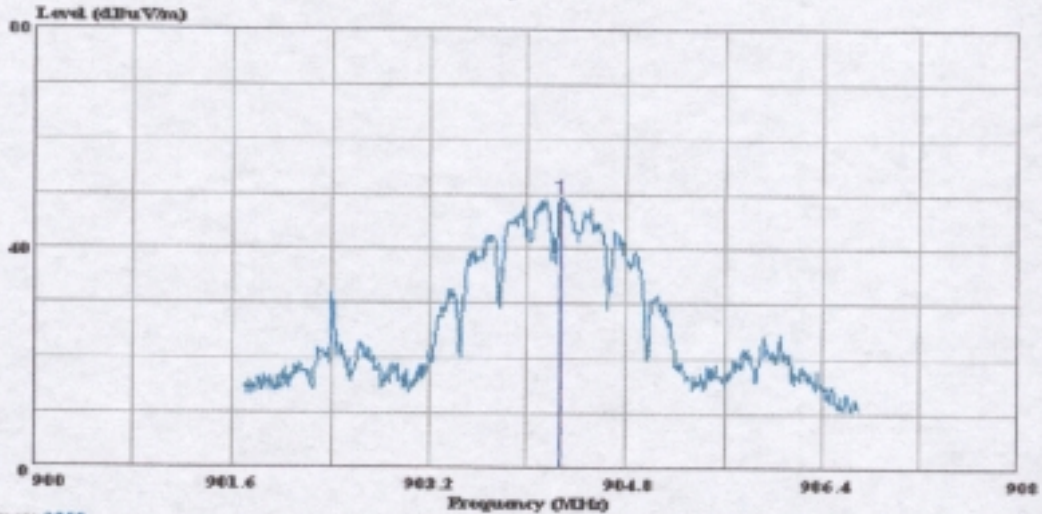

Trace: 2256  
 Site : Chamber No.3 (Jason Gong)-Linko Site  
 Condition: 3m ANT.3M (V) VERTICAL  
 cut : F004U  
 power : AC 115V / 60Hz  
 memo : Peak Value  
       : Channel 1: 904.2MHz  
       : Part No. FE004  
       : Test : The Peak Power Density  
       : RBW:3KHz;VBW:10KHz;Span:5MHz  
       : Swp:60ms

Page: 1

	Freq	Level	Over	Limit	Read	Probe	Cable	Preamp
	MHz	dBuV/m	Limit	Line	Level	Factor	Loss	Factor
			dB	dBuV/m	dBuV	dB	dB	dB
1	904.267	49.31	-----	-----	42.98	23.54	2.79	20.00

$E \text{ (dBmV)} = 54.19$   
 $E \text{ (v/m)} = 10^{(49.31/20)} \times 10^{-6} = 10^{2.5} \times 10^{-6} = 0.00032$   
 $E.R.P = [0.00032 \times 3]^2 / 30 = 0.000031 \text{mw}$   
 $\text{dBm} = 10 \log \left( \frac{0.000031 \text{mw}}{1 \text{mw}} \right) = -45.1$   
 $\therefore -45.1 < +8$  故 pass





# 璋鑫科技有限公司

## PEP Testing Laboratory

Data#: 2263 File#: E2000.emi

Date: 2001-05-28 Time: 18:15:49

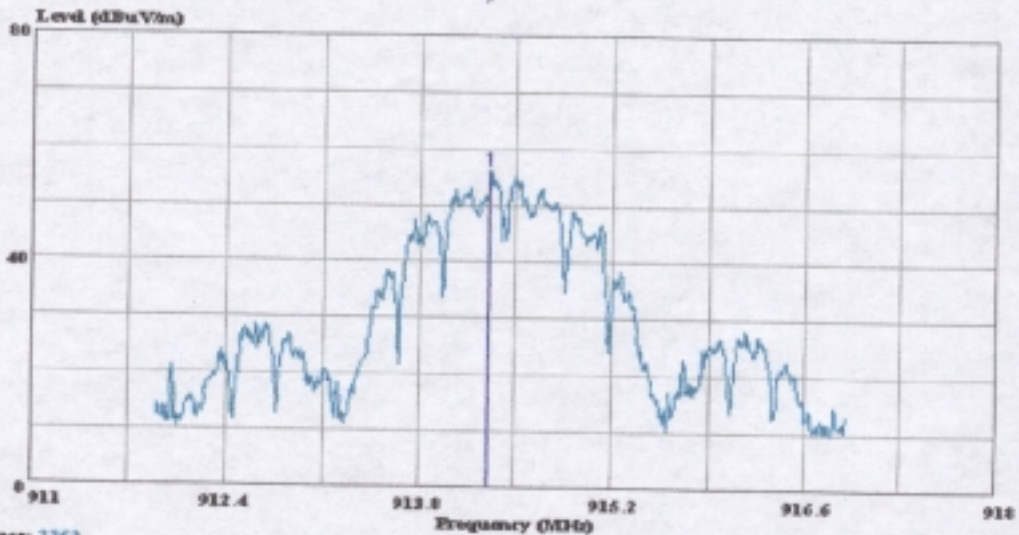

Trace: 2262  
 Site : Chamber No.3(Jason Gong)-Linko Site  
 Condition: 3m ANT.3M(H) HORIZONTAL  
 cut : F004U  
 power : AC 115V / 60Hz  
 memo : Peak Value  
       : Channel 1: 914.4MHz  
       : Part No. FE004  
       : Test : The Peak Power Density  
       : RBW:3KHz;VBW:10KHz;Span:5MHz  
       : Swp:60ms

Page: 1

Freq	Level	Over Limit	Limit Line	Read Level	Probe Factor	Cable Loss	Preamp Factor
MHz	dBuV/m	dB	dBuV/m	dBuV	dB	dB	dB
1 914.312	56.09	-----	-----	49.38	23.93	2.78	20.00

E (dBm) = 56.09  
 $E (v/m) = 10^{[56.09/20]} \times 10^{-6} = 10^{2.8} \times 10^{-6} = 0.00063$   
 $E.R.P = [0.00063 \times 3]^2 / 30 = 0.00012mw$   
 $dBm = 10 \log ( \frac{0.00012mw}{1mw} ) = -39.2$   
 $\therefore -39.2 < +8$  故 pass



璋鑫科技有限公司  
PEP Testing Laboratory

Data#: 2265 File#: E2000.emi

Date: 2001-05-28 Time: 18:22:22

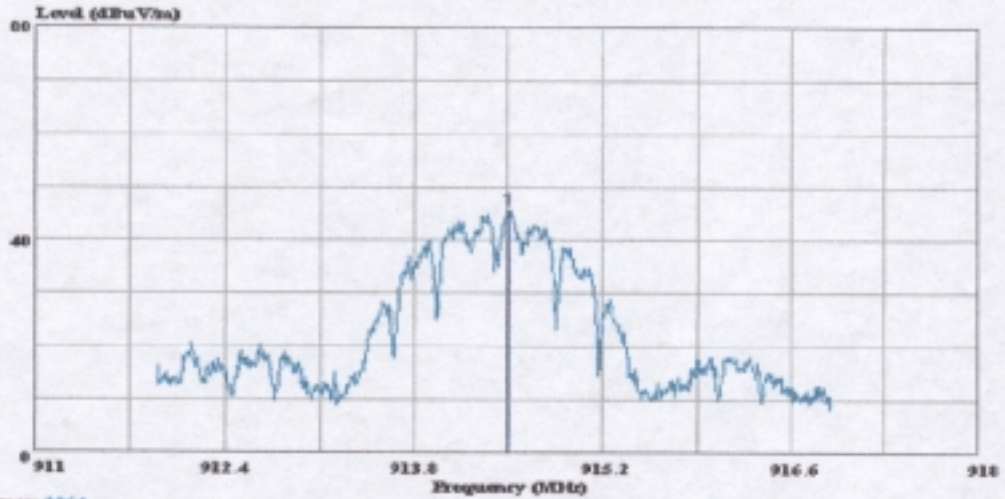

Trace: 2264

Site : Chamber No.3 (Jason Gong) - Linko Site  
 Condition: 3m ANT.3M(V) VERTICAL  
 eut : F004U  
 power : AC 115V / 60Hz  
 memo : Peak Value  
 : Channel 1: 914.4MHz  
 : Part No. FE004  
 : Test : The Peak Power Density  
 : RBW:3KHz;VBW:10KHz;Span:5MHz  
 : Swp:60ms

Page: 1

	Freq	Level	Over	Limit	Read	Probe	Cable	Preamp
	MHz	dBuV/m	Limit	Line	Level	Factor	Loss	Factor
			dB	dBuV/m	dBuV	dB	dB	dB
1	914.512	45.58	-----	-----	38.86	23.94	2.78	20.00

E (dBmv) = 45.58  
 $E (v/m) = 10^{(45.58/20)} \times 10^{-6} = 10^{2.279} \times 10^{-6} = 0.0002$   
 $E.R.P = [0.0002 \times 3]^2 / 30 = 0.000012mw$   
 $dBm = 10 \log ( \frac{0.000012mw}{1mw} ) = -49.2$   
 $\therefore -49.2 < +8$  故 pass





暉鑫科技有限公司  
PEP Testing Laboratory

Data#: 2267 File#: E2000.emi

Date: 2001-05-28 Time: 18:37:13

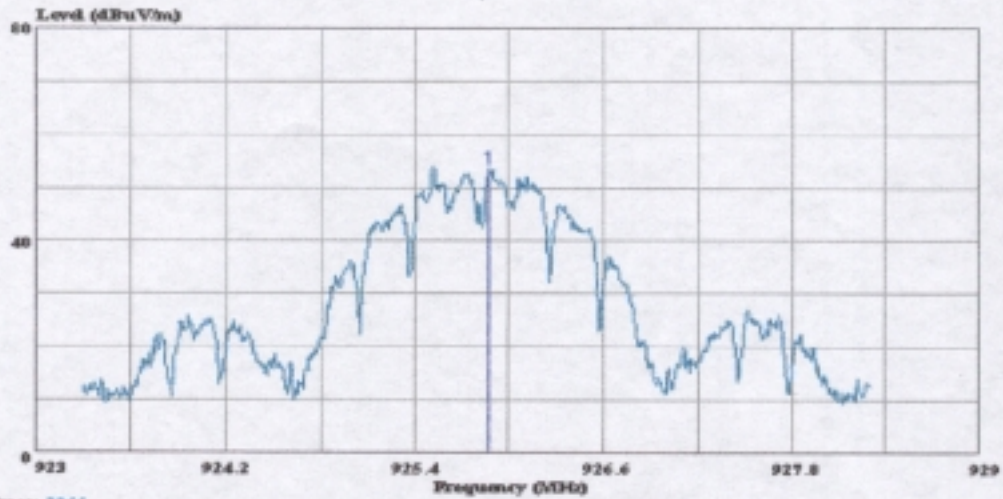

Trace: 2266

Site : Chamber No.3(Jason Gong)-Linko Site  
 Condition: 3m ANT,3M(H) HORIZONTAL  
 eat : F004U  
 power : AC 115V / 60Hz  
 memo : Peak Value  
 : Channel 20: 925.8MHz  
 : Part No. FE004  
 : Test : The Peak Power Density  
 : RBW:3KHz;VBW:10KHz;Span:5MHz  
 : Swp:60ms

Page: 1

	Freq	Level	Over	Limit	Read	Probe	Cable	Prearp
	MHz	dBuV/m	Limit	Line	Level	Factor	Loss	Factor
			dB	dBuV/m	dBuV	dB	dB	dB
1	925.877	53.49	-----	-----	46.33	24.39	2.77	20.00

E (dBmv) = 53.49  
 $E (v/m) = 10^{(53.49/20)} \times 10^{-6} = 10^{2.67} \times 10^{-6} = 0.0005$   
 $E.R.P = [0.0005 \times 3]^2 / 30 = 0.000075mw$   
 $dBm = 10 \log ( \frac{0.000075mw}{1mw} ) = -41.2$   
 $\therefore -41.2 < +8$  故 pass



璋鑫科技有限公司  
PEP Testing Laboratory

Data#: 2269 File#: E2000.emi Date: 2001-05-28 Time: 18:44:51

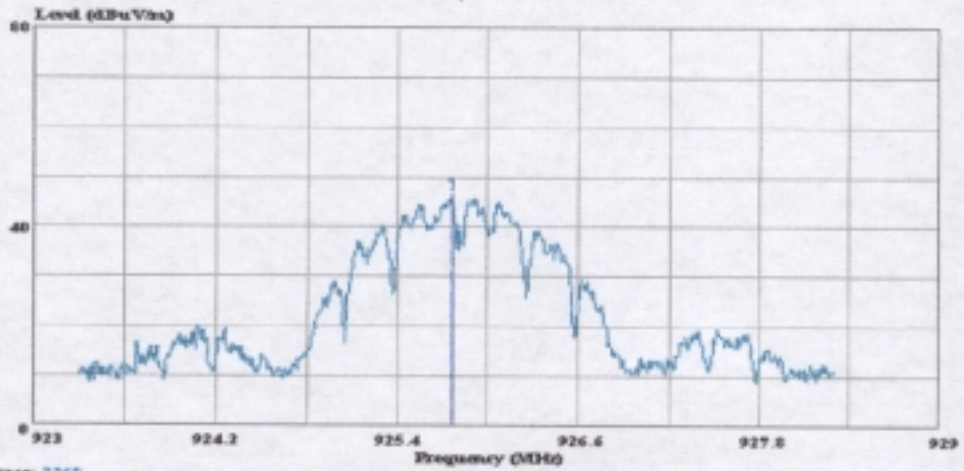

Trace: 2268  
 Site : Chamber No.3(Jason Gong)-Linko Site  
 Condition: 3m ANT.3M(V) VERTICAL  
 eut : F004U  
 power : AC 115V / 60Hz  
 memo : Peak Value  
       : Channel 1: 925.8MHz  
       : Part No. FE004  
       : Test : The Peak Power Density  
       : RBW:3KHz;VBW:10KHz;Span:5MHz  
       : Swp:60ms

Page: 1

	Freq	Level	Over	Limit	Read	Probe	Cable	Preamp
	MHz	dBuV/m	Limit	Line	Level	Factor	Loss	Factor
			dB	dBuV/m	dBuV	dB	dB	dB
1	925.767	46.45	-----	-----	39.30	24.38	2.77	20.00

$E \text{ (dBmv)} = 46.45$   
 $E \text{ (v/m)} = 10^{(46.45/20)} \times 10^{-6} = 10^{2.3} \times 10^{-6} = 0.0002$   
 $E.R.P = [0.0002 \times 3]^2 / 30 = 0.000012\text{mw}$   
 $\text{dBm} = 10 \log \left( \frac{0.000012\text{mw}}{1\text{mw}} \right) = -49.2$   
 $\therefore -49.2 < +8$  故 pass

## § 15.247(e) :Processing Gain

### 7.1 Test Condition & Setup

#### A, Bit Error Rate (Pe)

The subject RF device Earphone set model FE004 is digital modulation by Differential Phase Shift Keying (DPSK), the DPSK can use its previous waveform as the phase reference for demodulation and thus requires no coherent detection, which greatly simplifies the receiver structure but with some Bit Error Rate (BER) degradation because of noisy phase reference. There is tradeoff between system complexity and system performance. In order to drive the DPSK error probability, we observe that DPSK using differential coding, we observe that DPSK using differential coding is essentially an orthogonal signal scheme. A binary 1 is transmitted a sequence of two pulse (P,P) or (-P,-P) (-P, P) To seconds (no transition). Similarly, a binary 0 is transmitted by a sequence of two plus (P,-P) or (-P, P) over 2 TO seconds (transition). Either of the pulse sequences used for binary 1 is orthogonal to either of the pulse sequences used for binary 0. Because no local carrier is generated for demodulation, the detection is noncoherent, with an effective pulse energy equal to  $2E_p$  (twice the energy of pulse P). The actual energy transmitted per digit only  $E_p$ , however, the same as in noncoherent FSK, Consequently, the performance of DPSK is 3 dB superior to that of noncoherent FSK, We can write  $P_e$  for DPSK as:

The major component inside the subjective device are supplied by Rockwell, Included RF block transmitter (RF105), Receiver (RF 100), and Base band block ASIC (c8502-13), CODEC (10497-14), above 4 IC chips are affected the processing gain as following:

$$J/S = (W/R_b) E_b/N_0 \text{ [without CODING]}$$

Where: W= Spread Chip Rate = Required Transmitted Base band Bandwidth.

$R_b$  = Information Data Rate

$E_b/N_0$  = Require Energy per Bit over noise Spectral Density for a Specific Bit Error Probability.

The subjective Device Information Data Rate are 80k and the Spread Chip Rate are 960k So the processing gain ( $10 \log w/R_b$ ) at least 10.79dB (without Coding).

The ASIC (c8502-13) and CODEC (10497-14) these two chip included the coding function, So, it is great improve the processing gain and also improve the J/S ratio.

The Engineer work for Rockwell System in Taiwan had pass us the information about the probability of error rate ( $P_e$ ) must be lower than 0.001 That the system performance will satisfy for communication between Handset and Base station.

Why we need the  $P_e$  lower than 0.001, the Rockwell Semiconductor System is not explained, Since it relative with ASIC and Codec, it is confidential area that Rockwell is not allow to disdouse to the public. When  $P_e = 0.001$  and then Signal to Noise Ratio  $(S/N) = 6.2194 = 7.9\text{dB}$ .



## B. Jamming Margin Method

The Rockwell semiconductor System give us a software operated in the personal computer. And use the computer series port COM1 and COM2 connect headset and interlace module than we can measure the Bit Error Rate.

Using this software we can perform Jamming Margin method testing, The test consists of stepping

a signal generator in 50KHz increments across the pass band of the system (up to 960KHz away in RI's DCT ). At each point, the generator level required to produce the recommend Bit ERROR Rate (BER =  $10e - 3$ ) is recorded. This level is the jamming level. The maximum implementation loss a system can claim in calculating processing gain is 2 dB.

The equation to calculate the processing gain (Gp) is the following :

$$G_p = (S/N) + M_j + L_{sys}$$

$$G_p = 8 \text{ dB} + M_j + 2 \text{ dB}$$

FCC regulation section 15.247(e) require the processing gain of a direct sequence system shall be at least 10dB, when Gp must be greater than 10dB, then the Jammer must be greater than 0d.

The processing gain may be measured using the CW jamming margin method. The Jammer to Signal (J/S) ratio is then calculated Discard the worst 20% of the J/S data points.

1. For avoid the headset and interface module station are situation, so, the BUT were in low power mode.
2. The signal generator was selected in interference band, using this software we can perform Jamming Margin method testing, the test consists of stepping a signal generator is 50KHz increments across the pass band of the System (up to 960 KM' away in RI's EUT) So, the BER will keep in 0.1%.

7.2 Test Instruments Configuration

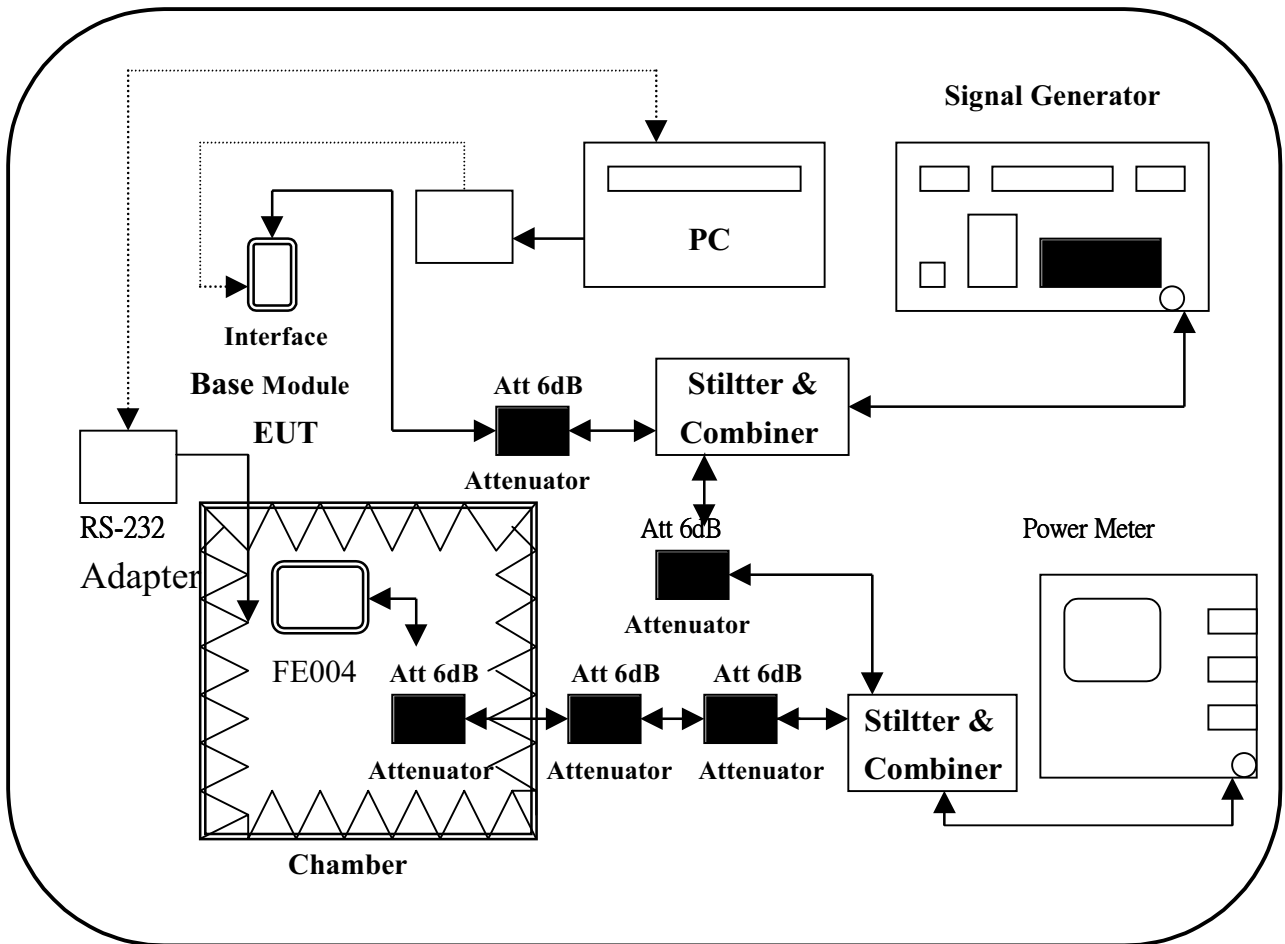

P.S: A serial port from computer to control the EUT at power output and channel number.  
 Test Configuration of processing gain for Earphone set

### 7.3 Test Procedure

Measure the high power output of the channel 11 of the headset while the headset is in “Transmit-Only-Test” and the whole circuit is as same as attachment. What we measure in this step is “S”.

Change to the “BER Test“ program. Increase the RF output of the signal generator till the BER is close to the 0.1%but under 0.1%.

Stop the program and turn off the interface module, headset then record the highest point of the spectrum. What we measure in this step is ”J” .

Star the Program again and test the next point.

## 7.4 Test Result of Processing Gain

[ Processing Gain for Channel 11 : 914.600 to 915.950 MHz ]

Jammer Frequency (MHz)	S (dBm)	J (dBm)	Mj (J/S)	Process Gain (dB)
914.600	-52.80	-45.88	6.92	16.82
914.650	-52.80	-49.85	2.95	12.85
914.700	-52.80	-50.15	2.65	12.55
914.750	-52.80	-49.74	3.06	12.96
914.800	-52.80	-49.48	3.32	13.22
914.850	-52.80	-51.30	1.50	11.40
914.900	-52.80	-51.18	1.62	11.52
914.950	-52.80	-44.00	8.80	18.70
915.000	-52.80	-50.63	2.17	12.07
915.050	-52.80	-45.60	7.20	17.10
915.100	-52.80	-49.72	3.08	12.98
915.150	-52.80	-49.70	3.10	13.00
915.200	-52.80	-46.07	6.73	16.63
915.250	-52.80	-45.05	7.75	17.65
915.300	-52.80	-45.06	7.74	17.64
915.350	-52.80	-43.00	9.80	19.70
915.400	-52.80	-41.00	11.80	21.70
915.450	-52.80	-49.85	2.95	12.85
915.500	-52.80	-49.85	2.95	12.85
915.550	-52.80	-47.52	5.28	15.18
915.600	-52.80	-42.55	10.25	20.15
915.650	-52.80	-45.21	7.59	17.49
915.700	-52.80	-45.20	7.60	17.50
915.750	-52.80	-46.20	6.60	16.50
915.800	-52.80	-42.85	9.95	19.85
915.850	-52.80	-44.28	8.52	18.42
915.900	-52.80	-44.19	8.61	18.51
915.950	-52.80	-41.88	10.92	20.82

[ Processing Gain for Channel 11 : 916.000 to 916.600 MHz ]

Jammer Frequency (MHz)	S (dBm)	J (dBm)	Mj (J/S)	Process Gain (dB)
916.000	-52.80	-41.88	10.92	20.82
916.050	-52.80	-41.75	11.05	20.95
916.100	-52.80	-41.88	10.92	20.82
916.150	-52.80	-34.84	17.96	27.86
916.200	-52.80	-39.85	12.95	22.85
916.250	-52.80	-34.85	17.95	27.85
916.300	-52.80	-36.26	16.54	26.44
916.350	-52.80	-37.47	15.33	25.23
916.400	-52.80	-32.64	20.16	30.06
916.450	-52.80	-32.74	20.06	29.96
916.500	-52.80	-30.35	22.45	32.35
916.550	-52.80	-30.40	22.40	32.30
916.600	-52.80	-30.00	22.80	32.70

Test Result : Processing Gain = 12.98dB

$$\begin{aligned} \text{Note : } 1. \text{GP} &= (\text{S}/\text{No}) + \text{Mj} + \text{Lsys} \\ &= 7.9\text{dB} + \text{Mj} + 2\text{dB} \end{aligned}$$

2. S = Signal Level

3. J = Signal Generator RF Output



### VIII. List of Test Instruments

<b>Emission</b>	<b>Instrument</b>	<b>Model No.</b>	<b>Serial No.</b>	<b>Next Cal. Date</b>	<b>Cal. Interval</b>
<b>Conduction (No.2)</b>	HP Spectrum	8591A	3225A03039	May 19, 2002	1 Year
	R & S LISN	ESH2-Z5	831886/00A	Jan. 30, 2002	1 Year
	Kyoritsu LISN	KNW-242	8-837-7	N/A	N/A
	RF Cable	No.4	N/A	Feb. 20, 2002	1 Year
<b>Radiation (OP No.2)</b>	R & S Receiver	ESVS10	826148/012	Apr. 17, 2001	1 Year
	Advantest Spectrum	R3261C	81720343	N/A	N/A
	Schaffner Pre-Amp.	CPA-9232	1012	Feb. 25, 2002	1 Year
	R & S Pre-Amp.	ESMI-Z7	612278/011	Jun. 01, 2001	1 Year
	EMCO Antenna	3142B	9909-1420	Jun. 01, 2001	1 Year
	COM-Power Horn Ant.	AH-118	10056	Aug. 24, 2001	1 Year
	RF Cable	No.1	N/A	Feb. 20, 2002	1 Year
	SCHWARZBECK Precision Dipole Ant.	VHAP	970+971 953+954	Jun. 27, 2003	3 Year
	R & S Signal Generator	SMY02	839846/038	Jan. 30, 2002	1 Year