

***EXHIBIT B***

***Test Report***

# MEASUREMENT REPORT of DIGITALKI WIRELESS HANDSFREE KIT FOR HEADSET

**Applicant** : EVERSPRING INDUSTRY CO., LTD.  
**Model No.** : FE001  
**EUT** : D.S. S. Wireless Handfree Kit for Headset  
**FCC ID** : FU5FE001  
**Report No.** : E2415607

Test by :

*Training Research Co., Ltd.*

**TEL : 886-2-26935155      FAX : 886-2-26934440**

2, Lane 194, Huan-Ho Street, Hsichih, Taipei Hsien 221, Taiwan, R.O.C.

# CERTIFICATION

**We here by verify that:**

The test data, data evaluation, test procedures and equipment configurations shown in this report were made mainly in accordance with the procedures given in ANSI C63.4 (1992) as a reference. All test were conducted by *Training Research Co., Ltd.*, 2, Lane 194, Huan-Ho Street, Hsichih, Taipei Hsien 221, Taiwan, R.O.C. Also, we attest to the accuracy of each.

We further submit that the energy emitted by the sample EUT tested as described in the report is **in compliance with** the technical requirements set forth in the FCC Rules Part 15 Subpart C Section 15.233.

**Applicant** : EVERSPRING INDUSTRY CO., LTD.  
**Model No.** : FE001  
**EUT** : D.S. S. Wireless Handfree Kit for Headset  
**FCC ID** : FU5FE001  
**Report No.** : E2415607  
**Test Date** : January 8, 2001

Prepared by:

  
Jack Tsai

Approved by:

  
Frank Tsai

Test by :

***Training Research Co., Ltd.***

TEL: 886-2-26935155

FAX: 886-2-26934440

2, Lane 194, Huan-Ho Street, Hsichih, Taipei Hsien 221, Taiwan, R.O.C.

## *Tables of Contents*

<b>I. GENERAL</b> .....	5
1.1 Introduction .....	5
1.2 Description of EUT .....	5
1.3 Description of Support Equipment .....	5
1.4 Configuration of System Under Test .....	6
1.5 Verify the Frequency and Channel .....	7
1.5.1 Verify the Frequency Pairs .....	7
1.6 Test Procedure .....	8
1.7 Location of the Test Site .....	8
1.8 General Test Condition .....	8
<b>II. Section 15.207: Power line conducted emissions for AC powered units</b> .....	9
2.1 Test Condition & Setup .....	9
2.2 List of Test Instruments .....	9
2.3 Test Configuration .....	10
2.4 Test Result of Conducted Emissions .....	11
2.4.1 Base Station Transmit Only .....	11
<b>III. Section 15.247(a)(2): Bandwidth for direct sequence system</b> .....	12
3.1 Test Condition & Setup .....	12
3.2 Test Instruments Configuration .....	12
3.3 List of Test Instruments .....	12
3.4 Test Result of Bandwidth .....	13
<b>IV. Section 15.247(a) (2) : Power Output</b> .....	16
4.1 Test Condition & Setup .....	16
4.2 List of Test Instruments .....	17
4.3 Test Result of Fundamental Emission .....	18

**V. Section 15.247(c) (2) : Spurious Emissions (Radiated)** ..... 19

- 5.1 Test Condition & Setup ..... 19
- 5.2 List of Test Instruments ..... 20
  - 5.2.1 Duty Cycle Factor Measurement ..... 20
- 5.3 Test Instruments Configuration ..... 22
- 5.4 Test Result of Second Harmonic ..... 23
- 5.5 Test Result of Spurious Radiated Emissions ..... 24
  - 5.5.1 Base and Handset Station Transmit Only ..... 24

**VI. Section 15.247(d) : Power Spectral Density** ..... 36

- 6.1 Test Condition & Setup ..... 36
- 6.2 Test Instruments Configuration ..... 37
- 6.3 List of Test Instruments..... 37
- 6.4 Required of Carrier Frequency ..... 38
- 6.5 Test Result of Power Spectral Density ..... 40

**VII. Section 15.247(e): Processing Gain** ..... 43

- 7.1 Test Condition & Setup ..... 43
- 7.2 Test Instruments Configuration ..... 45
- 7.3 List of Test Instruments ..... 46
- 7.4 Test Procedure ..... 46
- 7.5 Test Result of Processing Gain ..... 47

**Appendix A : Set Up Procedure** ..... 49

**Appendix B : Part15.203** ..... 50

## **. GENERAL**

### **1.1 Introduction**

The following measurement report is submitted on behalf of Applicant in support of a Cordless Telephone certification in accordance with Part 2 Subpart J and Part 15 Subpart A and C of the Commission's Rules and Regulations.

### **1.2 Description of EUT**

**EUT** : D. S. S. Wireless Handfree Kit for Headset  
**Model No.** : FE001  
**FCC ID** : FU5FE001  
**Frequency Range** : 904.20 – 925.80 MHz  
**Support Channel** : 20 Channel  
**Modulation Skill** : TDMA / Spread spectrum  
**Power Type** : Powered by 120Vac 60 Hz, 9W / 12Vdc 300mA  
3.6 V / 70mAh  
**Power Cord** : Non-shielded , 185 cm long, No ferrite bead  
**Applicant** : EVERSPRING INDUSTRY CO., LTD.  
2F, No. 3, Alley 6, Lane 118, Chung Yang Road, Sec. 1,  
Tu-Chen Hsien, Taipei Hsien, Taiwan

### **1.3 Description of Support Equipment**

In order to construct the minimum testing, following equipment were used as the support units.

**Notebook** : IBM Think Pad X20  
**Type No.** : 2662-11T  
**Serial No.** : FX-11922 00/09  
**Power Type** : Auto witching  
**Power Core** : Shielded, 180 cm long, Plastic hoods, ferrite bead  
**FCC ID** : Doc approved.

### 1.4 Configuration of System Under Test

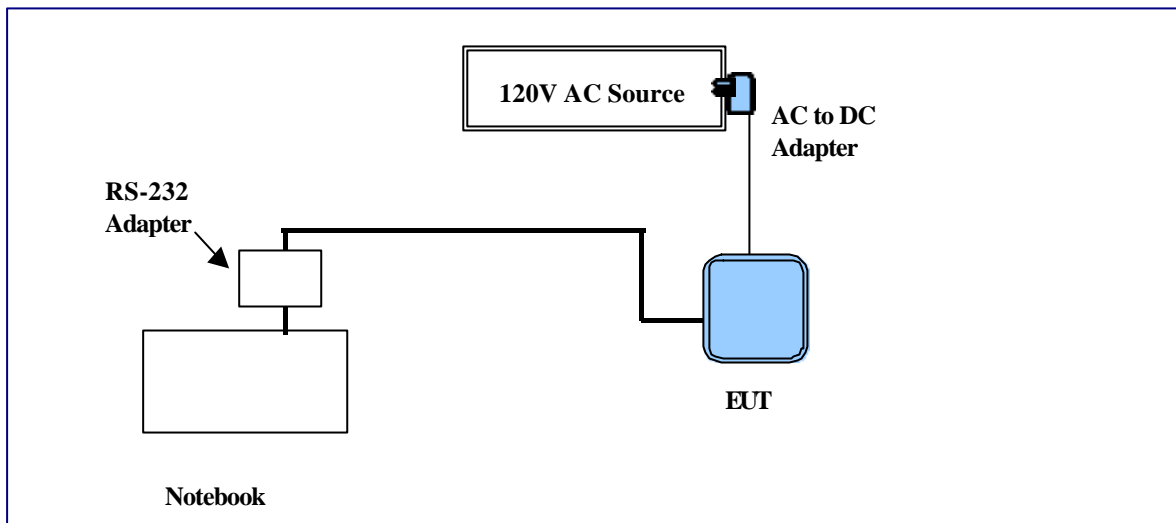

Fig. 1 Configuration of system under test

The tests below are run with the EUT transmitter set at high power in TDD mode .A serial port from a computer to the EUT. EUT is needed to force selection of output power level and channel number.

The setting up procedure was recorded in Appendix A.

**1.5 Verify the Frequency and Channel**

**1.5.1 Verify the Frequency Pairs**

Channel	Frequency (MHz)	Channel	Frequency (MHz)
1	904.20	11	915.60
2	904.80	12	916.80
3	906.00	13	918.00
4	907.20	14	919.20
5	908.40	15	920.40
6	909.60	16	921.60
7	910.80	17	922.80
8	912.00	18	924.00
9	913.20	19	925.20
10	914.40	20	925.80

Note:

1. This is for sure that all frequencies are in 902 MHz to 928 MHz.
2. Section 15.31(m): Measurements on intentional radiators or receivers shall be performed at three frequencies for operating frequency range over 10 MHz. (The locations of these frequencies one near the top, one near the middle and one near the bottom.)
3. After test, the EUT operating frequencies are in 904.20MHz to 925.80MHz. So all the items as followed in testing report are need to test these three frequencies: top: channel 1, middle: channel 11, bottom: channel 20.



## **1.6 Test Procedure**

All measurements contained in this report were performed mainly according to the techniques described in ANSI C63.4 (1992) and the pre-setup was written on Appendix A, the detail setup was written on each test item.

## **1.7 Location of the Test Site**

The radiated emissions measurements required by the rules were performed on the **three-meter, Anechoic Chamber (Registration Number: 93906)** maintained by *Training Research Co., Ltd.* 1F., No. 2, Lane 194, Huan-Ho Street, Hsichih, Taipei Hsien 221, Taiwan, R.O.C. Complete description and measurement data have been placed on file with the commission. The conducted power line emissions tests and other test items were performed in a shielded enclosure also located at Training Research Co., Ltd. 1F., No. 2, Lane 194, Huan-Ho Street, Hsichih, Taipei Hsien 221, Taiwan, R.O.C. *Training Research Co., Ltd.* is listed by the FCC as a facility available to do measurement work for others on a contract basis.

## **1.8 General Test Condition**

The conditions under which the EUT operates were varied to determine their effect on the equipment's emission characteristics. The final configuration of the test system and the mode of operation used during these tests were chosen as that which produced the highest emission levels. However, only those conditions, which the EUT was considered likely to encounter in normal use were investigated.

In test, the headset is tested. They were set in high power and continuously transmitting mode that controlled by computer. The ch01, ch11 and ch20 of interface module and headset were all tested. The setting up procedure is recorded on Appendix A.

**Section 15.207: Power Line Conducted Emissions for AC Powered Units**

**2.1 Test Condition & Setup**

The power line conducted emission measurements were performed in an anechoic chamber. The EUT was assembled on a wooden table, which is 80 centimeters high, was placed 40 centimeters from the backwall and at least 1 meter from the sidewall.

Power was fed to the EUT from the public utility power grid through a line filter and Line Impedance Stabilization Networks (LISNs). The LISN housing, measuring instrumentation case, ground plane, etc., were electrically bonded together at the same RF potential. The Spectrum analyzer (or EMI receiver) was connected to the AC line through an isolation transformer. The 50-ohm output of the LISN was connected to the spectrum analyzer directly. Conducted emission levels were in the CISPER quasi-peak detection mode. The analyzer's 6 dB bandwidth was set to 9 KHz. No post-detector video filter was used.

The spectrum was scanned from 450 KHz to 30 MHz. The physical arrangement of the test system and associated cabling was varied (within the scope of arrangements likely to be encountered in actual use) to determine the effect on the unit's emanations in amplitude and frequency. All spurious emission frequencies were observed. The highest emission amplitudes relative to the appropriate limit were measured and have been recorded in paragraph 2.4.

There are tree test condition apply in this test item, the test procedure description as the following :

1. Idle state (Charging mode)

The setting up procedure is recorded on Appendix A.

**2.2 List of Test Instruments**

Instrument Name	Model No.	Brand	Serial No.	Last time	Next time
EMI Receiver	8546A	H P	3520A00242	10/18/00	10/18/01
RF Filter Section	85460A	H P	3448A00217	10/18/00	10/18/01
LISN (EUT)	LISN-01	TRC	9912-03,04	12/09/00	12/09/01
LISN (Support E.)	LISN-01	TRC	9912-05	01/04/00	01/04/01
Switch/Control Unit (< 30MHz)	3488A	HP	N/A	11/20/00	11/20/01
Auto Switch Box (< 30MHz)	ASB-01	TRC	9904-01	11/20/00	11/20/01

2.3 Test configuration

*Conducted Emissions Test Placement*



**2.4 Test Result of Conducted Emissions**

**2.4.1 Headset Charging only**

The following table shows a summary of the highest emissions of power line conducted emissions on the HOT and NATURAL conductors of the EUT power cord.

**Table 1 Power Line Conducted Emissions (Charging)**

<i>Power Connected Emissions</i>			<i>FCC Class B</i>	
<i>Conductor</i>	<i>Frequency (KHz)</i>	<i>Peak Amplitude (dB μV)</i>	<i>Limit (dB μV)</i>	<i>Margin (dB)</i>
Line 1	455.00	34.67	48.00	-13.33
	467.00	34.68	48.00	-13.32
	505.00	34.57	48.00	-13.43
	518.00	34.92	48.00	-13.08
	530.00	35.89	48.00	-12.11
	564.00	35.99	48.00	-12.01
	593.00	35.65	48.00	-12.35
	612.00	32.60	48.00	-15.40
	641.00	34.91	48.00	-13.09
	697.00	32.41	48.00	-15.59
LINE 2	452.00	38.33	48.00	-9.67
	467.00	37.95	48.00	-10.05
	493.00	38.39	48.00	-9.61
	508.00	38.24	48.00	-9.76
	521.00	38.67	48.00	-9.33
	534.00	38.60	48.00	-9.40
	549.00	38.96	48.00	-9.04
	568.00	38.83	48.00	-9.17
	597.00	39.28	48.00	-8.72
	620.00	38.17	48.00	-9.83

NOTE:

1. Margin = Peak Amplitude – Limit
2. A "+" sign in the margin column means the emission is OVER the Class B Limit and  
 "-" sign of means UNDER the Class B Limit.

## Section 15.247(a)(2): Bandwidth for Direct Sequence System

### 3.1 Test Condition & Setup

The transmitter bandwidth measurements were performed in a shielded enclosure. The EUT was placed on a wooded table, which is 0.8 meters height. The EUT was set to transmit continuously. Various channels were also investigated to find the maximum occupied bandwidth. The minimum 6 dB bandwidth shall be at least 500 KHz.

Make the measurement with the spectrum analyzer's resolution bandwidth (RBW) = 100 KHz. Set the span >> RBW. The detector function was set to peak and hold mode to clearly observe the components.

Setting up procedure is written on Appendix A.

### 3.2 Test Instruments Configuration

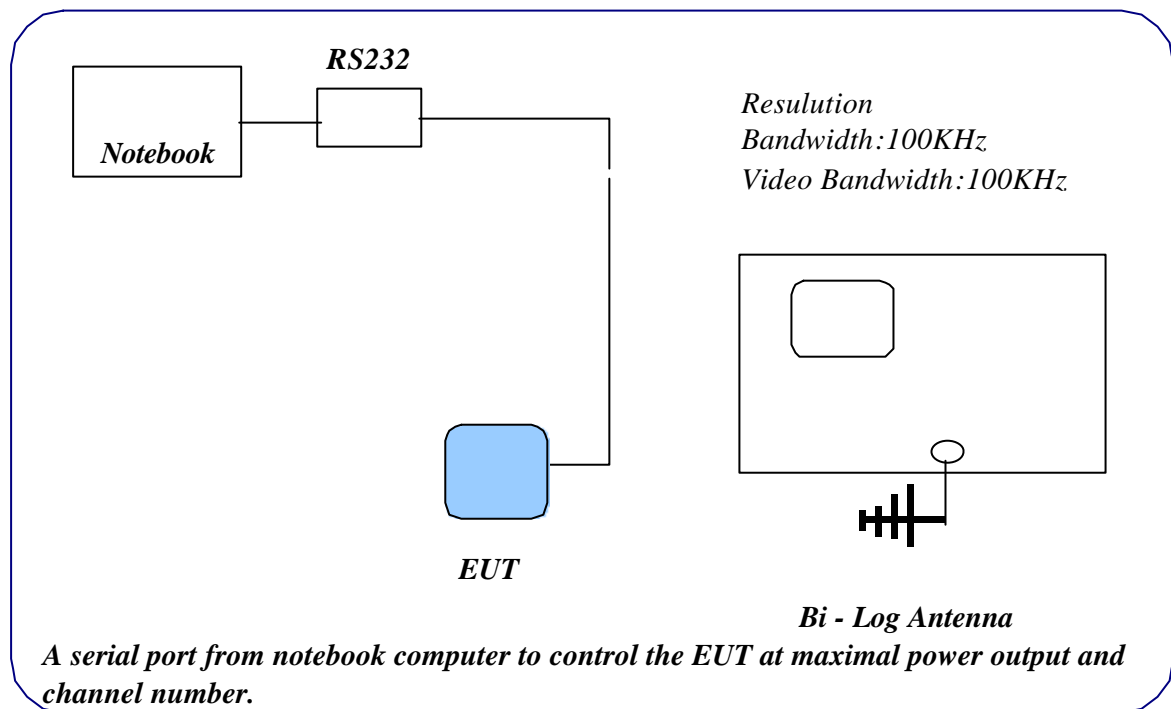

Fig 10. Test Configuration of bandwidth for direct sequence system

### 3.3 List of Test Instruments

Instrument Name	Model No.	Brand	Serial No.	Last time	Next time
EMI Receiver	8546A	H P	3520A00242	10/18/00	10/18/01
RF Filter Section	85460A	H P	3448A00217	10/18/00	10/18/01
Bi-log Antenna	CBL6141A	Schaffner	4151	07/04/00	07/04/01

### **3.4 Test Result of Bandwidth**

#### **Bandwidth of Channel 1**

Bandwidth : 575 kHz

The min. 6 dB BW at least : 500 kHz

#### **Bandwidth of Channel 11**

Bandwidth : 588 kHz

The min. 6 dB BW at least : 500 kHz

#### **Bandwidth of Channel 20**

Bandwidth : 588 kHz

The min. 6 dB BW at least : 500 KHz

Note:

1. The data in the above table are summarize the following attachment spectrum analyzer hard copy.
2. The attachment follow by next page.

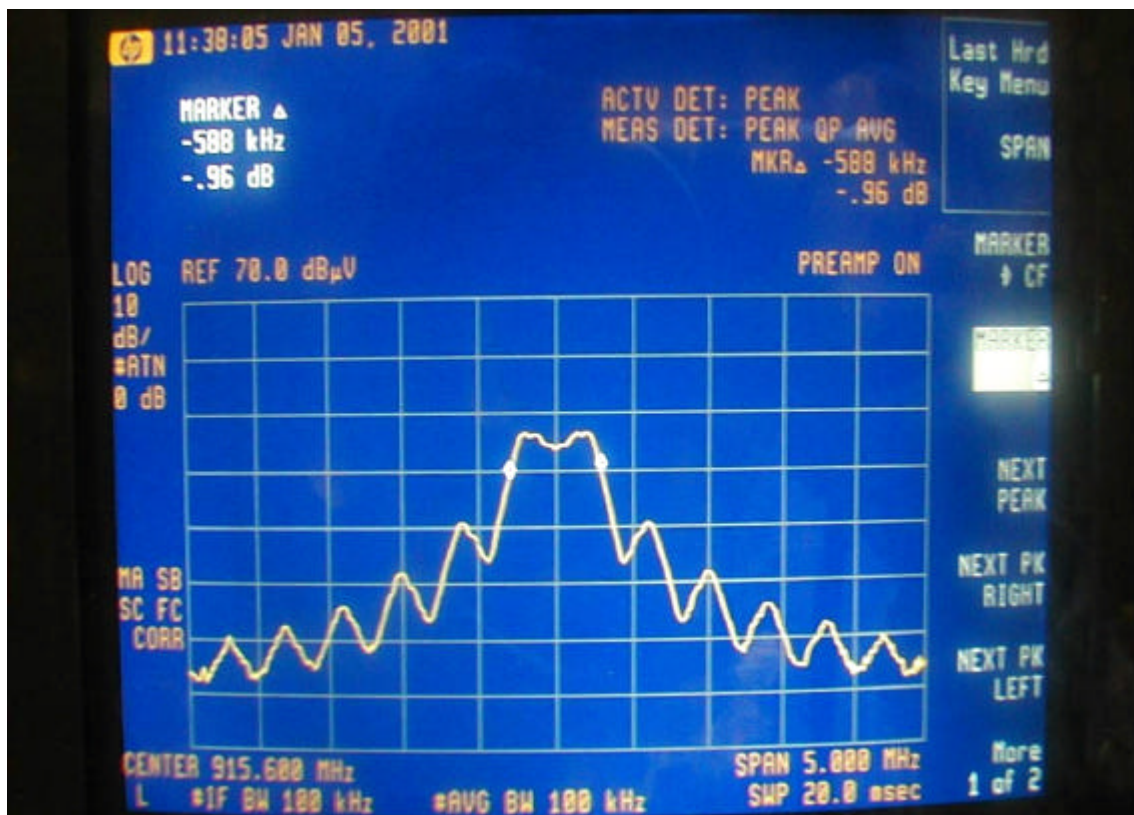
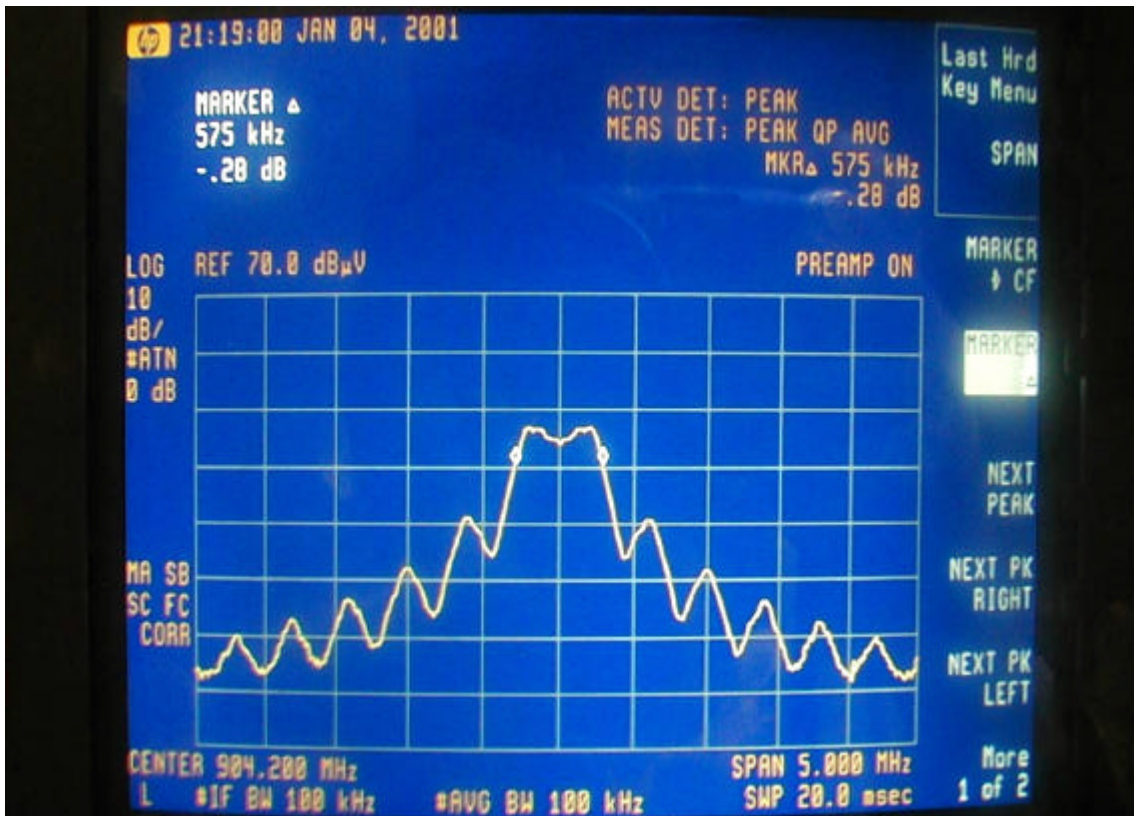

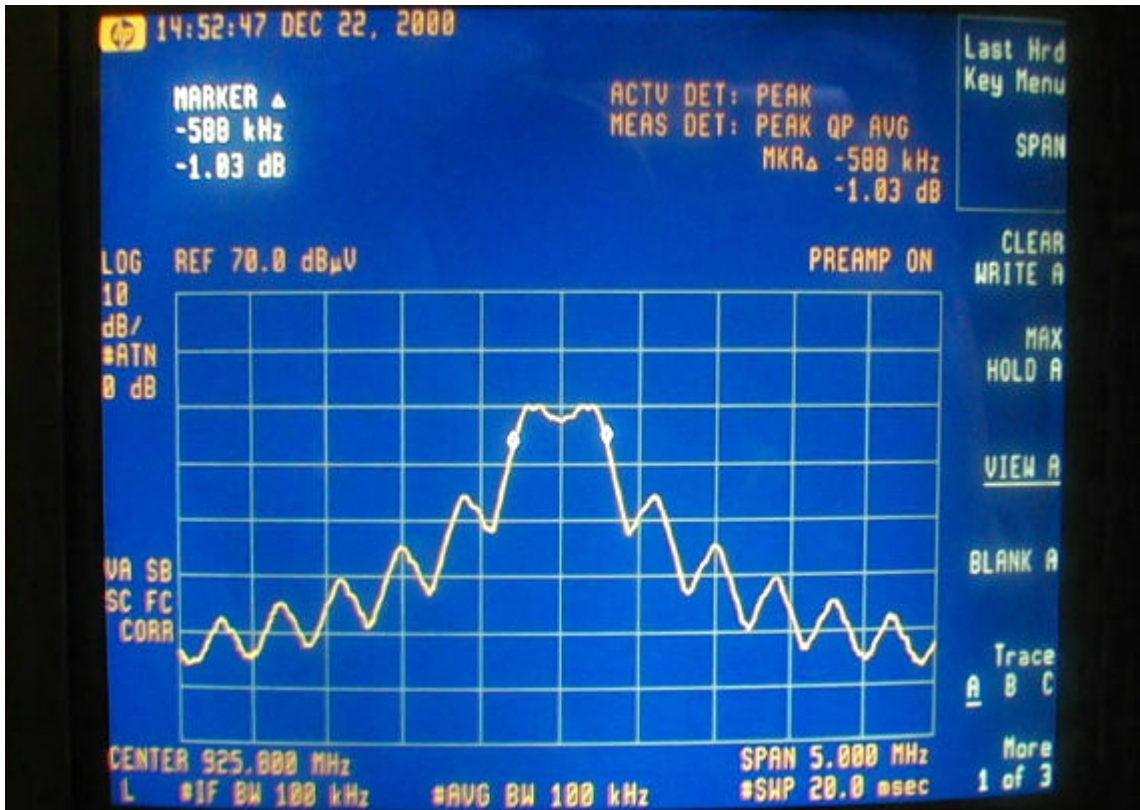



## **. Section 15.247(B): Power Output**

### **4.1 Test Condition & Setup**

The EUT was placed in an anechoic chamber and scanned at 3-meter distance to determine its emission characteristics. The physical arrangement of the EUT was varied (within the scope of arrangements likely to be encountered in actual use) to determine the effect on the unit's emanations in amplitude, directivity, and frequency. The exact system configuration that produced the highest emissions was noted so it could be reproduced later during the final tests. This was done to ensure that the final measurements would demonstrate the worst-case interference potential of the EUT. Final radiation measurements were made on a three-meter, anechoic chamber. The EUT system was placed on a nonconductive turntable, which is 0.8 meters height, top surface 1.0 x 1.5 meter.

The spectrum was examined from 30 MHz to 1000 MHz using an Hewlett Packard 85460A EMI Receiver, Schaffner whole range Bi-Log antenna (Model No.: CBL6141A) is used to measure frequency from 30 MHz to 1GHz. The final test is used the spectrum HP 85460A. At each frequency, the EUT was rotated 360 degrees, and the antenna was raised and lowered from one to four meters to find the maximum emission levels. Measurements were taken using both horizontal and vertical antenna polarization.

Appropriate preamplifiers were used for improving sensitivity and precautions were taken to avoid overloading or desensitizing the spectrum analyzer. The spectrum analyzer HP85460A used on this testing for frequency 30MHz to 1000MHz. No post-detector video filters were used in the test. Set the RB= 3 MHz, VB = 3MHz and the span = 5 MHz. The analyzer was operated in the maximum hold mode.

There are two test condition apply in this test item, the test procedure description as the following:  
Headset station transmit only:

Using the RS-232 port of PC and Rockwell software to control the headset. Then making access to the mode of continuous transmission. Three channels were tested, one in the top (CH01), one in the middle (CH11) and the other in bottom (CH20).

With the transmitter operating from a fully charged battery and using the internal antenna,

Radiates spurious emissions falling within the restricted bands of 15.209 were measured at operating frequencies corresponding to low, mid and high channels in the 902 ~ 928 MHz band.

The actual field intensity in decibels referenced to 1 micro-volt per meter (dB  $\mu$  V/m) is determined by algebraically adding the measured reading in dB  $\mu$  V, the antenna factor (dB), and cable loss (dB) at the appropriate frequency.

#### 4.2 List of Test Instruments

Instrument Name	Model No	Brand	Serial No.	Last time	Next time
EMI Receiver	8546A	H P	3520A00242	10/18/00	10/18/01
RF Filter Section	85460A	H P	3448A00217	10/18/00	10/18/01
Switch/Control Unit (> 30MHz)	3488A	H P	N/A	11/22/00	11/22/01
Auto Switch Box (> 30MHz)	ASB-01	TRC	9904-01	11/22/00	11/22/01
Bi-log Antenna	CBL6141A	Schaffner	4151	07/04/00	07/04/01

**4.3 Test Result of Fundamental Emissions**

The peak values of fundamental emissions from the EUT at various antenna heights, antenna polarization, EUT orientation, etc. are recorded on the following.

**FCC ID : FU5FE001**

**Table 2 Open Field Fundamental Emissions**

Channel	Frequency (MHz)	A.P. (H/V)	A.H. (M)	Table (degree)	Amplitude (dBmV/m)	CF (dB)	Duty Cycle (dB)	Corrected Amplitude (dBmV/m)	Corrected Amplitude (dBmV/m)	E.I.R.P.	
										Included Duty Cycle	
										m W	dB m
CH 01	904.20	H	1.00	56	55.95	-27.58	-6.46	77.07	83.53	0.067	-11.700
	904.20	V	1.00	90	54.65	-28.45	-6.46	76.64	83.10	0.061	-12.130
CH 11	915.60	H	1.00	88	49.42	-27.76	-6.46	70.72	77.18	0.015	-18.050
	915.60	V	1.00	15	54.38	-28.75	-6.46	76.67	83.13	0.061	-12.100
CH 20	925.80	H	1.00	19	57.75	-27.99	-6.46	79.28	85.74	0.112	-9.490
	925.80	V	1.00	80	55.69	-29.24	-6.46	78.47	84.93	0.093	-10.300

Note:

1. A. P. means antenna polarization, horizontal and vertical.
2. A. H. means antenna height.
3. Table means turn table turning position.
4. Corrected Factor (C. F.) = Cable Loss + Antenna Factor – Amplified Gain  
 Corrected Amplitude (Included Duty Cycle) = Peak Amplitude - Corrected Factor  
 Corrected Amplitude (Excluded Duty Cycle) = Peak Amplitude - Corrected Factor +Duty Cycle
5. Amplitude means the fundamental emission measured.
6. Conducted output power “P”,  $P = (E d)^2 / 30G$
7. Since  $G=1$ ;  $P=EIRP$

E is the measured maximum field strength in V/m utilizing the maximum hold mode RBW (3MHz)  
 G is the numeric gain of the transmitting antenna over an isotropic radiator (1.00)  
 d is the distance in meters from which the field strength was measured (3M)

Example: the Max Radiation Emission = 85.74 dBμV/m

$$10^{(85.74/20)} \times 10^{-6} = 0.019364 \text{ V}$$

$$\begin{aligned} \text{E.I.R.P.} &= (0.019364 \times 3)^2 / 30 = 0.1124919 \text{ mW} = 10 \times \log (0.1124919 \text{ mW} / 1 \text{ mW}) \\ &= -9.48878 \text{ dBm} \end{aligned}$$

## **. Section 15.247 (C)(2): Spurious Emissions (Radiated)**

### **5.1 Test Condition & Setup**

The EUT was placed in a anechoic chamber and scanned at 3 meter distance to determine its emission characteristics. The physical arrangement of the EUT was varied (within the scope of arrangements likely to be encountered in actual use) to determine the effect on the unit's emanations in amplitude, directivity, and frequency. The exact system configuration, which produced the highest emissions was noted so it could be reproduced later during the final tests. This was done to ensure that the final measurements would demonstrate the worst-case interference potential of the EUT.

Final radiation measurements were made on a three-meter, anechoic chamber. The EUT system was placed on a nonconductive turntable, which is 0.8 meters height, top surface 1.0 x 1.5 meter.

The spectrum was examined from 30 MHz to 1000 MHz using an Hewlett Packard 85460A EMI Receiver, Schaffner whole range Bi-Log antenna (Model No.: CBL6141A) is used to measure frequency from 30 MHz to 1GHz. The final test is used the spectrum HP 85460A and spectrum was examined from 1GHz to 18GHz using an Hewlett Packard 8564E Spectrum Analyzer, EMCO Horn Antenna (Model 3115) for 1G ~ 18GHz.

At each frequency, the EUT was rotated 360 degrees, and the antenna was raised and lowered from one to four meters to find the maximum emission levels. Measurements were taken using both horizontal and vertical antenna polarization.

Appropriate preamplifiers were used for improving sensitivity and precautions were taken to avoid overloading or desensitizing the spectrum analyzer. There are two spectrum analyzers use on this testing, HP 85460A for frequency 30MHz to 1000MHz, and 8564E for frequency 1GHz to 18GHz. No post-detector video filters were used in the test. The spectrum analyzer's 6 dB bandwidth was set to 120KHz (spectrum was examined from 30 MHz to 1000 MHz), the spectrum analyzer's 6 dB bandwidth was set to 1 MHz (spectrum was examined from 1GHz to 18GHz) and the analyzer was operated in the maximum hold mode.

There are two test condition apply in this test item, the test procedure description as the following:

Headset station transmit only:

Using the RS-232 port of PC and Rockwell software to control the headset. Then making access to the mode of continuous transmission. Three channels is tested, one in the top (CH01), one in the middle (CH11) and the other in bottom (CH20).

With the transmitter operating from a fully charged battery and using the internal antenna, radiates spurious emissions falling within the restricted bands of 15.209 were measured at operating frequencies corresponding to low, mid and high channels in the 902 ~ 928 MHz band.

The actual field intensity in decibels referenced to 1 micro-volt per meter (dB $\mu$ V/m) is determined by algebraically adding the measured reading in dB $\mu$ V, the antenna factor (dB), and cable loss (dB) at the appropriate frequency.

**For frequency between 30MHz to 1000MHz**

$F_{Ia} \text{ (dB}\mu\text{V/m)} = F_{Ir} \text{ (dB}\mu\text{V)} - \text{Correction Factors}$

$F_{Ia}$  : Actual Field Intensity

$F_{Ir}$  : Reading of the Field Intensity

Correction Factors = Antenna Factor + Cable Loss – Amplifier Gain

**For frequency between 1 GHz to 18 GHz**

$F_{Ia} \text{ (dB}\mu\text{V/m)} = F_{Ir} \text{ (dB}\mu\text{V)} + \text{Correction Factor} - \text{Duty Cycle}$

$F_{Ia}$  : Actual Field Intensity

$F_{Ir}$  : Reading of the Field Intensity

Correction Factors = Antenna Factor + Cable Loss – Distance Factor (9.54dB) – Amplifier Gain

The setting up procedure is recorded on Appendix A.

**5.2 List of Test Instruments**

Instrument Name	Model No	Brand	Serial No.	Last time	Next time
EMI Receiver	8546A	H P	3520A00242	10/18/00	10/18/01
RF Filter Section	85460A	H P	3448A00217	10/18/00	10/18/01
Switch/Control Unit	3488A	H P	N/A	11/22/00	11/22/01
(> 30MHz)					
Auto Switch Box	ASB-01	TRC	9904-01	11/22/00	11/22/01
(> 30MHz)					
Bi-log Antenna	CBL6141A	Schaffner	4151	07/04/00	07/04/01
Spectrum Analyzer	8564E	H P	US36433002	08/13/00	08/13/01
Microwave Preamplifier	83051A	H P	3232A00347	08/13/00	08/13/01
Horn Antenna	3115	EMCO	9704 – 5178	08/15/00	08/15/01

**5.2.1 Duty Cycle Factor Measurement**

The duty cycle factor measurement is performed in a shield enclosure. The test condition and setup is as same as paragraph . Set the RB = 1MHz, VB=1MHz, and span = 0 MHz. Link the base and handset, then get the Time of duty and cycle as follow page.

The duty cycle factor =  $20 \log ( T_{duty} / T_{cycle} ) = 20 \log ( 0.950/2.000 ) = - 6.46$

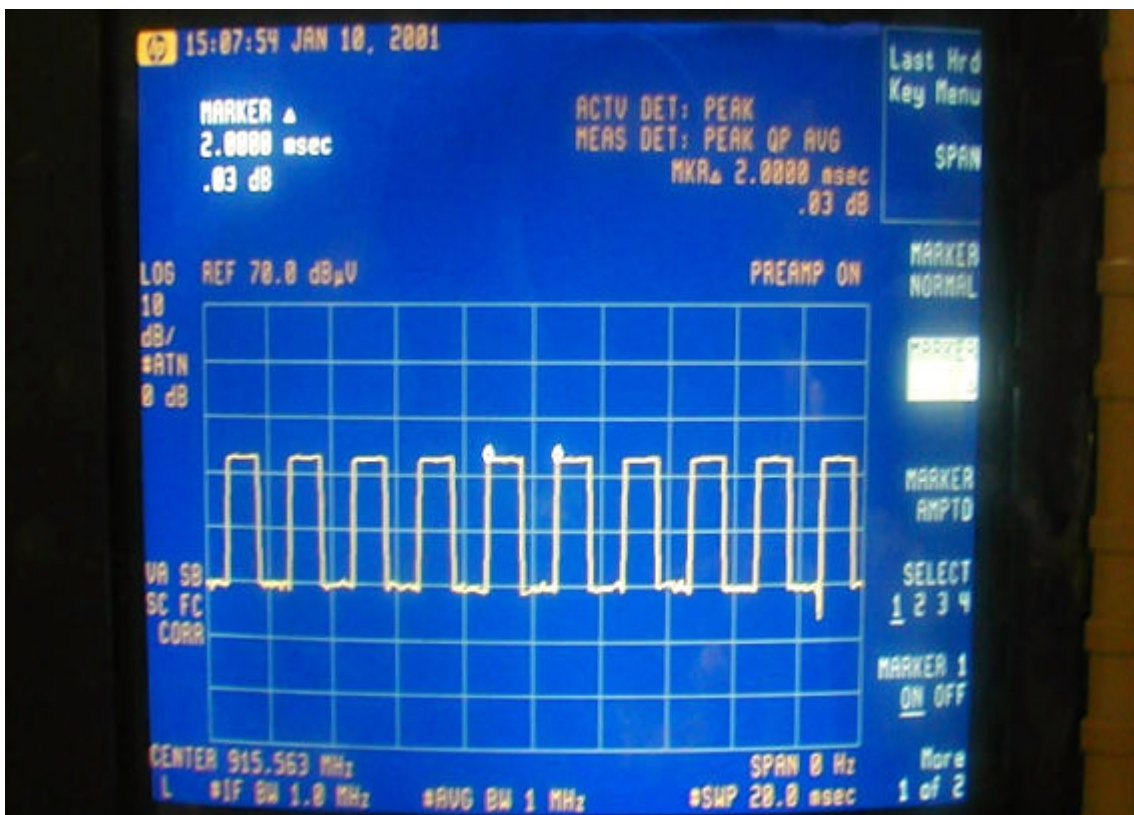
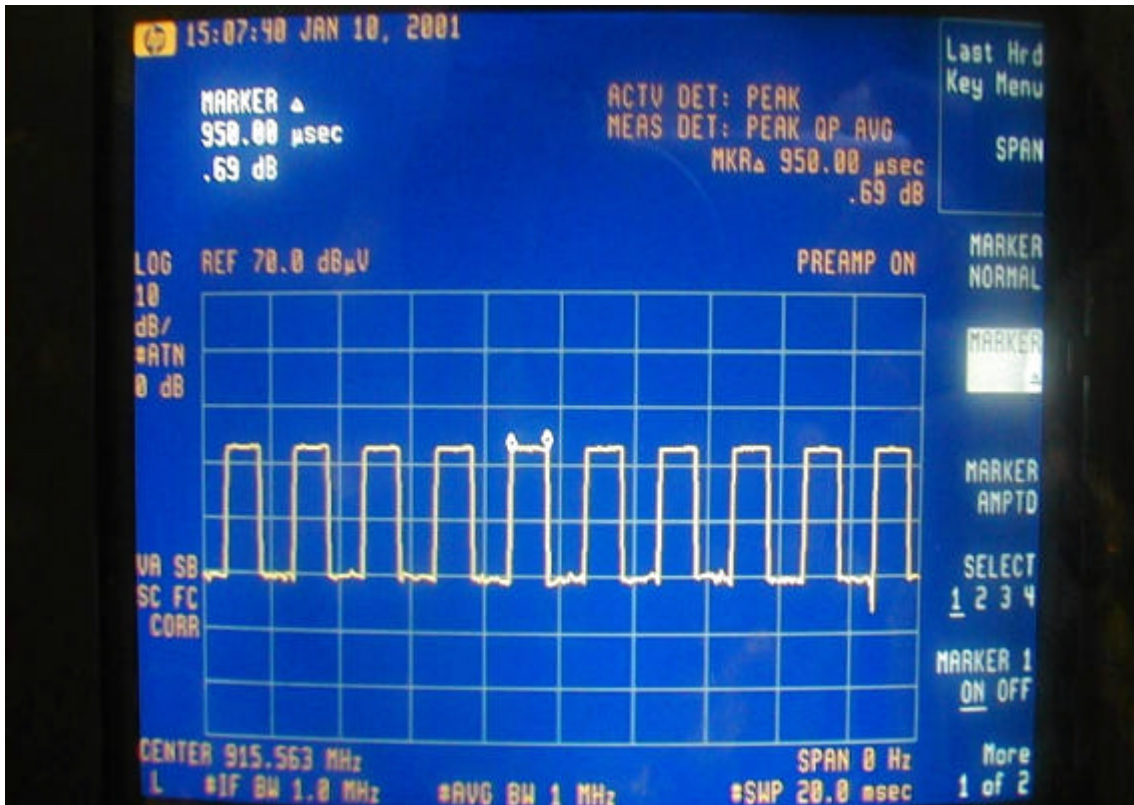

### 5.3 Test Instruments Configuration



Fig 1 Front View of the Test Configuration



Fig 2 Rear View of the Test Configuration

**The test configuration for frequency between 1 GHz to 18 GHz is same as above.**

**5.4 Test Result of Second Harmonic**

Set the spectrum RB= 3 MHz, VB = 3MHz and span = 5MHz. The correction factors of the second harmonic are the second harmonic must lower 20 dB than the fundamental.

**EUT** : D.S.S. Wireless Handfree Kit for Headset  
**FCC ID** : FU5FE001

**Table 3 Second Harmonic Attenuation**

<b>Channel</b>	<b>Fundamental (MHz)</b>	<b>Fundamental (dBmV/m)</b>	<b>2<sup>nd</sup> Harmonic (GHz)</b>	<b>2<sup>nd</sup> Harmonic (dBmV/m)</b>	<b>Result (F/H dB)</b>	<b>Limit (dB)</b>	<b>Margin (dB)</b>
CH 01	904.20	83.53	1.808	45.97	37.56	20.00	17.56
CH 11	915.60	83.13	1.823	44.83	38.30	20.00	18.30
CH 20	925.80	85.74	1.845	43.97	41.77	20.00	21.77

Note:

1. The 2<sup>nd</sup> Harmonic is comply with 15.209.
2. Result = Fundamental (Peak)– 2<sup>nd</sup> Harmonic(Peak) must over 20 dB and comply with 15.209.



**5.5 Test Result of Spurious Radiated Emissions**

**5.5.1 Headset station transmit only**

The highest peak values of radiated emissions from the EUT at various antenna heights, antenna polarization, EUT orientation, etc. are recorded on the following.

Test Conditions:      Testing room : Temperature      : 26 ° C      Humidity    : 73 % RH  
                                          Testing site    : Temperature      : 31 ° C      Humidity    : 75 % RH

**Table 4 Open Field Radiated Emissions For 30MHz    1GHz [Channel 1, Horizontal]**

<b>Radiated Emission</b>				<b>Correction Factors</b>	<b>Corrected Amplitude</b>	<b>FCC Class B ( 3 m )</b>	
<b>Frequency (MHz)</b>	<b>Amplitude (dBmV/m)</b>	<b>Ant. H. (m)</b>	<b>Table ( ° )</b>			<b>Limit (dBmV/m)</b>	<b>Margin (dB)</b>
192.001	25.78	1.00	12	-12.87	38.65	43.50	-4.85
288.002	22.63	1.00	151	-15.78	38.41	46.00	-7.59
297.601	22.03	1.00	105	-16.27	38.30	46.00	-7.70
451.201	11.42	2.43	140	-20.58	32.00	46.00	-14.00
739.200	4.86	1.00	67	-26.28	31.14	46.00	-14.86
***							

Note:

1. Margin = Corrected – Limit.
2. Peak Amplitude – Correction Factors = Corrected

**Table 5 Open Field Radiated Emissions For 1GHz ~ 18GHz [Channel 1, Horizontal]**

<b>Radiated Emission</b>				<b>Correction Factors ( dB )</b>	<b>Duty Cycle ( dB )</b>	<b>Corrected Amplitude (dBm V/m)</b>	<b>FCC Class B ( 3 m )</b>	
<b>Frequency (GHz)</b>	<b>Amplitude (dBm V/m)</b>	<b>Ant. H. (m)</b>	<b>Table ( ° )</b>				<b>Limit (dBm V/m)</b>	<b>Margin (dB)</b>
1.808	44.49	1.00	177	-8.67	-6.46	29.36	54.00	-24.64
***								

Note:

1. Margin = Corrected – Limit.
2. Peak Amplitude + Correction Factor + Duty Cycle = Corrected

Table 6 Open Field Radiated Emissions For 30MHz 1GHz [Channel 1, Vertical]

Radiated Emission				Correction Factors (dB)	Corrected Amplitude (dBmV/m)	FCC Class B (3 m)	
Frequency (MHz)	Amplitude (dBmV/m)	Ant. H. (m)	Table ( ° )			Limit (dBmV/m)	Margin (dB)
***							

\*The emissions of this polarity are all under the limits more than 20dB.

**Table 7 Open Field Radiated Emissions For 1GHz 18GHz [Channel 1, Vertical]**

<b>Radiated Emission</b>				<b>Correction Factors</b> ( dB )	<b>Duty Cycle</b> ( dB )	<b>Corrected Amplitude</b> (dBm V/m)	<b>FCC Class B ( 3 m )</b>	
<b>Frequency (GHz)</b>	<b>Amplitude (dBm V/m)</b>	<b>Ant. H. (m)</b>	<b>Table ( ° )</b>				<b>Limit (dBm V/m)</b>	<b>Margin (dB)</b>
1.808	54.64	1.00	219	-8.67	-6.46	39.51	54.00	-14.49
***								

**Table 8 Open Field Radiated Emissions For 30MHz 1GHz [Channel 11, Horizontal]**

<b>Radiated Emission</b>				<b>Correction Factors</b>	<b>Corrected Amplitude</b>	<b>FCC Class B (3 m)</b>	
<b>Frequency (MHz)</b>	<b>Amplitude (dBmV/m)</b>	<b>Ant. H. (m)</b>	<b>Table ( ° )</b>			<b>Limit (dBmV/m)</b>	<b>Margin (dB)</b>
192.001	19.81	1.00	50	-12.87	32.68	43.50	-10.82
211.202	17.05	1.00	2	-14.19	31.24	43.50	-12.26
268.801	22.12	1.00	122	-15.55	37.67	46.00	-8.33
288.002	23.68	1.00	94	-15.78	39.46	46.00	-6.54
451.201	15.12	1.00	124	-20.58	35.70	46.00	-10.30
***							

**Table 9 Open Field Radiated Emissions For 1GHz 18GHz [Channel 11, Horizontal]**

<b>Radiated Emission</b>				<b>Correction Factors ( dB )</b>	<b>Duty Cycle ( dB )</b>	<b>Corrected Amplitude (dBm V/m)</b>	<b>FCC Class B ( 3 m )</b>	
<b>Frequency (GHz)</b>	<b>Amplitude (dBm V/m)</b>	<b>Ant. H. (m)</b>	<b>Table ( ° )</b>				<b>Limit (dBm V/m)</b>	<b>Margin (dB)</b>
1.823	46.14	1.00	159	-8.67	-6.46	31.01	54.00	-22.99
2.738	50.64	1.00	202	-6.84	-6.46	37.34	54.00	-16.66
***								

**Table 10 Open Field Radiated Emissions For 30MHz 1GHz [Channel 11, Vertical]**

<b>Radiated Emission</b>				<b>Correction Factors</b>	<b>Corrected Amplitude</b>	<b>FCC Class B (3 m)</b>	
<b>Frequency (MHz)</b>	<b>Amplitude (dBmV/m)</b>	<b>Ant. H. (m)</b>	<b>Table ( ° )</b>			<b>Limit (dBmV/m)</b>	<b>Margin (dB)</b>
***							

**\*The emissions of this polarity are all under the limits more than 20dB.**

**Table 11 Open Field Radiated Emissions For 1GHz 18GHz [Channel 11, Vertical]**

<b>Radiated Emission</b>				<b>Correction Factors</b> ( dB )	<b>Duty Cycle</b> ( dB )	<b>Corrected Amplitude</b> (dBm V/m)	<b>FCC Class B ( 3 m )</b>	
<b>Frequency (GHz)</b>	<b>Amplitude (dBm V/m)</b>	<b>Ant. H. (m)</b>	<b>Table ( ° )</b>				<b>Limit (dBm V/m)</b>	<b>Margin (dB)</b>
1.823	53.50	1.00	53	-8.67	-6.46	38.37	54.00	-15.63
2.738	51.31	1.00	117	-6.84	-6.46	38.01	54.00	-15.99
***								



*Table 12 Open Field Radiated Emissions For 30MHz 1GHz [Channel 20, Horizontal]*

<i>Radiated Emission</i>				<i>Correction Factors</i>	<i>Corrected Amplitude</i>	<i>FCC Class B (3 m)</i>	
<i>Frequency (MHz)</i>	<i>Amplitude (dBmV/m)</i>	<i>Ant. H. (m)</i>	<i>Table ( ° )</i>			<i>Limit (dBmV/m)</i>	<i>Margin (dB)</i>
192.001	24.63	1.00	8	-12.87	37.50	43.50	-6.00
268.801	23.21	1.00	106	-15.55	38.76	46.00	-7.24
288.002	24.88	1.00	140	-15.78	40.66	46.00	-5.34
412.801	15.89	1.00	70	-20.05	35.94	46.00	-10.06
***							

**Table 13 Open Field Radiated Emissions For 1GHz ~ 18GHz [Channel 20, Horizontal]**

<b>Radiated Emission</b>				<b>Correction Factors ( dB )</b>	<b>Duty Cycle ( dB )</b>	<b>Corrected Amplitude (dBm V/m)</b>	<b>FCC Class B ( 3 m )</b>	
<b>Frequency (GHz)</b>	<b>Amplitude (dBm V/m)</b>	<b>Ant. H. (m)</b>	<b>Table ( ° )</b>				<b>Limit (dBm V/m)</b>	<b>Margin (dB)</b>
1.845	46.64	1.00	137	-8.67	-6.46	31.51	54.00	-22.49
2.768	46.14	1.00	294	-6.84	-6.46	32.84	54.00	-21.16
***								

**Table 14 Open Field Radiated Emissions For 30MHz 1GHz [Channel 20, Vertical]**

<b>Radiated Emission</b>				<b>Correction Factors</b>	<b>Corrected Amplitude</b>	<b>FCC Class B (3 m)</b>	
<b>Frequency (MHz)</b>	<b>Amplitude (dBmV/m)</b>	<b>Ant. H. (m)</b>	<b>Table ( ° )</b>			<b>Limit (dBmV/m)</b>	<b>Margin (dB)</b>
***							

**\*The emissions of this polarity are all under the limits more than 20dB.**

**Table 15 Open Field Radiated Emissions For 1GHz 18GHz [Channel 20, Vertical]**

<b>Radiated Emission</b>				<b>Correction Factors</b> ( dB )	<b>Duty Cycle</b> ( dB )	<b>Corrected Amplitude</b> (dBm V/m)	<b>FCC Class B ( 3 m )</b>	
<b>Frequency (GHz)</b>	<b>Amplitude (dBm V/m)</b>	<b>Ant. H. (m)</b>	<b>Table ( ° )</b>				<b>Limit (dBm V/m)</b>	<b>Margin (dB)</b>
1.845	52.64	1.00	97	-8.67	-6.46	37.51	54.00	-16.49
2.768	47.81	1.00	271	-6.84	-6.46	34.51	54.00	-19.49
***								

## **. Section 15.247(d): Power Spectral Density**

### **6.1 Test Condition & Setup**

The tests below are running with the EUT transmitter set at high power in TDD mode. A serial port from a computer to the EUT. EUT is needed to force selection of output power level and channel number. While testing, EUT was set to transmit continuously. A log antenna was connected with the spectrum analyzer.

The EUT is tested in open field site. Put EUT on the middle of a wooden table. Set spectrum analyzer RBW = 3 KHz, VBW > RBW (e.g. VBW = 10 KHz), Span = 1.5 MHz. Turn around the table to find maximum emission. Then set the Span = 300 KHz and sweep time = 100 sec. Peak the maximum emission again. The peak level measured must be no greater than + 8dBm.

The setting up procedure is recorded on Appendix A.

**6.2 Test Instruments Configuration**

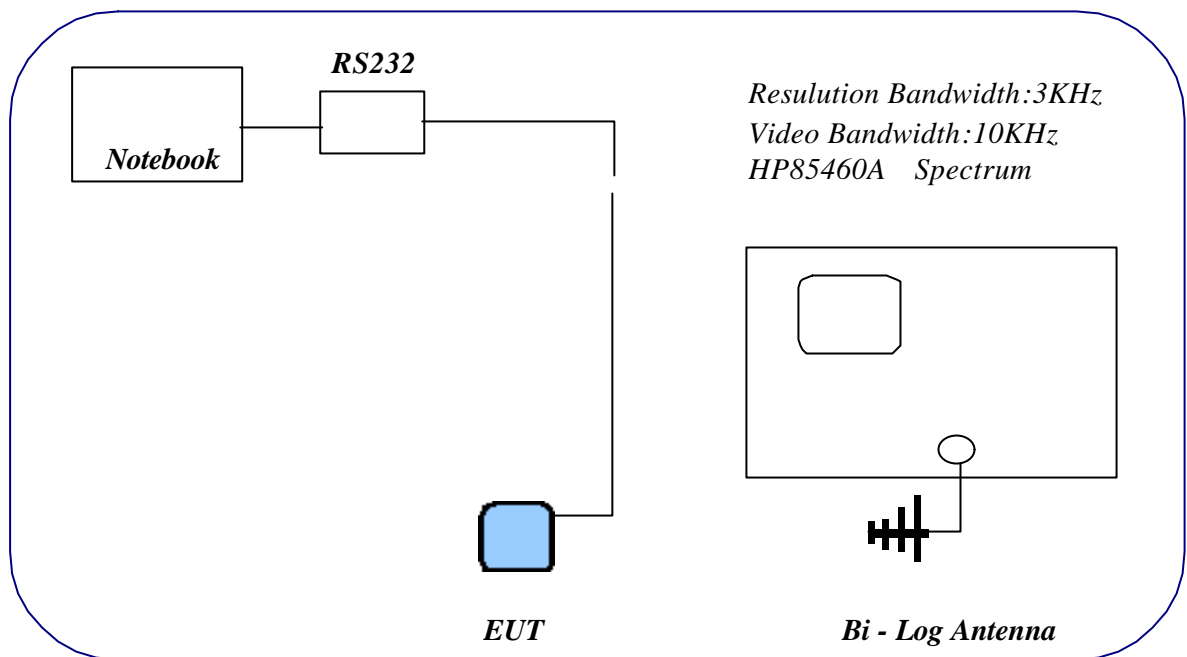

*P.S. A serial port from notebook computer to control the EUT at maximal power output and channel Number.*

Fig 12. Test Configuration of power spectral density

**6.3 List of Test Instruments**

Instrument Name	Model No	Brand	Serial No.	Last time	Next time
EMI Receiver	8546A	H P	3520A00242	10/18/00	10/18/01
RF Filter Section	85460A	H P	3448A00217	10/18/00	10/18/01
Switch/Control Unit (> 30MHz)	3488A	H P	N/A	11/22/00	11/22/01
Auto Switch Box (> 30MHz)	ASB-01	TRC	9904-01	11/22/00	11/22/01
Bi-log Antenna	CBL6141A	Schaffner	4151	07/04/00	07/04/01

#### **6.4 Required of Carrier frequency**

If any 100 kHz bandwidth outside these frequency bands, the radio frequency power that is produced by the modulation products of the spreading sequence, the information sequence and the carrier frequency shall be either at least 20 dB below that in any 100 kHz bandwidth within the band that contains the highest level of the desired power or shall not exceed the general levels specified in § 15.209(a), whichever results in the lesser attenuation.

Test Condition & Setup: same as 3.1

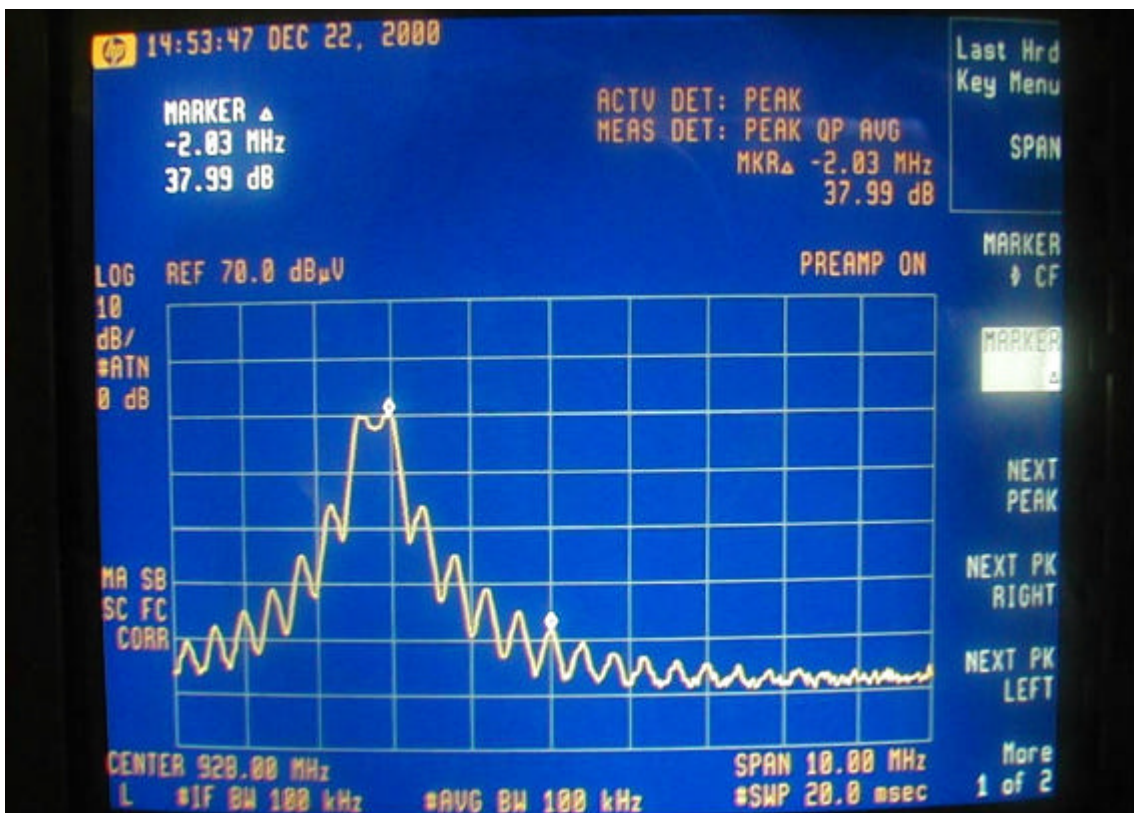
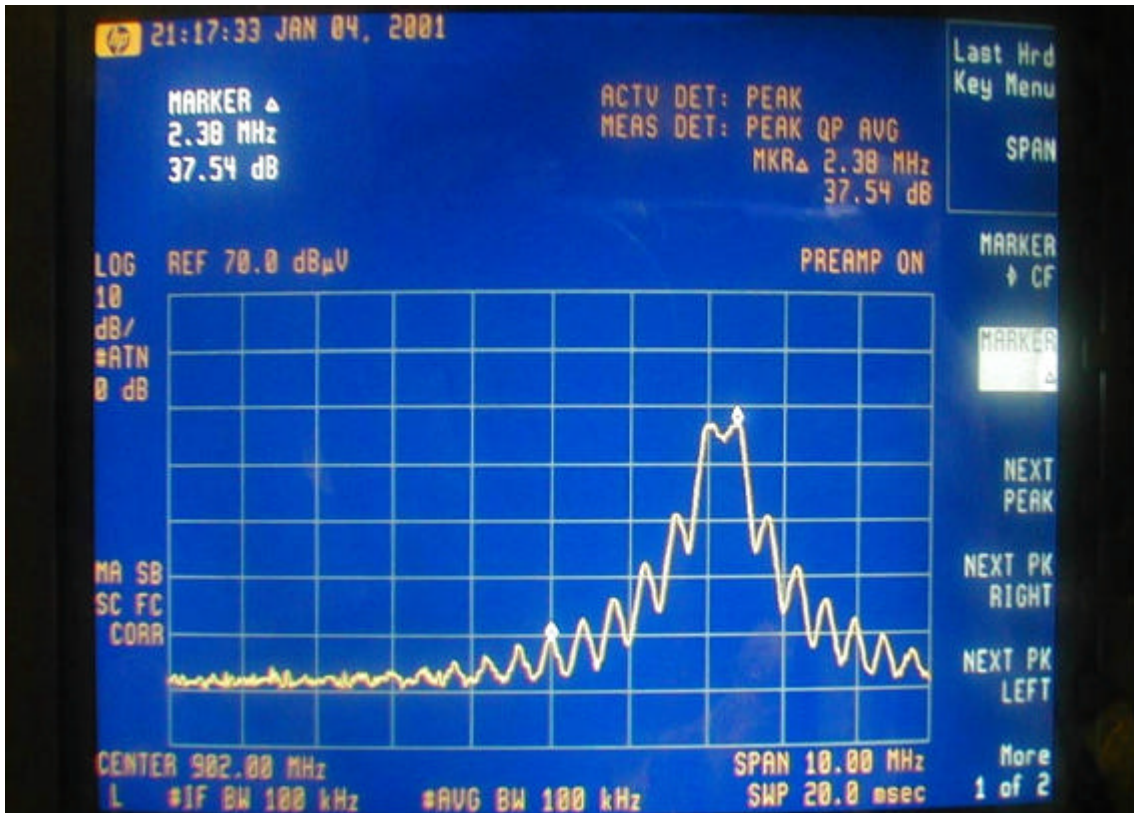



**6.5 Test Result of Power spectral density**

The following table shows a summary of the highest power out of EUT.

**FCC ID** : FU5FE001  
**EUT** : D. S. S. Wireless Handfree Kit for Headset

*Table 16 Power Spectral Density*

<i>Channel</i>	<i>Frequency (MHz)</i>	<i>Ppr (dBuV)</i>	<i>CF (dB)</i>	<i>Ppq (dBm)</i>	<i>Limit (dB)</i>	<i>Margin (dB)</i>
CH 01	904.6543	43.01	-27.58	-24.64	8.00	-32.64
CH 11	916.0555	42.27	-27.76	-25.20	8.00	-33.20
CH 20	926.2553	44.62	-27.99	-22.62	8.00	-30.62

Note:

1. The attachment follow by this page and there is no page number.
2. Ppr: spectrum read power density (using peak search mode), CF: correct factor, Ppq: actual peak power density in the spread spectrum band.
3.  $Ppq = Ppr - CF$
4. Effective Radiation Power (E.R.P.) =  $(E d)^2 / 30G$

"E" is the measured maximum field strength in V/m utilizing the maximum hold mode RBW (3KHz).

"G" is the numeric gain of the transmitting antenna over an isotropic radiator (1.00).

"d" is the distance in meters from which the field strength was measured (3M).

Example: the Max Radiation Emission =  $44.62 - (-27.99) = 72.61 \text{ dB}\mu\text{V/m}$

$$10^{(72.61/20)} \times 10^{-6} = 0.004271 \text{ V}$$

$$\text{E.R.P.} = (0.004271 \times 3)^2 / 30 = 0.005472 \text{ mW} = 10 \times \log (0.005472 \text{ mW/1mW})$$

$$= -22.62 \text{ dBm}$$

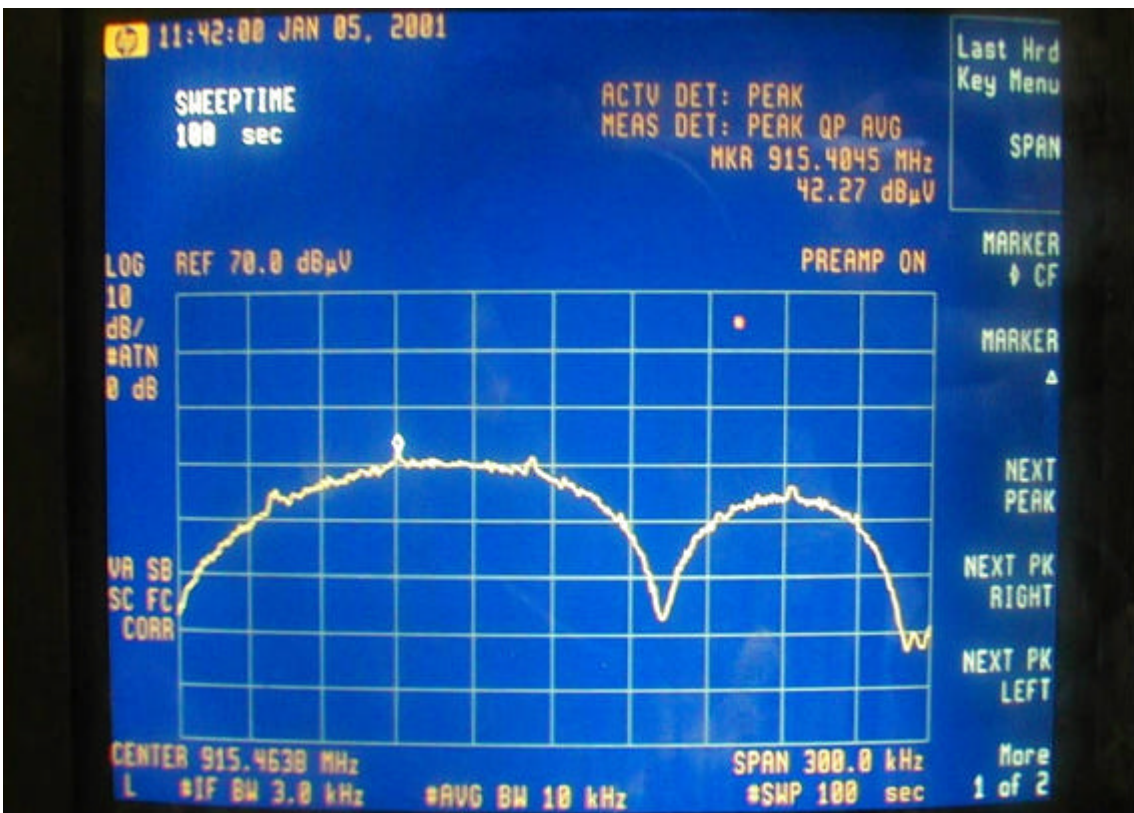
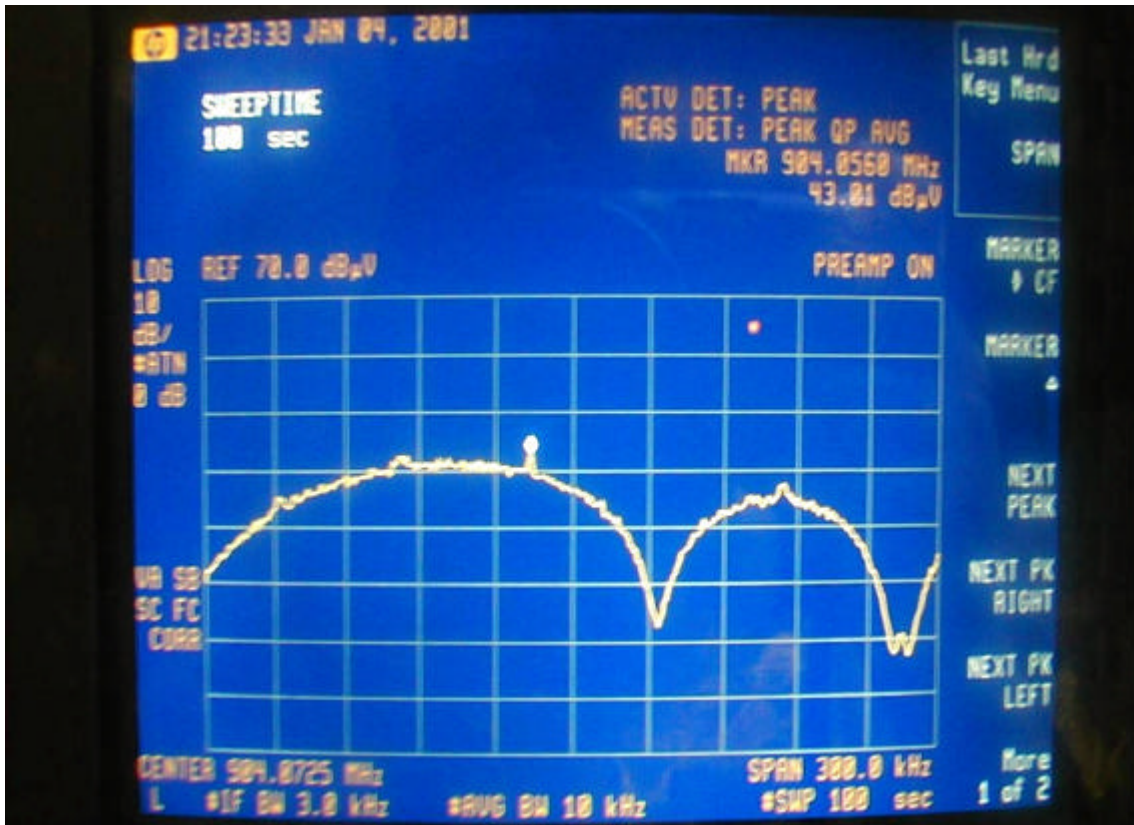

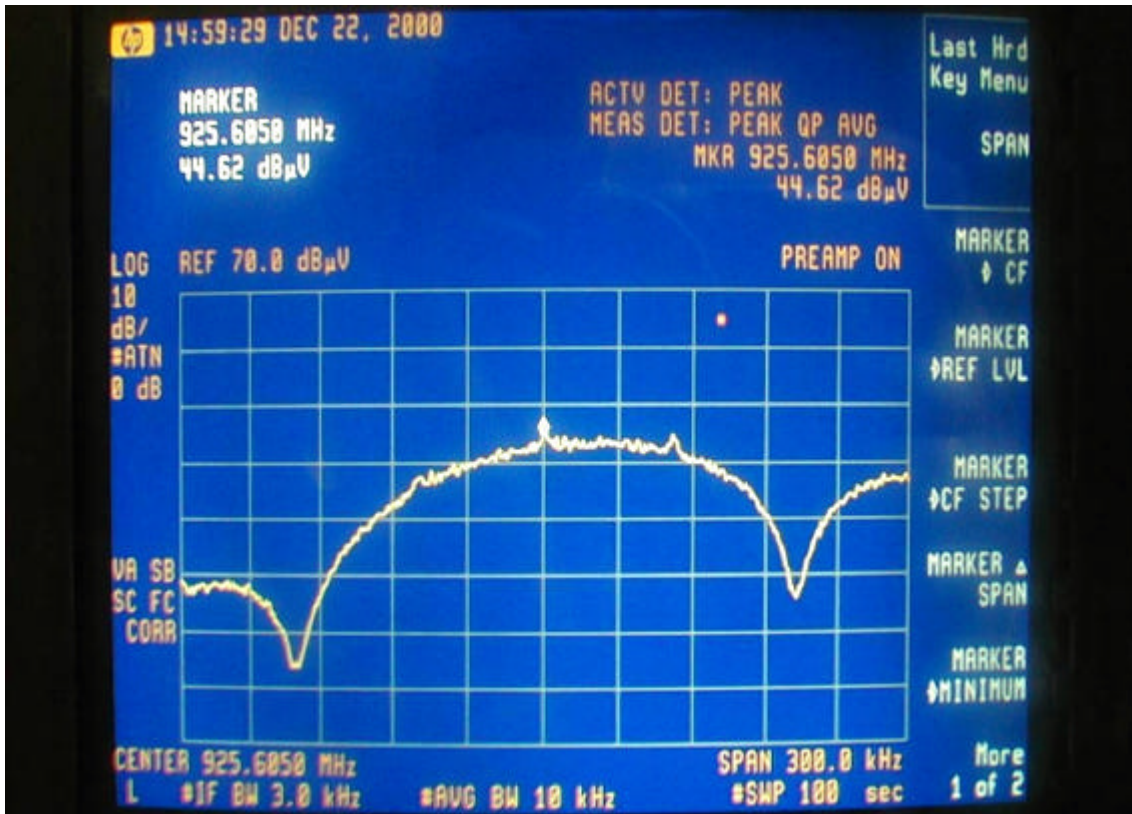

**. Section 15.247(e): Processing Gain**

**7.1 Test Condition & Setup**

**A. Bit Error Rate (Pe)**

The subjective device RF module (Headset and interface module) digital modulation by Differential Phase -Shift Keying (DPSK), the DPSK can use it's previous waveform as the phase reference for demodulation and thus requires no coherent detection, which greatly simplifies the receiver structure but with some Bit Error Rate (BER) degradation because of noisy phase reference. There is tradeoff between system complexity and system performance. In order to driver the DPSK error probability, we observe that DPSK using differential coding, we observable that DPSK using different coding is essentially an orthogonal signal scheme. A binary 1 is transmitted a sequence of two pulse (P,P) or (-P,-P) over 2 To seconds (no transition). Similarly, a binary 0 is transmitted by a sequence of two plus (P,-P) or (-P,P) over 2 TO seconds (transition). Either of the pulse sequences used for binary 1 is orthogonal to either of the pulse sequences used for binary 0. Because no local carrier is generated for demodulation, the detection is noncoherent, with an effective pulse energy equal to 2 Ep (twice the energy of pulse P). The actual energy transmitted per digit only Ep, however, the same as in noncoherent FSK, Consequently, the performance of DPSK is 3 dB superior to that of noncoherent FSK, We can write Pe for DPSK as :

The major component inside the subjective device are supplied by Rock well, Included RF block transmitter (RF101), Receiver (RF 100), and Base band block ASIC (c8502-13), CODEC (10497-14), above 4 IC chips are affected the processing gain as following :

$$J/S = (W/RD) / (ED/NO) \text{ [without CODING]}$$

Where: W= Spread Chip Rate = Required Transmitted Base band Bandwidth.

Rb = Information Data Rate

Eb/No = Require Energy per Bit over noise Spectral Density for a Specific Bit Error Probability.

The subjective Device Information Data Rate are 80k and the Spread Chip Rate are 960k So the processing gain (10 log w/Rb) at least 10.79 dB (without Coding).

The ASIC (c8502-13) and CODEC (10497-14) these two chip included the coding function, So, it is great improve the processing gain and also improve the J/S ratio.

The Engineer work for Rock well System in Taiwan had pass us the information about the probability of error rate (Pe) must be lower than 0.001 that the system performance will satisfy for communication between Handset and Base station.

Why we need the Pe lower than 0.001, the Rockwell Semiconductor System is not explained, Since it relative with ASIC and Codec, it is confidential area that Rockwell is not allow to disdouse to the public. When Pe = 0.001 and then Signal to Noise Ratio (S/N) = 6.2194 = 7.9dB.

## **B. Jamming Margin Method**

The Rockwell Semiconductor System give us a software operated in the personal computer, and use the computer series port COM1 and COM2 connect Headset and interface module than we can measure the Bit Error Rate.

Using this software we can perform Jamming Margin method testing, The test consists of stepping a signal generator in 50 KHz increments across the pass band of the system (up to 960 KHz away in RI's DCT). At each point, the generator level required to produce the recommend Bit Error Rate (BER =  $10e - 3$ ) is recorded. This level is the jamming level. The maximum implementation loss a system can claim in calculating processing gain is 2 dB. The equation to calculate the processing gain (Gp) is the following:

$$Gp = (S/N) + Mj + Lsys$$

$$Gp = 8 \text{ dB} + Mj + 2 \text{ dB}$$

FCC regulation section 15.247 (e) require the processing gain of a direct sequence system shall be at least 10 dB, when Gp must be greater than 10 dB, then the Jammer must be greater than 0 dB.

The processing gain may be measured using the CW jamming margin method. The Jammer to Signal (J/S) ratio is then calculated. Discard the worst 20% of the J/S data points.

1. For avoid the headset and interface module station are situation, so, the EUT were in low power mode.

2. The signal generator was selected in interference band, using this software we can perform Jamming Margin method testing, the test consists of stepping a signal generator is 50 KHz increments across the pass band of the system (up to 960 KHz away in RI's EUT). So, the BER will keep in 0.1%.

The setting up procedure is recorded on Appendix A.

7.2 Test Instruments Configuration

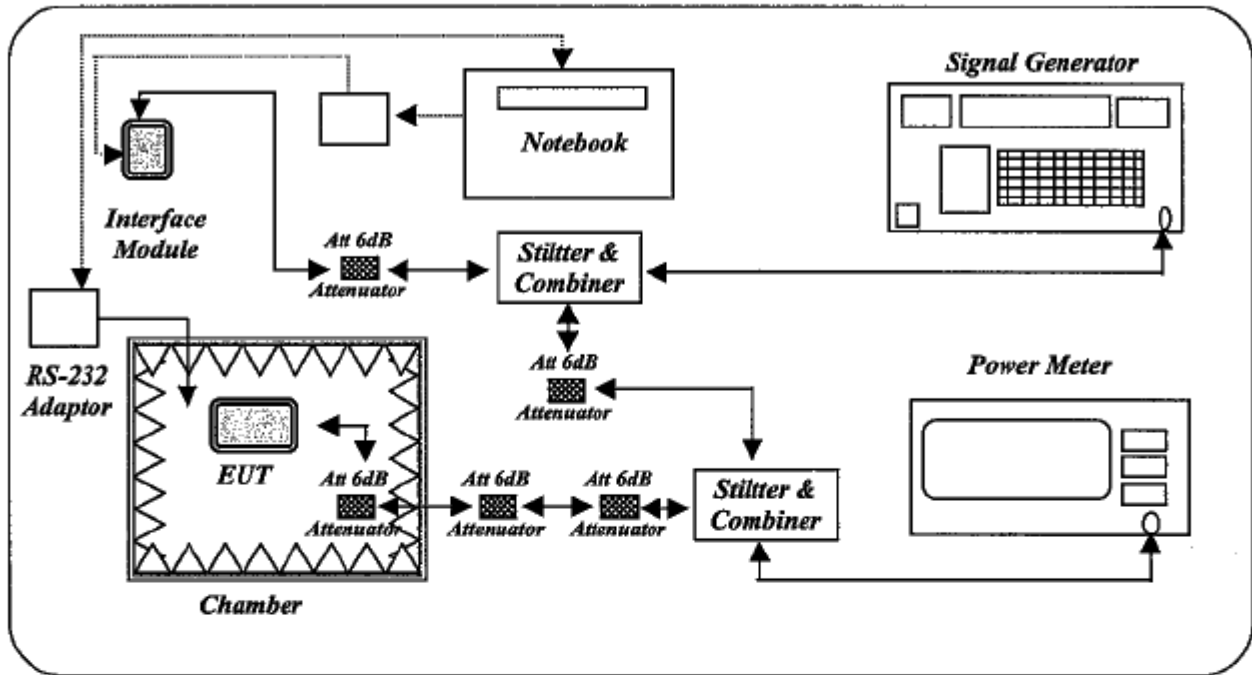

P.S A serial port from notebook computer to control the EUT at power output and channel number.  
 Test Configuration of processing gain for headset

**7.3 List of Test Instruments**

Instrument Name	Model No	Brand	Serial No.	Last time	Next time
Signal Generator	8648D	HP	3613A00117	05/19/00	05/19/01
Power Meter	E4418B	HP	GB39291240	09/11/00	09/11/01
Attenuator (6dB to 18 GHz)	MCL BW-S6W2	Mini Circuits			

**7.4 Test Procedure**

According to the Fig. 13, combine the stuffs.

Measure the high power output of the channel 11 of the headset while the headset is in "Transmit-Only-Test" and the whole circuit is as same as Fig. 13. What we measure in this step is "S".

Change to the "BER Test " program. Increase the RF output of the signal generator till the BER is close to the 0.1% but under 0.1%.

Stop the program and turn off the interface module, headset then record the highest point of the spectrum. What we measure in this step is "J".

Star the Program again and test the next point.

**7.5 Test Result of Processing Gain**

**Table 17 Processing Gain [Channel 11, 914.600 to 915.950 MHz]**

Jammer Frequency (MHz)	S (dBm)	J (dBm)	Mj (J/S)	Process Gain (dB)
914.600	-52.80	-45.88	6.92	16.82
914.650	-52.80	-49.85	2.95	12.85
914.700	-52.80	-50.15	2.65	12.55
914.750	-52.80	-49.74	3.06	12.96
914.800	-52.80	-49.48	3.32	13.22
914.850	-52.80	-51.30	1.50	11.40
914.900	-52.80	-51.18	1.62	11.52
914.950	-52.80	-44.00	8.80	18.70
915.000	-52.80	-50.63	2.17	12.07
915.050	-52.80	-45.60	7.20	17.10
915.100	-52.80	-49.72	3.08	12.98
915.150	-52.80	-49.70	3.10	13.00
915.200	-52.80	-46.07	6.73	16.63
915.250	-52.80	-45.05	7.75	17.65
915.300	-52.80	-45.06	7.74	17.64
915.350	-52.80	-43.00	9.80	19.70
915.400	-52.80	-41.00	11.80	21.70
915.450	-52.80	-49.85	2.95	12.85
915.500	-52.80	-49.85	2.95	12.85
915.550	-52.80	-47.52	5.28	15.18
915.600	-52.80	-42.55	10.25	20.15
915.650	-52.80	-45.21	7.59	17.49
915.700	-52.80	-45.20	7.60	17.50
915.750	-52.80	-46.20	6.60	16.50
915.800	-52.80	-42.85	9.95	19.85
915.850	-52.80	-44.28	8.52	18.42
915.900	-52.80	-44.19	8.61	18.51
915.950	-52.80	-41.88	10.92	20.82

- Note: 1.  $GP = (S/No) + Mj + Lsys$   
 $= 7.9dB + Mj + 2dB$
2. S = Signal Level
3. J = Signal Generator RF Output



**Table 18 Processing Gain [Channel 11, 916.000 to 916.600 MHz]**

Jammer Frequency (MHz)	S (dBm)	J (dBm)	Mj (J/S)	Process Gain (dB)
916.000	-52.80	-41.88	10.92	20.82
916.050	-52.80	-41.75	11.05	20.95
916.100	-52.80	-41.88	10.92	20.82
916.150	-52.80	-34.84	17.96	27.86
916.200	-52.80	-39.85	12.95	22.85
916.250	-52.80	-34.85	17.95	27.85
916.300	-52.80	-36.26	16.54	26.44
916.350	-52.80	-37.47	15.33	25.23
916.400	-52.80	-32.64	20.16	30.06
916.450	-52.80	-32.74	20.06	29.96
916.500	-52.80	-30.35	22.45	32.35
916.550	-52.80	-30.40	22.40	32.30
916.600	-52.80	-30.00	22.80	32.70

**Test Result : Processing Gain: 12.98 dB**

- Note: 1.  $GP = (S/No) + Mj + Lsys$   
 $= 7.9dB + Mj + 2 dB$
2. S = Signal Level
3. J = Signal Generator RF Output

## *Appendix A*

### **Setting up Procedure**

1. Using an RS-232 Adaptor that is given by customer connected with the COM 1 of the computer.
2. The other end of the RS-232 Adaptor is connected with the EUT.
3. Use the software that is given by the customer and operated in the windows to control the EUT's continuous transmission.

## *Appendix B*

The antenna of the device is build-in inside the PCB of device, the user can not remove it freely without any tools from outside the device. This is comply with the FCC rules part 15.203