



FCC TEST REPORT

REPORT NO.: RF960926L03

MODEL NO.: CM422

RECEIVED: Sep. 26, 2007

TESTED: Oct. 01 ~ Oct. 04, 2007

ISSUED: Oct. 11, 2007

APPLICANT: EVERSPRING INDUSTRY CO., LTD

ADDRESS: 7F, No. 609 Wan Shou Road Sec.1, Kweishan,
Taoyuan Hsien 333, Taiwan, R.O.C.

ISSUED BY: Advance Data Technology Corporation

LAB ADDRESS: No. 47, 14th Ling, Chia Pau Tsuen, Lin Kou Hsiang
244, Taipei Hsien, Taiwan, R.O.C.

TEST LOCATION: No. 19, Hwa Ya 2nd Rd., Wen Hwa Tsuen, Kwei
Shan Hsiang, Taoyuan Hsien 333, Taiwan, R.O.C.

This test report consists of 55 pages in total. It may be duplicated completely for legal use with the approval of the applicant. It should not be reproduced except in full, without the written approval of our laboratory. The client should not use it to claim product endorsement by TAF, A2LA or any government agencies. The test results in the report only apply to the tested sample.





TABLE OF CONTENTS

1.	CERTIFICATION	4
2.	SUMMARY OF TEST RESULTS	5
2.1	MEASUREMENT UNCERTAINTY	5
3.	GENERAL INFORMATION.....	6
3.1	GENERAL DESCRIPTION OF EUT	6
3.2	DESCRIPTION OF TEST MODES.....	7
3.2.1	CONFIGURATION OF SYSTEM UNDER TEST	7
3.2.2	TEST MODE APPLICABILITY AND TESTED CHANNEL DETAIL.....	8
3.2.3	GENERAL DESCRIPTION OF APPLIED STANDARDS	10
3.2.4	DESCRIPTION OF SUPPORT UNITS	10
4.	TEST TYPES AND RESULTS	11
4.1	CONDUCTED EMISSION MEASUREMENT	11
4.1.1	LIMITS OF CONDUCTED EMISSION MEASUREMENT	11
4.1.2	TEST INSTRUMENTS.....	11
4.1.3	TEST PROCEDURES	12
4.1.4	DEVIATION FROM TEST STANDARD	12
4.1.5	TEST SETUP.....	13
4.1.6	EUT OPERATING CONDITIONS	13
4.1.7	TEST RESULTS	14
4.2	RADIATED EMISSION MEASUREMENT	20
4.2.1	LIMITS OF RADIATED EMISSION MEASUREMENT.....	20
4.2.2	TEST INSTRUMENTS	21
4.2.3	TEST PROCEDURES	22
4.2.4	DEVIATION FROM TEST STANDARD	22
4.2.5	TEST SETUP	23
4.2.6	EUT OPERATING CONDITIONS	23
4.2.7	TEST RESULTS	24
4.3	NUMBER OF HOPPING FREQUENCY USED	30
4.3.1	LIMIT OF HOPPING FREQUENCY USED	30
4.3.2	TEST INSTRUMENTS	30
4.3.3	TEST PROCEDURES	30
4.3.4	DEVIATION FROM TEST STANDARD	31
4.3.5	TEST SETUP	31
4.3.6	TEST RESULTS	31
4.4	DWELL TIME ON EACH CHANNEL	33
4.4.1	LIMIT OF DWELL TIME USED.....	33
4.4.2	TEST INSTRUMENTS	33
4.4.3	TEST PROCEDURES	33
4.4.4	DEVIATION FROM TEST STANDARD	33
4.4.5	TEST SETUP	34
4.4.6	TEST RESULTS	34
4.5	CHANNEL BANDWIDTH.....	36
4.5.1	LIMITS OF CHANNEL BANDWIDTH	36
4.5.2	TEST INSTRUMENTS	36
4.5.3	TEST PROCEDURE	36
4.5.4	DEVIATION FROM TEST STANDARD	37
4.5.5	TEST SETUP	37
4.5.6	EUT OPERATING CONDITION	37
4.5.7	TEST RESULTS	37



4.6	HOPPING CHANNEL SEPARATION	40
4.6.1	LIMIT OF HOPPING CHANNEL SEPARATION	40
4.6.2	TEST INSTRUMENTS	40
4.6.3	TEST PROCEDURES	40
4.6.4	DEVIATION FROM TEST STANDARD	40
4.6.5	TEST SETUP	40
4.6.6	TEST RESULTS	41
4.7	MAXIMUM PEAK OUTPUT POWER	44
4.7.1	LIMITS OF MAXIMUM PEAK OUTPUT POWER MEASUREMENT	44
4.7.2	TEST INSTRUMENTS	44
4.7.3	TEST PROCEDURES	44
4.7.4	DEVIATION FROM TEST STANDARD	44
4.7.5	TEST SETUP	45
4.7.6	EUT OPERATING CONDITION	45
4.7.7	TEST RESULTS	45
4.8	BAND EDGES MEASUREMENT	48
4.8.1	LIMITS OF BAND EDGES MEASUREMENT	48
4.8.2	TEST INSTRUMENTS	48
4.8.3	TEST PROCEDURE	48
4.8.4	DEVIATION FROM TEST STANDARD	48
4.8.5	EUT OPERATING CONDITION	48
4.8.6	TEST RESULTS	49
4.9	ANTENNA REQUIREMENT	52
4.9.1	STANDARD APPLICABLE	52
4.9.2	ANTENNA CONNECTED CONSTRUCTION	52
5.	PHOTOGRAPHS OF THE TEST CONFIGURATION.....	53
6.	INFORMATION ON THE TESTING LABORATORIES	54
7.	APPENDIX A – MODIFICATIONS RECORDERS FOR ENGINEERING CHANGES TO THE EUT BY THE LAB.....	55



1. CERTIFICATION

PRODUCT: Baby Monitor
MODEL: CM422
BRAND: Everspring
APPLICANT: EVERSPRING INDUSTRY CO., LTD
TESTED: Oct. 01 ~ Oct. 04, 2007
TEST SAMPLE: ENGINEERING SAMPLE
STANDARDS: **FCC Part 15, Subpart C (Section 15.247)**
ANSI C63.4-2003

The above equipment (Model: CM422) have been tested by **Advance Data Technology Corporation**, and found compliance with the requirement of the above standards. The test record, data evaluation & Equipment Under Test (EUT) configurations represented herein are true and accurate accounts of the measurements of the sample's EMC characteristics under the conditions specified in this report.

PREPARED BY : Peggy Chen , **DATE:** Oct. 11, 2007
Peggy Chen / Specialist

TECHNICAL ACCEPTANCE : Long Chen , **DATE:** Oct. 11, 2007
Responsible for RF Long Chen / Senior Engineer

APPROVED BY : Gary Chang , **DATE:** Oct. 11, 2007
Gary Chang / Assistant Manager

2. SUMMARY OF TEST RESULTS

The EUT has been tested according to the following specifications:

APPLIED STANDARD: FCC Part 15, Subpart C			
STANDARD SECTION	TEST TYPE AND LIMIT	RESULT	REMARK
15.207	AC Power Conducted Emission	PASS	Meet the requirement of limit. Minimum passing margin is -18.65dB at 0.478MHz.
15.247(a)(1)(iii)	Number of Hopping Frequency Used Spec.: At least 15 channels	PASS	Meet the requirement of limit.
15.247(a)(1)(iii)	Dwell Time on Each Channel Spec.: Max. 0.4 second within 6 second	PASS	Meet the requirement of limit.
15.247(a)(1)	1. Hopping Channel Separation Spec.: Min. 25 kHz or 20 dB bandwidth, whichever is greater 2. Spectrum Bandwidth of a Frequency Hopping Sequence Spread Spectrum System	PASS	Meet the requirement of limit.
15.247(b)	Maximum Peak Output Power Spec.: max. 21dBm	PASS	Meet the requirement of limit.
15.247(d)	Transmitter Radiated Emissions Spec.: Table 15.209	PASS	Meet the requirement of limit. Minimum passing margin is -1.10dB at 7415.82MHz.
15.247(d)	Band Edge Measurement	PASS	Meet the requirement of limit.

2.1 MEASUREMENT UNCERTAINTY

Where relevant, the following measurement uncertainty levels have been estimated for tests performed on the EUT as specified in CISPR 16-4-2:

MEASUREMENT	FREQUENCY	UNCERTAINTY
Conducted emissions	9kHz~30MHz	2.44 dB
Radiated emissions	30MHz ~ 200MHz	3.19 dB
	200MHz ~1000MHz	3.21 dB
	1GHz ~ 18GHz	2.26 dB
	18GHz ~ 40GHz	1.94 dB

This uncertainty represents an expanded uncertainty expressed at approximately the 95% confidence level using a coverage factor of k=2.

3. GENERAL INFORMATION

3.1 GENERAL DESCRIPTION OF EUT

PRODUCT	Baby Monitor
MODEL NO.	CM422
FCC ID	FU5CM422
POWER SUPPLY	6.0Vdc from AC adapter 6.0Vdc from battery (1.5Vdc*4)
MODULATION TYPE	FSK
RADIO TECHNOLOGY	FHSS
TRANSFER RATE	1.5Mbps
FREQUENCY RANGE	2400.0 ~ 2483.5MHz
NUMBER OF CHANNEL	32
OUTPUT POWER	2.265mW
ANTENNA TYPE	Dipole antenna with 2dBi gain
DATA CABLE	NA
I/O PORTS	Refer to User's Manual
ACCESSORY DEVICES	Adapter

NOTE:

1. The EUT was powered by the following adapter:

BRAND:	MAW WOEI
MODEL:	MW41-0600500R
INPUT:	120Vac, 60Hz, 8.2W
OUTPUT:	6Vdc, 500mA
POWER LINE:	1.8m non-shielded cable with two cores

2. The product specification showed 32 channels are available, but only 15 channels will be used in normal.
3. The above EUT information was declared by manufacturer and for more detailed features description, please refer to the manufacturer's specifications or User's Manual.

3.2 DESCRIPTION OF TEST MODES

32 channels are provided to this EUT:

CHANNEL	FREQ. (MHz)	CHANNEL	FREQ. (MHz)	CHANNEL	FREQ. (MHz)	CHANNEL	FREQ. (MHz)
0	2404.35	8	2422.78	16	2441.22	24	2457.60
1	2406.40	9	2424.83	17	2443.26	25	2459.65
2	2410.50	10	2426.88	18	2445.31	26	2461.70
3	2412.54	11	2428.93	19	2447.36	27	2463.74
4	2414.59	12	2430.98	20	2449.41	28	2465.79
5	2416.64	13	2433.02	21	2451.46	29	2467.84
6	2418.69	14	2435.07	22	2453.50	30	2469.89
7	2420.74	15	2437.12	23	2455.55	31	2471.94

3.2.1 CONFIGURATION OF SYSTEM UNDER TEST

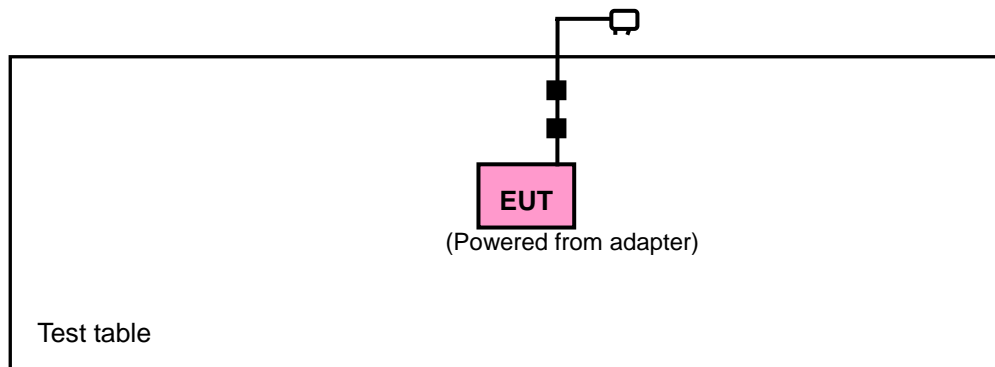

3.2.2 TEST MODE APPLICABILITY AND TESTED CHANNEL DETAIL

EUT CONFIGURE MODE	Applicable to				Description
	PLC	RE<1G	RE≥1G	APCM	
-	√	√	√	√	-

Where **PLC**: Power Line Conducted Emission **RE<1G**: Radiated Emission below 1GHz
RE≥1G: Radiated Emission above 1GHz **APCM**: Antenna Port Conducted Measurement

Power Line Conducted Emission Test:

- Pre-Scan has been conducted to determine the worst-case mode from all possible combinations between available modulations and antenna ports (if EUT with antenna diversity architecture).
- Following channel(s) was (were) selected for the final test as listed below.

EUT CONFIGURE MODE	AVAILABLE CHANNEL	TESTED CHANNEL	MODULATION TECHNOLOGY	MODULATION TYPE
-	0 to 31	0, 16, 31	FHSS	FSK

RADIATED EMISSION TEST (BELOW 1 GHz):

- Pre-Scan has been conducted to determine the worst-case mode from all possible combinations between available modulations, XYZ axis and antenna ports (if EUT with antenna diversity architecture).
- Following channel(s) was (were) selected for the final test as listed below.

EUT CONFIGURE MODE	AVAILABLE CHANNEL	TESTED CHANNEL	MODULATION TECHNOLOGY	MODULATION TYPE	AXIS
-	0 to 31	31	FHSS	FSK	Z

RADIATED EMISSION TEST (ABOVE 1 GHz):

- Pre-Scan has been conducted to determine the worst-case mode from all possible combinations between available modulations, XYZ axis and antenna ports (if EUT with antenna diversity architecture).
- Following channel(s) was (were) selected for the final test as listed below.

EUT CONFIGURE MODE	AVAILABLE CHANNEL	TESTED CHANNEL	MODULATION TECHNOLOGY	MODULATION TYPE	AXIS
-	0 to 31	0, 16, 31	FHSS	FSK	Z



BANDEDGE MEASUREMENT:

- Pre-Scan has been conducted to determine the worst-case mode from all possible combinations between available modulations and packet types.
- Following channel(s) was (were) selected for the final test as listed below.

AVAILABLE CHANNEL	TESTED CHANNEL	MODULATION TECHNOLOGY	MODULATION TYPE
0 to 31	0, 31	FHSS	FSK

ANTENNA PORT CONDUCTED MEASUREMENT:

- Pre-Scan has been conducted to determine the worst-case mode from all possible combinations between available modulations and packet types.
- Following channel(s) was (were) selected for the final test as listed below.

AVAILABLE CHANNEL	TESTED CHANNEL	MODULATION TECHNOLOGY	MODULATION TYPE
0 to 31	0, 16, 31	FHSS	FSK



3.2.3 GENERAL DESCRIPTION OF APPLIED STANDARDS

The EUT is a RF Product. According to the specifications of the manufacturer, it must comply with the requirements of the following standards:

FCC Part 15, Subpart C. (15.247)
ANSI C63.4- 2003

All test items have been performed and recorded as per the above standards.

NOTE: The EUT is also considered as a kind of computer peripheral, because the connection to computer is necessary for typical use. It has been verified to comply with the requirements of FCC Part 15, Subpart B, Class B (DoC). The test report has been issued separately.

3.2.4 DESCRIPTION OF SUPPORT UNITS

The EUT has been tested as an independent unit.

4. TEST TYPES AND RESULTS

4.1 CONDUCTED EMISSION MEASUREMENT

4.1.1 LIMITS OF CONDUCTED EMISSION MEASUREMENT

FREQUENCY OF EMISSION (MHz)	CONDUCTED LIMIT (dB μ V)	
	Quasi-peak	Average
0.15 ~ 0.5	66 to 56	56 to 46
0.5 ~ 5	56	46
5 ~ 30	60	50

- NOTE:**
1. The lower limit shall apply at the transition frequencies.
 2. The limit decreases in line with the logarithm of the frequency in the range of 0.15 to 0.50 MHz.
 3. All emanations from a class A/B digital device or system, including any network of conductors and apparatus connected thereto, shall not exceed the level of field strengths specified above.

4.1.2 TEST INSTRUMENTS

DESCRIPTION & MANUFACTURER	MODEL NO.	SERIAL NO.	CALIBRATED UNTIL
Test Receiver ROHDE & SCHWARZ	ESCS30	100289	Dec. 08, 2007
RF signal cable Woken	5D-FB	Cable-HYCO3-01	Jan. 06, 2008
LISN ROHDE & SCHWARZ	ESH2-Z5	100100	Jan. 08, 2008
LISN ROHDE & SCHWARZ	ESH3-Z5	100311	Jan. 16, 2008
Software ADT	ADT_Cond_V3	NA	NA

- NOTE:**
1. The calibration interval of the above test instruments is 12 months and the calibrations are traceable to NML/ROC and NIST/USA.
 2. The test was performed in HwaYa Shielded Room 2.
 3. The VCCI Site Registration No. is C-2047.

4.1.3 TEST PROCEDURES

- a. The EUT was placed 0.4 meters from the conducting wall of the shielded room with EUT being connected to the power mains through a line impedance stabilization network (LISN). Other support units were connected to the power mains through another LISN. The two LISNs provide 50 ohm/ 50uH of coupling impedance for the measuring instrument.
- b. Both lines of the power mains connected to the EUT were checked for maximum conducted interference.
- c. The frequency range from 150kHz to 30MHz was searched. Emission levels under (Limit - 20dB) was not recorded.

4.1.4 DEVIATION FROM TEST STANDARD

No deviation

4.1.5 TEST SETUP

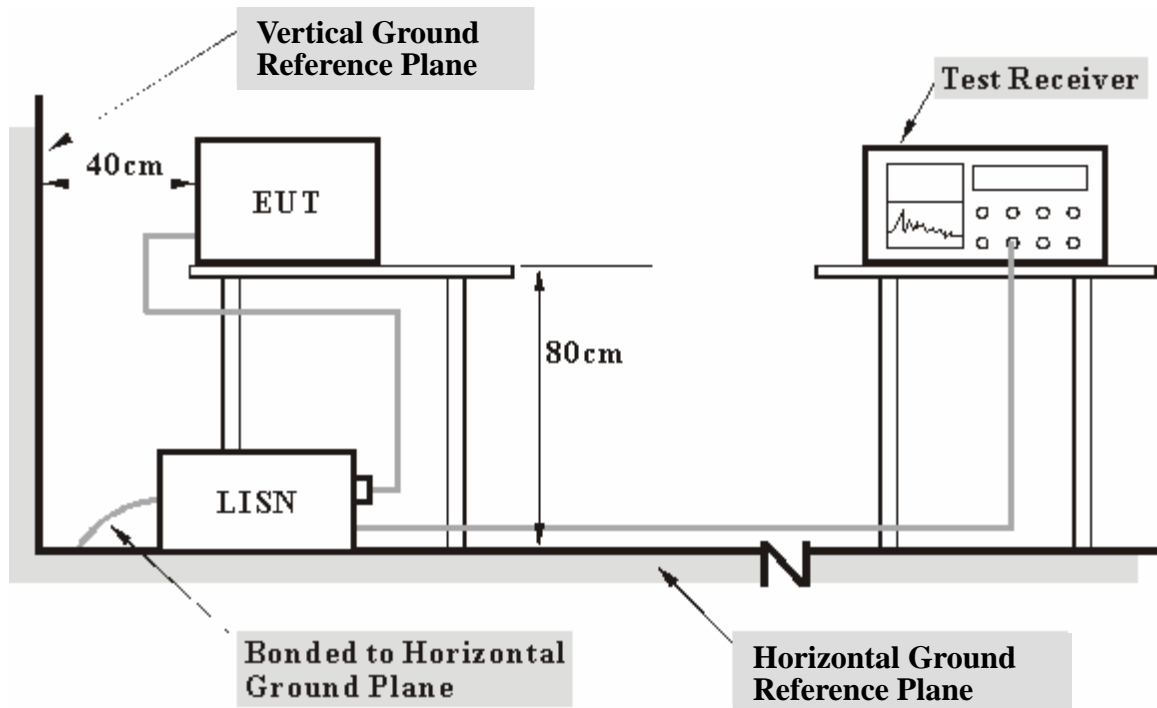

- Note:**
1. Support units were connected to second LISN.
 2. Both of LISNs (AMN) 80 cm from EUT and at the least 80 cm from other units and other metal planes support units.

For the actual test configuration, please refer to the attached file (Test Setup Photo).

4.1.6 EUT OPERATING CONDITIONS

- a. Placed the EUT on testing table.
- b. Set the EUT under transmission condition continuously at specific channel frequency.

4.1.7 TEST RESULTS

CONDUCTED WORST CASE DATA:

EUT TEST CONDITION		MEASUREMENT DETAIL	
CHANNEL	Channel 0	PHASE	Line 1
MODULATION TYPE	FSK	6dB BANDWIDTH	9 kHz
ENVIRONMENTAL CONDITIONS	20 deg. C, 60%RH, 991hPa	INPUT POWER	120Vac, 60 Hz
TESTED BY	Match Tsui		

No	Freq. [MHz]	Corr. Factor (dB)	Reading Value		Emission Level		Limit		Margin	
			[dB (uV)]		[dB (uV)]		[dB (uV)]		(dB)	
			Q.P.	AV.	Q.P.	AV.	Q.P.	AV.	Q.P.	AV.
1	0.341	0.10	38.14	-	38.24	-	59.17	49.17	-20.93	-
2	0.482	0.10	37.30	-	37.40	-	56.30	46.30	-18.90	-
3	0.705	0.11	33.42	-	33.53	-	56.00	46.00	-22.47	-
4	1.402	0.15	20.29	-	20.44	-	56.00	46.00	-35.56	-
5	12.000	0.39	28.16	-	28.55	-	60.00	50.00	-31.45	-
6	24.000	0.77	18.81	-	19.58	-	60.00	50.00	-40.42	-

- REMARKS:**
1. Q.P. and AV. are abbreviations of quasi-peak and average individually.
 2. "-": The Quasi-peak reading value also meets average limit and measurement with the average detector is unnecessary.
 3. The emission levels of other frequencies were very low against the limit.
 4. Margin value = Emission level - Limit value
 5. Correction factor = Insertion loss + Cable loss
 6. Emission Level = Correction Factor + Reading Value.

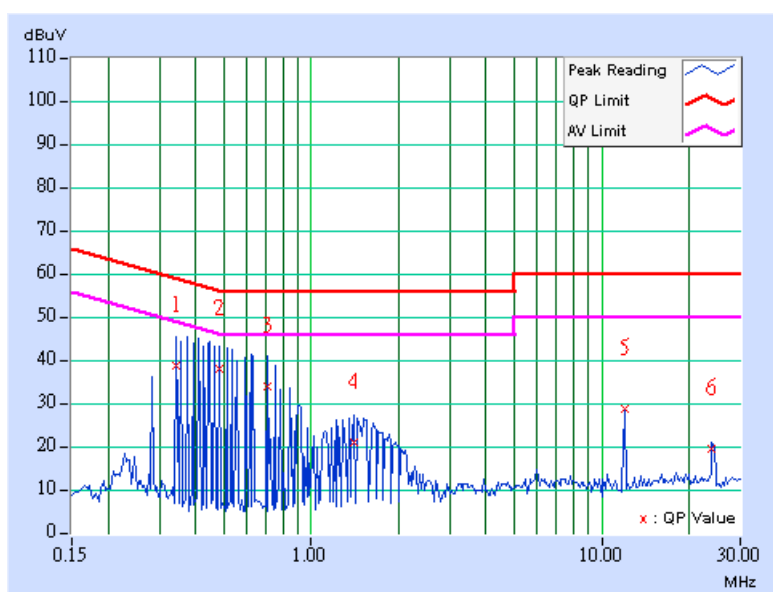

EUT TEST CONDITION		MEASUREMENT DETAIL	
CHANNEL	Channel 0	PHASE	Line 2
MODULATION TYPE	FSK	6dB BANDWIDTH	9 kHz
ENVIRONMENTAL CONDITIONS	20 deg. C, 60%RH, 991hPa	INPUT POWER	120Vac, 60 Hz
TESTED BY	Match Tsui		

No	Freq. [MHz]	Corr. Factor (dB)	Reading Value		Emission Level		Limit		Margin	
			[dB (uV)]		[dB (uV)]		[dB (uV)]		(dB)	
			Q.P.	AV.	Q.P.	AV.	Q.P.	AV.	Q.P.	AV.
1	0.220	0.10	41.34	-	41.44	-	62.81	52.81	-21.37	-
2	0.279	0.10	37.43	-	37.53	-	60.85	50.85	-23.32	-
3	0.384	0.10	36.59	-	36.69	-	58.18	48.18	-21.49	-
4	0.642	0.14	30.90	-	31.04	-	56.00	46.00	-24.96	-
5	12.000	0.45	29.54	-	29.99	-	60.00	50.00	-30.01	-
6	24.000	0.69	20.66	-	21.35	-	60.00	50.00	-38.65	-

- REMARKS:**
1. Q.P. and AV. are abbreviations of quasi-peak and average individually.
 2. "-": The Quasi-peak reading value also meets average limit and measurement with the average detector is unnecessary.
 3. The emission levels of other frequencies were very low against the limit.
 4. Margin value = Emission level - Limit value
 5. Correction factor = Insertion loss + Cable loss
 6. Emission Level = Correction Factor + Reading Value.

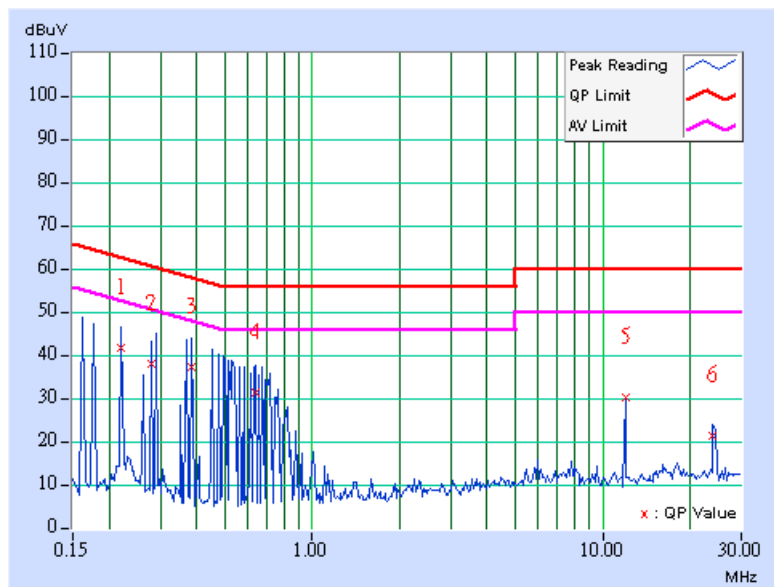

EUT TEST CONDITION		MEASUREMENT DETAIL	
CHANNEL	Channel 16	PHASE	Line 1
MODULATION TYPE	FSK	6dB BANDWIDTH	9 kHz
ENVIRONMENTAL CONDITIONS	20 deg. C, 60%RH, 991hPa	INPUT POWER	120Vac, 60 Hz
TESTED BY	Match Tsui		

No	Freq. [MHz]	Corr. Factor (dB)	Reading Value		Emission Level		Limit		Margin	
			[dB (uV)]		[dB (uV)]		[dB (uV)]		(dB)	
			Q.P.	AV.	Q.P.	AV.	Q.P.	AV.	Q.P.	AV.
1	0.193	0.10	42.40	-	42.50	-	63.91	53.91	-21.41	-
2	0.283	0.10	38.74	-	38.84	-	60.73	50.73	-21.89	-
3	0.709	0.11	32.19	-	32.30	-	56.00	46.00	-23.70	-
4	1.391	0.15	19.51	-	19.66	-	56.00	46.00	-36.34	-
5	12.000	0.39	28.20	-	28.59	-	60.00	50.00	-31.41	-
6	24.574	0.80	18.80	-	19.60	-	60.00	50.00	-40.40	-

- REMARKS:**
1. Q.P. and AV. are abbreviations of quasi-peak and average individually.
 2. "-": The Quasi-peak reading value also meets average limit and measurement with the average detector is unnecessary.
 3. The emission levels of other frequencies were very low against the limit.
 4. Margin value = Emission level - Limit value
 5. Correction factor = Insertion loss + Cable loss
 6. Emission Level = Correction Factor + Reading Value.

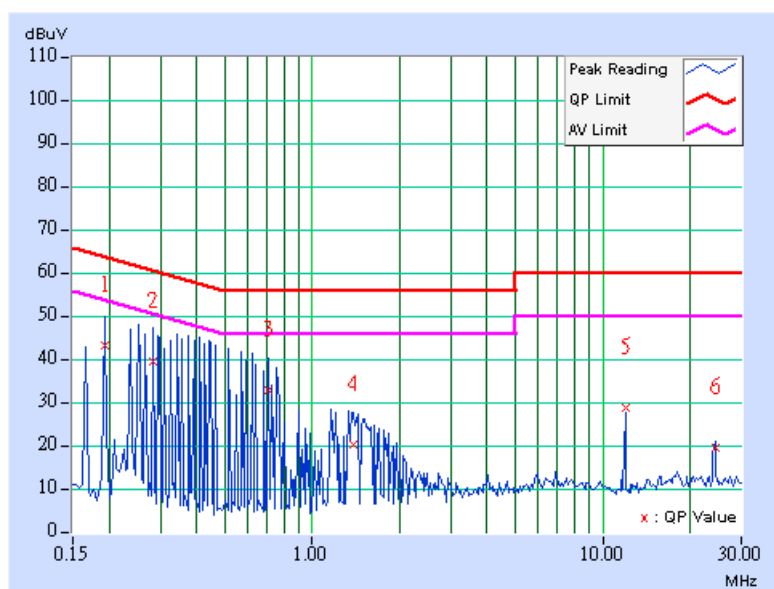

EUT TEST CONDITION		MEASUREMENT DETAIL	
CHANNEL	Channel 16	PHASE	Line 2
MODULATION TYPE	FSK	6dB BANDWIDTH	9 kHz
ENVIRONMENTAL CONDITIONS	20 deg. C, 60%RH, 991hPa	INPUT POWER	120Vac, 60 Hz
TESTED BY	Match Tsui		

No	Freq. [MHz]	Corr. Factor (dB)	Reading Value		Emission Level		Limit		Margin	
			[dB (uV)]		[dB (uV)]		[dB (uV)]		(dB)	
			Q.P.	AV.	Q.P.	AV.	Q.P.	AV.	Q.P.	AV.
1	0.197	0.10	41.75	-	41.85	-	63.74	53.74	-21.89	-
2	0.302	0.10	36.62	-	36.72	-	60.18	50.18	-23.46	-
3	0.560	0.13	31.99	-	32.12	-	56.00	46.00	-23.88	-
4	0.689	0.15	29.12	-	29.27	-	56.00	46.00	-26.73	-
5	12.000	0.45	29.60	-	30.05	-	60.00	50.00	-29.95	-
6	24.000	0.69	20.76	-	21.45	-	60.00	50.00	-38.55	-

- REMARKS:**
1. Q.P. and AV. are abbreviations of quasi-peak and average individually.
 2. "-": The Quasi-peak reading value also meets average limit and measurement with the average detector is unnecessary.
 3. The emission levels of other frequencies were very low against the limit.
 4. Margin value = Emission level - Limit value
 5. Correction factor = Insertion loss + Cable loss
 6. Emission Level = Correction Factor + Reading Value.

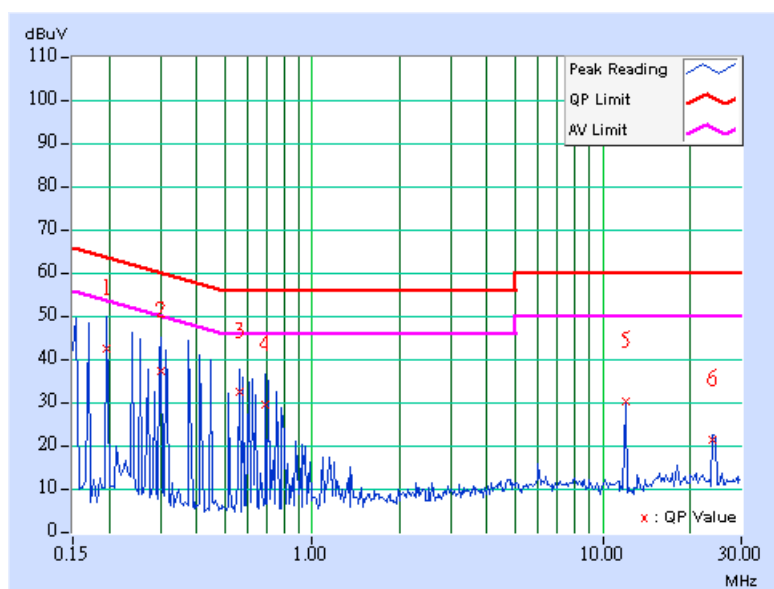

EUT TEST CONDITION		MEASUREMENT DETAIL	
CHANNEL	Channel 31	PHASE	Line 1
MODULATION TYPE	FSK	6dB BANDWIDTH	9 kHz
ENVIRONMENTAL CONDITIONS	20 deg. C, 60%RH, 991hPa	INPUT POWER	120Vac, 60 Hz
TESTED BY	Match Tsui		

No	Freq. [MHz]	Corr. Factor (dB)	Reading Value		Emission Level		Limit		Margin	
			[dB (uV)]		[dB (uV)]		[dB (uV)]		(dB)	
			Q.P.	AV.	Q.P.	AV.	Q.P.	AV.	Q.P.	AV.
1	0.177	0.10	43.29	-	43.39	-	64.61	54.61	-21.22	-
2	0.263	0.10	39.79	-	39.89	-	61.33	51.33	-21.44	-
3	0.478	0.10	37.62	-	37.72	-	56.37	46.37	-18.65	-
4	1.133	0.12	19.89	-	20.01	-	56.00	46.00	-35.99	-
5	12.000	0.39	28.22	-	28.61	-	60.00	50.00	-31.39	-
6	24.574	0.80	18.86	-	19.66	-	60.00	50.00	-40.34	-

- REMARKS:**
1. Q.P. and AV. are abbreviations of quasi-peak and average individually.
 2. "-": The Quasi-peak reading value also meets average limit and measurement with the average detector is unnecessary.
 3. The emission levels of other frequencies were very low against the limit.
 4. Margin value = Emission level - Limit value
 5. Correction factor = Insertion loss + Cable loss
 6. Emission Level = Correction Factor + Reading Value.

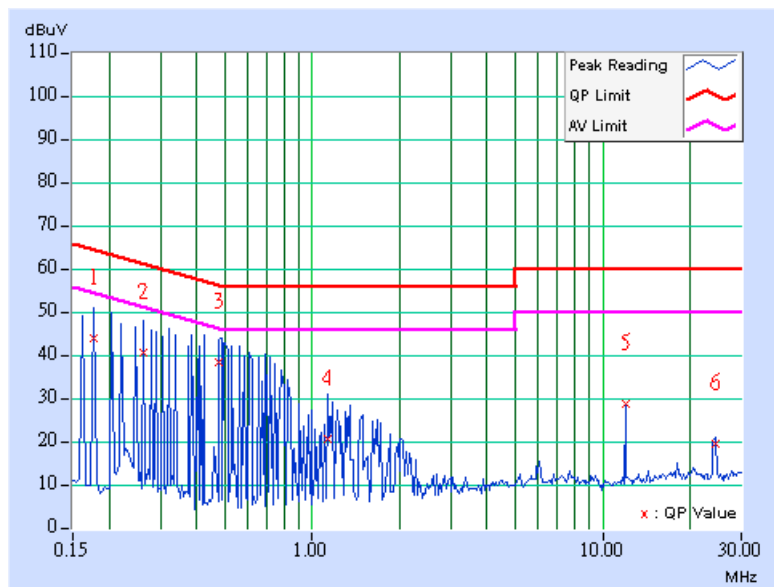

EUT TEST CONDITION		MEASUREMENT DETAIL	
CHANNEL	Channel 31	PHASE	Line 2
MODULATION TYPE	FSK	6dB BANDWIDTH	9 kHz
ENVIRONMENTAL CONDITIONS	20 deg. C, 60%RH, 991hPa	INPUT POWER	120Vac, 60 Hz
TESTED BY	Match Tsui		

No	Freq. [MHz]	Corr. Factor (dB)	Reading Value		Emission Level		Limit		Margin	
			[dB (uV)]		[dB (uV)]		[dB (uV)]		(dB)	
			Q.P.	AV.	Q.P.	AV.	Q.P.	AV.	Q.P.	AV.
1	0.197	0.10	41.85	-	41.95	-	63.74	53.74	-21.79	-
2	0.271	0.10	38.09	-	38.19	-	61.08	51.08	-22.89	-
3	0.490	0.12	34.56	-	34.68	-	56.17	46.17	-21.49	-
4	0.685	0.15	28.69	-	28.84	-	56.00	46.00	-27.16	-
5	12.000	0.45	29.66	-	30.11	-	60.00	50.00	-29.89	-
6	24.574	0.71	21.95	-	22.66	-	60.00	50.00	-37.34	-

- REMARKS:**
1. Q.P. and AV. are abbreviations of quasi-peak and average individually.
 2. "-": The Quasi-peak reading value also meets average limit and measurement with the average detector is unnecessary.
 3. The emission levels of other frequencies were very low against the limit.
 4. Margin value = Emission level - Limit value
 5. Correction factor = Insertion loss + Cable loss
 6. Emission Level = Correction Factor + Reading Value.

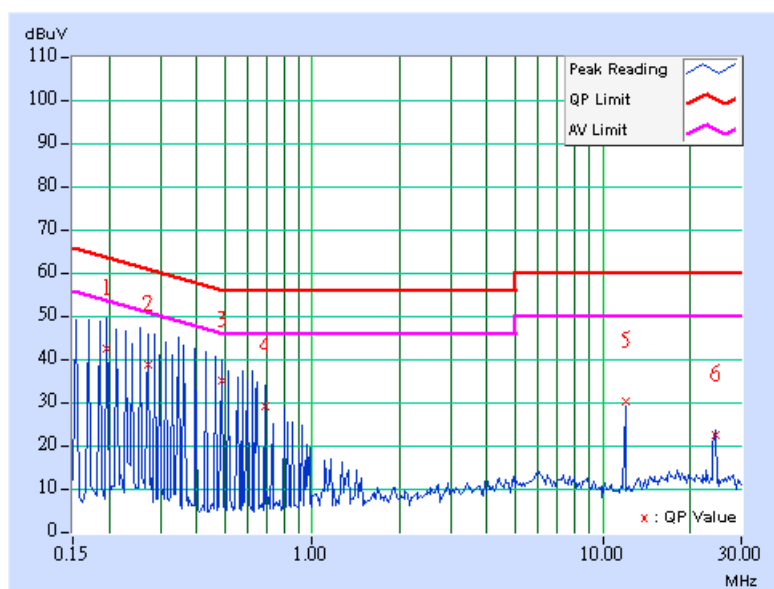

4.2 RADIATED EMISSION MEASUREMENT

4.2.1 LIMITS OF RADIATED EMISSION MEASUREMENT

Emissions radiated outside of the specified bands, shall be according to the general radiated limits in 15.209 as following:

FREQUENCIES (MHz)	FIELD STRENGTH (microvolts/meter)	MEASUREMENT DISTANCE (meters)
0.009 ~ 0.490	2400/F(kHz)	300
0.490 ~ 1.705	24000/F(kHz)	30
1.705 ~ 30.0	30	30
30 ~ 88	100	3
88 ~ 216	150	3
216 ~ 960	200	3
Above 960	500	3

NOTE:

1. The lower limit shall apply at the transition frequencies.
2. Emission level (dBuV/m) = 20 log Emission level (uV/m).
3. As shown in 15.35(b), for frequencies above 1000MHz, the field strength limits are based on average detector, however, the peak field strength of any emission shall not exceed the maximum permitted average limits, specified above by more than 20dB under any condition of modulation.



4.2.2 TEST INSTRUMENTS

DESCRIPTION & MANUFACTURER	MODEL NO.	SERIAL NO.	CALIBRATED UNTIL
Test Receiver ROHDE & SCHWARZ	ESI7	838496/016	Dec. 29, 2007
Spectrum Analyzer ROHDE & SCHWARZ	FSP40	100039	Dec. 01, 2007
BILOG Antenna SCHWARZBECK	VULB9168	9168-155	Jan. 04, 2008
HORN Antenna SCHWARZBECK	BBHA 9120D	9120D-405	Dec. 18, 2007
HORN Antenna SCHWARZBECK	BBHA 9170	BBHA9170242	Jan. 16, 2008
Preamplifier Agilent	8449B	3008A1960	Oct. 30, 2007
Preamplifier Agilent	8447D	2944A10631	Oct. 30, 2007
RF signal cable HUBER+SUHNNER	SUCOFLEX 104	230128/4	Nov. 14, 2007
RF signal cable HUBER+SUHNNER	SUCOFLEX 104	233233/4	Nov. 14, 2007
Software ADT.	ADT_Radiated_V7.6	NA	NA
Antenna Tower inn-co GmbH	MA 4000	010303	NA
Antenna Tower Controller inn-co GmbH	CO2000	019303	NA
Turn Table ADT.	TT100.	TT93021704	NA
Turn Table Controller ADT.	SC100.	SC93021704	NA

- NOTE:**
1. The calibration interval of the above test instruments is 12 months and the calibrations are traceable to NML/ROC and NIST/USA.
 2. The test was performed in HwaYa Chamber 4.
 3. The horn antenna and HP preamplifier (model: 8449B) are used only for the measurement of emission frequency above 1GHz if tested.
 4. The IC Site Registration No. is IC3789B-4.

4.2.3 TEST PROCEDURES

- a. The EUT was placed on the top of a rotating table 0.8 meters above the ground at a 3 meter semi-anechoic chamber. The table was rotated 360 degrees to determine the position of the highest radiation.
- b. The EUT was set 3 meters away from the interference-receiving antenna, which was mounted on the top of a variable-height antenna tower.
- c. The antenna is a broadband antenna, and its height is varied from one meter to four meters above the ground to determine the maximum value of the field strength. Both horizontal and vertical polarizations of the antenna are set to make the measurement.
- d. For each suspected emission, the EUT was arranged to its worst case and then the antenna was tuned to heights from 1 meter to 4 meters and the rotatable table was turned from 0 degrees to 360 degrees to find the maximum reading.
- e. The test-receiver system was set to Peak Detect Function and Specified Bandwidth with Maximum Hold Mode.
- f. If the emission level of the EUT in peak mode was lower than the limit specified, then testing could be stopped and the peak values of the EUT would be reported. Otherwise the emissions would be re-tested one by one using peak, quasi-peak or average method as specified and then reported in a data sheet.

NOTE:

1. The resolution bandwidth and video bandwidth of test receiver/spectrum analyzer is 120kHz for Quasi-peak detection at frequency below 1GHz.
2. The resolution bandwidth of test receiver/spectrum analyzer is 1 MHz and video bandwidth is 3MHz for Peak detection at frequency above 1GHz.

4.2.4 DEVIATION FROM TEST STANDARD

No deviation

4.2.5 TEST SETUP

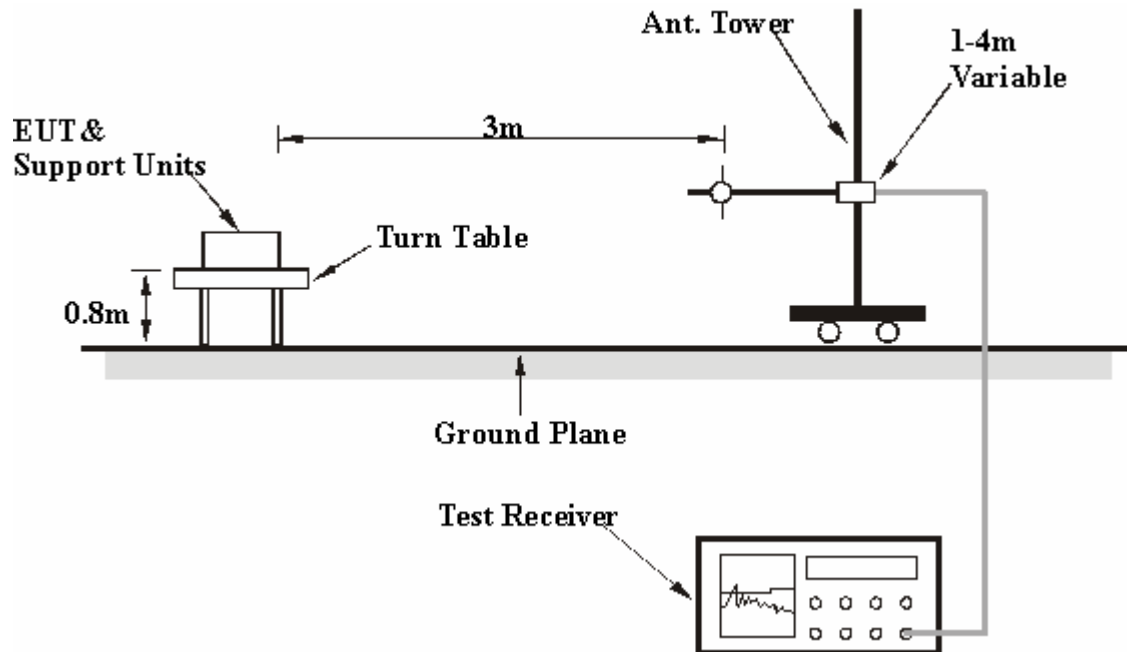

For the actual test configuration, please refer to the attached file (Test Setup Photo).

4.2.6 EUT OPERATING CONDITIONS

Same as item 4.1.6.

4.2.7 TEST RESULTS

Radiated Worst-Case Data: Below 1GHz

EUT TEST CONDITION		MEASUREMENT DETAIL	
CHANNEL	Channel 31	FREQUENCY RANGE	Below 1000MHz
MODULATION TYPE	FSK	DETECTOR FUNCTION	Quasi-Peak
INPUT POWER	120Vac, 60 Hz	ENVIRONMENTAL CONDITIONS	26deg. C, 65%RH, 991hPa
TESTED BY	Kevin Chen		

ANTENNA POLARITY & TEST DISTANCE: HORIZONTAL AT 3 M								
No.	Freq. (MHz)	Emission Level (dBuV/m)	Limit (dBuV/m)	Margin (dB)	Antenna Height (m)	Table Angle (Degree)	Raw Value (dBuV)	Correction Factor (dB/m)
1	61.01	28.29 QP	40.00	-11.71	1.00 H	244	14.59	13.71
2	158.22	32.65 QP	43.50	-10.85	2.00 H	82	18.23	14.42
3	379.87	29.66 QP	46.00	-16.34	1.00 H	250	12.84	16.82
4	601.52	31.12 QP	46.00	-14.88	1.50 H	208	7.95	23.18
5	700.68	34.70 QP	46.00	-11.30	1.00 H	172	9.45	25.26
6	801.78	33.64 QP	46.00	-12.36	1.00 H	58	7.19	26.46

ANTENNA POLARITY & TEST DISTANCE: VERTICAL AT 3 M								
No.	Freq. (MHz)	Emission Level (dBuV/m)	Limit (dBuV/m)	Margin (dB)	Antenna Height (m)	Table Angle (Degree)	Raw Value (dBuV)	Correction Factor (dB/m)
1	61.44	37.55 QP	40.00	-2.45	1.00 V	133	23.92	13.63
2	109.62	32.62 QP	43.50	-10.88	1.00 V	19	21.50	11.12
3	288.49	29.80 QP	46.00	-16.20	2.00 V	277	15.30	14.50
4	453.75	34.26 QP	46.00	-11.74	1.00 V	61	15.24	19.02
5	801.78	34.71 QP	46.00	-11.29	1.50 V	169	8.26	26.46
6	947.60	33.70 QP	46.00	-12.30	2.50 V	313	5.21	28.49

- REMARKS:**
1. Emission level(dBuV/m)=Raw Value(dBuV) + Correction Factor(dB/m)
 2. Correction Factor(dB/m) = Antenna Factor (dB/m) + Cable Factor (dB)
 3. The other emission levels were very low against the limit.
 4. Margin value = Emission level – Limit value.

Radiated Worst-Case Data: Above 1GHz

EUT TEST CONDITION		MEASUREMENT DETAIL	
CHANNEL	Channel 0	FREQUENCY RANGE	1 ~ 25GHz
MODULATION TYPE	FSK	DETECTOR FUNCTION	Peak (PK) Average (AV)
INPUT POWER	120Vac, 60 Hz	ENVIRONMENTAL CONDITIONS	26deg. C, 65%RH, 991hPa
TESTED BY	Kevin Chen		

ANTENNA POLARITY & TEST DISTANCE: HORIZONTAL AT 3 M								
No.	Freq. (MHz)	Emission Level (dBuV/m)	Limit (dBuV/m)	Margin (dB)	Antenna Height (m)	Table Angle (Degree)	Raw Value (dBuV)	Correction Factor (dB/m)
1	2390.00	63.18 PK	74.00	-10.82	1.23 H	170	30.95	32.23
2	2390.00	50.42 AV	54.00	-3.58	1.23 H	170	18.19	32.23
3	*2404.35	100.37 PK			1.00 H	192	68.08	32.29
4	*2404.35	60.37 AV			1.00 H	192	28.08	32.29
5	4808.70	63.74 PK	74.00	-10.26	1.01 H	130	25.31	38.43
6	4808.70	23.74 AV	54.00	-30.26	1.01 H	130	-14.69	38.43
7	7213.05	67.36 PK	74.00	-6.64	1.48 H	41	22.63	44.73
8	7213.05	27.36 AV	54.00	-26.64	1.48 H	41	-17.37	44.73
9	9617.40	66.90 PK	74.00	-7.10	1.37 H	217	19.00	47.90
10	9617.40	26.90 AV	54.00	-27.10	1.37 H	217	-21.00	47.90
11	12021.75	65.45 PK	74.00	-8.55	1.76 H	29	15.09	50.35
12	12021.75	25.45 AV	54.00	-28.55	1.76 H	29	-24.90	50.35

- REMARKS:**
1. Emission level(dBuV/m)=Raw Value(dBuV) + Correction Factor(dB/m).
 2. Correction Factor(dB/m) = Antenna Factor(dB/m) + Cable Factor(dB)
 3. Margin value = Emission level - Limit value
 4. “ * ” : Fundamental Frequency.
 5. The other emission levels were very low against the limit
 6. The duty cycle correction factor be equal to: $20\log(0.5*2/100) = -40.00\text{dB}$
 7. Average value = peak reading + $20\log(\text{duty cycle})$

EUT TEST CONDITION		MEASUREMENT DETAIL	
CHANNEL	Channel 0	FREQUENCY RANGE	1 ~ 25GHz
MODULATION TYPE	FSK	DETECTOR FUNCTION	Peak (PK) Average (AV)
INPUT POWER	120Vac, 60 Hz	ENVIRONMENTAL CONDITIONS	26deg. C, 65%RH, 991hPa
TESTED BY	Kevin Chen		

ANTENNA POLARITY & TEST DISTANCE: VERTICAL AT 3 M								
No.	Freq. (MHz)	Emission Level (dBuV/m)	Limit (dBuV/m)	Margin (dB)	Antenna Height (m)	Table Angle (Degree)	Raw Value (dBuV)	Correction Factor (dB/m)
1	2390.00	66.67 PK	74.00	-7.33	1.44 V	255	34.44	32.23
2	2390.00	50.42 AV	54.00	-3.58	1.44 V	255	18.19	32.23
3	*2404.35	99.86 PK			1.23 V	217	67.57	32.29
4	*2404.35	59.86 AV			1.23 V	217	27.57	32.29
5	4808.70	63.76 PK	74.00	-10.24	1.01 V	18	25.33	38.43
6	4808.70	23.76 AV	54.00	-30.24	1.01 V	18	-14.67	38.43
7	7212.00	61.93 PK	74.00	-12.07	1.29 V	13	17.20	44.73
8	7212.00	21.93 AV	54.00	-32.07	1.29 V	13	-22.80	44.73
9	9617.40	63.72 PK	74.00	-10.28	1.49 V	208	15.82	47.90
10	9617.40	23.72 AV	54.00	-30.28	1.49 V	208	-24.18	47.90
11	12021.75	67.97 PK	74.00	-6.03	1.43 V	356	17.61	50.35
12	12021.75	27.97 AV	54.00	-26.03	1.43 V	356	-22.38	50.35

- REMARKS:**
1. Emission level(dBuV/m)=Raw Value(dBuV) + Correction Factor(dB/m).
 2. Correction Factor(dB/m) = Antenna Factor(dB/m) + Cable Factor(dB)
 3. Margin value = Emission level - Limit value
 4. “ * ” : Fundamental Frequency.
 5. The other emission levels were very low against the limit
 6. The duty cycle correction factor be equal to: $20\log(0.5 \times 2 / 100) = -40.00\text{dB}$
 7. Average value = peak reading + $20\log(\text{duty cycle})$

EUT TEST CONDITION		MEASUREMENT DETAIL	
CHANNEL	Channel 16	FREQUENCY RANGE	1 ~ 25GHz
MODULATION TYPE	FSK	DETECTOR FUNCTION	Peak (PK) Average (AV)
INPUT POWER	120Vac, 60 Hz	ENVIRONMENTAL CONDITIONS	26deg. C, 65%RH, 991hPa
TESTED BY	Kevin Chen		

ANTENNA POLARITY & TEST DISTANCE: HORIZONTAL AT 3 M								
No.	Freq. (MHz)	Emission Level (dBuV/m)	Limit (dBuV/m)	Margin (dB)	Antenna Height (m)	Table Angle (Degree)	Raw Value (dBuV)	Correction Factor (dB/m)
1	*2441.22	99.72 PK			1.54 H	17	67.29	32.43
2	*2441.22	59.72 AV			1.54 H	17	27.29	32.43
3	4882.44	62.80 PK	74.00	-11.20	1.42 H	119	24.07	38.73
4	4882.44	22.80 AV	54.00	-31.20	1.42 H	119	-15.93	38.73
5	7323.66	72.29 PK	74.00	-1.71	1.57 H	150	27.29	45.01
6	7323.66	32.29 AV	54.00	-21.71	1.57 H	150	-12.72	45.01
7	9764.88	68.50 PK	74.00	-5.50	1.50 H	178	20.32	48.18
8	9764.88	28.50 AV	54.00	-25.50	1.50 H	178	-19.68	48.18
9	12206.10	64.46 PK	74.00	-9.54	1.14 H	179	13.75	50.71
10	12206.10	24.46 AV	54.00	-29.54	1.14 H	179	-26.25	50.71

ANTENNA POLARITY & TEST DISTANCE: VERTICAL AT 3 M								
No.	Freq. (MHz)	Emission Level (dBuV/m)	Limit (dBuV/m)	Margin (dB)	Antenna Height (m)	Table Angle (Degree)	Raw Value (dBuV)	Correction Factor (dB/m)
1	*2441.22	98.55 PK			1.42 V	28	66.12	32.43
2	*2441.22	58.55 AV			1.42 V	28	26.12	32.43
3	4882.44	61.77 PK	74.00	-12.23	1.21 V	142	23.04	38.73
4	4882.44	21.77 AV	54.00	-32.23	1.21 V	142	-16.96	38.73
5	7323.66	66.37 PK	74.00	-7.63	1.12 V	184	21.37	45.01
6	7323.66	26.37 AV	54.00	-27.63	1.12 V	184	-18.64	45.01
7	9764.88	65.63 PK	74.00	-8.37	1.60 V	205	17.45	48.18
8	9764.88	25.63 AV	54.00	-28.37	1.60 V	205	-22.55	48.18
9	12206.10	67.00 PK	74.00	-7.00	1.52 V	222	16.29	50.71
10	12206.10	27.00 AV	54.00	-27.00	1.52 V	222	-23.71	50.71

- REMARKS:**
1. Emission level(dBuV/m)=Raw Value(dBuV) + Correction Factor(dB/m).
 2. Correction Factor(dB/m) = Antenna Factor(dB/m) + Cable Factor(dB)
 3. Margin value = Emission level - Limit value
 4. “ * ” : Fundamental Frequency.
 5. The other emission levels were very low against the limit
 6. The duty cycle correction factor be equal to: $20\log(0.5*2/100)=-40.00\text{dB}$
 7. Average value = peak reading + $20\log(\text{duty cycle})$

EUT TEST CONDITION		MEASUREMENT DETAIL	
CHANNEL	Channel 31	FREQUENCY RANGE	1 ~ 25GHz
MODULATION TYPE	FSK	DETECTOR FUNCTION	Peak (PK) Average (AV)
INPUT POWER	120Vac, 60 Hz	ENVIRONMENTAL CONDITIONS	26deg. C, 65%RH, 991hPa
TESTED BY	Kevin Chen		

ANTENNA POLARITY & TEST DISTANCE: HORIZONTAL AT 3 M								
No.	Freq. (MHz)	Emission Level (dBuV/m)	Limit (dBuV/m)	Margin (dB)	Antenna Height (m)	Table Angle (Degree)	Raw Value (dBuV)	Correction Factor (dB/m)
1	*2471.94	99.09 PK			1.45 H	190	66.55	32.54
2	*2471.94	59.09 AV			1.45 H	190	26.55	32.54
3	2483.50	62.99 PK	74.00	-11.01	1.00 H	4	30.40	32.59
4	2483.50	43.87 AV	54.00	-10.13	1.00 H	4	11.28	32.59
5	4943.88	62.64 PK	74.00	-11.36	1.32 H	183	23.76	38.88
6	4943.88	22.64 AV	54.00	-31.36	1.32 H	183	-16.24	38.88
7	7415.82	72.90 PK	74.00	-1.10	1.60 H	153	27.66	45.24
8	7415.82	32.90 AV	54.00	-21.10	1.60 H	153	-12.34	45.24
9	9887.76	70.78 PK	74.00	-3.22	1.54 H	138	22.43	48.35
10	9887.76	30.78 AV	54.00	-23.22	1.54 H	138	-17.57	48.35
11	12359.70	66.09 PK	74.00	-7.91	1.35 H	175	15.11	50.98
12	12359.70	26.09 AV	54.00	-27.91	1.35 H	175	-24.89	50.98

ANTENNA POLARITY & TEST DISTANCE: VERTICAL AT 3 M								
No.	Freq. (MHz)	Emission Level (dBuV/m)	Limit (dBuV/m)	Margin (dB)	Antenna Height (m)	Table Angle (Degree)	Raw Value (dBuV)	Correction Factor (dB/m)
1	*2471.94	98.22 PK			1.54 V	220	65.68	32.54
2	*2471.94	58.22 AV			1.54 V	220	25.68	32.54
3	2483.50	62.75 PK	74.00	-11.25	1.54 V	220	30.16	32.59
4	2483.50	43.76 AV	54.00	-10.24	1.54 V	220	11.17	32.59
5	4943.88	61.98 PK	74.00	-12.02	1.13 V	211	23.10	38.88
6	4943.88	21.98 AV	54.00	-32.02	1.13 V	211	-16.90	38.88
7	7415.82	67.17 PK	74.00	-6.83	1.04 V	205	21.93	45.24
8	7415.82	27.17 AV	54.00	-26.83	1.04 V	205	-18.07	45.24
9	9887.76	68.20 PK	74.00	-5.80	1.70 V	197	19.85	48.35
10	9887.76	28.20 AV	54.00	-25.80	1.70 V	197	-20.15	48.35
11	12359.70	65.67 PK	74.00	-8.33	1.33 V	165	14.69	50.98
12	12359.70	25.67 AV	54.00	-28.33	1.33 V	165	-25.31	50.98

- REMARKS:**
1. Emission level(dBuV/m)=Raw Value(dBuV) + Correction Factor(dB/m).
 2. Correction Factor(dB/m) = Antenna Factor(dB/m) + Cable Factor(dB)
 3. Margin value = Emission level - Limit value
 4. “ * ” : Fundamental Frequency.
 5. The other emission levels were very low against the limit
 6. The duty cycle correction factor be equal to: $20\log(0.5^2/100) = -40.00\text{dB}$
 7. Average value = peak reading + $20\log(\text{duty cycle})$



Ref 107 dB μ V *Att 10 dB RBW 100 kHz Delta 2 [T1]
 *VBW 300 kHz 3.11 dB
 SWT 10 ms 500.000000 μ s

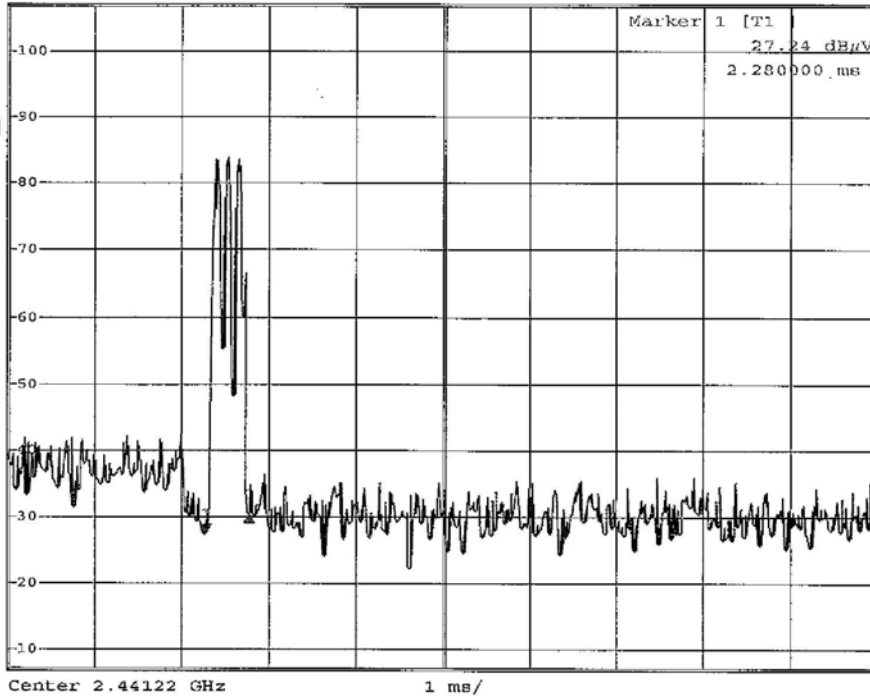

Ref 107 dB μ V *Att 10 dB RBW 100 kHz
 *VBW 300 kHz SWT 100 ms

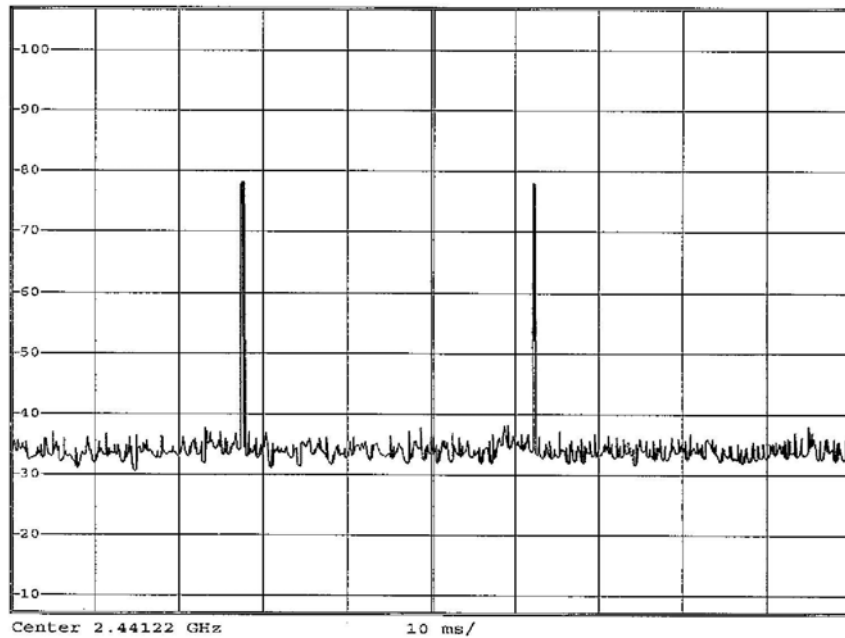

$20\log(0.5 \cdot 2/100) = -40.00$ dB
 Peak reading -40.00 = Average value



4.3 NUMBER OF HOPPING FREQUENCY USED

4.3.1 LIMIT OF HOPPING FREQUENCY USED

At least 15 channels frequencies, and should be equally spaced.

4.3.2 TEST INSTRUMENTS

DESCRIPTION & MANUFACTURER	MODEL NO.	SERIAL NO.	CALIBRATED UNTIL
SPECTRUM ANALYZER	FSP40	100040	Jun. 28, 2008

NOTE: The calibration interval of the above test instruments is 12 months. And the calibrations are traceable to NML/ROC and NIST/USA.

4.3.3 TEST PROCEDURES

- a. Check the calibration of the measuring instrument (SA) using either an internal calibrator or a known signal from an external generator.
- b. Turn on the EUT and connect its antenna terminal to measurement via a low loss cable. Then set it to any one measured frequency within its operating range and make sure the instrument is operated in its linear range.
- c. Set the SA on MaxHold Mode, and then keep the EUT in hopping mode. Record all the signals from each channel until each one has been recorded.
- d. Set the SA on View mode and then plot the result on SA screen.
- e. Repeat above procedures until all frequencies measured were complete.

4.3.4 DEVIATION FROM TEST STANDARD

No deviation.

4.3.5 TEST SETUP

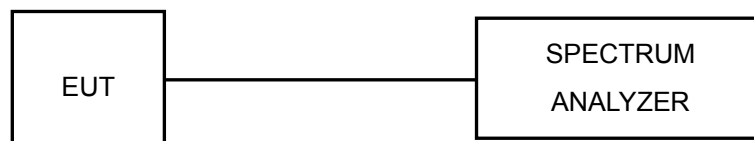

4.3.6 TEST RESULTS

There are 15 hopping frequencies in the hopping mode. Please refer to next page for the test result. On the plots, it shows that the hopping frequencies are equally spaced.

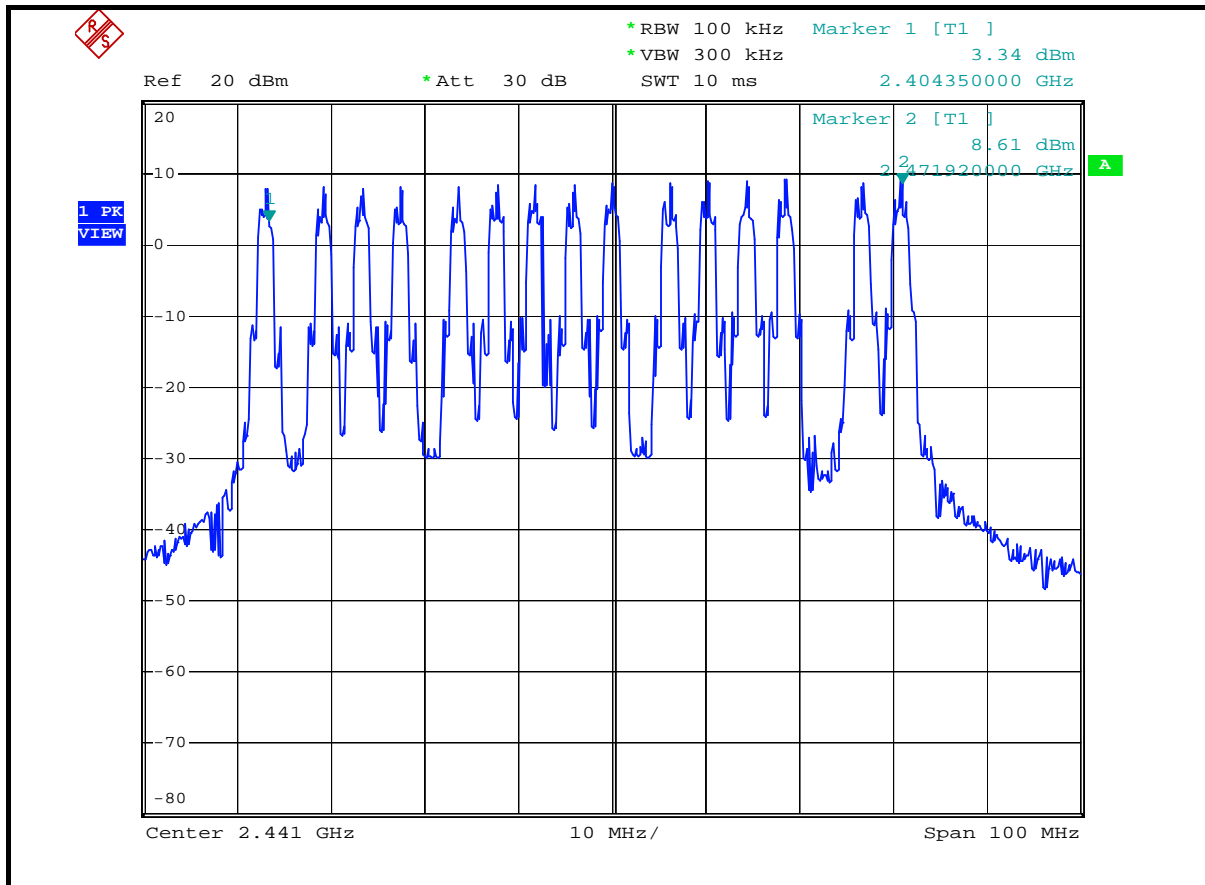



4.4 DWELL TIME ON EACH CHANNEL

4.4.1 LIMIT OF DWELL TIME USED

The average time of occupancy on any channel shall not be greater than 0.4 seconds within a period of 0.4 seconds multiplied by the number of hopping channels employed.

4.4.2 TEST INSTRUMENTS

DESCRIPTION & MANUFACTURER	MODEL NO.	SERIAL NO.	CALIBRATED UNTIL
SPECTRUM ANALYZER	FSP40	100040	Jun. 28, 2008

NOTES: The calibration interval of the above test instruments is 12 months. And the calibrations are traceable to NML/ROC and NIST/USA.

4.4.3 TEST PROCEDURES

- a. Check the calibration of the measuring instrument (SA) using either an internal calibrator or a known signal from an external generator.
- b. Turn on the EUT and connect its antenna terminal to measurement via a low loss cable. Then set it to any one measured frequency within its operating range and make sure the instrument is operated in its linear range.
- c. Adjust the center frequency of SA on any frequency be measured and set SA to zero span mode. And then, set RBW and VBW of spectrum analyzer to proper value.
- d. Measure the time duration of one transmission on the measured frequency. And then plot the result with time difference of this time duration.
- e. Repeat above procedures until all different time-slot modes have been completed.

4.4.4 DEVIATION FROM TEST STANDARD

No deviation.

4.4.5 TEST SETUP

Same as 4.3.5

4.4.6 TEST RESULTS

Number of transmission	Length of transmission time (msec)	Result (msec)	Limit (msec)
73 (times / 6 sec)	0.45	32.850	400

NOTE: Test plots of the transmitting time slot are shown on next pages.

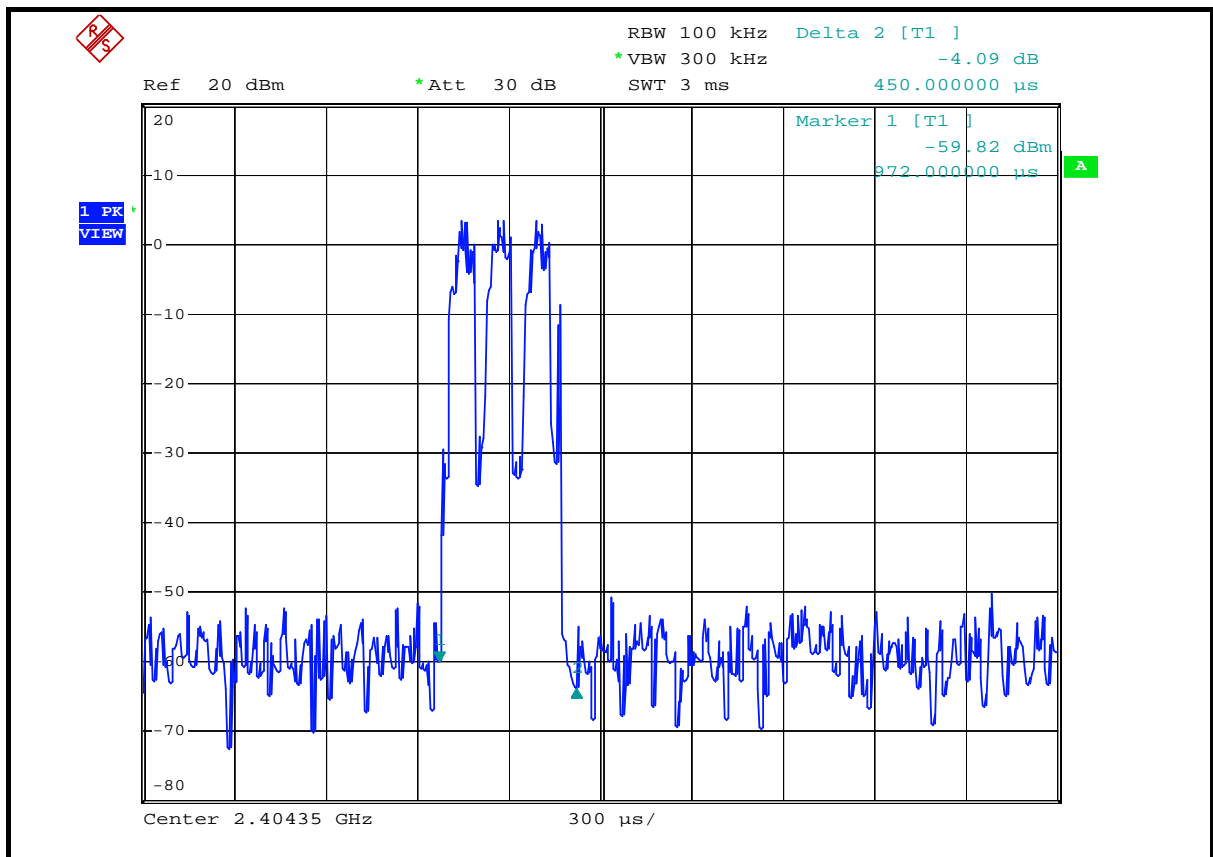
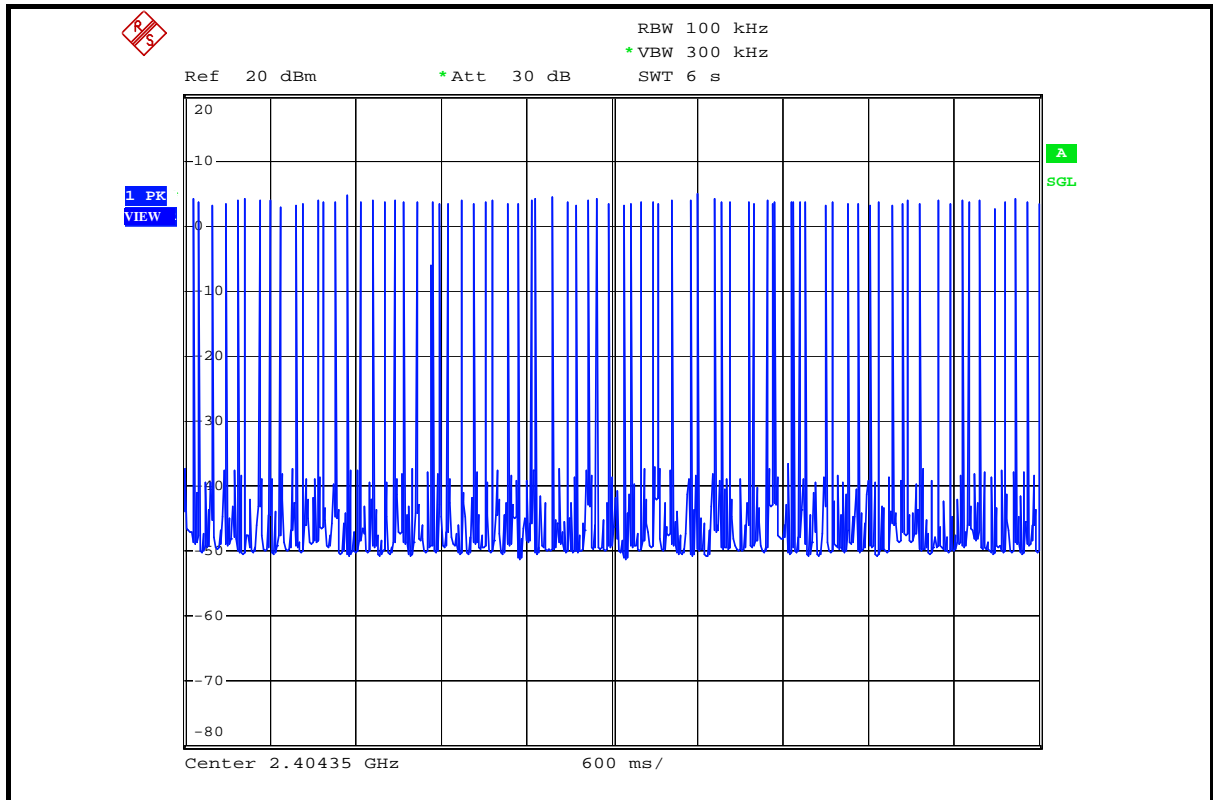



4.5 CHANNEL BANDWIDTH

4.5.1 LIMITS OF CHANNEL BANDWIDTH

For frequency hopping system operating in the 2400-2483.5MHz, if the 20dB bandwidth of hopping channel is greater than 25kHz, the 20dB bandwidth of hopping channel shall be a minimum limit for the hopping channel separation.

4.5.2 TEST INSTRUMENTS

DESCRIPTION & MANUFACTURER	MODEL NO.	SERIAL NO.	CALIBRATED UNTIL
SPECTRUM ANALYZER	FSP40	100040	Jun. 28, 2008

NOTE: The calibration interval of the above test instruments is 12 months. And the calibrations are traceable to NML/ROC and NIST/USA.

4.5.3 TEST PROCEDURE

- a. Check the calibration of the measuring instrument using either an internal calibrator or a known signal from an external generator.
- b. Turn on the EUT and connect it to measurement instrument. Then set it to any one convenient frequency within its operating range. Set a reference level on the measuring instrument equal to the highest peak value.
- c. Measure the frequency difference of two frequencies that were attenuated 20dB from the reference level. Record the frequency difference as the emission bandwidth.
- d. Repeat above procedures until all frequencies measured were complete.

4.5.4 DEVIATION FROM TEST STANDARD

No deviation.

4.5.5 TEST SETUP

Same as 4.3.5

4.5.6 EUT OPERATING CONDITION

The software provided by client enabled the EUT to transmit and receive data at lowest, middle and highest channel frequencies individually.

4.5.7 TEST RESULTS

MODULATION TYPE	FSK	ENVIRONMENTAL CONDITIONS	25deg. C, 65%RH, 991hPa
INPUT POWER	120Vac, 60Hz	TESTED BY	Kevin Chen

CHANNEL	CHANNEL FREQUENCY (MHz)	20dB BANDWIDTH (MHz)
0	2404.35	1.990
16	2441.22	1.970
31	2471.94	2.470

CH 0

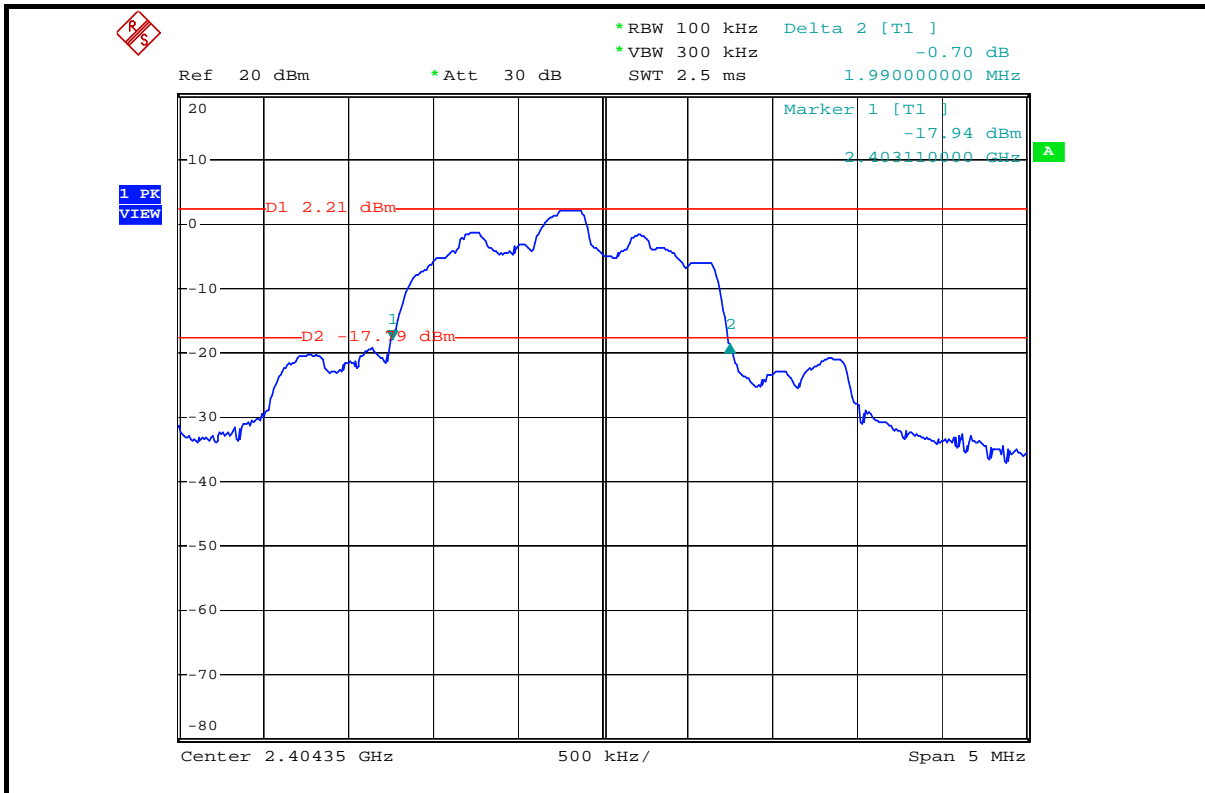

CH 16

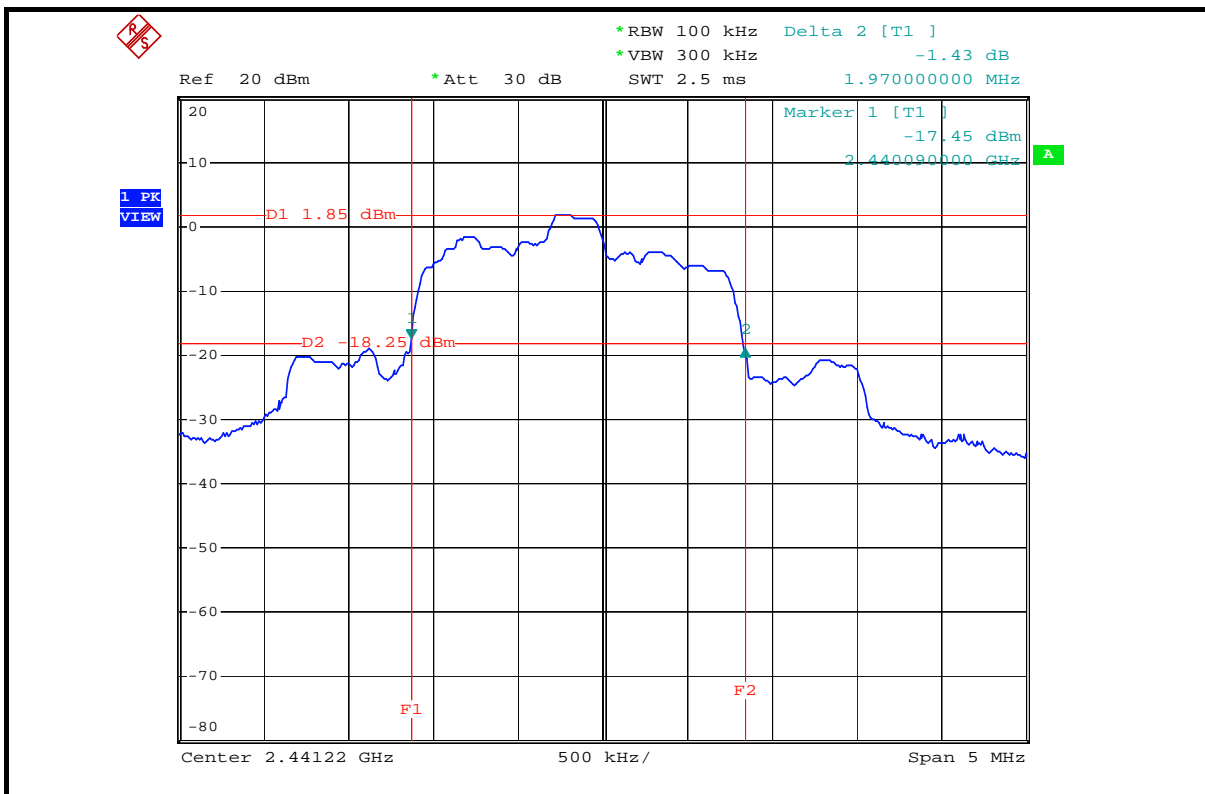

CH 31

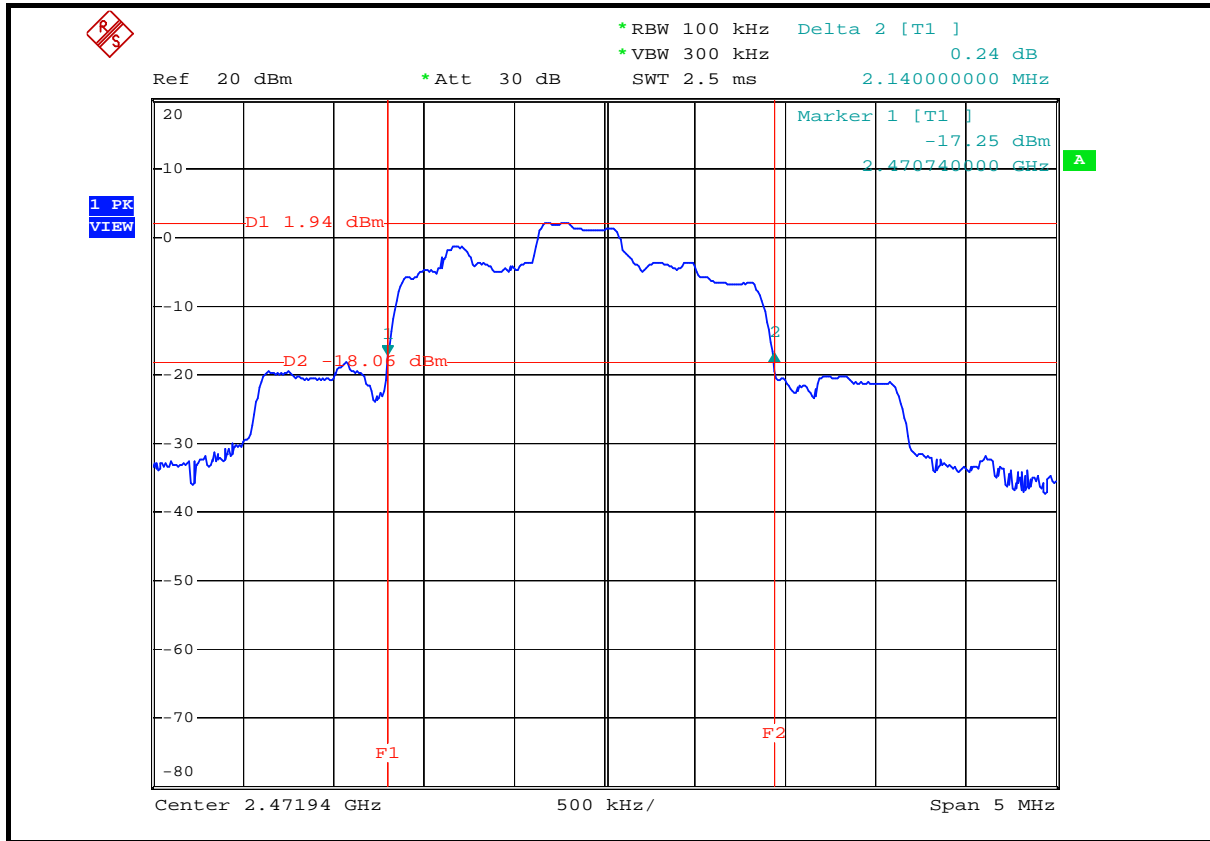



4.6 HOPPING CHANNEL SEPARATION

4.6.1 LIMIT OF HOPPING CHANNEL SEPARATION

At least 25kHz or 20dB hopping channel bandwidth (whichever is greater).

4.6.2 TEST INSTRUMENTS

DESCRIPTION & MANUFACTURER	MODEL NO.	SERIAL NO.	CALIBRATED UNTIL
SPECTRUM ANALYZER	FSP40	100040	Jun. 28, 2008

NOTES: The calibration interval of the above test instruments is 12 months. And the calibrations are traceable to NML/ROC and NIST/USA.

4.6.3 TEST PROCEDURES

- a. Check the calibration of the measuring instrument using either an internal calibrator or a known signal from an external generator.
- b. Turn on the EUT and connect it to measurement instrument. Then set it to any one convenient frequency within its operating range.
- c. By using the MaxHold function record the separation of two adjacent channels.
- d. Measure the frequency difference of these two adjacent channels by SA MARK function. And then plot the result on SA screen.
- e. Repeat above procedures until all frequencies measured were complete.

4.6.4 DEVIATION FROM TEST STANDARD

No deviation.

4.6.5 TEST SETUP

Same as 4.3.5



4.6.6 TEST RESULTS

MODULATION TYPE	FSK	ENVIRONMENTAL CONDITIONS	25deg. C, 65%RH, 991hPa
INPUT POWER	120Vac, 60Hz	TESTED BY	Kevin Chen

CHANNEL	FREQUENCY (MHz)	ADJACENT CHANNEL SEPARATION (MHz)	20dB BANDWIDTH (MHz)	PASS / FAIL
0	2404.35	6.180	1.990	PASS
16	2441.22	6.120	1.970	PASS
31	2471.94	4.140	2.470	PASS

NOTE: The minimum limit is 20dB bandwidth. Test results please refer to next two pages.

CH 0

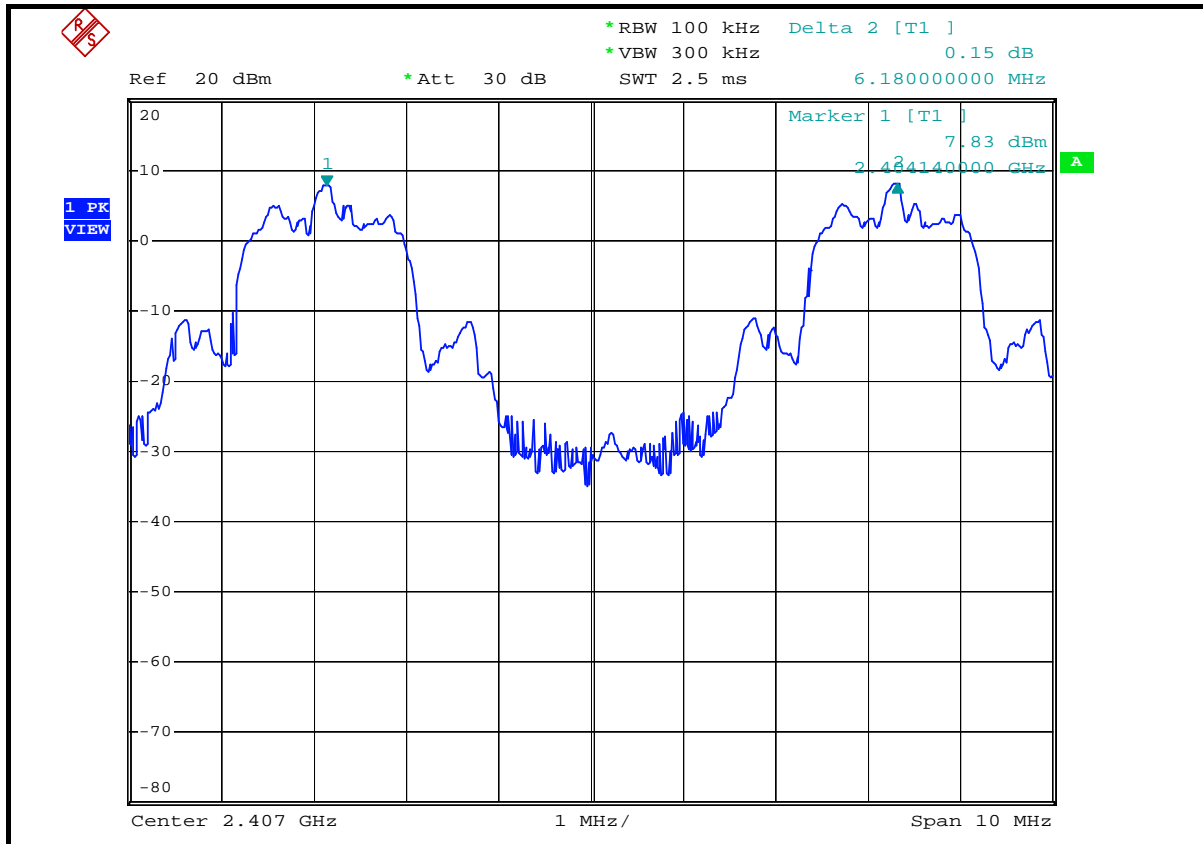

CH 16

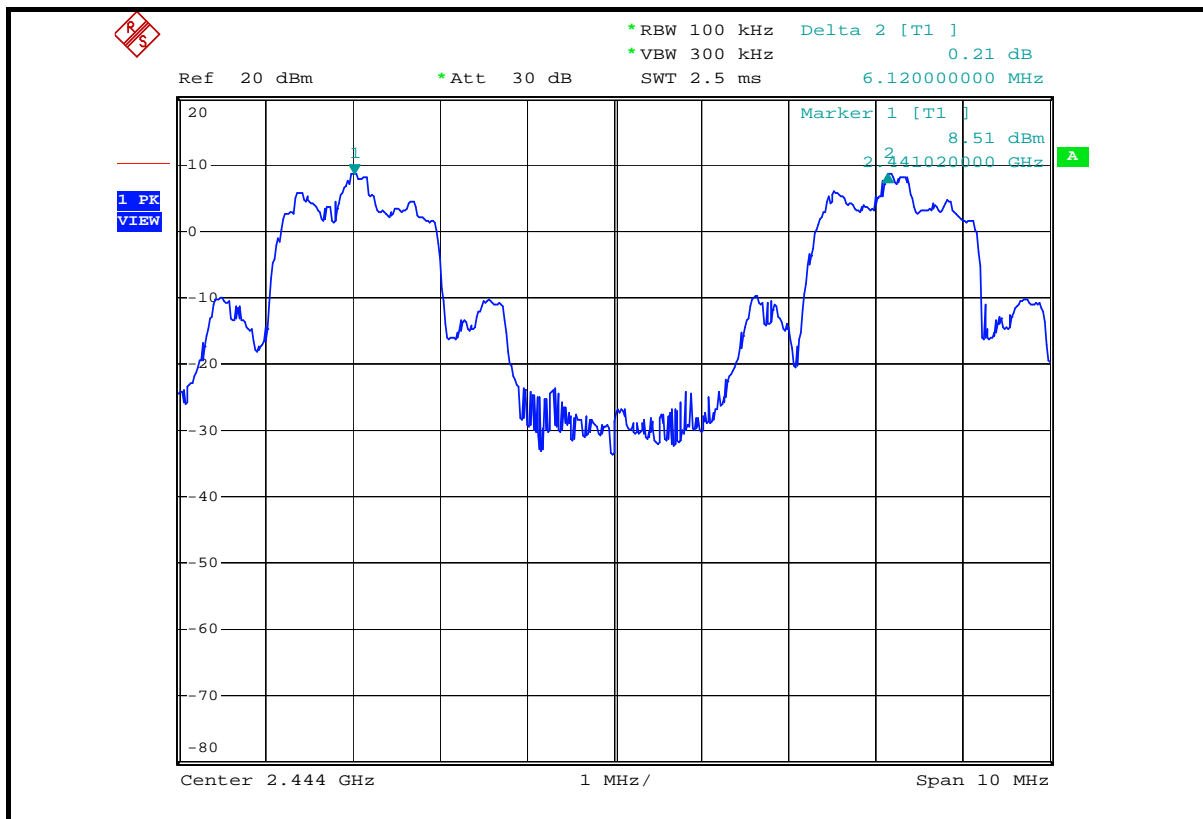

CH 31

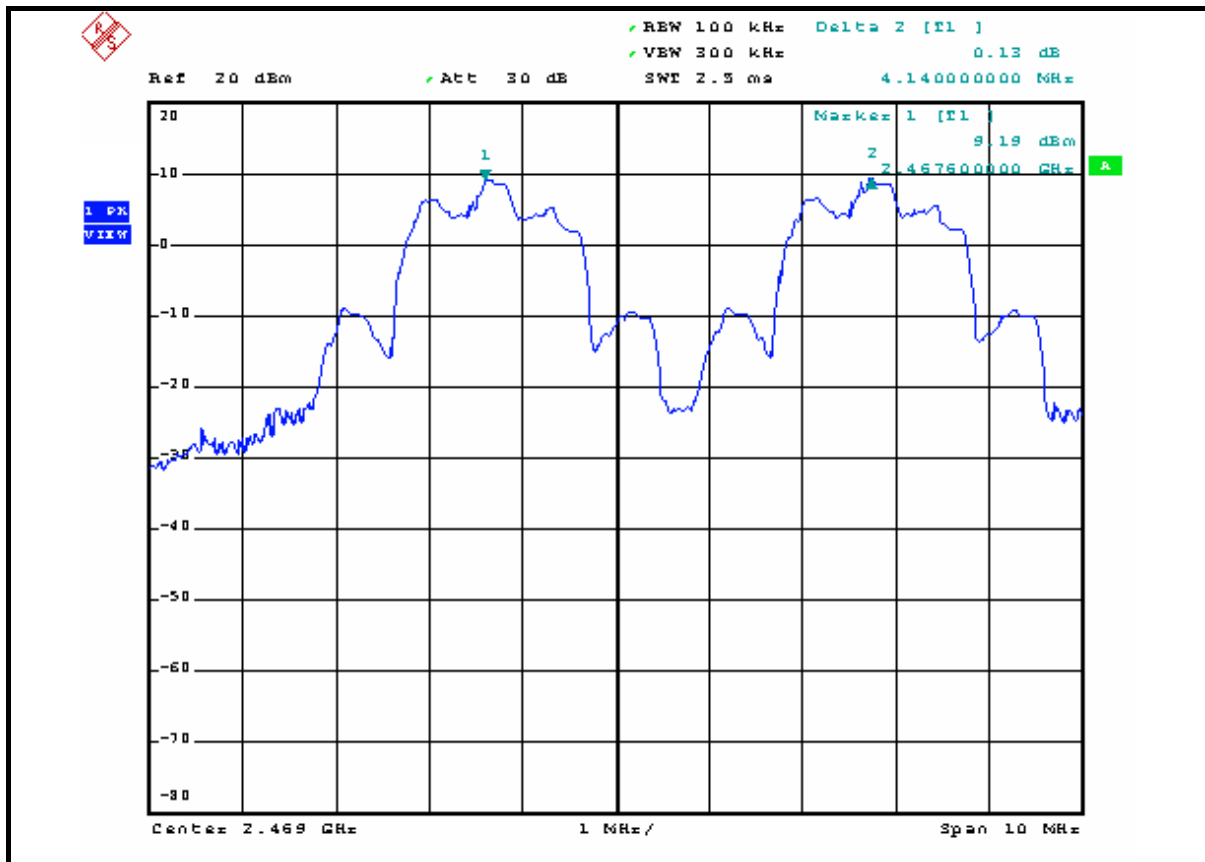



4.7 MAXIMUM PEAK OUTPUT POWER

4.7.1 LIMITS OF MAXIMUM PEAK OUTPUT POWER MEASUREMENT

The Maximum Peak Output Power Measurement is 21dBm.

4.7.2 TEST INSTRUMENTS

DESCRIPTION & MANUFACTURER	MODEL NO.	SERIAL NO.	CALIBRATED UNTIL
SPECTRUM ANALYZER	FSP40	100040	Jun. 28, 2008

NOTE: The calibration interval of the above test instruments is 12 months and the calibrations are traceable to NML/ROC and NIST/USA.

4.7.3 TEST PROCEDURES

- a. Check the calibration of the measuring instrument using either an internal calibrator or a known signal from an external generator.
- b. Turn on the EUT and connect it to measurement instrument. Then set it to any one convenient frequency within its operating range. Set a reference level on the measuring instrument equal to the highest peak value.
- c. The center frequency of the spectrum analyzer is set to the fundamental frequency and using 3MHz RBW and 10 MHz VBW.
- d. Measure the captured power within the band and recording the plot.
- e. Repeat above procedures until all frequencies required were complete.

4.7.4 DEVIATION FROM TEST STANDARD

No deviation



4.7.5 TEST SETUP

Same as 4.3.5

4.7.6 EUT OPERATING CONDITION

The software provided by client enabled the EUT to transmit and receive data at lowest, middle and highest channel frequencies individually.

4.7.7 TEST RESULTS

MODULATION TYPE	FSK	ENVIRONMENTAL CONDITIONS	25deg. C, 65%RH, 991hPa
INPUT POWER	120Vac, 60Hz	TESTED BY	Kevin Chen

CHANNEL	CHANNEL FREQUENCY (MHz)	PEAK POWER OUTPUT (mW)	PEAK POWER OUTPUT (dBm)	PEAK POWER LIMIT (dBm)	PASS/FAIL
0	2404.35	2.265	3.55	21	PASS
16	2441.22	2.109	3.24	21	PASS
31	2471.94	2.234	3.49	21	PASS

CH 78

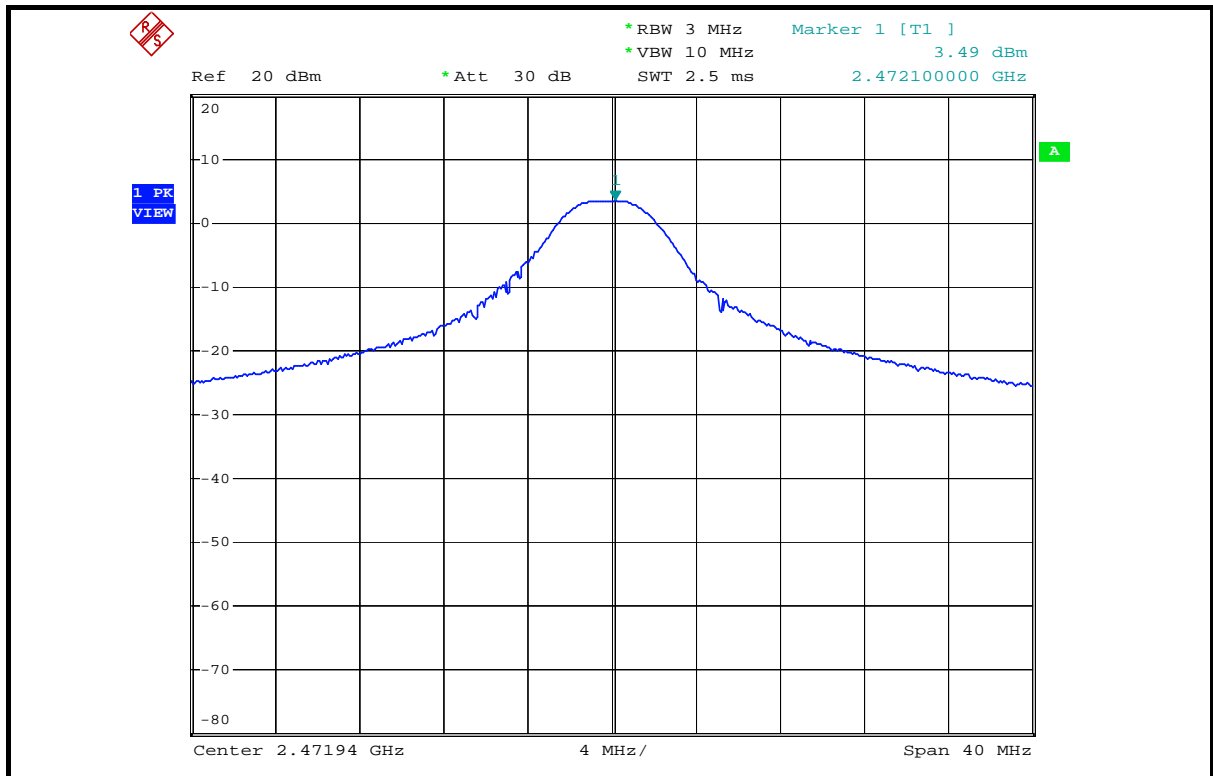

4.8 BAND EDGES MEASUREMENT

4.8.1 LIMITS OF BAND EDGES MEASUREMENT

Below -20dB of the highest emission level of operating band (in 100kHz RBW).

4.8.2 TEST INSTRUMENTS

DESCRIPTION & MANUFACTURER	MODEL NO.	SERIAL NO.	CALIBRATED UNTIL
SPECTRUM ANALYZER	FSP40	100040	Jun. 28, 2008

NOTES: The calibration interval of the above test instruments is 12 months. And the calibrations are traceable to NML/ROC and NIST/USA.

4.8.3 TEST PROCEDURE

The transmitter output was connected to the spectrum analyzer via a low lose cable. Set both RBW and VBW of spectrum analyzer to 100 kHz with suitable frequency span including 100 MHz bandwidth from band edge. The band edges was measured and recorded.

4.8.4 DEVIATION FROM TEST STANDARD

No deviation.

4.8.5 EUT OPERATING CONDITION

The software provided by client enabled the EUT to transmit and receive data at lowest and highest channel frequencies individually.

4.8.6 TEST RESULTS

The spectrum plots are attached on the following 4 images. D1 line indicates the highest level, D2 line indicates the 20dB offset below D1. It shows compliance with the requirement in part 15.247(d).

NOTE 1:

The band edge emission plot on the next page shows 47.65dBc between carrier maximum power and local maximum emission in restrict band (2.33908GHz). The emission of carrier strength list in the test result of channel 0 at the item 4.2.7 is 100.37dBuV/m (Peak), so the maximum field strength in restrict band is $100.37-47.65=52.72$ dBuV/m, which is under 74 dBuV/m limit.

Average value = $52.72-40.00=12.72$ dBuV/m, which is under 54dBuV/m limit.

*The duty cycle correction factor be equal to: $20\log(0.5^2/100)=-40.00$ dB

Average value = peak reading – 40.00

NOTE 2:

The band edge emission plot on the next second page shows 49.19dBc between carrier maximum power and local maximum emission in restrict band (2.48550GHz). The emission of carrier strength list in the test result of channel 16 at the item 4.2.7 is 99.09dBuV/m (Peak), so the maximum field strength in restrict band is $99.09-49.19=49.90$ dBuV/m, which is under 74 dBuV/m limit.

Average value = $49.90-40.00=9.90$ dBuV/m, which is under 54dBuV/m limit.

*The duty cycle correction factor be equal to: $20\log(0.5^2/100)=-40.00$ dB

Average value = peak reading – 40.00

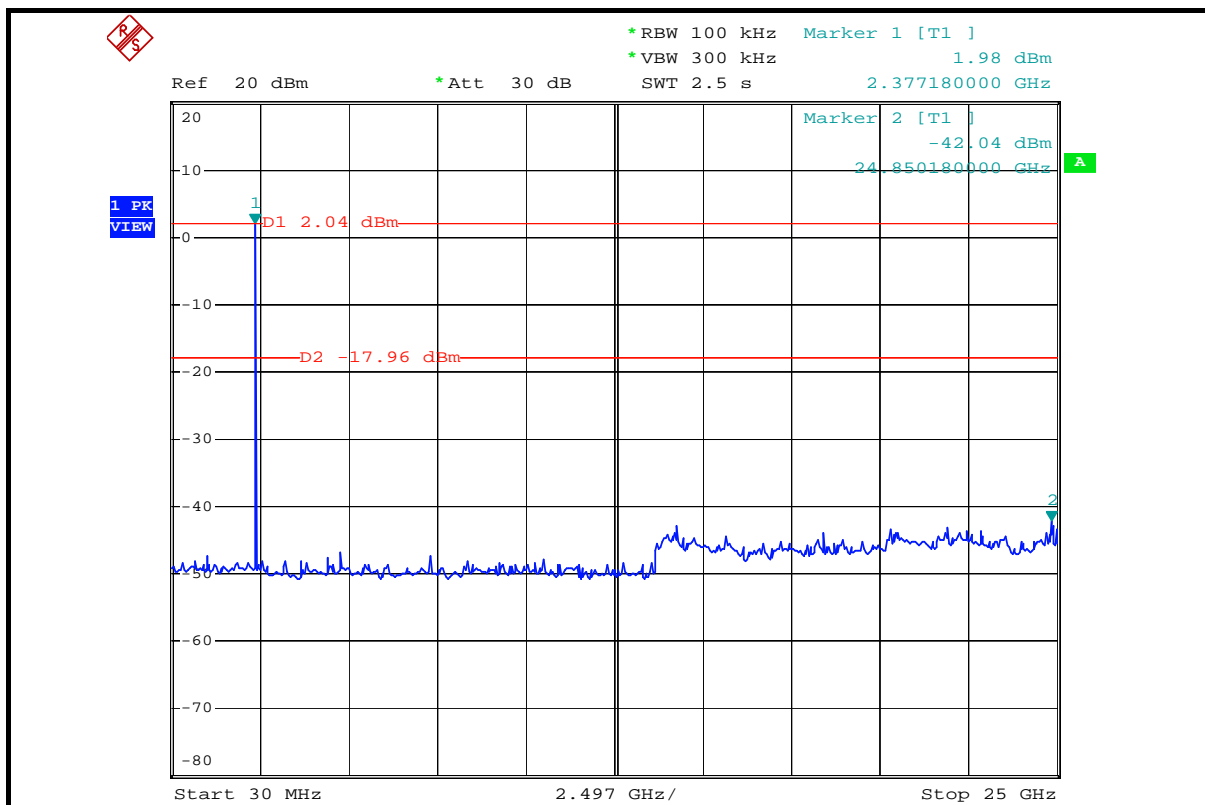
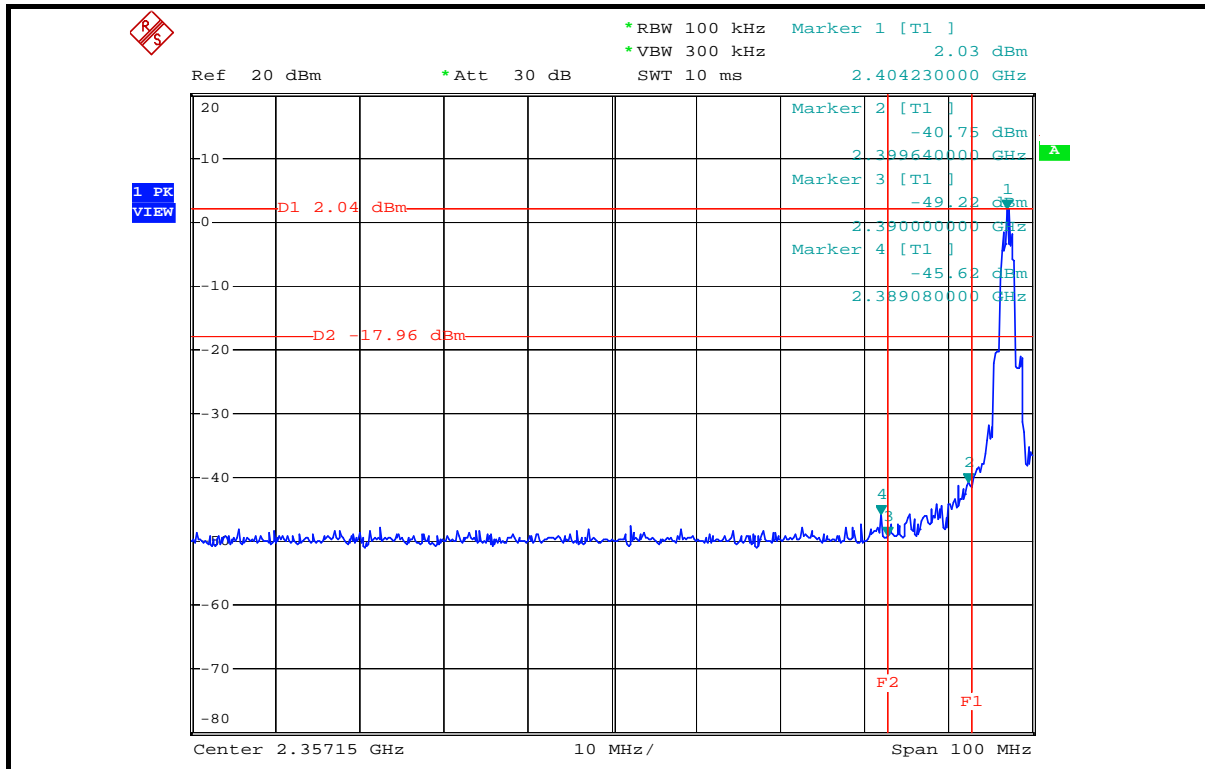

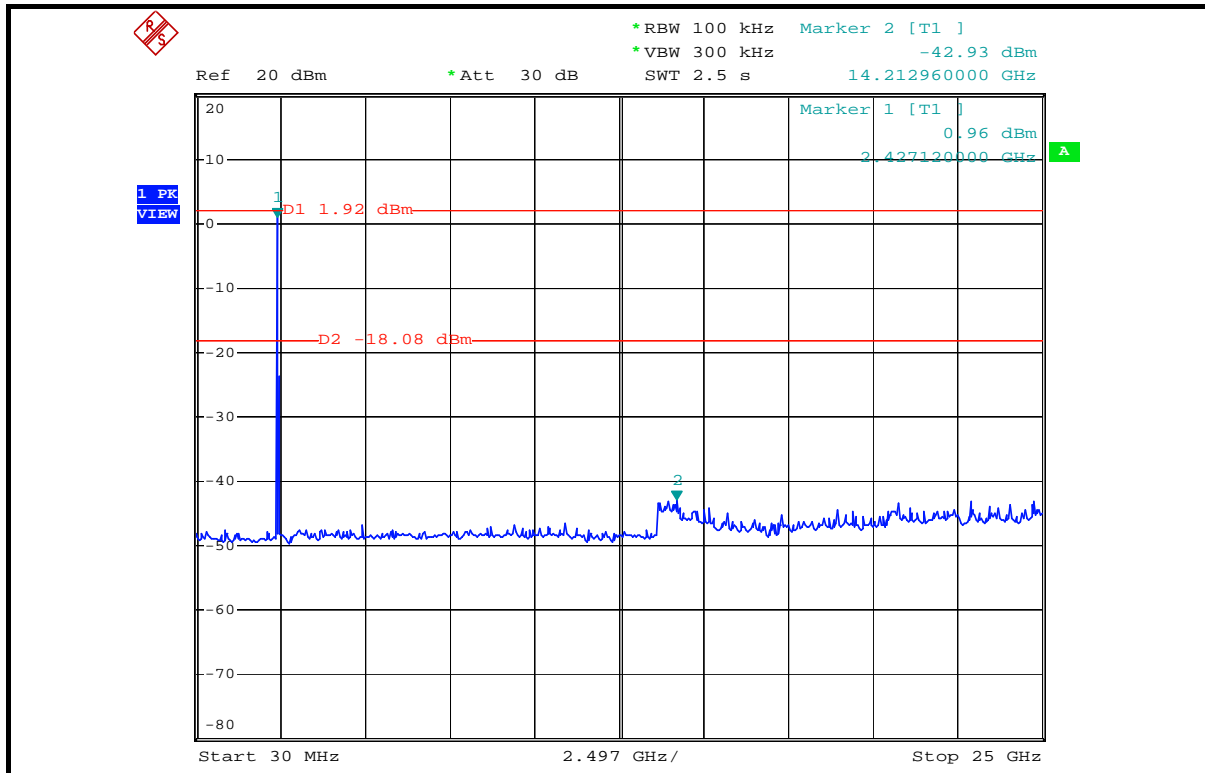
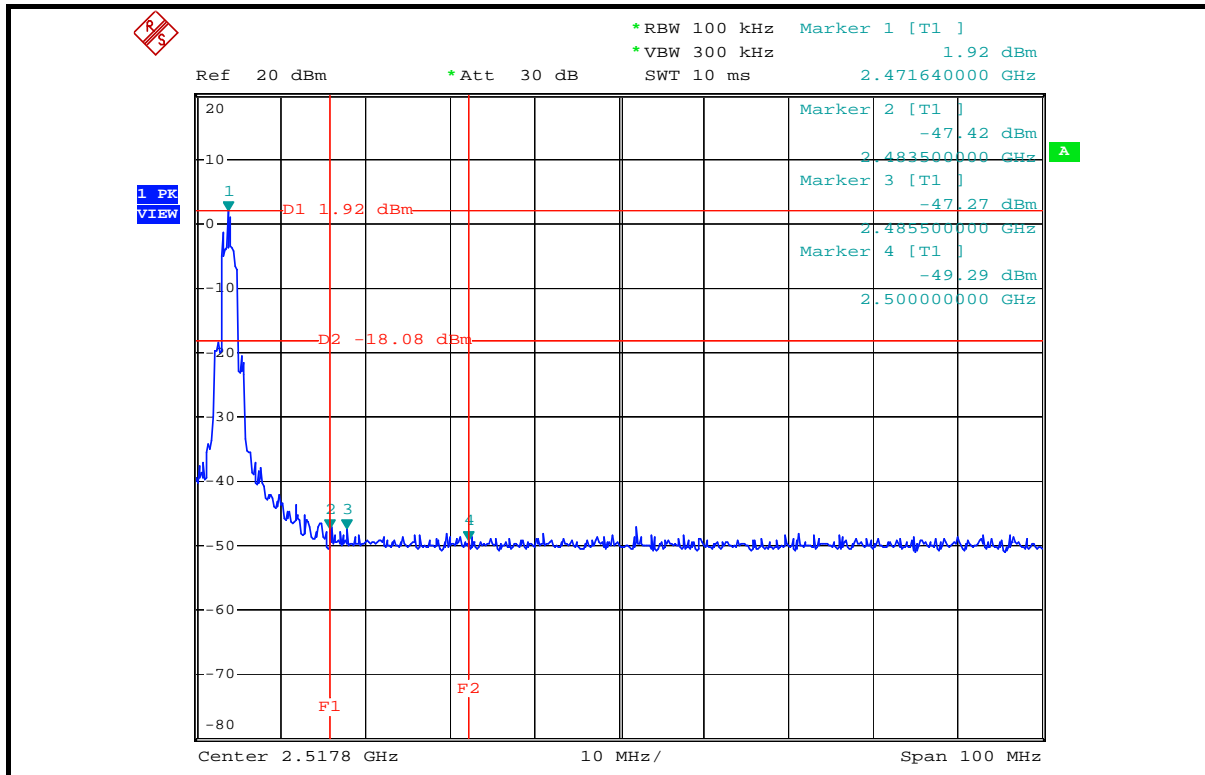

4.9 ANTENNA REQUIREMENT

4.9.1 STANDARD APPLICABLE

For intentional device, according to FCC 47 CFR Section 15.203, an intentional radiator shall be designed to ensure that no antenna other than that furnished by the responsible party shall be used with the device.

And according to FCC 47 CFR Section 15.247 (b), if transmitting antennas of directional gain greater than 6 dBi are used, the power shall be reduced by the amount in dB that the directional gain of the antenna exceeds 6 dBi.

4.9.2 ANTENNA CONNECTED CONSTRUCTION

The antenna used in this product is dipole antenna without antenna connector. The maximum gain of this antenna is 2dBi.



5. PHOTOGRAPHS OF THE TEST CONFIGURATION

Please refer to the attached file (Test Setup Photo).



6. INFORMATION ON THE TESTING LABORATORIES

We, ADT Corp., were founded in 1988 to provide our best service in EMC, Radio, Telecom and Safety consultation. Our laboratories are accredited and approved by the following approval agencies according to ISO/IEC 17025.

USA	FCC, UL, A2LA
Germany	TUV Rheinland
Japan	VCCI
Norway	NEMKO
Canada	INDUSTRY CANADA, CSA
R.O.C.	TAF, BSMI, NCC
Netherlands	Telefication
Singapore	GOST-ASIA(MOU)
Russia	CERTIS(MOU)

Copies of accreditation certificates of our laboratories obtained from approval agencies can be downloaded from our web site:

www.adt.com.tw/index.5/phtml. If you have any comments, please feel free to contact us at the following:

Linko EMC/RF Lab:
Tel: 886-2-26052180
Fax: 886-2-26051924

Hsin Chu EMC/RF Lab:
Tel: 886-3-5935343
Fax: 886-3-5935342

Hwa Ya EMC/RF/Safety Telecom Lab:
Tel: 886-3-3183232
Fax: 886-3-3185050

Web Site: www.adt.com.tw

The address and road map of all our labs can be found in our web site also.

7. APPENDIX A – MODIFICATIONS RECORDERS FOR ENGINEERING CHANGES TO THE EUT BY THE LAB

No any modifications are made to the EUT by the lab during the test.