

Installation and Operating Instruction

Product Layout

Camera (Fig. 1)

- ① Low battery indicator LED
- ② Power indicator LED
- ③ Microphone
- ④ Infrared LEDs
- ⑤ Lens
- ⑥ Keyholes
- ⑦ Battery compartment
- ⑧ 6V DC power adaptor jack
- ⑨ Learn button
- ⑩ Power On/Off switch
- ⑪ Channel selection switch

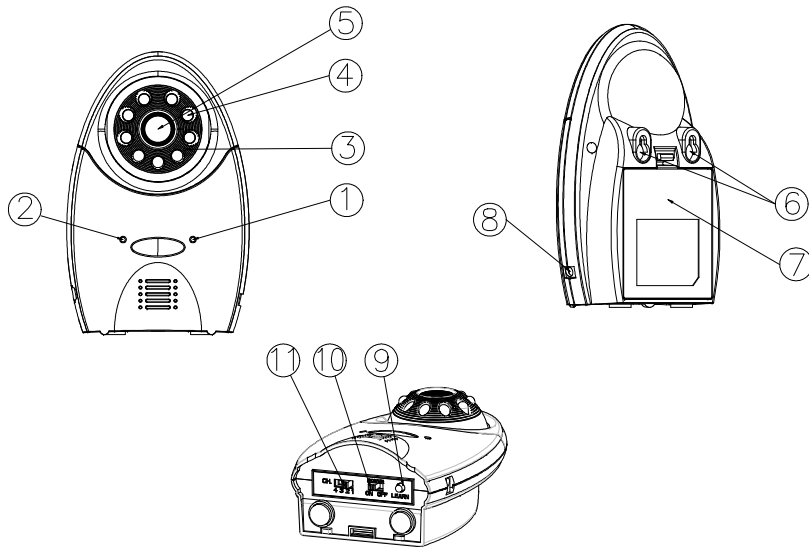

Fig. 1

Monitor (Fig. 2)

- ① Sensitivity level control
- ② Volume/power control
- ③ Brightness/contrast ratio control
- ④ Speaker
- ⑤ LEDs indicator
- ⑥ 6V DC power adaptor jack
- ⑦ Hang up hole
- ⑧ Keyholes
- ⑨ Swiveling pivot

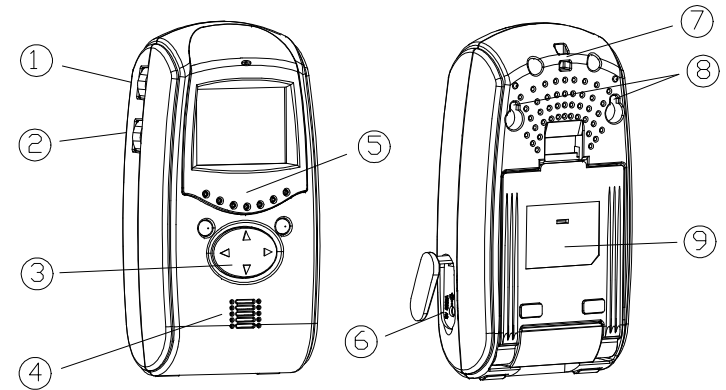

Fig. 2

Kit Content

1 x Camera	4 x 1.5V AA-size Battery (for Monitor)
1 x Monitor	All Fixing Screws
1 x AC/DC Adaptor (for Camera)	This manual

Introduction

This package is designed to facilitate the users who intend constant observation of the particular place where continuous caring or surveillance is needed. Both Camera and Monitor units are suitable for indoor use only.

Either 4 AA-size batteries or an AC/DC adaptor can be used as their power source. When the battery level falls below an unacceptable level, the "LOW BATTERY" indicator on the front of the Camera and Monitor will light up. When this occurs the batteries should be replaced as soon as possible.

Setting Up the Camera

Power Supply

The Camera adopts either 4 AA-size batteries or the AC/DC adaptor (no supplied).

Loading the Batteries

1. Open the battery compartment cover on the rear of the camera. (Fig. 3)
2. Insert 4 AA-size batteries, ensuring that correct polarity is put. (Fig. 3)
3. Refit the battery compartment cover and make sure it is locked securely.

Note: Never mix old batteries with new ones.

Remove the batteries from the Camera if you do not plan to use it for a long period of time.

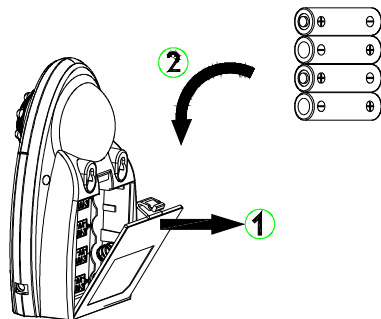

Fig. 3

Using the AC/DC adaptor

Plug one end of the power adaptor into a wall outlet and the other end into the

Camera. The specification of AC/DC adaptor is 6V/500mA with regulator. (Fig. 4)

Note: The AC/DC adaptor shall remain readily operable.

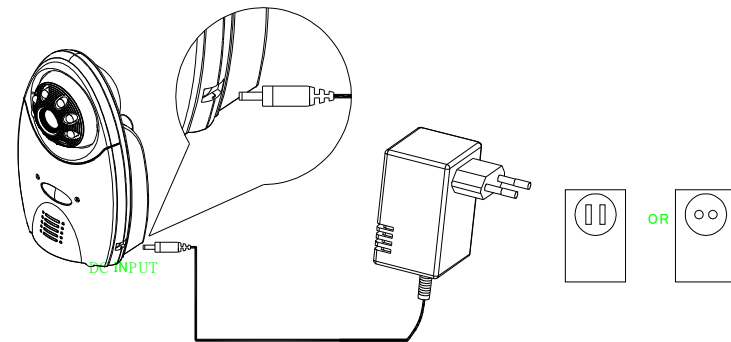

Fig. 4

Installing the Camera

The Camera is suitable for mounting in dry interior locations only. 3 types of installation can be made, such as wall mount, table stand or clip-on the crib.

Place the Camera in a convenient location, point the lens towards the observed area and adjust the angle by adjusting the lens head vertically. (Fig. 5)

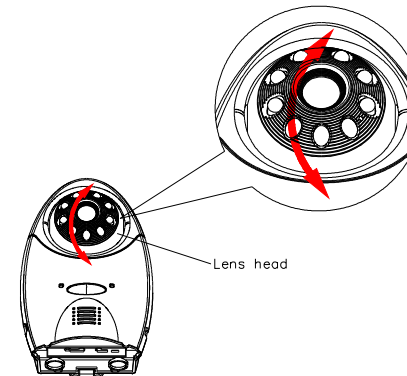

Fig. 5

Wall Mounting the Camera

Note: The Monitor reception should be tested before fixing the camera in place. Ideally you will need someone to hold the Camera against the wall in the selected mounting area while you check the reception on the Monitor. If

interference or other problems occur, refer to the Troubleshooting. You may need to select a different location in the room for mounting the Camera.

1. Decide on the appropriate mounting location. Drill two holes 32mm apart in a line and fit wall plugs. (Fig. 6)
2. Insert fixing screws until almost fully home and hang the Camera over these screws using the two keyhole slots in the rear of the Camera. (Fig. 6)

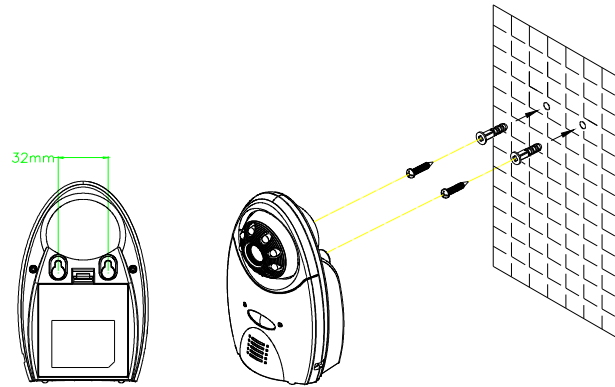

Fig. 6

Clipping on the Camera

1. Use the clip as supplied for fixing the Camera on the crib or table edge. (Fig. 7)
2. Place the clip to the two slots on the top of Camera and lift it up to fit it in place. (Fig. 7)

Note: For removing the clip, push the clip downward. (Fig. 8)

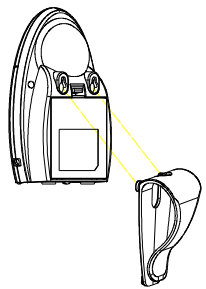

Fig. 7

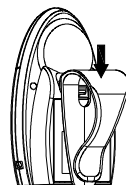
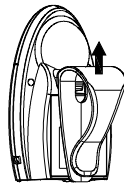

Fig. 8

Operating the Camera

1. The ON/OFF slide switch is for turning on and off the power. (Fig. 9)
2. Up to four cameras can be connected to the Monitor. Set the channel switch (numbered 1~4) that matches to that of the Monitor you plan to observe. (Fig. 9)

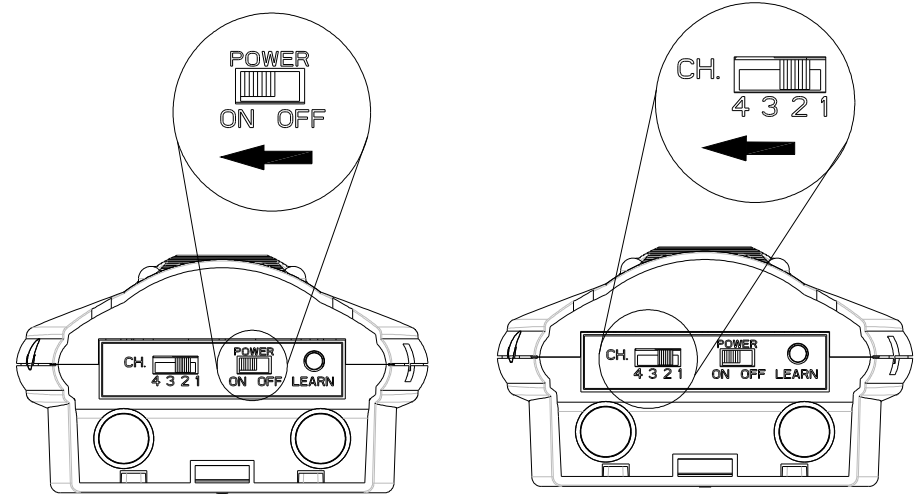

Fig. 9



Note: If more than 2 cameras are in use, do not set the same channel at the same time.

3. Learning the ID code
In order to prevent any unauthorized attempt to operate or disarm your system, you must configure your system to accept radio signals only from your own system devices. All Cameras have their unique ID code, the Monitor must learn their codes individually for the system to operate correctly.

Pressing the learn button will emit the ID code to the Monitor, subject to the Monitor enters ID code learn mode. Refer to page 5 for detailed instruction.

4. Night Vision Mode (Infrared LEDs)

There are 6 auxiliary infrared LEDs adjacent to the camera lens. They are designed to enhance low light level visibility. When the ambient light level is lower than 10 Lux, the infrared LEDs will start operating automatically, while if it is higher than 200 Lux, the infrared LEDs will shut down automatically. Keep a minimum distance of 30cm between infrared LEDs and observed object. Otherwise the camera is liable to make wrong judgement.

5. When the low battery LED  lights up, replace batteries immediately.
6. While turning on the ON/OFF switch, the low battery LED  will be on shortly then extinguish.
7. Under normal operation, the power LED  should be on.

Setting Up the Monitor

Power Supply

The Monitor uses either 4 AA-size batteries or the AC/DC adaptor.

Note: When replacing batteries or connecting to the AC/DC adaptor, turn off the Monitor.

Loading the Batteries

1. Remove the power cavity from the rear of the Monitor. (Fig. 10)

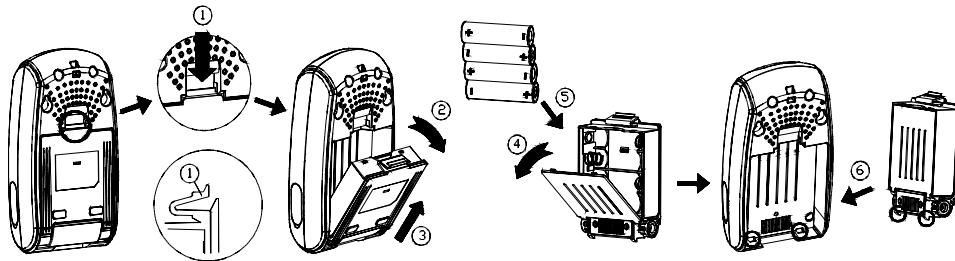

Fig. 10

2. Open the battery compartment cover and fit 4 AA-size batteries, following + and - signs as indicated on the inside battery compartment. (Fig. 10)
3. Close the battery compartment cover and refit the power cavity in place. (Fig. 10)

Using the AC/DC Adaptor

Plug one end of the provided power adaptor into a wall outlet and the other end into the side of Monitor. The specification of AC/DC adaptor is 6V/500mA with regulator. (Fig. 11)

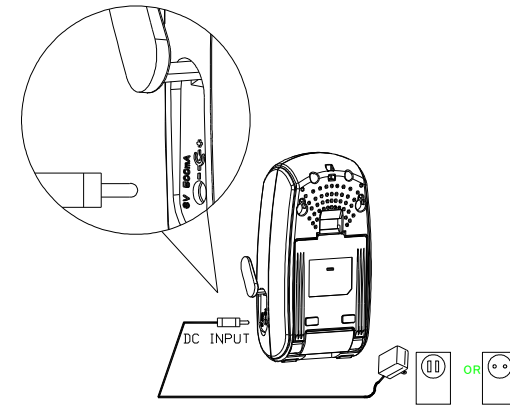

Fig. 11

Note: The AC/DC adaptor shall remain readily operable.

Installing the Monitor

3 types of installation can be made, such as wall mount, free standing and hang up by string.

Wall Mounting the Monitor

1. Decide on the appropriate mounting location. Drill two holes 48mm apart in a line and fit wall plugs. (Fig. 12)
2. Insert fixing screws until almost fully home and hang the Monitor over these screws using the two keyhole slots in the rear of the Monitor. (Fig. 12)

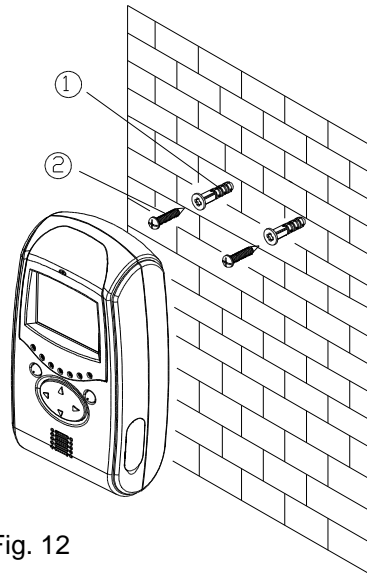
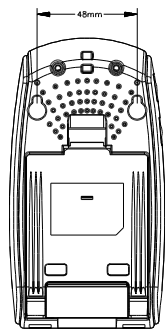

Fig. 12

Free standing the Monitor

The Monitor has the swiveling pivot which allows flexible angle adjustment for free standing installation.

1. Adjust the swiveling pivot to an appropriate angle for best viewing condition. (Fig. 13)

Note: To meet various applications, the angle of swiveling pivot can attain 80° and 50°.

2. Place the Monitor to an ideal location.

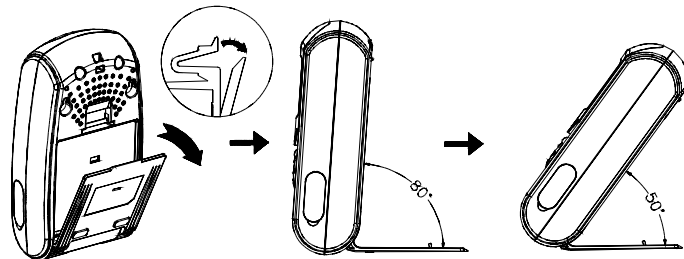

Fig. 13

Hanging up the Monitor

On the top of the rear of Monitor, penetrate a string through the hole.

Operating the Monitor

1. Learning the ID code

In order to prevent any unauthorized attempt to operate or disarm your system, you must configure your system to accept radio signals only from your own system devices. All Cameras have their unique ID code, the Monitor must learn their codes individually for the system to operate correctly.

- a. Set the number of channel switch to different number on each camera. When learning the ID code, ensure that the distance among each Camera cannot be too close so as to avoid interference.
- b. Slide the ON/OFF switch to ON position for all connected Cameras. And turn on the Volume/Power control (Fig. 14) on the Monitor. Ensure that the Monitor is set in Audio/Video mode.
- c. Press the CH selection button (Fig. 15) on the Monitor for a while. Four channel LEDs (numbered 1 to 4) on the Monitor will all light up for a moment simultaneously, which implies that the Monitor enters ID code learn mode.
- d. The LED for each channel will flash in turn once on the Monitor. While the channel 1 LED is flashing, press the learn button of the corresponding Camera, which is set for channel 1, so as to emit the ID code to the Monitor. Follow the same step for the rest of cameras.
- e. If successful, four channel LEDs on the Monitor will all illuminate shortly before the learnt channel LED(s) flashes. If failure, four channel LEDs on the Monitor neither flash nor illuminate.

Note: The preset ID code will be memorized permanently despite the power being disconnected.

2. Cleaning out the ID code

- a. Press the CH selection button on the Monitor for a while. Four channel LEDs (numbered 1 to 4) on the Monitor will all light up for a moment simultaneously, which implies that the Monitor enters ID code learn mode.
- b. Press the CH selection button again. All of the preset ID codes will be cleaned out.

3. Upon reception from the Camera, 4 modes can be selected by pressing

the mode selection button (Fig. 15) on the front of Monitor.

- a. Audio/video mode: The Monitor is on continuously, emitting sound and image. Under this mode, both ϑ and z^{z^z} LEDs will not illuminate. (Fig. 15) No matter what mode it is, simply enter Audio/video mode for impromptu surveillance.
- b. Audio mode: The Monitor only delivers audio and ϑ LED will light up. (Fig. 15)
- c. Audio-activated mode: This audio-activated mode allows you to set the sensitivity of audio level that will trigger the Monitor. To use audio-activated function, follow these steps:
 - c-1: Set the sensitivity control (Fig. 14) on the Monitor to the level you prefer.

Note: The sensitivity level can vary between 0 to 9. A value of 0 gives maximum sensitivity, a value of 9 gives minimum sensitivity.
 - c-2: Press the mode selection button on the front of the Monitor, the z^{z^z} LED lights up.
 - c-3: When the sound from the Camera reaches the set level, the Monitor will turn on automatically. It will turn off automatically after 30 seconds.
- d. Auto scan mode: Press the mode selection button on the front of Monitor until ϑ , z^{z^z} LEDs are on.
 - d-1: Ensure the number of channel switch set for each camera is different. Slide the ON/OFF switch to ON position for each camera.
 - d-2: The Monitor will scan the connection of each enabled camera and make record at the beginning.
 - d-3: The video image of each enabled camera will be shown on the Monitor for approx. 5 seconds and each channel sequence will be rotated repeatedly.

Note: If some of the cameras had not been switched on or had not been scanned by the Monitor before or after the auto scan mode being employed, it is a must to re-enter the auto scan mode by pressing the mode selection button until ϑ , z^{z^z} LEDs are on or

pressing the CH selection button on the Monitor to re-scan.

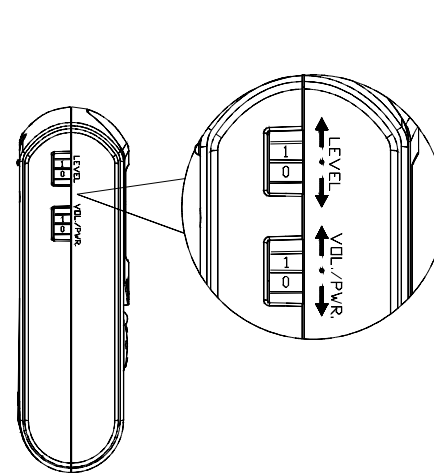

Fig. 14a

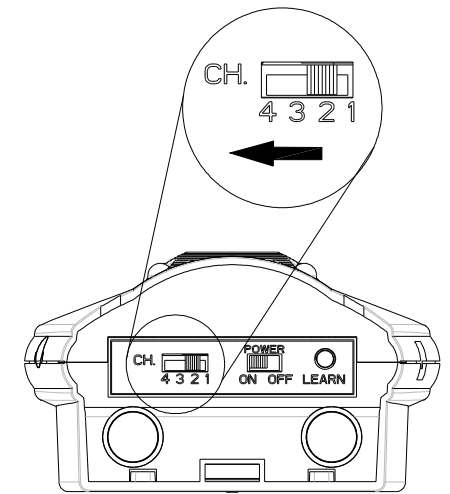

Fig. 14b

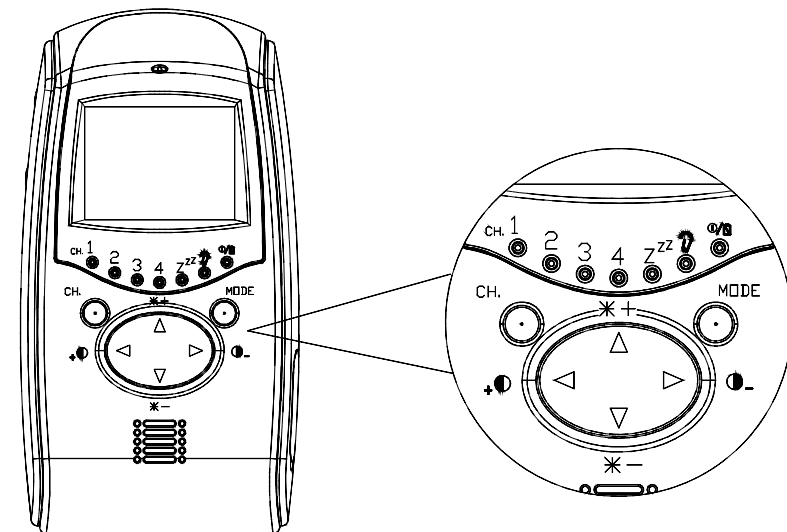

Fig. 15

Judging from the following LED indication may know better what mode it is:

z ^z LED	LED	Mode
Off	off	Audio/video
Off	on	Audio
On	off	Audio-activated
On	on	Auto scan

2. Volume/Power control: It allows you to adjust the audio level received from the Camera. (Fig. 14a)

Note: The audio level can vary between 0 to 9. A value of 0 gives minimum level, a value of 9 gives maximum level.

3. CH selection button: 4 channels are available by pressing CH selection button on the front of the Monitor. (Fig. 15) The channel sequence will be rotated once by pressing the button each time. Set the channel switch (numbered 1~4) on the Camera to the same channel as that of the Monitor. (Fig. 14b)

4. Brightness/Contrast Ratio Control: The brightness and contrast ratio control for the Monitor can be adjusted by pressing the below button: (Fig. 15)

☀ + : Increase brightness

☀ - : Reduce brightness

+⦿ : Increase contrast ratio

⦿- : Reduce contrast ratio

5. When the battery level drops, the ⦿/🔋 LED will be in red. Battery replacement should be taken as soon as possible. If everything is ok, the ⦿/🔋 LED will be in green.

6. If more than one Camera are in use, avoid selecting the adjacent channel, it would be of great help to maintain good visual quality. For instance, when using 2 pcs of Cameras, choose CH1 \ CH3, or CH2 \ CH4 or CH1 \ CH4.

Care and Maintenance

- Keep all parts and accessories out of young children's reach.
- Fingerprints or dirt on the lens surface can adversely affect camera performances. Avoid touching the lens surface with your fingers.
- Should the lens become dirty, use a blower to blow off dirt and dust, or a soft, dry cloth to wipe off the lens.
- Keep the camera dry. Precipitation, humidity, and other liquids contain minerals that will corrode electronic circuits.
- Do not use or store in dusty, dirty areas.
- Do not store in hot areas. High temperatures can shorten the life of electronic devices and warp or melt certain plastics.
- Do not store in very cold areas. When the system warms up (to its normal temperature), moisture can form inside the case, which may damage electronic circuit boards.
- Do not attempt to open the case. Non-expert handling of the device may damage the system.
- The system shall not be exposed to dripping or splashing and that no objects filled with liquids, such as vases, shall be placed on the system.
- Avoid dropping or strong shocks.
- Do not overload electrical outlets or extension cords this can result in fire or electric shocks.
- Do remember that you are using public airwaves when you use the system and that sound and video may be broadcast to other 2.4GHz receiving devices. Conversations, even from rooms near the camera, may be broadcast. To protect the privacy of your home, always turn the camera off when not in use.

Troubleshooting

Status	Possible Cause	Remedy
Power indicator LED does not light up	a. Reverse polarity b. Run out of battery c. AC/DC adaptor is out of order	a. Follow the polarity shown inside the battery compartment for loading the batteries b. Replace new 4 AA-size batteries

		c. Replace a new adaptor
Monitor learnt the ID code successfully, but Monitor screen reveals "no signal"	When learning the ID code from the Camera, interference by RF has occurred	Set the On/Off slide switch of Camera to off, then turn it back on
"No signal" is shown on the Monitor	<p>a. Interference by bluetooth or radio frequency or too far distance between Camera and Monitor</p> <p>b. Same channel has been set between Cameras</p> <p>c. Camera and Monitor do not set the same channel</p> <p>d. Does not proceed with learning the ID code</p>	<p>a. Reposition the Camera or Monitor</p> <p>b. Set different channel on each Camera</p> <p>c. Check that the channel switches on the Camera and Monitor are set to the same number</p> <p>d. Learn the ID code again</p>

Specifications

Camera		Monitor	
Frequency	2.4GHz	Frequency	2.4GHz
Channel	4 selectable channels	Channel	4 selectable channels
A/V mod/demod. method	GFSK	A/V mod/demod. method	GFSK
Antenna	Built-in omni-directional antenna	Antenna	Built-in omni-directional antenna
Image Sensor	1/4" CMOS	Display	2" or 1,5" TFT LCD
Lens	f 6.0mm, F2.0	Display colors	Full-color
Pixel	320 x 240	Pixel	480 x 240 or 320 x 220
Lux level for Auto illumination	Below 10 lux	Power	AC/DC adaptor with regulator

Power	AC/DC adaptor with regulator 120V/60Hz 6V/500mA 230V/50Hz 6V/500mA Battery: 4 AA-size batteries	120V/60Hz 6V/500mA 230V/50Hz 6V/500mA Battery: 4 AA-size batteries
Operating Temperature	0°C~40°C (32°F~104°F)	Operating Temperature 0°C~40°C (32°F~104°F)
Operating humidity range	85% RH	Operating humidity range 85% RH
Application	For indoor use only	Application For indoor use only
Operating Range	100 meters in open space	Weight 210g
Weight	150g	Dimensions 140 x 75 x 42mm
Dimensions	129.5 x 83.5 x 77.5mm	

Specifications are subject to change without prior notice. A501110885R



Mobile of end product Federal Communication Commission Interference Statement

This equipment has been tested and found to comply with the limits for a Class B digital device, pursuant to Part 15 of the FCC Rules. These limits are designed to provide reasonable protection against harmful interference in a residential installation. This equipment generates, uses and can radiate radio frequency energy and, if not installed and used in accordance with the instructions, may cause harmful interference to radio communications. However, there is no guarantee that interference will not occur in a particular installation. If this equipment does cause

harmful interference to radio or television reception, which can be determined by turning the equipment off and on, the user is encouraged to try to correct the interference by one of the following measures:

- Reorient or relocate the receiving antenna.
- Increase the separation between the equipment and receiver.
- Connect the equipment into an outlet on a circuit different from that to which the receiver is connected.
- Consult the dealer or an experienced radio/TV technician for help.

This device complies with Part 15 of the FCC Rules. Operation is subject to the following two conditions: (1) This device may not cause harmful interference, and (2) this device must accept any interference received, including interference that may cause undesired operation.

FCC Caution: Any changes or modifications not expressly approved by the party responsible for compliance could void the user's authority to operate this equipment.

IMPORTANT NOTE:

FCC Radiation Exposure Statement:

This equipment complies with FCC radiation exposure limits set forth for an uncontrolled environment.

To maintain compliance with FCC RF exposure compliance requirements, please avoid direct contact to the transmitting antenna during transmitting. This equipment should be installed and operated with minimum distance 20cm between the radiator & your body.

This transmitter must not be co-located or operating in conjunction with any other antenna or transmitter.