



**Spectrum Research & Testing Lab., Inc.**  
No. 101-10, Ling 8,  
Shan-Tong Li, Chung-Li  
City, Taoyuan, Taiwan

## TEST REPORT

Reference No.: A11072604  
Report No.: FCCA11072604  
FCC ID : FSUGMZJR  
Page: 1 of 35  
Date: Aug.18, 2011

Product Name: Traveler 7000  
Model No.: GM-100019/C  
Applicant: KYE SYSTEMS CORP.  
No. 492, Sec. 5, Chung Hsin Rd., San Chung,  
New Taipei City, 24160, Taiwan, R.O.C.  
Date of Receipt: Jul. 26, 2011  
Finished date of Test: Aug. 18, 2011  
Applicable Standards: 47 CFR Part 15, Subpart C  
47 CFR Part 15, Subpart B  
ANSI C63.4: 2003

We, **Spectrum Research & Testing Laboratory Inc (FCC Registered Test Site Number : 170717)**., hereby certify that one sample of the above was tested in our laboratory with positive results according to the above-mentioned standards. The records in the report are an accurate account of the results. Details of the results are given in the subsequent pages of this report.

Tested By :

Jeff Lo

(Jeff Lo)

Date: 2011.08.18

Approved By :

Johnson Ho  
( Johnson Ho, Director )

Date: 8/18/2011



## Table of Contents

1.	DOCUMENT POLICY AND TEST STATEMENT .....	3
1.1	DOCUMENT POLICY .....	3
1.2	TEST STATEMENT .....	3
1.3	EUT MODIFICATION.....	3
2.	DESCRIPTION OF EUT AND TEST MODE .....	4
2.1	GENERAL DESCRIPTION OF EUT .....	4
2.2	USED CHANNEL AND FREQUENCY TABLE.....	4
2.3	DESCRIPTION OF EUT INTERNAL DEVICE .....	5
2.4	EUT OPERATING CONDITION.....	5
2.5	DESCRIPTION OF TEST MODE.....	6
2.6	DESCRIPTION OF SUPPORT UNIT.....	6
3.	DESCRIPTION OF APPLIED STANDARDS.....	7
3.1	SUMMARY OF TEST RESULTS.....	7
4.	TECHNICAL CHARACTERISTICS TEST .....	8
4.1	BANDEDGE TEST .....	8
4.1.1	LIMIT .....	8
4.1.2	TEST EQUIPMENT .....	8
4.1.3	TEST SETUP .....	9
4.1.4	TEST PROCEDURE.....	9
4.1.5	TEST RESULT .....	10
4.2	RADIATED EMISSION TEST .....	15
4.2.1	LIMIT .....	15
4.2.2	TEST EQUIPMENT .....	16
4.2.3	TEST SET-UP.....	17
4.2.4	TEST PROCEDURE.....	18
4.2.5	TEST RESULT.....	19
5.	ANTENNA APPLICATION.....	32
5.1	ANTENNA REQUIREMENT .....	32
5.2	RESULT .....	32
6.	PHOTOS OF TESTING .....	33
7.	TERMS OF ABBREVIATION .....	35



**Spectrum Research &  
Testing Lab., Inc.**  
No. 101-10, Ling 8,  
Shan-Tong Li, Chung-Li  
City, Taoyuan, Taiwan

## **TEST REPORT**

Reference No.: A11072604  
Report No.: FCCA11072604  
FCC ID : FSUGMZJR  
Page: 3 of 35  
Date: Aug.18, 2011

### **1. DOCUMENT POLICY AND TEST STATEMENT**

#### **1.1 DOCUMENT POLICY**

- The report shall not be reproduced except in full, without the written approval of SRT Lab, Inc.

#### **1.2 TEST STATEMENT**

- The test results in the report apply only to the unit tested by SRT Lab.
- There was no deviation from the requirements of test standards during the test.
- DC power source, 1.5Vdc (TX) and AC power source, 120 VAC/60 Hz (RX, from USB port), was used during the test.

#### **1.3 EUT MODIFICATION**

- No modification in SRT Lab.



## 2. DESCRIPTION OF EUT AND TEST MODE

### 2.1 GENERAL DESCRIPTION OF EUT

<b>PRODUCT</b>	Traveler 7000
<b>MODEL NO.</b>	GM-100019/C
<b>POWER SUPPLY</b>	DC power source from battery : 1.5Vdc
<b>CABLE</b>	NA
<b>FREQUENCY BAND</b>	2.400GHz ~ 2.4835GHz
<b>CARRIER FREQUENCY</b>	2.402GHz ~ 2.480GHz
<b>NUMBER OF CHANNEL</b>	20
<b>RATED RF OUTPUT POWER</b>	84.4 dBuV/m
<b>MODULATION TYPE</b>	GFSK
<b>MODE OF OPERATION</b>	Simplex
<b>ANTENNA TYPE</b>	PCB Printed
<b>ANTENNA GAIN</b>	-3 dBi
<b>OPERATING TEMPERATURE RANGE</b>	-20 ~ 50°C

#### NOTE :

For more detailed information, please refer to the EUT's specification or user's manual provided by manufacturer.

### 2.2 Used Channel and Frequency Table

Channel	Frequency	Channel	Frequency
CH01	2402	CH11	2448
CH02	2405	CH12	2451
CH03	2408	CH13	2454
CH04	2411	CH14	2457
CH05	2418	CH15	2462
CH06	2422	CH16	2466
CH07	2425	CH17	2471
CH08	2428	CH18	2474
CH09	2431	CH19	2477
CH10	2434	CH20	2480



**Spectrum Research & Testing Lab., Inc.**  
No. 101-10, Ling 8,  
Shan-Tong Li, Chung-Li  
City, Taoyuan, Taiwan

## TEST REPORT

Reference No.: A11072604  
Report No.: FCCA11072604  
FCC ID : FSUGMZJR  
Page: 5 of 35  
Date: Aug.18, 2011

### 2.3 DESCRIPTION OF EUT INTERNAL DEVICE

DEVICE	BRAND / MAKER	MODEL #	FCC ID / DOC	REMARK
NA				

### 2.4 EUT OPERATING CONDITION

1. Setup the EUT and all peripheral devices .
2. Turn on the power of all equipment and EUT.
3. Set the EUT under continuous transmission condition, standby and link mode.
4. The EUT was set to the highest available power level.



## 2.5 DESCRIPTION OF TEST MODE

Mode			
1	TX	TX	2402 MHz
2			2448 MHz
3			2480 MHz
4		Standby	NA
5	RX	Link	NA

**Note:** The axis X,Y and Z we evaluate in chamber, the X axis is worst case.

X axis:



Y axis:



Z axis:



## 2.6 DESCRIPTION OF SUPPORT UNIT

The EUT was configured by the requirement of ANSI C63.4:2003. All interface ports were connected to the appropriate support units via specific cables. The support units and cables are listed below.

NO	DEVICE	BRAND	MODEL #	FCC ID/DOC	CABLE
1	PC	ACER	Aspire SA85	DoC	1.5m unshielded power cable
2	CRT Monitor	SAMSUNG	PG17IS	DOC	1.8m unshielded power cord 1.5m shielded data cable. With one core.
3	Keyboard	ACER	6311-AT	DoC	1.8m shielded data cable
4	Mouse	IBM	MU29J	DoC	1.5m shielded data cable.
5	Modem	ACEEX	DM-1414	DOC	1.5m unshielded power cord 1.5m shielded data cable.
6	Printer	EPSON	STYLUS C20SX	N/A	1.5m unshielded power cord 1.2m shielded data cable.
7	USB dongle	Genius	N/A	VOC	N/A

**NOTE :** For the actual test configuration, please refer to the photos of testing.



### 3. DESCRIPTION OF APPLIED STANDARDS

The EUT is a wireless product. According to the specifications provided by the applicant, it must comply with the requirements of the following standards:

47 CFR Part 15, Subpart C

47 CFR Part 15, Subpart B

ANSI C63.4: 2003

All tests have been performed and recorded as the above standards.

#### 3.1 SUMMARY OF TEST RESULTS

The EUT has been tested according to the following specifications:

STANDARD SECTION	TEST TYPE AND LIMIT RESULTS	RESULTS
15.203	Antenna requirement Limit : max. 6dBi	PASS
15.247(d)	Band Edge Measurement Limit: 20dB less than the peak value of fundamental frequency (Reference Only)	PASS
15.249	Transmitter Radiated Emissions Limit: Table 15.209	PASS



## 4. TECHNICAL CHARACTERISTICS TEST

### 4.1 Bandedge TEST

#### 4.1.1 LIMIT

FCC Part15, Subpart C Section 15.247. In any 100 kHz bandwidth outside the frequency band in which the spread spectrum intentional radiator is operating, the radio frequency power that is produced by the intentional radiator shall be at least 20 dB below that in the 100 kHz bandwidth within the band that contains the highest level of the desired power, based on either an RF conducted or a radiated measurement. Attenuation below the general limits specified in Section 15.209(a) is not required. In addition, radiated emissions which fall in the restricted bands, as defined in Section 15.205(a), must also comply with the radiated emission limits specified in Section 15.209(a) (see Section 15.205(c)).

OPERATING FREQUENCY RANGE (MHz)	SPURIOUS EMISSION FREQUENCY (MHz)	LIMIT	
		Peak power ration to emission(dBc)	Emission level(dBuV/m)
902 - 928	<902	>20	NA
	>928	>20	NA
	960-1240	NA	54
2400 - 2483.5	<2400	>20	NA
	>2483.5-2500	NA	54
5725 - 5850	<5350-5460	NA	54
	<5725	>20	NA
	>5850	>20	NA

#### 4.1.2 TEST EQUIPMENT

EQUIPMENT/FACILITIES	SPECIFICATIONS	MANUFACTURER	MODEL#/SERIAL#	DUE DATE OF CAL. & CAL. CENTER
SPECTRUM	9K-40GHz	R&S	FSP40/ 100093	DEC. 2011 ETC
PRE-AMPLIFIER	1 GHz TO 26.5 GHz	HP	8449B/ 3008A01995	Nov. 2011 ETC
HORN ANTENNA	1 GHz TO 18 GHz	EMCO	3115/ 6881	Nov. 2011 ETC
K-TYPE CABLE	15M	HUBER SUHNER	SF 102-40/2*11/ 23932/2	Feb. 2012 ETC
K-TYPE CABLE	1M	HUBER SUHNER	SF 102-40/2*11/ 23934/2	May. 2012 ETC

**NOTE:** The calibration interval of the above test equipment is one year and the calibrations are traceable to NML/ROC and NIST/USA.





## 4.1.3 TEST SETUP

### Above 1GHz

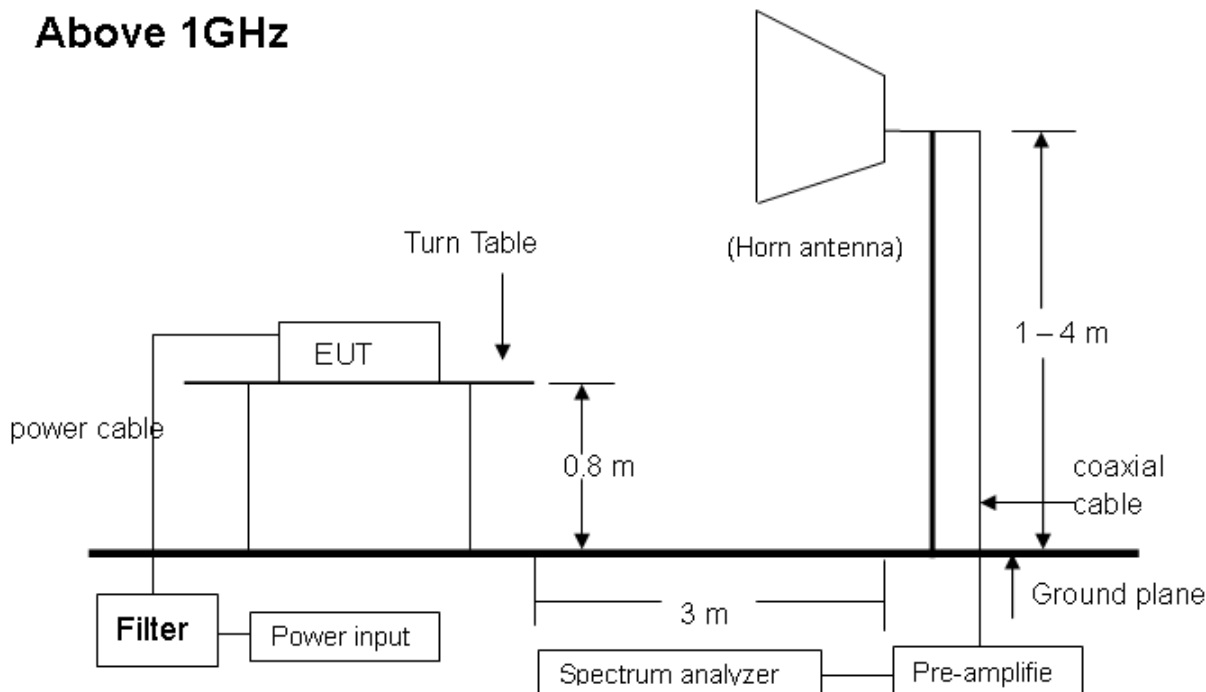

#### NOTE :

1. The EUT system was put on a wooden table with 0.8m heights above a ground plane. For the actual test configuration, please refer to the photos of testing.

## 4.1.4 TEST PROCEDURE

1. The EUT was operating in continuous transmission mode or could be controlled its channel. Printed out the test result from the spectrum by hard copy function.
2. The EUT was tested according to the requirement of ANSI C63.4 and CISPR 22. The measurements were made at an open area test site with 3 meter measurement distance under 1 GHz and with 3m distance above 1GHz. The frequency spectrum measured started from 30 MHz. Under 1 GHz. All readings were quasi-peak values with 120 kHz resolution bandwidth of the test receiver. Above 1 GHz, the measurements were made at an open area test site with 3 meter measurement distance and all readings were peak and average values with 1 MHz resolution bandwidth of the test receiver. The EUT system was operated in all typical methods by users. The cables connected to EUT and support units were moved to find the maximum emission levels for each frequency.



## 4.1.5 TEST RESULT

Temperature:	25°C	Humidity:	61%RH
Spectrum Detector:	PK. and AV.	Tested Mode:	TX
Modulation Type:	GFSK	Tested By:	Jeff Lo
Rediated emission test:		Tested Date:	Aug. 15, 2011

### 1. Conducted test

Frequency (MHz)	PEAK POWER OUTPUT (dBm)	Emission read Value(dBm)	Result of Band edge (dBc)	Band edge LIMIT (dBc)
<2400	-30.49	-66.31	35.82	>20dBc
>2483.5	-23.18	-69.90	46.72	>20dBc

Below 2400MHz :

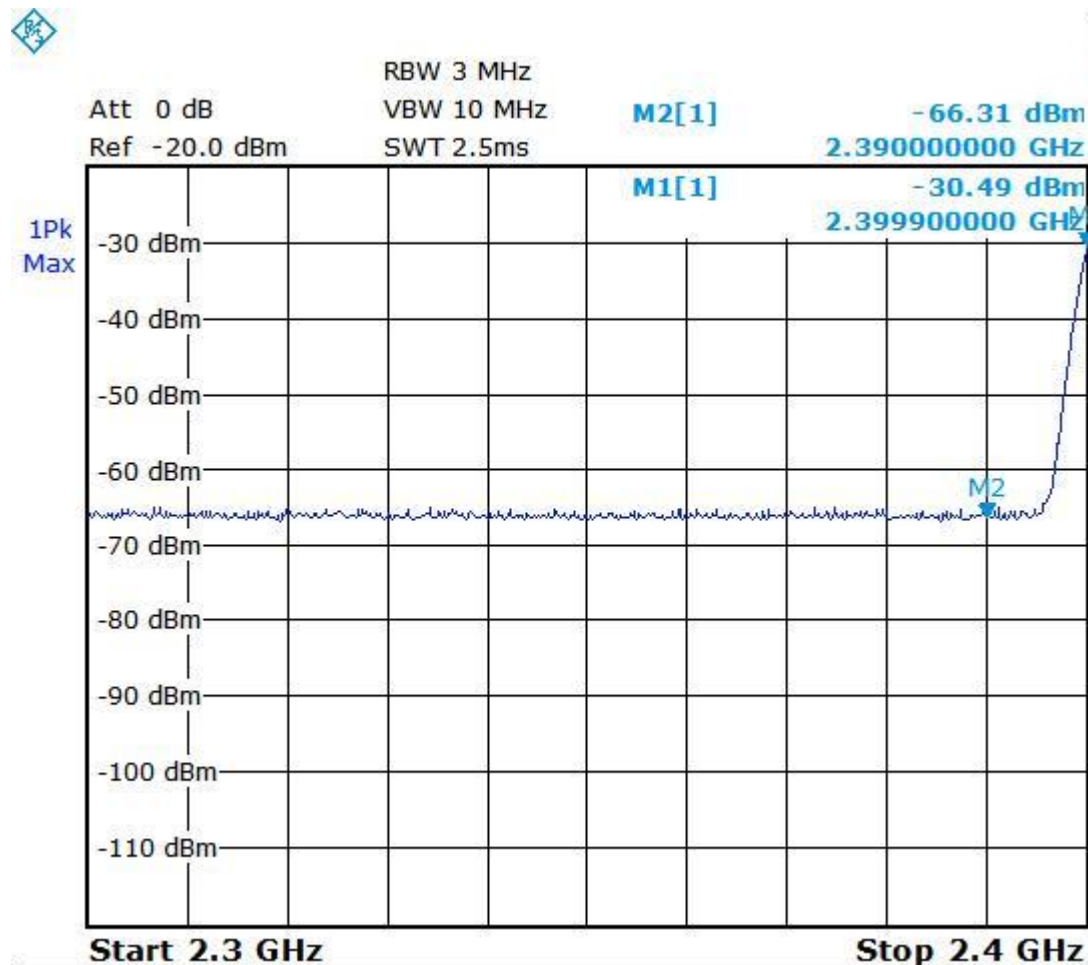



Above 2483.5 MHz :

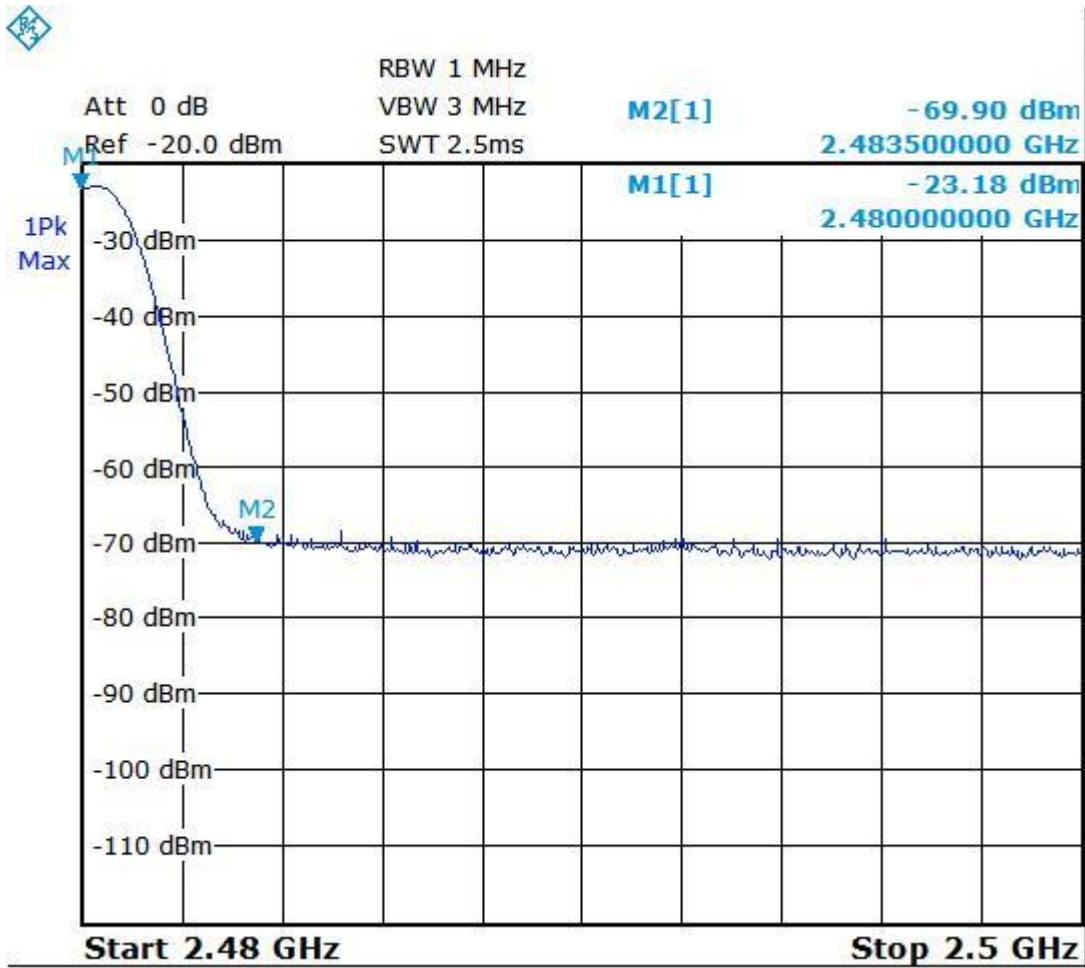



# TEST REPORT

## 2. Radiated emission test:

Frequency (MHz)	Correct Factor (dB)	Ant. Fac. (dB)	Ant. Pol. (H/V)	Reading (dBuV)		Emission (dBuV/m)		Limit Line (dBuV/m)		Over Limit (dBuV/m)	
				PK	AV	PK	AV	PK	AV	PK	AV
2391.43	-22.78	28.06	H	45.3	34.4	50.6	39.7	74.0	54.0	-23.4	-14.3
2400.00	-22.76	28.08	H	61.3	46.3	66.6	51.6	74.0	54.0	-7.4	-2.4
2483.00	-22.51	28.26	H	50.4	39.8	56.2	45.5	74.0	54.0	-17.8	-8.5
2483.50	-22.51	28.26	H	45.0	33.6	50.7	39.4	74.0	54.0	-23.3	-14.6
2391.45	-22.78	28.06	V	44.3	33.6	49.6	38.9	74.0	54.0	-24.4	-15.1
2400.00	-22.76	28.08	V	60.3	46.1	65.6	51.4	74.0	54.0	-8.4	-2.6
2483.00	-22.51	28.26	V	47.5	36.4	53.3	42.2	74.0	54.0	-20.7	-11.8
2483.50	-22.51	28.26	V	45.0	33.7	50.7	39.5	74.0	54.0	-23.3	-14.5

Below 2400MHz :

Horizontal

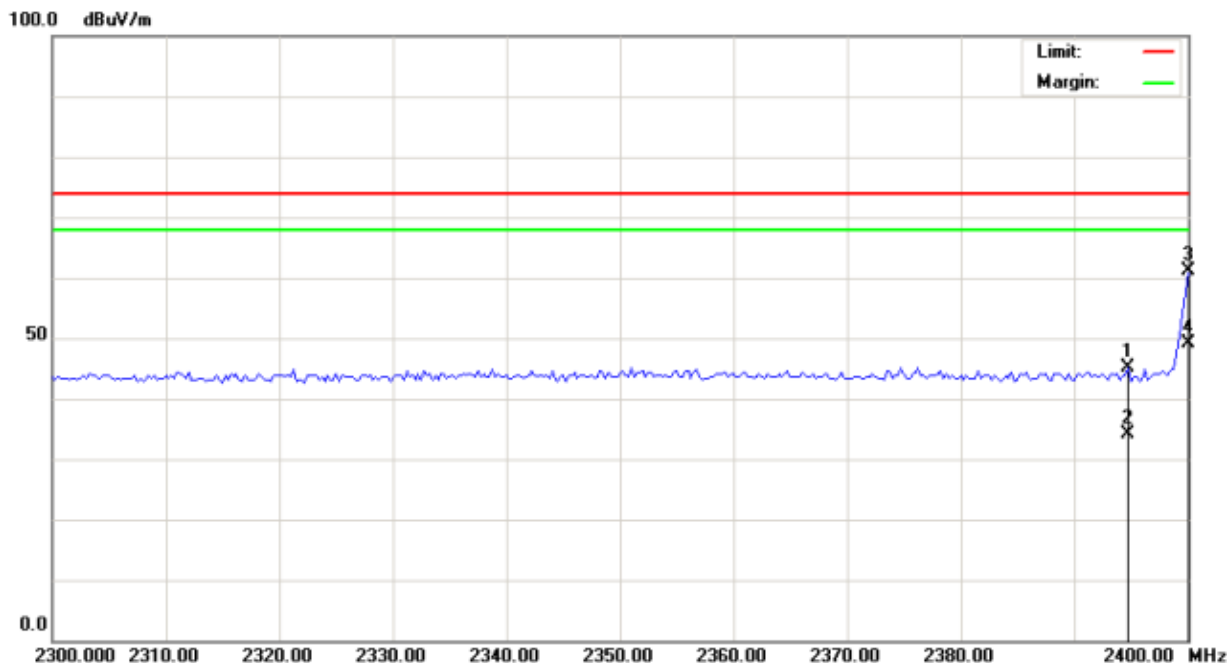



**Spectrum Research & Testing Lab., Inc.**  
No. 101-10, Ling 8,  
Shan-Tong Li, Chung-Li  
City, Taoyuan, Taiwan

# TEST REPORT

Reference No.: A11072604  
Report No.: FCCA11072604  
FCC ID : FSUGMZJR  
Page: 13 of 35  
Date: Aug.18, 2011

Below 2400MHz :

Vertical

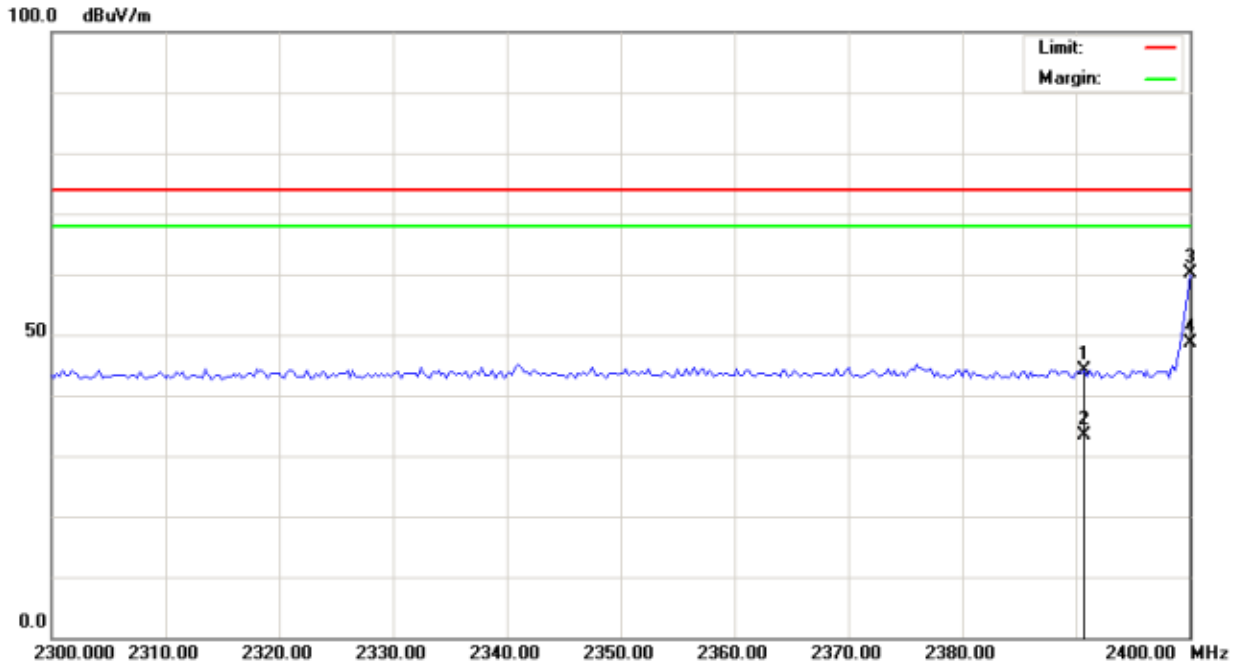



Above 2483.5 MHz :

Horizontal

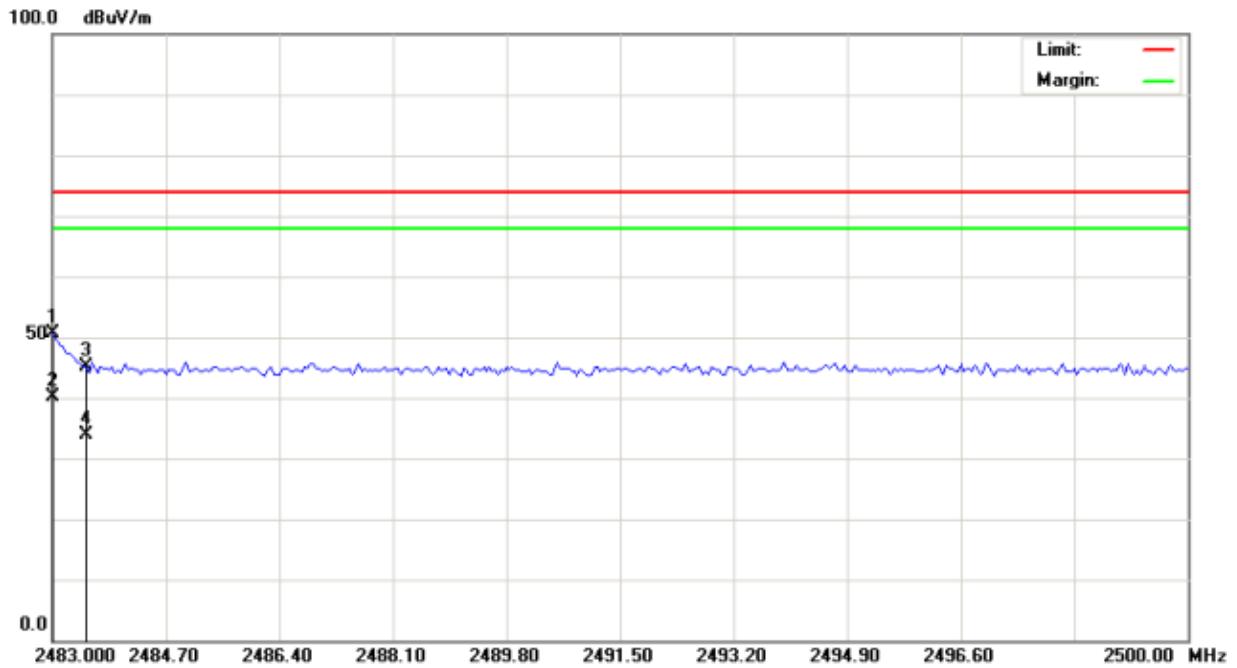

Above 2483.5 MHz :

Vertical

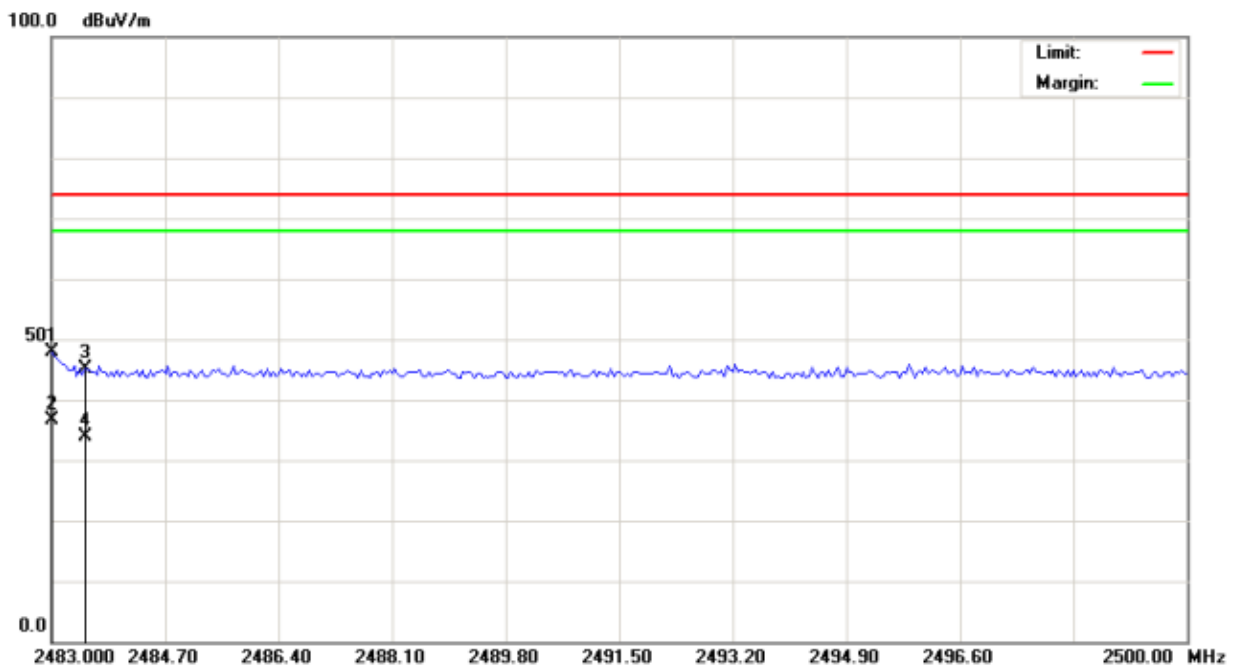



## 4.2 RADIATED EMISSION TEST

### 4.2.1 LIMIT

FCC Part15, Subpart C Section 15.209 limit of radiated emission for frequency below1000MHz. The emissions from an intentional radiator shall not exceed the field strength levels specified in the following table:

FREQUENCY (MHz)	DISTANCE (m)	FIELD STRENGTH (dB $\mu$ V/m)
0.009 - 0.490	300	2400/F(KHz)
0.490 - 1.705	30	24000/F(KHz)
1.705 - 30	30	30
30 - 88	3	40.0
88 - 216	3	43.5
216 - 960	3	46.0
Above 960	3	54.0

FCC Part15, Subpart C Section 15.249 limit of radiated emission for frequency below1000MHz (Average).

FREQUENCY (MHz)	FIELD STRENGTH OF FUNDAMENTAL (millivolts/meter)	FIELD STRENGTH OF HARMONICS (millivolts/meter)
902 - 928	50	500
2400 - 2483.5	50	500
5725 - 5875	50	500
24000 - 24250	250	2500

#### NOTE :

1. In the emission tables above , the tighter limit applies at the band edges.
2. Distance refers to the distance between measuring instrument, antenna, and the closest point of any part of the device or system.
3. 50mV = 94dBuV

FCC Part 15, Section15.35(b) limit of radiated emission for frequency above 1000 MHz

FREQUENCY (MHz)	Class A (dBuV/m) (at 3m)		Class B (dBuV/m) (at 3m)	
	PEAK	AVERAGE	PEAK	AVERAGE
Above 1000	80.0	60.0	74.0	54.0



**Spectrum Research & Testing Lab., Inc.**  
No. 101-10, Ling 8,  
Shan-Tong Li, Chung-Li  
City, Taoyuan, Taiwan

## TEST REPORT

Reference No.: A11072604  
Report No.: FCCA11072604  
FCC ID : FSUGMJJR  
Page: 16 of 35  
Date: Aug.18, 2011

### 4.2.2 TEST EQUIPMENT

The following test equipment was used during the radiated emission test:

EQUIPMENT/ FACILITIES	SPECIFICATIONS	MANUFACTURER	MODEL#/ SERIAL#	DUE DATE OF CAL. & CAL. CENTER
EMI TEST RECEIVER	20 MHz TO 1000 MHz	ROHDE & SCHWARZ	ESVS30 / 841977/003	DEC. 2011 ETC
BI-LOG ANTENNA	30 MHz TO 2 GHz	SCHAFFNER	CBL6141A / 4181	MAY 2012 ETC
OATS	3 – 10 M MEASUREMENT	SRT	SRT-1	NOV. 2011 SRT
COAXIAL CABLE	30M	TIMES	LMR-400 / #30M	MAY 2012 ETC
FILTER	2 LINE, 30A	FIL.COIL	FC-943 / 869	NCR
SPECTRUM ANALYZER	9K-40GHz	R&S	FSP40/ 100093	DEC. 2011 ETC
PRE-AMPLIFIER	1 GHz TO 26.5 GHz	HP	8449B/ 3008A01995	JAN. 2012 ETC
HORN ANTENNA	1 GHz TO 18 GHz	EMCO	3115/ 6881	NOV. 2011 ETC
HORN ANTENNA	18 GHz TO 40 GHz	EMCO	3116/ 00032255	FEB. 2012 ETC
K-TYPE CABLE	15M	HUBER SUHNER	SF 102-40/2*11 /23932/2	MAY 2012 ETC
K-TYPE CABLE	1M	HUBER SUHNER	SF 102-40/2*11 /23934/2	NOV. 2011 ETC

**NOTE:**

1. The calibration interval of the above test equipment is one year and the calibrations are traceable to NML/ROC and NIST/USA.





## 4.2.3 TEST SET-UP 30MHz ~ 1GHz

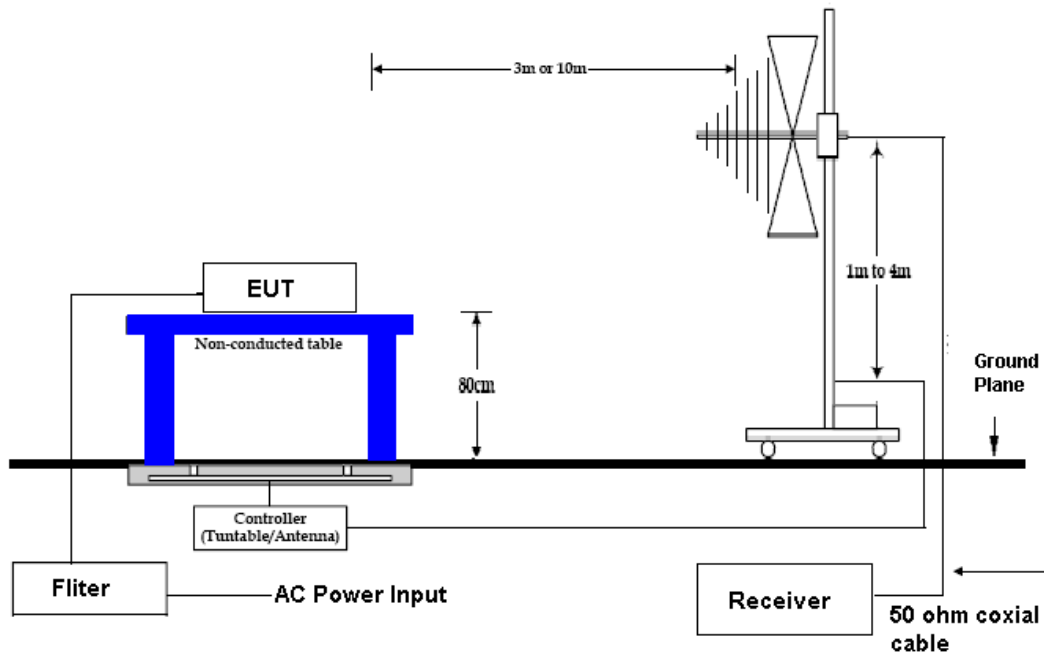

## Above 1GHz

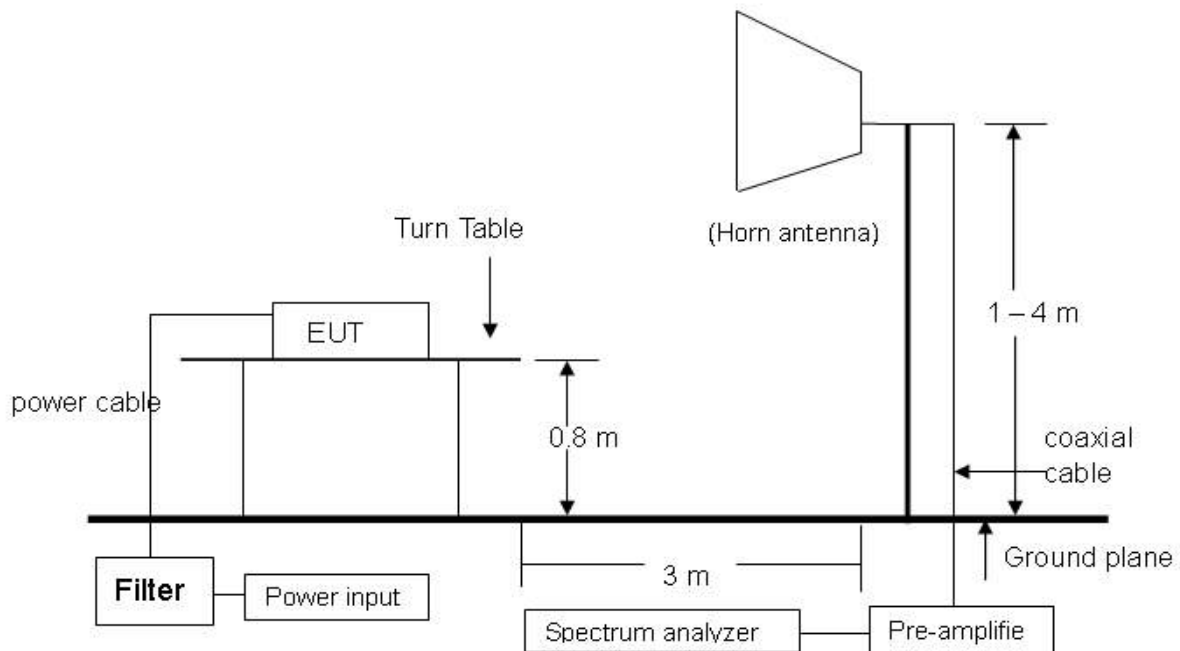

### NOTE :

1. The EUT system was put on a wooden table with 0.8m heights above a ground plane. For the actual test configuration, please refer to the photos of testing.



**Spectrum Research &  
Testing Lab., Inc.**  
No. 101-10, Ling 8,  
Shan-Tong Li, Chung-Li  
City, Taoyuan, Taiwan

## TEST REPORT

Reference No.: A11072604  
Report No.: FCCA11072604  
FCC ID : FSUGMZJR  
Page: 18 of 35  
Date: Aug.18, 2011

### 4.2.4 TEST PROCEDURE

The EUT was tested according to the requirement of ANSI C63.4:2003 and CISPR 22:2003. The measurements were made at an open area test site with 3 meter measurement distance under 1 GHz and with 3m distance above 1GHz. The frequency spectrum measured started from 30 MHz. Under 1 GHz, all readings were quasi-peak values with 120 kHz resolution bandwidth of the test receiver. Above 1 GHz, the measurements were made at an open area test site with 3 meter measurement distance and all readings were peak or average values with 1 MHz resolution bandwidth of the test receiver. The EUT system was operated in all typical methods by users. The cables connected to EUT and support units were moved to find the maximum emission levels for each frequency.

First, find the margin or higher points at least 6 points by software, then use manual to find the maximum data. The procedure is referred on the test procedure of SRT LAB.



## 4.2.5 TEST RESULT

Temperature:	24 °C	Humidity:	55 %RH
Tested By:	Jeff Lo	Tested Mode:	1
Receiver Detector:	Q.P. or AV.	Modulation Type:	GFSK
Frequency Range:	30M – 1GHz	Tested Date:	Aug. 15, 2011

Antenna Polarization : Horizontal

Frequency (MHz)	Cable Loss (dB)	Antenna Factor (dB/m)	Reading Data (dBμV)	Emission Level (dBμV/m)	Limit (dBμV/m)	Margin (dB)	AZ(°)	EL(m)
53.3250	1.13	12.58	3.7	17.4	40.0	-22.6	135	2.54
60.4450	1.20	9.50	7.1	17.8	40.0	-22.2	10	2.49
191.3300	1.90	10.99	7.7	20.6	43.5	-22.9	225	2.15
541.9100	3.36	18.49	4.5	26.4	46.0	-19.6	210	1.96
647.4000	3.69	20.26	2.9	26.8	46.0	-19.2	356	1.85
887.4180	4.45	23.05	2.7	30.2	46.0	-15.8	142	1.79

Antenna Polarization : Vertical

Frequency (MHz)	Cable Loss (dB)	Antenna Factor (dB/m)	Reading Data (dBμV)	Emission Level (dBμV/m)	Limit (dBμV/m)	Margin (dB)	AZ(°)	EL(m)
46.2200	1.06	15.94	4.9	21.9	40.0	-18.1	98	1.41
56.0700	1.16	11.26	6.7	19.1	40.0	-20.9	21	1.53
65.4800	1.20	8.75	10.5	20.5	40.0	-19.6	154	1.12
657.2700	3.71	20.36	2.3	26.4	46.0	-19.6	208	1.09
836.4400	4.24	22.68	2.9	29.8	46.0	-16.2	119	1.15
891.3180	4.46	23.06	7.3	34.8	46.0	-11.2	98	1.41

### NOTE :

1. Measurement uncertainty is +/- 4.73dB.
2. "\*": Measurement does not apply for this frequency.
3. Emission Level = Reading Value + Ant. Factor + Cable Loss.
4. The field strength of other emission frequencies were very low against the limit.



# TEST REPORT

Temperature:	24 °C	Humidity:	55 %RH
Tested By:	Jeff Lo	Tested Mode:	2
Receiver Detector:	Q.P. or AV.	Modulation Type:	GFSK
Frequency Range:	30M – 1GHz	Tested Date:	Aug. 15, 2011

## Antenna Polarization : Horizontal

Frequency (MHz)	Cable Loss (dB)	Antenna Factor (dB/m)	Reading Data (dBμV)	Emission Level (dBμV/m)	Limit (dBμV/m)	Margin (dB)	AZ(°)	EL(m)
53.3600	1.13	12.58	4.3	18.0	40.0	-22.0	159	2.49
68.1100	1.20	8.30	10.2	19.7	40.0	-20.3	20	2.38
191.4400	1.90	10.99	8.0	20.9	43.5	-22.6	135	2.21
473.1080	3.09	17.62	3.3	24.0	46.0	-22.0	315	1.99
625.6100	3.60	19.95	6.0	29.6	46.0	-16.5	79	1.76
875.4300	4.40	23.00	2.4	29.8	46.0	-16.2	352	1.82

## Antenna Polarization : Vertical

Frequency (MHz)	Cable Loss (dB)	Antenna Factor (dB/m)	Reading Data (dBμV)	Emission Level (dBμV/m)	Limit (dBμV/m)	Margin (dB)	AZ(°)	EL(m)
46.2700	1.06	15.94	5.2	22.2	40.0	-17.8	109	1.25
56.3200	1.16	11.26	6.7	19.1	40.0	-20.9	228	1.31
65.4100	1.20	8.75	10.5	20.5	40.0	-19.6	51	1.05
577.4110	3.45	19.14	4.1	26.7	46.0	-19.3	8	1.14
761.3250	3.94	21.94	3.0	28.9	46.0	-17.1	23	1.39
849.0180	4.30	22.88	3.3	30.5	46.0	-15.5	2	1.15

### NOTE :

1. Measurement uncertainty is +/- 4.73dB.
2. "": Measurement does not apply for this frequency.
3. Emission Level = Reading Value + Ant. Factor + Cable Loss.
4. The field strength of other emission frequencies were very low against the limit.



# TEST REPORT

Temperature:	24 °C	Humidity:	55 %RH
Tested By:	Jeff Lo	Tested Mode:	3
Receiver Detector:	Q.P. or AV.	Modulation Type:	GFSK
Frequency Range:	30M – 1GHz	Tested Date:	Aug. 15, 2011

## Antenna Polarization : Horizontal

Frequency (MHz)	Cable Loss (dB)	Antenna Factor (dB/m)	Reading Data (dBμV)	Emission Level (dBμV/m)	Limit (dBμV/m)	Margin (dB)	AZ(°)	EL(m)
53.3110	1.13	12.58	3.7	17.4	40.0	-22.6	12	2.43
191.4400	1.90	10.99	8.7	21.6	43.5	-21.9	156	2.35
332.2700	2.53	14.67	4.6	21.8	46.0	-24.2	279	2.22
562.4780	3.42	18.84	4.2	26.5	46.0	-19.5	253	1.95
696.1700	3.79	20.67	3.3	27.8	46.0	-18.2	141	1.84
853.4700	4.31	22.91	2.7	30.0	46.0	-16.0	53	1.69

## Antenna Polarization : Vertical

Frequency (MHz)	Cable Loss (dB)	Antenna Factor (dB/m)	Reading Data (dBμV)	Emission Level (dBμV/m)	Limit (dBμV/m)	Margin (dB)	AZ(°)	EL(m)
46.2100	1.06	15.94	4.9	21.9	40.0	-18.1	226	1.25
56.3300	1.16	11.26	7.7	20.1	40.0	-19.9	109	1.39
65.4800	1.20	8.75	10.2	20.2	40.0	-19.9	130	1.14
461.1500	3.04	17.45	6.2	26.7	46.0	-19.3	254	1.22
629.2100	3.62	20.01	3.7	27.3	46.0	-18.7	111	1.05
749.3300	3.90	21.88	2.8	28.6	46.0	-17.4	98	1.09

### NOTE :

1. Measurement uncertainty is +/- 4.73dB.
2. "": Measurement does not apply for this frequency.
3. Emission Level = Reading Value + Ant. Factor + Cable Loss.
4. The field strength of other emission frequencies were very low against the limit.



**Spectrum Research & Testing Lab., Inc.**  
No. 101-10, Ling 8,  
Shan-Tong Li, Chung-Li  
City, Taoyuan, Taiwan

# TEST REPORT

Reference No.: A11072604  
Report No.: FCCA11072604  
FCC ID : FSUGMZJR  
Page: 22 of 35  
Date: Aug.18, 2011

Temperature:	24 °C	Humidity:	55 %RH
Tested By:	Jeff Lo	Tested Mode:	4
Receiver Detector:	Q.P. or AV.	Modulation Type:	GFSK
Frequency Range:	30M – 1GHz	Tested Date:	Aug. 15, 2011

Antenna Polarization : Horizontal

Frequency (MHz)	Cable Loss (dB)	Antenna Factor (dB/m)	Reading Data (dBμV)	Emission Level (dBμV/m)	Limit (dBμV/m)	Margin (dB)	AZ(°)	EL(m)
33.4400	0.93	22.50	2.2	25.6	40.0	-14.4	305	2.45
46.2000	1.06	15.94	2.4	19.4	40.0	-20.6	154	2.29
526.3700	3.30	18.31	2.7	24.3	46.0	-21.7	269	2.12
699.4700	3.80	20.69	3.1	27.6	46.0	-18.4	254	1.95
788.2700	4.05	22.05	2.5	28.6	46.0	-17.4	11	1.65
880.3000	4.42	23.02	2.7	30.1	46.0	-15.9	204	1.53

Antenna Polarization : Vertical

Frequency (MHz)	Cable Loss (dB)	Antenna Factor (dB/m)	Reading Data (dBμV)	Emission Level (dBμV/m)	Limit (dBμV/m)	Margin (dB)	AZ(°)	EL(m)
33.4700	0.93	22.50	2.3	25.7	40.0	-14.3	199	1.24
36.7300	0.96	21.00	2.4	24.4	40.0	-15.6	234	1.18
46.2200	1.06	15.94	10.0	27.0	40.0	-13.0	300	1.54
78.2500	1.28	8.16	10.7	20.1	40.0	-19.9	154	1.19
199.7700	1.90	11.71	19.8	33.4	43.5	-10.1	87	1.37
769.0250	3.98	21.98	2.2	28.2	46.0	-17.8	324	1.14

**NOTE :**

1. Measurement uncertainty is +/- 4.73dB.
2. "": Measurement does not apply for this frequency.
3. Emission Level = Reading Value + Ant. Factor + Cable Loss.
4. The field strength of other emission frequencies were very low against the limit.



# TEST REPORT

Temperature:	24 °C	Humidity:	55 %RH
Tested By:	Jeff Lo	Tested Mode:	5
Receiver Detector:	Q.P. or AV.	Modulation Type:	GFSK
Frequency Range:	30M – 1GHz	Tested Date:	Aug. 15, 2011

## Antenna Polarization : Horizontal

Frequency (MHz)	Cable Loss (dB)	Antenna Factor (dB/m)	Reading Data (dBμV)	Emission Level (dBμV/m)	Limit (dBμV/m)	Margin (dB)	AZ(°)	EL(m)
165.1100	1.80	11.50	10.6	23.9	43.5	-19.6	223	2.57
250.0500	2.20	13.20	11.3	26.7	46.0	-19.3	154	2.09
373.4200	2.69	15.65	8.7	27.0	46.0	-19.0	320	2.13
465.4700	3.06	17.51	7.3	27.9	46.0	-18.1	24	1.56
722.4600	3.84	21.23	4.3	29.4	46.0	-16.6	54	1.14
766.3800	3.96	21.96	6.6	32.5	46.0	-13.5	322	1.28

## Antenna Polarization : Vertical

Frequency (MHz)	Cable Loss (dB)	Antenna Factor (dB/m)	Reading Data (dBμV)	Emission Level (dBμV/m)	Limit (dBμV/m)	Margin (dB)	AZ(°)	EL(m)
33.1250	0.93	22.50	4.9	28.3	40.0	-11.7	146	1.54
39.7700	0.99	19.50	5.8	26.3	40.0	-13.7	29	1.11
51.0150	1.11	13.46	10.9	25.5	40.0	-14.5	147	1.26
153.4800	1.73	12.42	13.1	27.3	43.5	-16.3	321	1.34
373.6100	2.69	15.65	19.0	37.3	46.0	-8.7	36	1.15
400.1250	2.80	16.30	12.3	31.4	46.0	-14.6	109	1.06

### NOTE :

1. Measurement uncertainty is +/- 4.73dB.
2. "": Measurement does not apply for this frequency.
3. Emission Level = Reading Value + Ant. Factor + Cable Loss.
4. The field strength of other emission frequencies were very low against the limit.



# TEST REPORT

Temperature:	24 °C	Humidity:	55 %RH
Receiver Detector:	PK. or AV.	Tested Mode:	1
Frequency Range:	1 – 25GHz	Modulation Type:	GFSK
Tested By:	Jeff Lo	Tested Date:	Aug. 15, 2011

Antenna Polarization : Horizontal

Frequency (MHz)	Correct Factor (dB)	Ant. Factor (dB/m)	Reading Data (dB $\mu$ V)		Emission Level (dB $\mu$ V/m)		Limit (dB $\mu$ V/m)		Margin (dB)		AZ (°)	EL (m)
			PK.	AV.	PK.	AV.	PK.	AV.	PK.	AV.		
1830.55	-24.62	26.59	51.2	40.9	53.2	42.9	74.0	54.0	-20.8	-11.1	111	2.33
1842.47	-24.57	26.63	50.9	39.7	53.0	41.8	74.0	54.0	-21.0	-12.2	108	2.31
2008.27	-23.92	27.22	45.8	34.3	49.1	37.6	74.0	54.0	-24.9	-16.4	206	2.21
2301.37	-23.05	27.86	45.5	33.2	50.3	38.0	74.0	54.0	-23.7	-16.0	309	2.18
2437.56	-22.65	28.16	49.3	38.7	54.8	44.2	74.0	54.0	-19.2	-9.8	12	2.14
2595.71	-22.24	28.64	45.5	35.6	51.9	42.0	74.0	54.0	-22.1	-12.0	98	2.11

Antenna Polarization : Vertical

Frequency (MHz)	Correct Factor (dB)	Ant. Factor (dB/m)	Reading Data (dB $\mu$ V)		Emission Level (dB $\mu$ V/m)		Limit (dB $\mu$ V/m)		Margin (dB)		AZ (°)	EL (m)
			PK.	AV.	PK.	AV.	PK.	AV.	PK.	AV.		
1842.61	-24.57	26.63	50.3	39.8	52.3	41.9	74.0	54.0	-21.7	-12.1	91	1.38
2131.43	-23.55	27.49	46.1	35.5	50.1	39.4	74.0	54.0	-23.9	-14.6	144	1.44
2285.46	-23.10	27.83	45.2	34.8	49.9	39.5	74.0	54.0	-24.1	-14.5	166	1.56
2437.44	-22.65	28.16	48.7	37.1	54.2	42.6	74.0	54.0	-19.8	-11.4	132	1.73
2463.57	-22.57	28.22	48.0	37.3	53.7	42.9	74.0	54.0	-20.3	-11.1	255	1.84
2641.51	-22.13	28.81	44.8	32.4	51.5	39.1	74.0	54.0	-22.5	-14.9	247	1.99

**NOTE :**

1. Measurement uncertainty is +/- 4.73dB.
2. "": The Peak reading value also meets average limit and measurement with the average detector is unnecessary.
3. Emission Level = Reading Value + Ant. Factor + Correct Factor (incl.:Cable Loss and Pre-Amplifier Gain)
4. The field strength of other emission frequencies were very low against the limit.
5. (F):The field strength of fundamental frequency.





**Spectrum Research & Testing Lab., Inc.**  
No. 101-10, Ling 8,  
Shan-Tong Li, Chung-Li  
City, Taoyuan, Taiwan

# TEST REPORT

Reference No.: A11072604  
Report No.: FCCA11072604  
FCC ID : FSUGMZJR  
Page: 25 of 35  
Date: Aug.18, 2011

Temperature:	24 °C	Humidity:	55 %RH
Receiver Detector:	PK. or AV.	Tested Mode:	1 (Fundamental)
Frequency Range:	1 – 25GHz	Modulation Type:	GFSK
Tested By:	Jeff Lo	Tested Date:	Aug. 15, 2011

Antenna Polarization : Horizontal

Frequency (MHz)	Correct Factor (dB)	Ant. Factor (dB/m)	Reading Data (dB $\mu$ V)		Emission Level (dB $\mu$ V/m)		Limit (dB $\mu$ V/m)		Margin (dB)		AZ (°)	EL (m)
			PK.	AV.	PK.	AV.	PK.	AV.	PK.	AV.		
2402.00	-22.75	28.08	83.4	77.1	88.7	82.4	114	94.0	-25.3	-11.6	159	1.53
4804.00	-16.80	33.05	39.1	26.4	55.4	42.7	74.0	54.0	-18.6	-11.3	221	1.42
7206.00	-12.81	35.74	34.7	24.2	57.6	47.1	74.0	54.0	-16.4	-6.9	15	1.38
9608.00	-10.12	38.06	28.8	18.1	56.7	46.0	74.0	54.0	-17.3	-8.0	304	1.41
12010.00	-6.38	39.59	24.3	14.8	57.5	48.0	74.0	54.0	-16.5	-6.0	188	1.44
14412.00	-2.40	42.41	16.6	6.4	56.6	46.4	74.0	54.0	-17.4	-7.6	205	1.38

Antenna Polarization : Vertical

Frequency (MHz)	Correct Factor (dB)	Ant. Factor (dB/m)	Reading Data (dB $\mu$ V)		Emission Level (dB $\mu$ V/m)		Limit (dB $\mu$ V/m)		Margin (dB)		AZ (°)	EL (m)
			PK.	AV.	PK.	AV.	PK.	AV.	PK.	AV.		
2402.00	-22.75	28.08	84.4	73.7	89.7	79.0	114	94.0	-24.3	-15.0	147	1.44
4804.00	-16.80	33.05	42.7	31.3	59.0	47.6	74.0	54.0	-15.0	-6.4	25	1.29
7206.00	-12.81	35.74	38.2	26.8	61.1	49.7	74.0	54.0	-12.9	-4.3	321	1.35
9608.00	-10.12	38.06	28.8	18.1	56.7	46.0	74.0	54.0	-17.3	-8.0	229	1.39
12010.00	-6.38	39.59	26.6	16.1	59.8	49.3	74.0	54.0	-14.2	-4.7	333	1.41
14412.00	-2.40	42.41	20.3	10.1	60.3	50.1	74.0	54.0	-13.7	-3.9	155	1.44

## NOTE :

1. Measurement uncertainty is +/- 4.73dB.
2. "F": The Peak reading value also meets average limit and measurement with the average detector is unnecessary.
3. Emission Level = Reading Value + Ant. Factor + Correct Factor (incl.:Cable Loss and Pre-Amplifier Gain)
4. The field strength of other emission frequencies were very low against the limit.
5. (F):The field strength of fundamental frequency.



# TEST REPORT

Temperature:	24 °C	Humidity:	55 %RH
Receiver Detector:	PK. or AV.	Tested Mode:	2
Frequency Range:	1 – 25GHz	Modulation Type:	GFSK
Tested By:	Jeff Lo	Tested Date:	Aug. 15, 2011

Antenna Polarization : Horizontal

Frequency (MHz)	Correct Factor (dB)	Ant. Factor (dB/m)	Reading Data (dB $\mu$ V)		Emission Level (dB $\mu$ V/m)		Limit (dB $\mu$ V/m)		Margin (dB)		AZ (°)	EL (m)
			PK.	AV.	PK.	AV.	PK.	AV.	PK.	AV.		
1745.33	-24.95	26.28	49.5	38.1	50.8	39.4	74.0	54.0	-23.2	-14.6	144	2.38
1830.24	-24.62	26.59	43.5	32.4	45.5	34.4	74.0	54.0	-28.5	-19.6	22	2.31
2008.37	-23.92	27.22	45.8	34.8	49.1	38.1	74.0	54.0	-24.9	-15.9	138	2.27
2085.42	-23.69	27.39	45.8	34.7	49.5	38.4	74.0	54.0	-24.5	-15.6	255	2.25
2255.68	-23.19	27.76	45.8	34.4	50.4	39.0	74.0	54.0	-23.6	-15.0	109	2.17
2637.59	-22.14	28.79	44.8	33.9	51.5	40.6	74.0	54.0	-22.5	-13.4	48	2.11

Antenna Polarization : Vertical

Frequency (MHz)	Correct Factor (dB)	Ant. Factor (dB/m)	Reading Data (dB $\mu$ V)		Emission Level (dB $\mu$ V/m)		Limit (dB $\mu$ V/m)		Margin (dB)		AZ (°)	EL (m)
			PK.	AV.	PK.	AV.	PK.	AV.	PK.	AV.		
1745.58	-24.95	26.28	48.6	38.8	50.0	40.1	74.0	54.0	-24.0	-13.9	316	1.33
1830.27	-24.62	26.59	51.2	40.4	53.2	42.4	74.0	54.0	-20.8	-11.6	258	1.41
1842.55	-24.57	26.63	50.3	39.8	52.3	41.9	74.0	54.0	-21.7	-12.1	169	1.47
2229.28	-23.26	27.70	44.8	33.7	49.3	38.1	74.0	54.0	-24.7	-15.9	99	1.56
2395.21	-22.77	28.07	45.5	34.9	50.8	40.2	74.0	54.0	-23.2	-13.8	109	1.64
2663.47	-22.08	28.89	45.2	34.5	52.0	41.3	74.0	54.0	-22.0	-12.7	37	1.77

**NOTE :**

1. Measurement uncertainty is +/- 4.73dB.
2. "": The Peak reading value also meets average limit and measurement with the average detector is unnecessary.
3. Emission Level = Reading Value + Ant. Factor + Correct Factor (incl.:Cable Loss and Pre-Amplifier Gain)
4. The field strength of other emission frequencies were very low against the limit.
5. (F):The field strength of fundamental frequency.



# TEST REPORT

Temperature:	24 °C	Humidity:	55 %RH
Receiver Detector:	PK. or AV.	Tested Mode:	2 (Fundamental)
Frequency Range:	1 – 25GHz	Modulation Type:	GFSK
Tested By:	Jeff Lo	Tested Date:	Aug. 15, 2011

Antenna Polarization : Horizontal

Frequency (MHz)	Correct Factor (dB)	Ant. Factor (dB/m)	Reading Data (dB $\mu$ V)		Emission Level (dB $\mu$ V/m)		Limit (dB $\mu$ V/m)		Margin (dB)		AZ (°)	EL (m)
			PK.	AV.	PK.	AV.	PK.	AV.	PK.	AV.		
2448.00	-22.61	28.19	83.8	72.6	89.4	78.2	114	94.0	-24.6	-15.8	154	1.52
4896.00	-16.62	33.21	41.4	31.2	58.0	47.8	74.0	54.0	-16.0	-6.2	226	1.43
7344.00	-12.64	36.09	31.5	21.3	55.0	44.8	74.0	54.0	-19.0	-9.2	20	1.39
9792.00	-9.86	38.18	26.6	16.3	54.9	44.6	74.0	54.0	-19.1	-9.4	311	1.42
12240.00	-5.93	39.46	23.1	13.4	56.6	46.9	74.0	54.0	-17.4	-7.1	309	1.55
14688.00	-2.30	41.67	20.5	10.1	59.9	49.5	74.0	54.0	-14.1	-4.5	142	1.62

Antenna Polarization : Vertical

Frequency (MHz)	Correct Factor (dB)	Ant. Factor (dB/m)	Reading Data (dB $\mu$ V)		Emission Level (dB $\mu$ V/m)		Limit (dB $\mu$ V/m)		Margin (dB)		AZ (°)	EL (m)
			PK.	AV.	PK.	AV.	PK.	AV.	PK.	AV.		
2448.00	-22.61	28.19	79.9	69.1	85.5	74.7	114	94.0	-28.5	-19.3	151	1.42
4896.00	-16.62	33.21	38.2	28.3	54.8	44.9	74.0	54.0	-19.2	-9.1	21	1.28
7344.00	-12.64	36.09	34.2	24.7	57.7	48.2	74.0	54.0	-16.3	-5.8	324	1.34
9792.00	-9.86	38.18	25.8	15.5	54.1	43.8	74.0	54.0	-19.9	-10.2	231	1.38
12240.00	-5.93	39.46	23.4	13.3	56.9	46.8	74.0	54.0	-17.1	-7.2	111	1.44
14688.00	-2.30	41.67	20.7	10.5	60.1	49.9	74.0	54.0	-13.9	-4.1	44	1.59

**NOTE :**

1. Measurement uncertainty is +/- 4.73dB.
2. "F": The Peak reading value also meets average limit and measurement with the average detector is unnecessary.
3. Emission Level = Reading Value + Ant. Factor + Correct Factor (incl.:Cable Loss and Pre-Amplifier Gain)
4. The field strength of other emission frequencies were very low against the limit.
5. (F):The field strength of fundamental frequency.



**Spectrum Research & Testing Lab., Inc.**  
No. 101-10, Ling 8,  
Shan-Tong Li, Chung-Li  
City, Taoyuan, Taiwan

# TEST REPORT

Reference No.: A11072604  
Report No.: FCCA11072604  
FCC ID : FSUGMZJR  
Page: 28 of 35  
Date: Aug.18, 2011

Temperature:	24 °C	Humidity:	55 %RH
Receiver Detector:	PK. or AV.	Tested Mode:	3
Frequency Range:	1 – 25GHz	Modulation Type:	GFSK
Tested By:	Jeff Lo	Tested Date:	Aug. 15, 2011

Antenna Polarization : Horizontal

Frequency (MHz)	Correct Factor (dB)	Ant. Factor (dB/m)	Reading Data (dB $\mu$ V)		Emission Level (dB $\mu$ V/m)		Limit (dB $\mu$ V/m)		Margin (dB)		AZ (°)	EL (m)
			PK.	AV.	PK.	AV.	PK.	AV.	PK.	AV.		
1834.44	-24.60	26.60	51.1	40.8	53.1	42.8	74.0	54.0	-20.9	-11.2	112	2.24
1978.42	-24.03	27.12	46.1	35.5	49.2	38.6	74.0	54.0	-24.8	-15.4	159	2.21
2085.59	-23.69	27.39	45.5	34.4	49.2	38.1	74.0	54.0	-24.8	-15.9	156	2.18
2242.17	-23.22	27.73	48.4	37.4	52.9	41.9	74.0	54.0	-21.1	-12.1	254	2.14
2437.56	-22.65	28.16	48.0	37.7	53.6	43.2	74.0	54.0	-20.4	-10.8	32	2.17
2675.69	-22.05	28.93	45.5	34.1	52.4	41.0	74.0	54.0	-21.6	-13.0	188	2.11

Antenna Polarization : Vertical

Frequency (MHz)	Correct Factor (dB)	Ant. Factor (dB/m)	Reading Data (dB $\mu$ V)		Emission Level (dB $\mu$ V/m)		Limit (dB $\mu$ V/m)		Margin (dB)		AZ (°)	EL (m)
			PK.	AV.	PK.	AV.	PK.	AV.	PK.	AV.		
1830.44	-24.62	26.59	51.6	40.9	53.5	42.9	74.0	54.0	-20.5	-11.1	201	1.34
1842.57	-24.57	26.63	50.0	39.4	52.0	41.4	74.0	54.0	-22.0	-12.6	308	1.37
2153.44	-23.49	27.54	49.3	38.1	53.4	42.1	74.0	54.0	-20.6	-11.9	107	1.41
2225.12	-23.27	27.70	47.4	36.6	51.8	41.0	74.0	54.0	-22.2	-13.0	111	1.44
2250.42	-23.20	27.75	46.1	35.5	50.7	40.1	74.0	54.0	-23.3	-14.0	38	1.47
2573.47	-22.29	28.56	45.5	34.7	51.8	41.0	74.0	54.0	-22.2	-13.0	79	1.56

## NOTE :

1. Measurement uncertainty is +/- 4.73dB.
2. "": The Peak reading value also meets average limit and measurement with the average detector is unnecessary.
3. Emission Level = Reading Value + Ant. Factor + Correct Factor (incl.:Cable Loss and Pre-Amplifier Gain)
4. The field strength of other emission frequencies were very low against the limit.
5. (F):The field strength of fundamental frequency.



# TEST REPORT

Temperature:	24 °C	Humidity:	55 %RH
Receiver Detector:	PK. or AV.	Tested Mode:	3 (Fundamental)
Frequency Range:	1 – 25GHz	Modulation Type:	GFSK
Tested By:	Jeff Lo	Tested Date:	Aug. 15, 2011

Antenna Polarization : Horizontal

Frequency (MHz)	Correct Factor (dB)	Ant. Factor (dB/m)	Reading Data (dB $\mu$ V)		Emission Level (dB $\mu$ V/m)		Limit (dB $\mu$ V/m)		Margin (dB)		AZ (°)	EL (m)
			PK.	AV.	PK.	AV.	PK.	AV.	PK.	AV.		
2480.00	-22.52	28.26	83.1	72.4	88.8	78.1	114	94.0	-25.2	-15.9	156	1.54
4960.00	-16.50	33.33	44.0	31.3	60.8	48.1	74.0	54.0	-13.2	-5.9	218	1.41
7440.00	-12.52	36.34	38.9	23.5	62.7	47.3	74.0	54.0	-11.3	-6.7	13	1.37
9920.00	-9.68	38.25	26.6	16.1	55.2	44.7	74.0	54.0	-18.8	-9.3	300	1.4
12400.00	-5.62	39.36	23.8	13.4	57.5	47.1	74.0	54.0	-16.5	-6.9	222	1.48
14800.00	-2.25	41.18	19.1	9.3	58.0	48.2	74.0	54.0	-16.0	-5.8	107	1.59

Antenna Polarization : Vertical

Frequency (MHz)	Correct Factor (dB)	Ant. Factor (dB/m)	Reading Data (dB $\mu$ V)		Emission Level (dB $\mu$ V/m)		Limit (dB $\mu$ V/m)		Margin (dB)		AZ (°)	EL (m)
			PK.	AV.	PK.	AV.	PK.	AV.	PK.	AV.		
2480.00	-22.52	28.26	82.7	72.1	88.4	77.8	114	94.0	-25.6	-16.2	150	1.42
4960.00	-16.50	33.33	39.2	28.3	56.0	45.1	74.0	54.0	-18.0	-8.9	23	1.3
7440.00	-12.52	36.34	30.1	20.9	53.9	44.7	74.0	54.0	-20.1	-9.3	318	1.36
9920.00	-9.68	38.25	27.7	17.4	56.3	46.0	74.0	54.0	-17.7	-8.0	224	1.38
12400.00	-5.62	39.36	23.8	13.5	57.5	47.2	74.0	54.0	-16.5	-6.8	301	1.49
14800.00	-2.25	41.18	20.9	8.8	59.8	47.7	74.0	54.0	-14.2	-6.3	79	1.67

**NOTE :**

1. Measurement uncertainty is +/- 4.73dB.
2. "F": The Peak reading value also meets average limit and measurement with the average detector is unnecessary.
3. Emission Level = Reading Value + Ant. Factor + Correct Factor (incl.:Cable Loss and Pre-Amplifier Gain)
4. The field strength of other emission frequencies were very low against the limit.
5. (F):The field strength of fundamental frequency.



# TEST REPORT

Temperature:	24 °C	Humidity:	55 %RH
Receiver Detector:	PK. or AV.	Tested Mode:	4
Frequency Range:	1 – 25GHz	Modulation Type:	GFSK
Tested By:	Jeff Lo	Tested Date:	Aug. 15, 2011

## Antenna Polarization : Horizontal

Frequency (MHz)	Correct Factor (dB)	Ant. Factor (dB/m)	Reading Data (dB $\mu$ V)		Emission Level (dB $\mu$ V/m)		Limit (dB $\mu$ V/m)		Margin (dB)		AZ (°)	EL (m)
			PK.	AV.	PK.	AV.	PK.	AV.	PK.	AV.		
1830.55	-24.62	26.59	51.2	41.3	53.2	43.3	74.0	54.0	-20.8	-10.7	199	2.22
1842.44	-24.57	26.63	50.3	39.8	52.3	41.9	74.0	54.0	-21.7	-12.1	115	2.18
2437.56	-22.65	28.16	48.0	37.1	53.6	42.6	74.0	54.0	-20.4	-11.4	211	2.15
2459.61	-22.58	28.21	57.0	44.2	62.6	49.8	74.0	54.0	-11.4	-4.2	314	2.11
2471.38	-22.55	28.24	47.4	36.6	53.1	42.3	74.0	54.0	-20.9	-11.7	122	2.09
2641.64	-22.13	28.81	44.5	34.1	51.2	40.8	74.0	54.0	-22.8	-13.2	198	2.04

## Antenna Polarization : Vertical

Frequency (MHz)	Correct Factor (dB)	Ant. Factor (dB/m)	Reading Data (dB $\mu$ V)		Emission Level (dB $\mu$ V/m)		Limit (dB $\mu$ V/m)		Margin (dB)		AZ (°)	EL (m)
			PK.	AV.	PK.	AV.	PK.	AV.	PK.	AV.		
1830.57	-24.62	26.59	51.9	41.4	53.9	43.4	74.0	54.0	-20.1	-10.6	191	1.33
1842.47	-24.57	26.63	50.0	39.9	52.0	42.0	74.0	54.0	-22.0	-12.0	244	1.38
2233.54	-23.25	27.71	45.8	34.4	50.3	38.9	74.0	54.0	-23.7	-15.1	66	1.41
2437.59	-22.65	28.16	48.7	38.1	54.2	43.6	74.0	54.0	-19.8	-10.4	321	1.47
2463.11	-22.57	28.22	61.8	45.5	67.4	51.1	74.0	54.0	-6.6	-2.9	55	1.56
2684.17	-22.03	28.96	46.1	35.4	53.1	42.3	74.0	54.0	-20.9	-11.7	147	1.64

### NOTE :

1. Measurement uncertainty is +/- 4.73dB.
2. "F": The Peak reading value also meets average limit and measurement with the average detector is unnecessary.
3. Emission Level = Reading Value + Ant. Factor + Correct Factor (incl.:Cable Loss and Pre-Amplifier Gain)
4. The field strength of other emission frequencies were very low against the limit.
5. (F):The field strength of fundamental frequency.



# TEST REPORT

Temperature:	20 °C	Humidity:	65 %RH
Receiver Detector:	PK. or AV.	Tested Mode:	5
Frequency Range:	1 – 25GHz	Modulation Type:	GFSK
Tested By:	Jeff Lo	Tested Date:	Aug. 15, 2011

Antenna Polarization : Horizontal

Frequency (MHz)	Correct Factor (dB)	Ant. Factor (dB/m)	Reading Data (dBμV)		Emission Level (dBμV/m)		Limit (dBμV/m)		Margin (dB)		AZ (°)	EL (m)
			PK.	AV.	PK.	AV.	PK.	AV.	PK.	AV.		
1111.41	-28.11	24.47	52.5	40.1	48.9	36.5	74.0	54.0	-25.1	-17.5	10	2.35
1842.62	-24.57	26.63	49.6	38.8	51.7	40.9	74.0	54.0	-22.3	-13.1	256	2.27
2161.25	-23.46	27.55	44.5	33.4	48.6	37.5	74.0	54.0	-25.4	-16.5	314	2.24
2310.11	-23.02	27.88	44.2	32.1	49.1	37.0	74.0	54.0	-24.9	-17.0	33	2.21
2437.49	-22.65	28.16	48.0	37.1	53.6	42.6	74.0	54.0	-20.4	-11.4	55	2.11
2675.56	-22.05	28.93	44.2	34.4	51.1	41.3	74.0	54.0	-22.9	-12.7	188	2.08

Antenna Polarization : Vertical

Frequency (MHz)	Correct Factor (dB)	Ant. Factor (dB/m)	Reading Data (dBμV)		Emission Level (dBμV/m)		Limit (dBμV/m)		Margin (dB)		AZ (°)	EL (m)
			PK.	AV.	PK.	AV.	PK.	AV.	PK.	AV.		
1842.44	-24.57	26.63	49.6	38.8	51.7	40.9	74.0	54.0	-22.3	-13.1	191	1.33
2131.51	-23.55	27.49	44.8	33.6	48.8	37.5	74.0	54.0	-25.2	-16.5	44	1.45
2229.25	-23.26	27.70	44.5	33.1	49.0	37.5	74.0	54.0	-25.0	-16.5	61	1.47
2310.17	-23.02	27.88	44.5	32.5	49.4	37.4	74.0	54.0	-24.6	-16.6	147	1.55
2437.45	-22.65	28.16	47.4	36.4	52.9	41.9	74.0	54.0	-21.1	-12.1	259	1.59
2667.11	-22.07	28.90	43.9	31.3	50.7	38.1	74.0	54.0	-23.3	-15.9	111	1.61

**NOTE :**

1. Measurement uncertainty is +/- 4.73dB.
2. "\*": The Peak reading value also meets average limit and measurement with the average detector is unnecessary.
3. Emission Level = Reading Value + Ant. Factor + Correct Factor (incl.:Cable Loss and Pre-Amplifier Gain)
4. The field strength of other emission frequencies were very low against the limit.
5. (F):The field strength of fundamental frequency.



**Spectrum Research &  
Testing Lab., Inc.**  
No. 101-10, Ling 8,  
Shan-Tong Li, Chung-Li  
City, Taoyuan, Taiwan

## **TEST REPORT**

Reference No.: A11072604  
Report No.: FCCA11072604  
FCC ID : FSUGMZJR  
Page: 32 of 35  
Date: Aug.18, 2011

### **5. Antenna application**

#### **5.1 Antenna requirement**

The EUT's antenna is met the requirement of FCC part15C section15.203 and 15.204.

#### **5.2 Result**

The EUT's antenna used a PCB printed. Gain of antenna types is -3dBi that meet the requirement.





## 6. PHOTOS OF TESTING

- Radiated test (below 1G , TX & Standby)





- Radiated test (above 1G , TX & Standby)





**Spectrum Research & Testing Lab., Inc.**  
No. 101-10, Ling 8,  
Shan-Tong Li, Chung-Li  
City, Taoyuan, Taiwan

## TEST REPORT

Reference No.: A11072604  
Report No.: FCCA11072604  
FCC ID : FSUGMZJR  
Page: 35 of 35  
Date: Aug.18, 2011

### 7. TERMS OF ABBREVIATION

AV.	Average detection
AZ(°)	Turn table azimuth
Correct.	Correction
EL(m)	Antenna height (meter)
EUT	Equipment Under Test
Horiz.	Horizontal direction
LISN	Line Impedance Stabilization Network
NSA	Normalized Site Attenuation
Q.P.	Quasi-peak detection
SRT Lab	Spectrum Research & Testing Laboratory, Inc.
Vert.	Vertical direction