



FCC TEST REPORT

for

Wireless Extender & Router

MODEL: WR300NR

Brand: Diamond Multimedia

Test Report Number:

C130125Z02-RP1

Issued Date: March 4, 2013

Issued for

Best Data Products Inc.

20740 Plummer Street, Chatsworth CA 91311, U.S.A

Issued by:

Compliance Certification Services (Shenzhen) Inc.

No.10-1 Mingkeda Logistics park, No.18, Huanguan South Rd.,

Guan Lan Town, Baoan District, Shenzhen, China

TEL: 86-755-28055000

FAX: 86-755-28055221



TESTING CERT #2861.01

Note: *This report shall not be reproduced except in full, without the written approval of Compliance Certification Services Inc. This document may be altered or revised by Compliance Certification Services Inc. personnel only, and shall be noted in the revision section of the document. The client should not use it to claim product endorsement by TAF, A2LA, NVLAP, NIST or any government agencies. The test results in the report only apply to the tested sample.*



Revision History

Rev.	Issue No.	Revisions	Effect Page	Revised By
00	C130125Z02-RP1	Initial Issue	ALL	Sunny Wang



TABLE OF CONTENTS

1 TEST CERTIFICATION	4
2 TEST RESULT SUMMARY	5
3 EUT DESCRIPTION	6
4 TEST METHODOLOGY	7
4.1. DESCRIPTION OF TEST MODES.....	7
5 SETUP OF EQUIPMENT UNDER TEST	8
5.1. DESCRIPTION OF SUPPORT UNITS.....	8
5.2. CONFIGURATION OF SYSTEM UNDER TEST.....	8
6 FACILITIES AND ACCREDITATIONS	9
6.1. FACILITIES.....	9
6.2. ACCREDITATIONS.....	9
6.3. MEASUREMENT UNCERTAINTY.....	9
7 FCC PART 15.247 REQUIREMENTS	10
7.1. POWER LINE CONDUCTED EMISSIONS MEASUREMENT.....	10
7.2. SPURIOUS EMISSIONS MEASUREMENT.....	14
7.3. 6dB BANDWIDTH MEASUREMENT.....	51
7.4. PEAK OUTPUT POWER.....	63
7.5. BAND EDGES MEASUREMENT.....	75
7.6. PEAK POWER SPECTRAL DENSITY MEASUREMENT.....	93



1 TEST CERTIFICATION

Product	Wireless Extender & Router
Model	WR300NR
Brand	Diamond Multimedia
Tested	January 25~March 4, 2013
Applicant	Best Data Products Inc. 20740 Plummer Street, Chatsworth CA 91311, U.S.A
Manufacturer	Winstars Technology Limited Block 4, TaiSong Industrial Park, Dalang Street, LongHua Town, Bao'an district, Shenzhen, China

APPLICABLE STANDARDS			
Standard	Test Type	Standard	Test Type
15.207(a)	Power Line Conducted Emissions	15.247(d) 15.209(a)	<ul style="list-style-type: none"> ● Spurious Emissions ● Conducted Measurement ● Radiated Emissions
15.247(a)(2)	6dB Bandwidth Measurement	15.247(b)(3) 15.247(b)(4)	Peak Power Measurement
15.247(d)	Band Edges Measurement	15.247(e)	Peak Power Spectral Density

We hereby certify that:

The above equipment was tested by Compliance Certification Services Inc. The test data, data evaluation, test procedures, and equipment configurations shown in this report were made in accordance with the procedures given in **ANSI C63.4: 2009** and the energy emitted by the sample EUT tested as described in this report is in compliance with the requirements of FCC Rules Part 15.207, 15.209, 15.247.

The test results of this report relate only to the tested sample EUT identified in this report.

Approved by:

Reviewed by:

Tom Gan
Supervisor of EMC Dept.
Compliance Certification Service Inc.

Ruby Zhang
Supervisor of Report Dept.
Compliance Certification Service Inc.



2 TEST RESULT SUMMARY

APPLICABLE STANDARDS			
Standard	Test Type	Result	Remark
15.247(a)(2)	6dB Bandwidth Measurement	Pass	Meet the requirement of limit.
15.247(b)(3) 15.247(b)(4)	Peak Power Measurement	Pass	Meet the requirement of limit.
15.247(d)	Band Edges Measurement	Pass	Meet the requirement of limit.
15.247(e)	Peak Power Spectral Density	Pass	Meet the requirement of limit.
15.247(d) 15.209(a)	<ul style="list-style-type: none">● Spurious Emissions● Conducted Measurement● Radiated Emissions	Pass	Meet the requirement of limit.
15.207(a)	Power line Conducted Emissions	Pass	Meet the requirement of limit.

- Note: 1. The statements of test result on the above are decided by the request of test standard only; the measurement uncertainties are not factored into this compliance determination.
2. The information of measurement uncertainty is available upon the customer's request.



3 EUT DESCRIPTION

Product	Wireless Extender & Router
Model Number	WR300NR
Brand	Diamond Multimedia
Model Discrepancy	N/A
Serial Number	C130125Z02-RP1
Received Date	January 25, 2013
Power Supply	100-240V, 50-60Hz
Frequency Range	IEEE 802.11b/g: 2412 ~ 2462 MHz IEEE 802.11n HT20 : 2412 ~ 2462 MHz IEEE 802.11n HT40 : 2422MHz~ 2452MHz
Transmit Power	IEEE 802.11b mode: 8.19dBm(Antenna 1) IEEE 802.11g mode: 4.70dBm(Antenna 1) IEEE 802.11n HT20 MHz mode: 11.31dBm(Combine with Antenna 0 and Antenna 1) IEEE 802.11n HT40 MHz mode: 9.37dBm (Combine with Antenna 0 and Antenna 1)
Modulation Technique	IEEE 802.11b mode: DSSS(CCK,QPSK, BPSK) IEEE 802.11g mode: OFDM (BPSK/QPSK/16QAM/64QsAM) IEEE 802.11n HT20 MHz mode: OFDM (BPSK/QPSK/16QAM/64QAM) IEEE 802.11n HT40 MHz mode: OFDM (BPSK/QPSK/16QAM/64QAM)
Transmit Data Rate	802.11b: 11Mbps(CCK) with fall back rates of 5.5/2/1Mbps 802.11g: 54Mbps with fall back rates of 48/36/24/18/12/9/6Mbps IEEE 802.11n HT20: 130.0Mbps with fall back rates of 117/ 104.0/78.0 /65.0/58.5/52.0/39.0/26.0/19.5/13.5/13.0/6.5 Mbps IEEE 802.11n HT40: 270.0Mbps with fall back rates of 243.0/216.0/ 162.0/135.0/121.5/ 108.0/81.0/54.0/40.5/27.0/13.5 Mbps
Number of Channels	IEEE 802.11b mode: 11 Channels IEEE 802.11g mode: 11 Channels IEEE 802.11n HT20 MHz mode: 11 Channels IEEE 802.11n HT40 MHz mode: 7 Channels
Antenna Specification	Integrated Antenna with 2.0dBi gain (Max) (Antenna 0) Integrated Antenna with 2.0dBi gain (Max) (Antenna 1) Total Antenna=2.0 + 10Log2=5.01

Note: 1. The sample selected for test was engineering sample that approximated to production product and was provided by manufacturer.

2. This submittal(s) (test report) is intended for FCC ID: **FN6-WR300NR** filing to comply with Section 15.207, 15.209 and 15.247 of the FCC Part 15, Subpart C Rules.



4 TEST METHODOLOGY

4.1. DESCRIPTION OF TEST MODES

The EUT has been tested under operating condition.

Software used to control the EUT for staying in continuous transmitting and receiving mode is programmed.

Test Item	Test mode	Worse mode
Conducted Emission	Mode 1: Normal	<input checked="" type="checkbox"/>
Radiated Emission	Mode 1: TX	<input checked="" type="checkbox"/>

After verification, all tests were carried out with the worst case test modes as shown below except radiated spurious emission below 1GHz, which worst case was in normal link mode only, and power line conducted emission below 30MHz, which worst case was in normal link mode.

IEEE802.11b mode: Channel Low (2412MHz), Channel Mid (2437MHz) and Channel High(2462MHz) with 1Mbps data rate were chosen for full testing.

IEEE802.11g mode: Channel Low (2412MHz), Channel Mid (2437MHz) and Channel High (2462MHz) with 6Mbps data rate were chosen for full testing.

IEEE 802.11n HT20 MHz mode: Channel Low (2412MHz), Channel Mid (2437MHz) and Channel High (2462MHz) with 6.5Mbps data rate were chosen for full testing.

IEEE 802.11n HT40 MHz mode: Channel Low (2422MHz), Channel Mid (2437MHz) and Channel High (2452MHz) with 13.5Mbps data rate were chosen for full testing.

The field strength of spurious radiation emission was measured in the following position: EUT stand-up position (Y mode) and lie-down position (X, Z mode) The following data show only the worst case setup.

The worst case (Y axis) was reported.



5 SETUP OF EQUIPMENT UNDER TEST

5.1. DESCRIPTION OF SUPPORT UNITS

The EUT has been tested as an independent unit together with other necessary accessories or support units. The following support units or accessories were used to form a representative test configuration during the tests.

No.	Equipment	Model No.	Serial No.	FCC ID	Brand	Data Cable	Power Cord
1	Notebook	LENOVO	WB04591721	N/A	LENOVO	Unshielded, 1.50m	Unshielded, 2.80m
2	Notebook	LENOVO	WB0861612	N/A	LENOVO	Unshielded, 1.50m	Unshielded, 2.80m

Note:

- 1) All the equipment/cables were placed in the worst-case configuration to maximize the emission during the test.
- 2) Grounding was established in accordance with the manufacturer's requirements and conditions for the intended use.

5.2. CONFIGURATION OF SYSTEM UNDER TEST

See test photographs attached in Appendix II for the actual connections between EUT and support equipment.



6 FACILITIES AND ACCREDITATIONS

6.1. FACILITIES

All measurement facilities used to collect the measurement data are located at **No.10-1 Mingkeda Logistics park, No.18, Huanguan South Rd., Guan Lan Town, Baoan District, Shenzhen, China**

The sites are constructed in conformance with the requirements of ANSI C63.4, ANSI C63.7 and CISPR Publication 22. All receiving equipment conforms to CISPR Publication 16-1, "Radio Interference Measuring Apparatus and Measurement Methods."

6.2. ACCREDITATIONS

Our laboratories are accredited and approved by the following accreditation body according to ISO/IEC 17025.

USA	A2LA
China	CNAS

The measuring facility of laboratories has been authorized or registered by the following approval agencies.

USA	FCC
Japan	VCCI(C-3478, R-3135, T-652, G-624)
Canada	INDUSTRY CANADA
Taiwan	BSMI
Norway	Nemko

Copies of granted accreditation certificates are available for downloading from our web site, <http://www.ccsrf.com>

6.3. MEASUREMENT UNCERTAINTY

Where relevant, the following measurement uncertainty levels have been estimated for tests performed on the EUT as specified in CISPR 16-4-2:

Measurement	Frequency	Uncertainty
Conducted emissions	9kHz~30MHz	+/- 3.18dB
Radiated emissions	30MHz ~ 200MHz	+/- 3.79dB
	200MHz ~1000MHz	+/- 3.62dB
	Above 1000MHz	+/- 5.04dB
Band Edges	+/-0.182 dB	

This uncertainty represents an expanded uncertainty expressed at approximately the 95% confidence level using a coverage factor of k=2. The measured result is above (below) the specification limit by a margin less than the measurement uncertainty; it is therefore not possible to state compliance based on the 95% level of confidence. However, the result indicates that compliance (non-compliance) is more probable than non-compliance) with the specification limit.



7 FCC PART 15.247 REQUIREMENTS

7.1. POWER LINE CONDUCTED EMISSIONS MEASUREMENT

7.1.1. LIMITS OF CONDUCTED EMISSIONS MEASUREMENT

According to §15.207(a), except as shown in paragraphs (b) and (c) of this section, for an intentional radiator that is designed to be connected to the public utility (AC) power line, the radio frequency voltage that is conducted back onto the AC power line on any frequency or frequencies within the band 150 kHz to 30 MHz shall not exceed the limits in the following table, as measured using a 50 μH/50 ohms line impedance stabilization network (LISN). Compliance with the provisions of this paragraph shall be based on the measurement of the radio frequency voltage between each power line and ground at the power terminal. The lower limit applies at the boundary between the frequency ranges.

Frequency Range (MHz)	Limits (dBμV)	
	Quasi-peak	Average
0.15 to 0.50	66 to 56*	56 to 46*
0.50 to 5	56	46
5 to 30	60	50

NOTE:

- (1) The lower limit shall apply at the transition frequencies.
- (2) The limit decreases in line with the logarithm of the frequency in the range of 0.15 to 0.50 MHz.
- (3) All emanations from a class A/B digital device or system, including any network of conductors and apparatus connected thereto, shall not exceed the level of field strengths specified above.

7.1.2. TEST INSTRUMENTS

Conducted Emission Test Site					
Name of Equipment	Manufacturer	Model Number	Serial Number	Last Calibration	Due Calibration
ESCI EMI TEST RECEIVER.ESCI	ROHDE&SCHWARZ	ESCI	100783	03/17/2012	03/17/2013
LISN(EUT)	ROHDE&SCHWARZ	ENV216	101543	09/20/2012	09/20/2013
LISN	EMCO	3825/2	8901-1459	03/19/2012	03/19/2013
Temp. / Humidity Meter	VICTOR	HTC-1	2	03/20/2012	03/20/2013
Test S/W	FARAD	EZ-EMC/ CCS-3A1-CE			

- NOTE:** 1. The calibration interval of the above test instruments is 12 months and the calibrations are traceable to NML/ROC and NIST/USA.
 2. N.C.R = No Calibration Request.



7.1.3. TEST PROCEDURES (please refer to measurement standard)

- The EUT and Support equipment, if needed, was placed on a non-conducted table, which is 0.8m above the ground plane and 0.4m away from the conducted wall.
- The test equipment EUT installed received AC main power, through a Line Impedance Stabilization Network (LISN), which supplied power source and was grounded to the ground plane. All support equipment power received from a second LISN. The two LISNs provide 50 ohm/ 50uH of coupling impedance for the measuring instrument.
- The EUT test program was started. Emissions were measured on each current carrying line of the EUT using an EMI Test Receiver connected to the LISN powering the EUT.
- The frequency range from 150 kHz to 30 MHz was searched. The test data of the worst-case condition(s) was recorded. Emission levels under limit 20dB were not recorded.



7.1.4. TEST SETUP

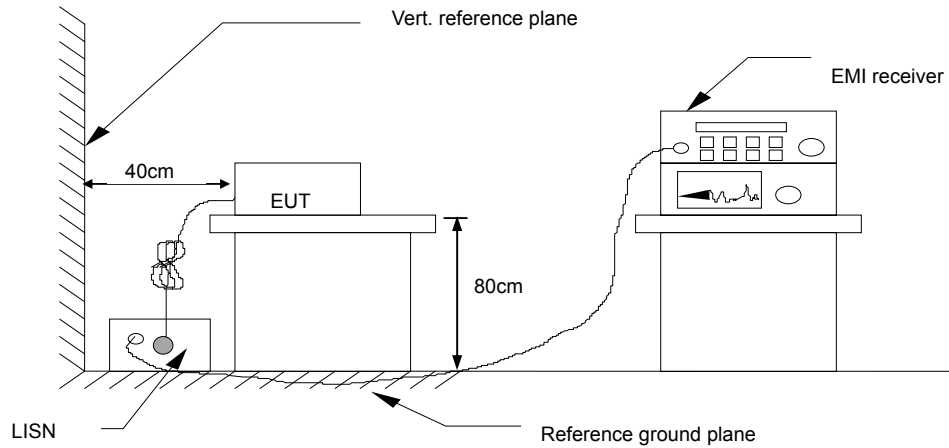

For the actual test configuration, please refer to the related item - Photographs of the Test Configuration.

7.1.5. DATA SAMPLE

Frequency (MHz)	QuasiPeak Reading (dBuV)	Average Reading (dBuV)	Correction Factor (dB)	QuasiPeak Result (dBuV)	Average Result (dBuV)	QuasiPeak Limit (dBuV)	Average Limit (dBuV)	QuasiPeak Margin (dB)	Average Margin (dB)	Remark (Pass/Fail)
X.XXXX	32.69	25.65	11.52	44.21	37.17	65.78	55.79	-21.57	-18.62	Pass

- Factor = Insertion loss of LISN + Cable Loss
- Result = Quasi-peak Reading/ Average Reading + Factor
- Limit = Limit stated in standard
- Margin = Result (dBuV) – Limit (dBuV)



7.1.6. TEST RESULTS

Model No.	WR300NR	RBW,VBW	9 kHz
Environmental Conditions	22°C, 45% RH	Test Mode	Mode 1
Tested by	Bill Peng	Line	L1

(The chart below shows the highest readings taken from the final data.)

Frequency (MHz)	QuasiPeak Reading (dBuV)	Average Reading (dBuV)	Correction Factor (dB)	QuasiPeak Result (dBuV)	Average Result (dBuV)	QuasiPeak Limit (dBuV)	Average Limit (dBuV)	QuasiPeak Margin (dB)	Average Margin (dB)	Remark (Pass/Fail)
0.4530	44.30	34.87	9.68	53.98	44.55	56.82	46.82	-2.84	-2.27	Pass
0.5260	40.20	32.33	9.70	49.90	42.03	56.00	46.00	-6.10	-3.97	Pass
1.1300	39.30	32.62	9.68	48.98	42.30	56.00	46.00	-7.02	-3.70	Pass
1.2059	39.65	32.58	9.68	49.33	42.26	56.00	46.00	-6.67	-3.74	Pass
3.5820	40.87	31.69	9.72	50.59	41.41	56.00	46.00	-5.41	-4.59	Pass
5.5500	33.87	22.63	9.76	43.63	32.39	60.00	50.00	-16.37	-17.61	Pass

REMARKS: L1 = Line One (Live Line)

Model No.	WR300NR	RBW,VBW	9 kHz
Environmental Conditions	22°C, 45% RH	Test Mode	Mode 1
Tested by	Bill Peng	Line	L2

(The chart below shows the highest readings taken from the final data.)

Frequency (MHz)	QuasiPeak Reading (dBuV)	Average Reading (dBuV)	Correction Factor (dB)	QuasiPeak Result (dBuV)	Average Result (dBuV)	QuasiPeak Limit (dBuV)	Average Limit (dBuV)	QuasiPeak Margin (dB)	Average Margin (dB)	Remark (Pass/Fail)
0.4540	36.54	34.09	9.69	46.23	43.78	56.80	46.80	-10.57	-3.02	Pass
0.8340	28.72	20.99	9.67	38.39	30.66	56.00	46.00	-17.61	-15.34	Pass
1.5700	29.59	21.88	9.69	39.28	31.57	56.00	46.00	-16.72	-14.43	Pass
3.7540	44.85	25.88	9.75	54.60	35.63	56.00	46.00	-1.40	-10.37	Pass
10.4740	28.99	17.94	9.81	38.80	27.75	60.00	50.00	-21.20	-22.25	Pass
19.9940	28.12	2.18	10.10	38.22	12.28	60.00	50.00	-21.78	-37.72	Pass

REMARKS: L2 = Line Two (Neutral Line)



7.2. SPURIOUS EMISSIONS MEASUREMENT

7.2.1. LIMITS OF CONDUCTED EMISSIONS MEASUREMENT

§15.247(d) specifies that in any 100 kHz bandwidth outside of the authorized frequency band, the power shall be attenuated according to the following conditions:

If the peak output power procedure is used to measure the fundamental emission power to demonstrate compliance to 15.247(b)(3) requirements, then the peak conducted output power measured within any 100 kHz outside the authorized frequency band shall be attenuated by at least 20 dB relative to the maximum measured in-band peak PSD level.

If the average output power procedure is used to measure the fundamental emission power to demonstrate compliance to 15.247(b)(3) requirements, then the power in any 100 kHz outside of the authorized frequency band shall be attenuated by at least 30 dB relative to the maximum measured in-band average PSD level.

In addition, radiated emissions which fall in the restricted bands, as defined in §15.205(a), must also comply with the radiated emission limits specified in 15.209(a) (see Section 15.205(c)).

7.2.2. TEST INSTRUMENTS

Name of Equipment	Manufacturer	Model	Serial Number	Last Calibration	Due Calibration
Spectrum Analyzer	Agilent	E4446A	US44300399	03/19/2012	03/19/2013

7.2.3. TEST PROCEDURE (please refer to measurement standard)

Conducted RF measurements of the transmitter output were made to confirm that the EUT antenna port conducted emissions meet the specified limit and to identify any spurious signals that require further investigation or measurements on the radiated emissions site.

The transmitter output is connected to the spectrum analyzer. The resolution bandwidth is set to 100 kHz. The video bandwidth is set to 300 kHz.

Measurements are made over the 30MHz to 26GHz range with the transmitter set to the lowest, middle, and highest channels.



7.2.4. TEST RESULTS

Test Plot

IEEE 802.11b mode(Antenna 1)

CH Low (30MHz ~2.9GHz)

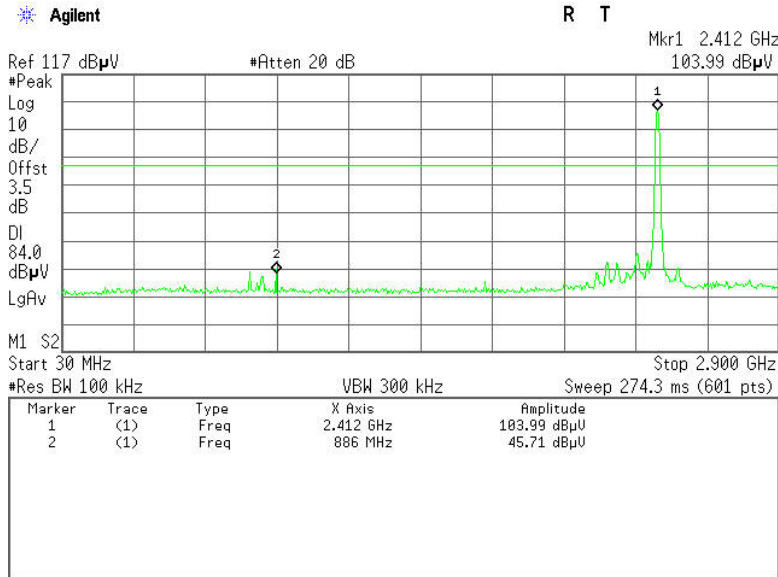

CH Low (2.9GHz ~26.5GHz)

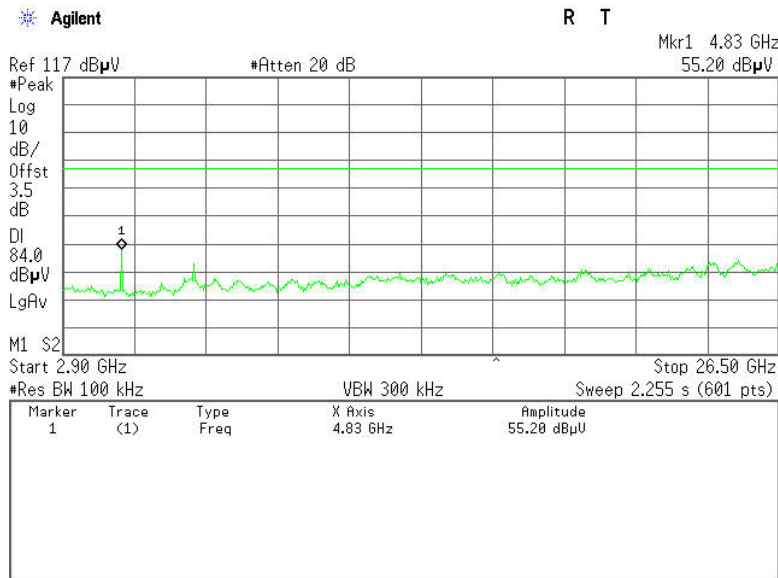



CH Mid (30MHz ~2.9GHz)

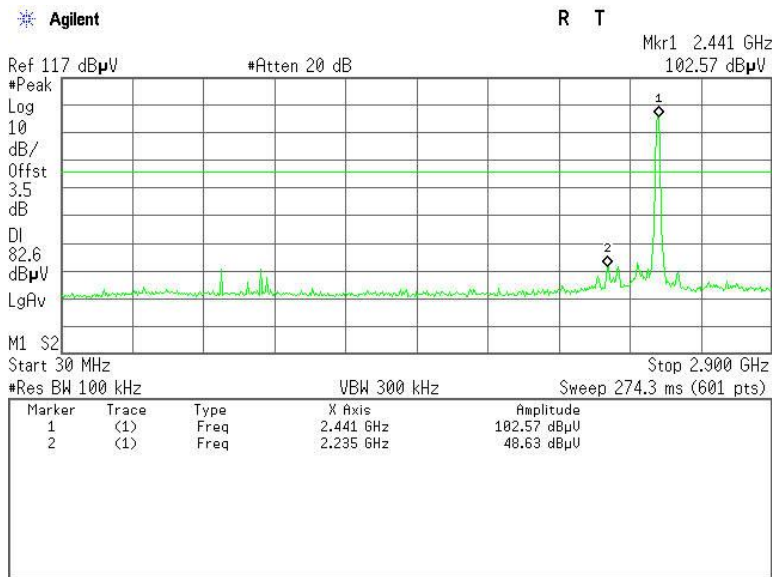

CH Mid (2.9GHz ~26.5GHz)

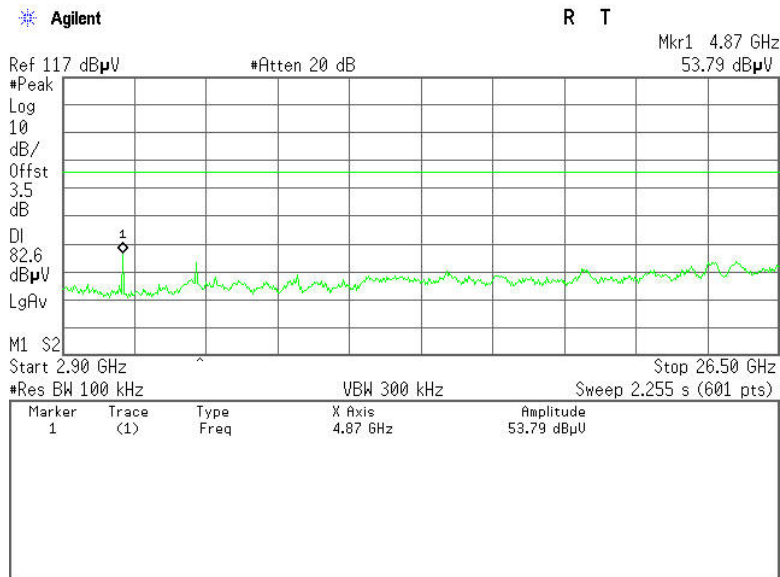



CH High (30MHz ~2.9GHz)

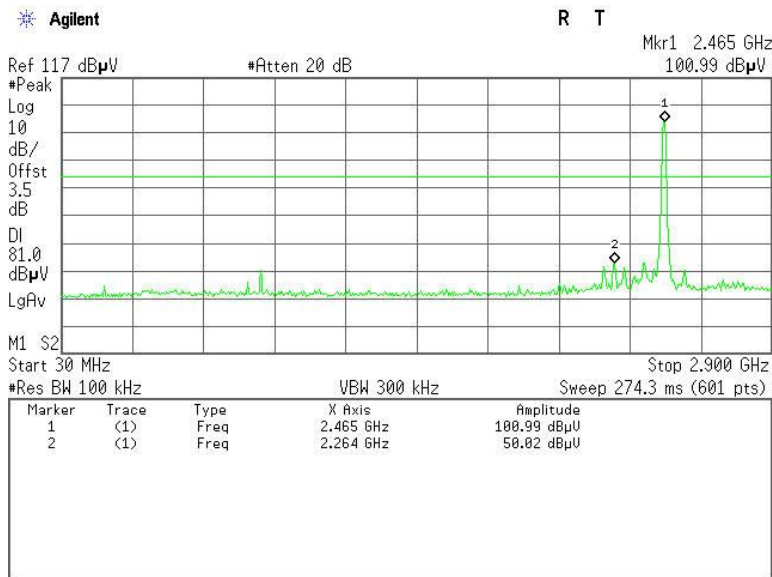

CH High (2.9GHz ~26.5GHz)

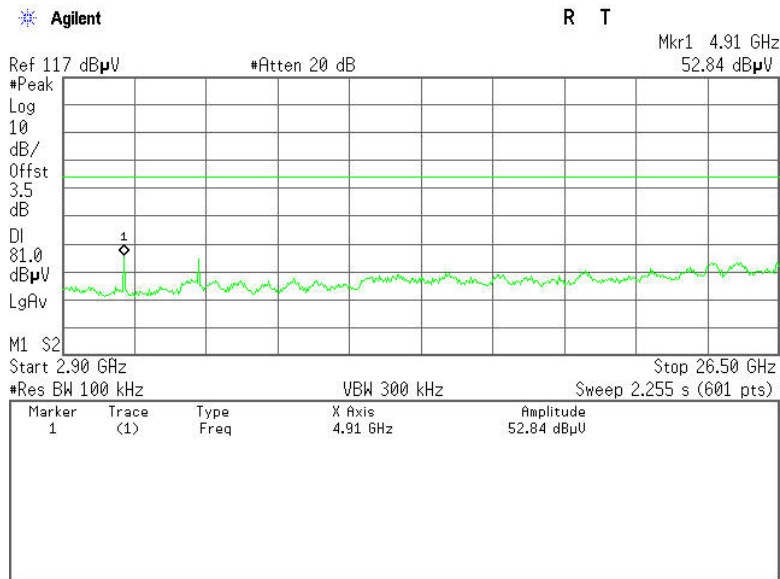



IEEE 802.11g mode(Antenna 1)
CH Low (30MHz ~2.9GHz)

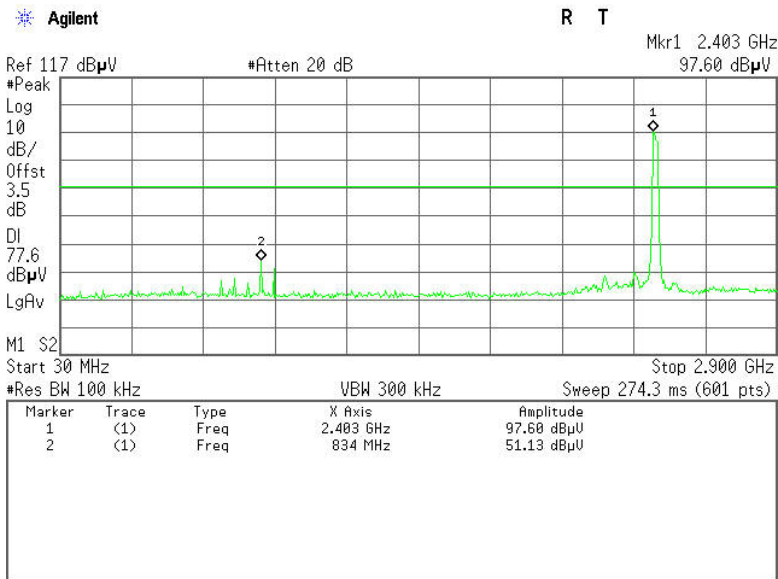

CH Low (2.9GHz ~26.5GHz)

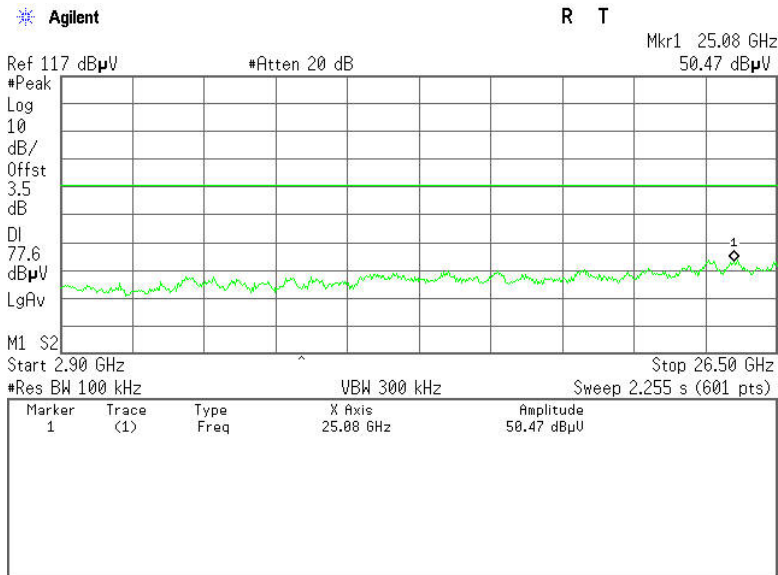



CH Mid (30MHz ~2.9GHz)

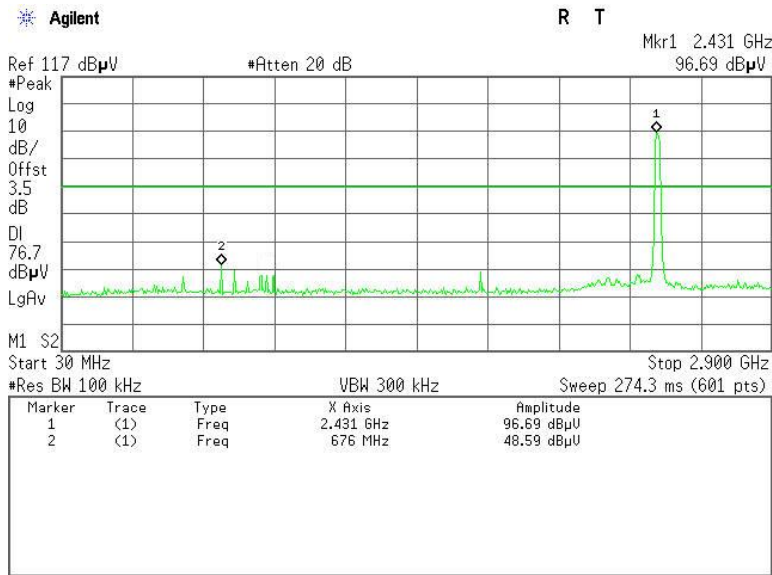

CH Mid (2.9GHz ~26.5GHz)

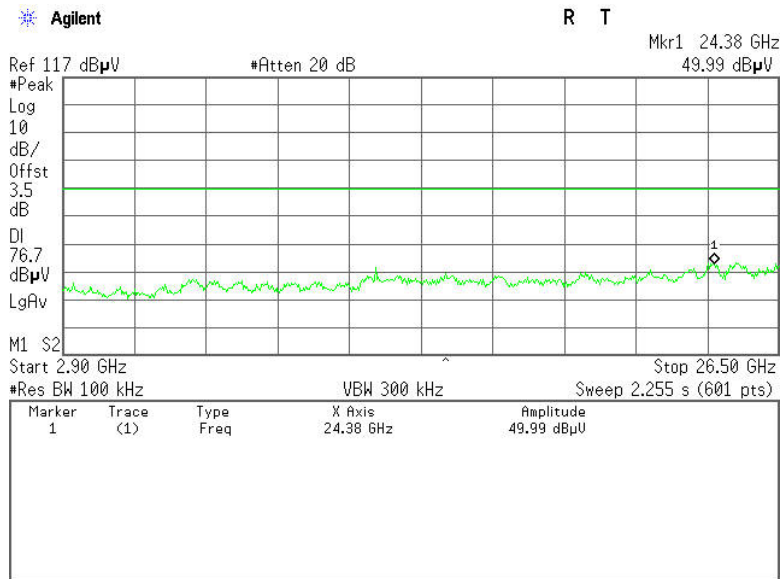



CH High (30MHz ~2.9GHz)

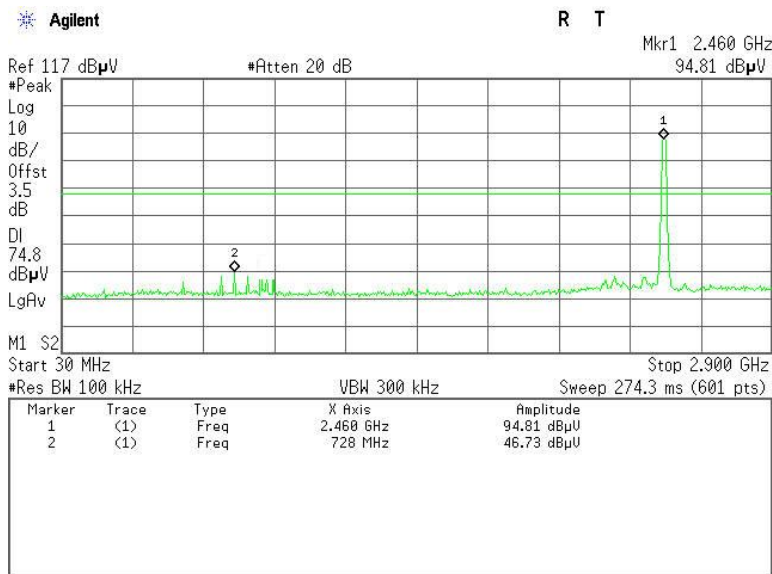

CH High (2.9GHz ~26.5GHz)

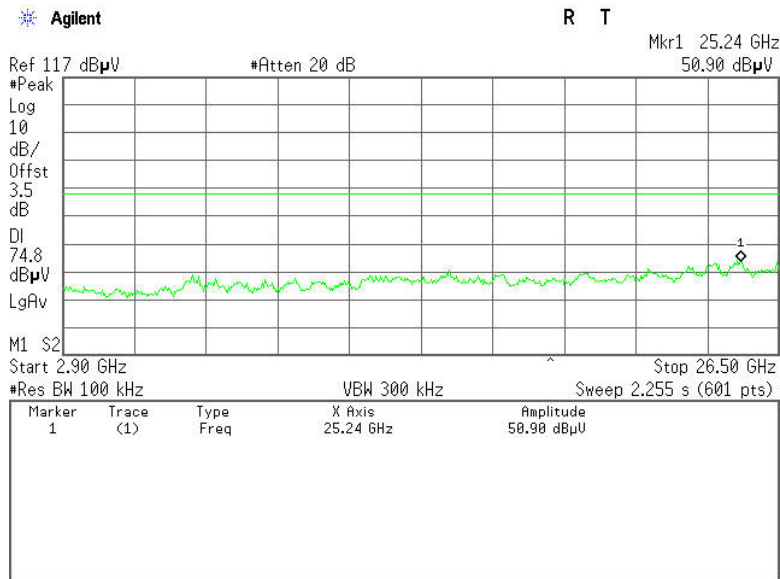



Test Plot
IEEE 802.11n HT20 MHz mode(Antenna 0)
CH Low (30MHz ~2.9GHz)

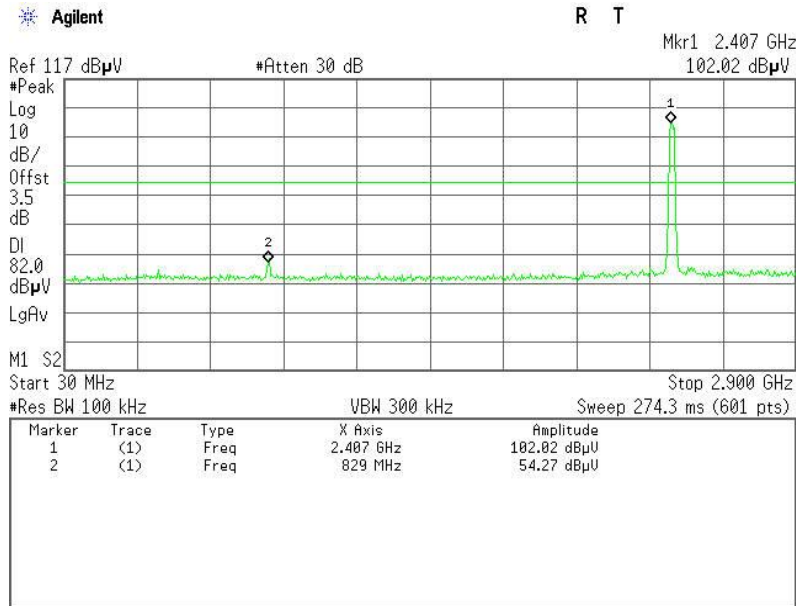

CH Low (2.9GHz ~26.5GHz)

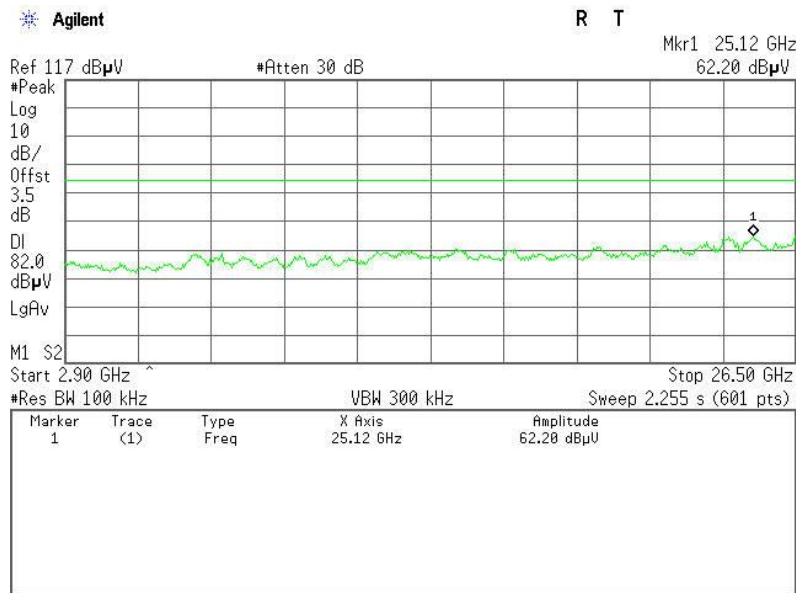



CH Mid (30MHz ~2.9GHz)

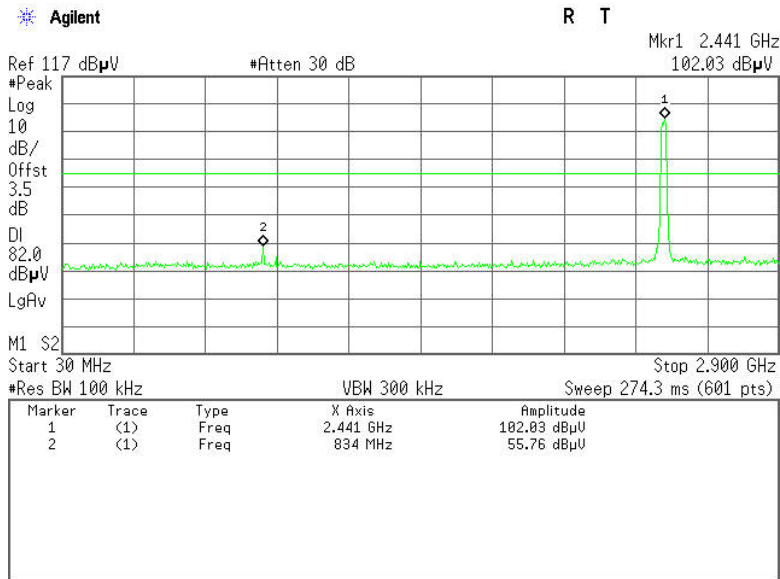

CH Mid (2.9GHz ~26.5GHz)

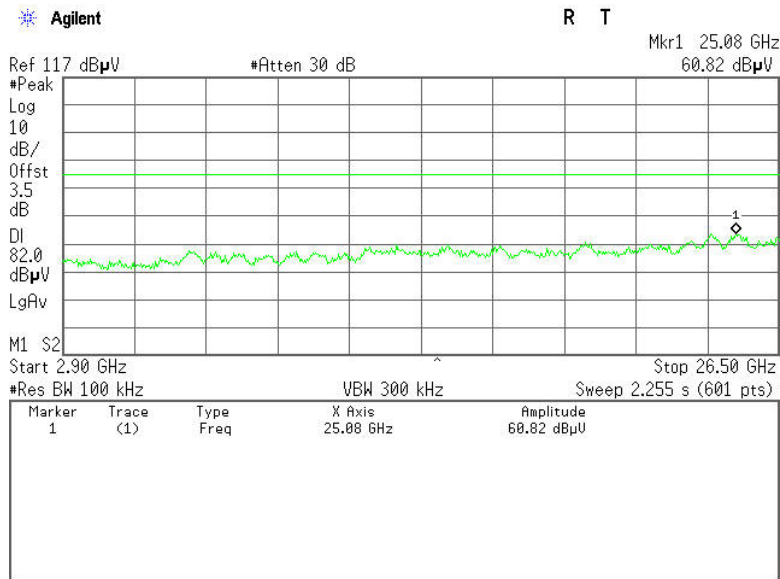



CH High (30MHz ~2.9GHz)

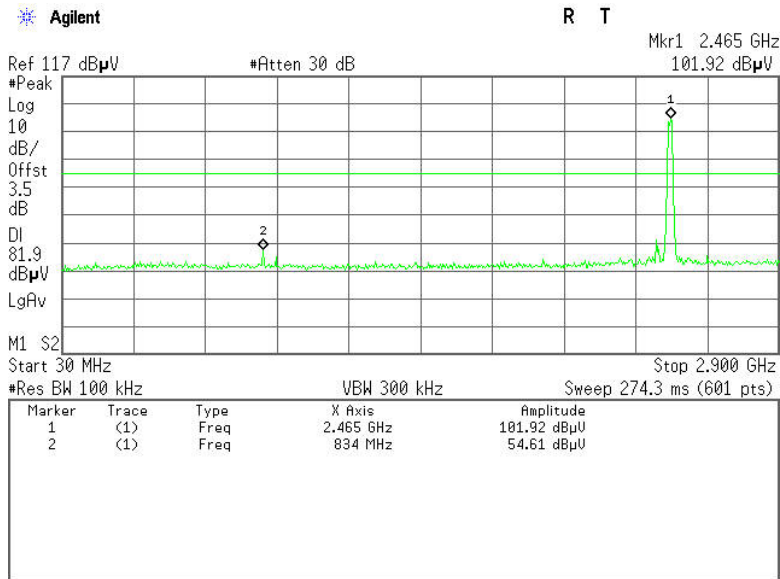

CH High (2.9GHz ~26.5GHz)

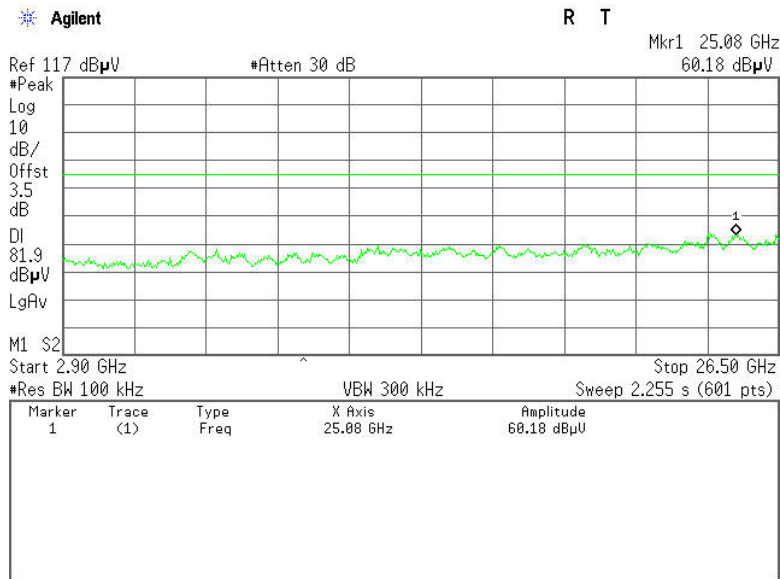



IEEE 802.11n HT20 MHz mode(Antenna 1)

CH Low (30MHz ~2.9GHz)

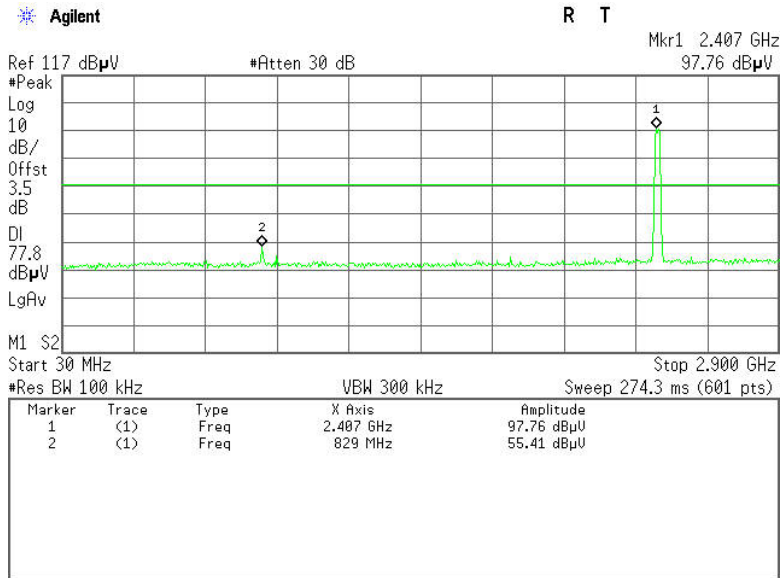

CH Low (2.9GHz ~26.5GHz)

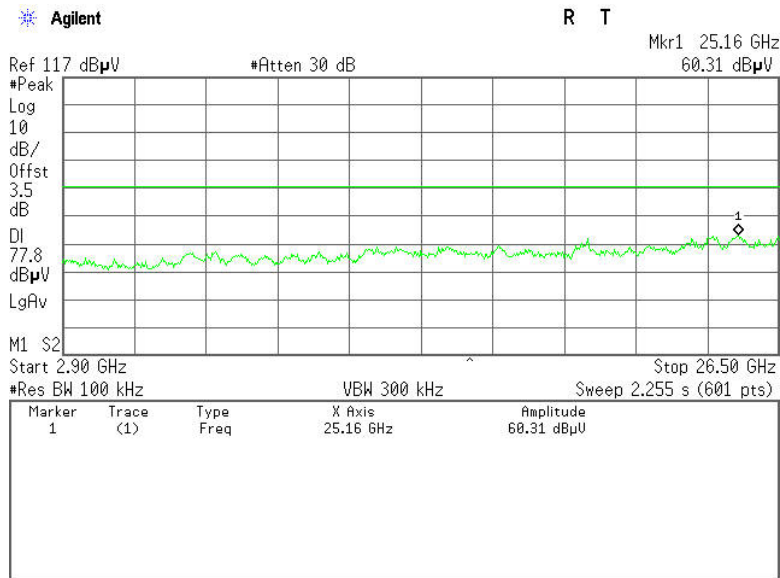



CH Mid (30MHz ~2.9GHz)

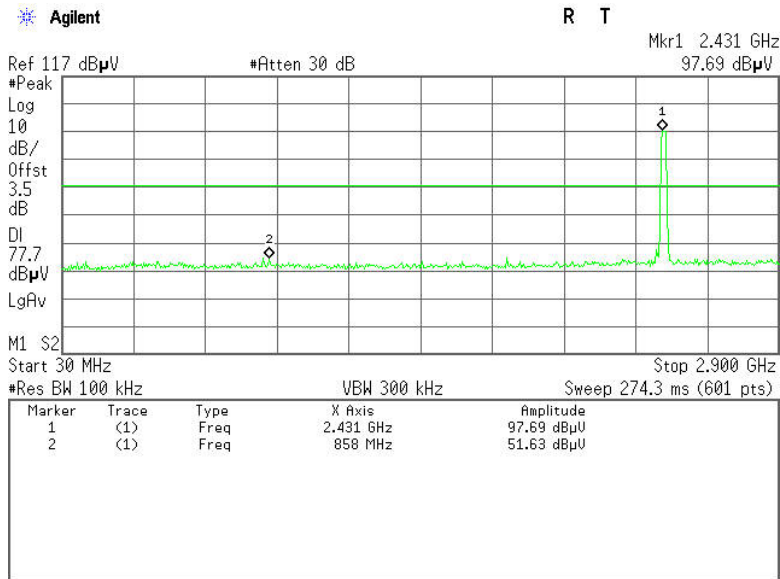

CH Mid (2.9GHz ~26.5GHz)

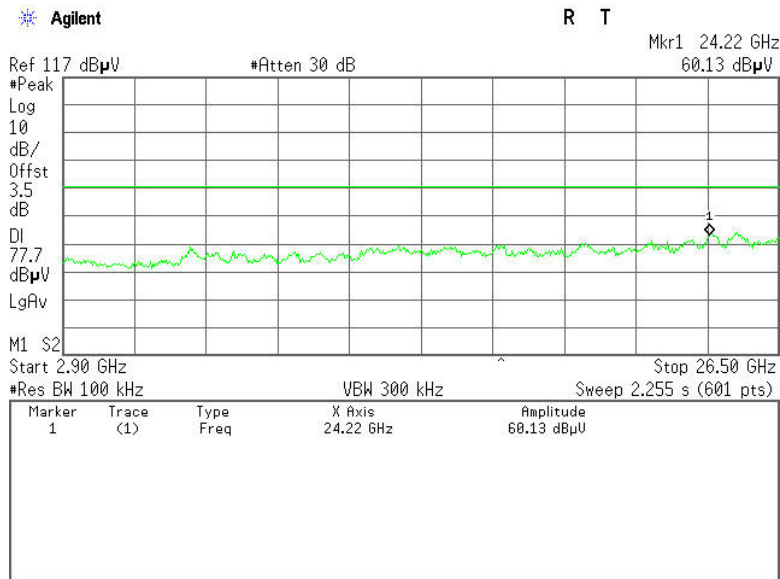



CH High (30MHz ~2.9GHz)

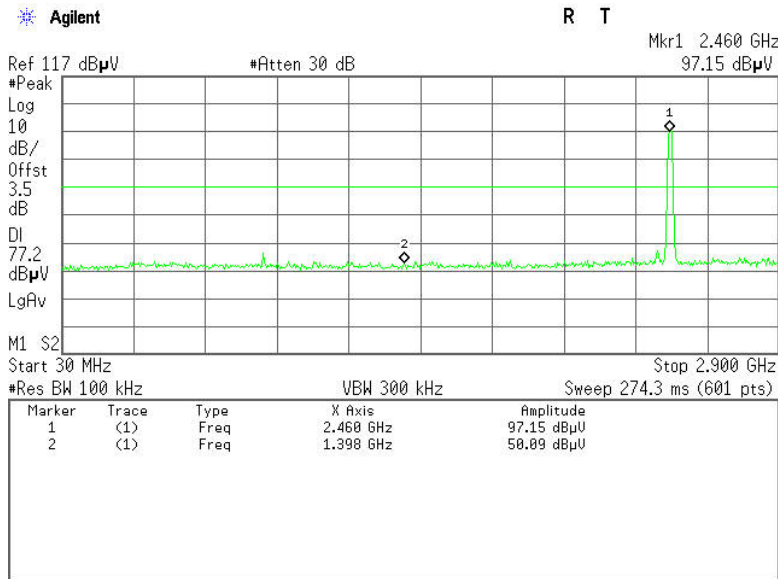

CH High (2.9GHz ~26.5GHz)

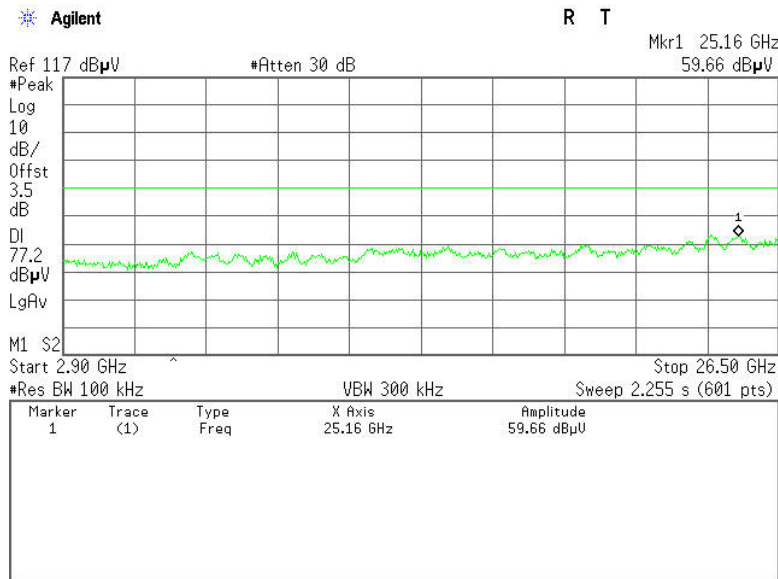



IEEE 802.11n HT40 MHz mode(Antenna 0)

CH Low (30MHz ~2.9GHz)

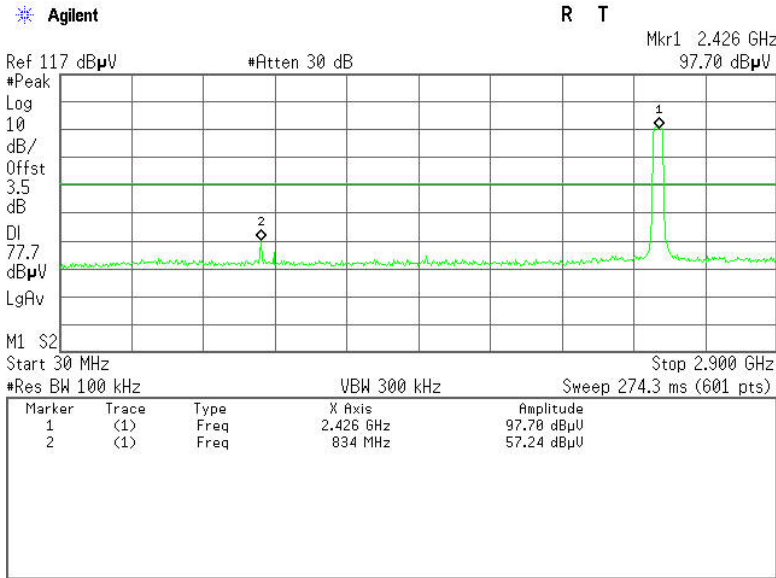

CH Low (2.9GHz ~26.5GHz)

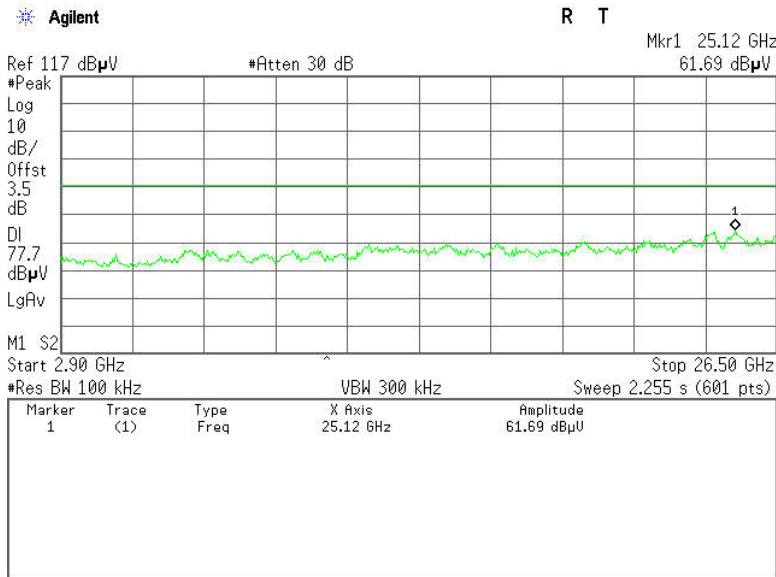



CH Mid (30MHz ~2.9GHz)

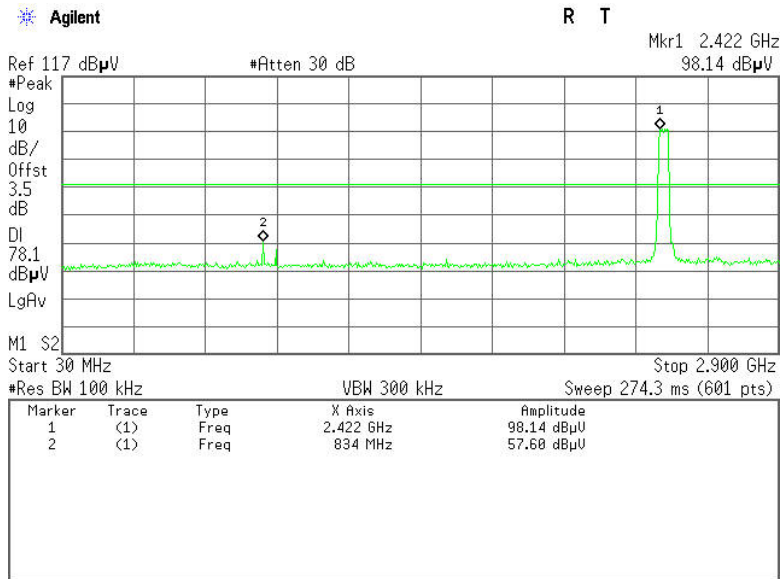

CH Mid (2.9GHz ~26.5GHz)

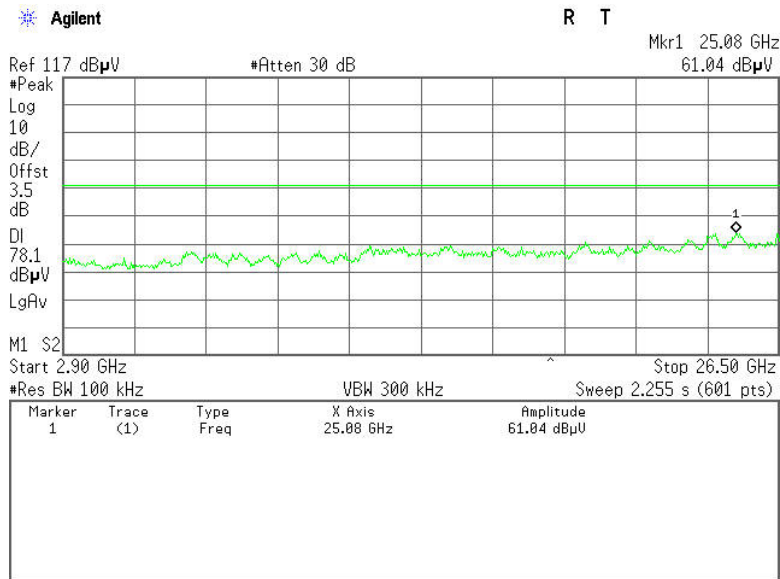



CH High (30MHz ~2.9GHz)

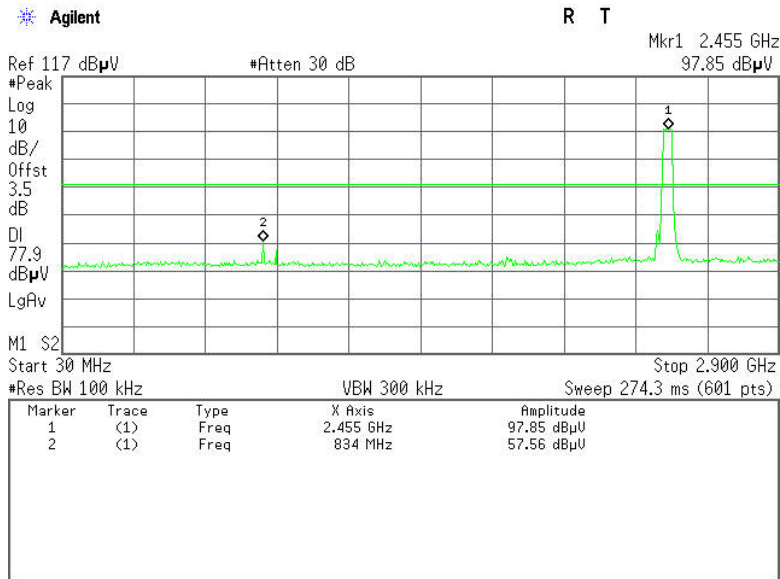

CH High (2.9GHz ~26.5GHz)

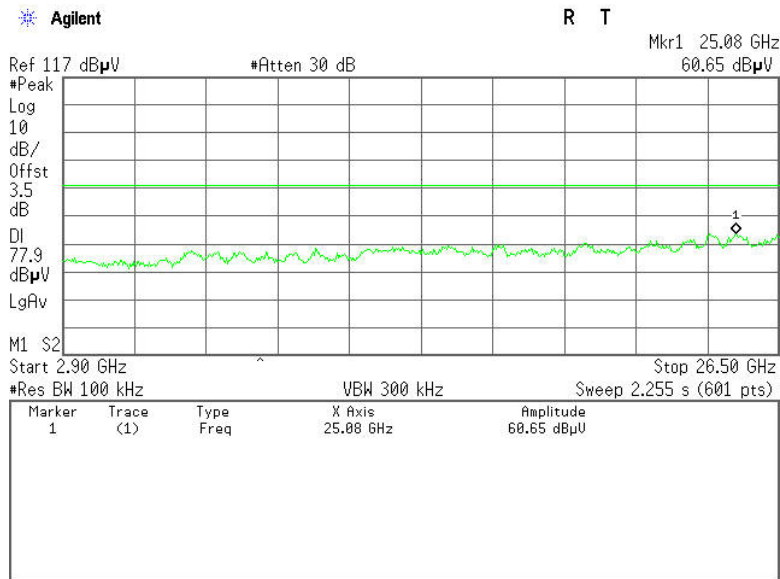



IEEE 802.11n HT40 MHz mode(Antenna 1)

CH Low (30MHz ~2.9GHz)

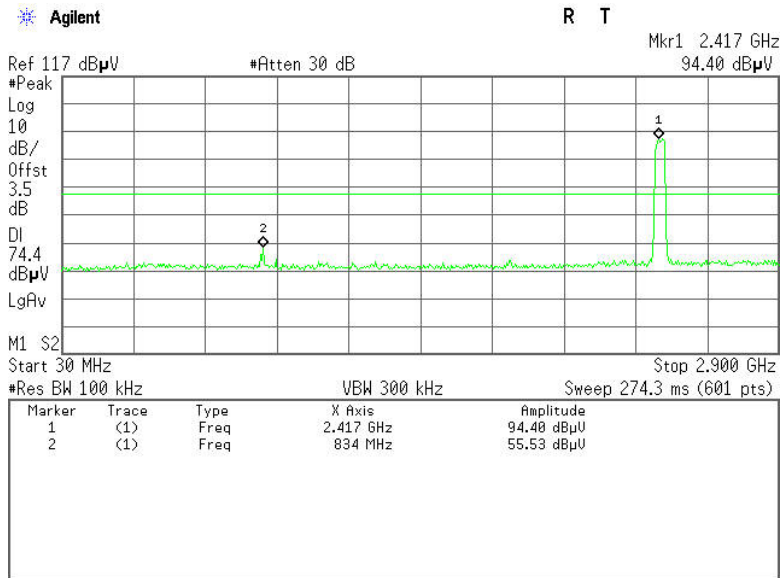

CH Low (2.9GHz ~26.5GHz)

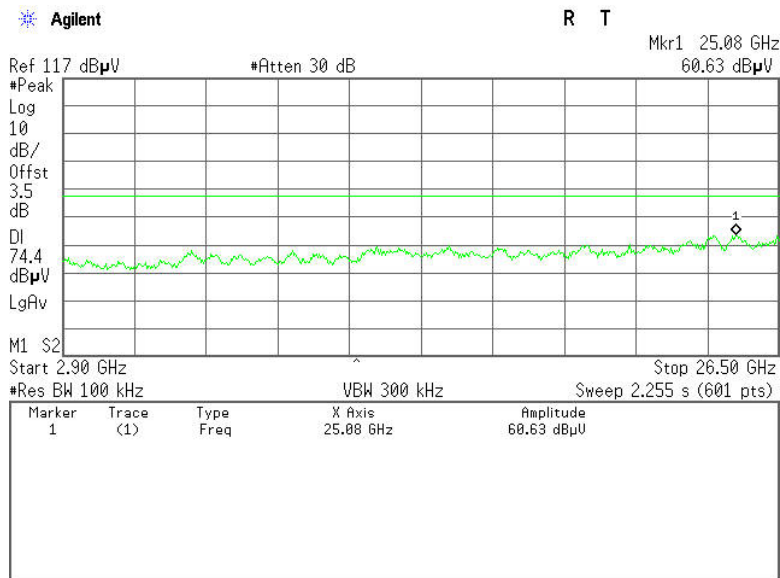



CH Mid (30MHz ~2.9GHz)

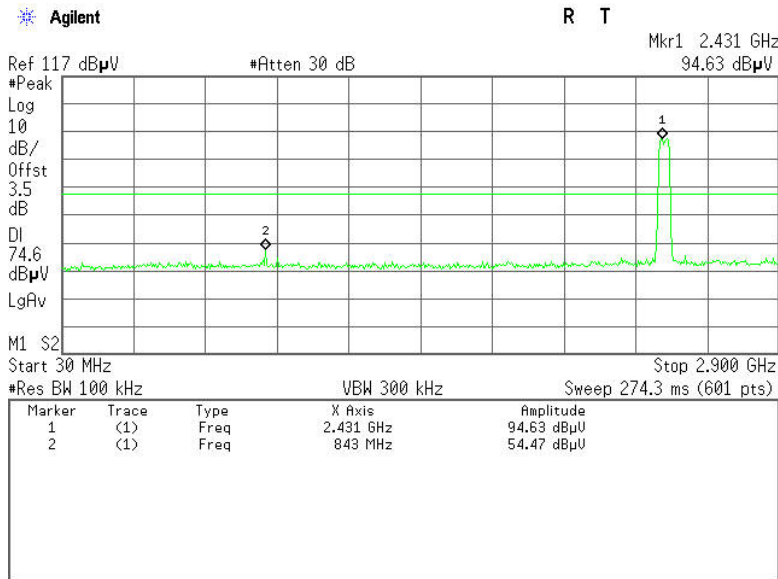

CH Mid (2.9GHz ~26.5GHz)

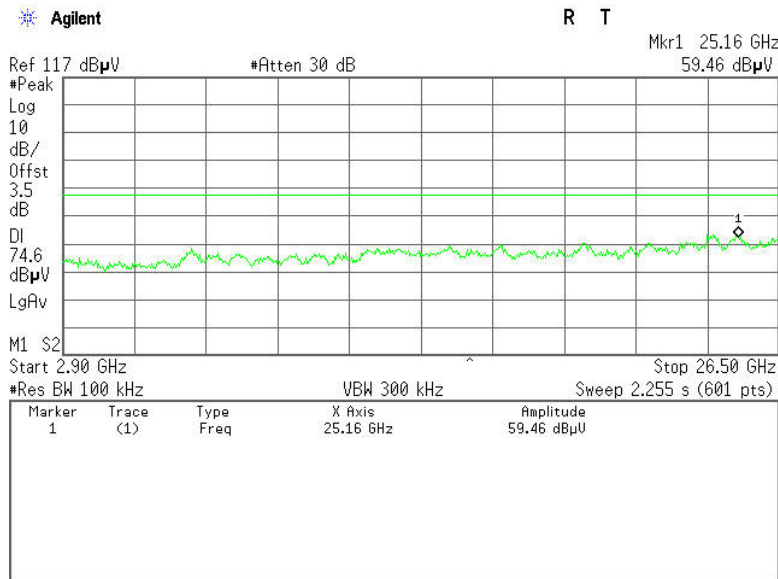



CH High (30MHz ~2.9GHz)

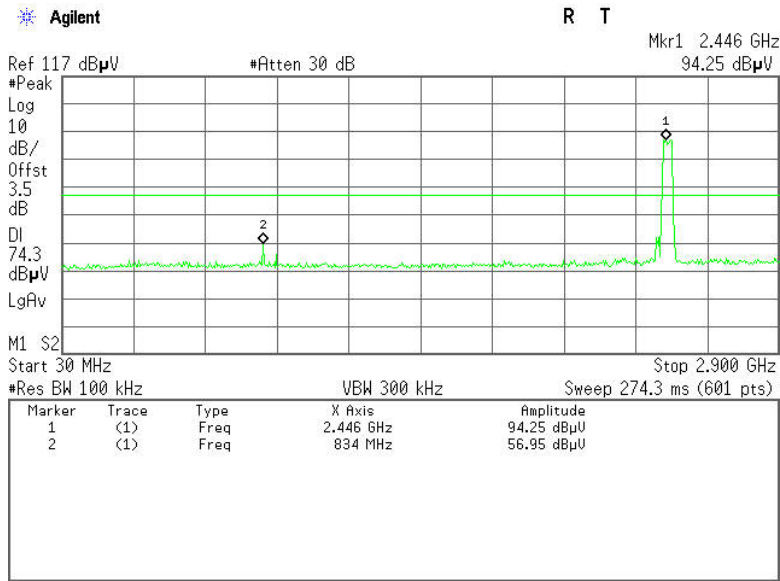

CH High (2.9GHz ~26.5GHz)

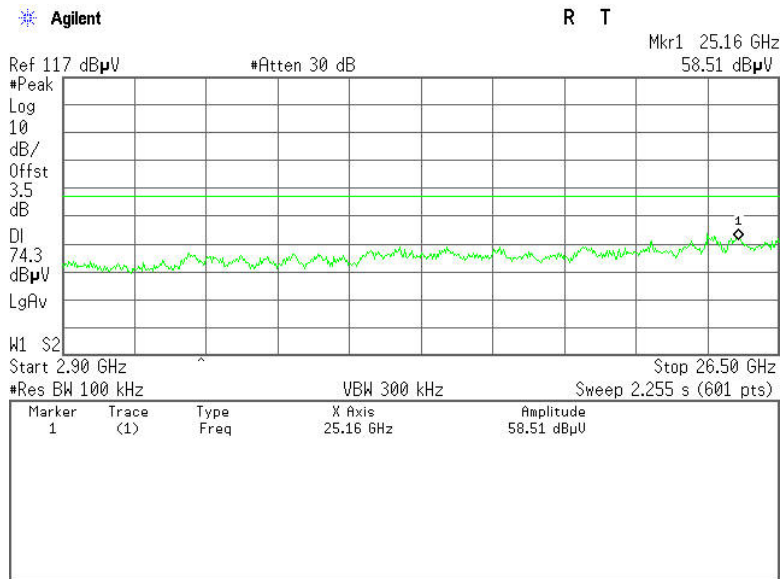



7.2.4.1. LIMITS OF RADIATED EMISSIONS MEASUREMENT

According to §15.209(a), except as provided elsewhere in this Subpart, the emissions from an intentional radiator shall not exceed the field strength levels specified in the following table:

Frequency (MHz)	Field Strength (mV/m)	Measurement Distance (m)
0.009-0.490	2400/F(kHz)	300
0.490-1.705	24000/F(kHz)	30
1.705-30.0	30	30
30-88	100*	3
88-216	150*	3
216-960	200*	3
Above 960	500	3

Remark: Except as provided in paragraph (g), fundamental emissions from intentional radiators operating under this Section shall not be located in the frequency bands 54-72 MHz, 76-88 MHz, 174-216 MHz or 470-806 MHz. However, operation within these frequency bands is permitted under other sections of this Part, e.g., Sections 15.231 and 15.241.

1. In the emission table above, the tighter limit applies at the band edges.

Frequency (MHz)	Field Strength (µV/m at 3-meter)	Field Strength (dBµV/m at 3-meter)
30-88	100	40
88-216	150	43.5
216-960	200	46
Above 960	500	54

NOTE:(1) The lower limit shall apply at the transition frequencies.
(2) Emission level (dBuV/m) = 20 log Emission level (uV/m).



7.2.4.2. TEST INSTRUMENTS

Radiated Emission Test Site 966(2)					
Name of Equipment	Manufacturer	Model Number	Serial Number	Last Calibration	Due Calibration
PSA Series Spectrum Analyzer	Agilent	E4446A	US44300399	03/19/2012	03/19/2013
ESCI EMI TEST RECEIVER.ESCI	ROHDE&SCHWARZ	ESCI	100783	03/17/2012	03/17/2013
Amplifier	MITEQ	AM-1604-3000	1123808	03/18/2012	03/18/2013
Turn Table	EMCO	2081-1.21	N/A	N.C.R	N.C.R
Controller	CT	N/A	N/A	N.C.R	N.C.R
High Noise Amplifier	Agilent	8449B	3008A01838	03/18/2012	03/18/2013
Bilog Antenna	SCHAFFNER	CBL6143	5082	03/17/2012	03/17/2013
Horn Antenna	SCHWARZBECK	BBHA9120	D286	03/17/2012	03/17/2013
Loop Antenna	A、 R、 A	PLA-1030/B	1029	03/23/2012	03/23/2013
Temp. / Humidity Meter	VICTOR	VC230	N/A	03/19/2012	03/19/2013
Antenna Tower	SUNOL	TLT2	N/A	N.C.R	N.C.R
Test S/W	FARAD	LZ-RF / CCS-SZ-3A2			

- NOTE:** 1. The calibration interval of the above test instruments is 12 months and the calibrations are traceable to NML/ROC and NIST/USA.
 2. The FCC Site Registration number is 101879.
 3. N.C.R = No Calibration Required.

7.2.4.3. TEST PROCEDURE (please refer to measurement standard)

- The EUT is placed on a turntable, which is 0.8m above ground plane.
- The turntable shall be rotated for 360 degrees to determine the position of maximum emission level.
- EUT is set 3m away from the receiving antenna, which is varied from 1m to 4m to find out the highest emissions.
- Maximum procedure was performed on the six highest emissions to ensure EUT compliance.
- And also, each emission was to be maximized by changing the polarization of receiving antenna both horizontal and vertical.
- Set the spectrum analyzer in the following setting as:
 Below 1GHz:
 RBW=100kHz / VBW=300kHz / Sweep=AUTO
 Above 1GHz:
 (a) PEAK: RBW=1MHz,VBW=3MHz / Sweep=AUTO
 (b) AVERAGE: RBW=1MHz / VBW=10Hz / Sweep=AUTO
- Repeat above procedures until the measurements for all frequencies are complete.



7.2.4.4. TEST SETUP

Below 30MHz

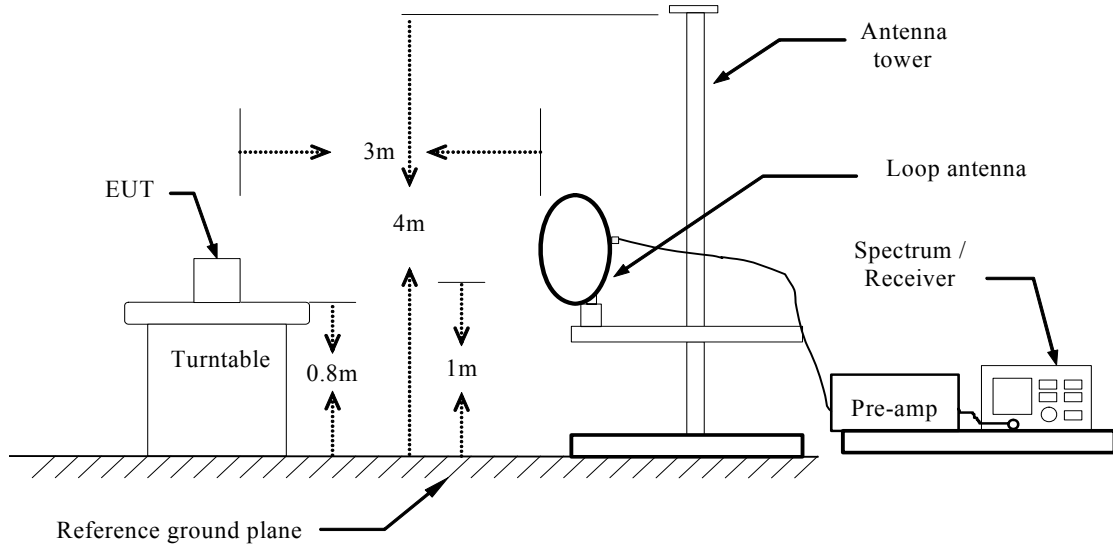

Below 1 GHz

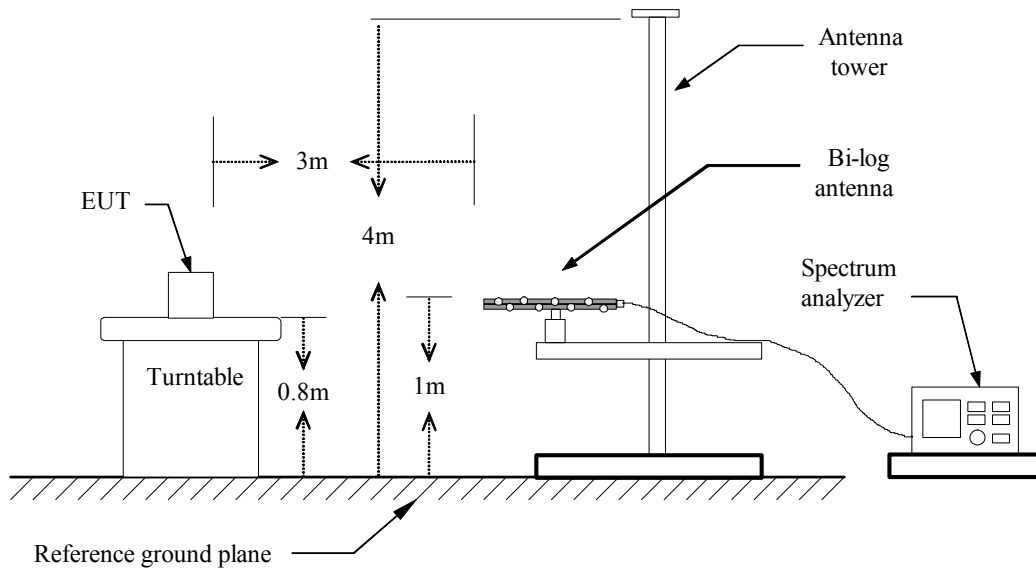



Above 1 GHz

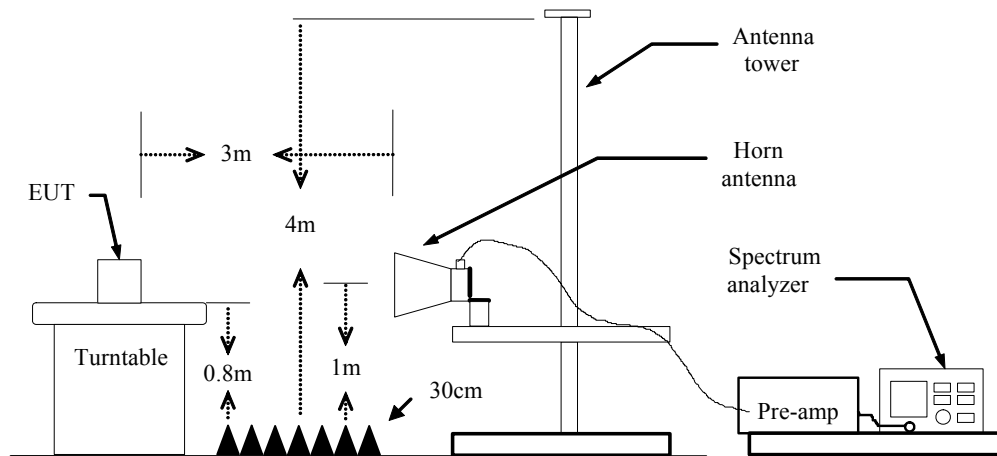

For the actual test configuration, please refer to the related item – Photographs of the Test Configuration.



7.2.4.5. DATA SAPLE

Below 1GHz

Frequency (MHz)	Reading (dBuV)	Correct Factor (dB/m)	Result (dBuV/m)	Limit (dBuV/m)	Margin (dB)	Antenna Pole (V/H)	Remark
XXX.XXXX	36.37	-12.20	24.17	40.00	-15.83	V	QP

- Frequency (MHz) = Emission frequency in MHz
- Reading (dBuV) = Uncorrected Analyzer / Receiver reading
- Correct Factor (dB/m) = Antenna factor + Cable loss – Amplifier gain
- Result (dBuV/m) = Reading (dBuV) + Corr. Factor (dB/m)
- Limit (dBuV/m) = Limit stated in standard
- Margin (dB) = Result (dBuV/m) – Limit (dBuV/m)
- Q.P. = Quasi-peak Reading

Above 1GHz

Frequency (MHz)	Reading (dBuV)	Correction Factor (dB/m)	Result (dBuV/m)	Limit (dBuV/m)	Margin (dB)	Antenna Pole (V/H)	Remark
XXXX.XXXX	62.09	-11.42	50.67	74.00	-23.33	V	Peak
XXXX.XXXX	49.78	-11.42	38.36	54.00	-15.64	V	AVG

- Frequency (MHz) = Emission frequency in MHz
- Reading (dBuV) = Uncorrected Analyzer / Receiver reading
- Correction Factor (dB/m) = Antenna factor + Cable loss – Amplifier gain
- Result (dBuV/m) = Reading (dBuV) + Corr. Factor (dB/m)
- Limit (dBuV/m) = Limit stated in standard
- Margin (dB) = Result (dBuV/m) – Limit (dBuV/m)
- Peak = Peak Reading
- AVG = Average Reading

Calculation Formula

Margin (dB) = Result (dBuV/m) – Limits (dBuV/m)
 Result (dBuV/m) = Reading (dBuV) + Correction Factor



7.2.4.6. TEST RESULTS

Below 1 GHz

Operation Mode: TX Test Date: January 30, 2013
Temperature: 24°C Tested by: Leevin Li
Humidity: 52% RH Polarity: Ver. / Hor.

(The chart below shows the highest readings taken from the final data.)

Table with 8 columns: Frequency (MHz), Reading (dBuV), Correct Factor (dB/m), Result (dBuV/m), Limit (dBuV/m), Margin (dB), Antenna Pole (V/H), Remark. It contains two sets of data rows for various frequencies.

**Remark: No emission found between lowest internal used/generated frequency to 30MHz.

Notes:

- 1. Radiated emissions measured in frequency range from 9kHz to 1GHz were made with an instrument using Quasi-peak detector mode.
2. Data of measurement within this frequency range shown " --- " in the table above means the reading of emissions are attenuated more than 20dB below the permissible limits or the field strength is too small to be measured.
3. The IF bandwidth of Receiver between 30MHz to 1GHz was 120kHz.
4. Frequency (MHz) = Emission frequency in MHz
Reading (dBuV/m) = Receiver reading
Correction Factor (dB) = Antenna factor + Cable loss - Amplifier gain
Limit (dBuV/m) = Limit stated in standard
Margin (dB) = Measured (dBuV/m) - Limits (dBuV/m)
Antenna Pole (H/V) = Current carrying line of reading



Above 1 GHz

Antenna1

Operation Mode: TX / IEEE 802.11b / CH Low

Test Date: January 30, 2013

Temperature: 24°C

Tested by: Leevin Li

Humidity: 52% RH

Polarity: Ver. / Hor.

Frequency (MHz)	Reading (dBuV)	Correction Factor (dB/m)	Result (dBuV/m)	Limit (dBuV/m)	Margin (dB)	Antenna Pole (V/H)	Remark
1090.0000	51.55	-9.61	41.94	74.00	-32.06	V	Peak
1465.0000	50.89	-8.11	42.78	74.00	-31.22	V	Peak
3040.0000	47.19	-4.21	42.98	74.00	-31.02	V	Peak
3805.0000	45.62	-2.49	43.13	74.00	-30.87	V	Peak
4825.0000	54.81	0.52	55.33	74.00	-18.67	V	Peak
4825.0000	50.67	0.52	51.19	54.00	-2.81	V	AVG
6130.0000	45.54	3.48	49.02	74.00	-24.98	V	Peak
1090.0000	49.85	-9.61	40.24	74.00	-33.76	H	Peak
3310.0000	46.80	-4.04	42.76	74.00	-31.24	H	Peak
4525.0000	45.52	-0.59	44.93	74.00	-29.07	H	Peak
4825.0000	47.65	0.52	48.17	74.00	-25.83	H	Peak
6100.0000	45.14	3.39	48.53	74.00	-25.47	H	Peak
6805.0000	44.92	5.52	50.44	74.00	-23.56	H	Peak

REMARKS:

1. Measuring frequencies from 1 GHz to the 10th harmonic of highest fundamental frequency.
2. Radiated emissions measured in frequency above 1000MHz were made with an instrument using peak/average detector mode.
3. Average test would be performed if the peak result were greater than the average limit or as required by the applicant.
4. Data of measurement within this frequency range shown " --- " in the table above means the reading of emissions are attenuated more than 20dB below the permissible limits or the field strength is too small to be measured.
5. Measurements above show only up to 6 maximum emissions noted, or would be lesser, with " N/A " remark, if no specific emissions from the EUT are recorded (ie: margin>20dB from the applicable limit) and considered that's already beyond the background noise floor.
6. Margin (dB) = Remark result (dBuV/m) – Average limit (dBuV/m).



Operation Mode: TX / IEEE 802.11b / CH Mid
Temperature: 24°C
Humidity: 52% RH

Test Date: January 30, 2013
Tested by: Leevin Li
Polarity: Ver. / Hor.

Table with 8 columns: Frequency (MHz), Reading (dBuV), Correction Factor (dB/m), Result (dBuV/m), Limit (dBuV/m), Margin (dB), Antenna Pole (V/H), Remark. It contains two sections of data rows.

REMARKS:

- 1. Measuring frequencies from 1 GHz to the 10th harmonic of highest fundamental frequency.
2. Radiated emissions measured in frequency above 1000MHz were made with an instrument using peak/average detector mode.
3. Average test would be performed if the peak result were greater than the average limit or as required by the applicant.
4. Data of measurement within this frequency range shown " --- " in the table above means the reading of emissions are attenuated more than 20dB below the permissible limits or the field strength is too small to be measured.
5. Measurements above show only up to 6 maximum emissions noted, or would be lesser, with " N/A " remark, if no specific emissions from the EUT are recorded (ie: margin>20dB from the applicable limit) and considered that's already beyond the background noise floor.
6. Margin (dB) = Remark result (dBuV/m) – Average limit (dBuV/m).



Operation Mode: TX / IEEE 802.11b / CH High **Test Date:** January 30, 2013
Temperature: 24°C **Tested by:** Leevin Li
Humidity: 52% RH **Polarity:** Ver. / Hor.

Frequency (MHz)	Reading (dBuV)	Correction Factor (dB/m)	Result (dBuV/m)	Limit (dBuV/m)	Margin (dB)	Antenna Pole (V/H)	Remark
1300.0000	49.86	-8.28	41.58	74.00	-32.42	V	Peak
1495.0000	51.22	-8.23	42.99	74.00	-31.01	V	Peak
1660.0000	52.78	-8.91	43.87	74.00	-30.13	V	Peak
3505.0000	45.83	-3.48	42.35	74.00	-31.65	V	Peak
4255.0000	45.73	-1.37	44.36	74.00	-29.64	V	Peak
4930.0000	54.91	1.00	55.91	74.00	-18.09	V	Peak
4930.0000	50.95	1.00	51.95	54.00	-2.05	V	AVG
1660.0000	52.33	-8.91	43.42	74.00	-30.58	H	Peak
3235.0000	47.28	-4.07	43.21	74.00	-30.79	H	Peak
4300.0000	45.48	-1.20	44.28	74.00	-29.72	H	Peak
4930.0000	50.72	1.00	51.72	74.00	-22.28	H	Peak
5815.0000	45.05	2.80	47.85	74.00	-26.15	H	Peak
6940.0000	45.69	6.04	51.73	74.00	-22.27	H	Peak

REMARKS:

1. Measuring frequencies from 1 GHz to the 10th harmonic of highest fundamental frequency.
2. Radiated emissions measured in frequency above 1000MHz were made with an instrument using peak/average detector mode.
3. Average test would be performed if the peak result were greater than the average limit or as required by the applicant.
4. Data of measurement within this frequency range shown " --- " in the table above means the reading of emissions are attenuated more than 20dB below the permissible limits or the field strength is too small to be measured.
5. Measurements above show only up to 6 maximum emissions noted, or would be lesser, with " N/A " remark, if no specific emissions from the EUT are recorded (ie: margin>20dB from the applicable limit) and considered that's already beyond the background noise floor.
6. Margin (dB) = Remark result (dBuV/m) – Average limit (dBuV/m).



Antenna1

Operation Mode: TX / IEEE 802.11g / CH Low

Test Date: January 30, 2013

Temperature: 24°C

Tested by: Leevin Li

Humidity: 52% RH

Polarity: Ver. / Hor.

Frequency (MHz)	Reading (dBuV)	Correction Factor (dB/m)	Result (dBuV/m)	Limit (dBuV/m)	Margin (dB)	Antenna Pole (V/H)	Remark
1090.0000	51.93	-9.61	42.32	74.00	-31.68	V	Peak
1570.0000	51.65	-8.55	43.10	74.00	-30.90	V	Peak
3670.0000	45.72	-2.83	42.89	74.00	-31.11	V	Peak
4480.0000	45.05	-0.68	44.37	74.00	-29.63	V	Peak
4840.0000	47.01	0.59	47.60	74.00	-26.40	V	Peak
5755.0000	44.87	2.59	47.46	74.00	-26.54	V	Peak
1195.0000	51.55	-8.77	42.78	74.00	-31.22	H	Peak
3400.0000	47.01	-4.00	43.01	74.00	-30.99	H	Peak
3745.0000	46.39	-2.63	43.76	74.00	-30.24	H	Peak
4525.0000	45.64	-0.59	45.05	74.00	-28.95	H	Peak
4825.0000	45.29	0.52	45.81	74.00	-28.19	H	Peak
6100.0000	44.93	3.39	48.32	74.00	-25.68	H	Peak

REMARKS:

1. Measuring frequencies from 1 GHz to the 10th harmonic of highest fundamental frequency.
2. Radiated emissions measured in frequency above 1000MHz were made with an instrument using peak/average detector mode.
3. Average test would be performed if the peak result were greater than the average limit or as required by the applicant.
4. Data of measurement within this frequency range shown " --- " in the table above means the reading of emissions are attenuated more than 20dB below the permissible limits or the field strength is too small to be measured.
5. Measurements above show only up to 6 maximum emissions noted, or would be lesser, with " N/A " remark, if no specific emissions from the EUT are recorded (ie: margin>20dB from the applicable limit) and considered that's already beyond the background noise floor.
6. Margin (dB) = Remark result (dBuV/m) – Average limit (dBuV/m).



Operation Mode: TX / IEEE 802.11g / CH Mid

Test Date: January 30, 2013

Temperature: 24°C

Tested by: Leevin Li

Humidity: 52 % RH

Polarity: Ver. / Hor.

Frequency (MHz)	Reading (dBuV)	Correction Factor (dB/m)	Result (dBuV/m)	Limit (dBuV/m)	Margin (dB)	Antenna Pole (V/H)	Remark
1465.0000	52.28	-8.11	44.17	74.00	-29.83	V	Peak
2935.0000	47.38	-4.50	42.88	74.00	-31.12	V	Peak
3355.0000	46.23	-4.02	42.21	74.00	-31.79	V	Peak
4315.0000	45.61	-1.14	44.47	74.00	-29.53	V	Peak
4915.0000	45.84	0.93	46.77	74.00	-27.23	V	Peak
5095.0000	44.68	1.43	46.11	74.00	-27.89	V	Peak
1195.0000	51.49	-8.77	42.72	74.00	-31.28	H	Peak
3310.0000	47.09	-4.04	43.05	74.00	-30.95	H	Peak
3910.0000	46.95	-2.51	44.44	74.00	-29.56	H	Peak
4525.0000	44.89	-0.59	44.30	74.00	-29.70	H	Peak
5200.0000	45.25	1.55	46.80	74.00	-27.20	H	Peak
6550.0000	45.27	4.68	49.95	74.00	-24.05	H	Peak

REMARKS:

1. Measuring frequencies from 1 GHz to the 10th harmonic of highest fundamental frequency.
2. Radiated emissions measured in frequency above 1000MHz were made with an instrument using peak/average detector mode.
3. Average test would be performed if the peak result were greater than the average limit or as required by the applicant.
4. Data of measurement within this frequency range shown " --- " in the table above means the reading of emissions are attenuated more than 20dB below the permissible limits or the field strength is too small to be measured.
5. Measurements above show only up to 6 maximum emissions noted, or would be lesser, with " N/A " remark, if no specific emissions from the EUT are recorded (ie: margin>20dB from the applicable limit) and considered that's already beyond the background noise floor.
6. Margin (dB) = Remark result (dBuV/m) – Average limit (dBuV/m).



Operation Mode: TX / IEEE 802.11g / CH High
Temperature: 24°C
Humidity: 52 % RH

Test Date: January 30, 2013
Tested by: Leevin Li
Polarity: Ver. / Hor.

Table with 8 columns: Frequency (MHz), Reading (dBuV), Correction Factor (dB/m), Result (dBuV/m), Limit (dBuV/m), Margin (dB), Antenna Pole (V/H), Remark. It contains 14 rows of test data.

REMARKS:

- 1. Measuring frequencies from 1 GHz to the 10th harmonic of highest fundamental frequency.
2. Radiated emissions measured in frequency above 1000MHz were made with an instrument using peak/average detector mode.
3. Average test would be performed if the peak result were greater than the average limit or as required by the applicant.
4. Data of measurement within this frequency range shown " --- " in the table above means the reading of emissions are attenuated more than 20dB below the permissible limits or the field strength is too small to be measured.
5. Measurements above show only up to 6 maximum emissions noted, or would be lesser, with " N/A " remark, if no specific emissions from the EUT are recorded (ie: margin>20dB from the applicable limit) and considered that's already beyond the background noise floor.
6. Margin (dB) = Remark result (dBuV/m) – Average limit (dBuV/m).



Antenna0 + Antenna1

Operation Mode: TX / IEEE 802.11n HT20 MHz / CH Low **Test Date:** March 1, 2013

Temperature: 24°C

Tested by: Leevin Li

Humidity: 52% RH

Polarity: Ver. / Hor.

Frequency (MHz)	Reading (dBuV)	Correction Factor (dB/m)	Result (dBuV/m)	Limit (dBuV/m)	Margin (dB)	Antenna Pole (V/H)	Remark
1510.0000	54.08	-8.30	45.78	74.00	-28.22	V	Peak
3265.0000	46.72	-4.06	42.66	74.00	-31.34	V	Peak
3760.0000	46.48	-2.59	43.89	74.00	-30.11	V	Peak
4270.0000	45.97	-1.31	44.66	74.00	-29.34	V	Peak
4840.0000	45.39	0.59	45.98	74.00	-28.02	V	Peak
5365.0000	45.54	1.53	47.07	74.00	-26.93	V	Peak
1510.0000	54.02	-8.30	45.72	74.00	-28.28	H	Peak
3610.0000	46.93	-2.98	43.95	74.00	-30.05	H	Peak
4405.0000	45.90	-0.81	45.09	74.00	-28.91	H	Peak
4765.0000	46.47	0.26	46.73	74.00	-27.27	H	Peak
5560.0000	45.50	1.85	47.35	74.00	-26.65	H	Peak
6280.0000	45.46	3.92	49.38	74.00	-24.62	H	Peak

REMARKS:

1. Measuring frequencies from 1 GHz to the 10th harmonic of highest fundamental frequency.
2. Radiated emissions measured in frequency above 1000MHz were made with an instrument using peak/average detector mode.
3. Average test would be performed if the peak result were greater than the average limit or as required by the applicant.
4. Data of measurement within this frequency range shown " --- " in the table above means the reading of emissions are attenuated more than 20dB below the permissible limits or the field strength is too small to be measured.
5. Measurements above show only up to 6 maximum emissions noted, or would be lesser, with " N/A " remark, if no specific emissions from the EUT are recorded (ie: margin>20dB from the applicable limit) and considered that's already beyond the background noise floor.
6. Margin (dB) = Remark result (dBuV/m) – Average limit (dBuV/m).



Operation Mode: TX / IEEE 802.11n HT20 MHz / CH Mid **Test Date:** March 1, 2013
Temperature: 24°C **Tested by:** Leevin Li
Humidity: 52% RH **Polarity:** Ver. / Hor.

Frequency (MHz)	Reading (dBuV)	Correction Factor (dB/m)	Result (dBuV/m)	Limit (dBuV/m)	Margin (dB)	Antenna Pole (V/H)	Remark
1660.0000	56.40	-8.91	47.49	74.00	-26.51	V	Peak
3715.0000	46.41	-2.71	43.70	74.00	-30.30	V	Peak
4225.0000	46.51	-1.48	45.03	74.00	-28.97	V	Peak
4900.0000	45.61	0.86	46.47	74.00	-27.53	V	Peak
5605.0000	45.25	1.95	47.20	74.00	-26.80	V	Peak
6055.0000	45.61	3.25	48.86	74.00	-25.14	V	Peak
1195.0000	50.95	-8.77	42.18	74.00	-31.82	H	Peak
3865.0000	46.39	-2.50	43.89	74.00	-30.11	H	Peak
4540.0000	45.39	-0.57	44.82	74.00	-29.18	H	Peak
5305.0000	45.31	1.53	46.84	74.00	-27.16	H	Peak
5920.0000	45.54	2.97	48.51	74.00	-25.49	H	Peak
6625.0000	44.83	4.91	49.74	74.00	-24.26	H	Peak

REMARKS:

1. Measuring frequencies from 1 GHz to the 10th harmonic of highest fundamental frequency.
2. Radiated emissions measured in frequency above 1000MHz were made with an instrument using peak/average detector mode.
3. Average test would be performed if the peak result were greater than the average limit or as required by the applicant.
4. Data of measurement within this frequency range shown " --- " in the table above means the reading of emissions are attenuated more than 20dB below the permissible limits or the field strength is too small to be measured.
5. Measurements above show only up to 6 maximum emissions noted, or would be lesser, with " N/A " remark, if no specific emissions from the EUT are recorded (ie: margin>20dB from the applicable limit) and considered that's already beyond the background noise floor.
6. Margin (dB) = Remark result (dBuV/m) – Average limit (dBuV/m).



Operation Mode: TX / IEEE 802.11n HT20 MHz / CH High Test Date: March 1, 2013

Temperature: 24°C Tested by: Leevin Li

Humidity: 52% RH Polarity: Ver. / Hor.

Frequency (MHz)	Reading (dBuV)	Correction Factor (dB/m)	Result (dBuV/m)	Limit (dBuV/m)	Margin (dB)	Antenna Pole (V/H)	Remark
1465.0000	51.93	-8.11	43.82	74.00	-30.18	V	Peak
3280.0000	47.10	-4.05	43.05	74.00	-30.95	V	Peak
3835.0000	45.83	-2.50	43.33	74.00	-30.67	V	Peak
4525.0000	45.33	-0.59	44.74	74.00	-29.26	V	Peak
4990.0000	45.90	1.27	47.17	74.00	-26.83	V	Peak
5950.0000	45.19	3.01	48.20	74.00	-25.80	V	Peak
1660.0000	55.51	-8.91	46.60	74.00	-27.40	H	Peak
3190.0000	47.18	-4.10	43.08	74.00	-30.92	H	Peak
3835.0000	45.76	-2.50	43.26	74.00	-30.74	H	Peak
4960.0000	45.65	1.14	46.79	74.00	-27.21	H	Peak
6010.0000	45.32	3.12	48.44	74.00	-25.56	H	Peak
6415.0000	45.37	4.30	49.67	74.00	-24.33	H	Peak

REMARKS:

1. Measuring frequencies from 1 GHz to the 10th harmonic of highest fundamental frequency.
2. Radiated emissions measured in frequency above 1000MHz were made with an instrument using peak/average detector mode.
3. Average test would be performed if the peak result were greater than the average limit or as required by the applicant.
4. Data of measurement within this frequency range shown " --- " in the table above means the reading of emissions are attenuated more than 20dB below the permissible limits or the field strength is too small to be measured.
5. Measurements above show only up to 6 maximum emissions noted, or would be lesser, with " N/A " remark, if no specific emissions from the EUT are recorded (ie: margin>20dB from the applicable limit) and considered that's already beyond the background noise floor.
6. Margin (dB) = Remark result (dBuV/m) – Average limit (dBuV/m).



Antenna0 + Antenna1

Operation Mode: TX / IEEE 802.11n HT40 MHz / CH Low

Test Date: March 1, 2013

Temperature: 24°C

Tested by: Leevin Li

Humidity: 52% RH

Polarity: Ver. / Hor.

Frequency (MHz)	Reading (dBuV)	Correction Factor (dB/m)	Result (dBuV/m)	Limit (dBuV/m)	Margin (dB)	Antenna Pole (V/H)	Remark
1465.0000	53.80	-8.11	45.69	74.00	-28.31	V	Peak
3760.0000	45.56	-2.59	42.97	74.00	-31.03	V	Peak
4270.0000	45.70	-1.31	44.39	74.00	-29.61	V	Peak
4825.0000	45.56	0.52	46.08	74.00	-27.92	V	Peak
5830.0000	45.51	2.83	48.34	74.00	-25.66	V	Peak
6490.0000	45.95	4.51	50.46	74.00	-23.54	V	Peak
1510.0000	52.23	-8.30	43.93	74.00	-30.07	H	Peak
3805.0000	46.27	-2.49	43.78	74.00	-30.22	H	Peak
4840.0000	44.50	0.59	45.09	74.00	-28.91	H	Peak
5245.0000	45.63	1.54	47.17	74.00	-26.83	H	Peak
5890.0000	45.43	2.92	48.35	74.00	-25.65	H	Peak
6310.0000	44.68	4.01	48.69	74.00	-25.31	H	Peak

REMARKS:

1. Measuring frequencies from 1 GHz to the 10th harmonic of highest fundamental frequency.
2. Radiated emissions measured in frequency above 1000MHz were made with an instrument using peak/average detector mode.
3. Average test would be performed if the peak result were greater than the average limit or as required by the applicant.
4. Data of measurement within this frequency range shown " --- " in the table above means the reading of emissions are attenuated more than 20dB below the permissible limits or the field strength is too small to be measured.
5. Measurements above show only up to 6 maximum emissions noted, or would be lesser, with " N/A " remark, if no specific emissions from the EUT are recorded (ie: margin>20dB from the applicable limit) and considered that's already beyond the background noise floor.
6. Margin (dB) = Remark result (dBuV/m) – Average limit (dBuV/m).



Operation Mode: TX / IEEE 802.11n HT40 MHz / CH Mid **Test Date:** March 1, 2013
Temperature: 24°C **Tested by:** Leevin Li
Humidity: 52% RH **Polarity:** Ver. / Hor.

Frequency (MHz)	Reading (dBuV)	Correction Factor (dB/m)	Result (dBuV/m)	Limit (dBuV/m)	Margin (dB)	Antenna Pole (V/H)	Remark
1465.0000	55.22	-8.11	47.11	74.00	-26.89	V	Peak
3235.0000	47.03	-4.07	42.96	74.00	-31.04	V	Peak
3790.0000	46.80	-2.52	44.28	74.00	-29.72	V	Peak
4240.0000	45.61	-1.43	44.18	74.00	-29.82	V	Peak
5050.0000	45.08	1.38	46.46	74.00	-27.54	V	Peak
6025.0000	44.61	3.16	47.77	74.00	-26.23	V	Peak
1465.0000	51.08	-8.11	42.97	74.00	-31.03	H	Peak
3835.0000	46.72	-2.50	44.22	74.00	-29.78	H	Peak
4480.0000	46.07	-0.68	45.39	74.00	-28.61	H	Peak
5185.0000	46.37	1.53	47.90	74.00	-26.10	H	Peak
5800.0000	45.10	2.78	47.88	74.00	-26.12	H	Peak
6175.0000	45.44	3.61	49.05	74.00	-24.95	H	Peak

REMARKS:

1. Measuring frequencies from 1 GHz to the 10th harmonic of highest fundamental frequency.
2. Radiated emissions measured in frequency above 1000MHz were made with an instrument using peak/average detector mode.
3. Average test would be performed if the peak result were greater than the average limit or as required by the applicant.
4. Data of measurement within this frequency range shown " --- " in the table above means the reading of emissions are attenuated more than 20dB below the permissible limits or the field strength is too small to be measured.
5. Measurements above show only up to 6 maximum emissions noted, or would be lesser, with " N/A " remark, if no specific emissions from the EUT are recorded (ie: margin>20dB from the applicable limit) and considered that's already beyond the background noise floor.
6. Margin (dB) = Remark result (dBuV/m) – Average limit (dBuV/m).



Operation Mode: TX / IEEE 802.11n HT40 MHz / CH High Test Date: March 1, 2013

Temperature: 24°C

Tested by: Leevin Li

Humidity: 52% RH

Polarity: Ver. / Hor.

Frequency (MHz)	Reading (dBuV)	Correction Factor (dB/m)	Result (dBuV/m)	Limit (dBuV/m)	Margin (dB)	Antenna Pole (V/H)	Remark
1660.0000	52.00	-8.91	43.09	74.00	-30.91	V	Peak
3325.0000	46.81	-4.03	42.78	74.00	-31.22	V	Peak
4195.0000	46.28	-1.60	44.68	74.00	-29.32	V	Peak
5080.0000	44.94	1.41	46.35	74.00	-27.65	V	Peak
5545.0000	45.40	1.82	47.22	74.00	-26.78	V	Peak
6070.0000	45.84	3.30	49.14	74.00	-24.86	V	Peak
1660.0000	59.23	-8.91	50.32	74.00	-23.68	H	Peak
3895.0000	47.24	-2.51	44.73	74.00	-29.27	H	Peak
4270.0000	46.52	-1.31	45.21	74.00	-28.79	H	Peak
4915.0000	46.06	0.93	46.99	74.00	-27.01	H	Peak
5680.0000	44.75	2.27	47.02	74.00	-26.98	H	Peak
6085.0000	45.27	3.34	48.61	74.00	-25.39	H	Peak

REMARKS:

1. Measuring frequencies from 1 GHz to the 10th harmonic of highest fundamental frequency.
2. Radiated emissions measured in frequency above 1000MHz were made with an instrument using peak/average detector mode.
3. Average test would be performed if the peak result were greater than the average limit or as required by the applicant.
4. Data of measurement within this frequency range shown " --- " in the table above means the reading of emissions are attenuated more than 20dB below the permissible limits or the field strength is too small to be measured.
5. Measurements above show only up to 6 maximum emissions noted, or would be lesser, with " N/A " remark, if no specific emissions from the EUT are recorded (ie: margin>20dB from the applicable limit) and considered that's already beyond the background noise floor.
6. Margin (dB) = Remark result (dBuV/m) – Average limit (dBuV/m).



7.3. 6dB BANDWIDTH MEASUREMENT

7.3.1. LIMITS

According to §15.247(a)(2), systems using digital modulation techniques may operate in the 902 - 928 MHz, 2400 - 2483.5 MHz, and 5725 - 5850 MHz bands. The minimum 6 dB bandwidth shall be at least 500 kHz.

7.3.2. TEST INSTRUMENTS

Name of Equipment	Manufacturer	Model	Serial Number	Last Calibration	Calibration Due
Spectrum Analyzer	Agilent	E4446A	US44300399	03/19/2012	03/19/2013

7.3.3. TEST PROCEDURES (please refer to measurement standard)

1. Place the EUT on the table and set it in the transmitting mode.
2. Remove the antenna from the EUT and then connect a low loss RF cable from the antenna port to the spectrum analyzer.
3. Set the spectrum analyzer as RBW = 1-5 % or DTS BW, not to exceed 100kHz, VBW = $\geq 3 \times$ RBW, Sweep = auto.
4. Mark the peak frequency and -6dB (upper and lower) frequency.
5. Repeat until all the rest channels are investigated.

7.3.4. TEST SETUP

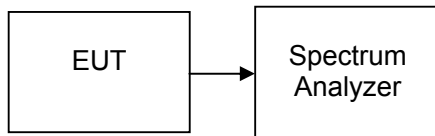



7.3.5. TEST RESULTS

No non-compliance noted

Test Data

Test mode: IEEE 802.11b(Antenna 1)

Channel	Frequency (MHz)	Bandwidth (kHz)	Limit (kHz)	Test Result
Low	2412	10058	>500	PASS
Mid	2437	10048		PASS
High	2462	10056		PASS

Test mode: IEEE 802.11g(Antenna 1)

Channel	Frequency (MHz)	Bandwidth (kHz)	Limit (kHz)	Test Result
Low	2412	16367	>500	PASS
Mid	2437	16388		PASS
High	2462	16371		PASS

Test mode: IEEE 802.11n HT20 MHz(Antenna 01)

Channel	Frequency (MHz)	Bandwidth (kHz)	Limit (kHz)	Test Result
Low	2412	17589	>500	PASS
Mid	2437	17571		PASS
High	2462	17587		PASS

Test mode: IEEE 802.11n HT20 MHz(Antenna 1)

Channel	Frequency (MHz)	Bandwidth (kHz)	Limit (kHz)	Test Result
Low	2412	17591	>500	PASS
Mid	2437	17579		PASS
High	2462	17578		PASS



Test mode: IEEE 802.11n HT40 MHz(Antenna 0)

Channel	Frequency (MHz)	Bandwidth (kHz)	Limit (kHz)	Test Result
Low	2422	35820	>500	PASS
Mid	2437	35611		PASS
High	2452	35749		PASS

Test mode: IEEE 802.11n HT40 MHz(Antenna 1)

Channel	Frequency (MHz)	Bandwidth (kHz)	Limit (kHz)	Test Result
Low	2422	35785	>500	PASS
Mid	2437	35841		PASS
High	2452	35721		PASS



Test Plot

IEEE 802.11b mode(Antenna 1)

6dB Bandwidth (CH Low)

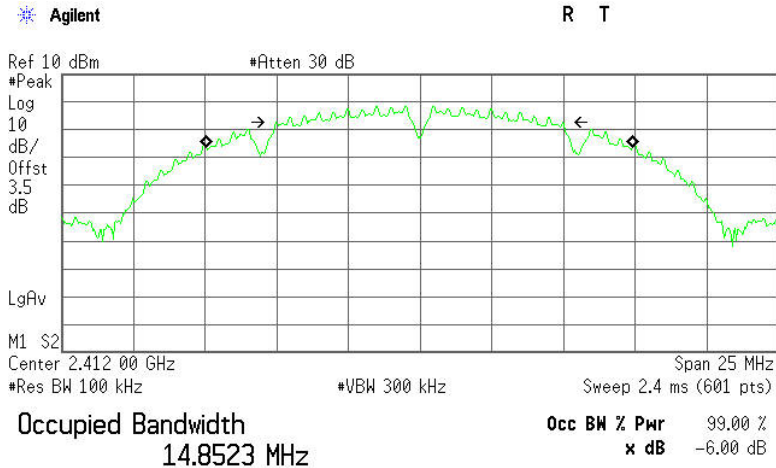

Transmit Freq Error -22.305 kHz
 x dB Bandwidth 10.058 MHz

6dB Bandwidth (CH Mid)

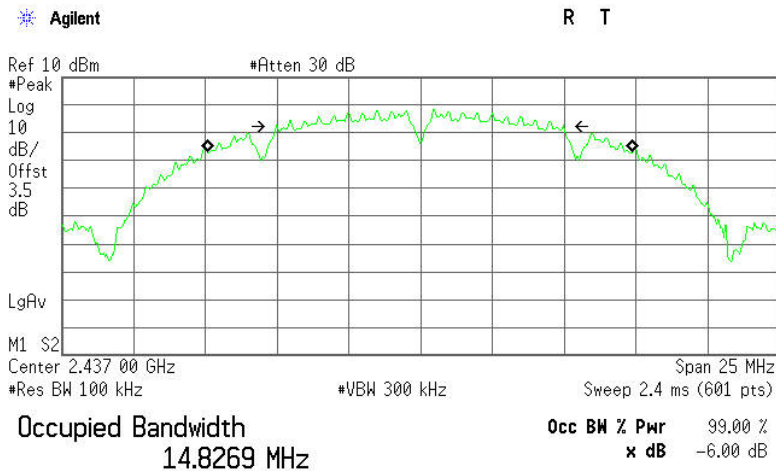

Transmit Freq Error -17.748 kHz
 x dB Bandwidth 10.048 MHz



6dB Bandwidth (CH High)

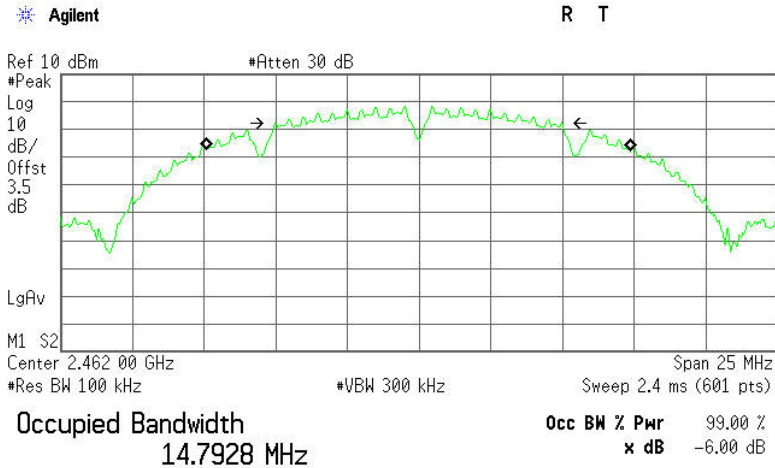

Transmit Freq Error -30.692 kHz
x dB Bandwidth 10.056 MHz

IEEE 802.11g mode(Antenna 1)

6dB Bandwidth (CH Low)

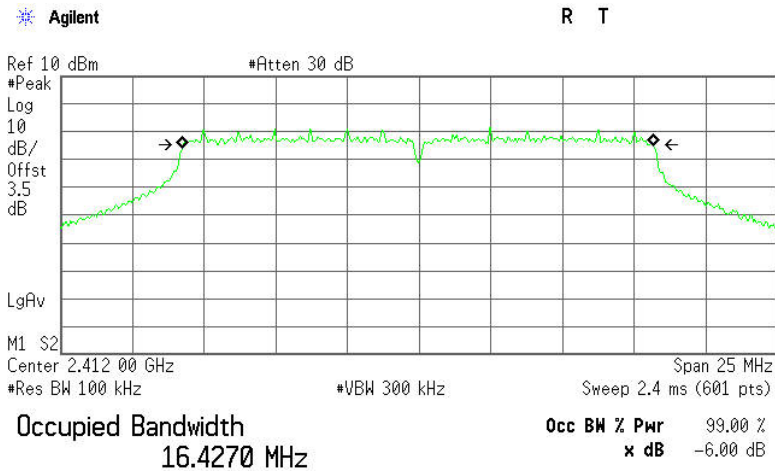

Transmit Freq Error -31.671 kHz
x dB Bandwidth 16.367 MHz



6dB Bandwidth (CH Mid)

Agilent

R T

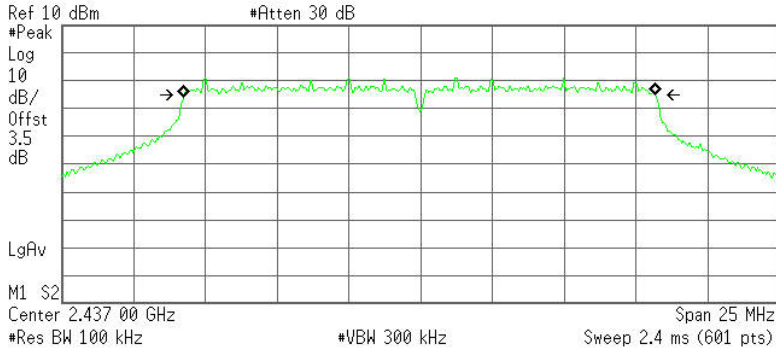

Occupied Bandwidth
16.4235 MHz

Occ BW % Pwr 99.00 %
x dB -6.00 dB

Transmit Freq Error -30.575 kHz
x dB Bandwidth 16.388 MHz

6dB Bandwidth (CH High)

Agilent

R T

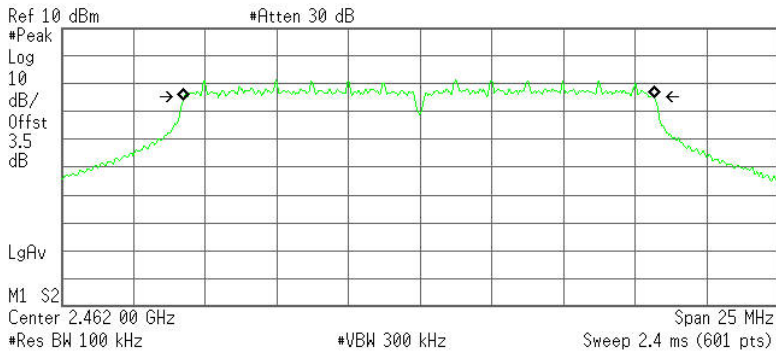

Occupied Bandwidth
16.4123 MHz

Occ BW % Pwr 99.00 %
x dB -6.00 dB

Transmit Freq Error -31.754 kHz
x dB Bandwidth 16.371 MHz



IEEE 802.11n HT20 MHz mode(Antenna 0)

6dB Bandwidth (CH Low)

Agilent

R T

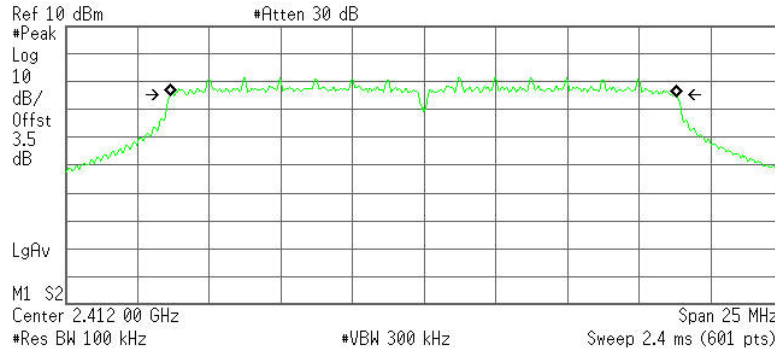

Occupied Bandwidth
17.6568 MHz

Occ BW % Pwr 99,00 %
x dB -6,00 dB

Transmit Freq Error -19,012 kHz
x dB Bandwidth 17,589 MHz

6dB Bandwidth (CH Mid)

Agilent

R T

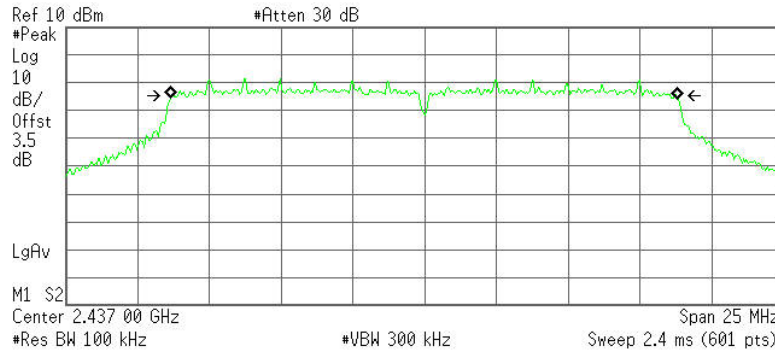

Occupied Bandwidth
17.6404 MHz

Occ BW % Pwr 99,00 %
x dB -6,00 dB

Transmit Freq Error -17,438 kHz
x dB Bandwidth 17,571 MHz



6dB Bandwidth (CH High)

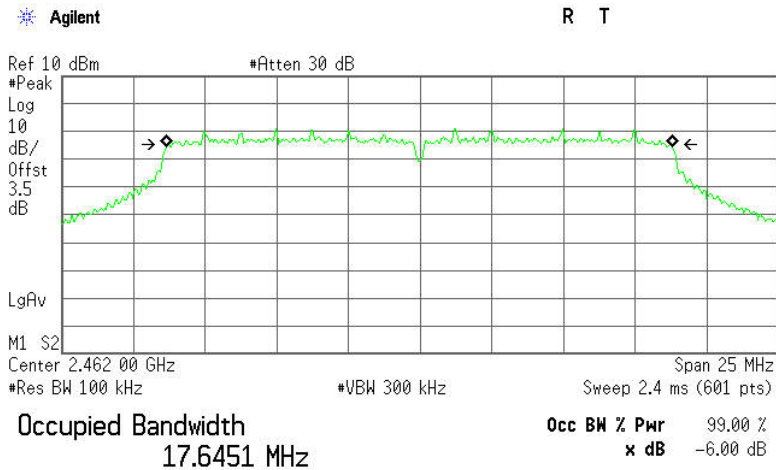

Transmit Freq Error -17.816 kHz
x dB Bandwidth 17.587 MHz

IEEE 802.11n HT20 MHz mode(Antenna 1)

6dB Bandwidth (CH Low)

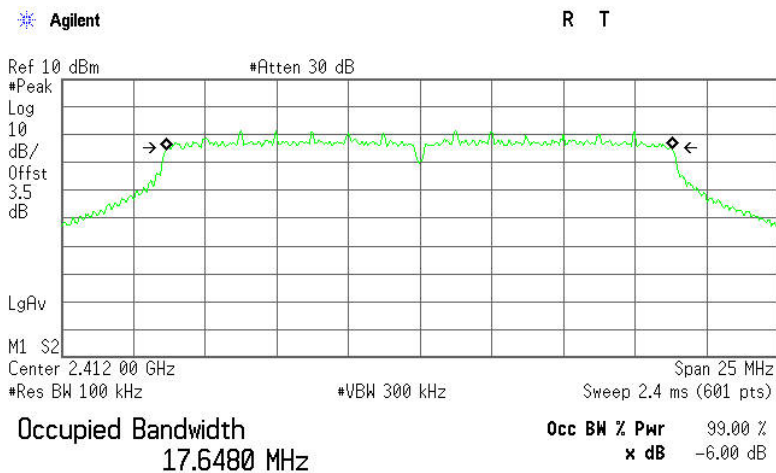

Transmit Freq Error -23.738 kHz
x dB Bandwidth 17.591 MHz



6dB Bandwidth (CH Mid)

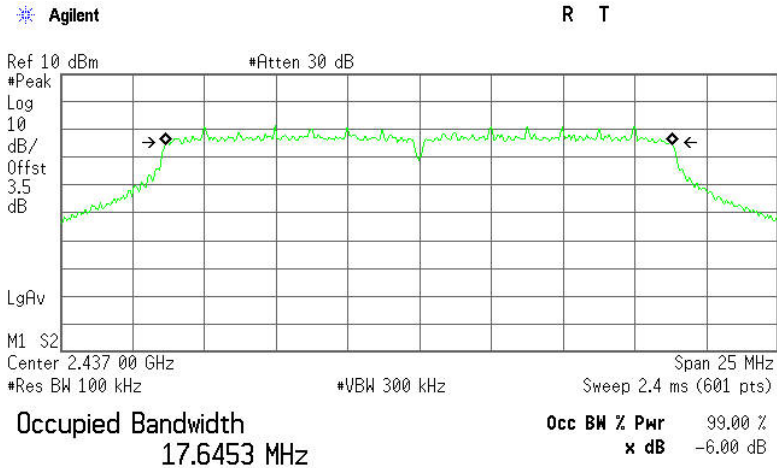

Transmit Freq Error -18.330 kHz
 x dB Bandwidth 17.579 MHz

6dB Bandwidth (CH High)

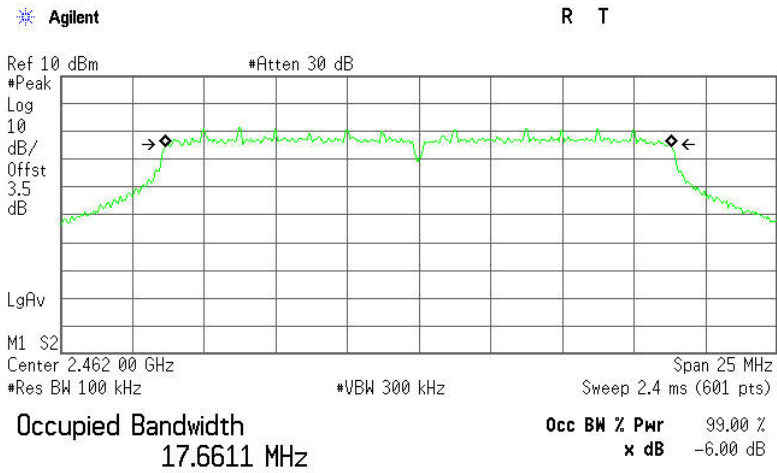

Transmit Freq Error -21.414 kHz
 x dB Bandwidth 17.578 MHz



IEEE 802.11n HT40 MHz mode(Antenna 0)

6dB Bandwidth (CH Low)

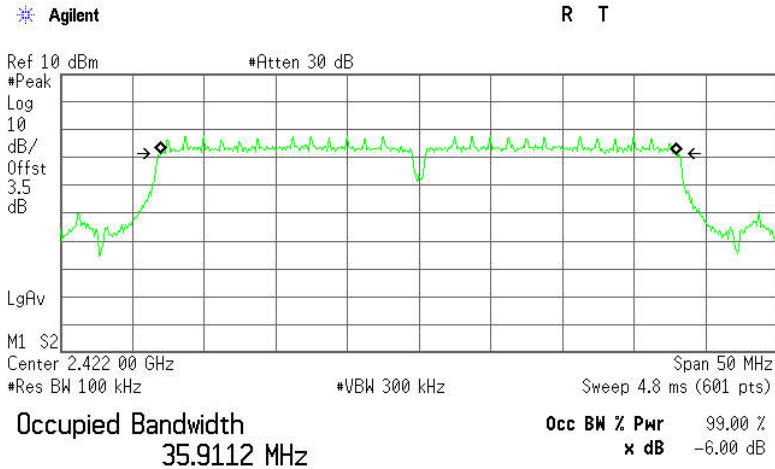

Transmit Freq Error -9.311 kHz
x dB Bandwidth 35.820 MHz

6dB Bandwidth (CH Mid)

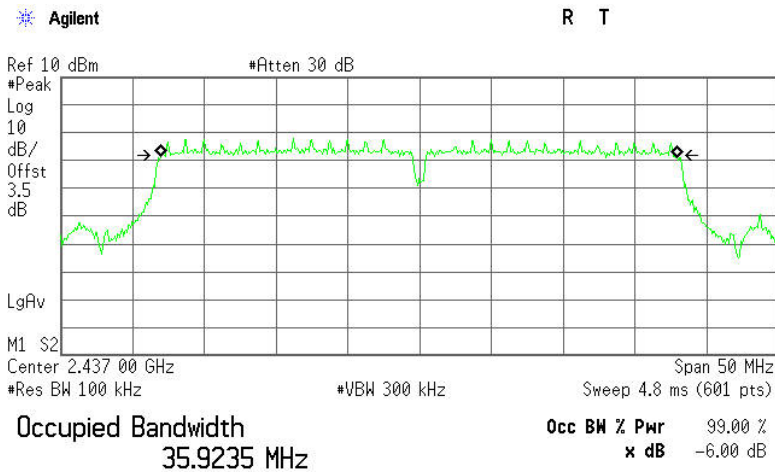

Transmit Freq Error -18.003 kHz
x dB Bandwidth 35.611 MHz



6dB Bandwidth (CH High)

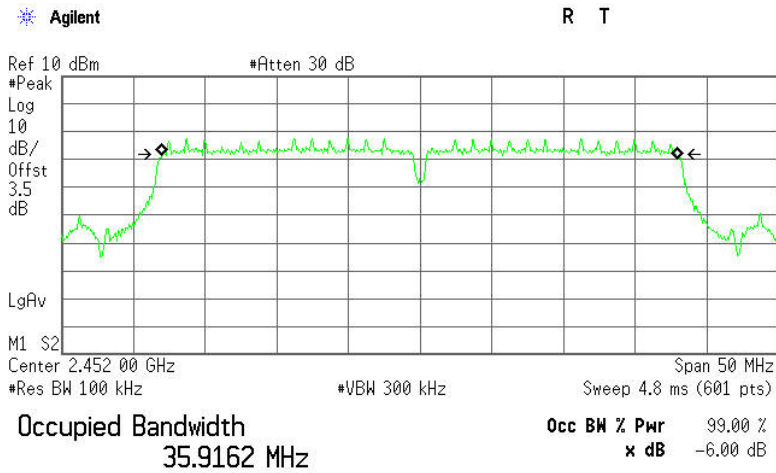

Transmit Freq Error -8.827 kHz
x dB Bandwidth 35.749 MHz

IEEE 802.11n HT40 MHz mode(Antenna 1)

6dB Bandwidth (CH Low)

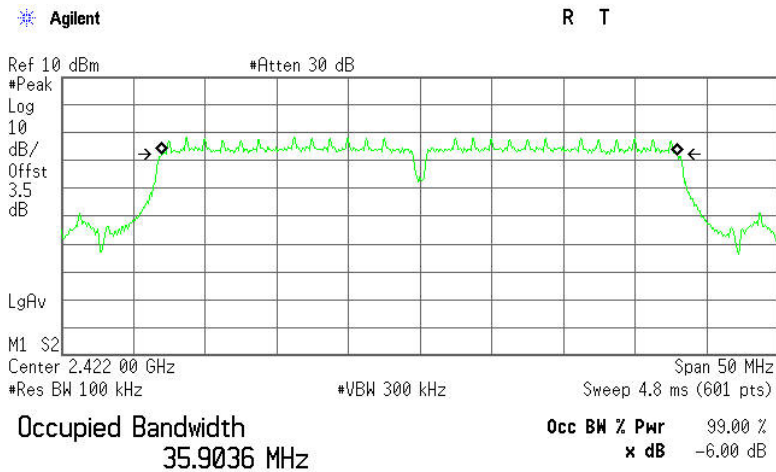

Transmit Freq Error -9.866 kHz
x dB Bandwidth 35.785 MHz



6dB Bandwidth (CH Mid)

Agilent

R T

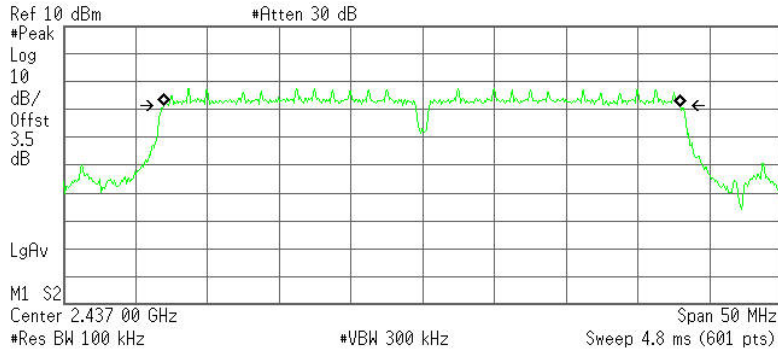

Occupied Bandwidth
35.9006 MHz

Occ BW % Pwr 99.00 %
x dB -6.00 dB

Transmit Freq Error -17.605 kHz
x dB Bandwidth 35.841 MHz

6dB Bandwidth (CH High)

Agilent

R T

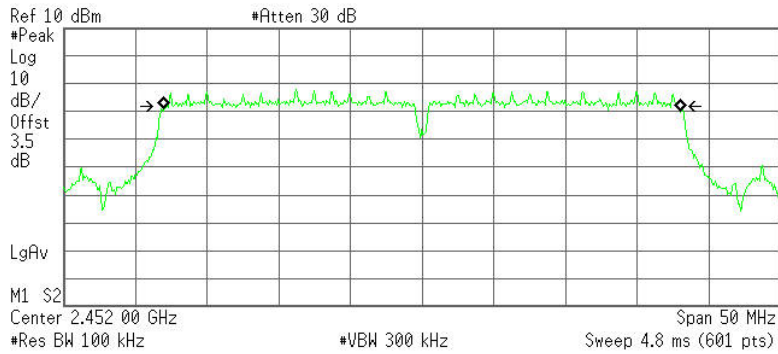

Occupied Bandwidth
35.9255 MHz

Occ BW % Pwr 99.00 %
x dB -6.00 dB

Transmit Freq Error -2.636 kHz
x dB Bandwidth 35.721 MHz



7.4. PEAK OUTPUT POWER

7.4.1. LIMITS

The maximum peak output power of the intentional radiator shall not exceed the following:

1. According to §15.247(b)(3), for systems using digital modulation in the bands of 902-928 MHz, 2400-2483.5 MHz, and 5725-5850 MHz: 1 Watt.
2. According to §15.247(b)(4), the conducted output power limit specified in paragraph (b) of this section is based on the use of antennas with directional gains that do not exceed 6 dBi. Except as shown in paragraph (c) of this section, if transmitting antennas of directional gain greater than 6 dBi are used, the conducted output power from the intentional radiator shall be reduced below the stated values in paragraphs (b)(1), (b)(2), and (b)(3) of this section, as appropriate, by the amount in dB that the directional gain of the antenna exceeds 6 dBi.

7.4.2. TEST INSTRUMENTS

Name of Equipment	Manufacturer	Model	Serial Number	Last Calibration	Calibration Due
Spectrum Analyzer	Agilent	E4446A	US44300399	03/19/2012	03/19/2013

7.4.3. TEST PROCEDURES (please refer to measurement standard)

1. This procedure provides an integrated measurement alternative when the maximum available RBW < EBW.
2. Set the RBW = 1 MHz.
3. Set the VBW = 3 MHz.
4. Set the span to a value that is 5-30 % greater than the EBW.
5. Detector = peak.
6. Sweep time = auto couple.
7. Trace mode = max hold.
8. Allow trace to fully stabilize.
9. Use the spectrum analyzer's integrated band power measurement function with band limits set equal to the EBW band edges (for some analyzers, this may require a manual override to ensure use of peak detector). If the spectrum analyzer does not have a band power function, sum the spectrum levels (in linear power units) at 1 MHz intervals extending across the EBW of the spectrum.



7.4.4. TEST SETUP

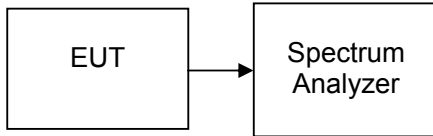

7.4.5. TEST RESULTS

No non-compliance noted

Test Data

Test mode: IEEE 802.11b (Antenna 1)

Channel	Frequency (MHz)	Output Power (dBm)	Output Power (W)	Limit (W)	Result
Low	2412	8.19	0.00659	1	PASS
Mid	2437	6.97	0.00498		PASS
High	2462	5.68	0.00370		PASS

Test mode: IEEE 802.11g (Antenna 1)

Channel	Frequency (MHz)	Output Power (dBm)			Output Power (W)	Limit (W)	Result
		Chain 0	Chain 1	Total			
Low	2422	10.18	4.90	11.31	0.01351	1	PASS
Mid	2437	9.51	3.47	10.48	0.01116		PASS
High	2452	8.90	2.08	9.72	0.00938		PASS

Test mode: IEEE 802.11n HT20 MHz(Combine with Antenna 0 and Antenna 1)

Channel	Frequency (MHz)	Output Power (dBm)			Output Power (W)	Limit (W)	Result
		Chain 0	Chain 1	Total			
Low	2422	10.18	4.90	11.31	0.01351	1	PASS
Mid	2437	9.51	3.47	10.48	0.01116		PASS
High	2452	8.90	2.08	9.72	0.00938		PASS

Test mode: IEEE 802.11n HT40 MHz(Combine with Antenna 0 and Antenna 1)

Channel	Frequency (MHz)	Output Power (dBm)			Output Power (W)	Limit (W)	Result
		Chain 0	Chain 1	Total			
Low	2422	8.32	2.67	9.37	0.00864	1	PASS
Mid	2437	7.83	2.32	8.91	0.00777		PASS
High	2452	7.41	1.53	8.41	0.00693		PASS

Note : Combine Power Calculation :

$$\text{Total Power(dBm)} = \log(10^{(\text{chain 0 power}/10)} + 10^{(\text{chain 1 power}/10)}) * 10$$



Test Plot

IEEE 802.11b mode(Antenna 1)

Peak power (CH Low)

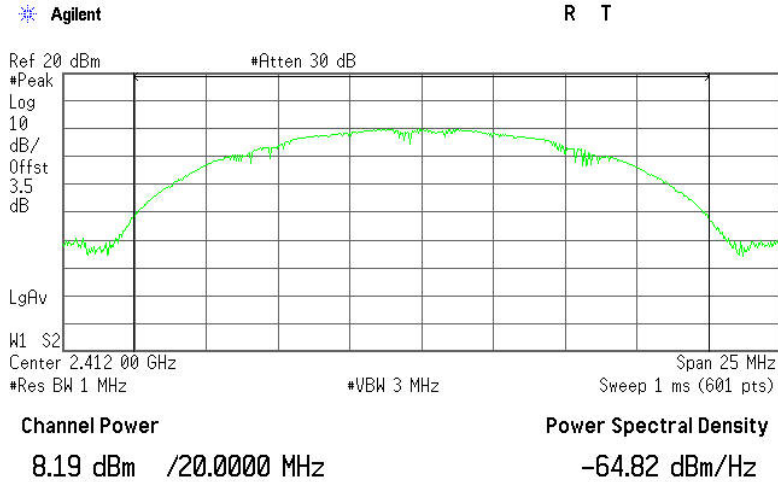

Peak power (CH Mid)

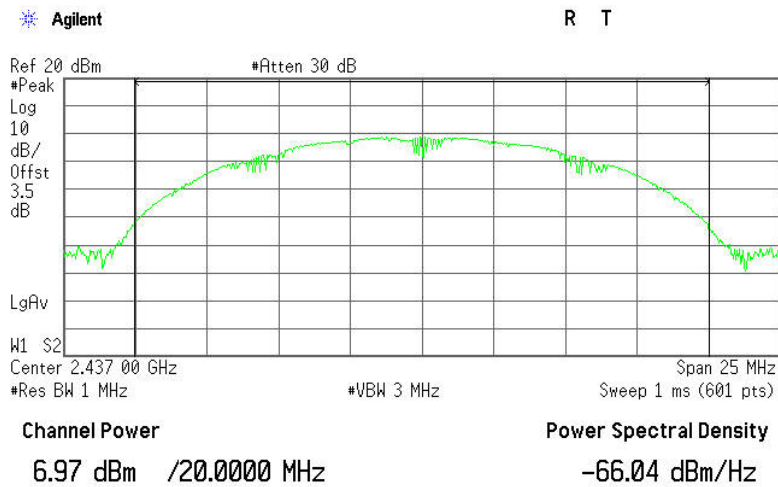



Peak power (CH High)

Agilent

R T

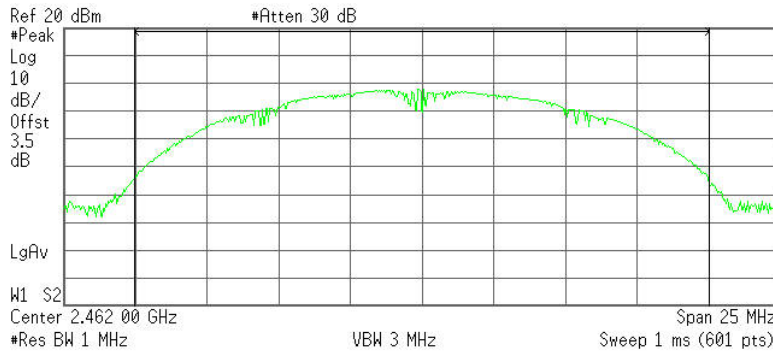

Channel Power

5.68 dBm /20.0000 MHz

Power Spectral Density

-67.33 dBm/Hz

IEEE 802.11g mode(Antenna 1)

Peak power (CH Low)

Agilent

R T

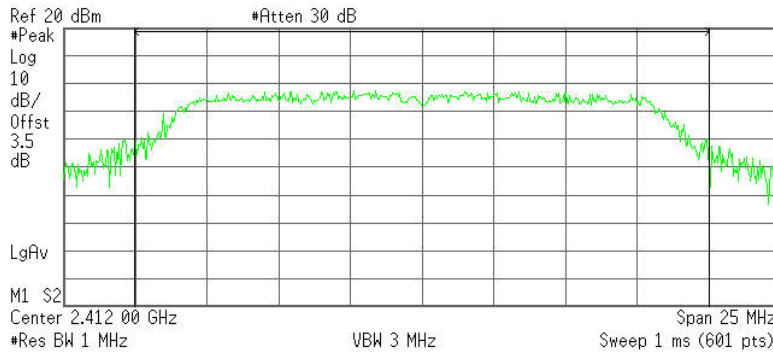

Channel Power

4.70 dBm /20.0000 MHz

Power Spectral Density

-68.31 dBm/Hz



Peak power (CH Mid)

Agilent

R T

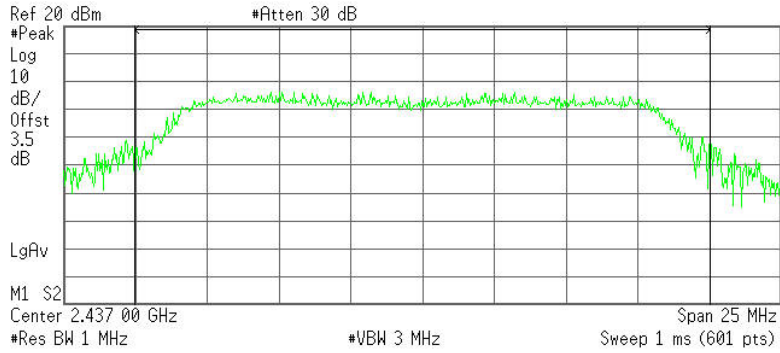

Channel Power

3.64 dBm /20.0000 MHz

Power Spectral Density

-69.37 dBm/Hz

Peak power (CH High)

Agilent

R T

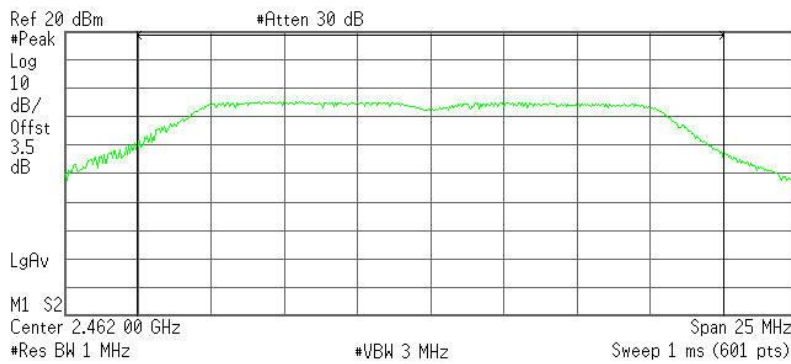

Channel Power

2.16 dBm /20.0000 MHz

Power Spectral Density

-70.85 dBm/Hz



IEEE 802.11n HT20 MHz mode(Antenna 0)

Peak power (CH Low)

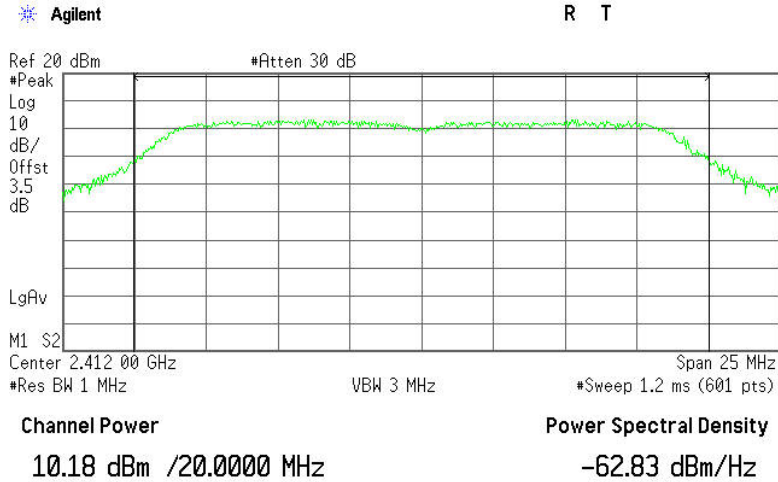

Peak power (CH Mid)

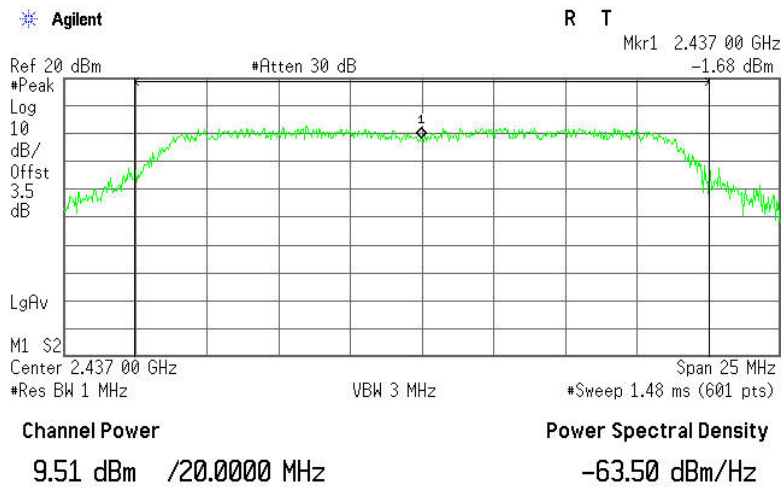



Peak power (CH High)

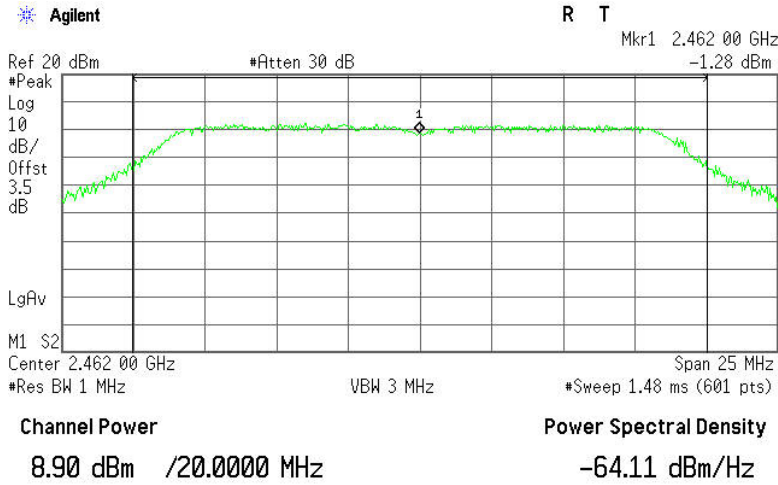

IEEE 802.11n HT20 MHz mode(Antenna 1)

Peak power (CH Low)

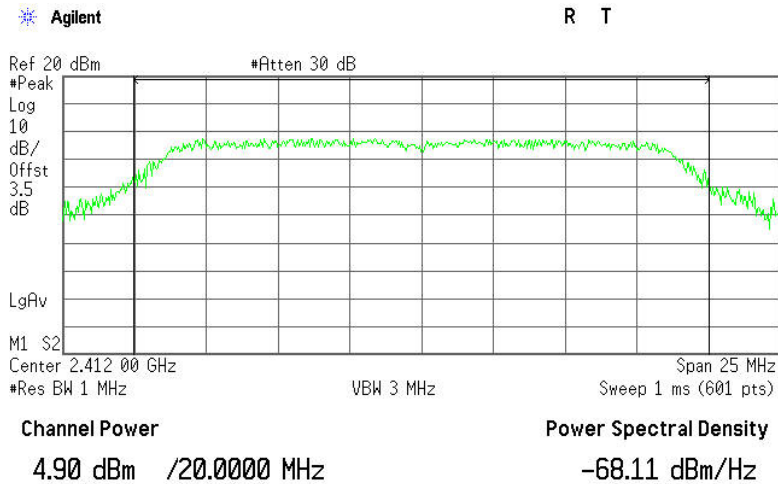



Peak power (CH Mid)

Agilent

R T

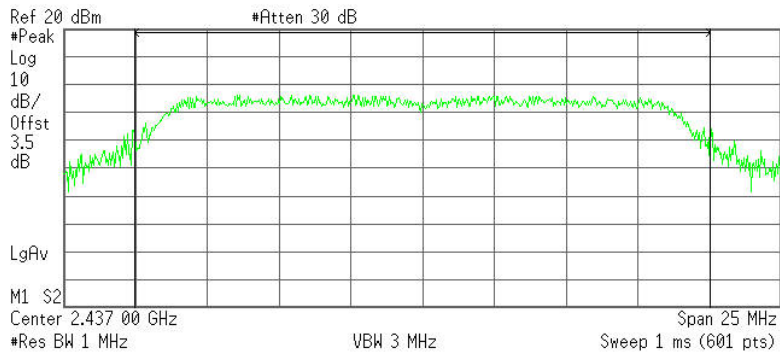

Channel Power

3.47 dBm /20.0000 MHz

Power Spectral Density

-69.54 dBm/Hz

Peak power (CH High)

Agilent

R T

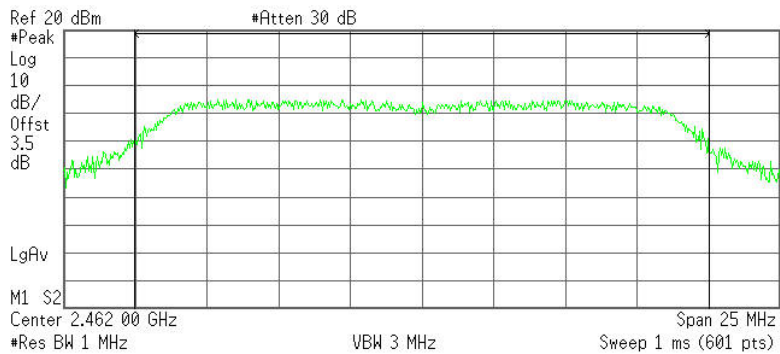

Channel Power

2.08 dBm /20.0000 MHz

Power Spectral Density

-70.93 dBm/Hz