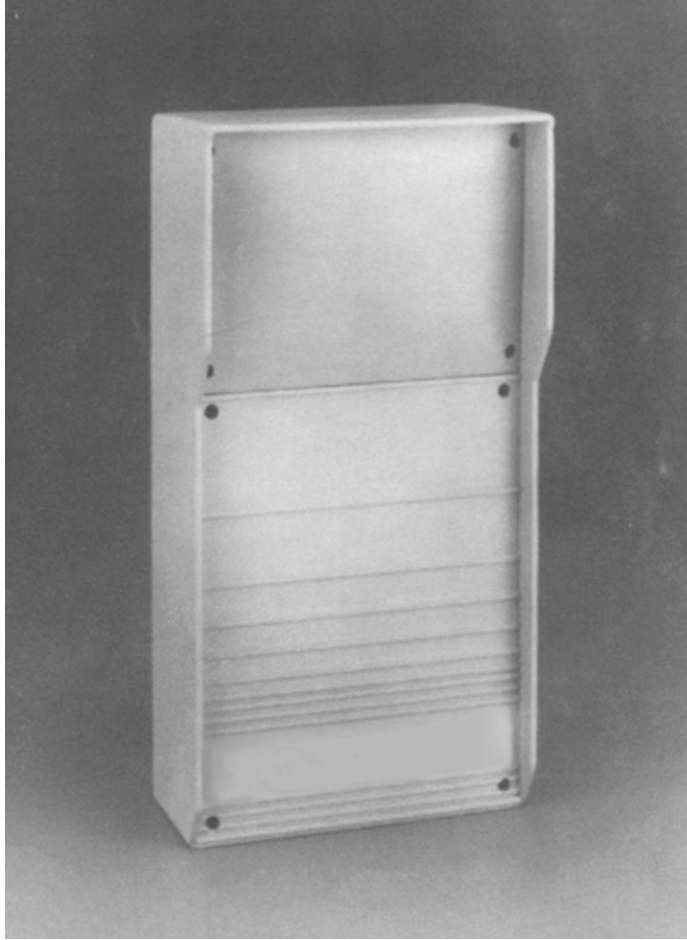

TABLE OF CONTENTS

INTRODUCTION	4
GENERAL SPECIFICATIONS	4
SITE PREPARATION	6
INSTALLATION	7
OFFSETS	10
INSTALLATION – MECHANICAL	11
INSTALLATION – ELECTRICAL	12
TRANSMITTER WIRING	12
OPERATING INSTRUCTIONS	15
ELECTRICAL ALIGNMENT	19
SENSITIVITY ADJUSTMENT	20
THEORY OF OPERATION	21
TROUBLESHOOTING	24
TEST POINTS	24

FIGURE 1: MODEL 24000	4
FIGURE 2: SYSTEM COMPONENTS	6
FIGURE 3: REQUIRED CLEARANCE AREA	8
FIGURE 4: TERRAIN.....	8
FIGURE 5: PHYSICAL PROTECTION.....	9
FIGURE 6: PERIMETER LAYOUT.....	10
FIGURE 7: OFFSET ILLUSTRATION.....	10
FIGURE 8: OFFSET ARRANGEMENTS: TYPICAL HIGH SECURITY INSTALLATION.....	11
FIGURE 9: POST INSTALLATION AND MOUNTING UNITS. ERROR! BOOKMARK NOT DEFINED.	
FIGURE 10: MOUNTING HEIGHT CHART..... ERROR! BOOKMARK NOT DEFINED.	
FIGURE 11: TRANSMITTER WIRING	14
FIGURE 12: RECEIVER WIRING.....	17
FIGURE 13: ANTENNA CONFIGURATIONS	19
FIGURE 14: TRANSMITTER BLOCK DIAGRAM.....	22
FIGURE 15: RECEIVER BLOCK DIAGRAM	23
FIGURE 16: TRANSMITTER CIRCUIT BOARD COMPONENT LOCATION	26
FIGURE 17: RECEIVER CIRCUIT BOARD COMPONENT LOCATION	27



Introduction

The Perimeter Products, inc. Model 24000 Bi-Static Microwave Link consists of a microwave transmitter and a receiver unit. Each system is designed to detect motion in a specified area called a detection zone. This detection zone is established by the transmitter, which sends continuous microwave signals to the receiver. Any motion in the detection zone causes a variation in the received signal strength. These signal variations are detected by the receiver and processed to give an intrusion notification.

Each transmitter and receiver is mounted in a weatherproof enclosure. Each enclosure contains the respective electronic circuitry, and may be wired to report attempts of tampering. An antenna is part of each electronic enclosure. The antenna on the transmitter contains the microwave source. The receiver antenna contains the microwave detector.

This Installation and Operations Manual is intended for the person who will be doing the initial site layout and installation of the PPI Microwave Intrusion Detection System., Model 24000. It provides the information required to install your system from the time of unpacking shipped equipment to verification of an operative system after installation. This manual covers site preparation, installation procedures, operating instructions and general theory of operation

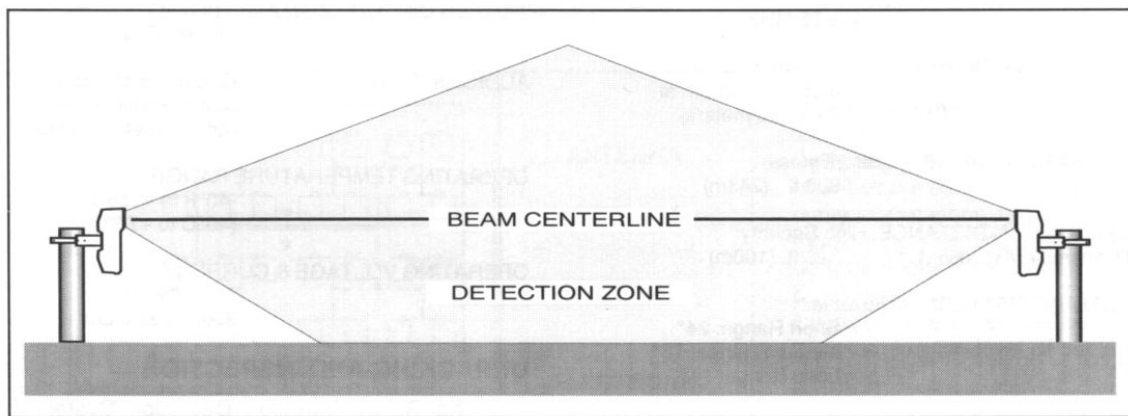

Figure 1: Model 24000

GENERAL SPECIFICATIONS

Circuit Components

100% solid state

Power Requirements	11 to 15 VDC Can be provided by PPI Uninterruptible Power Supply UPS-PFI
Power Consumption	100 MA total per system maximum Transmitter 70 MA Receiver 30 MA
Microwave Carrier Frq.	24.125 GHz +/- 50 MHz
Operating Range	800 ft., 243 meters
Antenna Pattern	Short Range 24° Medium Range 16° Long Range 11°
Antenna Polarization	E-Plane Vertical (E-Plane Horizontal Optional)
Operating Temperature	-40°F to +158°F (-40°C to + 70°C)
Dimensions	6" W X 3.5" D X 12.5 " H 16 cm W X 9 cm D X 32cm H
Weight	5 lbs., 2.25kg
Shipping Weight	8 lbs., 3.5kg

Transmitter Unit

Tamper Circuit Contact	1A, 28 VDC
Modulation	Type: square wave type A2 Channels: 6 field selectable
Microwave Output	Less than .25 volts/meter, maximum at 98 Ft. (30 meters)
Remote Testing	Built-in self-test generator simulates actual intrusion signals

Receiver Unit

Demodulation	Correlated balanced demodulator
Alarm Relay	2A at 28 VDC

Alarm Duration

Adjustable .5 sec. To 10 sec.

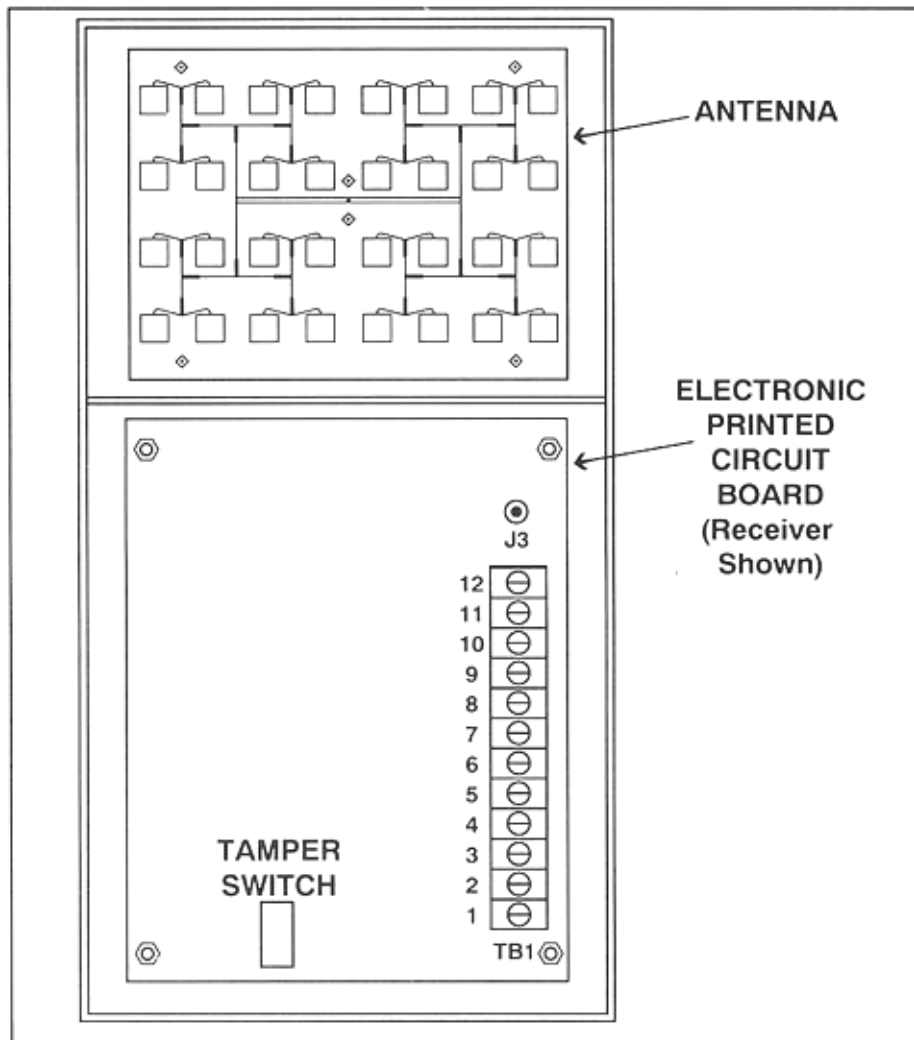

Figure 2: System Components

SITE PREPARATION

Site preparation is necessary for satisfactory performance of the Model 24000 unit. The amount and type of site preparation required depends on the level of security desired. The physical specifications for a high security detection zone are:

- Transmitter/receiver separation distance no longer than 328 ft. (100 meters)
- Terrain must be level to grade, +/- 3 in. (7.6cm)

- Terrain void of vegetation
- Transmitter/receiver units mounted 24 in. (60cm) beam centerline (center of antenna) to ground

When physical properties of the detection zone are not within these parameters, the system capabilities are diminished. High security applications require much more stringent specifications than do applications where only a beam-break alarm is required. The following parameters should be used to determine the level of security required.

High Security Zone – Detection of intruder stomach-crawling parallel to the beam

Medium Security Zone – Detection of intruder crawling on hands and knees.

Low Security Zone – Beam-break alarm only – detection of a walking intruder, vehicles, etc. (not recommended)

INSTALLATION

Installation should begin with a survey of the area to be covered to ensure that it meets the site requirements. After the location of Transmitters and Receivers has been determined, poles should be set and conduit terminated. The Model 24000 can then be mounted, wiring completed and the system configured by setting the appropriate jumpers and switches.

Location of Model 24000

1. Required area. The length of each zone must be established first. The width of the zone will be determined by the amount of open space to the left and the right of centerline between the Transmitter and Receiver. Generally, there should be a clear open space that exceeds one half the pattern width on each side.

The area to be protected should be free of obstructions and moving objects such as trees, shrubs, bushes, obstacles such as utility boxes and other structures. Refer to Figure 3.

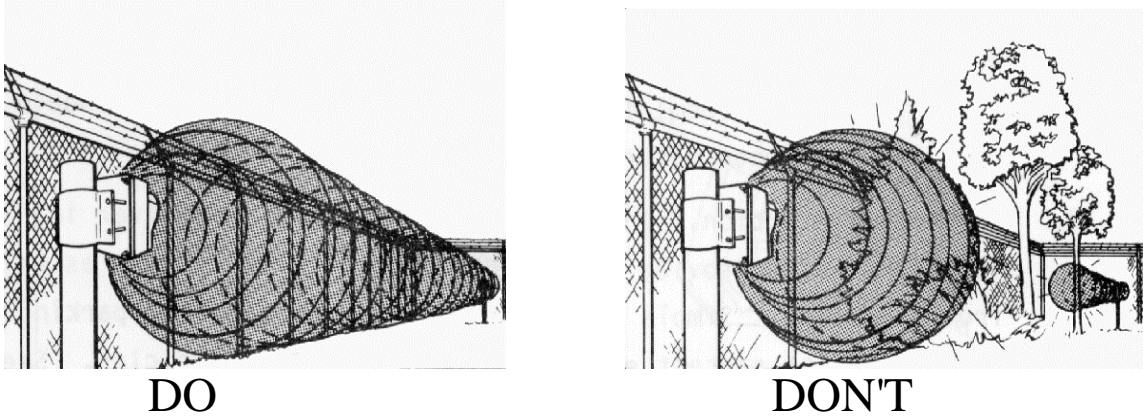

Figure 3: Required Clearance Area

2. Terrain Since operation of the link requires transmission of energy from Transmitter to Receiver, it is important to maintain a clear line of sight between the units; therefore, the ground must be flat across the protected area. Any bumps, hills or ditches must be filled so that the area is flat to within (6) inches (15cm). Refer to Figure 4.

The protected area can be any stable, reasonably smooth material such as concrete, asphalt, tilled earth, or gravel. If there is grass or vegetation in the protected area, it must be kept cut to a maximum of three (3) inches (8cm) in height. A Model 24000 should not be operated over open water, or where standing puddles will form.

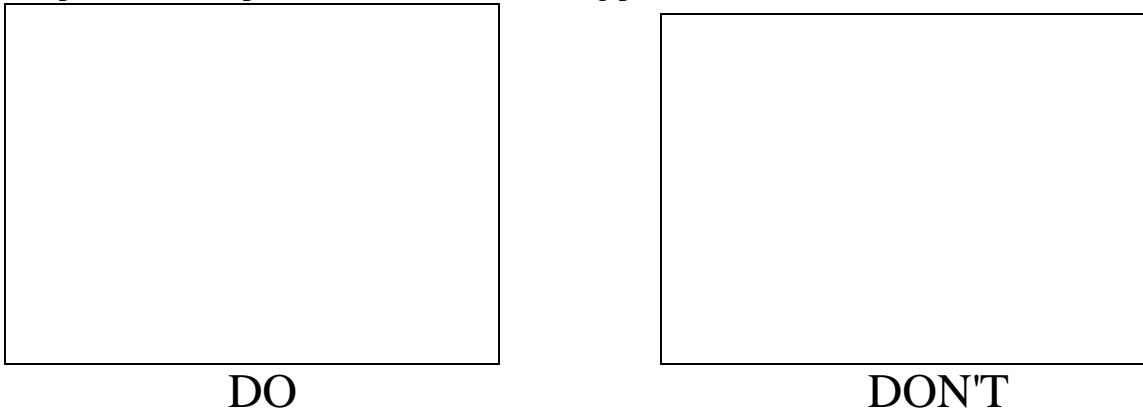

Figure 4: Terrain

3. Microwave Signal Considerations. Microwave signals can pass through common construction materials such as glass, plaster and drywall. Microwave signals will reflect off of solid objects and metallic surfaces.

Microwave signals will pass through standard chain link fences if the beam axis is at a right angle to the fence. The more the fence deviates from a right angle to the beam, the less signal penetration, and the more reflection.

Microwave signals that detect a moving or "flexing" fence, or other large metallic objects, can generate nuisance alarms. The large size of a metallic object can cause a small amount of motion to appear as a large moving object.

Other potential nuisance alarm sources include: moving machinery parts, as well as the vibrations caused by machinery, large vehicles such as trucks, buses and aircraft.

4. Physical Protection. Install the Transmitter and Receiver in a location which provides protection from accidental damage as well as from tampering. If units must be installed near roadways or where they will be vulnerable to vehicle traffic, installing devices such as bumper posts or parking guards can provide additional protection. See Figure 5.

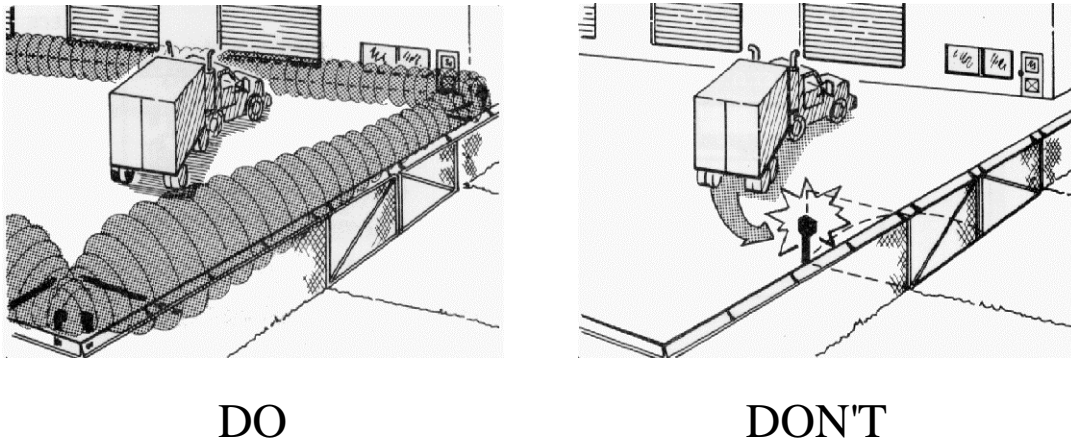

Figure 5: Physical Protection

5. Optimum Security. Choose a location that will provide optimum security, yet be free from nuisance alarms. Always locate Model 24000 inside a fence or controlled access area to prevent unwanted alarms due to random foot traffic, vehicles, or animals.

Units should be located several feet away from parallel fences to avoid reflection of the microwave signal off the surface of the fence, and to prevent the possibility of jumping over the protection pattern.

For maximum security it is necessary to overlap the ends of links so that the dead spot below and immediately in front of the adjoining link is protected. A 15 foot overlap is required at corners and a 30 foot overlap at intermediate points. The offset of overlapping in-line links should be approximately 18 inches (46cm), measured from the center of each unit.

Note that at each point of overlap either two Transmitters or two Receivers should be installed. This arrangement prevents an adjacent Transmitter and Receiver from

establishing an unwanted link across the short overlap distance which could result in a Jam or Wrong Channel indication at the Receiver. Refer to Figure 6.

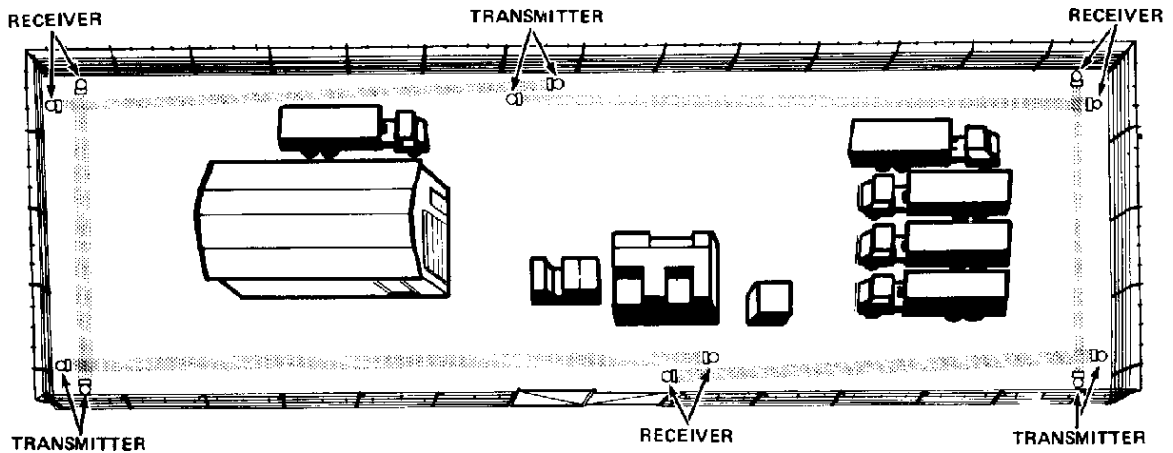

Figure 6: Perimeter Layout

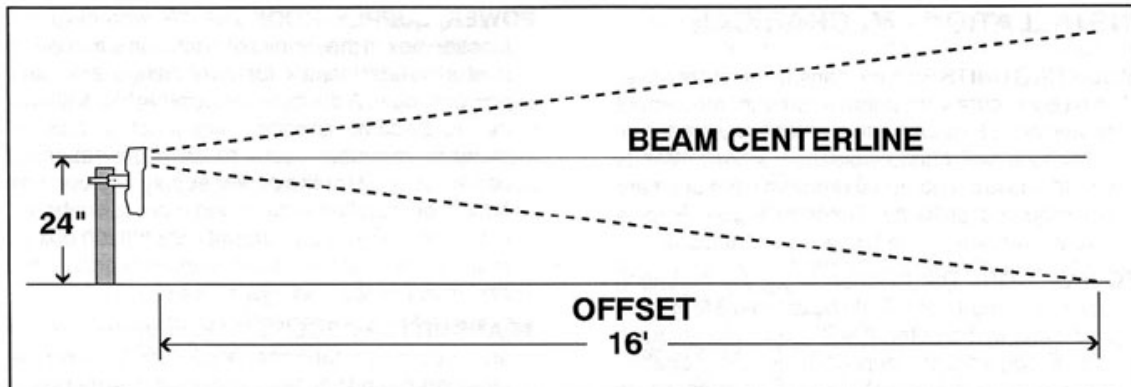

Figure 7: Offset Illustration

OFFSETS

The area immediately below the transmitter/receiver antenna is not exposed to the sensor system's microwave energy. To compensate for this unmonitored area, an offset of the sensor system is required. (see Figure 7). Offsets prevent the possibility of intruders crawling under or jumping over a transmitter or receiver to gain access to the protected area. The offset distances are based on the transmitter/receiver mounted at a height of 24 inches (beam centerline to ground). As the mounting height of the transmitter or receiver is increased, a longer offset is necessary. Different types of offsets are shown in Figure 8

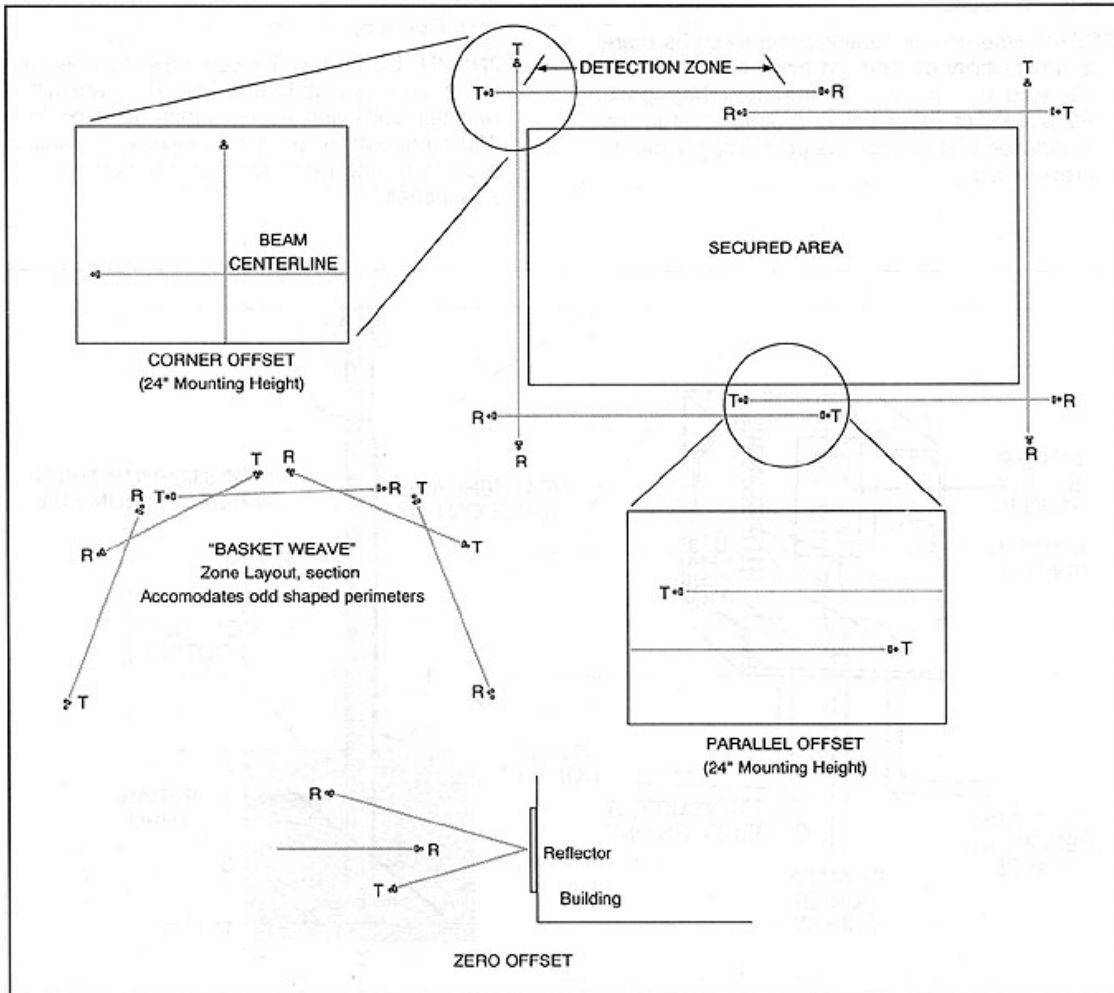

Figure 8: Offset Arrangements: Typical High Security Installation

INSTALLATION – MECHANICAL

Mounting Units

Both the transmitter and receiver must be securely mounted to prevent movement or vibration. Excessive movement or vibration of either unit will cause nuisance alarms. Windy conditions are a potential problem if the units are not mounted properly. Refer to Figure 9 for a visual overview of the following instructions.

Foundation

The foundation for the mounting posts in normal soil should be at least 3 feet deep and 2 feet in diameter. If soil conditions are such that a non-shifting foundation is questionable, then a larger footing should be considered. In areas where extremely low temperatures may cause frost heaving, use a truncated pyramid base foundation.

Node Curves

The node curves (N1, N2, N3, and N4) represent the pivot point for coordinating distance (horizontal axis) to mounting height (vertical axis). Those mounting height and distance coordinate lines that meet in the area between the node curves should be avoided. Coordinate lines that meet on the node curves are preferred because they will result in higher signal strength at the receiver and a wider fade margin. However, choosing a mounting height at N1 or below will allow satisfactory system operation.

Example:

The distance between the transmitter and receiver is 300 feet. Locate the distance on the height chart's horizontal axis. Plot a vertical line from this distance point across the node curves. These height measurements represent the best theoretical mounting heights for this example. They are 33" or less for the N1 curve and below, 55" for the N2 curve, etc.

INSTALLATION – ELECTRICAL

Power Supply

A power source of 12VDC (11 to 15VDC) is required by both the transmitter and receiver units. It is recommended that primary power be brought to the base of each unit's mounting post and terminated in a weatherproof enclosure. This weatherproof enclosure may then be used as a convenient tie point between the transmitter or receiver, the primary power, and the alarm reporting panel. !!% VAC power must not be brought into the enclosure of either the transmitter or receiver unit. Refer to INSTALLATION – MECHANICAL for installation of a junction box to house the primary power supply.

WARNING

When using one DC power supply to power more than one system, ensure the wiring between the power supply and the unit is sufficient to prevent the input voltage at the unit from dropping below 11VDC when the receivers are not in alarm (maximum current draw).

TRANSMITTER WIRING

Refer to Figure11 for a wiring diagram of the transmitter. It is suggested that an installation wiring diagram be made before wiring the transmitter. This will standardize the wiring of the transmitters in a multiple system installation.

Power Source

Terminals 1 and 2. The transmitter requires 12VDC (11 to 15VDC) to operate.

Tamper Reporting

Terminals 3, 4 and 5. The 12VDC power supply to the transmitter may be connected so that when the electronic enclosure is opened, the transmitter is disabled and the receiver goes into constant alarm. To have a specific tamper alarm report, wire the tamper reporting signal directly onto terminals 3 & 4 or 4 & 5 and wire power directly to

terminals 1 & 2. Use a twisted/shielded pair #18 wire for the tamper signal wiring. This wire should be run from the dry contact tamper output terminals to the junction box and on to the alarm reporting panel.

Junction Box

A tamper switch installed in the power supply junction box may also be wired for tamper reporting. This is done in conjunction with the electronic enclosure tampering wiring and both are connected to the alarm reporting panel.

Remote Self Test

Terminals 6 or 7. The transmitter is capable of providing a test signal that will dynamically test the detection zone to the sensitivity required of that zone. This capability can be remotely activated by applying a +5 to +15VDC voltage at terminal 6 of the terminal board or by a ground to terminal 7 of this terminal board. A shielded wire should be used for this connection regardless of the self test actuation method used.

Receiver Wiring

Refer to Figure 12 for a wiring diagram of the receiver unit. It is suggested that an installation wiring diagram be made before wiring the receiver. This will standardize the wiring of receivers in a multiple system installation.

Power Source:

Terminals 1 & 2. The receiver unit requires 12VDC (11 to 15 VDC). Terminal 1 is negative, 2 is positive.

Tamper Reporting

Terminals 3,4 and 5

Series Tamper Alarm

You may wire the receiver tamper switch (terminals 3 & 4 or 4 & 5) in series or parallel (depending on alarm relay logic) with the alarm contacts for a non-specific alarm report. A non-specific alarm report does not indicate whether the alarm was caused by intrusion detection or tampering with the unit electronics enclosure. A twisted/shielded pair of #18 wire should be used for this connection.

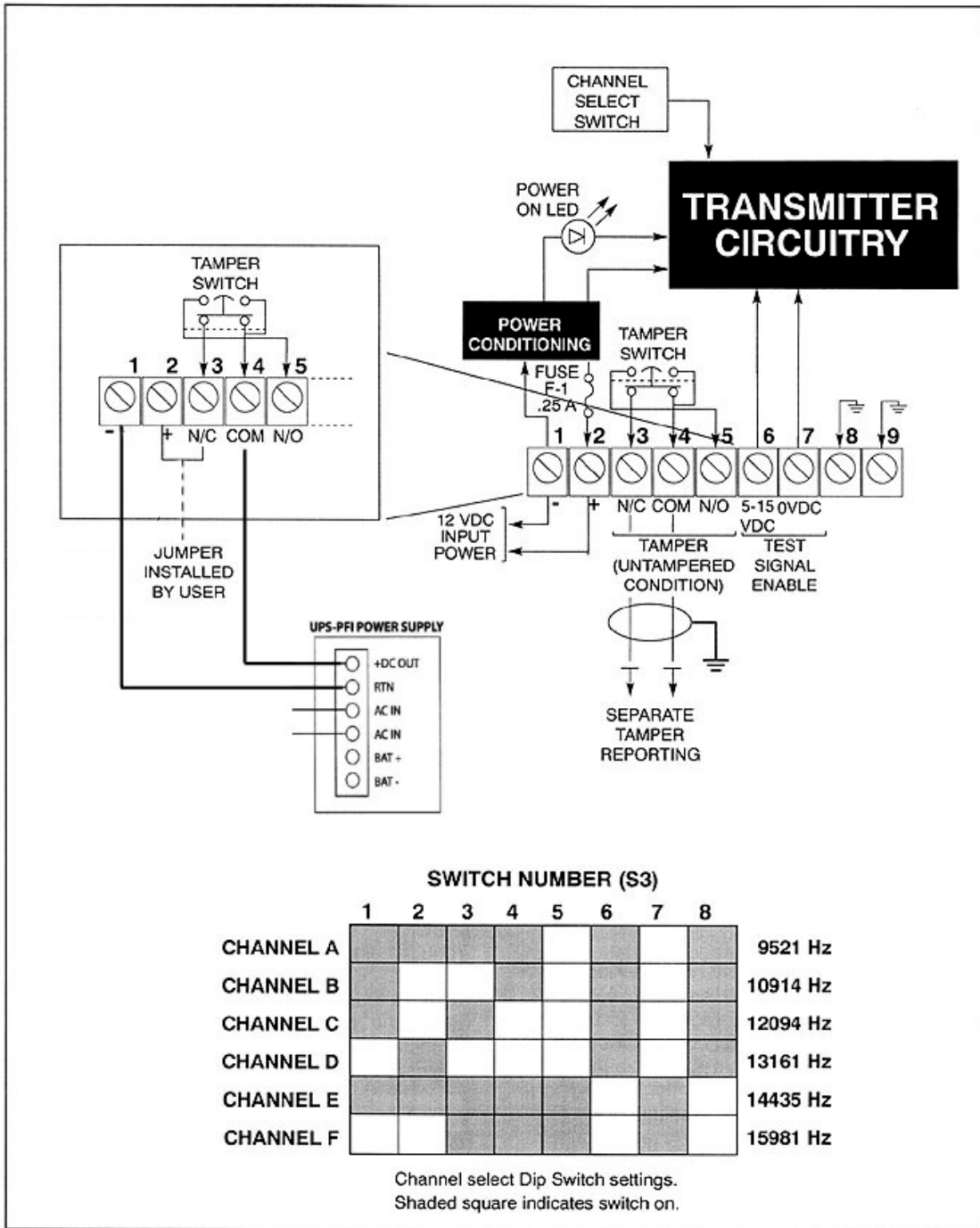

Figure 11: Transmitter Wiring

Specific Tamper Reporting

To have a specific tamper alarm report, wire the tamper reporting signal directly onto Terminals 3 & 4 or 4 & 5. Use a twisted/shielded pair of #18 wire for the tamper signal wiring. This wire should be run from the dray contact tamper output terminals to the junction box and onto the alarm reporting panel.

Alarm circuit

Terminals 6,7,8,9,10 and 11. There are two sets of normally open and normally closed relay contacts (dry); one set may be used for alarm annunciation at the alarm-reporting panel. The other could be used for local annunciation, zone certification testing, etc. Use a twisted/shielded pair of #18 wire to connect the alarm notification to the junction box and alarm reporting panel.

Multipath Sidetone

Phono plug adjacent to Terminal 12. This is an audio output (2 milliwatts, 600 Ohm) whose frequency and amplitude are proportional to the amount and locations of a source of motion within the detection zone. It can be used as a local test signal, or can be amplified and connected to the alarm monitoring system. Shielded #18 audio wire should be used to connect this signal to the annunciator.

OPERATING INSTRUCTIONS

Once the following preliminary checks, alignment and sensitivity adjustments are accomplished, the PPI 24000 unit is ready to operate. There are no controls or indicators for operating the sensor system, and no alternate operating modes during emergency conditions.

Preliminary Check

Once the sensor system is mounted and wiring installation completed, a preliminary check, channel selection, and antenna pattern selection is required before applying power to the system.

Channel Select Switch

Refer to the Channel Selection Matrix Chart on the Receiver and Transmitter Wiring Illustration. The channel select switch on each transmitter/receiver pair must be set to the same operating channel.

Range Switch

This is a small jumper on the receiver circuit board located by the coax input from the antenna. Put this jumper in the "S" position for separation distances of less the 100 feet; use the "L" position for ranges greater than 100 feet.

Latch/Timed Jumper

This is a white jumper wire located adjacent to terminals 9,10 & 11. On the receiver circuit board. When the jumper is in the TIMED position, the setting of R76 DURATION controls the alarm duration, which is user-adjustable between .5 seconds and 10 seconds. The LATCH position, once the system goes into alarm, it will stay in alarm until the jumper is moved to the TIMED position. This jumper must be in the TIMED position for normal operation; the LATCH position is used during electrical alignment of the system.

Sensitivity Jumper

The position of the Sensitivity Jumper is determined by the application requirements. L = Low Security, M = Medium Security and H = High Security. This jumper effectively reduces the maximum alarm sensitivity, preventing excessive sensitivity that may result in nuisance alarms.

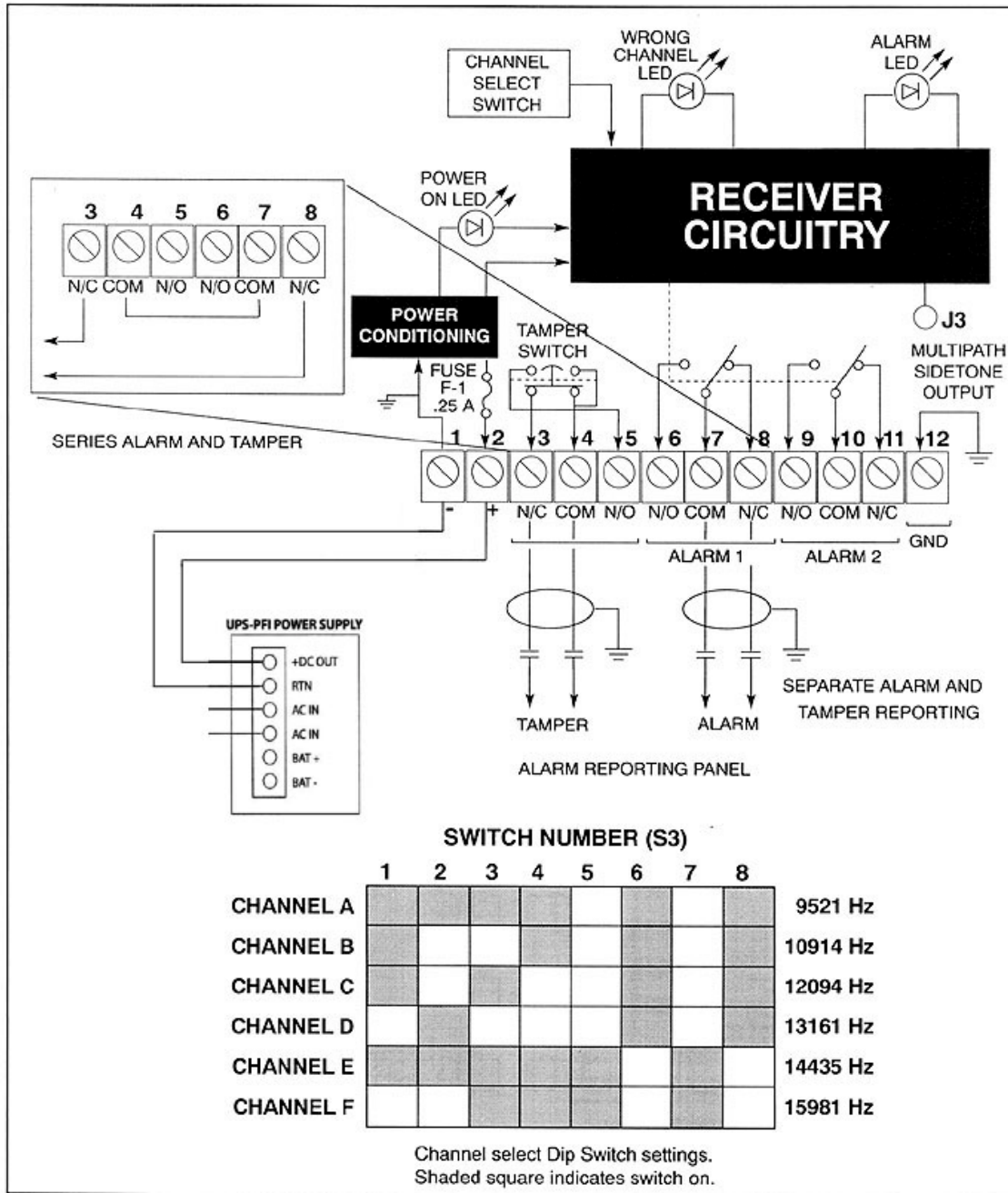

Figure 12: Receiver Wiring

Antenna Pattern

The detection pattern is adjustable by use of the sensitivity adjustment and by changing the configuration of the transmitting and receiving antenna. Installing RF absorbent pads over selected antenna elements (see Figure 13) changes the antenna configuration. When no antenna pads are installed, the microwave beam is narrowest (11 degrees). With eight of the elements covered, the beam is 16 degrees, and with sixteen of the elements covered, the pattern is 24 degrees. In general, the wide pattern should only be used when the separation distance between receiver and transmitter is 50 feet or less. The medium range pattern should be used (if necessary) with separation distances of between 50 and 100 feet. The narrowest pattern (unmodified antenna) must be used when the separation distance is greater than 100 feet. Always use the narrowest beam possible commensurate with detection requirements.

Install the absorbent pads on both the receiver and transmitter pair in accordance with the following instructions:

- 1 Select the number of strips of double-backed tape that will cover the elements necessary to provide the desired detection pattern. Remove the paper backing, and stick the tape over the elements to be covered. *Cover only the elements shown in the illustration.*
- 2 Remove the other piece of paper backing from the tape, and firmly press the RF absorbent material to it.
- 3 Be sure that both the transmitting antenna and the receiving antenna configurations are identical.

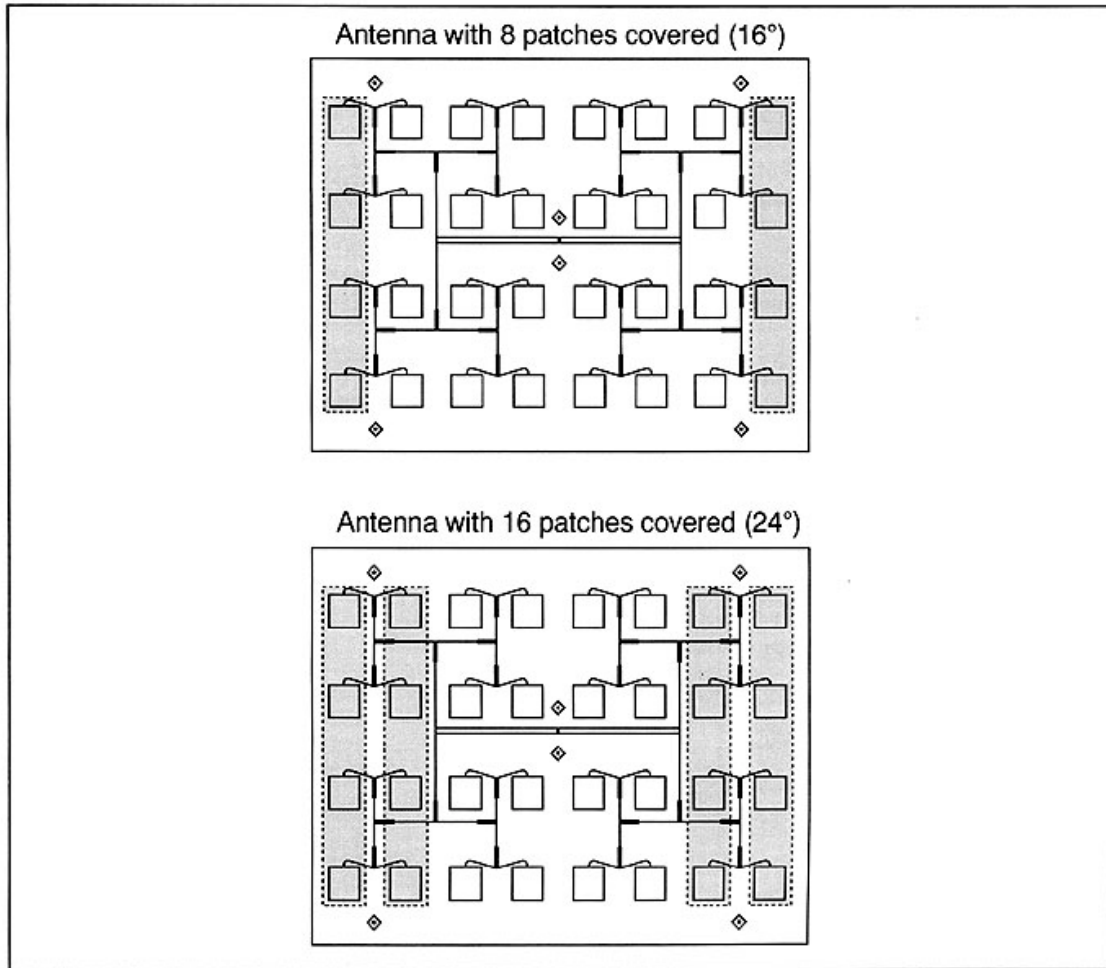

Figure 13: Antenna Configurations

ELECTRICAL ALIGNMENT

An electrical alignment requires the antennas of both the transmitter and receiver to be looking head-to-head. Verify initial mechanical alignment. Once this initial mechanical alignment is done, a more precise electrical alignment is required. *The transmitter/receiver units should never be aimed into the ground or off to the side of the detection zone. However, discontinuities in the detection zone may dictate an alignment slightly off head-to-head.*

NOTE: During this alignment procedure, place the LATCH/TIMED jumper on the receiver circuit board in the LATCHED position. This will speed up the response time of the AGC voltage to make the adjustment easier.

AGC Measurements

At the receiver, connect a digital voltmeter between TP-10 (+) and TB1-1 (-). This is the automatic gain control (AGC) voltage, and, after final alignment as outlined below, should be between 1.7 and 7.3 VDC. Put the SHORT-LONG jumper in the LONG position to increase the AGC voltage and in the SHORT position to decrease the AGC voltage.

Receiver

Slowly move the receiver unit up and down the post while monitoring the receiver unit AGC voltage. Once a maximum AGC voltage is obtained, rotate the receiver until maximum AGC is obtained on this axis. Tilt the receiver antenna up and down, again adjusting for maximum AGC voltage.

Transmitter

Continue to monitor the AGC voltage at the receiver while moving the transmitter in all three axes until maximum AGC voltage is obtained

Final Alignment

After securing hardware, repeat the transmitter and receiver unit electrical alignment steps for obtaining maximum AGC reading on all the rotational axes.

Secure Hardware

Secure the mounting nuts and bolts. Ensure the AGC voltage remains high while this hardware is tightened. If the final AGC voltage is greater than 4.0 volts put the SHORT-LONG jumper in the SHORT position; this will reduce the voltage to the 2.5 to 3.0 volt ranges. Move the LATCHED-TIMED jumper to the TIMED position for normal alarm operation.

SENSITIVITY ADJUSTMENT

Before beginning a sensitivity adjustment, make sure the receiver “ALARM” LED is not lit. Connect an ohmmeter between TB1 terminals 10 and 11; it will read less than 0.5 ohms when the system is operational (armed) and infinity when the unit is in alarm, Leave the ohmmeter connected.

Alarm Test

A preliminary alarm test requires walking across the detection zone to ensure the unit goes into alarm (“ALARM LED” lit, ohmmeter to infinity). If it does not, adjust the sensitivity potentiometer (R55) clockwise; then walk test the zone again. An alarm report should normally occur before the walker breaks a line of sight between the transmitter and receiver units.

Final Alarm Test

Determine the level of security sensitivity desired, and then use the following parameters for ensuring that the level desired is present.

NOTE: Start with the sensitivity jumper in the “L” position – change to “M” or “H” if unable to get the required detection with adjustment of R55 alone. The final adjustment setting should be the lowest setting possible that provides the required detection.

Low security – walk across detection zone. Adjust R55 for consistent detection.

Medium security – crawl across detection zone on hands and knees. Adjust R55 for consistent detection

High security – pull ball (see High Security); pull often enough to give confidence that the zone has the sensitivity you want,

High Security

Adjustment for a typical high security application requires the detection of a prone human crawling through the detection zone with the length of the body parallel to the line of sight. A 13 inch (30.5cm) metal sphere represents approximately the same target to the microwave sensor.

When adjusting the sensitivity to high security specifications slowly (5"/sec or faster) pull the sphere through the zone (perpendicular to the line of sight) approximately every 10 feet (3m) and adjust the sensitivity potentiometer R55 until repeatable detection is obtained. Dragging the ball in the offset area is not necessary.

THEORY OF OPERATION

Transmitter

Here is a functional block diagram of the transmitter unit for the model 24000.

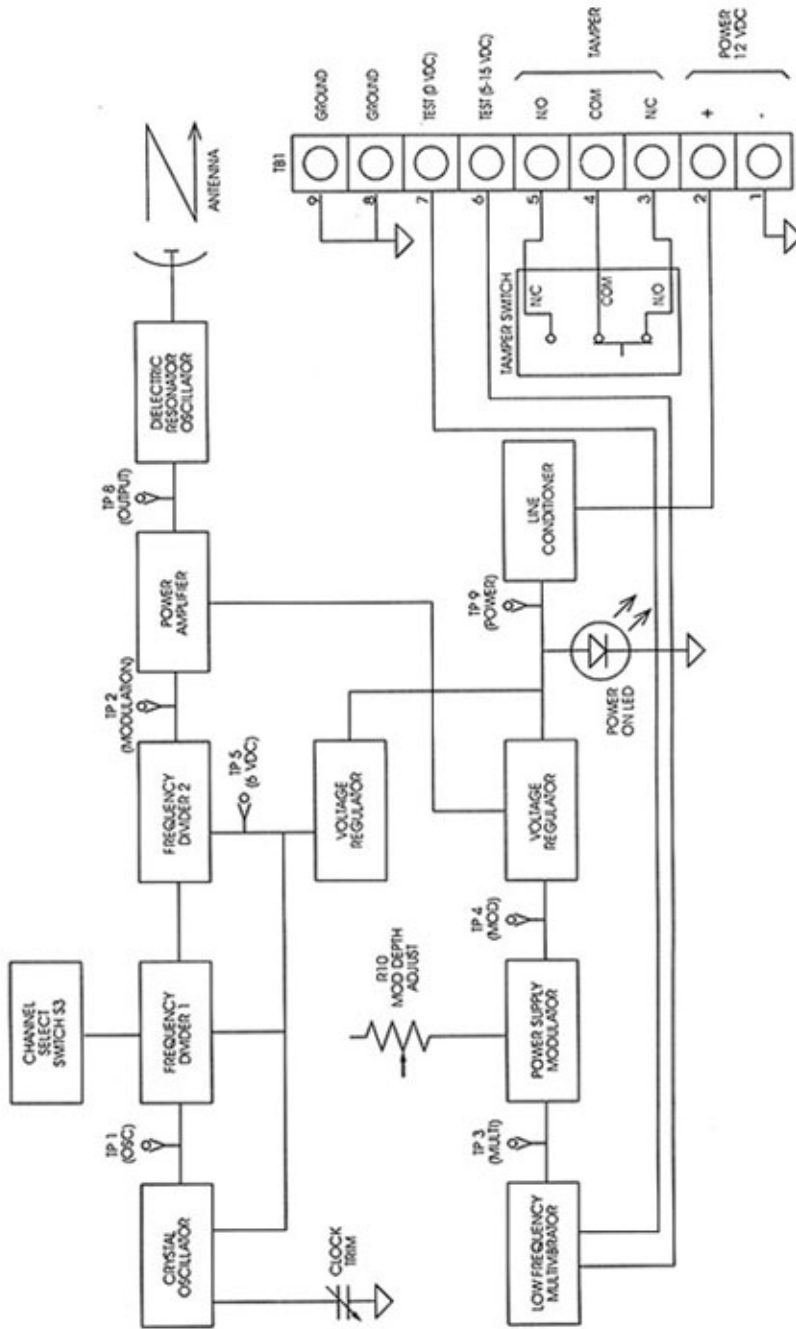

Figure 14: Transmitter Block Diagram

Receiver

Here is a functional block diagram of the receiver unit for the model 24000.

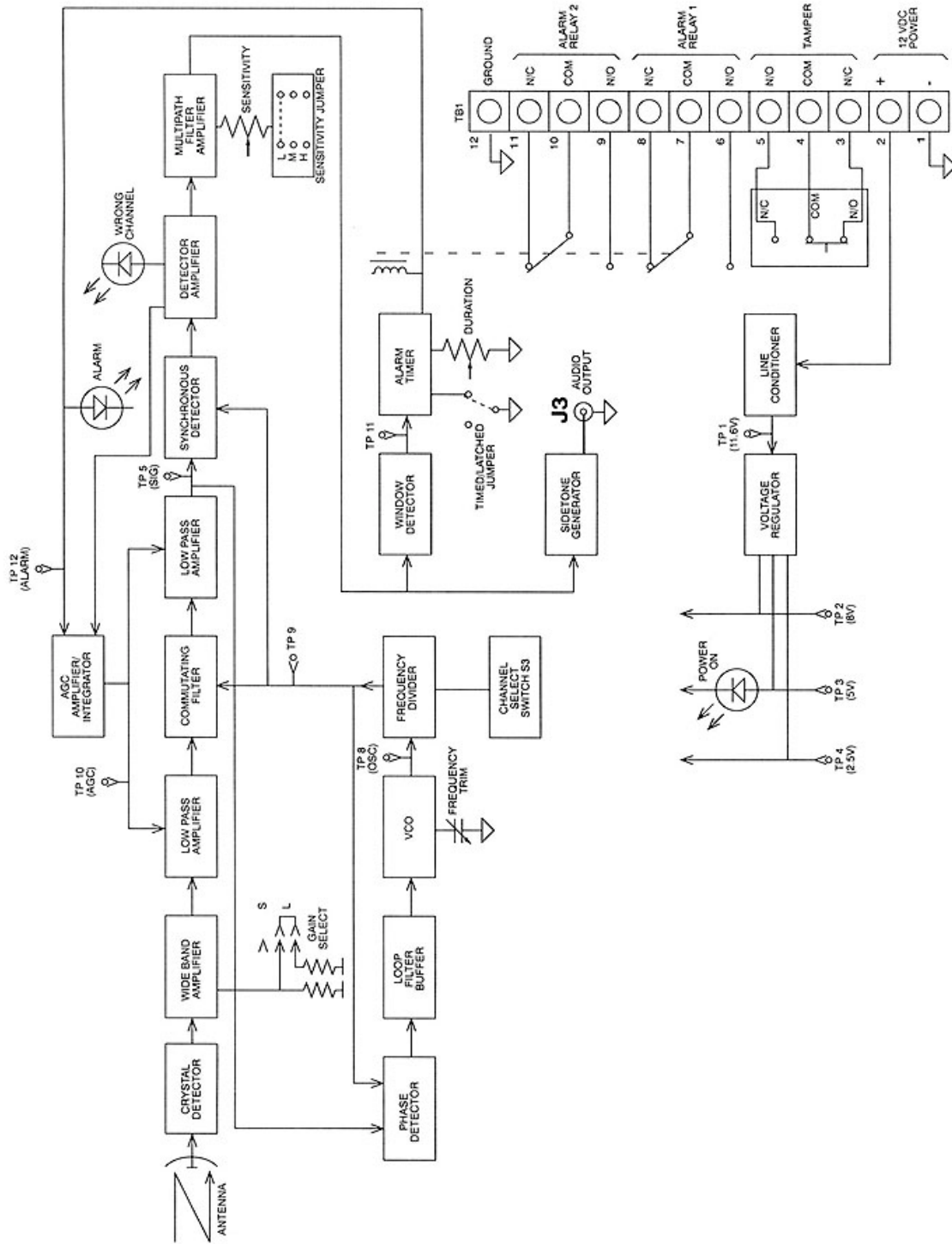

Figure 15: Receiver Block Diagram

TROUBLESHOOTING

The following are procedures for troubleshooting the system. If, after checking out these conditions, you find your system is still not functioning, then the possibility of a faulty condition on another system on the premises beside the PPI 24000 System is very likely.

Nuisance Alarms

Nuisance alarms are usually attributed to physical problems within the detection zone. Refer to the SITE PREPARATION section of the manual and review those conditions inherent to causing nuisance alarms. If these alarms persist, note time and conditions of each alarm. Is there a physical feature of your detection zone that occurs at certain times, i.e., traffic or train going by, etc.?

Continuous Alarms

Continuous alarms are more apt to be an equipment-related problem than a detection zone problem. First, determine if the sensor system is aligned and adjusted for appropriate sensitivity. Refer to the OPERATING INSTRUCTIONS section of the manual and review those conditions causing continuous alarms. Check to make sure the alarm relay latch-timed jumper is in the “Timed”(T) position. Remove external wires from the receiver unit circuit board Terminal 6 or 8, and measure ohms on relay contact. Then proceed to the BOARD LEVEL TEST POINTS section and test the transmitter/receiver circuit boards.

An “alarm” situation may also occur if power to the system is being interrupted. Check both the primary power source and all terminal connections for the DC power.

No Alarm

For a “no alarm” situation, check the alarm relay to verify it is working. Remove external wires from the receiver unit circuit board Terminal 6 or 8, and measure ohms on relay contact. Also check the receiver circuit board with the test points listed in the BOARD LEVEL TEST POINTS section.

TEST POINTS

The board containing the electronic circuitry in the transmitter/receiver unit electronic enclosures may be tested for readings required for normal operation of the system Figures 12 and 13 show the location of the test points on the boards. This test should be done under the following conditions:

- 1 12 VDC (nominal) power applied to both transmitter and receiver units.
- 2 The same channel selection for both transmitter and receiver units
- 3 Mechanical (transmitter to receiver) alignment complete
- 4 Obtain “normal indications” for each test/observation before proceeding to the next test point.

- 5 All measurements require a digital multimeter (DMM) except where an oscilloscope reading is indicated.

BOARD LEVEL TEST POINTS

TEST POINT OBSERVATION	NORMAL INDICATION	CAUSE FOR ABNORMAL READING
TRANSMITTER		
TP-9	11.60 ± 0.25VDC (with 12.0VDC in)	1. Fuse F1 blown 2. No power to TB-1 terminal 1(-) and 2(+), 11 - 15.0VDC 3. No power to RFI filter
"POWER" LED (DS-1)	Illuminated	1. LED open
TP-5	6.0 ± 0.5VDC	1. Voltage regulator U11 faulty
TP-8	5 - 8V P-P oscilloscope reading clean and symmetrical square wave	1. Power amplifier faulty 2. Code generator faulty
RECEIVER		
TP-1	11.60 ± 0.25VDC (with 12.0VDC in)	1. Fuse F1 blown 2. No power to TB-1 terminal 1(-) and 2(+), 11 - 15.0VDC 3. No power to RFI filter
TP-3	5.0VDC ± 0.1VDC	1. Regulator U15 failure 2. DS-3 "power" LED open
TP-2	8.0VDC ± 0.1VDC	1. Regulator U15 failure
TP-4	2.5VDC ± 0.1VDC	1. Zener diode D9 failure
TP-10	1.70 to 7.3VDC	1. Channel selection not correct 2. Mechanical alignment improper 3. Transmitter not operating properly 4. Receiver circuits faulty
"ALARM" LED (DS-2)	Non-Illuminated	1. Channel selection not correct 2. Mechanical alignment improper 3. Transmitter not operating properly 4. Receiver circuits faulty
"WRONG CHANNEL" LED (DS-1)	Non-Illuminated	1. Channel selection at TX/RX not identical 2. Object in path 3. Faulty transmitter 4. Faulty receiver

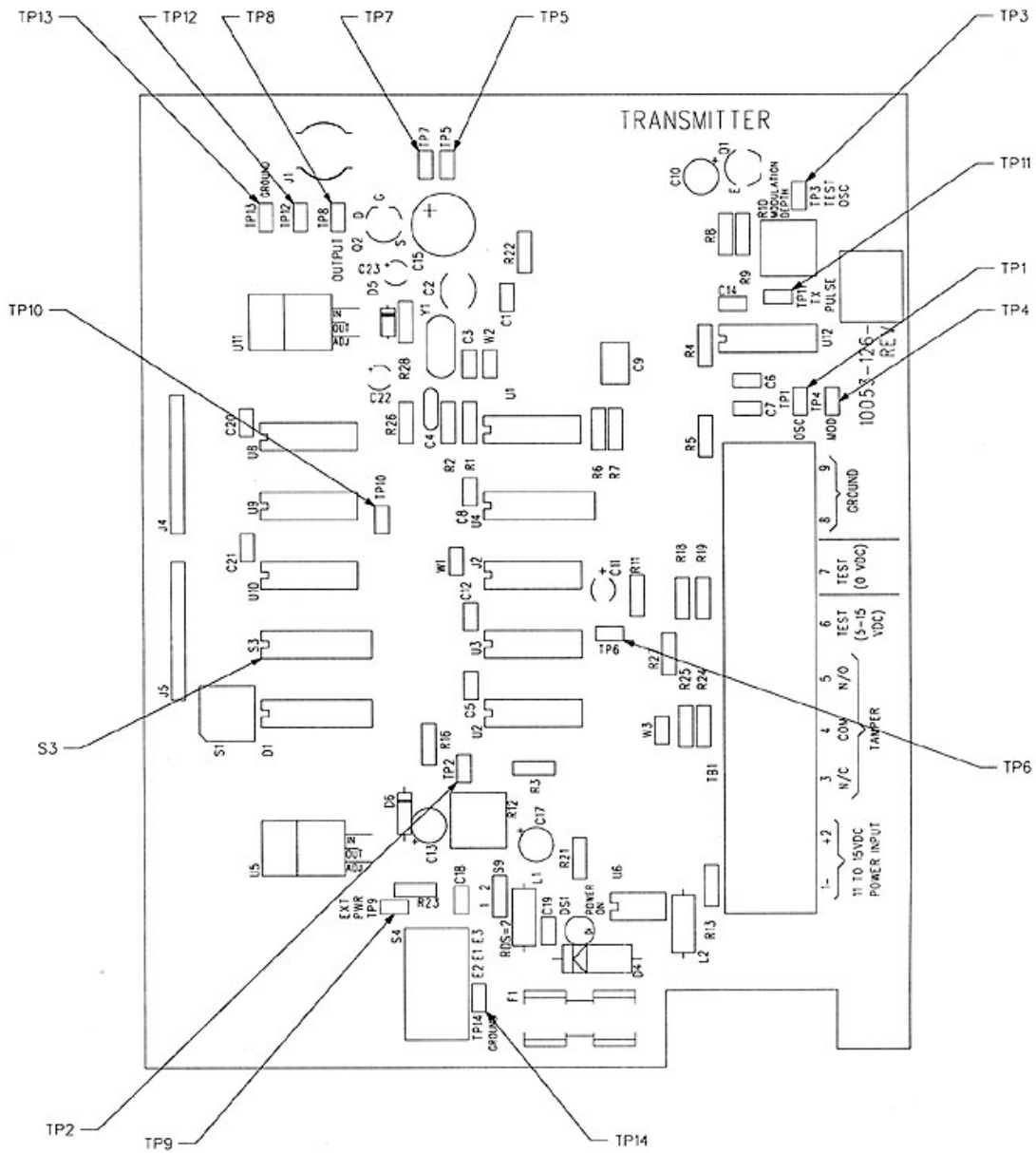

Figure 16: Transmitter Circuit Board Component Location

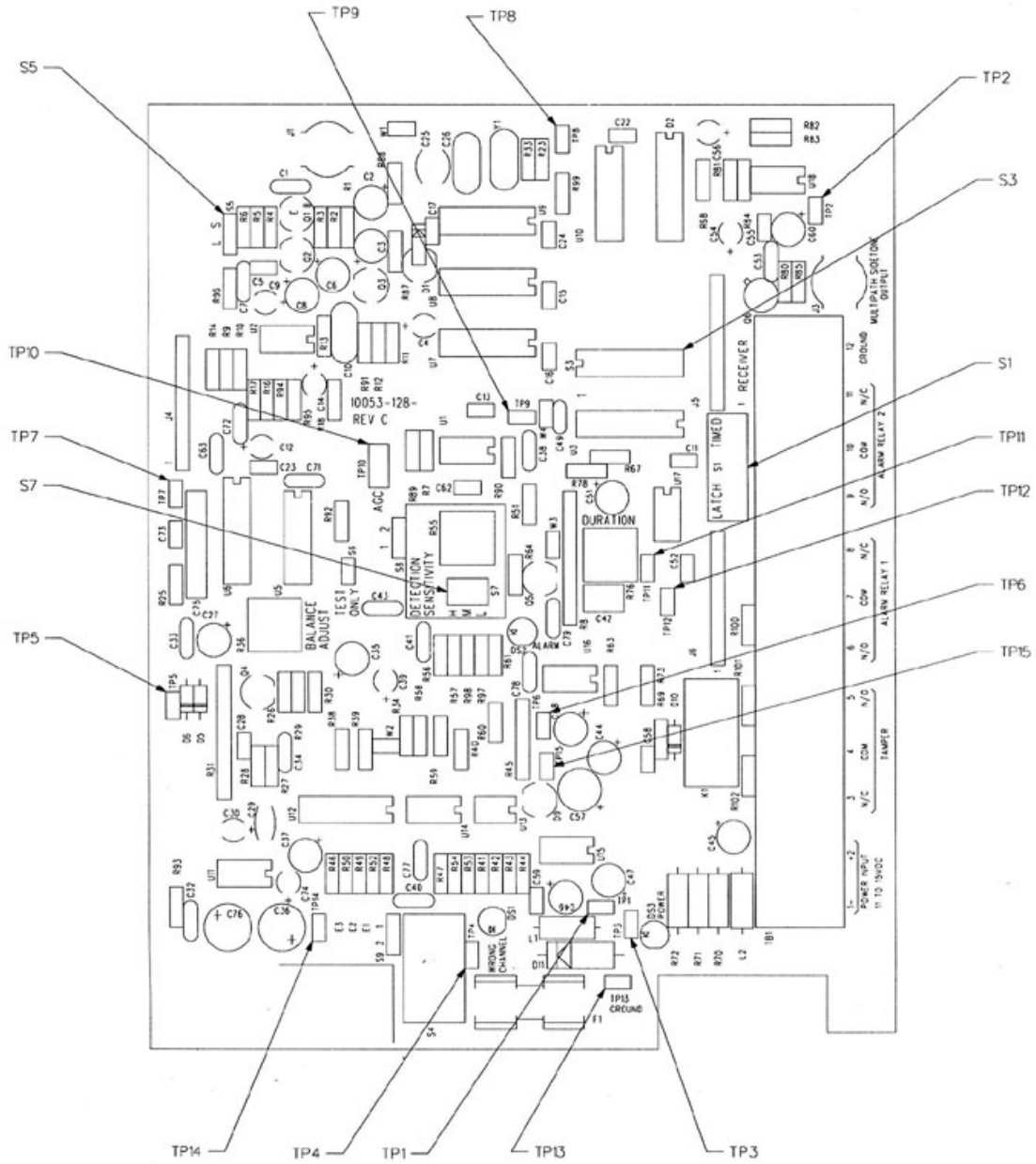

Figure 17: Receiver Circuit Board Component Location