



A D T

# FCC TEST REPORT (15.247) (WLAN)

**REPORT NO.:** RF981005A05

**MODEL NO.:** T7Mxxxxxx

– multiple listing see item 3.1

**RECEIVED:** Oct. 5, 2009

**TESTED:** Nov. 10 ~ 23, 2009

**ISSUED:** March 30, 2010

**APPLICANT:** TWINHEAD INTERNATIONAL CORP.

**ADDRESS:** 10F, No. 550, Rueiguang Rd., Neihu Chiu,  
Taipei, Taiwan 114, R.O.C.

**ISSUED BY:** Bureau Veritas Consumer Products Services  
(H.K.) Ltd., Taoyuan Branch

**LAB LOCATION:** No. 47, 14th Ling, Chia Pau Tsuen, Lin Kou  
Hsiang, Taipei Hsien, 244 Taiwan

This test report consists of 120 pages in total. It may be duplicated completely for legal use with the approval of the applicant. It should not be reproduced except in full, without the written approval of our laboratory. The client should not use it to claim product endorsement by TAF or any government agencies. The test results in the report only apply to the tested sample.





A D T

## TABLE OF CONTENTS

1.	CERTIFICATION.....	5
2.	SUMMARY OF TEST RESULTS .....	6
2.1	MEASUREMENT UNCERTAINTY .....	6
3.	GENERAL INFORMATION .....	7
3.1	GENERAL DESCRIPTION OF EUT .....	7
3.2	DESCRIPTION OF TEST MODES .....	10
3.2.1	CONFIGURATION OF SYSTEM UNDER TEST .....	11
3.2.2	TEST MODE APPLICABILITY AND TESTED CHANNEL DETAIL.....	12
3.3	GENERAL DESCRIPTION OF APPLIED STANDARDS .....	16
3.4	DESCRIPTION OF SUPPORT UNITS.....	16
4.	TEST TYPES AND RESULTS (FOR 2.4GHz BAND).....	17
4.1	RADIATED EMISSION MEASUREMENT.....	17
4.1.1	LIMITS OF RADIATED EMISSION MEASUREMENT .....	17
4.1.2	TEST INSTRUMENTS .....	18
4.1.3	TEST PROCEDURES .....	19
4.1.4	DEVIATION FROM TEST STANDARD .....	19
4.1.5	TEST SETUP .....	20
4.1.6	EUT OPERATING CONDITIONS.....	20
4.1.7	TEST RESULTS .....	21
4.2	CONDUCTED EMISSION MEASUREMENT.....	35
4.2.1	LIMITS OF CONDUCTED EMISSION MEASUREMENT .....	35
4.2.2	TEST INSTRUMENTS .....	35
4.2.3	TEST PROCEDURES .....	36
4.2.4	DEVIATION FROM TEST STANDARD .....	36
4.2.5	TEST SETUP .....	37
4.2.6	EUT OPERATING CONDITIONS.....	37
4.2.7	TEST RESULTS .....	38
4.3	6DB BANDWIDTH MEASUREMENT .....	40
4.3.1	LIMITS OF 6DB BANDWIDTH MEASUREMENT .....	40
4.3.2	TEST INSTRUMENTS .....	40
4.3.3	TEST PROCEDURE .....	40
4.3.4	DEVIATION FROM TEST STANDARD .....	40
4.3.5	TEST SETUP .....	41
4.3.6	EUT OPERATING CONDITIONS.....	41
4.3.7	TEST RESULTS .....	42
4.4	MAXIMUM OUTPUT POWER .....	46
4.4.1	LIMITS OF MAXIMUM PEAK OUTPUT POWER MEASUREMENT .....	46
4.4.2	INSTRUMENTS .....	46
4.4.3	TEST PROCEDURES .....	46
4.4.4	DEVIATION FROM TEST STANDARD .....	47
4.4.5	TEST SETUP .....	47
4.4.6	EUT OPERATING CONDITIONS.....	47



4.4.7	TEST RESULTS .....	48
4.5	POWER SPECTRAL DENSITY MEASUREMENT .....	50
4.5.1	LIMITS OF POWER SPECTRAL DENSITY MEASUREMENT .....	50
4.5.2	TEST INSTRUMENTS .....	50
4.5.3	TEST PROCEDURE .....	50
4.5.4	DEVIATION FROM TEST STANDARD .....	51
4.5.5	TEST SETUP .....	51
4.5.6	EUT OPERATING CONDITION .....	51
4.5.7	TEST RESULTS .....	52
4.6	BAND EDGES MEASUREMENT .....	56
4.6.1	LIMITS OF BAND EDGES MEASUREMENT .....	56
4.6.2	TEST INSTRUMENTS .....	56
4.6.3	TEST PROCEDURE .....	57
4.6.4	DEVIATION FROM TEST STANDARD .....	57
4.6.5	EUT OPERATING CONDITION .....	57
4.6.6	TEST RESULTS .....	58
5.	TEST TYPES AND RESULTS (FOR 5.0GHz BAND) .....	74
5.1	RADIATED EMISSION MEASUREMENT .....	74
5.1.1	LIMITS OF RADIATED EMISSION MEASUREMENT .....	74
5.1.2	TEST INSTRUMENTS .....	75
5.1.3	TEST PROCEDURES .....	76
5.1.4	DEVIATION FROM TEST STANDARD .....	76
5.1.5	TEST SETUP .....	77
5.1.6	EUT OPERATING CONDITIONS .....	77
5.1.7	TEST RESULTS .....	78
5.2	CONDUCTED EMISSION MEASUREMENT .....	88
5.2.1	LIMITS OF CONDUCTED EMISSION MEASUREMENT .....	88
5.2.2	TEST INSTRUMENTS .....	88
5.2.3	TEST PROCEDURES .....	89
5.2.4	DEVIATION FROM TEST STANDARD .....	89
5.2.5	TEST SETUP .....	90
5.2.6	EUT OPERATING CONDITIONS .....	90
5.2.7	TEST RESULTS .....	91
5.3	6DB BANDWIDTH MEASUREMENT .....	93
5.3.1	LIMITS OF 6DB BANDWIDTH MEASUREMENT .....	93
5.3.2	TEST INSTRUMENTS .....	93
5.3.3	TEST PROCEDURE .....	93
5.3.4	DEVIATION FROM TEST STANDARD .....	94
5.3.5	TEST SETUP .....	94
5.3.6	EUT OPERATING CONDITIONS .....	94
5.3.7	TEST RESULTS .....	95
5.4	MAXIMUM OUTPUT POWER .....	98
5.4.1	LIMITS OF MAXIMUM OUTPUT POWER MEASUREMENT .....	98
5.4.2	INSTRUMENTS .....	98
5.4.3	TEST PROCEDURES .....	98



5.4.4	DEVIATION FROM TEST STANDARD .....	99
5.4.5	TEST SETUP .....	99
5.4.6	EUT OPERATING CONDITIONS.....	99
5.4.7	TEST RESULTS .....	100
5.5	POWER SPECTRAL DENSITY MEASUREMENT .....	101
5.5.1	LIMITS OF POWER SPECTRAL DENSITY MEASUREMENT .....	101
5.5.2	TEST INSTRUMENTS .....	101
5.5.3	TEST PROCEDURE .....	101
5.5.4	DEVIATION FROM TEST STANDARD .....	102
5.5.5	TEST SETUP .....	102
5.5.6	EUT OPERATING CONDITION.....	102
5.5.7	TEST RESULTS .....	103
5.6	BAND EDGES MEASUREMENT.....	106
5.6.1	LIMITS OF BAND EDGES MEASUREMENT .....	106
5.6.2	TEST INSTRUMENTS .....	106
5.6.3	TEST PROCEDURE .....	107
5.6.4	DEVIATION FROM TEST STANDARD .....	108
5.6.5	EUT OPERATING CONDITION.....	108
5.6.6	TEST RESULTS .....	108
6.	PHOTOGRAPHS OF THE TEST CONFIGURATION .....	118
7.	INFORMATION ON THE TESTING LABORATORIES.....	119
8.	APPENDIX A - MODIFICATIONS RECORDERS FOR ENGINEERING CHANGES TO THE EUT BY THE LAB .....	120



A D T

## 1. CERTIFICATION

**PRODUCT:** Tablet PC

**BRAND NAME:** DURABOOK, TabletKiosk, MobileDemand™,  
PaceBlade, LOGIC INSTRUMENT

**MODEL NO.:** T7Mxxxxxx – multiple listing see item 3.1

**APPLICANT:** TWINHEAD INTERNATIONAL CORP.

**TEST SAMPLE:** R&D SAMPLE

**TESTED:** Nov. 10 ~ 23, 2009

**STANDARDS:** FCC Part 15, Subpart C (Section 15.247)

ANSI C63.4-2003

The above equipment (Model: T7MD1) has been tested by **Bureau Veritas Consumer Products Services (H.K.) Ltd., Taoyuan Branch**, and found compliance with the requirement of the above standards. The test record, data evaluation & Equipment Under Test (EUT) configurations represented herein are true and accurate accounts of the measurements of the sample's EMC characteristics under the conditions specified in this report.

**PREPARED BY :** Annie Chang , **DATE:** March 30, 2010  
( Annie Chang / Senior Specialist )

**TECHNICAL ACCEPTANCE :** Jamison Chan , **DATE:** March 30, 2010  
Responsible for RF ( Jamison Chan / Supervisor )

**APPROVED BY :** Ken Liu , **DATE:** March 30, 2010  
( Ken Liu / Assistant Manager )



## 2. SUMMARY OF TEST RESULTS

The EUT has been tested according to the following specifications:

APPLIED STANDARD: FCC PART 15, SUBPART C (SECTION 15.247)			
STANDARD SECTION	TEST TYPE AND LIMIT	RESULT	REMARK
15.207	AC Power Conducted Emission	PASS	Meet the requirement of limit. Minimum passing margin is -13.33dB at 0.678MHz
15.247(a)(2)	Spectrum Bandwidth of a Direct Sequence Spread Spectrum System Limit: min. 500kHz	PASS	Meet the requirement of limit.
15.247(b)	Maximum Peak Output Power Limit: max. 30dBm	PASS	Meet the requirement of limit.
15.247(d)	Radiated Emissions Limit: Table 15.209	PASS	Meet the requirement of limit. Minimum passing margin is -0.1dB at 2390.00MHz, 11490MHz, 11570MHz & 11650MHz
15.247(e)	Power Spectral Density Limit: max. 8dBm	PASS	Meet the requirement of limit.
15.247(d)	Band Edge Measurement Limit: 20dB less than the peak value of fundamental frequency	PASS	Meet the requirement of limit.
15.203	Antenna Requirement	PASS	Antenna connector is U.FL not a standard connector.

### 2.1 MEASUREMENT UNCERTAINTY

Where relevant, the following measurement uncertainty levels have been estimated for tests performed on the EUT as specified in CISPR 16-4-2:

This uncertainty represents an expanded uncertainty expressed at approximately the 95% confidence level using a coverage factor of  $k = 2$ .

MEASUREMENT	FREQUENCY	UNCERTAINTY
Conducted emissions	150kHz~30MHz	2.44 dB
Radiated emissions	30MHz~1GHz	3.86 dB
	Above 1GHz	2.89 dB



A D T

### 3. GENERAL INFORMATION

#### 3.1 GENERAL DESCRIPTION OF EUT

<b>PRODUCT</b>	Tablet PC
<b>MODEL NO.</b>	T7Mxxxxxx – multiple listing see below
<b>FCC ID</b>	FKGT7M
<b>POWER SUPPLY</b>	19Vdc from AC adapter or 7.4Vdc from Battery
<b>MODULATION TYPE</b>	CCK, DQPSK, DBPSK for DSSS 64QAM, 16QAM, QPSK, BPSK for OFDM
<b>MODULATION TECHNOLOGY</b>	DSSS, OFDM
<b>TRANSFER RATE</b>	802.11b:11.0/ 5.5/ 2.0/ 1.0Mbps 802.11g: 54.0/ 48.0/ 36.0/ 24.0/ 18.0/ 12.0/ 9.0/ 6.0Mbps 802.11a: 54.0/ 48.0/ 36.0/ 24.0/ 18.0/ 12.0/ 9.0/ 6.0Mbps 802.11n: up to 300.0Mbps
<b>OPERATING FREQUENCY</b>	2.4GHz: 2412 ~ 2462MHz 5.0GHz: 5745 ~ 5825MHz
<b>NUMBER OF CHANNEL</b>	2.4GHz: 11 for 802.11b, 802.11g, 802.11n (20MHz) 7 for 802.11n (40MHz) 5.0GHz: 5 for 802.11a, 802.11n (20MHz) 2 for 802.11n (40MHz)
<b>OUTPUT POWER</b>	275.4mW for 2.4GHz 195.0mW for 5.0GHz
<b>ANTENNA TYPE</b>	<b>2.4GHz:</b> PIFA antenna with 1.01dBi gain <b>5.0GHz:</b> PIFA antenna with 2.87dBi gain
<b>ANTENNA CONNECTOR</b>	Antenna connector is U.FL not a standard connector.
<b>DATA CABLE</b>	NA
<b>I/O PORTS</b>	Refer to user's manual
<b>ASSOCIATED DEVICES</b>	Refer to note below



A D T

**Note:**

1. The EUT is a Tablet PC, the functions of EUT listed as below:

Function	Test Standard	Reference Report
<b>WLAN IEEE802.11abgn Mini-PCI Card</b> (Brand: Intel, Model: 512AN)	<b>WLAN 802.11bgn</b> <b>WLAN 802.11an</b> (5745~5825 MHz)	FCC Part 15, Subpart C (Section 15.247)
	<b>WLAN 802.11an</b> (5180~5320MHz, 5500~5700MHz)	FCC Part 15, Subpart E (Section 15.407)
	<b>WLAN 802.11a</b> (For DFS report) (Model: T7MD1) (5260~5320MHz, 5500~5700MHz)	FCC Part 15, Subpart E (Section 15.407)
	<b>WLAN 802.11a</b> (For DFS report) (Model: T7MK1) (5260~5320MHz, 5500~5700MHz)	FCC Part 15, Subpart E (Section 15.407)
	<b>WLAN 802.11a</b> (For DFS report) (Model: T7ML1) (5260~5320MHz, 5500~5700MHz)	FCC Part 15, Subpart E (Section 15.407)
	<b>Bluetooth module</b> (Brand: Billionton, Model: GUBTCR42M)	FCC Part 15, Subpart C (Section 15.247)
<b>RFID</b> (Brand: Microprogram, Model: R-07050S1S8)	FCC Part 15, Subpart C (Section 15.225)	

2. The EUT has several models, which are identical to each other except for their brand name differences only, as the following:

BRAND	MODEL NO.	DESCRIPTION
DURABOOK	T7Mxxxxxx ("x" = 0~9, A~Z or blank)	For marketing different
TabletKiosk	a72xxxx ("x" = 0~9, A~Z or blank)	
MobileDemand™	xTablet® T7000XXXX ("x" = 0~9, A~Z or blank)	
PaceBlade	Pacebook RD7 series	
LOGIC INSTRUMENT	FIELDBOOK	

During the test, the **model no.: T7MD1** was selected as the representative model and only its test data was recorded in this report.

The Model: T7Mxxxxxx has three samples, which are identical to each other except for their interface differences only, as the below:

MODEL NO.	T7MD1	T7MK1	T7ML1
<b>INTERFACE DESCRIPTION</b>	USB x2 DB9 Card Reader (Express card & SD Card)	Audio x2 (Microphone & headphone) USB x2 RJ-45 Card Reader (Express card & SD Card)	Audio x2 (Microphone & headphone) USB x2 RJ-45 Card Reader (PCMCIA & SD Card)

The above three samples were tested, during the test, the **model no.: T7MD1** was the worst case and only its test data was recorded in this report.



3. The frequency bands used in this EUT are listed as follows:

Frequency Band (MHz)	2412~2462	5180~5320	5500~5700	5745~5825
802.11b	√			
802.11g	√			
802.11a		√	√	√
802.11n (20MHz)	√	√	√	√
802.11n (40MHz)	√	√	√	√

4. The EUT incorporates a SIMO function. Physically, the EUT provides one completed transmitter and two receivers.

MODULATION MODE	TX FUNCTION
802.11b	1TX
802.11g	1TX
802.11a	1TX
802.11n (20MHz)	1TX
802.11n (40MHz)	1TX

5. The EUT consumes power from an AC adapter or battery, as follows:

BRAND	MODEL NO.	SPEC.
FSP	FSP065-RAB	AC I/P: 100-240V, 1.5A, 50-60Hz DC O/P: 19V, 3.42A Non-shielded AC 3-pin (1.8m) Non-shielded DC (1.8m) with one ferrite core
FSP	T7M	7.4Vdc 2580mAh

6. The above EUT information was declared by manufacturer and for more detailed features description, please refer to the manufacturer's specifications or user's manual.



### 3.2 DESCRIPTION OF TEST MODES

#### FOR 2.4GHz:

11 channels are provided for 802.11b, 802.11g and 802.11n (20MHz):

CHANNEL	FREQUENCY	CHANNEL	FREQUENCY
1	2412MHz	7	2442MHz
2	2417MHz	8	2447MHz
3	2422MHz	9	2452MHz
4	2427MHz	10	2457MHz
5	2432MHz	11	2462MHz
6	2437MHz		

7 channels are provided for 802.11n (40MHz):

CHANNEL	FREQUENCY	CHANNEL	FREQUENCY
1	2422MHz	5	2442MHz
2	2427MHz	6	2447MHz
3	2432MHz	7	2452MHz
4	2437MHz		

#### FOR 5.0GHz (5745 ~ 5825MHz):

5 channels are provided for 802.11a and 802.11n (20MHz):

CHANNEL	FREQUENCY	CHANNEL	FREQUENCY
149	5745MHz	161	5805MHz
153	5765MHz	165	5825MHz
157	5785MHz		

2 channels are provided for 802.11n (40MHz):

CHANNEL	FREQUENCY	CHANNEL	FREQUENCY
151	5755MHz	159	5795MHz

### 3.2.1 CONFIGURATION OF SYSTEM UNDER TEST

#### Mode A:

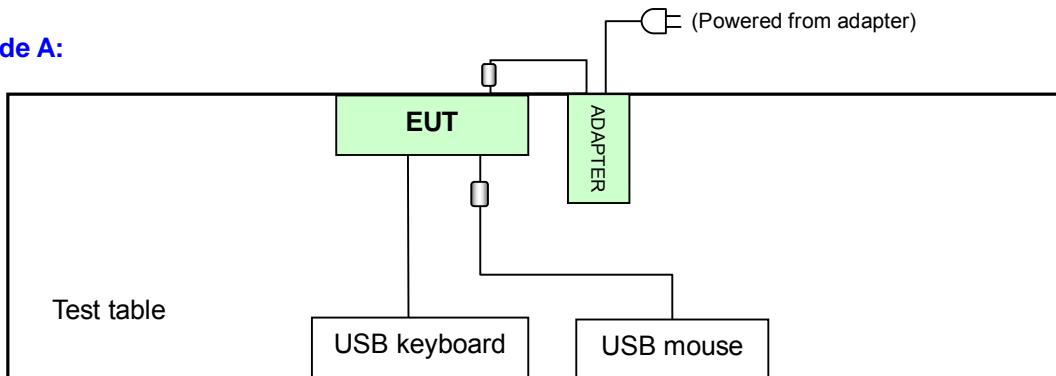

#### Mode B:

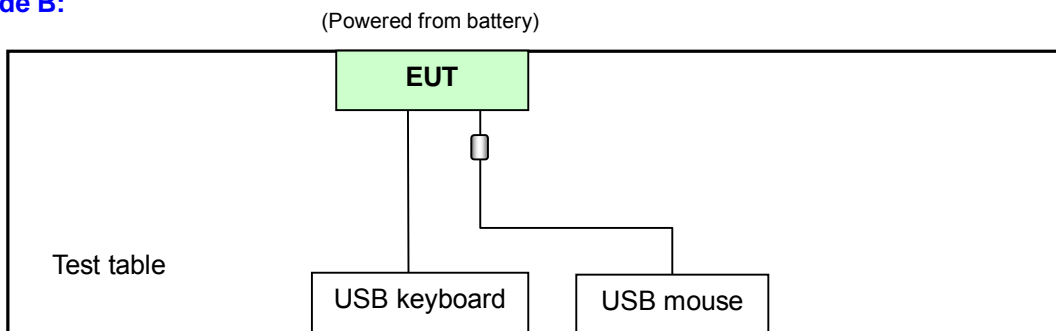



A D T

### 3.2.2 TEST MODE APPLICABILITY AND TESTED CHANNEL DETAIL

FOR 2.400 ~ 2.4835GHz:

EUT CONFIGURE MODE	APPLICABLE TO				DESCRIPTION
	RE <sup>3</sup> 1G	RE<1G	PLC	APCM	
A	√	√	√	√	EUT w. AC adapter
B	-	√	-	-	EUT w. Battery

Where **RE<sup>3</sup>1G**: Radiated Emission above 1GHz      **RE<1G**: Radiated Emission below 1GHz  
**PLC**: Power Line Conducted Emission      **APCM**: Antenna Port Conducted Measurement

#### RADIATED EMISSION TEST (ABOVE 1GHz):

- Pre-Scan has been conducted to determine the worst-case mode from all possible combinations between available modulations, data rates, XYZ axis and antenna ports (if EUT with antenna diversity architecture).
- Following channel(s) was (were) selected for the final test as listed below.

EUT CONFIGURE MODE	MODE	AVAILABLE CHANNEL	TESTED CHANNEL	MODULATION TECHNOLOGY	MODULATION TYPE	DATA RATE (Mbps)	AXIS
A	802.11b	1 to 11	1, 6, 11	DSSS	DBPSK	1.0	X
A	802.11g	1 to 11	1, 6, 11	OFDM	BPSK	6.0	X
A	802.11n (20MHz)	1 to 11	1, 6, 11	OFDM	BPSK	6.5	X
A	802.11n (40MHz)	1 to 7	1, 4, 7	OFDM	BPSK	13.5	X

#### RADIATED EMISSION TEST (BELOW 1GHz):

- Pre-Scan has been conducted to determine the worst-case mode from all possible combinations between available modulations, data rates, XYZ axis and antenna ports (if EUT with antenna diversity architecture).
- Following channel(s) was (were) selected for the final test as listed below.

EUT CONFIGURE MODE	MODE	AVAILABLE CHANNEL	TESTED CHANNEL	MODULATION TECHNOLOGY	MODULATION TYPE	DATA RATE (Mbps)	AXIS
A & B	802.11n (20MHz)	1 to 11	11	OFDM	BPSK	6.5	X

#### POWER LINE CONDUCTED EMISSION TEST:

- Pre-Scan has been conducted to determine the worst-case mode from all possible combinations between available modulations, data rates and antenna ports (if EUT with antenna diversity architecture).
- Following channel(s) was (were) selected for the final test as listed below.

EUT CONFIGURE MODE	MODE	AVAILABLE CHANNEL	TESTED CHANNEL	MODULATION TECHNOLOGY	MODULATION TYPE	DATA RATE (Mbps)
A	802.11n (20MHz)	1 to 11	11	OFDM	BPSK	6.5



**BANDEDGE MEASUREMENT:**

- Pre-Scan has been conducted to determine the worst-case mode from all possible combinations between available modulations, data rates, XYZ axis and antenna ports (if EUT with antenna diversity architecture).
- Following channel(s) was (were) selected for the final test as listed below.

EUT CONFIGURE MODE	MODE	AVAILABLE CHANNEL	TESTED CHANNEL	MODULATION TECHNOLOGY	MODULATION TYPE	DATA RATE (Mbps)	AXIS
A	802.11b	1 to 11	1, 11	DSSS	DBPSK	1.0	X
A	802.11g	1 to 11	1, 11	OFDM	BPSK	6.0	X
A	802.11n (20MHz)	1 to 11	1, 11	OFDM	BPSK	6.5	X
A	802.11n (40MHz)	1 to 7	1, 7	OFDM	BPSK	13.5	X

**ANTENNA PORT CONDUCTED MEASUREMENT:**

- This item includes all test value of each mode, but only includes spectrum plot of worst value of each mode.
- Pre-Scan has been conducted to determine the worst-case mode from all possible combinations between available modulations, data rates and antenna ports (if EUT with antenna diversity architecture).
- Following channel(s) was (were) selected for the final test as listed below.

EUT CONFIGURE MODE	MODE	AVAILABLE CHANNEL	TESTED CHANNEL	MODULATION TECHNOLOGY	MODULATION TYPE	DATA RATE (Mbps)
A	802.11b	1 to 11	1, 6, 11	DSSS	DBPSK	1.0
A	802.11g	1 to 11	1, 6, 11	OFDM	BPSK	6.0
A	802.11n (20MHz)	1 to 11	1, 6, 11	OFDM	BPSK	6.5
A	802.11n (40MHz)	1 to 7	1, 4, 7	OFDM	BPSK	13.5

**TEST CONDITION:**

APPLICABLE TO	EUT CONFIGURE MODE	ENVIRONMENTAL CONDITIONS	INPUT POWER	TESTED BY
RE <sup>3</sup> 1G	A	23deg. C, 82% RH, 1005hPa	120Vac, 60Hz	Nick Chen
RE <1G	A	23deg. C, 83% RH, 1013hPa	120Vac, 60Hz	Nick Chen
	B	23deg. C, 83% RH, 1013hPa	7.4Vdc	Nick Chen
PLC	A	20deg. C, 85% RH, 1020hPa	120Vac, 60Hz	Nick Chen
APCM	A	23deg. C, 70% RH, 1020hPa	120Vac, 60Hz	Nick Chen



A D T

**FOR 5.745 ~ 5.825GHz:**

EUT CONFIGURE MODE	APPLICABLE TO				DESCRIPTION
	PLC	RE<1G	RE <sup>≥</sup> 1G	APCM	
A	√	√	√	√	EUT w. AC adapter
B	-	√	-	-	EUT w. Batteries

Where **PLC**: Power Line Conducted Emission      **RE<1G**: Radiated Emission below 1GHz  
**RE<sup>≥</sup>1G**: Radiated Emission above 1GHz      **APCM**: Antenna Port Conducted Measurement

**RADIATED EMISSION TEST (ABOVE 1GHz):**

- Pre-Scan has been conducted to determine the worst-case mode from all possible combinations between available modulations, data rates, XYZ axis and antenna ports (if EUT with antenna diversity architecture).
- Following channel(s) was (were) selected for the final test as listed below.

EUT CONFIGURE MODE	MODE	AVAILABLE CHANNEL	TESTED CHANNEL	MODULATION TECHNOLOGY	MODULATION TYPE	DATA RATE (Mbps)	AXIS
A	802.11a	149 to 165	149, 157, 165	OFDM	BPSK	6.0	X
A	802.11n (20MHz)	149 to 165	149, 157, 165	OFDM	BPSK	6.5	X
A	802.11n (40MHz)	151 to 159	151, 159	OFDM	BPSK	13.5	X

**RADIATED EMISSION TEST (BELOW 1GHz):**

- Pre-Scan has been conducted to determine the worst-case mode from all possible combinations between available modulations, data rates, XYZ axis and antenna ports (if EUT with antenna diversity architecture).
- Following channel(s) was (were) selected for the final test as listed below.

EUT CONFIGURE MODE	MODE	AVAILABLE CHANNEL	TESTED CHANNEL	MODULATION TECHNOLOGY	MODULATION TYPE	DATA RATE (Mbps)	AXIS
A & B	802.11n (20MHz)	149 to 165	165	OFDM	BPSK	6.5	X

**POWER LINE CONDUCTED EMISSION TEST:**

- Pre-Scan has been conducted to determine the worst-case mode from all possible combinations between available modulations, data rates and antenna ports (if EUT with antenna diversity architecture).
- Following channel(s) was (were) selected for the final test as listed below.

EUT CONFIGURE MODE	MODE	AVAILABLE CHANNEL	TESTED CHANNEL	MODULATION TECHNOLOGY	MODULATION TYPE	DATA RATE (Mbps)
A	802.11n (20MHz)	149 to 165	165	OFDM	BPSK	6.5



**BANDEDGE MEASUREMENT:**

- Pre-Scan has been conducted to determine the worst-case mode from all possible combinations between available modulations, data rates, XYZ axis and antenna ports (if EUT with antenna diversity architecture).
- Following channel(s) was (were) selected for the final test as listed below.

EUT CONFIGURE MODE	MODE	AVAILABLE CHANNEL	TESTED CHANNEL	MODULATION TECHNOLOGY	MODULATION TYPE	DATA RATE (Mbps)
A	802.11a	149 to 165	149, 165	OFDM	BPSK	6.0
A	802.11n (20MHz)	149 to 165	149, 165	OFDM	BPSK	6.5
A	802.11n (40MHz)	151 to 159	151, 159	OFDM	BPSK	13.5

**ANTENNA PORT CONDUCTED MEASUREMENT:**

- Pre-Scan has been conducted to determine the worst-case mode from all possible combinations between available modulations, data rates and antenna ports (if EUT with antenna diversity architecture).
- Following channel(s) was (were) selected for the final test as listed below.

EUT CONFIGURE MODE	MODE	AVAILABLE CHANNEL	TESTED CHANNEL	MODULATION TECHNOLOGY	MODULATION TYPE	DATA RATE (Mbps)
A	802.11a	149 to 165	149, 157, 165	OFDM	BPSK	6.0
A	802.11n (20MHz)	149 to 165	149, 157, 165	OFDM	BPSK	6.5
A	802.11n (40MHz)	151 to 159	151, 159	OFDM	BPSK	13.5

**TEST CONDITION:**

APPLICABLE TO	EUT CONFIGURE MODE	ENVIRONMENTAL CONDITIONS	INPUT POWER	TESTED BY
RE <sup>3</sup> 1G	A	23deg. C, 82% RH, 1005hPa	120Vac, 60Hz	Nick Chen
RE <1G	A	23deg. C, 83% RH, 1013hPa	120Vac, 60Hz	Nick Chen
	B	23deg. C, 83% RH, 1013hPa	7.4Vdc	Nick Chen
PLC	A	20deg. C, 85% RH, 1020hPa	120Vac, 60Hz	Nick Chen
APCM	A	23deg. C, 70% RH, 1020hPa	120Vac, 60Hz	Nick Chen



A D T

### 3.3 GENERAL DESCRIPTION OF APPLIED STANDARDS

The EUT is a RF Product. According to the specifications of the manufacturer, it must comply with the requirements of the following standards:

**FCC Part 15, Subpart C (15.247)**

**ANSI C63.4-2003**

All test items have been performed and recorded as per the above standards.

**NOTE:** The EUT is also considered as a kind of computer peripheral, because the connection to computer is necessary for typical use. It has been verified to comply with the requirements of FCC Part 15, Subpart B, Class B (DoC). The test report has been issued separately.

### 3.4 DESCRIPTION OF SUPPORT UNITS

The EUT has been tested as an independent unit together with other necessary accessories or support units. The following support units or accessories were used to form a representative test configuration during the tests.

NO.	PRODUCT	BRAND	MODEL NO.	SERIAL NO.	FCC ID
1	USB KEYBOARD	BTC	5200U	G09302046659	E5XKB5122U
2	USB MOUSE	MICROSOFT	X800898	9241804-30608	FCC DoC Approved

NO.	SIGNAL CABLE DESCRIPTION OF THE ABOVE SUPPORT UNITS
1	1.5 m braid shielded wire, terminated with USB connector via drain wire, w/o core.
2	1.8 m foil shielded wire, terminated with USB connector via drain wire, with 1 core.

**NOTE:** All power cords of the above support units are non-shielded (1.8m).





## 4. TEST TYPES AND RESULTS (FOR 2.4GHz BAND)

### 4.1 RADIATED EMISSION MEASUREMENT

#### 4.1.1 LIMITS OF RADIATED EMISSION MEASUREMENT

Emissions radiated outside of the specified bands, shall be according to the general radiated limits in 15.209 as following:

FREQUENCIES (MHz)	FIELD STRENGTH (microvolts/meter)	MEASUREMENT DISTANCE (meters)
0.009 ~ 0.490	2400/F(kHz)	300
0.490 ~ 1.705	24000/F(kHz)	30
1.705 ~ 30.0	30	30
30 ~ 88	100	3
88 ~ 216	150	3
216 ~ 960	200	3
Above 960	500	3

**NOTE:**

1. The lower limit shall apply at the transition frequencies.
2. Emission level (dBuV/m) = 20 log Emission level (uV/m).
3. As shown in 15.35(b), for frequencies above 1000MHz, the field strength limits are based on average detector, however, the peak field strength of any emission shall not exceed the maximum permitted average limits, specified above by more than 20dB under any condition of modulation.



A D T

## 4.1.2 TEST INSTRUMENTS

DESCRIPTION & MANUFACTURER	MODEL NO.	SERIAL NO.	CALIBRATED DATE	CALIBRATED UNTIL
HP Preamplifier	8447D	2432A03504	May 04, 2009	May 03, 2010
HP Preamplifier	8449B	3008A01924	Aug. 31, 2009	Aug. 30, 2010
HP Preamplifier	8449B	3008A01292	Aug. 10, 2009	Aug. 09, 2010
ROHDE & SCHWARZ TEST RECEIVER	ESU26	100005	Jun. 06, 2009	Jun. 05, 2010
Schwarzbeck Antenna	VULB 9168	137	Apr. 29, 2009	Apr. 28, 2010
Schwarzbeck Antenna	VHBA 9123	480	Apr. 21, 2009	Apr. 20, 2010
EMCO Horn Antenna	3115	6714	Oct. 26, 2009	Oct. 25, 2010
EMCO Horn Antenna	3115	9312-4192	Apr. 17, 2009	Apr. 16, 2010
ADT. Turn Table	TT100	0306	NA	NA
ADT. Tower	AT100	0306	NA	NA
Software	ADT_Radiated_V 7.6.15.9.2	NA	NA	NA
SUHNER RF cable	SF104-26.5	CABLE-CH6-17m -01	Aug. 20, 2009	Aug. 19, 2010
ROHDE & SCHWARZ Spectrum Analyzer	FSP 40	100036	Apr. 03, 2009	Apr. 02, 2010

- NOTE:**
1. The calibration interval of the above test instruments is 12/24 months. And the calibrations are traceable to NML/ROC and NIST/USA.
  2. The horn antenna and HP preamplifier (model: 8449B) are used only for the measurement of emission frequency above 1GHz if tested.
  3. The test was performed in Chamber No. 6.
  4. The Industry Canada Reference No. IC 7450E-6.
  5. The FCC Site Registration No. is 447212.



### 4.1.3 TEST PROCEDURES

- a. The EUT was placed on the top of a rotating table 0.8 meters above the ground at a 3 meters semi-anechoic chamber. The table was rotated 360 degrees to determine the position of the highest radiation.
- b. The EUT was set 3 meters away from the interference-receiving antenna, which was mounted on the top of a variable-height antenna tower.
- c. The height of antenna is varied from one meter to four meters above the ground to determine the maximum value of the field strength. Both horizontal and vertical polarizations of the antenna are set to make the measurement.
- d. For each suspected emission, the EUT was arranged to its worst case and then the antenna was tuned to heights from 1 meter to 4 meters and the rotatable table was turned from 0 degrees to 360 degrees to find the maximum reading.
- e. The test-receiver system was set to Peak Detect Function and Specified Bandwidth with Maximum Hold Mode.
- f. If the emission level of the EUT in peak mode was lower than the limit specified, then testing could be stopped and the peak values of the EUT would be reported. Otherwise the emissions would be re-tested one by one using peak, quasi-peak or average method as specified and then reported in a data sheet.

**NOTE:**

1. The resolution bandwidth and video bandwidth of test receiver/spectrum analyzer is 120kHz for Quasi-peak detection at frequency below 1GHz.
2. The resolution bandwidth of test receiver/spectrum analyzer is 100kHz and video bandwidth is 300kHz for Peak detection at frequency above 1GHz.
3. The resolution bandwidth of test receiver/spectrum analyzer is 1MHz and the video bandwidth is 10Hz for Average detection (AV) at frequency above 1GHz.
4. All modes of operation were investigated and the worst-case emissions are reported.

### 4.1.4 DEVIATION FROM TEST STANDARD

No deviation

#### 4.1.5 TEST SETUP

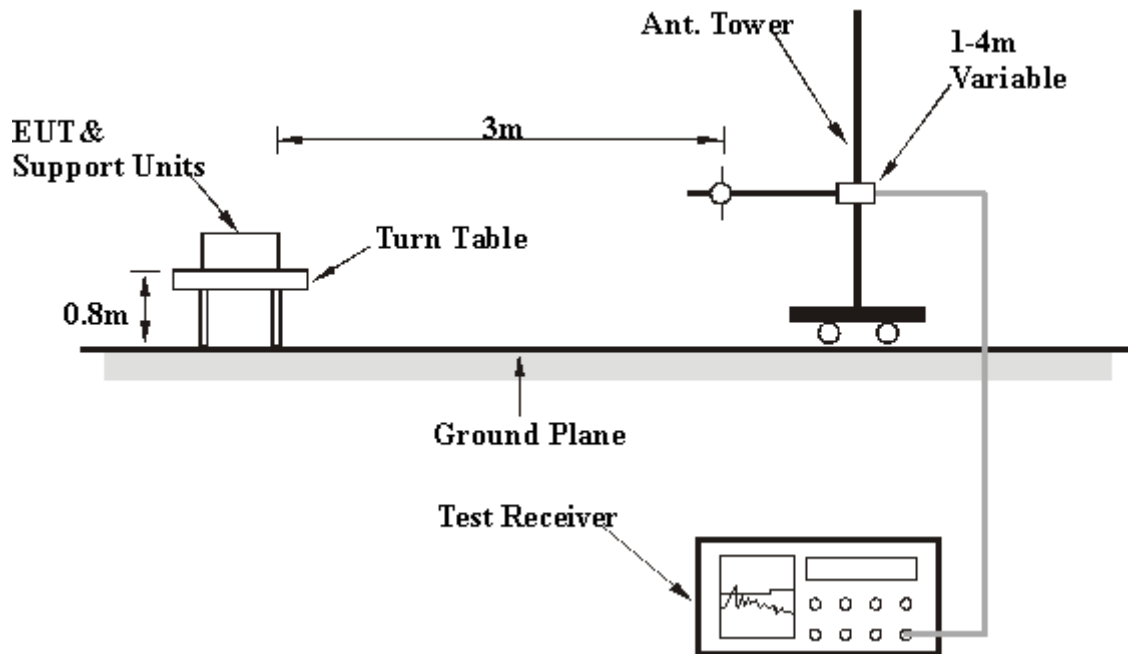

For the actual test configuration, please refer to the attached file (Test Setup Photo).

#### 4.1.6 EUT OPERATING CONDITIONS

- a. Turn on the power of all equipment.
- b. The Tablet PC (EUT) ran a test program (provided by manufacture) to enable it under transmitting condition at specific channel continuously.
- c. The Tablet PC (EUT) sent messages to LCD panel and displayed on its screen.
- d. Repeated c ~ d.



A D T

## 4.1.7 TEST RESULTS

802.11b

EUT TEST CONDITION		MEASUREMENT DETAIL	
CHANNEL	Channel 1	FREQUENCY RANGE	1 ~ 25GHz
INPUT POWER	120Vac, 60Hz	DETECTOR FUNCTION	Peak (PK) Average (AV)
ENVIRONMENTAL CONDITIONS	23deg. C, 82% RH 1005hPa	TESTED BY	Nick Chen
TEST MODE	A		

ANTENNA POLARITY & TEST DISTANCE: HORIZONTAL AT 3 M								
NO.	FREQ. (MHz)	EMISSION LEVEL (dBuV/m)	LIMIT (dBuV/m)	MARGIN (dB)	ANTENNA HEIGHT (m)	TABLE ANGLE (Degree)	RAW VALUE (dBuV)	CORRECTION FACTOR (dB/m)
1	2390.00	57.8 PK	74.0	-16.2	1.00 H	68	26.28	31.55
2	2390.00	45.8 AV	54.0	-8.2	1.00 H	68	14.24	31.55
3	*2412.00	102.4 PK			1.00 H	68	70.75	31.64
4	*2412.00	98.2 AV			1.00 H	68	66.51	31.64
5	#7236.00	56.1 PK	82.4	-26.3	1.29 H	4	12.18	43.89
6	#7236.00	45.9 AV	78.2	-32.3	1.29 H	4	1.98	43.89
7	#9648.00	60.6 PK	82.4	-21.8	1.40 H	344	13.04	47.53
8	#9648.00	52.6 AV	78.2	-25.6	1.40 H	344	5.05	47.53
ANTENNA POLARITY & TEST DISTANCE: VERTICAL AT 3 M								
NO.	FREQ. (MHz)	EMISSION LEVEL (dBuV/m)	LIMIT (dBuV/m)	MARGIN (dB)	ANTENNA HEIGHT (m)	TABLE ANGLE (Degree)	RAW VALUE (dBuV)	CORRECTION FACTOR (dB/m)
1	2390.00	59.6 PK	74.0	-14.4	1.00 V	93	28.08	31.55
2	2390.00	46.2 AV	54.0	-7.8	1.00 V	93	14.62	31.55
3	*2412.00	106.7 PK			1.00 V	93	75.07	31.64
4	*2412.00	102.2 AV			1.00 V	93	70.52	31.64
5	#7236.00	53.5 PK	86.7	-33.2	1.27 V	329	9.65	43.89
6	#7236.00	40.8 AV	82.2	-41.4	1.27 V	329	-3.11	43.89
7	#9648.00	63.6 PK	86.7	-23.1	1.33 V	346	16.11	47.53
8	#9648.00	59.5 AV	82.2	-22.7	1.33 V	346	11.95	47.53

- REMARKS:**
1. Emission level (dBuV/m) = Raw Value (dBuV) + Correction Factor (dB/m).
  2. Correction Factor (dB/m) = Antenna Factor (dB/m) + Cable Factor (dB).
  3. The other emission levels were very low against the limit.
  4. Margin value = Emission level – Limit value.
  5. “ \* “: Fundamental frequency.
  6. “#”: The radiated frequency is out the restricted band.



A D T

EUT TEST CONDITION		MEASUREMENT DETAIL	
CHANNEL	Channel 6	FREQUENCY RANGE	1 ~ 25GHz
INPUT POWER	120Vac, 60Hz	DETECTOR FUNCTION	Peak (PK) Average (AV)
ENVIRONMENTAL CONDITIONS	23deg. C, 82% RH 1005hPa	TESTED BY	Nick Chen
TEST MODE	A		

ANTENNA POLARITY & TEST DISTANCE: HORIZONTAL AT 3 M								
NO.	FREQ. (MHz)	EMISSION LEVEL (dBuV/m)	LIMIT (dBuV/m)	MARGIN (dB)	ANTENNA HEIGHT (m)	TABLE ANGLE (Degree)	RAW VALUE (dBuV)	CORRECTION FACTOR (dB/m)
1	*2437.00	103.6 PK			1.00 H	69	71.84	31.73
2	*2437.00	99.0 AV			1.00 H	69	67.31	31.73
3	7311.00	54.6 PK	74.0	-19.4	1.43 H	2	10.43	44.17
4	7311.00	43.5 AV	54.0	-10.5	1.43 H	2	-0.70	44.17
5	#9748.00	60.4 PK	83.6	-23.2	1.30 H	335	12.63	47.73
6	#9748.00	53.9 AV	79.0	-25.1	1.30 H	335	6.16	47.73
ANTENNA POLARITY & TEST DISTANCE: VERTICAL AT 3 M								
NO.	FREQ. (MHz)	EMISSION LEVEL (dBuV/m)	LIMIT (dBuV/m)	MARGIN (dB)	ANTENNA HEIGHT (m)	TABLE ANGLE (Degree)	RAW VALUE (dBuV)	CORRECTION FACTOR (dB/m)
1	*2437.00	106.0 PK			1.33 V	0	74.30	31.73
2	*2437.00	102.0 AV			1.33 V	0	70.27	31.73
3	7311.00	54.0 PK	74.0	-20.0	1.33 V	322	9.85	44.17
4	7311.00	40.8 AV	54.0	-13.2	1.33 V	322	-3.35	44.17
5	#9748.00	62.2 PK	86.0	-23.8	1.23 V	348	14.46	47.73
6	#9748.00	57.1 AV	82.0	-24.9	1.23 V	348	9.38	47.73

- REMARKS:**
1. Emission level (dBuV/m) = Raw Value (dBuV) + Correction Factor (dB/m).
  2. Correction Factor (dB/m) = Antenna Factor (dB/m) + Cable Factor (dB).
  3. The other emission levels were very low against the limit.
  4. Margin value = Emission level – Limit value.
  5. “ \* “: Fundamental frequency.
  6. “#”:The radiated frequency is out the restricted band.



A D T

EUT TEST CONDITION		MEASUREMENT DETAIL	
CHANNEL	Channel 11	FREQUENCY RANGE	1 ~ 25GHz
INPUT POWER	120Vac, 60Hz	DETECTOR FUNCTION	Peak (PK) Average (AV)
ENVIRONMENTAL CONDITIONS	23deg. C, 82% RH 1005hPa	TESTED BY	Nick Chen
TEST MODE	A		

ANTENNA POLARITY & TEST DISTANCE: HORIZONTAL AT 3 M								
NO.	FREQ. (MHz)	EMISSION LEVEL (dBuV/m)	LIMIT (dBuV/m)	MARGIN (dB)	ANTENNA HEIGHT (m)	TABLE ANGLE (Degree)	RAW VALUE (dBuV)	CORRECTION FACTOR (dB/m)
1	*2462.00	103.7 PK			1.00 H	69	71.82	31.83
2	*2462.00	99.0 AV			1.00 H	69	67.21	31.83
3	2483.50	61.0 PK	74.0	-13.0	1.00 H	69	29.07	31.91
4	2483.50	47.3 AV	54.0	-6.7	1.00 H	69	15.43	31.91
5	7386.00	55.5 PK	74.0	-18.5	1.22 H	6	11.29	44.25
6	7386.00	42.0 AV	54.0	-12.0	1.22 H	6	-2.21	44.25
7	#9848.00	60.4 PK	83.7	-23.3	1.37 H	335	12.49	47.90
8	#9848.00	54.4 AV	79.0	-24.6	1.37 H	335	6.45	47.90
ANTENNA POLARITY & TEST DISTANCE: VERTICAL AT 3 M								
NO.	FREQ. (MHz)	EMISSION LEVEL (dBuV/m)	LIMIT (dBuV/m)	MARGIN (dB)	ANTENNA HEIGHT (m)	TABLE ANGLE (Degree)	RAW VALUE (dBuV)	CORRECTION FACTOR (dB/m)
1	*2462.00	105.2 PK			1.00 V	93	73.38	31.83
2	*2462.00	100.8 AV			1.00 V	93	68.94	31.83
3	2483.50	62.4 PK	74.0	-11.6	1.00 V	93	30.50	31.91
4	2483.50	48.7 AV	54.0	-5.3	1.00 V	93	16.79	31.91
5	7386.00	53.3 PK	74.0	-20.7	1.37 V	343	9.01	44.25
6	7386.00	39.4 AV	54.0	-14.6	1.37 V	343	-4.89	44.25
7	#9848.00	62.6 PK	85.2	-22.6	1.47 V	48	14.72	47.90
8	#9848.00	58.4 AV	80.8	-22.4	1.47 V	48	10.45	47.90

- REMARKS:**
1. Emission level (dBuV/m) = Raw Value (dBuV) + Correction Factor (dB/m).
  2. Correction Factor (dB/m) = Antenna Factor (dB/m) + Cable Factor (dB).
  3. The other emission levels were very low against the limit.
  4. Margin value = Emission level – Limit value.
  5. “ \* “: Fundamental frequency.
  6. “#”:The radiated frequency is out the restricted band.



A D T

802.11g

EUT TEST CONDITION		MEASUREMENT DETAIL	
CHANNEL	Channel 1	FREQUENCY RANGE	1 ~ 25GHz
INPUT POWER	120Vac, 60Hz	DETECTOR FUNCTION	Peak (PK) Average (AV)
ENVIRONMENTAL CONDITIONS	23deg. C, 82% RH 1005hPa	TESTED BY	Nick Chen
TEST MODE	A		

ANTENNA POLARITY & TEST DISTANCE: HORIZONTAL AT 3 M								
NO.	FREQ. (MHz)	EMISSION LEVEL (dBuV/m)	LIMIT (dBuV/m)	MARGIN (dB)	ANTENNA HEIGHT (m)	TABLE ANGLE (Degree)	RAW VALUE (dBuV)	CORRECTION FACTOR (dB/m)
1	2390.00	68.8 PK	74.0	-5.2	1.00 H	68	37.25	31.55
2	2390.00	49.3 AV	54.0	-4.7	1.00 H	68	17.70	31.55
3	*2412.00	103.7 PK			1.00 H	68	72.01	31.64
4	*2412.00	92.4 AV			1.00 H	68	60.74	31.64
5	4824.00	45.9 PK	74.0	-28.1	1.06 H	68	8.19	37.73
6	4824.00	32.9 AV	54.0	-21.1	1.06 H	68	-4.87	37.73
ANTENNA POLARITY & TEST DISTANCE: VERTICAL AT 3 M								
NO.	FREQ. (MHz)	EMISSION LEVEL (dBuV/m)	LIMIT (dBuV/m)	MARGIN (dB)	ANTENNA HEIGHT (m)	TABLE ANGLE (Degree)	RAW VALUE (dBuV)	CORRECTION FACTOR (dB/m)
1	2390.00	69.6 PK	74.0	-4.4	1.00 V	92	38.02	31.55
2	2390.00	49.9 AV	54.0	-4.1	1.00 V	92	18.34	31.55
3	*2412.00	107.6 PK			1.00 V	92	75.92	31.64
4	*2412.00	95.9 AV			1.00 V	92	64.28	31.64
5	4824.00	47.1 PK	74.0	-26.9	1.00 V	281	9.39	37.73
6	4824.00	32.8 AV	54.0	-21.2	1.00 V	281	-4.89	37.73

- REMARKS:**
1. Emission level (dBuV/m) = Raw Value (dBuV) + Correction Factor (dB/m).
  2. Correction Factor (dB/m) = Antenna Factor (dB/m) + Cable Factor (dB).
  3. The other emission levels were very low against the limit.
  4. Margin value = Emission level – Limit value.
  5. “ \* “: Fundamental frequency.





A D T

EUT TEST CONDITION		MEASUREMENT DETAIL	
CHANNEL	Channel 6	FREQUENCY RANGE	1 ~ 25GHz
INPUT POWER	120Vac, 60Hz	DETECTOR FUNCTION	Peak (PK) Average (AV)
ENVIRONMENTAL CONDITIONS	23deg. C, 82% RH 1005hPa	TESTED BY	Nick Chen
TEST MODE	A		

ANTENNA POLARITY & TEST DISTANCE: HORIZONTAL AT 3 M								
NO.	FREQ. (MHz)	EMISSION LEVEL (dBuV/m)	LIMIT (dBuV/m)	MARGIN (dB)	ANTENNA HEIGHT (m)	TABLE ANGLE (Degree)	RAW VALUE (dBuV)	CORRECTION FACTOR (dB/m)
1	*2437.00	103.4 PK			1.15 H	58	71.68	31.73
2	*2437.00	92.1 AV			1.15 H	58	60.34	31.73
3	4874.00	47.7 PK	74.0	-26.3	1.26 H	330	9.79	37.91
4	4874.00	34.0 AV	54.0	-20.0	1.26 H	330	-3.92	37.91
ANTENNA POLARITY & TEST DISTANCE: VERTICAL AT 3 M								
NO.	FREQ. (MHz)	EMISSION LEVEL (dBuV/m)	LIMIT (dBuV/m)	MARGIN (dB)	ANTENNA HEIGHT (m)	TABLE ANGLE (Degree)	RAW VALUE (dBuV)	CORRECTION FACTOR (dB/m)
1	*2437.00	107.1 PK			1.05 V	0	75.37	31.73
2	*2437.00	95.6 AV			1.05 V	0	63.82	31.73
3	4874.00	48.3 PK	74.0	-25.7	1.06 V	94	10.43	37.91
4	4874.00	34.1 AV	54.0	-19.9	1.06 V	94	-3.80	37.91

- REMARKS:**
1. Emission level (dBuV/m) = Raw Value (dBuV) + Correction Factor (dB/m).
  2. Correction Factor (dB/m) = Antenna Factor (dB/m) + Cable Factor (dB).
  3. The other emission levels were very low against the limit.
  4. Margin value = Emission level – Limit value.
  5. “ \* ”: Fundamental frequency.



A D T

EUT TEST CONDITION		MEASUREMENT DETAIL	
CHANNEL	Channel 11	FREQUENCY RANGE	1 ~ 25GHz
INPUT POWER	120Vac, 60Hz	DETECTOR FUNCTION	Peak (PK) Average (AV)
ENVIRONMENTAL CONDITIONS	23deg. C, 82% RH 1005hPa	TESTED BY	Nick Chen
TEST MODE	A		

ANTENNA POLARITY & TEST DISTANCE: HORIZONTAL AT 3 M								
NO.	FREQ. (MHz)	EMISSION LEVEL (dBuV/m)	LIMIT (dBuV/m)	MARGIN (dB)	ANTENNA HEIGHT (m)	TABLE ANGLE (Degree)	RAW VALUE (dBuV)	CORRECTION FACTOR (dB/m)
1	*2462.00	104.0 PK			1.16 H	56	72.13	31.83
2	*2462.00	92.5 AV			1.16 H	56	60.67	31.83
3	2483.50	67.2 PK	74.0	-6.8	1.16 H	56	35.24	31.91
4	2483.50	48.7 AV	54.0	-5.3	1.16 H	56	16.79	31.91
5	4924.00	46.8 PK	74.0	-27.2	1.11 H	49	8.78	38.04
6	4924.00	33.1 AV	54.0	-20.9	1.11 H	49	-4.94	38.04
ANTENNA POLARITY & TEST DISTANCE: VERTICAL AT 3 M								
NO.	FREQ. (MHz)	EMISSION LEVEL (dBuV/m)	LIMIT (dBuV/m)	MARGIN (dB)	ANTENNA HEIGHT (m)	TABLE ANGLE (Degree)	RAW VALUE (dBuV)	CORRECTION FACTOR (dB/m)
1	*2462.00	108.1 PK			1.00 V	94	76.27	31.83
2	*2462.00	96.7 AV			1.00 V	94	64.85	31.83
3	2483.50	71.0 PK	74.0	-3.0	1.00 V	94	39.04	31.91
4	2483.50	50.7 AV	54.0	-3.3	1.00 V	94	18.79	31.91
5	4924.00	47.8 PK	74.0	-26.2	1.14 V	90	9.78	38.04
6	4924.00	33.8 AV	54.0	-20.2	1.14 V	90	-4.20	38.04

- REMARKS:**
1. Emission level (dBuV/m) = Raw Value (dBuV) + Correction Factor (dB/m).
  2. Correction Factor (dB/m) = Antenna Factor (dB/m) + Cable Factor (dB).
  3. The other emission levels were very low against the limit.
  4. Margin value = Emission level – Limit value.
  5. “ \* “: Fundamental frequency.



A D T

**DRAFT 802.11n (20MHz)**

EUT TEST CONDITION		MEASUREMENT DETAIL	
CHANNEL	Channel 1	FREQUENCY RANGE	1 ~ 25GHz
INPUT POWER	120Vac, 60Hz	DETECTOR FUNCTION	Peak (PK) Average (AV)
ENVIRONMENTAL CONDITIONS	23deg. C, 82% RH 1005hPa	TESTED BY	Nick Chen
TEST MODE	A		

ANTENNA POLARITY & TEST DISTANCE: HORIZONTAL AT 3 M								
NO.	FREQ. (MHz)	EMISSION LEVEL (dBuV/m)	LIMIT (dBuV/m)	MARGIN (dB)	ANTENNA HEIGHT (m)	TABLE ANGLE (Degree)	RAW VALUE (dBuV)	CORRECTION FACTOR (dB/m)
1	2390.00	66.8 PK	74.0	-7.2	1.00 H	69	35.22	31.55
2	2390.00	49.8 AV	54.0	-4.2	1.00 H	69	18.25	31.55
3	*2412.00	104.8 PK			1.00 H	69	73.16	31.64
4	*2412.00	93.1 AV			1.00 H	69	61.49	31.64
5	4824.00	47.4 PK	74.0	-26.6	1.00 H	2	9.63	37.73
6	4824.00	33.8 AV	54.0	-20.2	1.00 H	2	-3.93	37.73
ANTENNA POLARITY & TEST DISTANCE: VERTICAL AT 3 M								
NO.	FREQ. (MHz)	EMISSION LEVEL (dBuV/m)	LIMIT (dBuV/m)	MARGIN (dB)	ANTENNA HEIGHT (m)	TABLE ANGLE (Degree)	RAW VALUE (dBuV)	CORRECTION FACTOR (dB/m)
1	2390.00	67.8 PK	74.0	-6.2	1.00 V	94	36.25	31.55
2	2390.00	49.9 AV	54.0	-4.1	1.00 V	94	18.37	31.55
3	*2412.00	107.0 PK			1.00 V	94	75.37	31.64
4	*2412.00	95.5 AV			1.00 V	94	63.84	31.64
5	4824.00	47.4 PK	74.0	-26.7	1.00 V	14	9.62	37.73
6	4824.00	33.7 AV	54.0	-20.4	1.00 V	14	-4.08	37.73

- REMARKS:**
1. Emission level (dBuV/m) = Raw Value (dBuV) + Correction Factor (dB/m).
  2. Correction Factor (dB/m) = Antenna Factor (dB/m) + Cable Factor (dB).
  3. The other emission levels were very low against the limit.
  4. Margin value = Emission level – Limit value.
  5. “ \* “: Fundamental frequency.



A D T

EUT TEST CONDITION		MEASUREMENT DETAIL	
CHANNEL	Channel 6	FREQUENCY RANGE	1 ~ 25GHz
INPUT POWER	120Vac, 60Hz	DETECTOR FUNCTION	Peak (PK) Average (AV)
ENVIRONMENTAL CONDITIONS	23deg. C, 82% RH 1005hPa	TESTED BY	Nick Chen
TEST MODE	A		

ANTENNA POLARITY & TEST DISTANCE: HORIZONTAL AT 3 M								
NO.	FREQ. (MHz)	EMISSION LEVEL (dBuV/m)	LIMIT (dBuV/m)	MARGIN (dB)	ANTENNA HEIGHT (m)	TABLE ANGLE (Degree)	RAW VALUE (dBuV)	CORRECTION FACTOR (dB/m)
1	*2437.00	105.7 PK			1.00 H	70	74.01	31.73
2	*2437.00	94.5 AV			1.00 H	70	62.77	31.73
3	4874.00	47.9 PK	74.0	-26.1	1.00 H	0	10.01	37.91
4	4874.00	33.4 AV	54.0	-20.6	1.00 H	0	-4.47	37.91
ANTENNA POLARITY & TEST DISTANCE: VERTICAL AT 3 M								
NO.	FREQ. (MHz)	EMISSION LEVEL (dBuV/m)	LIMIT (dBuV/m)	MARGIN (dB)	ANTENNA HEIGHT (m)	TABLE ANGLE (Degree)	RAW VALUE (dBuV)	CORRECTION FACTOR (dB/m)
1	*2437.00	108.0 PK			1.00 V	95	76.31	31.73
2	*2437.00	96.4 AV			1.00 V	95	64.71	31.73
3	4874.00	47.3 PK	74.0	-26.7	1.00 V	256	9.37	37.91
4	4874.00	33.7 AV	54.0	-20.3	1.00 V	256	-4.21	37.91

- REMARKS:**
1. Emission level (dBuV/m) = Raw Value (dBuV) + Correction Factor (dB/m).
  2. Correction Factor (dB/m) = Antenna Factor (dB/m) + Cable Factor (dB).
  3. The other emission levels were very low against the limit.
  4. Margin value = Emission level – Limit value.
  5. “ \* ”: Fundamental frequency.



A D T

EUT TEST CONDITION		MEASUREMENT DETAIL	
CHANNEL	Channel 11	FREQUENCY RANGE	1 ~ 25GHz
INPUT POWER	120Vac, 60Hz	DETECTOR FUNCTION	Peak (PK) Average (AV)
ENVIRONMENTAL CONDITIONS	23deg. C, 82% RH 1005hPa	TESTED BY	Nick Chen
TEST MODE	A		

ANTENNA POLARITY & TEST DISTANCE: HORIZONTAL AT 3 M								
NO.	FREQ. (MHz)	EMISSION LEVEL (dBuV/m)	LIMIT (dBuV/m)	MARGIN (dB)	ANTENNA HEIGHT (m)	TABLE ANGLE (Degree)	RAW VALUE (dBuV)	CORRECTION FACTOR (dB/m)
1	*2462.00	106.1 PK			1.00 H	69	74.30	31.83
2	*2462.00	94.6 AV			1.00 H	69	62.74	31.83
3	2483.50	71.1 PK	74.0	-2.9	1.00 H	69	39.15	31.91
4	2483.50	50.2 AV	54.0	-3.8	1.00 H	69	18.31	31.91
5	4924.00	46.5 PK	74.0	-27.5	1.00 H	5	8.50	38.04
6	4924.00	32.7 AV	54.0	-21.3	1.00 H	5	-5.34	38.04
ANTENNA POLARITY & TEST DISTANCE: VERTICAL AT 3 M								
NO.	FREQ. (MHz)	EMISSION LEVEL (dBuV/m)	LIMIT (dBuV/m)	MARGIN (dB)	ANTENNA HEIGHT (m)	TABLE ANGLE (Degree)	RAW VALUE (dBuV)	CORRECTION FACTOR (dB/m)
1	*2462.00	108.1 PK			1.00 V	93	76.26	31.83
2	*2462.00	96.4 AV			1.00 V	93	64.56	31.83
3	2483.50	73.1 PK	74.0	-0.9	1.00 V	93	41.22	31.91
4	2483.50	51.1 AV	54.0	-2.9	1.00 V	93	19.23	31.91
5	4924.00	47.2 PK	74.0	-26.8	1.00 V	104	9.11	38.04
6	4924.00	33.1 AV	54.0	-20.9	1.00 V	104	-4.91	38.04

- REMARKS:**
1. Emission level (dBuV/m) = Raw Value (dBuV) + Correction Factor (dB/m).
  2. Correction Factor (dB/m) = Antenna Factor (dB/m) + Cable Factor (dB).
  3. The other emission levels were very low against the limit.
  4. Margin value = Emission level – Limit value.
  5. “ \* “: Fundamental frequency.



A D T

**DRAFT 802.11n (40MHz)**

EUT TEST CONDITION		MEASUREMENT DETAIL	
CHANNEL	Channel 1	FREQUENCY RANGE	1 ~ 25GHz
INPUT POWER	120Vac, 60Hz	DETECTOR FUNCTION	Peak (PK) Average (AV)
ENVIRONMENTAL CONDITIONS	23deg. C, 82% RH 1005hPa	TESTED BY	Nick Chen
TEST MODE	A		

ANTENNA POLARITY & TEST DISTANCE: HORIZONTAL AT 3 M								
NO.	FREQ. (MHz)	EMISSION LEVEL (dBuV/m)	LIMIT (dBuV/m)	MARGIN (dB)	ANTENNA HEIGHT (m)	TABLE ANGLE (Degree)	RAW VALUE (dBuV)	CORRECTION FACTOR (dB/m)
1	2390.00	73.5 PK	74.0	-0.5	1.00 H	67	41.96	31.55
2	2390.00	51.5 AV	54.0	-2.5	1.00 H	67	19.99	31.55
3	*2422.00	103.6 PK			1.00 H	67	71.93	31.67
4	*2422.00	86.5 AV			1.00 H	67	54.86	31.67
5	4844.00	46.3 PK	74.0	-27.7	1.02 H	34	8.45	37.80
6	4844.00	32.6 AV	54.0	-21.4	1.02 H	34	-5.16	37.80
ANTENNA POLARITY & TEST DISTANCE: VERTICAL AT 3 M								
NO.	FREQ. (MHz)	EMISSION LEVEL (dBuV/m)	LIMIT (dBuV/m)	MARGIN (dB)	ANTENNA HEIGHT (m)	TABLE ANGLE (Degree)	RAW VALUE (dBuV)	CORRECTION FACTOR (dB/m)
1	2390.00	73.9 PK	74.0	-0.1	1.00 V	93	42.35	31.55
2	2390.00	51.9 AV	54.0	-2.1	1.00 V	93	20.38	31.55
3	*2422.00	105.4 PK			1.00 V	93	73.75	31.67
4	*2422.00	86.3 AV			1.00 V	93	54.62	31.67
5	4844.00	46.0 PK	74.0	-28.0	1.00 V	106	8.21	37.80
6	4844.00	32.5 AV	54.0	-21.5	1.00 V	106	-5.31	37.80

- REMARKS:**
1. Emission level (dBuV/m) = Raw Value (dBuV) + Correction Factor (dB/m).
  2. Correction Factor (dB/m) = Antenna Factor (dB/m) + Cable Factor (dB).
  3. The other emission levels were very low against the limit.
  4. Margin value = Emission level – Limit value.
  5. “ \* “: Fundamental frequency.



A D T

EUT TEST CONDITION		MEASUREMENT DETAIL	
CHANNEL	Channel 4	FREQUENCY RANGE	1 ~ 25GHz
INPUT POWER	120Vac, 60Hz	DETECTOR FUNCTION	Peak (PK) Average (AV)
ENVIRONMENTAL CONDITIONS	23deg. C, 82% RH 1005hPa	TESTED BY	Nick Chen
TEST MODE	A		

ANTENNA POLARITY & TEST DISTANCE: HORIZONTAL AT 3 M								
NO.	FREQ. (MHz)	EMISSION LEVEL (dBuV/m)	LIMIT (dBuV/m)	MARGIN (dB)	ANTENNA HEIGHT (m)	TABLE ANGLE (Degree)	RAW VALUE (dBuV)	CORRECTION FACTOR (dB/m)
1	*2437.00	104.6 PK			1.00 H	67	72.88	31.73
2	*2437.00	87.2 AV			1.00 H	67	55.45	31.73
3	4874.00	47.4 PK	74.0	-26.6	1.00 H	13	9.46	37.91
4	4874.00	33.7 AV	54.0	-20.3	1.00 H	13	-4.18	37.91
ANTENNA POLARITY & TEST DISTANCE: VERTICAL AT 3 M								
NO.	FREQ. (MHz)	EMISSION LEVEL (dBuV/m)	LIMIT (dBuV/m)	MARGIN (dB)	ANTENNA HEIGHT (m)	TABLE ANGLE (Degree)	RAW VALUE (dBuV)	CORRECTION FACTOR (dB/m)
1	*2437.00	107.4 PK			1.00 V	93	75.65	31.73
2	*2437.00	89.0 AV			1.00 V	93	57.23	31.73
3	4874.00	47.4 PK	74.0	-26.6	1.00 V	255	9.51	37.91
4	4874.00	34.0 AV	54.0	-20.0	1.00 V	255	-3.95	37.91

- REMARKS:**
1. Emission level (dBuV/m) = Raw Value (dBuV) + Correction Factor (dB/m).
  2. Correction Factor (dB/m) = Antenna Factor (dB/m) + Cable Factor (dB).
  3. The other emission levels were very low against the limit.
  4. Margin value = Emission level – Limit value.
  5. “ \* ”: Fundamental frequency.



A D T

EUT TEST CONDITION		MEASUREMENT DETAIL	
CHANNEL	Channel 7	FREQUENCY RANGE	1 ~ 25GHz
INPUT POWER	120Vac, 60Hz	DETECTOR FUNCTION	Peak (PK) Average (AV)
ENVIRONMENTAL CONDITIONS	23deg. C, 82% RH 1005hPa	TESTED BY	Nick Chen
TEST MODE	A		

ANTENNA POLARITY & TEST DISTANCE: HORIZONTAL AT 3 M								
NO.	FREQ. (MHz)	EMISSION LEVEL (dBuV/m)	LIMIT (dBuV/m)	MARGIN (dB)	ANTENNA HEIGHT (m)	TABLE ANGLE (Degree)	RAW VALUE (dBuV)	CORRECTION FACTOR (dB/m)
1	*2452.00	101.4 PK			1.00 H	70	69.64	31.79
2	*2452.00	83.4 AV			1.00 H	70	51.63	31.79
3	2483.50	69.7 PK	74.0	-4.3	1.00 H	70	37.82	31.91
4	2483.50	50.0 AV	54.0	-4.0	1.00 H	70	18.04	31.91
5	4904.00	47.1 PK	74.0	-26.9	1.00 H	295	9.07	38.01
6	4904.00	32.7 AV	54.0	-21.3	1.00 H	295	-5.28	38.01
ANTENNA POLARITY & TEST DISTANCE: VERTICAL AT 3 M								
NO.	FREQ. (MHz)	EMISSION LEVEL (dBuV/m)	LIMIT (dBuV/m)	MARGIN (dB)	ANTENNA HEIGHT (m)	TABLE ANGLE (Degree)	RAW VALUE (dBuV)	CORRECTION FACTOR (dB/m)
1	*2452.00	102.7 PK			1.00 V	92	70.95	31.79
2	*2452.00	84.9 AV			1.00 V	92	53.13	31.79
3	2483.50	72.7 PK	74.0	-1.3	1.00 V	92	40.79	31.91
4	2483.50	50.8 AV	54.0	-3.2	1.00 V	92	18.84	31.91
5	4904.00	47.3 PK	74.0	-26.7	1.00 V	262	9.32	38.01
6	4904.00	33.6 AV	54.0	-20.4	1.00 V	262	-4.46	38.01

- REMARKS:**
1. Emission level (dBuV/m) = Raw Value (dBuV) + Correction Factor (dB/m).
  2. Correction Factor (dB/m) = Antenna Factor (dB/m) + Cable Factor (dB).
  3. The other emission levels were very low against the limit.
  4. Margin value = Emission level – Limit value.
  5. “ \* “: Fundamental frequency.





A D T

**BELOW 1GHz WORST-CASE DATA : DRAFT 802.11n (20MHz)**

EUT TEST CONDITION		MEASUREMENT DETAIL	
CHANNEL	Channel 11	FREQUENCY RANGE	Below 1000MHz
INPUT POWER	120Vac, 60Hz	DETECTOR FUNCTION	Quasi-Peak
ENVIRONMENTAL CONDITIONS	23deg. C, 82% RH 1005hPa	TESTED BY	Nick Chen
TEST MODE	A		

ANTENNA POLARITY & TEST DISTANCE: HORIZONTAL AT 3 M								
NO.	FREQ. (MHz)	EMISSION LEVEL (dBuV/m)	LIMIT (dBuV/m)	MARGIN (dB)	ANTENNA HEIGHT (m)	TABLE ANGLE (Degree)	RAW VALUE (dBuV)	CORRECTION FACTOR (dB/m)
1	57.21	31.5 QP	40.0	-8.5	1.02 H	40	18.75	12.77
2	274.93	33.9 QP	46.0	-12.1	1.17 H	10	19.70	14.20
3	323.53	32.3 QP	46.0	-13.7	1.24 H	322	16.27	16.04
4	387.68	31.3 QP	46.0	-14.7	1.02 H	49	13.57	17.77
5	599.56	30.6 QP	46.0	-15.5	1.26 H	247	7.34	23.21
6	642.32	29.6 QP	46.0	-16.4	1.02 H	292	5.70	23.91
7	700.64	30.7 QP	46.0	-15.3	1.28 H	55	5.91	24.82
8	733.69	34.0 QP	46.0	-12.0	1.02 H	253	8.55	25.47
9	902.81	30.2 QP	46.0	-15.9	1.00 H	175	2.08	28.07
ANTENNA POLARITY & TEST DISTANCE: VERTICAL AT 3 M								
NO.	FREQ. (MHz)	EMISSION LEVEL (dBuV/m)	LIMIT (dBuV/m)	MARGIN (dB)	ANTENNA HEIGHT (m)	TABLE ANGLE (Degree)	RAW VALUE (dBuV)	CORRECTION FACTOR (dB/m)
1	57.21	39.3 QP	40.0	-0.8	1.11 V	202	26.48	12.77
2	420.72	29.3 QP	46.0	-16.7	1.24 V	319	10.56	18.74
3	599.56	29.6 QP	46.0	-16.4	1.03 V	64	6.37	23.21
4	630.66	29.4 QP	46.0	-16.6	1.27 V	319	5.70	23.72
5	733.69	33.8 QP	46.0	-12.2	1.24 V	4	8.33	25.47
6	760.90	29.3 QP	46.0	-16.7	1.01 V	40	3.34	25.97
7	902.81	29.9 QP	46.0	-16.1	1.00 V	175	1.87	28.07

- REMARKS:**
1. Emission level (dBuV/m) = Raw Value (dBuV) + Correction Factor (dB/m).
  2. Correction Factor (dB/m) = Antenna Factor (dB/m) + Cable Factor (dB).
  3. The other emission levels were very low against the limit.
  4. Margin value = Emission level – Limit value.



A D T

EUT TEST CONDITION		MEASUREMENT DETAIL	
CHANNEL	Channel 11	FREQUENCY RANGE	Below 1000MHz
INPUT POWER	7.4Vdc	DETECTOR FUNCTION	Quasi-Peak
ENVIRONMENTAL CONDITIONS	23deg. C, 82% RH 1005hPa	TESTED BY	Nick Chen
TEST MODE	B		

ANTENNA POLARITY & TEST DISTANCE: HORIZONTAL AT 3 M								
NO.	FREQ. (MHz)	EMISSION LEVEL (dBuV/m)	LIMIT (dBuV/m)	MARGIN (dB)	ANTENNA HEIGHT (m)	TABLE ANGLE (Degree)	RAW VALUE (dBuV)	CORRECTION FACTOR (dB/m)
1	55.27	28.6 QP	40.0	-11.4	1.22 H	169	15.91	12.73
2	189.40	28.8 QP	43.5	-14.8	1.08 H	238	16.85	11.90
3	274.93	33.5 QP	46.0	-12.5	1.36 H	4	19.28	14.20
4	323.53	34.3 QP	46.0	-11.7	1.39 H	61	18.27	16.04
5	387.68	33.2 QP	46.0	-12.8	1.07 H	10	15.44	17.77
6	733.69	34.3 QP	46.0	-11.7	1.32 H	259	8.79	25.47
7	799.78	33.9 QP	46.0	-12.2	1.10 H	133	7.24	26.61
ANTENNA POLARITY & TEST DISTANCE: VERTICAL AT 3 M								
NO.	FREQ. (MHz)	EMISSION LEVEL (dBuV/m)	LIMIT (dBuV/m)	MARGIN (dB)	ANTENNA HEIGHT (m)	TABLE ANGLE (Degree)	RAW VALUE (dBuV)	CORRECTION FACTOR (dB/m)
1	33.89	39.0 QP	40.0	-1.0	1.00 V	139	26.76	12.26
2	63.05	30.5 QP	40.0	-9.6	1.21 V	205	17.82	12.63
3	181.62	29.0 QP	43.5	-14.5	1.04 V	211	16.63	12.40
4	420.72	32.4 QP	46.0	-13.6	1.23 V	280	13.68	18.74
5	696.75	33.5 QP	46.0	-12.6	1.06 V	31	8.69	24.76
6	733.69	34.0 QP	46.0	-12.0	1.22 V	37	8.53	25.47
7	776.45	32.0 QP	46.0	-14.0	1.21 V	10	5.78	26.23
8	797.84	32.0 QP	46.0	-14.0	1.11 V	16	5.46	26.57

- REMARKS:**
1. Emission level (dBuV/m) = Raw Value (dBuV) + Correction Factor (dB/m).
  2. Correction Factor (dB/m) = Antenna Factor (dB/m) + Cable Factor (dB).
  3. The other emission levels were very low against the limit.
  4. Margin value = Emission level – Limit value.



A D T

## 4.2 CONDUCTED EMISSION MEASUREMENT

### 4.2.1 LIMITS OF CONDUCTED EMISSION MEASUREMENT

FREQUENCY OF EMISSION (MHz)	CONDUCTED LIMIT (dB $\mu$ V)	
	Quasi-peak	Average
0.15 ~ 0.5	66 to 56	56 to 46
0.5 ~ 5	56	46
5 ~ 30	60	50

- NOTE:** 1. The lower limit shall apply at the transition frequencies.  
2. The limit decreases in line with the logarithm of the frequency in the range of 0.15 to 0.50MHz.  
3. All emanations from a class A/B digital device or system, including any network of conductors and apparatus connected thereto, shall not exceed the level of field strengths specified above.

### 4.2.2 TEST INSTRUMENTS

DESCRIPTION & MANUFACTURER	MODEL NO.	SERIAL NO.	CALIBRATED DATE	CALIBRATED UNTIL
ROHDE & SCHWARZ Test Receiver	ESCS 30	838251/021	Mar. 05, 2009	Mar. 04, 2010
ROHDE & SCHWARZ Artificial Mains Network (for EUT)	ESH3-Z5	100218	Nov. 24, 2008	Nov. 23, 2009
LISN With Adapter (for EUT)	AD10	C10Ada-001	Nov. 24, 2008	Nov. 23, 2009
ROHDE & SCHWARZ Artificial Mains Network (for peripherals)	ESH3-Z5	100219	Nov. 23, 2009	Nov. 22, 2010
Software	ADT_Cond_V7.3.7	NA	NA	NA
Software	ADT_ISN_V7.3.7	NA	NA	NA
RF cable (JYEBAO)	5D-FB	Cable-C10.01	Feb. 26, 2009	Feb. 25, 2010
SUHNER Terminator (For ROHDE & SCHWARZ LISN)	65BNC-5001	E1-010773	Feb. 27, 2009	Feb. 26, 2010

- NOTE:** 1. The calibration interval of the above test instruments is 12 months and the calibrations are traceable to NML/ROC and NIST/USA.  
2. The test was performed in Shielded Room No. 10.  
3. The VCCI Site Registration No. C-1852.



A D T

### 4.2.3 TEST PROCEDURES

- a. The EUT was placed 0.4 meters from the conducting wall of the shielded room with EUT being connected to the power mains through a line impedance stabilization network (LISN). Other support units were connected to the power mains through another LISN. The two LISNs provide 50 ohm/ 50uH of coupling impedance for the measuring instrument.
- b. Both lines of the power mains connected to the EUT were checked for maximum conducted interference.
- c. The frequency range from 150kHz to 30MHz was searched. Emission levels under (Limit - 20dB) was not recorded.

**NOTE:** All modes of operation were investigated and the worst-case emissions are reported.

### 4.2.4 DEVIATION FROM TEST STANDARD

No deviation

## 4.2.5 TEST SETUP

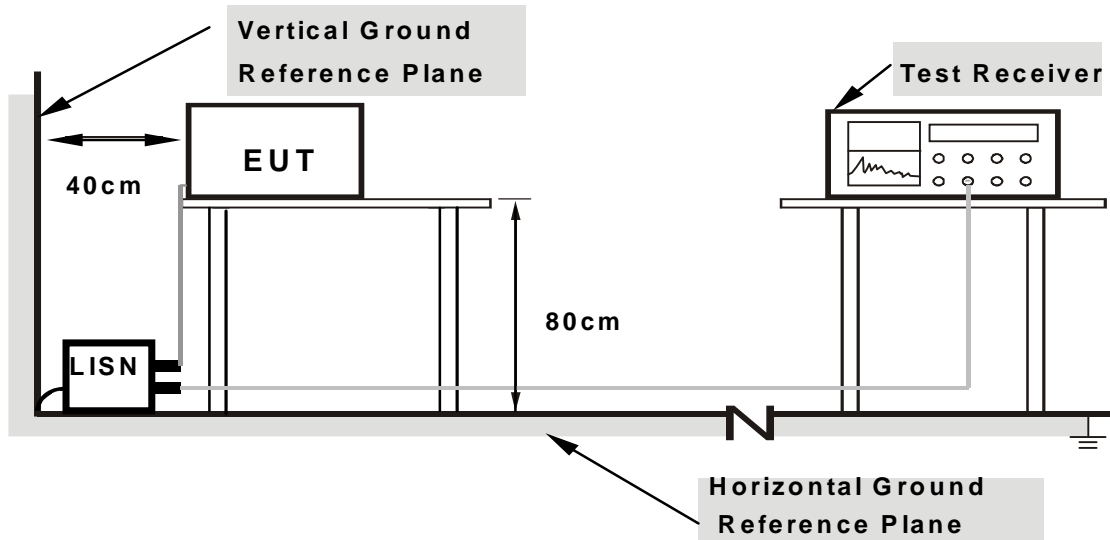

- Note:**
1. Support units were connected to second LISN.
  2. Both of LISNs (AMN) are 80 cm from EUT and at least 80 cm from other units and other metal planes

For the actual test configuration, please refer to the attached file (Test Setup Photo).

## 4.2.6 EUT OPERATING CONDITIONS

Same as 4.1.6.

### 4.2.7 TEST RESULTS

CONDUCTED WORST-CASE DATA : 802.11n (20MHz)

CHANNEL	Channel 11	PHASE	Line 1
TEST MODE	A	6dB BANDWIDTH	9kHz

No	Freq. [MHz]	Corr. Factor (dB)	Reading Value		Emission Level		Limit		Margin	
			[dB (uV)]		[dB (uV)]		[dB (uV)]		(dB)	
			Q.P.	AV.	Q.P.	AV.	Q.P.	AV.	Q.P.	AV.
1	0.189	0.13	48.44	-	48.57	-	64.07	54.07	-15.50	-
2	0.283	0.17	36.66	-	36.83	-	60.72	50.72	-23.88	-
3	0.656	0.25	39.71	-	39.96	-	56.00	46.00	-16.04	-
4	1.319	0.31	32.53	-	32.84	-	56.00	46.00	-23.16	-
5	3.854	0.51	31.95	-	32.46	-	56.00	46.00	-23.54	-
6	16.249	1.30	37.44	-	38.74	-	60.00	50.00	-21.26	-

- REMARKS:**
1. Q.P. and AV. are abbreviations of quasi-peak and average individually.
  2. "-": The Quasi-peak reading value also meets average limit and measurement with the average detector is unnecessary.
  3. The emission levels of other frequencies were very low against the limit.
  4. Margin value = Emission level - Limit value
  5. Correction factor = Insertion loss + Cable loss
  6. Emission Level = Correction Factor + Reading Value.

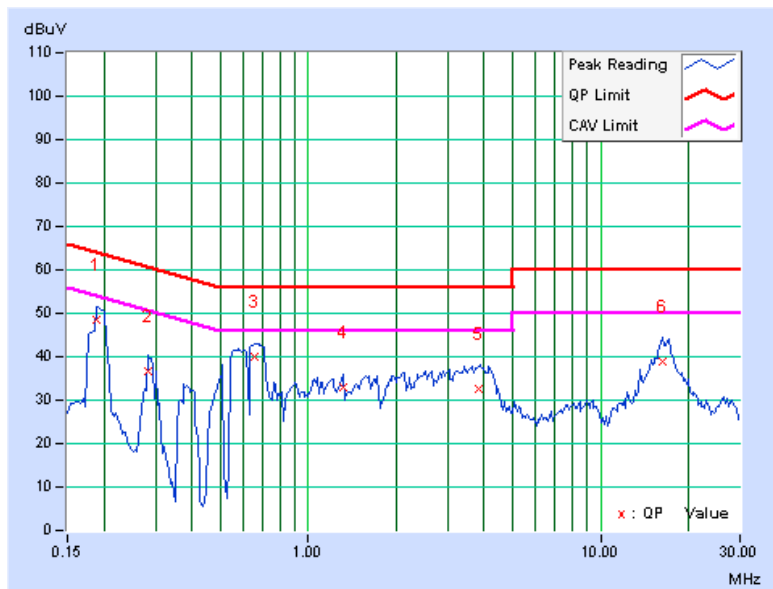



A D T

<b>CHANNEL</b>	Channel 11	<b>PHASE</b>	Line 2
<b>TEST MODE</b>	A	<b>6dB BANDWIDTH</b>	9kHz

No	Freq. [MHz]	Corr. Factor (dB)	Reading Value		Emission Level		Limit		Margin	
			[dB (uV)]		[dB (uV)]		[dB (uV)]		(dB)	
			Q.P.	AV.	Q.P.	AV.	Q.P.	AV.	Q.P.	AV.
1	0.185	0.13	46.42	-	46.55	-	64.28	54.28	-17.73	-
2	0.276	0.17	36.48	-	36.65	-	60.92	50.92	-24.28	-
<b>3</b>	<b>0.678</b>	<b>0.29</b>	<b>42.38</b>	-	<b>42.67</b>	-	<b>56.00</b>	<b>46.00</b>	<b>-13.33</b>	-
4	1.622	0.42	37.40	-	37.82	-	56.00	46.00	-18.18	-
5	2.531	0.49	34.99	-	35.48	-	56.00	46.00	-20.52	-
6	16.262	1.15	37.38	-	38.53	-	60.00	50.00	-21.47	-

- REMARKS:**
1. Q.P. and AV. are abbreviations of quasi-peak and average individually.
  2. "-": The Quasi-peak reading value also meets average limit and measurement with the average detector is unnecessary.
  3. The emission levels of other frequencies were very low against the limit.
  4. Margin value = Emission level - Limit value
  5. Correction factor = Insertion loss + Cable loss
  6. Emission Level = Correction Factor + Reading Value.

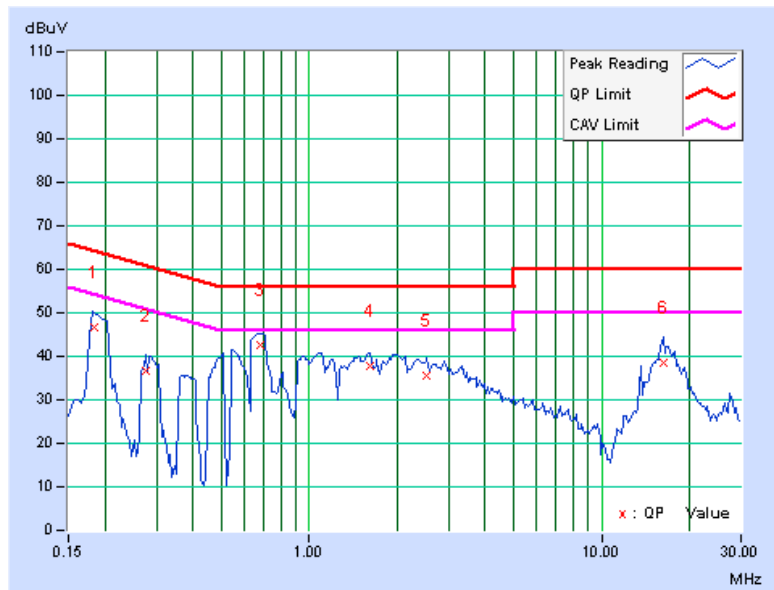



A D T

## 4.3 6dB BANDWIDTH MEASUREMENT

### 4.3.1 LIMITS OF 6dB BANDWIDTH MEASUREMENT

The minimum of 6dB Bandwidth Measurement is 0.5 MHz.

### 4.3.2 TEST INSTRUMENTS

DESCRIPTION & MANUFACTURER	MODEL NO.	SERIAL NO.	DATE OF CALIBRATION	DUE DATE OF CALIBRATION
R&S SPECTRUM ANALYZER	FSP 40	100036	Apr. 03, 2009	Apr. 02, 2010

**NOTE:** The calibration interval of the above test instruments is 12 months and the calibrations are traceable to NML/ROC and NIST/USA.

### 4.3.3 TEST PROCEDURE

The transmitter output was connected to the spectrum analyzer through an attenuator. The bandwidth of the fundamental frequency was measured by spectrum analyzer with 100kHz RBW and 300kHz VBW. The 6dB bandwidth is defined as the total spectrum the power of which is higher than peak power minus 6dB.

### 4.3.4 DEVIATION FROM TEST STANDARD

No deviation



### 4.3.5 TEST SETUP

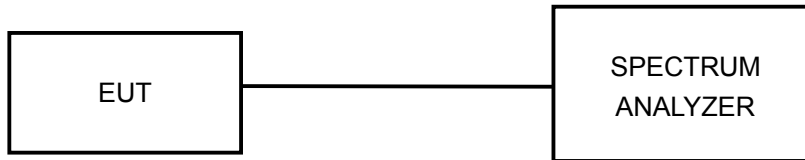

### 4.3.6 EUT OPERATING CONDITIONS

The software provided by client to enable the EUT under transmission condition continuously at lowest, middle and highest channel frequencies individually.



A D T

### 4.3.7 TEST RESULTS

#### 802.11b

CHANNEL	CHANNEL FREQUENCY (MHz)	6dB BANDWIDTH (MHz)	MINIMUM LIMIT (MHz)	PASS / FAIL
1	2412	10.22	0.5	PASS
6	2437	10.29	0.5	PASS
11	2462	10.32	0.5	PASS

#### CH 11

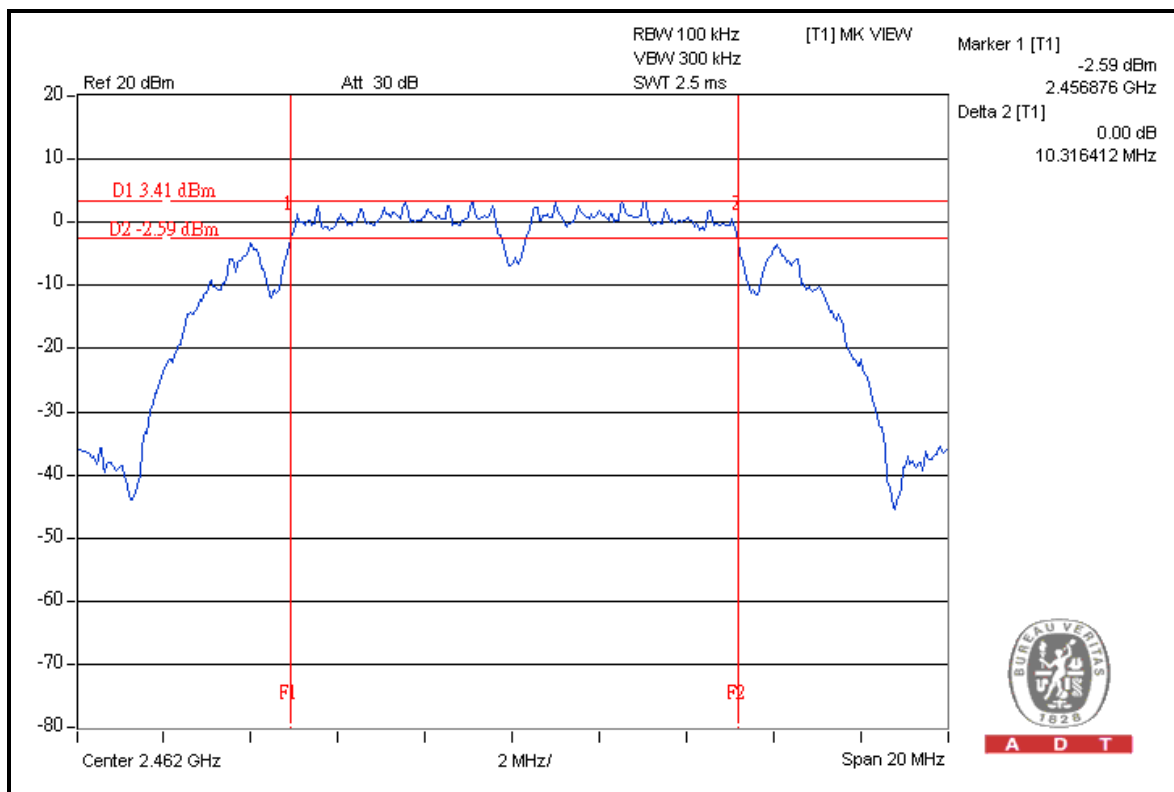

A D T



A D T

### 802.11g

CHANNEL	CHANNEL FREQUENCY (MHz)	6dB BANDWIDTH (MHz)	MINIMUM LIMIT (MHz)	PASS / FAIL
1	2412	16.41	0.5	PASS
6	2437	16.45	0.5	PASS
11	2462	16.40	0.5	PASS

### CH 6

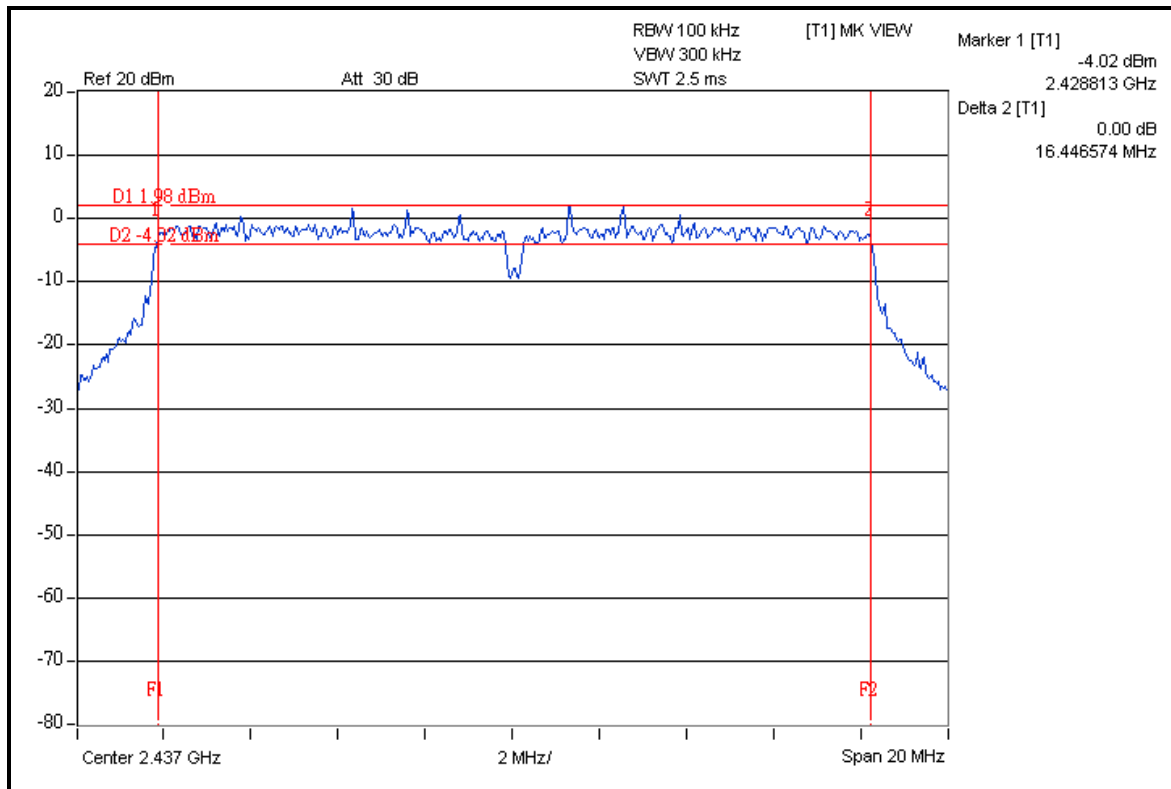



A D T

### 802.11n (20MHz)

CHANNEL	CHANNEL FREQUENCY (MHz)	6dB BANDWIDTH (MHz)	MINIMUM LIMIT (MHz)	PASS / FAIL
1	2412	17.63	0.5	PASS
6	2437	17.57	0.5	PASS
11	2462	17.61	0.5	PASS

### CH 1

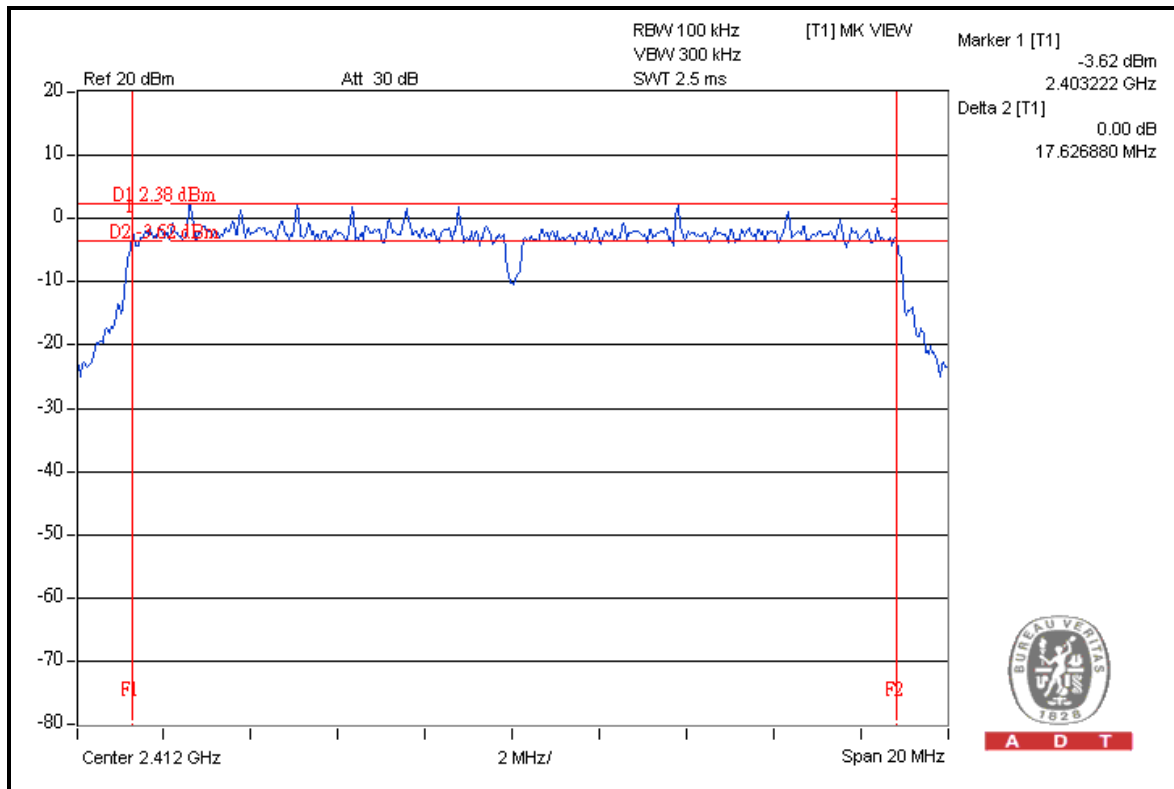



A D T

### 802.11n (40MHz)

CHANNEL	CHANNEL FREQUENCY (MHz)	6dB BANDWIDTH (MHz)	MINIMUM LIMIT (MHz)	PASS / FAIL
1	2422	35.52	0.5	PASS
4	2437	35.28	0.5	PASS
7	2452	35.49	0.5	PASS

### CH 1

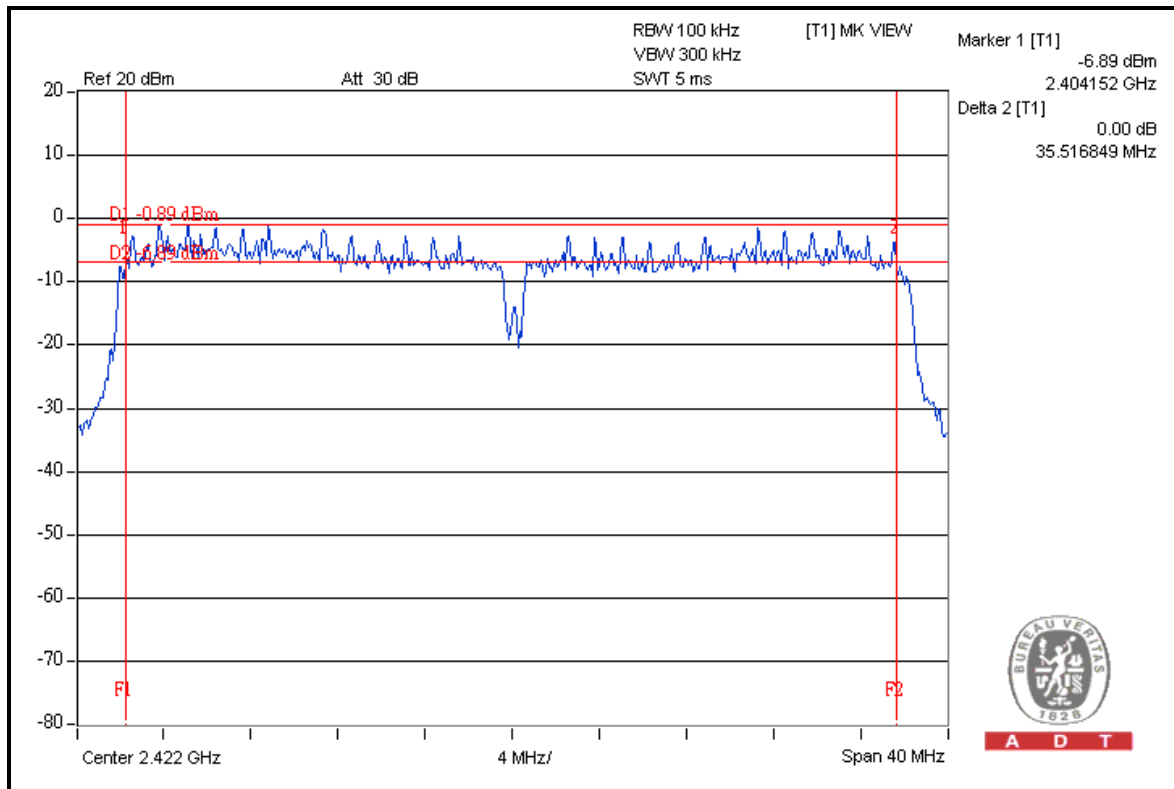



A D T

## 4.4 MAXIMUM OUTPUT POWER

### 4.4.1 LIMITS OF MAXIMUM PEAK OUTPUT POWER MEASUREMENT

The Maximum Output Power Measurement is 30dBm.

### 4.4.2 INSTRUMENTS

DESCRIPTION & MANUFACTURER	MODEL NO.	SERIAL NO.	DATE OF CALIBRATION	DUE DATE OF CALIBRATION
Peak Power meter & Anritsu	ML2495A	0842014	Apr. 25, 2009	Apr. 24, 2010
Pulse Power Sensor & Anritsu	MA2411B	0738404	Apr. 25, 2009	Apr. 24, 2010

**Note:**

1. The calibration interval of the above test instruments is 12 months and the calibrations are traceable to NML/ROC and NIST/USA.
2. Measurement Bandwidth of ML2495A is 65MHz greater than 6dB bandwidth of emission.

### 4.4.3 TEST PROCEDURES

A power sensor was used on the output port of the EUT. A power meter was used to read the response of the power sensor. Record the power level.

#### 4.4.4 DEVIATION FROM TEST STANDARD

No deviation

#### 4.4.5 TEST SETUP

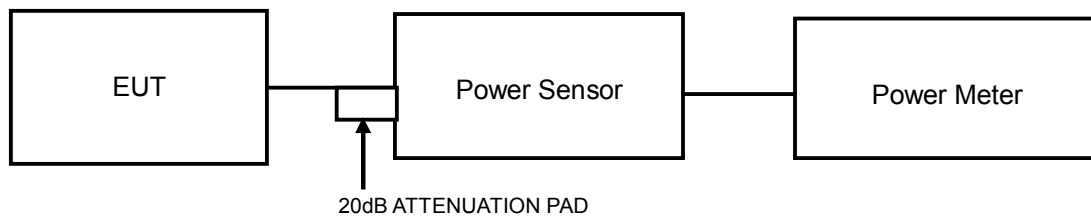

#### 4.4.6 EUT OPERATING CONDITIONS

Same as Item 4.3.6



## 4.4.7 TEST RESULTS

### 802.11b

CHANNEL	CHANNEL FREQUENCY (MHz)	PEAK OUTPUT POWER (dBm)	PEAK OUTPUT POWER (mW)	PEAK OUTPUT POWER (dBm)	PASS / FAIL
1	2412	18.5	70.8	30	PASS
6	2437	18.2	66.1	30	PASS
11	2462	18.1	64.6	30	PASS

### 802.11g

CHANNEL	CHANNEL FREQUENCY (MHz)	PEAK OUTPUT POWER (dBm)	PEAK OUTPUT POWER (mW)	PEAK OUTPUT POWER (dBm)	PASS / FAIL
1	2412	23.7	234.4	30	PASS
6	2437	23.7	234.4	30	PASS
11	2462	23.4	218.8	30	PASS

### 802.11n (20MHz)

CHANNEL	CHANNEL FREQUENCY (MHz)	PEAK OUTPUT POWER (dBm)	PEAK OUTPUT POWER (mW)	PEAK OUTPUT POWER (dBm)	PASS / FAIL
1	2412	23.8	239.9	30	PASS
6	2437	23.5	223.9	30	PASS
11	2462	23.3	213.8	30	PASS





A D T

802.11n (40MHz)

CHANNEL	CHANNEL FREQUENCY (MHz)	PEAK OUTPUT POWER (dBm)	PEAK OUTPUT POWER (mW)	PEAK OUTPUT POWER (dBm)	PASS / FAIL
1	2422	24.0	251.2	30	PASS
4	2437	24.4	275.4	30	PASS
7	2452	22.8	190.5	30	PASS



A D T

## 4.5 POWER SPECTRAL DENSITY MEASUREMENT

### 4.5.1 LIMITS OF POWER SPECTRAL DENSITY MEASUREMENT

The Maximum of Power Spectral Density Measurement is 8dBm.

### 4.5.2 TEST INSTRUMENTS

DESCRIPTION & MANUFACTURER	MODEL NO.	SERIAL NO.	DATE OF CALIBRATION	DUE DATE OF CALIBRATION
R&S SPECTRUM ANALYZER	FSP 40	100036	Apr. 03, 2009	Apr. 02, 2010

**NOTE:** The calibration interval of the above test instruments is 12 months and the calibrations are traceable to NML/ROC and NIST/USA.

### 4.5.3 TEST PROCEDURE

The transmitter output was connected to the spectrum analyzer through an attenuator, the bandwidth of the fundamental frequency was measured with the spectrum analyzer using 3kHz RBW and 30kHz VBW, set sweep time = span/3kHz. The power spectral density was measured and recorded.

The sweep time is allowed to be longer than span/3kHz for a full response of the mixer in the spectrum analyzer.



A D T

#### 4.5.4 DEVIATION FROM TEST STANDARD

No deviation

#### 4.5.5 TEST SETUP

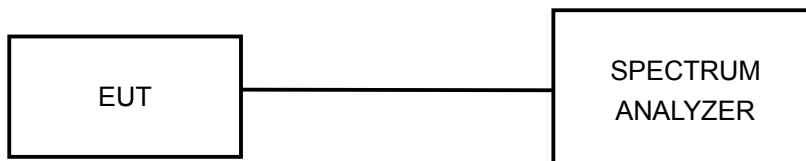

#### 4.5.6 EUT OPERATING CONDITION

Same as Item 4.3.6



A D T

## 4.5.7 TEST RESULTS

### 802.11b

CHANNEL	CHANNEL FREQUENCY (MHz)	RF POWER LEVEL IN 3kHz BW (dBm)	MAXIMUM LIMIT (dBm)	PASS / FAIL
1	2412	-9.9	8	PASS
6	2437	-10.9	8	PASS
11	2462	-11.0	8	PASS

### CH 1

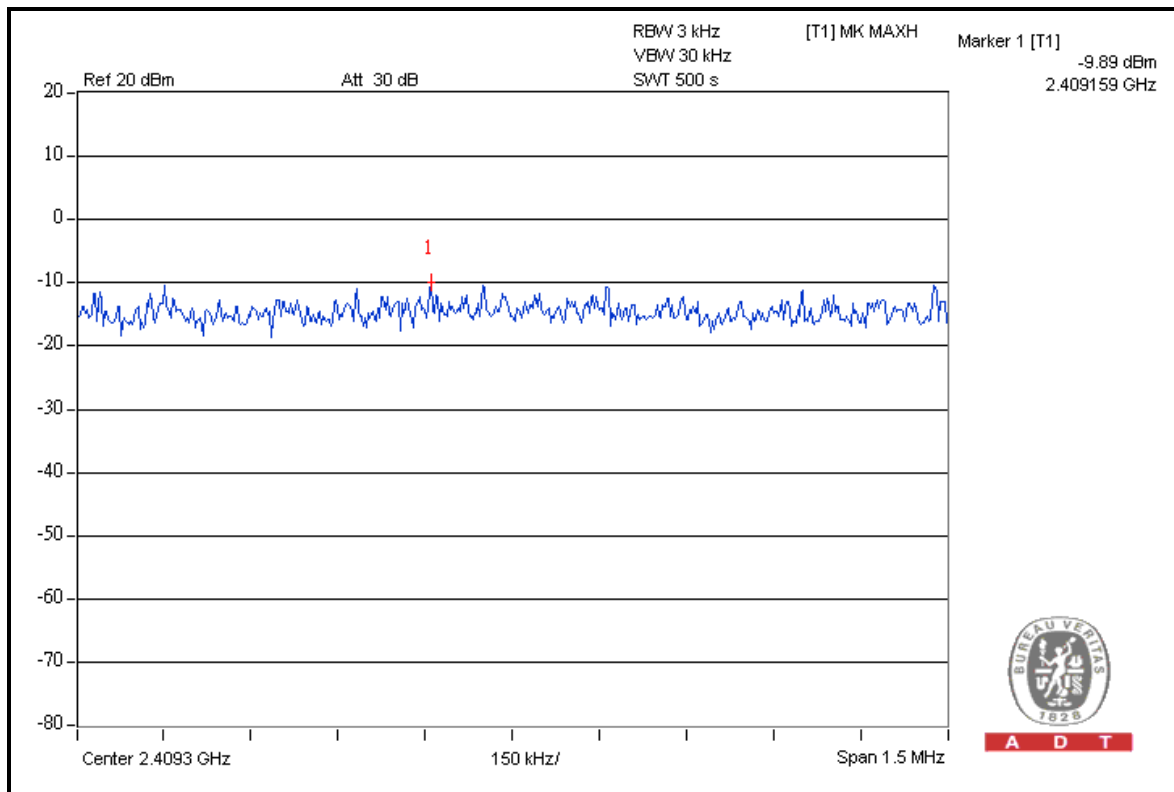



A D T

802.11g

CHANNEL	CHANNEL FREQUENCY (MHz)	RF POWER LEVEL IN 3kHz BW (dBm)	MAXIMUM LIMIT (dBm)	PASS / FAIL
1	2412	-12.8	8	PASS
6	2437	-12.6	8	PASS
11	2462	-11.9	8	PASS

CH 11

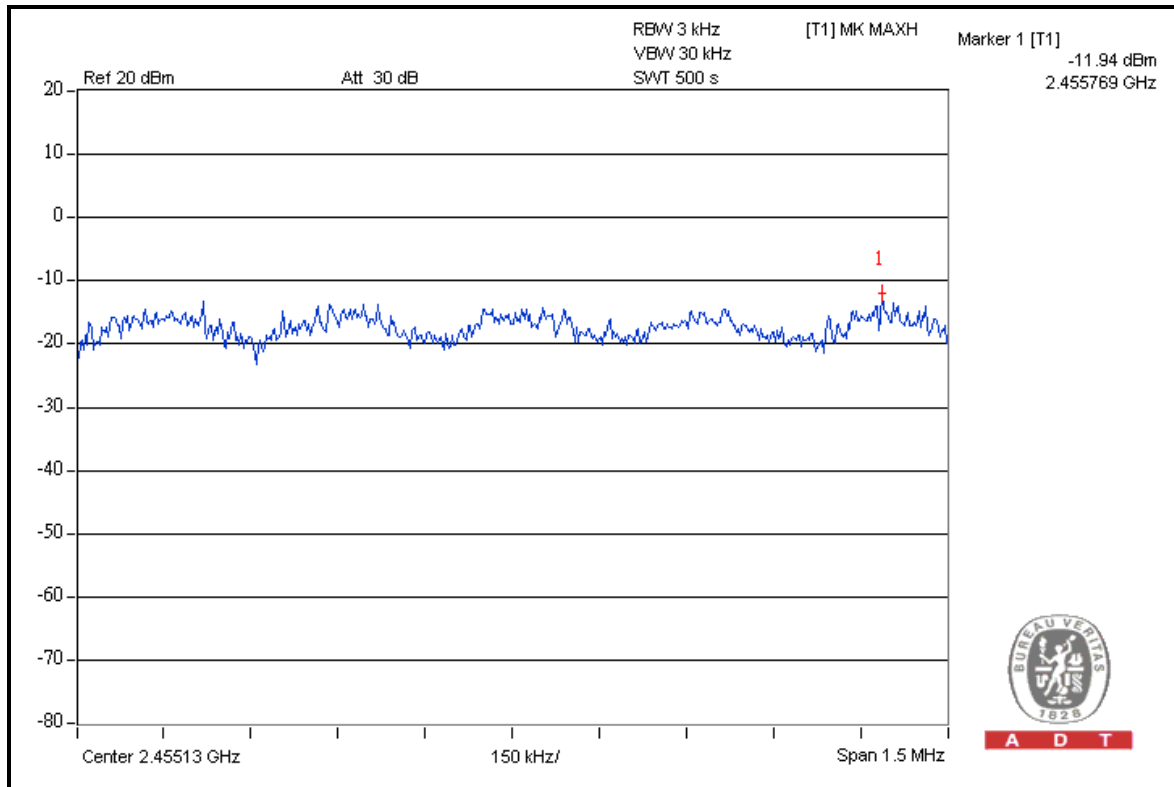

A D T





A D T

### 802.11n (40MHz)

CHANNEL	CHANNEL FREQUENCY (MHz )	RF POWER LEVEL IN 3kHz BW (dBm)	MAXIMUM LIMIT (dBm)	PASS / FAIL
1	2422	-14.2	8	PASS
4	2437	-11.3	8	PASS
7	2452	-16.5	8	PASS

### CH 4

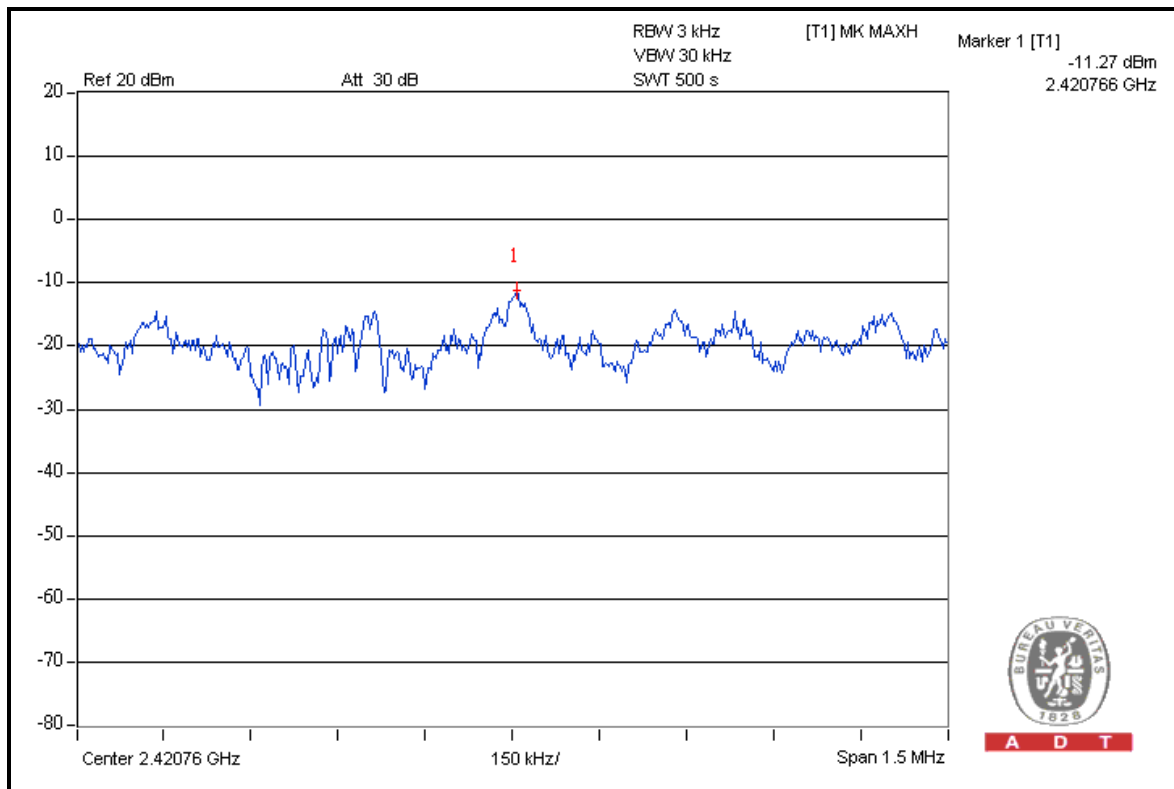



A D T

## 4.6 BAND EDGES MEASUREMENT

### 4.6.1 LIMITS OF BAND EDGES MEASUREMENT

Below -20dB of the highest emission level of operating band (in 100kHz Resolution Bandwidth).

### 4.6.2 TEST INSTRUMENTS

DESCRIPTION & MANUFACTURER	MODEL NO.	SERIAL NO.	DATE OF CALIBRATION	CALIBRATED UNTIL
<b>FOR CONDUCTED MEASUREMENT:</b>				
R&S SPECTRUM ANALYZER	FSP 40	100036	Apr. 03, 2009	Apr. 02, 2010
<b>FOR RADIATED MEASUREMENT:</b>				
HP Preamplifier	8447D	2432A03504	May 04, 2009	May 03, 2010
HP Preamplifier	8449B	3008A01924	Aug. 31, 2009	Aug. 30, 2010
HP Preamplifier	8449B	3008A01292	Aug. 10, 2009	Aug. 09, 2010
ROHDE & SCHWARZ TEST RECEIVER	ESU26	100005	Jun. 06, 2009	Jun. 05, 2010
Schwarzbeck Antenna	VULB 9168	137	Apr. 29, 2009	Apr. 28, 2010
Schwarzbeck Antenna	VHBA 9123	480	Apr. 21, 2009	Apr. 20, 2010
EMCO Horn Antenna	3115	6714	Oct. 26, 2009	Oct. 25, 2010
EMCO Horn Antenna	3115	9312-4192	Apr. 17, 2009	Apr. 16, 2010
ADT. Turn Table	TT100	0306	NA	NA
ADT. Tower	AT100	0306	NA	NA
Software	ADT_Radiated_V7.6.15.9.2	NA	NA	NA
SUHNER RF cable	SF104-26.5	CABLE-CH6-17 m-01	Aug. 20, 2009	Aug. 19, 2010
ROHDE & SCHWARZ Spectrum Analyzer	FSP 40	100036	Apr. 03, 2009	Apr. 02, 2010

**NOTE:** The calibration interval of the above test instruments is 12 months and the calibrations are traceable to NML/ROC and NIST/USA.





A D T

### 4.6.3 TEST PROCEDURE

#### FOR CONDUCTED MEASUREMENT:

The transmitter output was connected to the spectrum analyzer via a low loss cable. Set both RBW and VBW of spectrum analyzer to 100kHz and 300kHz with suitable frequency span including 100MHz bandwidth from band edge. The band edges was measured and recorded.

The spectrum plots (Peak RBW =100kHz, VBW = 300kHz; Average RBW = 1MHz, VBW = 10Hz) are attached on the following pages.

#### FOR RADIATED MEASUREMENT:

- a. The EUT was placed on the top of a rotating table 0.8 meters above the ground at a 3 meter semi-anechoic chamber. The table was rotated 360 degrees to determine the position of the highest radiation.
- b. The EUT was set 3 meters away from the interference-receiving antenna, which was mounted on the top of a variable-height antenna tower.
- c. The height of antenna is varied from one meter to four meters above the ground to determine the maximum value of the field strength. Both horizontal and vertical polarizations of the antenna are set to make the measurement.
- d. For each suspected emission, the EUT was arranged to its worst case and then the antenna was tuned to heights from 1 meter to 4 meters and the rotatable table was turned from 0 degrees to 360 degrees to find the maximum reading.
- e. Set both RBW and VBW of spectrum analyzer to 100kHz and 300kHz with suitable frequency span including 100MHz bandwidth from band edge. The band edges was measured and recorded.

The spectrum plots (Peak RBW =100kHz, VBW = 300kHz; Average RBW = 1MHz, VBW = 10Hz) are attached on the following pages.

**NOTE:** The resolution bandwidth of test receiver/spectrum analyzer is 1MHz and the video bandwidth is 10Hz for Average detection (AV) at frequency above 1GHz.

### 4.6.4 DEVIATION FROM TEST STANDARD

No deviation

### 4.6.5 EUT OPERATING CONDITION

Same as Item 4.3.6



A D T

## 4.6.6 TEST RESULTS

The spectrum plots are attached on the following pages. D1 line indicates the highest level, and D2 line indicates the 20dB offset below D1. It shows compliance with the requirement in part 15.247(d).

### 802.11b

#### RESTRICT BAND (2310 ~ 2390 MHz)

FREQUENCY (MHz)	FUNDAMENTAL EMISSION (dBuV/m)	DELTA (dB)	MAXIMUM FIELD STRENGTH IN RESTRICT BAND (dBuV/m)	LIMIT (dBuV/m)
2412.00 (PK)	106.7	51.3	55.4	74.00
2412.00 (AV)	102.2	58.8	43.4	54.00

#### RESTRICT BAND (2483.5 ~ 2500 MHz)

FREQUENCY (MHz)	FUNDAMENTAL EMISSION (dBuV/m)	DELTA (dB)	MAXIMUM FIELD STRENGTH IN RESTRICT BAND (dBuV/m)	LIMIT (dBuV/m)
2462.00 (PK)	105.2	49.1	56.1	74.00
2462.00 (AV)	100.8	56.6	44.2	54.00

#### NOTE:

1. Delta = Amplitude between the peak of the fundamental and the peak of the band edge emission. Please check following 3 pages.
2. Maximum field strength in restrict band = Fundamental emission – Delta.



A D T

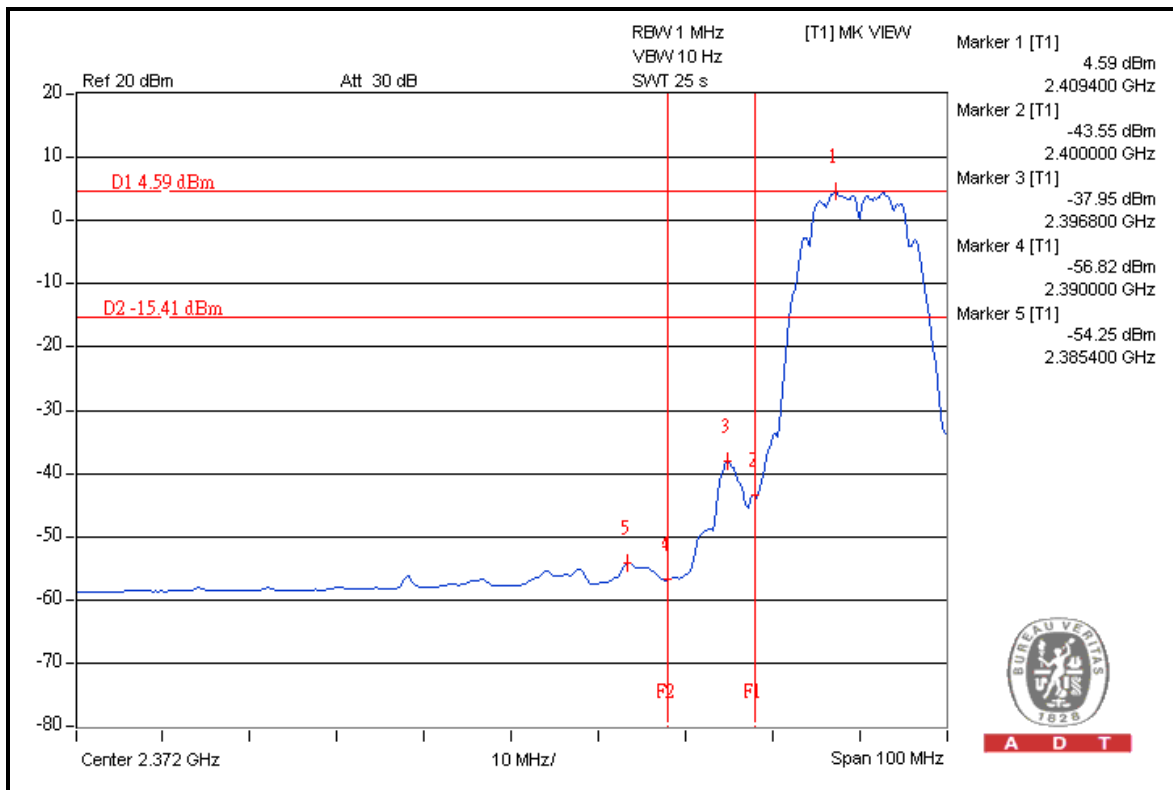
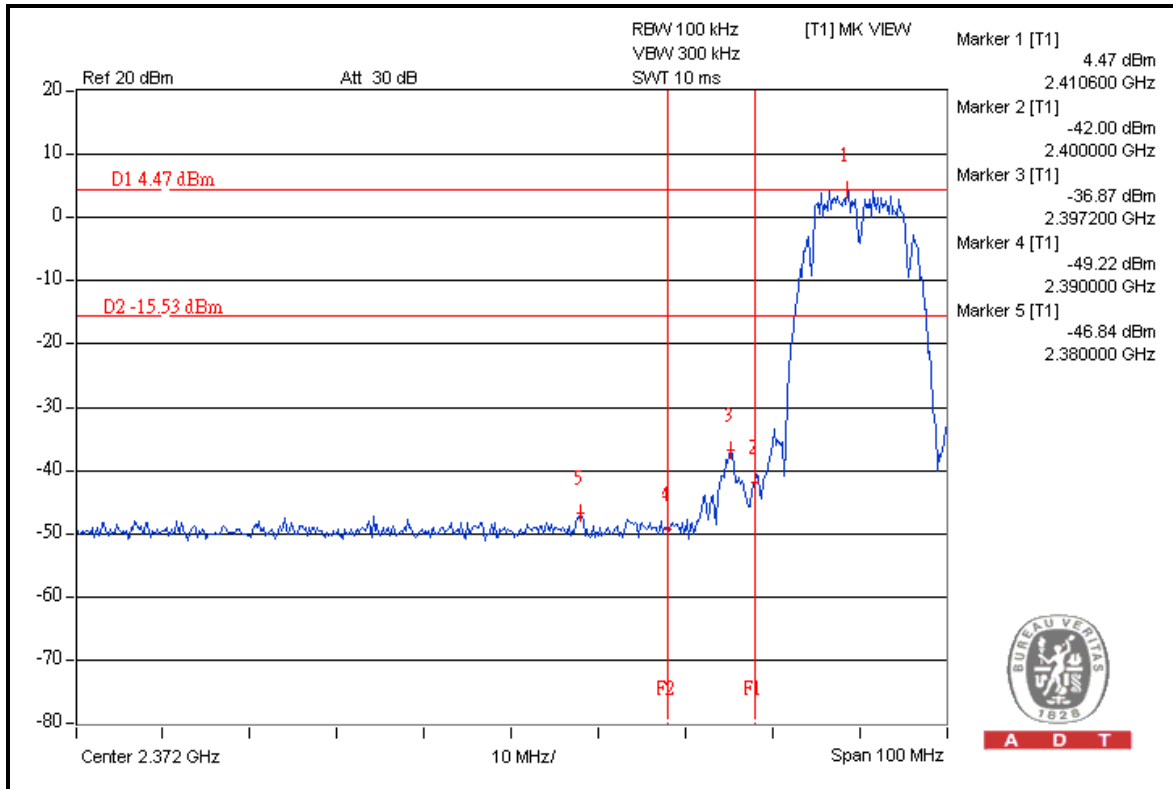



A D T

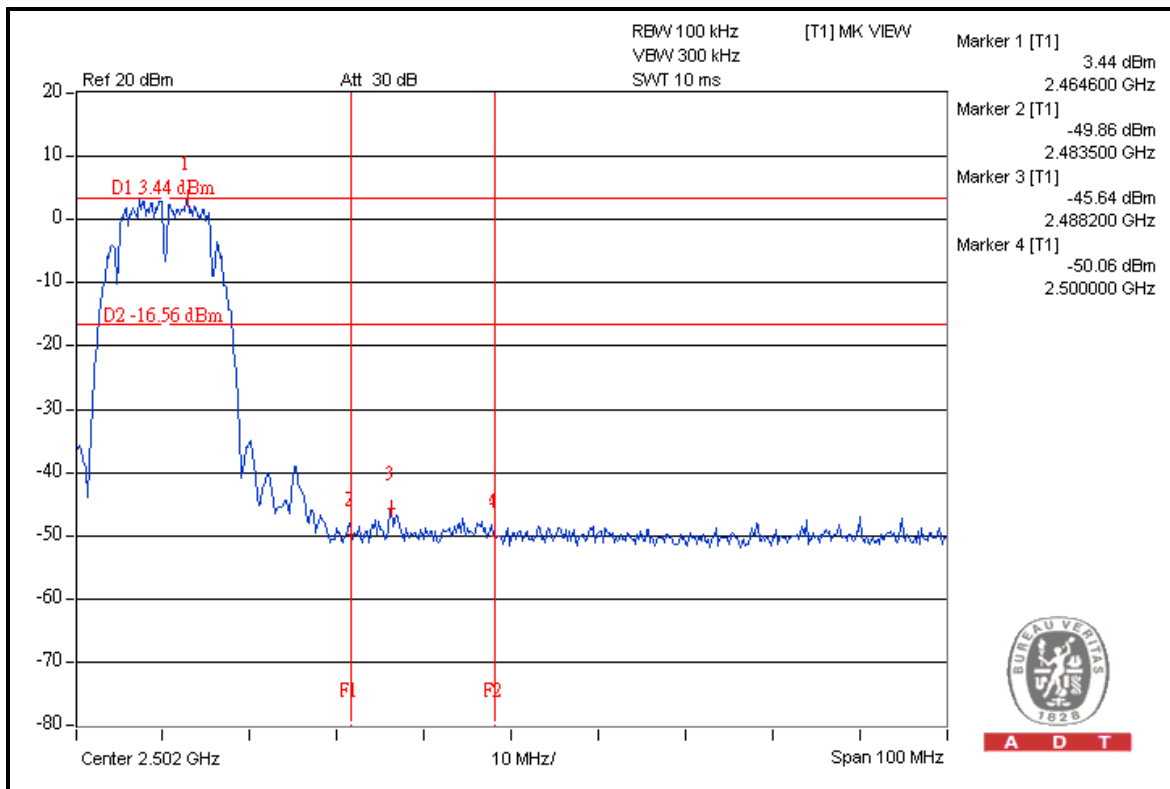
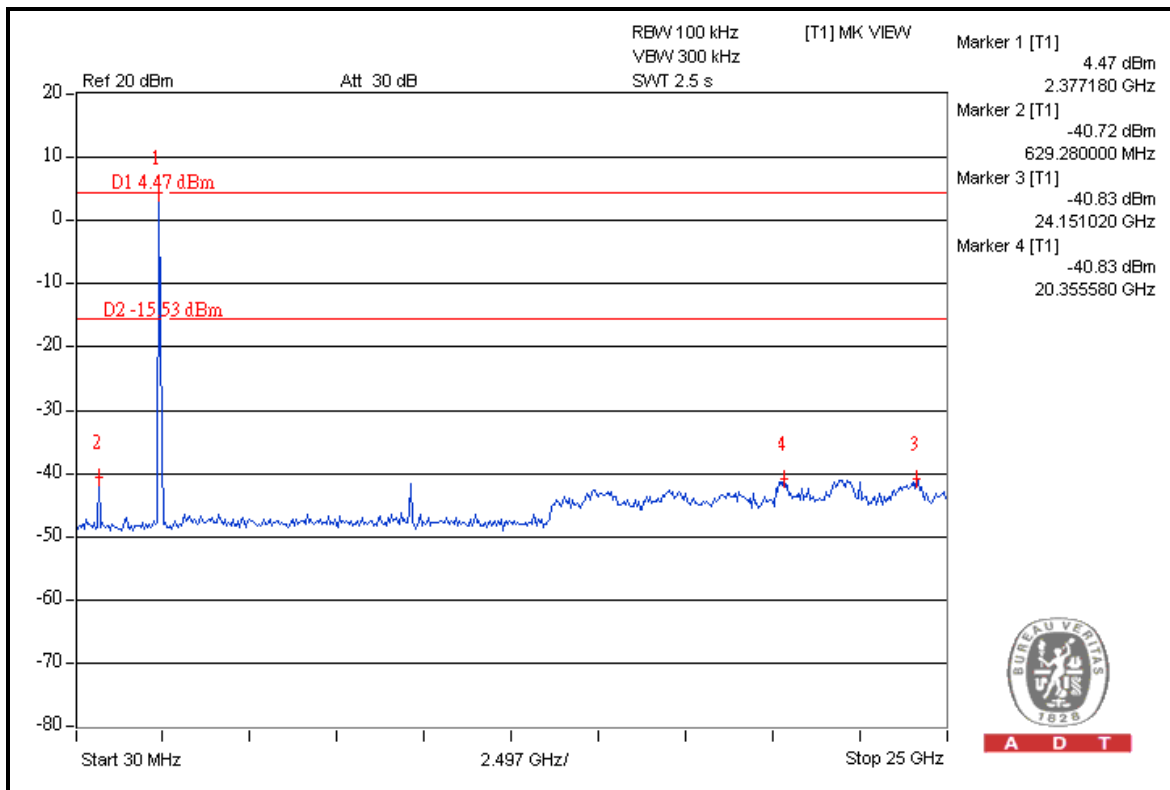



A D T

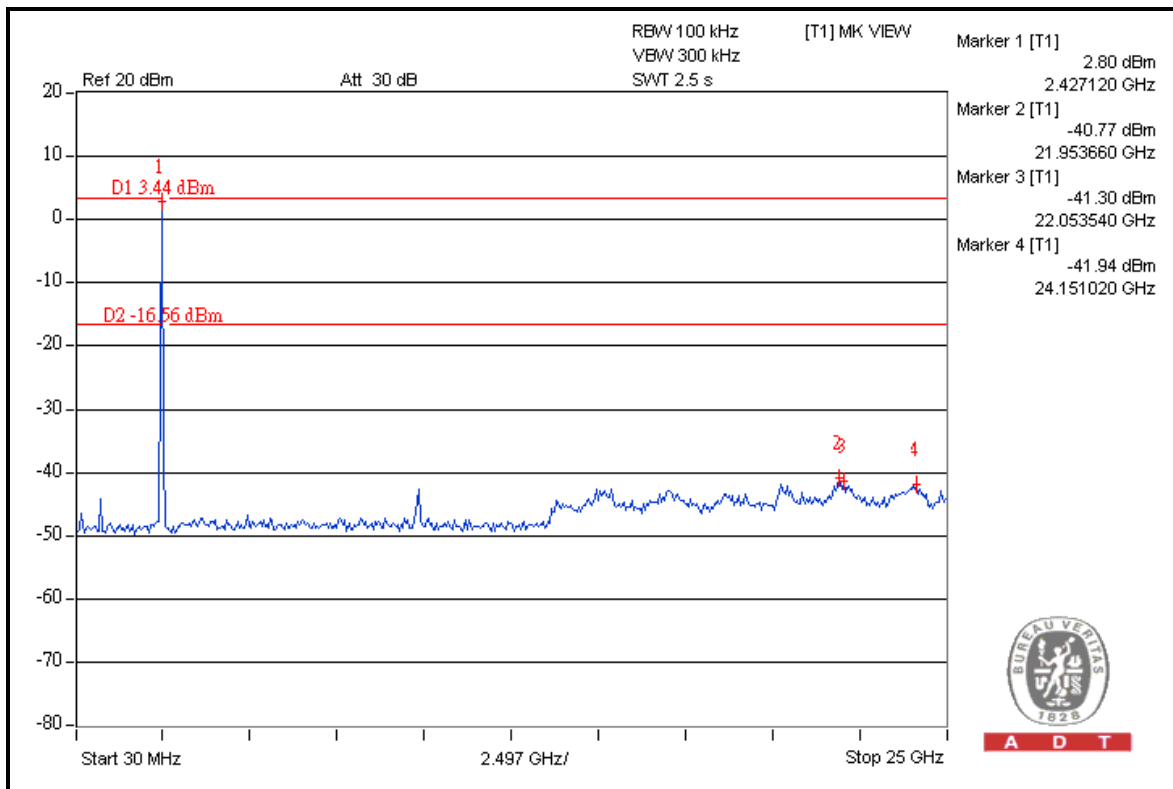
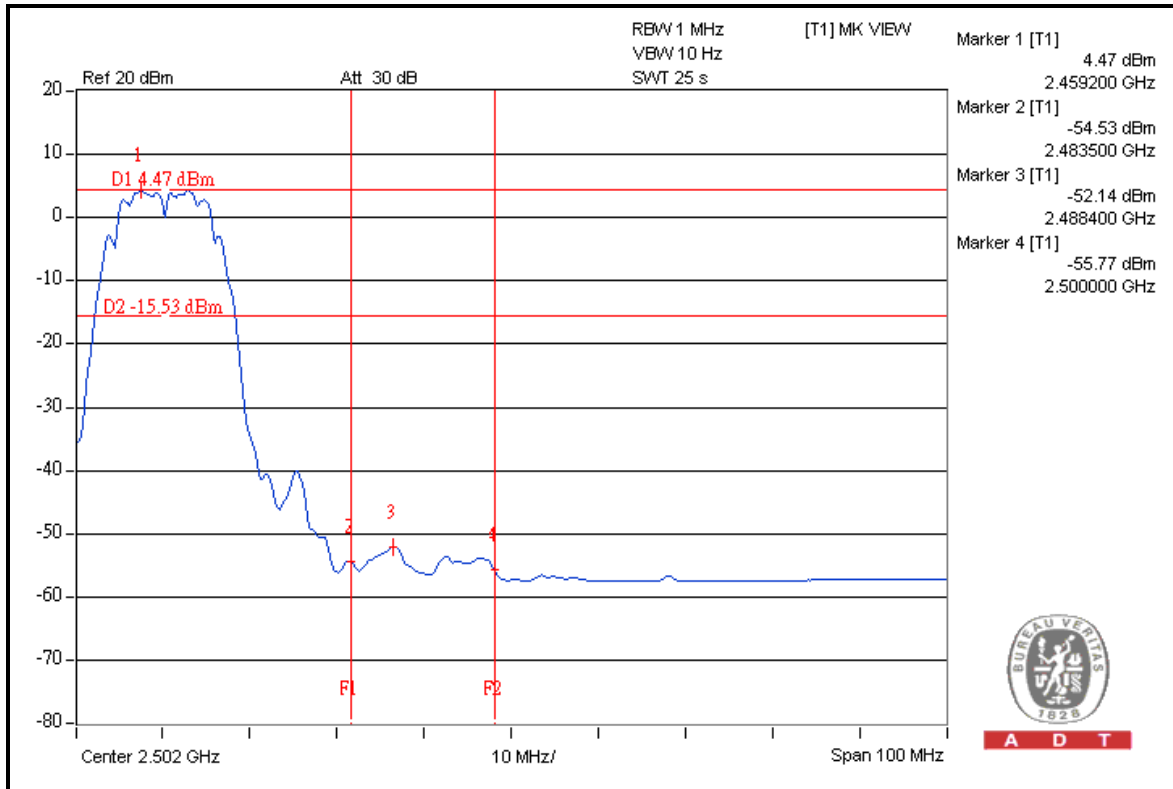



A D T

### 802.11g

#### RESTRICT BAND (2310 ~ 2390 MHz)

FREQUENCY (MHz)	FUNDAMENTAL EMISSION (dBuV/m)	DELTA (dB)	MAXIMUM FIELD STRENGTH IN RESTRICT BAND (dBuV/m)	LIMIT (dBuV/m)
2412.00 (PK)	107.6	43.0	64.6	74.00
2412.00 (AV)	95.9	47.5	48.4	54.00

#### RESTRICT BAND (2483.5 ~ 2500 MHz)

FREQUENCY (MHz)	FUNDAMENTAL EMISSION (dBuV/m)	DELTA (dB)	MAXIMUM FIELD STRENGTH IN RESTRICT BAND (dBuV/m)	LIMIT (dBuV/m)
2462.00 (PK)	108.1	45.0	63.1	74.00
2462.00 (AV)	96.7	48.4	48.3	54.00

#### NOTE:

1. Delta = Amplitude between the peak of the fundamental and the peak of the band edge emission. Please check following 3 pages.
2. Maximum field strength in restrict band = Fundamental emission – Delta.



A D T

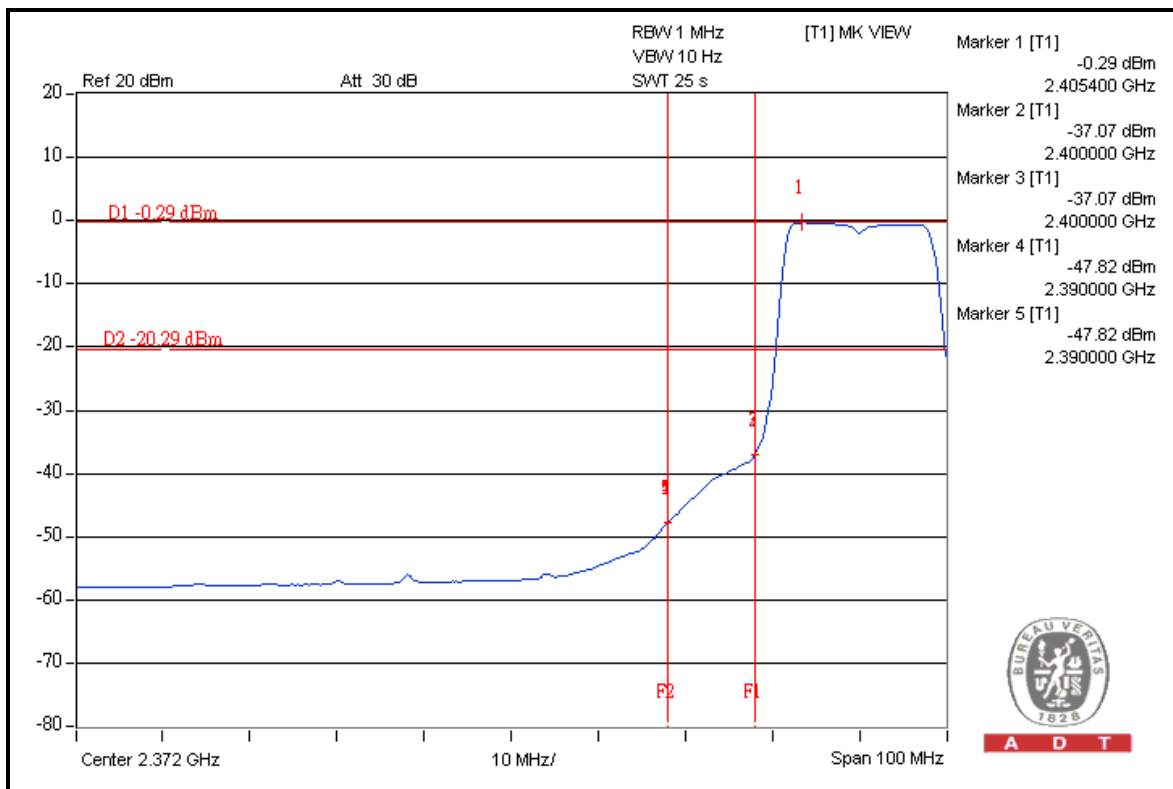
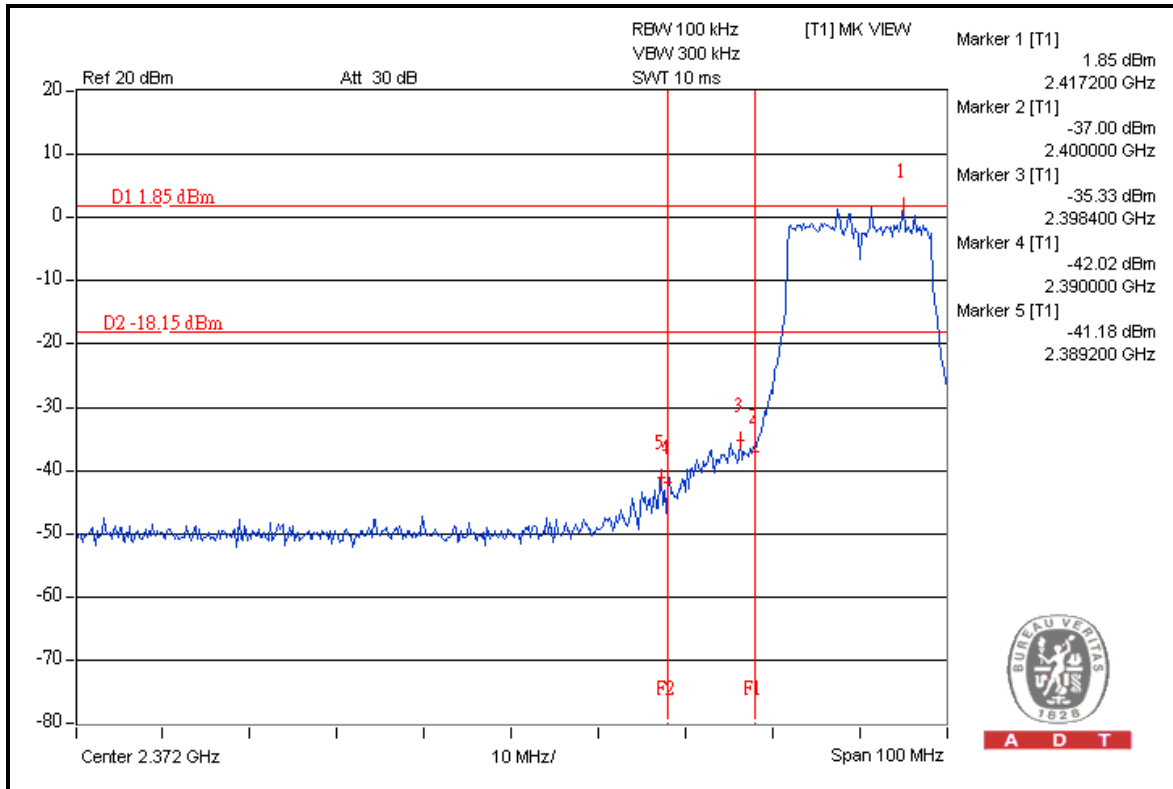



A D T

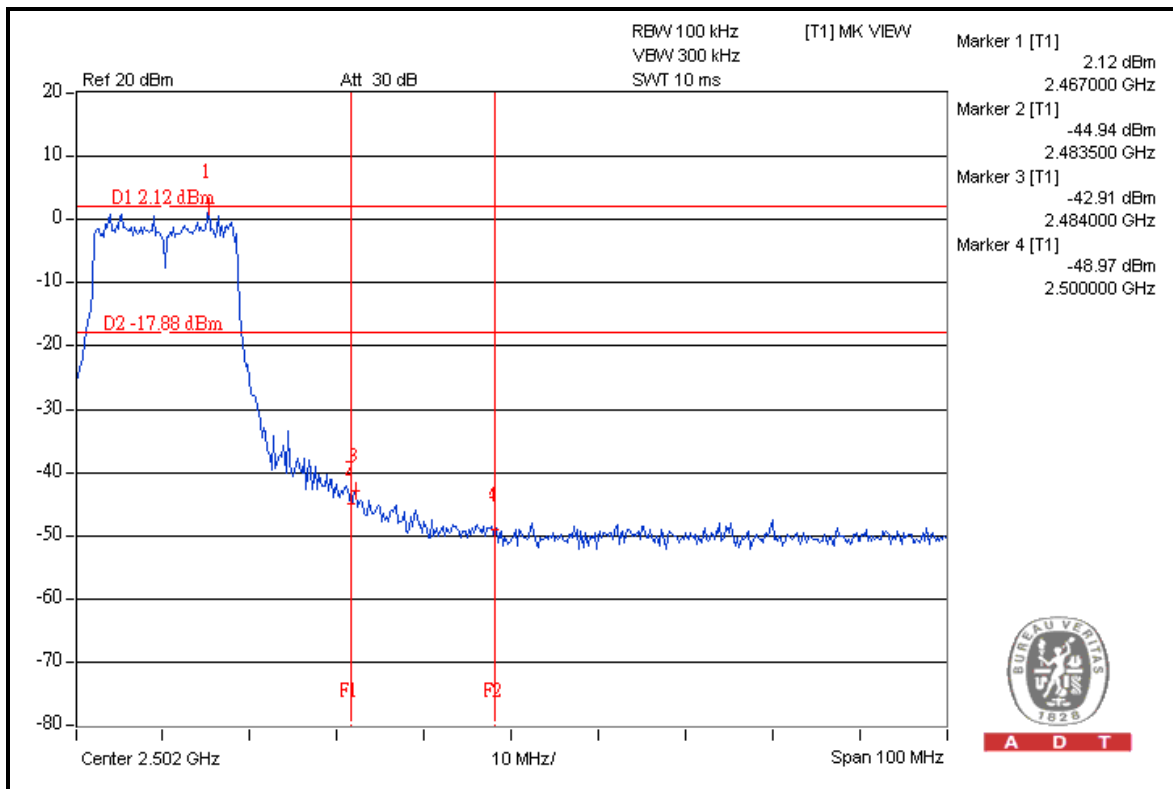
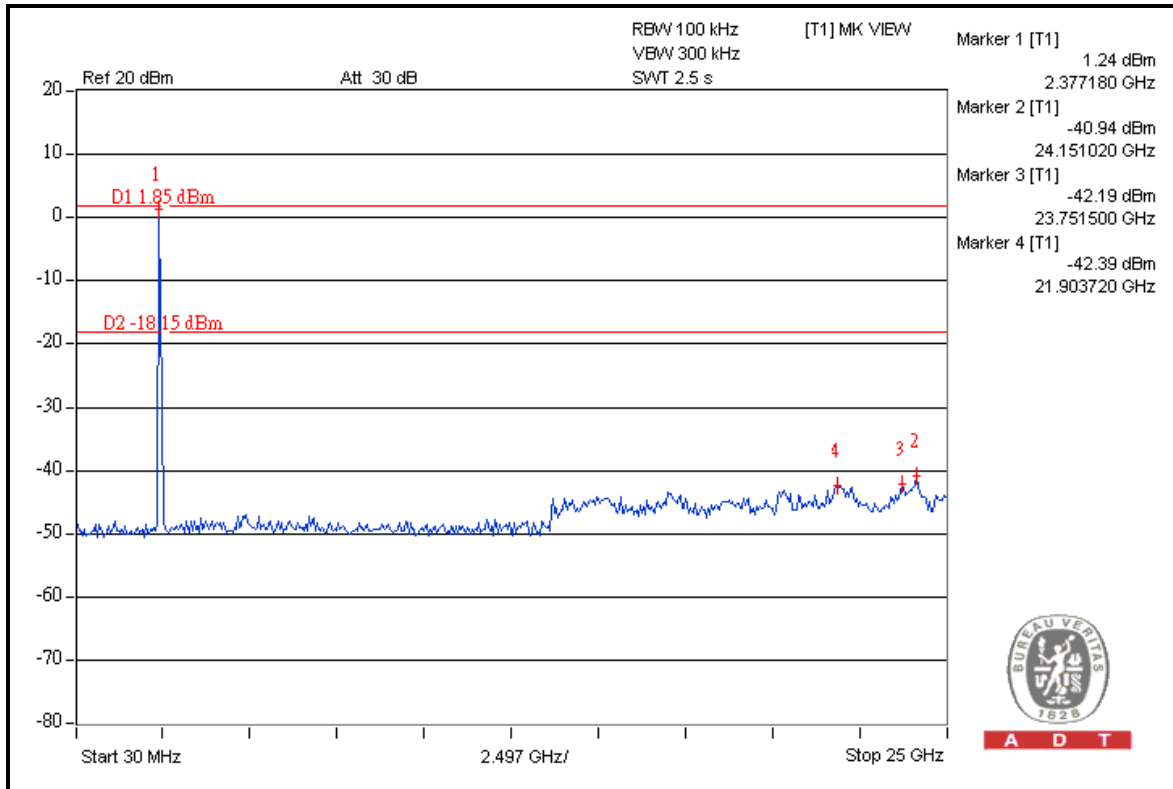





A D T

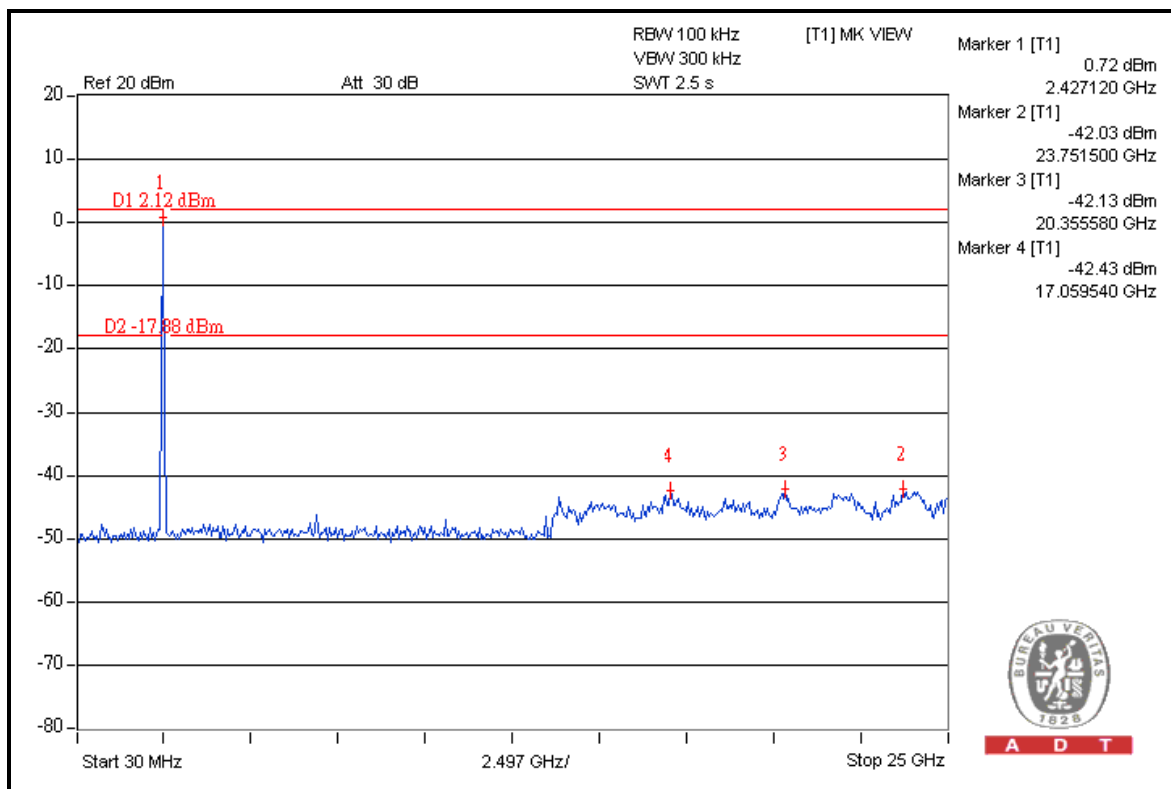
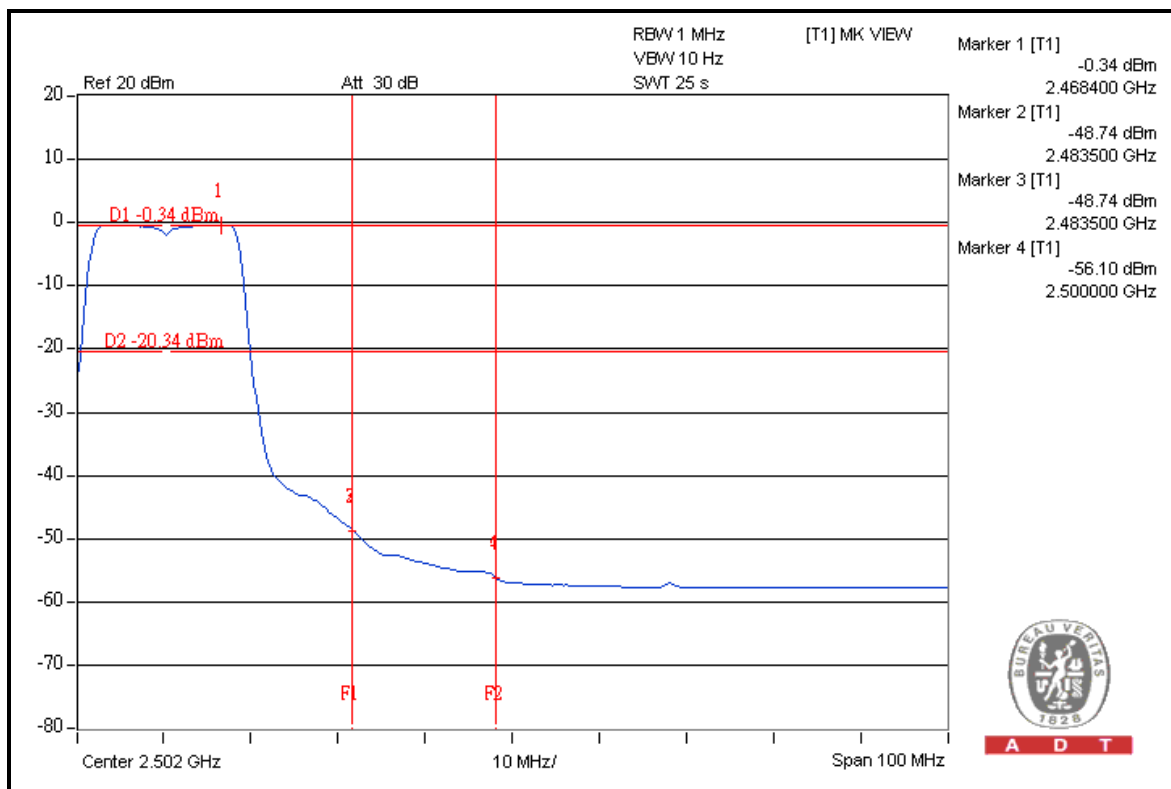



A D T

### 802.11n (20MHz)

#### RESTRICT BAND (2310 ~ 2390 MHz)

FREQUENCY (MHz)	FUNDAMENTAL EMISSION (dBuV/m)	DELTA (dB)	MAXIMUM FIELD STRENGTH IN RESTRICT BAND (dBuV/m)	LIMIT (dBuV/m)
2412.00 (PK)	107.0	43.3	63.7	74.00
2412.00 (AV)	95.5	45.0	50.5	54.00

#### RESTRICT BAND (2483.5 ~ 2500 MHz)

FREQUENCY (MHz)	FUNDAMENTAL EMISSION (dBuV/m)	DELTA (dB)	MAXIMUM FIELD STRENGTH IN RESTRICT BAND (dBuV/m)	LIMIT (dBuV/m)
2462.00 (PK)	108.1	43.2	64.9	74.00
2462.00 (AV)	96.4	46.7	49.7	54.00

#### NOTE:

1. Delta = Amplitude between the peak of the fundamental and the peak of the band edge emission. Please check following 3 pages.
2. Maximum field strength in restrict band = Fundamental emission – Delta.



A D T

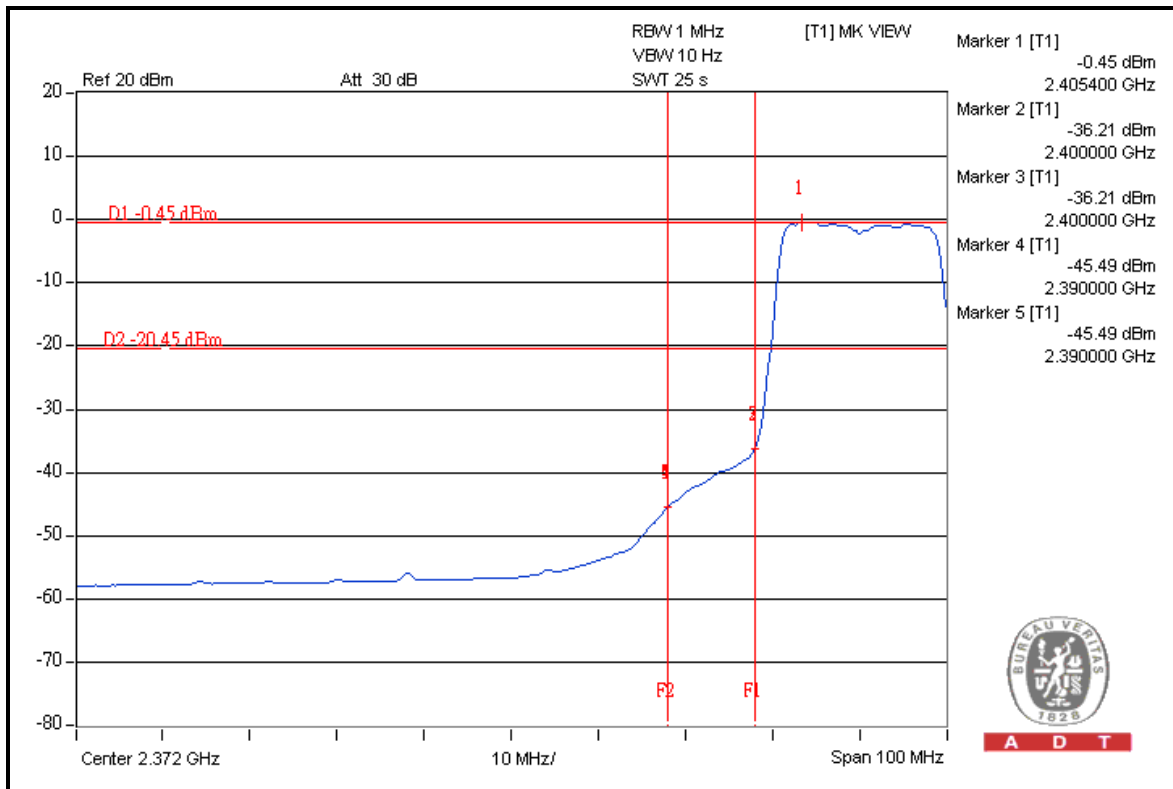
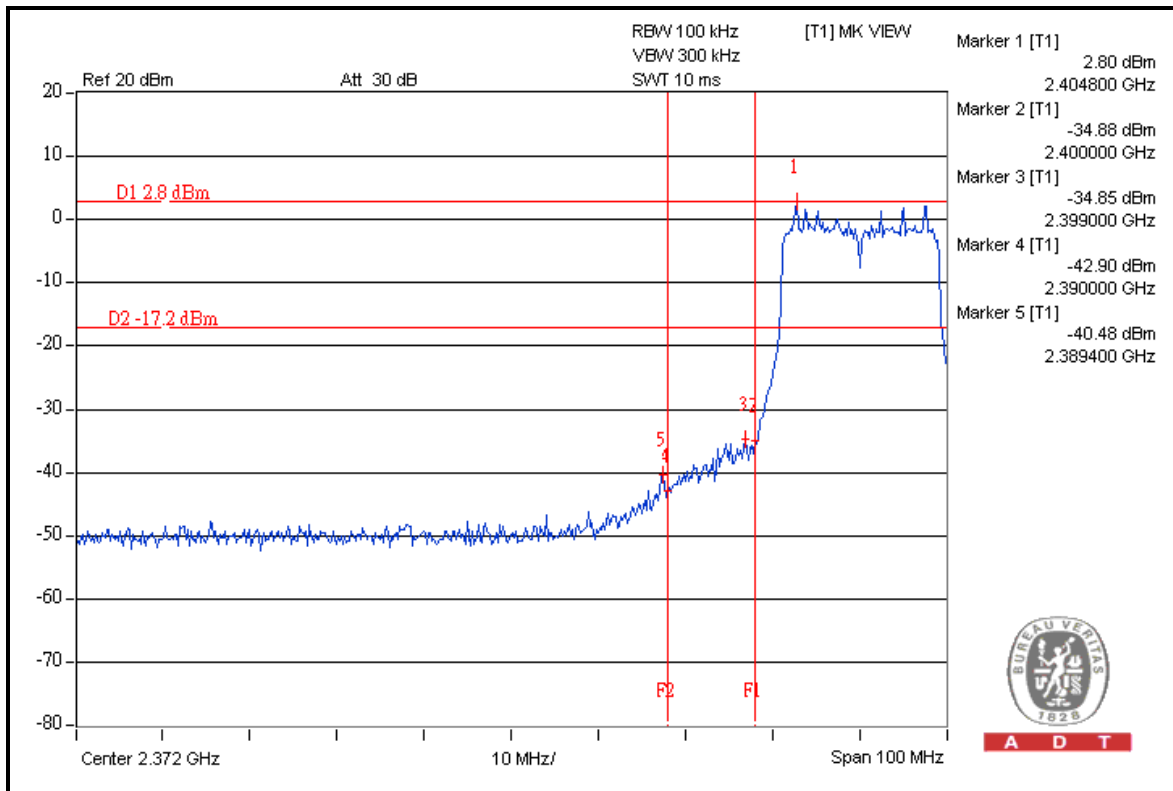



A D T

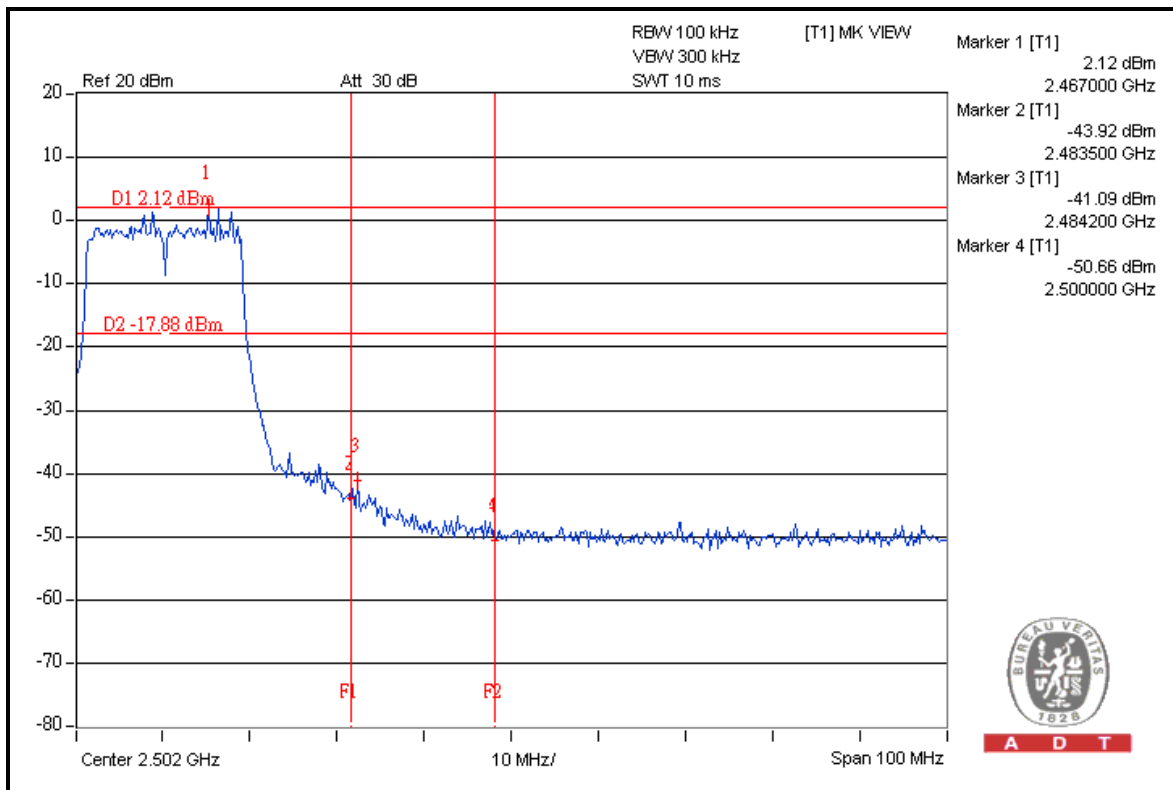
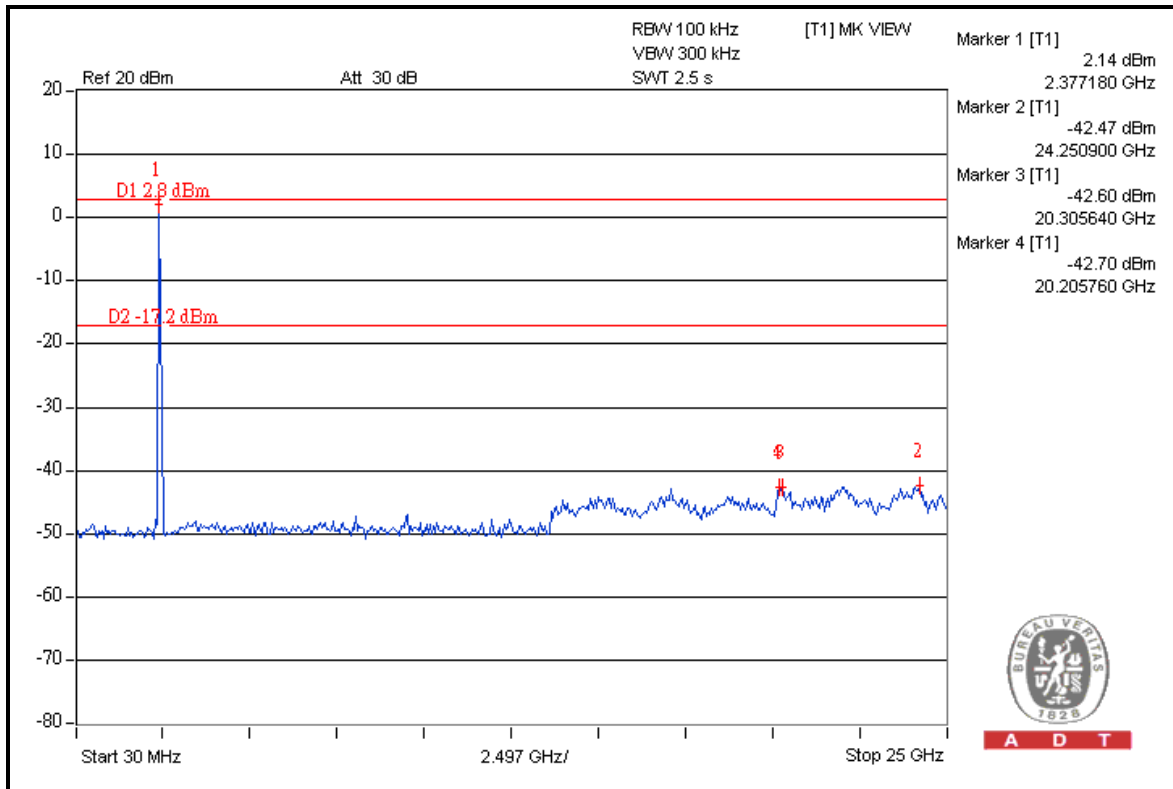



A D T

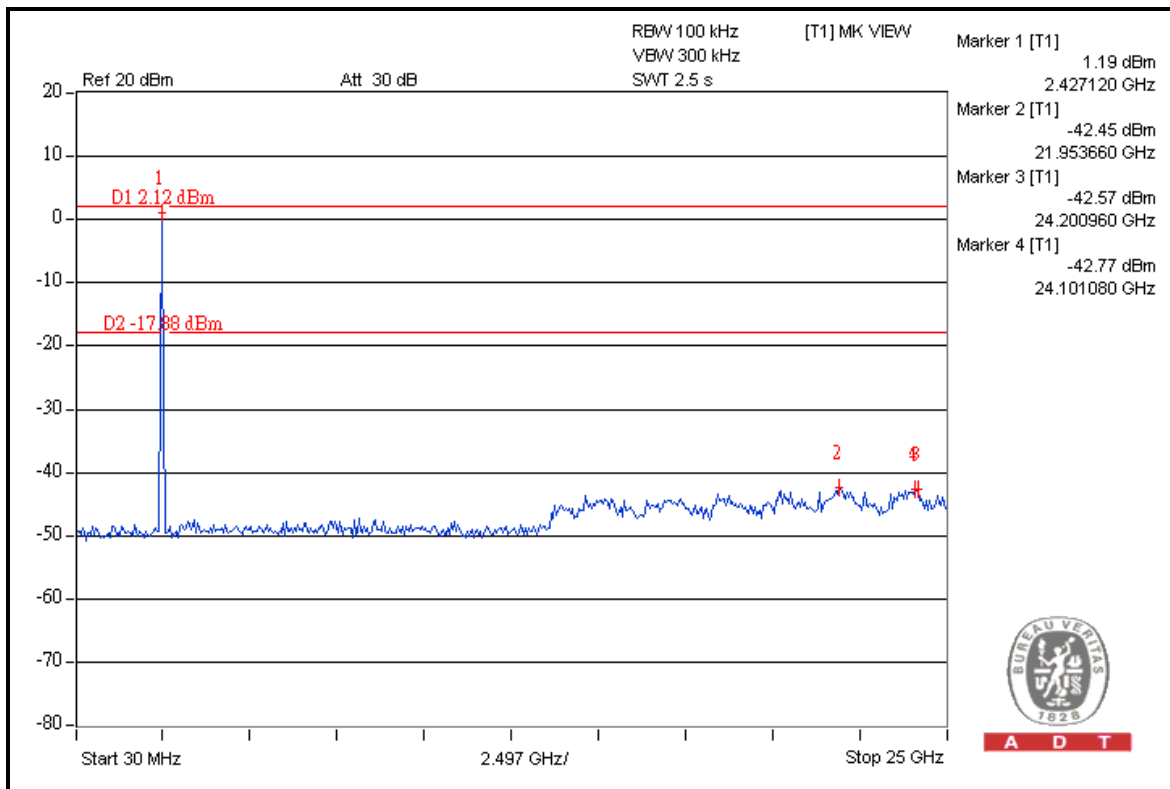
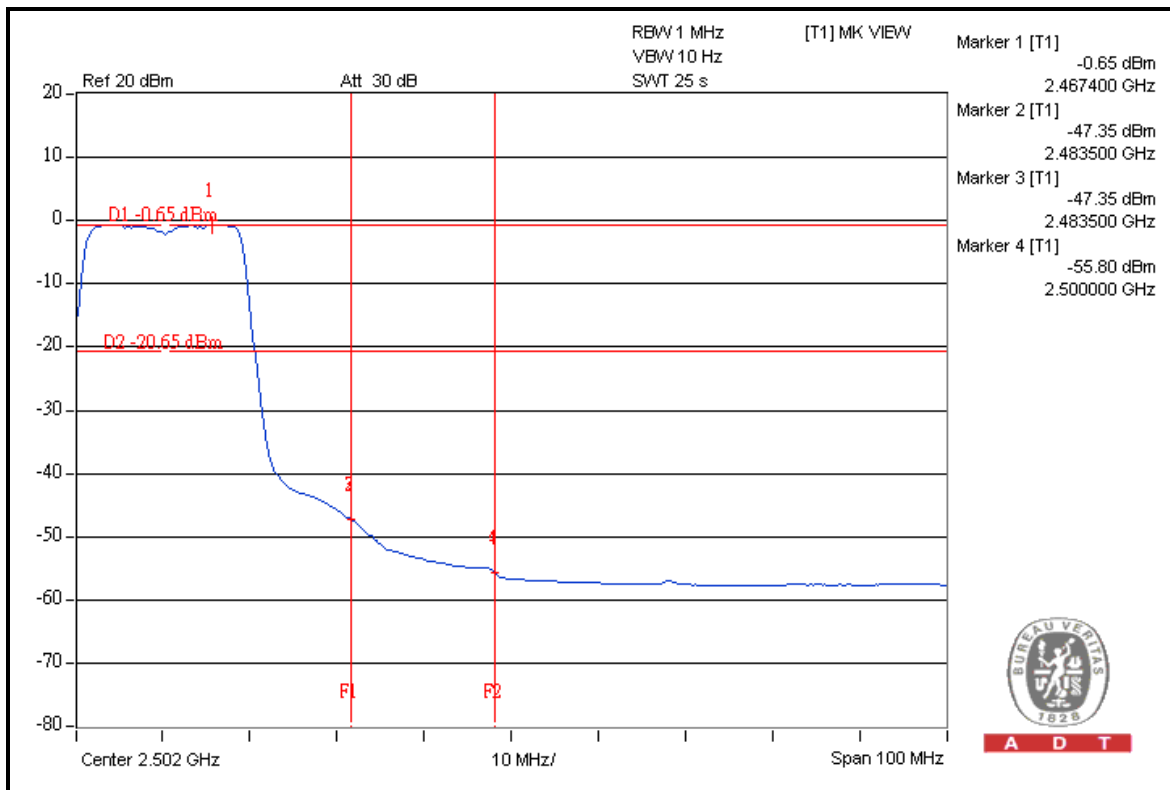



A D T

### 802.11n (40MHz)

#### RESTRICT BAND (2310 ~ 2390 MHz)

FREQUENCY (MHz)	FUNDAMENTAL EMISSION (dBuV/m)	DELTA (dB)	MAXIMUM FIELD STRENGTH IN RESTRICT BAND (dBuV/m)	LIMIT (dBuV/m)
2422.00 (PK)	105.4	34.6	70.8	74.00
2422.00 (AV)	86.3	32.9	53.4	54.00

#### RESTRICT BAND (2483.5 ~ 2500 MHz)

FREQUENCY (MHz)	FUNDAMENTAL EMISSION (dBuV/m)	DELTA (dB)	MAXIMUM FIELD STRENGTH IN RESTRICT BAND (dBuV/m)	LIMIT (dBuV/m)
2452.00 (PK)	102.7	38.7	64.0	74.00
2452.00 (AV)	84.9	35.3	49.6	54.00

#### NOTE:

1. Delta = Amplitude between the peak of the fundamental and the peak of the band edge emission. Please check following 3 pages.
2. Maximum field strength in restrict band = Fundamental emission – Delta.



A D T

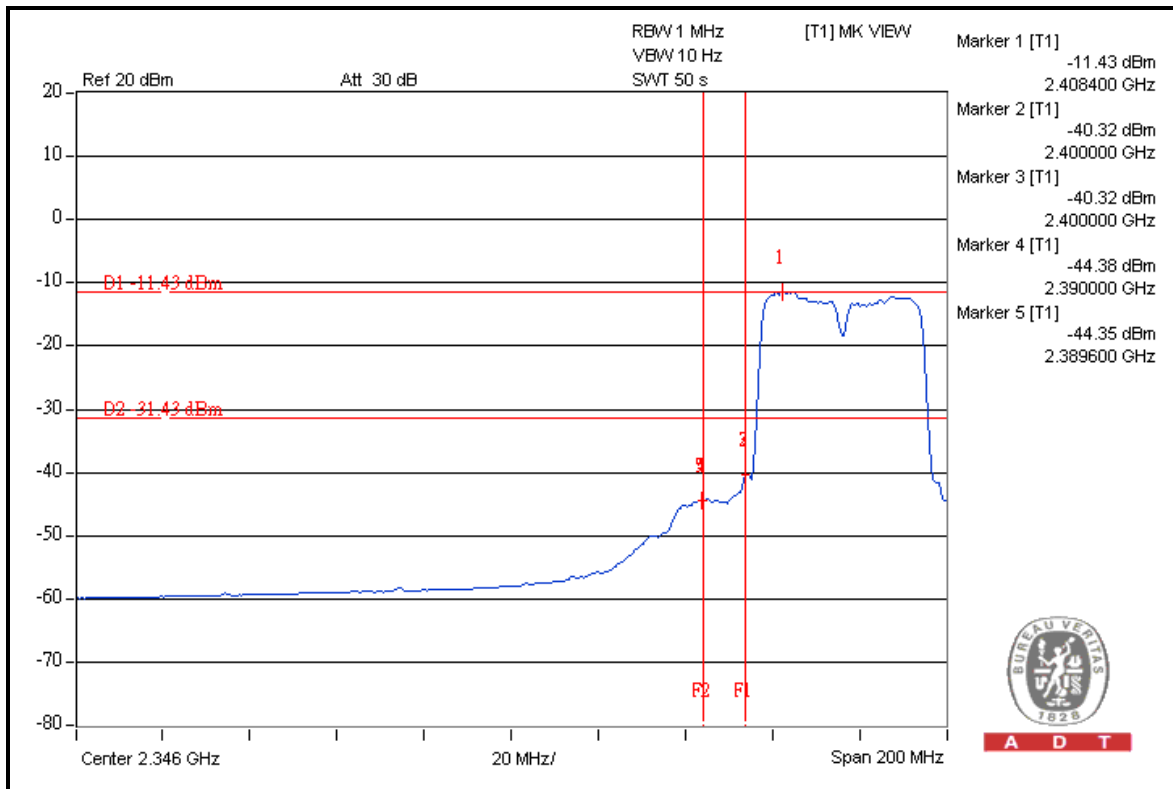
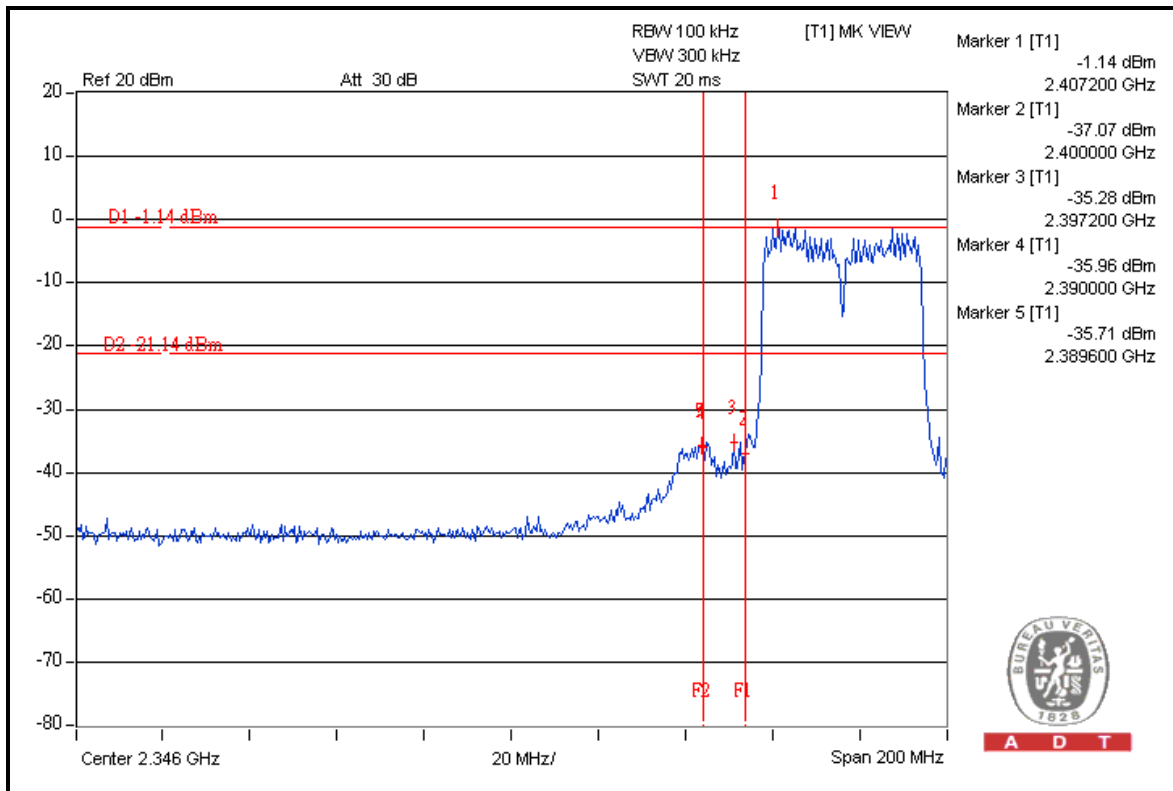



A D T

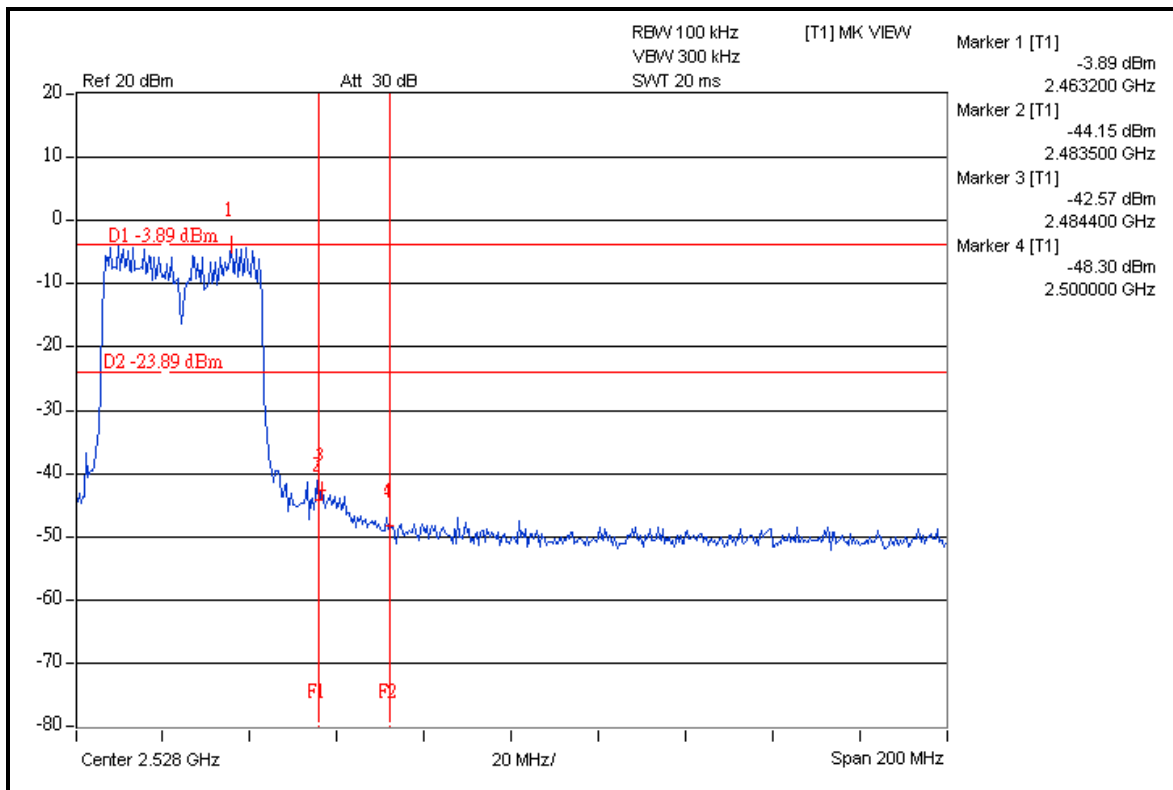
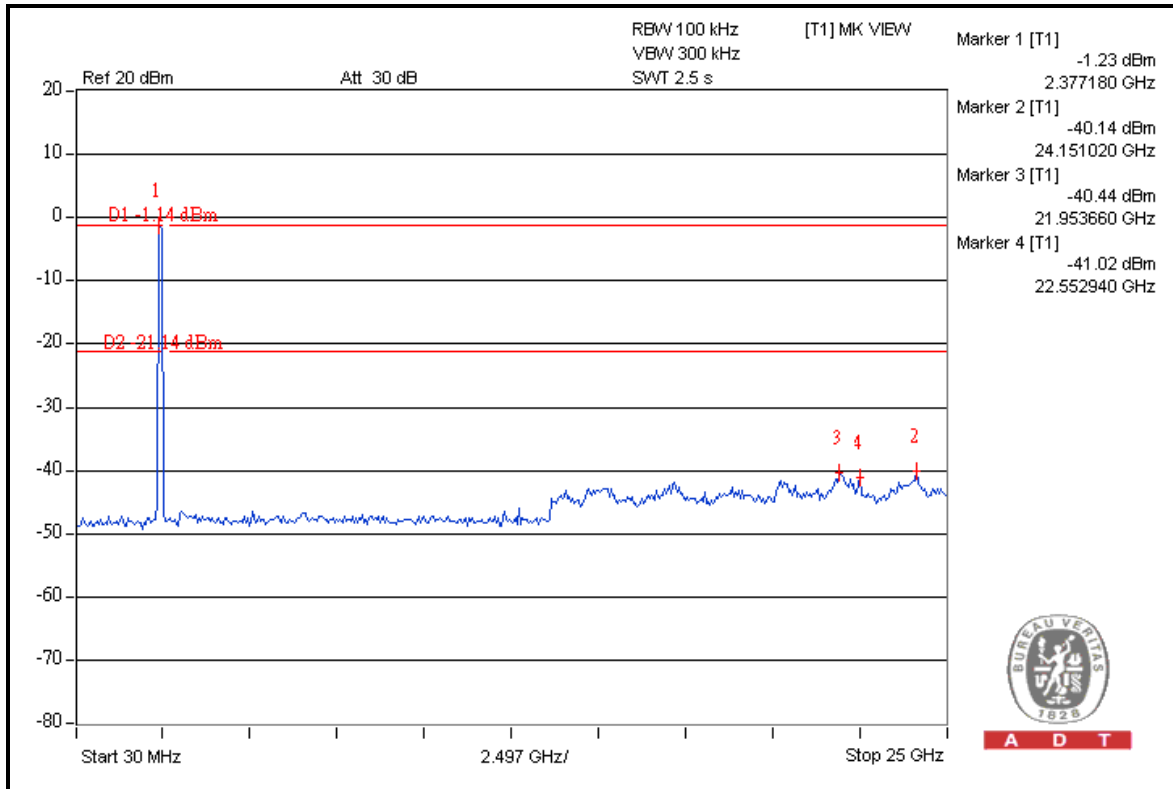





A D T

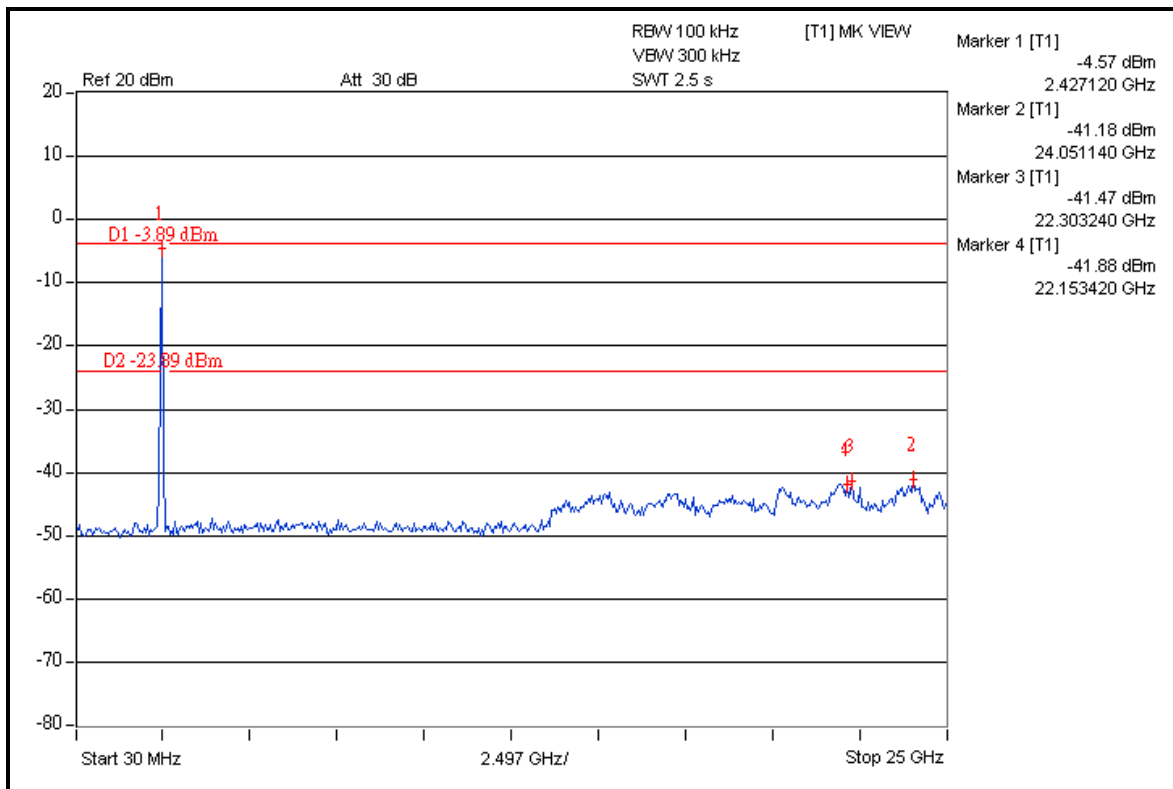
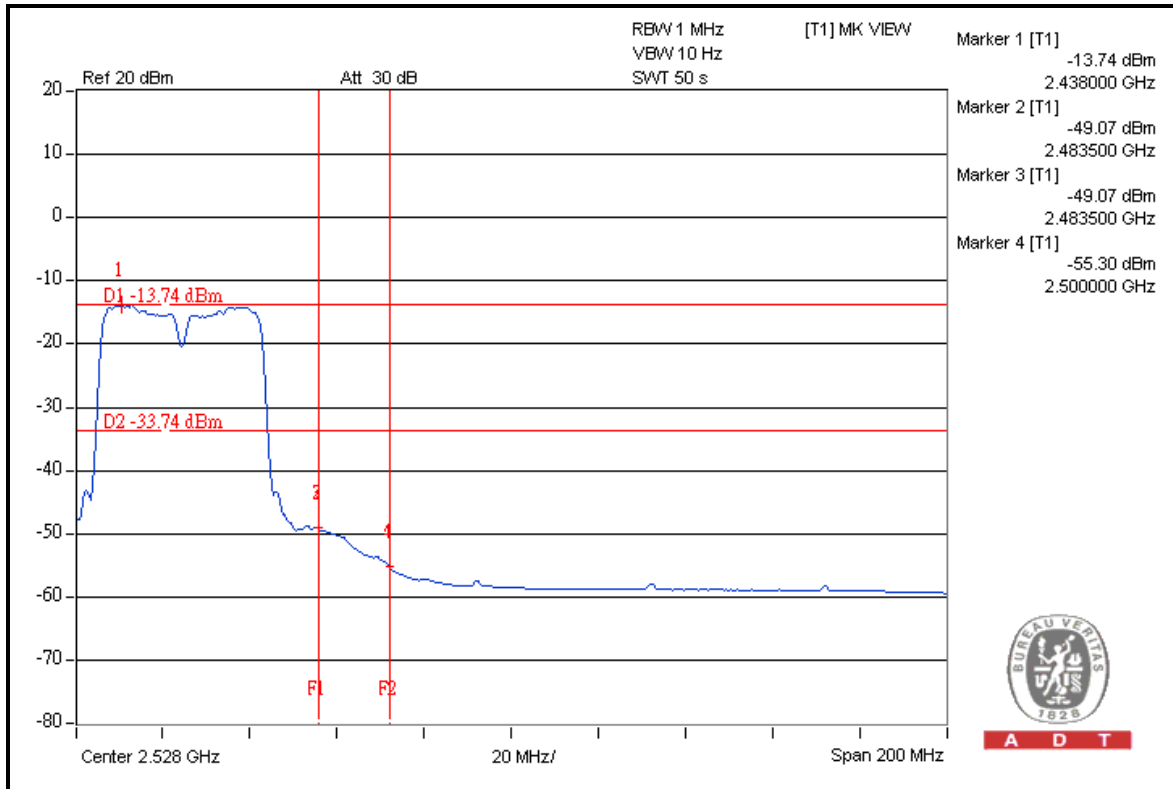



## 5. TEST TYPES AND RESULTS (FOR 5.0GHz BAND)

### 5.1 RADIATED EMISSION MEASUREMENT

#### 5.1.1 LIMITS OF RADIATED EMISSION MEASUREMENT

Emissions radiated outside of the specified bands, shall be according to the general radiated limits in 15.209 as following:

FREQUENCIES (MHz)	FIELD STRENGTH (microvolts/meter)	MEASUREMENT DISTANCE (meters)
0.009 ~ 0.490	2400/F(kHz)	300
0.490 ~ 1.705	24000/F(kHz)	30
1.705 ~ 30.0	30	30
30 ~ 88	100	3
88 ~ 216	150	3
216 ~ 960	200	3
Above 960	500	3

**NOTE:**

1. The lower limit shall apply at the transition frequencies.
2. Emission level (dBuV/m) = 20 log Emission level (uV/m).
3. As shown in 15.35(b), for frequencies above 1000MHz, the field strength limits are based on average detector, however, the peak field strength of any emission shall not exceed the maximum permitted average limits, specified above by more than 20dB under any condition of modulation.



A D T

## 5.1.2 TEST INSTRUMENTS

DESCRIPTION & MANUFACTURER	MODEL NO.	SERIAL NO.	CALIBRATED DATE	CALIBRATED UNTIL
HP Preamplifier	8447D	2432A03504	May 04, 2009	May 03, 2010
HP Preamplifier	8449B	3008A01924	Aug. 31, 2009	Aug. 30, 2010
HP Preamplifier	8449B	3008A01292	Aug. 10, 2009	Aug. 09, 2010
ROHDE & SCHWARZ TEST RECEIVER	ESU26	100005	Jun. 06, 2009	Jun. 05, 2010
Schwarzbeck Antenna	VULB 9168	137	Apr. 29, 2009	Apr. 28, 2010
Schwarzbeck Antenna	VHBA 9123	480	Apr. 21, 2009	Apr. 20, 2010
EMCO Horn Antenna	3115	6714	Oct. 26, 2009	Oct. 25, 2010
EMCO Horn Antenna	3115	9312-4192	Apr. 17, 2009	Apr. 16, 2010
ADT. Turn Table	TT100	0306	NA	NA
ADT. Tower	AT100	0306	NA	NA
Software	ADT_Radiated_V 7.6.15.9.2	NA	NA	NA
SUHNER RF cable	SF104-26.5	CABLE-CH6-17m -01	Aug. 20, 2009	Aug. 19, 2010
ROHDE & SCHWARZ Spectrum Analyzer	FSP 40	100036	Apr. 03, 2009	Apr. 02, 2010

- NOTE:** 1. The calibration interval of the above test instruments is 12/24 months. And the calibrations are traceable to NML/ROC and NIST/USA.
2. The horn antenna and HP preamplifier (model: 8449B) are used only for the measurement of emission frequency above 1GHz if tested.
3. The test was performed in Chamber No. 6.
4. The Industry Canada Reference No. IC 7450E-6.
5. The FCC Site Registration No. is 447212.



A D T

### 5.1.3 TEST PROCEDURES

- a. The EUT was placed on the top of a rotating table 0.8 meters above the ground at a 3 meters semi-anechoic chamber. The table was rotated 360 degrees to determine the position of the highest radiation.
- b. The EUT was set 3 meters away from the interference-receiving antenna, which was mounted on the top of a variable-height antenna tower.
- c. The antenna is a broadband antenna, and its height is varied from one meter to four meters above the ground to determine the maximum value of the field strength. Both horizontal and vertical polarizations of the antenna are set to make the measurement.
- d. For each suspected emission, the EUT was arranged to its worst case and then the antenna was tuned to heights from 1 meter to 4 meters and the rotatable table was turned from 0 degrees to 360 degrees to find the maximum reading.
- e. The test-receiver system was set to Peak Detect Function and Specified Bandwidth with Maximum Hold Mode.
- f. If the emission level of the EUT in peak mode was lower than the limit specified, then testing could be stopped and the peak values of the EUT would be reported. Otherwise the emissions would be re-tested one by one using peak, quasi-peak or average method as specified and then reported in a data sheet.

**NOTE:**

1. The resolution bandwidth and video bandwidth of test receiver/spectrum analyzer is 120kHz for Quasi-peak detection at frequency below 1GHz.
2. The resolution bandwidth of test receiver/spectrum analyzer is 100kHz and video bandwidth is 300kHz for Peak detection at frequency above 1GHz.
3. The resolution bandwidth of test receiver/spectrum analyzer is 1MHz and the video bandwidth is 10Hz for Average detection (AV) at frequency above 1GHz.
4. All modes of operation were investigated and the worst-case emissions are reported.

### 5.1.4 DEVIATION FROM TEST STANDARD

No deviation

### 5.1.5 TEST SETUP

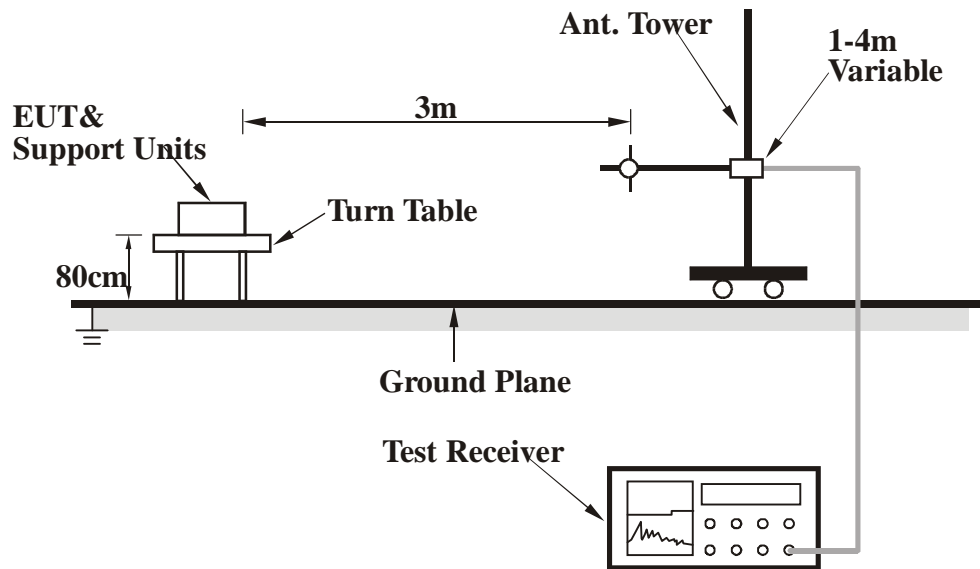

For the actual test configuration, please refer to the attached file (Test Setup Photo).

### 5.1.6 EUT OPERATING CONDITIONS

Same as 4.1.6



A D T

## 5.1.7 TEST RESULTS

### 802.11a OFDM MODULATION

EUT TEST CONDITION		MEASUREMENT DETAIL	
CHANNEL	Channel 149	FREQUENCY RANGE	1 ~ 40GHz
INPUT POWER	120Vac, 60Hz	DETECTOR FUNCTION	Peak (PK) Average (AV)
ENVIRONMENTAL CONDITIONS	23deg. C, 82% RH 1005hPa	TESTED BY	Nick Chen
TEST MODE	A		

ANTENNA POLARITY & TEST DISTANCE: HORIZONTAL AT 3 M								
NO.	FREQ. (MHz)	EMISSION LEVEL (dBuV/m)	LIMIT (dBuV/m)	MARGIN (dB)	ANTENNA HEIGHT (m)	TABLE ANGLE (Degree)	RAW VALUE (dBuV)	CORRECTION FACTOR (dB/m)
1	#5725.00	69.1 PK	82.8	-13.7	1.57 H	21	29.60	39.50
2	#5725.00	55.7 AV	71.5	-15.8	1.57 H	21	16.17	39.50
3	*5745.00	102.8 PK			1.57 H	21	63.24	39.54
4	*5745.00	91.5 AV			1.57 H	21	51.91	39.54
5	11490.00	68.0 PK	74.0	-6.0	1.26 H	301	18.61	49.37
6	11490.00	53.5 AV	54.0	-0.5	1.26 H	301	4.16	49.37
ANTENNA POLARITY & TEST DISTANCE: VERTICAL AT 3 M								
NO.	FREQ. (MHz)	EMISSION LEVEL (dBuV/m)	LIMIT (dBuV/m)	MARGIN (dB)	ANTENNA HEIGHT (m)	TABLE ANGLE (Degree)	RAW VALUE (dBuV)	CORRECTION FACTOR (dB/m)
1	#5725.00	69.0 PK	82.9	-13.9	1.06 V	97	29.48	39.50
2	#5725.00	55.9 AV	71.5	-15.5	1.06 V	97	16.44	39.50
3	*5745.00	102.9 PK			1.06 V	97	63.31	39.54
4	*5745.00	91.5 AV			1.06 V	97	51.92	39.54
5	11490.00	68.7 PK	74.0	-5.4	1.14 V	330	19.28	49.37
6	11490.00	53.9 AV	54.0	-0.1	1.14 V	330	4.53	49.37

- REMARKS:**
1. Emission level (dBuV/m) = Raw Value (dBuV) + Correction Factor (dB/m).
  2. Correction Factor (dB/m) = Antenna Factor (dB/m) + Cable Factor (dB).
  3. The other emission levels were very low against the limit.
  4. Margin value = Emission level – Limit value.
  5. “ \* “: Fundamental frequency.
  6. The limit value is defined as per 15.247.
  7. "#":The radiated frequency is out the restricted band.



A D T

EUT TEST CONDITION		MEASUREMENT DETAIL	
CHANNEL	Channel 157	FREQUENCY RANGE	1 ~ 40GHz
INPUT POWER	120Vac, 60Hz	DETECTOR FUNCTION	Peak (PK) Average (AV)
ENVIRONMENTAL CONDITIONS	23deg. C, 82% RH 1005hPa	TESTED BY	Nick Chen
TEST MODE	A		

ANTENNA POLARITY & TEST DISTANCE: HORIZONTAL AT 3 M								
NO.	FREQ. (MHz)	EMISSION LEVEL (dBuV/m)	LIMIT (dBuV/m)	MARGIN (dB)	ANTENNA HEIGHT (m)	TABLE ANGLE (Degree)	RAW VALUE (dBuV)	CORRECTION FACTOR (dB/m)
1	*5785.00	101.8 PK			1.56 H	18	62.14	39.62
2	*5785.00	89.7 AV			1.56 H	18	50.08	39.62
3	11570.00	64.9 PK	74.0	-9.1	1.22 H	348	15.47	49.44
4	11570.00	50.1 AV	54.0	-3.9	1.22 H	348	0.71	49.44
ANTENNA POLARITY & TEST DISTANCE: VERTICAL AT 3 M								
NO.	FREQ. (MHz)	EMISSION LEVEL (dBuV/m)	LIMIT (dBuV/m)	MARGIN (dB)	ANTENNA HEIGHT (m)	TABLE ANGLE (Degree)	RAW VALUE (dBuV)	CORRECTION FACTOR (dB/m)
1	*5785.00	101.9 PK			1.19 V	100	62.24	39.62
2	*5785.00	90.5 AV			1.19 V	100	50.83	39.62
3	11570.00	67.8 PK	74.0	-6.2	1.18 V	346	18.39	49.44
4	11570.00	53.0 AV	54.0	-1.0	1.18 V	346	3.53	49.44

- REMARKS:**
1. Emission level (dBuV/m) = Raw Value (dBuV) + Correction Factor (dB/m).
  2. Correction Factor (dB/m) = Antenna Factor (dB/m) + Cable Factor (dB).
  3. The other emission levels were very low against the limit.
  4. Margin value = Emission level – Limit value.
  5. “ \* ”: Fundamental frequency.
  6. The limit value is defined as per 15.247.



A D T

EUT TEST CONDITION		MEASUREMENT DETAIL	
CHANNEL	Channel 165	FREQUENCY RANGE	1 ~ 40GHz
INPUT POWER	120Vac, 60Hz	DETECTOR FUNCTION	Peak (PK) Average (AV)
ENVIRONMENTAL CONDITIONS	23deg. C, 82% RH 1005hPa	TESTED BY	Nick Chen
TEST MODE	A		

ANTENNA POLARITY & TEST DISTANCE: HORIZONTAL AT 3 M								
NO.	FREQ. (MHz)	EMISSION LEVEL (dBuV/m)	LIMIT (dBuV/m)	MARGIN (dB)	ANTENNA HEIGHT (m)	TABLE ANGLE (Degree)	RAW VALUE (dBuV)	CORRECTION FACTOR (dB/m)
1	*5825.00	104.1 PK			1.57 H	21	64.40	39.68
2	*5825.00	92.7 AV			1.57 H	21	53.01	39.68
3	#5850.00	68.3 PK	84.1	-15.8	1.57 H	21	28.55	39.70
4	#5850.00	55.4 AV	72.7	-17.3	1.57 H	21	15.65	39.70
5	11650.00	65.0 PK	74.0	-9.0	1.08 H	79	15.63	49.37
6	11650.00	49.8 AV	54.0	-4.2	1.08 H	79	0.47	49.37
ANTENNA POLARITY & TEST DISTANCE: VERTICAL AT 3 M								
NO.	FREQ. (MHz)	EMISSION LEVEL (dBuV/m)	LIMIT (dBuV/m)	MARGIN (dB)	ANTENNA HEIGHT (m)	TABLE ANGLE (Degree)	RAW VALUE (dBuV)	CORRECTION FACTOR (dB/m)
1	*5825.00	104.2 PK			1.18 V	99	64.56	39.68
2	*5825.00	92.9 AV			1.18 V	99	53.25	39.68
3	#5850.00	68.1 PK	84.2	-16.2	1.18 V	99	28.37	39.70
4	#5850.00	55.2 AV	72.9	-17.7	1.18 V	99	15.51	39.70
5	11650.00	69.1 PK	74.0	-4.9	1.18 V	13	19.73	49.37
6	11650.00	53.9 AV	54.0	-0.1	1.18 V	13	4.49	49.37

- REMARKS:**
1. Emission level (dBuV/m) = Raw Value (dBuV) + Correction Factor (dB/m).
  2. Correction Factor (dB/m) = Antenna Factor (dB/m) + Cable Factor (dB).
  3. The other emission levels were very low against the limit.
  4. Margin value = Emission level – Limit value.
  5. “ \* “: Fundamental frequency.
  6. The limit value is defined as per 15.247.
  7. “#”:The radiated frequency is out the restricted band.





A D T

**DRAFT 802.11n (20MHz)**

EUT TEST CONDITION		MEASUREMENT DETAIL	
CHANNEL	Channel 149	FREQUENCY RANGE	1 ~ 40GHz
INPUT POWER	120Vac, 60Hz	DETECTOR FUNCTION	Peak (PK) Average (AV)
ENVIRONMENTAL CONDITIONS	23deg. C, 82% RH 1005hPa	TESTED BY	Nick Chen
TEST MODE	A		

ANTENNA POLARITY & TEST DISTANCE: HORIZONTAL AT 3 M								
NO.	FREQ. (MHz)	EMISSION LEVEL (dBuV/m)	LIMIT (dBuV/m)	MARGIN (dB)	ANTENNA HEIGHT (m)	TABLE ANGLE (Degree)	RAW VALUE (dBuV)	CORRECTION FACTOR (dB/m)
1	#5725.00	71.3 PK	82.4	-11.1	1.59 H	19	31.77	39.50
2	#5725.00	56.8 AV	71.0	-14.2	1.59 H	19	17.32	39.50
3	*5745.00	102.4 PK			1.59 H	19	62.83	39.54
4	*5745.00	91.0 AV			1.59 H	19	51.41	39.54
5	11490.00	65.4 PK	74.0	-8.6	1.12 H	80	16.03	49.37
6	11490.00	50.9 AV	54.0	-3.1	1.12 H	80	1.49	49.37

ANTENNA POLARITY & TEST DISTANCE: VERTICAL AT 3 M								
NO.	FREQ. (MHz)	EMISSION LEVEL (dBuV/m)	LIMIT (dBuV/m)	MARGIN (dB)	ANTENNA HEIGHT (m)	TABLE ANGLE (Degree)	RAW VALUE (dBuV)	CORRECTION FACTOR (dB/m)
1	#5725.00	71.1 PK	82.7	-11.6	1.20 V	98	31.57	39.50
2	#5725.00	56.6 AV	71.3	-14.7	1.20 V	98	17.08	39.50
3	*5745.00	102.7 PK			1.20 V	98	63.17	39.54
4	*5745.00	91.3 AV			1.20 V	98	51.71	39.54
5	11490.00	68.8 PK	74.0	-5.2	1.09 V	358	19.43	49.37
6	11490.00	53.7 AV	54.0	-0.3	1.09 V	358	4.31	49.37

- REMARKS:**
1. Emission level (dBuV/m) = Raw Value (dBuV) + Correction Factor (dB/m).
  2. Correction Factor (dB/m) = Antenna Factor (dB/m) + Cable Factor (dB).
  3. The other emission levels were very low against the limit.
  4. Margin value = Emission level – Limit value.
  5. “ \* “: Fundamental frequency.
  6. The limit value is defined as per 15.247.
  7. "#":The radiated frequency is out the restricted band.



A D T

EUT TEST CONDITION		MEASUREMENT DETAIL	
CHANNEL	Channel 157	FREQUENCY RANGE	1 ~ 40GHz
INPUT POWER	120Vac, 60Hz	DETECTOR FUNCTION	Peak (PK) Average (AV)
ENVIRONMENTAL CONDITIONS	23deg. C, 82% RH 1005hPa	TESTED BY	Nick Chen
TEST MODE	A		

ANTENNA POLARITY & TEST DISTANCE: HORIZONTAL AT 3 M								
NO.	FREQ. (MHz)	EMISSION LEVEL (dBuV/m)	LIMIT (dBuV/m)	MARGIN (dB)	ANTENNA HEIGHT (m)	TABLE ANGLE (Degree)	RAW VALUE (dBuV)	CORRECTION FACTOR (dB/m)
1	*5785.00	103.1 PK			1.62 H	19	63.43	39.62
2	*5785.00	91.7 AV			1.62 H	19	52.03	39.62
3	11570.00	65.9 PK	74.0	-8.1	1.10 H	81	16.42	49.44
4	11570.00	50.4 AV	54.0	-3.6	1.10 H	81	0.92	49.44
ANTENNA POLARITY & TEST DISTANCE: VERTICAL AT 3 M								
NO.	FREQ. (MHz)	EMISSION LEVEL (dBuV/m)	LIMIT (dBuV/m)	MARGIN (dB)	ANTENNA HEIGHT (m)	TABLE ANGLE (Degree)	RAW VALUE (dBuV)	CORRECTION FACTOR (dB/m)
1	*5785.00	103.6 PK			1.06 V	97	64.01	39.62
2	*5785.00	92.0 AV			1.06 V	97	52.41	39.62
3	11570.00	69.1 PK	74.0	-4.9	1.06 V	347	19.68	49.44
4	11570.00	53.9 AV	54.0	-0.1	1.06 V	347	4.43	49.44

- REMARKS:**
1. Emission level (dBuV/m) = Raw Value (dBuV) + Correction Factor (dB/m).
  2. Correction Factor (dB/m) = Antenna Factor (dB/m) + Cable Factor (dB).
  3. The other emission levels were very low against the limit.
  4. Margin value = Emission level – Limit value.
  5. “ \* “: Fundamental frequency.
  6. The limit value is defined as per 15.247.



A D T

EUT TEST CONDITION		MEASUREMENT DETAIL	
CHANNEL	Channel 165	FREQUENCY RANGE	1 ~ 40GHz
INPUT POWER	120Vac, 60Hz	DETECTOR FUNCTION	Peak (PK) Average (AV)
ENVIRONMENTAL CONDITIONS	23deg. C, 82% RH 1005hPa	TESTED BY	Nick Chen
TEST MODE	A		

ANTENNA POLARITY & TEST DISTANCE: HORIZONTAL AT 3 M								
NO.	FREQ. (MHz)	EMISSION LEVEL (dBuV/m)	LIMIT (dBuV/m)	MARGIN (dB)	ANTENNA HEIGHT (m)	TABLE ANGLE (Degree)	RAW VALUE (dBuV)	CORRECTION FACTOR (dB/m)
1	*5825.00	104.7 PK			1.52 H	21	65.02	39.68
2	*5825.00	93.5 AV			1.52 H	21	53.86	39.68
3	#5850.00	68.3 PK	84.7	-16.4	1.52 H	21	28.61	39.70
4	#5850.00	56.1 AV	73.5	-17.4	1.52 H	21	16.41	39.70
5	11650.00	64.7 PK	74.0	-9.3	1.11 H	83	15.37	49.37
6	11650.00	50.6 AV	54.0	-3.4	1.11 H	83	1.23	49.37
ANTENNA POLARITY & TEST DISTANCE: VERTICAL AT 3 M								
NO.	FREQ. (MHz)	EMISSION LEVEL (dBuV/m)	LIMIT (dBuV/m)	MARGIN (dB)	ANTENNA HEIGHT (m)	TABLE ANGLE (Degree)	RAW VALUE (dBuV)	CORRECTION FACTOR (dB/m)
1	*5825.00	104.8 PK			1.04 V	98	65.10	39.68
2	*5825.00	93.4 AV			1.04 V	98	53.67	39.68
3	#5850.00	69.0 PK	84.8	-15.8	1.04 V	98	29.29	39.70
4	#5850.00	55.7 AV	73.4	-17.7	1.04 V	98	15.97	39.70
5	11650.00	69.0 PK	74.0	-5.0	1.12 V	15	19.61	49.37
6	11650.00	53.8 AV	54.0	-0.2	1.12 V	15	4.38	49.37

- REMARKS:**
1. Emission level (dBuV/m) = Raw Value (dBuV) + Correction Factor (dB/m).
  2. Correction Factor (dB/m) = Antenna Factor (dB/m) + Cable Factor (dB).
  3. The other emission levels were very low against the limit.
  4. Margin value = Emission level – Limit value.
  5. “ \* “: Fundamental frequency.
  6. The limit value is defined as per 15.247.
  7. "#":The radiated frequency is out the restricted band.



A D T

**DRAFT 802.11n (40MHz)**

EUT TEST CONDITION		MEASUREMENT DETAIL	
CHANNEL	Channel 151	FREQUENCY RANGE	1 ~ 40GHz
INPUT POWER	120Vac, 60Hz	DETECTOR FUNCTION	Peak (PK) Average (AV)
ENVIRONMENTAL CONDITIONS	23deg. C, 82% RH 1005hPa	TESTED BY	Nick Chen
TEST MODE	A		

ANTENNA POLARITY & TEST DISTANCE: HORIZONTAL AT 3 M								
NO.	FREQ. (MHz)	EMISSION LEVEL (dBuV/m)	LIMIT (dBuV/m)	MARGIN (dB)	ANTENNA HEIGHT (m)	TABLE ANGLE (Degree)	RAW VALUE (dBuV)	CORRECTION FACTOR (dB/m)
1	#5725.00	76.1 PK	82.7	-6.6	1.56 H	16	36.62	39.50
2	#5725.00	58.8 AV	66.7	-7.9	1.56 H	16	19.28	39.50
3	*5755.00	102.7 PK			1.56 H	16	63.12	39.56
4	*5755.00	86.7 AV			1.56 H	16	47.11	39.56
5	11510.00	66.0 PK	74.0	-8.0	1.23 H	352	16.64	49.37
6	11510.00	51.5 AV	54.0	-2.5	1.23 H	352	2.14	49.37

ANTENNA POLARITY & TEST DISTANCE: VERTICAL AT 3 M								
NO.	FREQ. (MHz)	EMISSION LEVEL (dBuV/m)	LIMIT (dBuV/m)	MARGIN (dB)	ANTENNA HEIGHT (m)	TABLE ANGLE (Degree)	RAW VALUE (dBuV)	CORRECTION FACTOR (dB/m)
1	#5725.00	76.9 PK	84.0	-7.1	1.20 V	100	37.42	39.50
2	#5725.00	59.9 AV	68.0	-8.1	1.20 V	100	20.37	39.50
3	*5755.00	104.0 PK			1.20 V	100	64.41	39.56
4	*5755.00	88.0 AV			1.20 V	100	48.40	39.56
5	11510.00	68.7 PK	74.0	-5.3	1.13 V	2	19.32	49.37
6	11510.00	53.5 AV	54.0	-0.5	1.13 V	2	4.10	49.37

- REMARKS:**
1. Emission level (dBuV/m) = Raw Value (dBuV) + Correction Factor (dB/m).
  2. Correction Factor (dB/m) = Antenna Factor (dB/m) + Cable Factor (dB).
  3. The other emission levels were very low against the limit.
  4. Margin value = Emission level – Limit value.
  5. “ \* “: Fundamental frequency.
  6. The limit value is defined as per 15.247.
  7. "#":The radiated frequency is out the restricted band.



A D T

EUT TEST CONDITION		MEASUREMENT DETAIL	
CHANNEL	Channel 159	FREQUENCY RANGE	1 ~ 40GHz
INPUT POWER	120Vac, 60Hz	DETECTOR FUNCTION	Peak (PK) Average (AV)
ENVIRONMENTAL CONDITIONS	23deg. C, 82% RH 1005hPa	TESTED BY	Nick Chen
TEST MODE	A		

ANTENNA POLARITY & TEST DISTANCE: HORIZONTAL AT 3 M								
NO.	FREQ. (MHz)	EMISSION LEVEL (dBuV/m)	LIMIT (dBuV/m)	MARGIN (dB)	ANTENNA HEIGHT (m)	TABLE ANGLE (Degree)	RAW VALUE (dBuV)	CORRECTION FACTOR (dB/m)
1	*5795.00	103.0 PK			1.55 H	19	63.33	39.64
2	*5795.00	87.1 AV			1.55 H	19	47.42	39.64
3	#5850.00	67.8 PK	83.0	-15.2	1.55 H	19	28.13	39.70
4	#5850.00	55.4 AV	67.1	-11.7	1.55 H	19	15.70	39.70
5	11590.00	64.5 PK	74.0	-9.5	1.17 H	300	15.00	49.46
6	11590.00	51.0 AV	54.0	-3.0	1.17 H	300	1.53	49.46
ANTENNA POLARITY & TEST DISTANCE: VERTICAL AT 3 M								
NO.	FREQ. (MHz)	EMISSION LEVEL (dBuV/m)	LIMIT (dBuV/m)	MARGIN (dB)	ANTENNA HEIGHT (m)	TABLE ANGLE (Degree)	RAW VALUE (dBuV)	CORRECTION FACTOR (dB/m)
1	*5795.00	104.8 PK			1.18 V	100	65.12	39.64
2	*5795.00	88.1 AV			1.18 V	100	48.46	39.64
3	#5850.00	67.5 PK	84.8	-17.3	1.18 V	100	27.75	39.70
4	#5850.00	55.4 AV	68.1	-12.7	1.18 V	100	15.67	39.70
5	11590.00	68.0 PK	74.0	-6.0	1.24 V	5	18.53	49.46
6	11590.00	52.8 AV	54.0	-1.2	1.24 V	5	3.32	49.46

- REMARKS:**
1. Emission level (dBuV/m) = Raw Value (dBuV) + Correction Factor (dB/m).
  2. Correction Factor (dB/m) = Antenna Factor (dB/m) + Cable Factor (dB).
  3. The other emission levels were very low against the limit.
  4. Margin value = Emission level – Limit value.
  5. “ \* “: Fundamental frequency.
  6. The limit value is defined as per 15.247.
  7. “#”:The radiated frequency is out the restricted band.



A D T

**BELOW 1GHz WORST-CASE DATA : 802.11n (20MHz)**

EUT TEST CONDITION		MEASUREMENT DETAIL	
CHANNEL	Channel 165	FREQUENCY RANGE	Below 1000MHz
INPUT POWER	120Vac, 60Hz	DETECTOR FUNCTION	Quasi-Peak
ENVIRONMENTAL CONDITIONS	23deg. C, 83% RH 1005hPa	TESTED BY	Nick Chen
TEST MODE	A		

ANTENNA POLARITY & TEST DISTANCE: HORIZONTAL AT 3 M								
NO.	FREQ. (MHz)	EMISSION LEVEL (dBuV/m)	LIMIT (dBuV/m)	MARGIN (dB)	ANTENNA HEIGHT (m)	TABLE ANGLE (Degree)	RAW VALUE (dBuV)	CORRECTION FACTOR (dB/m)
1	56.43	38.4 QP	40.0	-1.7	1.02 H	283	25.60	12.75
2	148.14	32.2 QP	43.5	-11.3	1.12 H	319	17.90	14.26
3	264.73	29.7 QP	46.0	-16.3	1.32 H	10	15.98	13.72
4	678.22	30.9 QP	46.0	-15.1	1.37 H	349	6.42	24.47
5	762.16	29.1 QP	46.0	-16.9	1.14 H	22	3.12	25.99
6	866.31	32.8 QP	46.0	-13.2	1.02 H	277	5.16	27.61
7	900.51	33.8 QP	46.0	-12.2	1.00 H	103	5.77	28.05
ANTENNA POLARITY & TEST DISTANCE: VERTICAL AT 3 M								
NO.	FREQ. (MHz)	EMISSION LEVEL (dBuV/m)	LIMIT (dBuV/m)	MARGIN (dB)	ANTENNA HEIGHT (m)	TABLE ANGLE (Degree)	RAW VALUE (dBuV)	CORRECTION FACTOR (dB/m)
1	56.43	38.9 QP	40.0	-1.1	1.11 V	25	26.18	12.75
2	67.31	31.6 QP	40.0	-8.4	1.01 V	274	19.25	12.35
3	148.14	29.1 QP	43.5	-14.4	1.35 V	97	14.88	14.26
4	365.77	29.9 QP	46.0	-16.1	1.27 V	244	12.73	17.15
5	533.65	31.9 QP	46.0	-14.1	1.05 V	298	10.04	21.84
6	773.04	32.3 QP	46.0	-13.7	1.27 V	40	6.11	26.17
7	797.92	32.3 QP	46.0	-13.7	1.06 V	58	5.69	26.58
8	900.51	33.8 QP	46.0	-12.2	1.25 V	355	5.75	28.05

- REMARKS:**
1. Emission level (dBuV/m) = Raw Value (dBuV) + Correction Factor (dB/m).
  2. Correction Factor (dB/m) = Antenna Factor (dB/m) + Cable Factor (dB).
  3. The other emission levels were very low against the limit.
  4. Margin value = Emission level – Limit value.



A D T

EUT TEST CONDITION		MEASUREMENT DETAIL	
CHANNEL	Channel 165	FREQUENCY RANGE	Below 1000MHz
INPUT POWER	7.4Vdc	DETECTOR FUNCTION	Quasi-Peak
ENVIRONMENTAL CONDITIONS	23deg. C, 83% RH 1005hPa	TESTED BY	Nick Chen
TEST MODE	B		

ANTENNA POLARITY & TEST DISTANCE: HORIZONTAL AT 3 M								
NO.	FREQ. (MHz)	EMISSION LEVEL (dBuV/m)	LIMIT (dBuV/m)	MARGIN (dB)	ANTENNA HEIGHT (m)	TABLE ANGLE (Degree)	RAW VALUE (dBuV)	CORRECTION FACTOR (dB/m)
1	56.43	31.7 QP	40.0	-8.3	1.05 H	169	18.95	12.75
2	258.51	32.1 QP	46.0	-13.9	1.17 H	10	18.64	13.44
3	365.77	31.8 QP	46.0	-14.2	1.03 H	19	14.65	17.15
4	602.05	32.6 QP	46.0	-13.5	1.28 H	10	9.30	23.25
5	796.36	42.4 QP	46.0	-3.6	1.01 H	49	15.88	26.55
6	843.00	32.4 QP	46.0	-13.6	1.20 H	274	5.10	27.29
7	930.05	35.7 QP	46.0	-10.4	1.00 H	274	7.28	28.37
ANTENNA POLARITY & TEST DISTANCE: VERTICAL AT 3 M								
NO.	FREQ. (MHz)	EMISSION LEVEL (dBuV/m)	LIMIT (dBuV/m)	MARGIN (dB)	ANTENNA HEIGHT (m)	TABLE ANGLE (Degree)	RAW VALUE (dBuV)	CORRECTION FACTOR (dB/m)
1	37.77	24.5 QP	40.0	-15.5	1.05 V	295	11.62	12.90
2	148.14	27.2 QP	43.5	-16.4	1.12 V	268	12.89	14.26
3	168.35	26.9 QP	43.5	-16.6	1.04 V	187	13.07	13.86
4	365.77	29.6 QP	46.0	-16.4	1.23 V	259	12.43	17.15
5	597.39	29.7 QP	46.0	-16.3	1.27 V	244	6.51	23.17
6	741.96	29.2 QP	46.0	-16.8	1.32 V	358	3.55	25.64
7	771.49	30.5 QP	46.0	-15.5	1.25 V	34	4.33	26.15
8	900.51	34.1 QP	46.0	-11.9	1.01 V	304	6.09	28.05

- REMARKS:**
1. Emission level (dBuV/m) = Raw Value (dBuV) + Correction Factor (dB/m).
  2. Correction Factor (dB/m) = Antenna Factor (dB/m) + Cable Factor (dB).
  3. The other emission levels were very low against the limit.
  4. Margin value = Emission level – Limit value.



A D T

## 5.2 CONDUCTED EMISSION MEASUREMENT

### 5.2.1 LIMITS OF CONDUCTED EMISSION MEASUREMENT

FREQUENCY OF EMISSION (MHz)	CONDUCTED LIMIT (dB $\mu$ V)	
	Quasi-peak	Average
0.15 ~ 0.5	66 to 56	56 to 46
0.5 ~ 5	56	46
5 ~ 30	60	50

- NOTE:** 1. The lower limit shall apply at the transition frequencies.
2. The limit decreases in line with the logarithm of the frequency in the range of 0.15 to 0.50MHz.
3. All emanations from a class A/B digital device or system, including any network of conductors and apparatus connected thereto, shall not exceed the level of field strengths specified above.

### 5.2.2 TEST INSTRUMENTS

DESCRIPTION & MANUFACTURER	MODEL NO.	SERIAL NO.	CALIBRATED DATE	CALIBRATED UNTIL
ROHDE & SCHWARZ Test Receiver	ESCS 30	838251/021	Mar. 05, 2009	Mar. 04, 2010
ROHDE & SCHWARZ Artificial Mains Network (for EUT)	ESH3-Z5	100218	Nov. 24, 2008	Nov. 23, 2009
LISN With Adapter (for EUT)	AD10	C10Ada-001	Nov. 24, 2008	Nov. 23, 2009
ROHDE & SCHWARZ Artificial Mains Network (for peripherals)	ESH3-Z5	100219	Nov. 23, 2009	Nov. 22, 2010
Software	ADT_Cond_V7.3.7	NA	NA	NA
Software	ADT_ISN_V7.3.7	NA	NA	NA
RF cable (JYEBAO)	5D-FB	Cable-C10.01	Feb. 26, 2009	Feb. 25, 2010
SUHNER Terminator (For ROHDE & SCHWARZ LISN)	65BNC-5001	E1-010773	Feb. 27, 2009	Feb. 26, 2010

- NOTE:** 1. The calibration interval of the above test instruments is 12 months and the calibrations are traceable to NML/ROC and NIST/USA.
2. The test was performed in Shielded Room No. 10.
3. The VCCI Site Registration No. C-1852.





A D T

### **5.2.3 TEST PROCEDURES**

- a. The EUT was placed 0.4 meters from the conducting wall of the shielded room with EUT being connected to the power mains through a line impedance stabilization network (LISN). Other support units were connected to the power mains through another LISN. The two LISNs provide 50 ohm/ 50uH of coupling impedance for the measuring instrument.
- b. Both lines of the power mains connected to the EUT were checked for maximum conducted interference.
- c. The frequency range from 150kHz to 30MHz was searched. Emission levels under (Limit - 20dB) was not recorded.

### **5.2.4 DEVIATION FROM TEST STANDARD**

No deviation

## 5.2.5 TEST SETUP

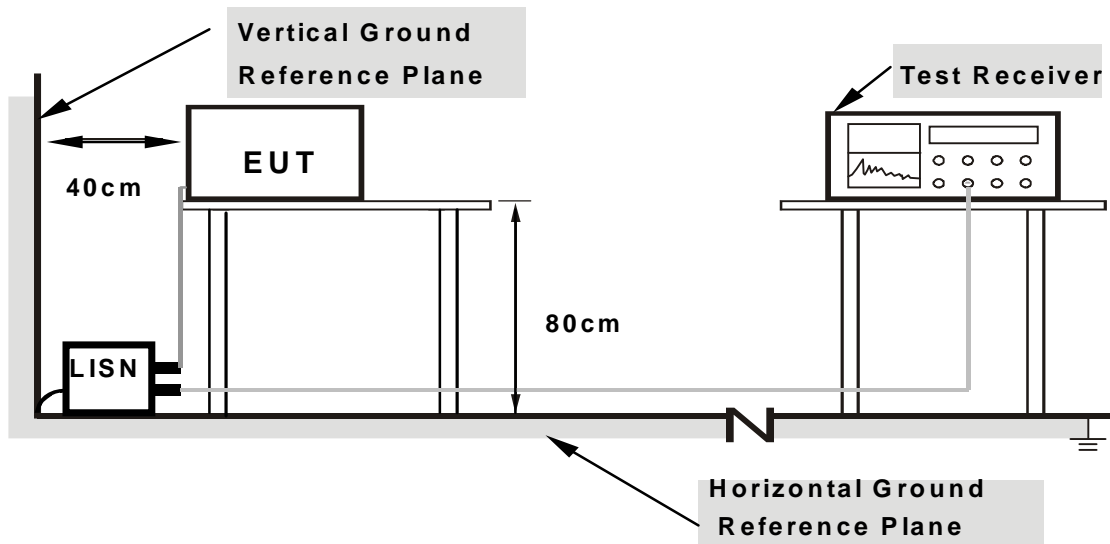

- Note:**
1. Support units were connected to second LISN.
  2. Both of LISNs (AMN) are 80 cm from EUT and at least 80 cm from other units and other metal planes

For the actual test configuration, please refer to the attached file (Test Setup Photo).

## 5.2.6 EUT OPERATING CONDITIONS

Same as 4.1.6

### 5.2.7 TEST RESULTS

CONDUCTED WORST-CASE DATA : 802.11n (20MHz)

CHANNEL	Channel 165	PHASE	Line 1
TEST MODE	A	6dB BANDWIDTH	9kHz

No	Freq. [MHz]	Corr. Factor (dB)	Reading Value		Emission Level		Limit		Margin	
			[dB (uV)]		[dB (uV)]		[dB (uV)]		(dB)	
			Q.P.	AV.	Q.P.	AV.	Q.P.	AV.	Q.P.	AV.
1	0.187	0.13	48.46	-	48.59	-	64.18	54.18	-15.60	-
2	0.275	0.17	37.14	-	37.31	-	60.98	50.98	-23.67	-
3	0.652	0.25	37.74	-	37.99	-	56.00	46.00	-18.01	-
4	1.611	0.33	30.79	-	31.12	-	56.00	46.00	-24.88	-
5	3.962	0.52	31.30	-	31.82	-	56.00	46.00	-24.18	-
6	16.531	1.33	36.57	-	37.90	-	60.00	50.00	-22.10	-

- REMARKS:**
1. Q.P. and AV. are abbreviations of quasi-peak and average individually.
  2. "-": The Quasi-peak reading value also meets average limit and measurement with the average detector is unnecessary.
  3. The emission levels of other frequencies were very low against the limit.
  4. Margin value = Emission level - Limit value
  5. Correction factor = Insertion loss + Cable loss
  6. Emission Level = Correction Factor + Reading Value.

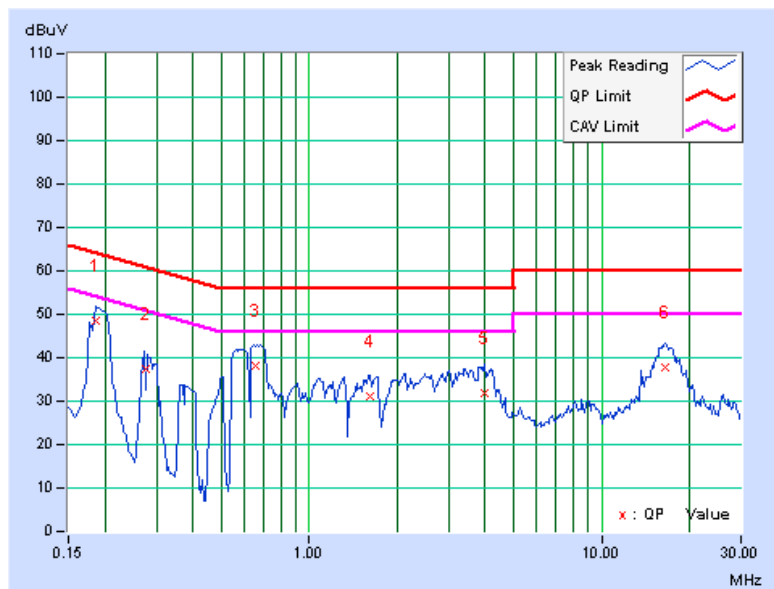



A D T

<b>CHANNEL</b>	Channel 165	<b>PHASE</b>	Line 2
<b>TEST MODE</b>	A	<b>6dB BANDWIDTH</b>	9kHz

No	Freq. [MHz]	Corr. Factor (dB)	Reading Value		Emission Level		Limit		Margin	
			[dB (uV)]		[dB (uV)]		[dB (uV)]		(dB)	
			Q.P.	AV.	Q.P.	AV.	Q.P.	AV.	Q.P.	AV.
1	0.189	0.13	45.77	-	45.90	-	64.07	54.07	-18.17	-
2	0.287	0.17	36.66	-	36.83	-	60.62	50.62	-23.79	-
3	0.707	0.30	41.89	-	42.19	-	56.00	46.00	-13.81	-
4	1.097	0.38	36.93	-	37.31	-	56.00	46.00	-18.69	-
5	2.505	0.49	34.02	-	34.51	-	56.00	46.00	-21.49	-
6	16.551	1.17	35.76	-	36.93	-	60.00	50.00	-23.07	-

- REMARKS:**
1. Q.P. and AV. are abbreviations of quasi-peak and average individually.
  2. "-": The Quasi-peak reading value also meets average limit and measurement with the average detector is unnecessary.
  3. The emission levels of other frequencies were very low against the limit.
  4. Margin value = Emission level - Limit value
  5. Correction factor = Insertion loss + Cable loss
  6. Emission Level = Correction Factor + Reading Value.

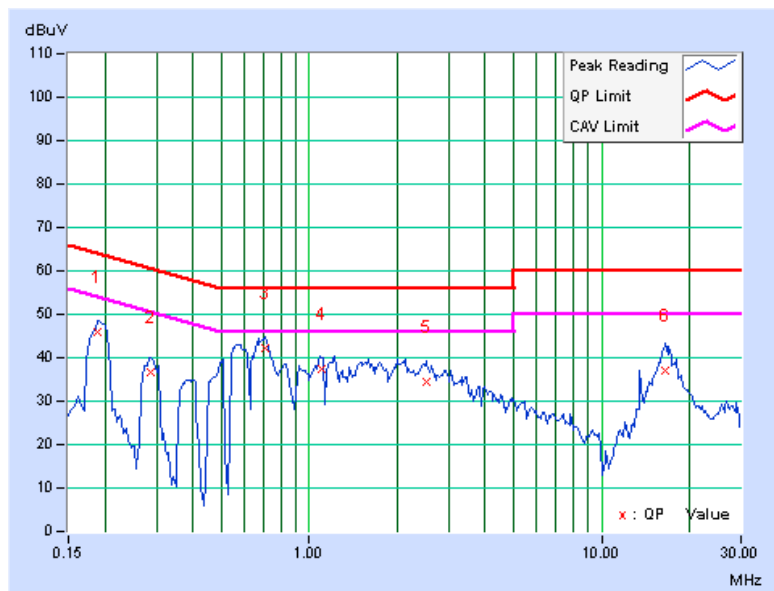



A D T

## 5.3 6dB BANDWIDTH MEASUREMENT

### 5.3.1 LIMITS OF 6dB BANDWIDTH MEASUREMENT

The minimum of 6dB Bandwidth Measurement is 0.5MHz.

### 5.3.2 TEST INSTRUMENTS

DESCRIPTION & MANUFACTURER	MODEL NO.	SERIAL NO.	DATE OF CALIBRATION	DUE DATE OF CALIBRATION
R&S SPECTRUM ANALYZER	FSP 40	100036	Apr. 03, 2009	Apr. 02, 2010

**NOTE:** The calibration interval of the above test instruments is 12 months and the calibrations are traceable to NML/ROC and NIST/USA.

### 5.3.3 TEST PROCEDURE

The transmitter output was connected to the spectrum analyzer through an attenuator. The bandwidth of the fundamental frequency was measured by spectrum analyzer with 100kHz RBW and 300kHz VBW. The 6dB bandwidth is defined as the total spectrum the power of which is higher than peak power minus 6dB.

### **5.3.4 DEVIATION FROM TEST STANDARD**

No deviation

### **5.3.5 TEST SETUP**

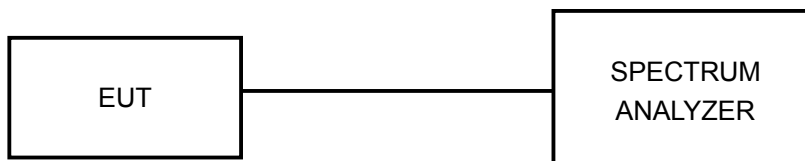

### **5.3.6 EUT OPERATING CONDITIONS**

The software provided by client to enable the EUT under transmission condition continuously at lowest, middle and highest channel frequencies individually.



A D T

### 5.3.7 TEST RESULTS

#### 802.11a

CHANNEL	CHANNEL FREQUENCY (MHz)	6dB BANDWIDTH (MHz)	MINIMUM LIMIT (MHz)	PASS / FAIL
149	5745	16.42	0.5	PASS
157	5785	16.39	0.5	PASS
165	5825	16.46	0.5	PASS

#### CH 165

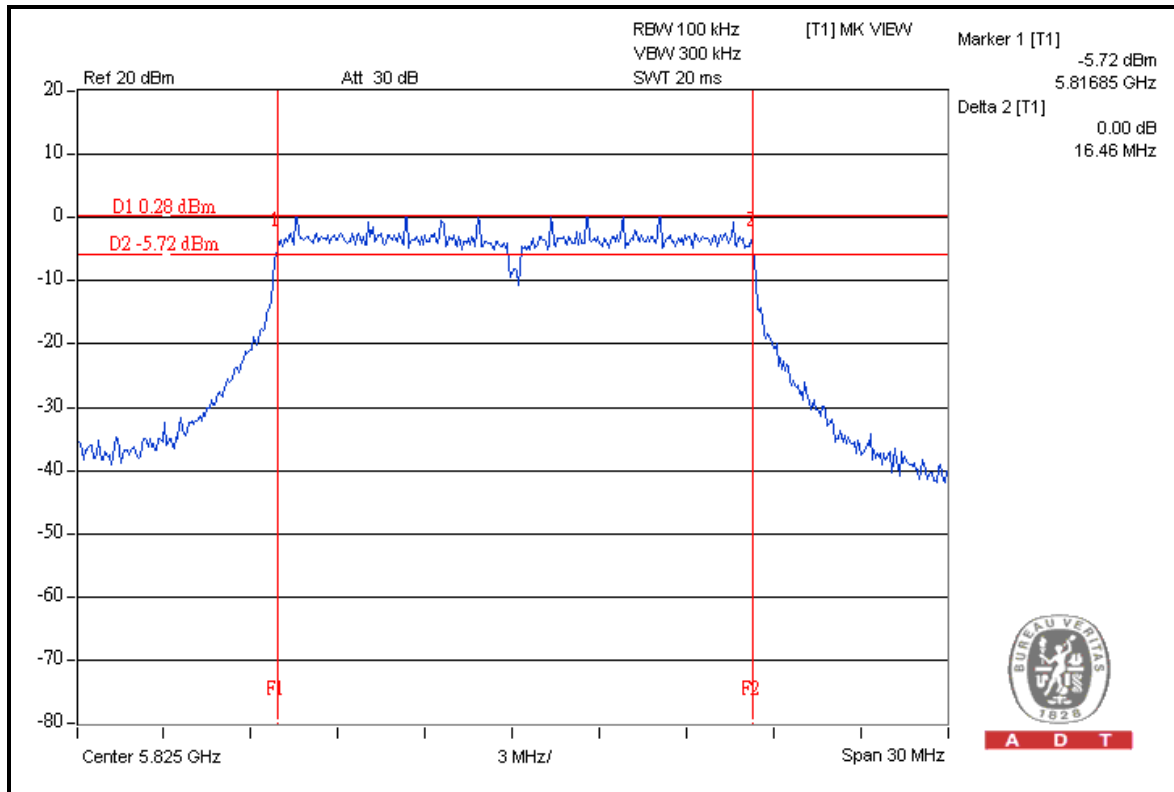



A D T

### 802.11n (20MHz)

CHANNEL	CHANNEL FREQUENCY (MHz)	6dB BANDWIDTH (MHz)	MINIMUM LIMIT (MHz)	PASS / FAIL
149	5745	17.56	0.5	PASS
157	5785	17.38	0.5	PASS
165	5825	17.58	0.5	PASS

### CH 165

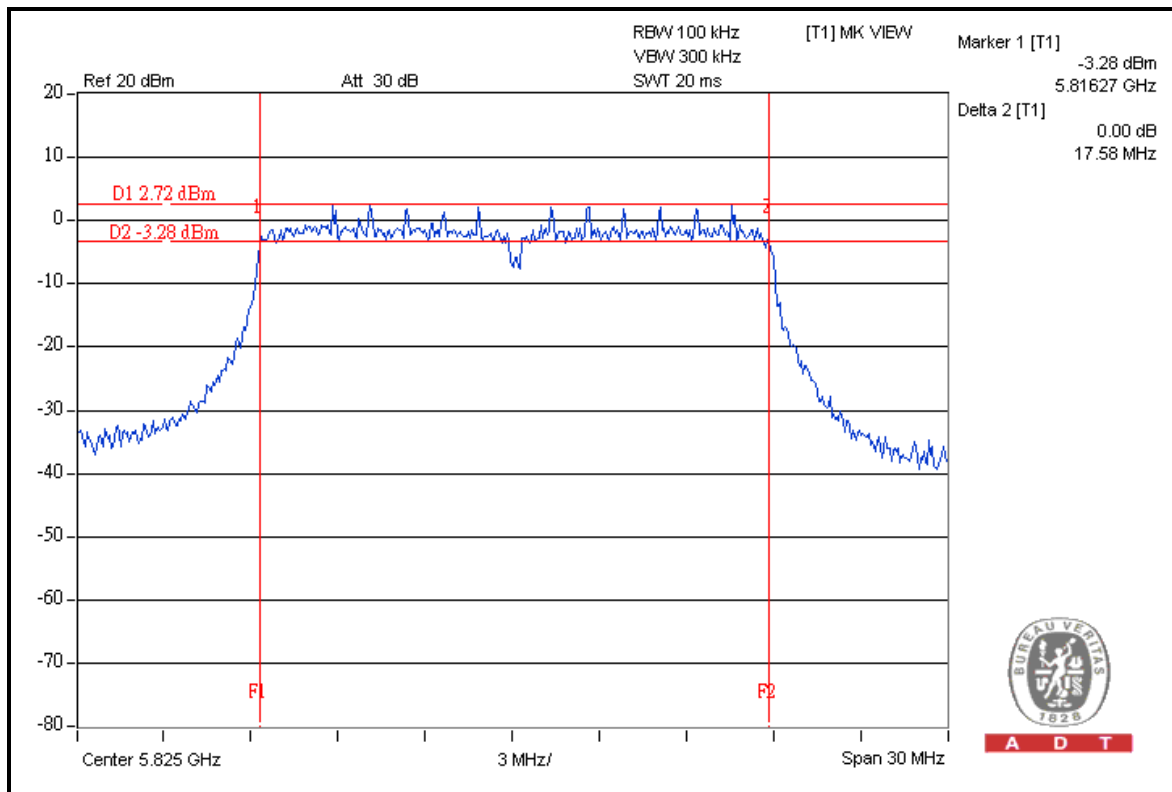





A D T

### 802.11n (40MHz)

CHANNEL	CHANNEL FREQUENCY (MHz)	6dB BANDWIDTH (MHz)	MINIMUM LIMIT (MHz)	PASS / FAIL
151	5755	35.73	0.5	PASS
159	5795	35.30	0.5	PASS

### CH 151

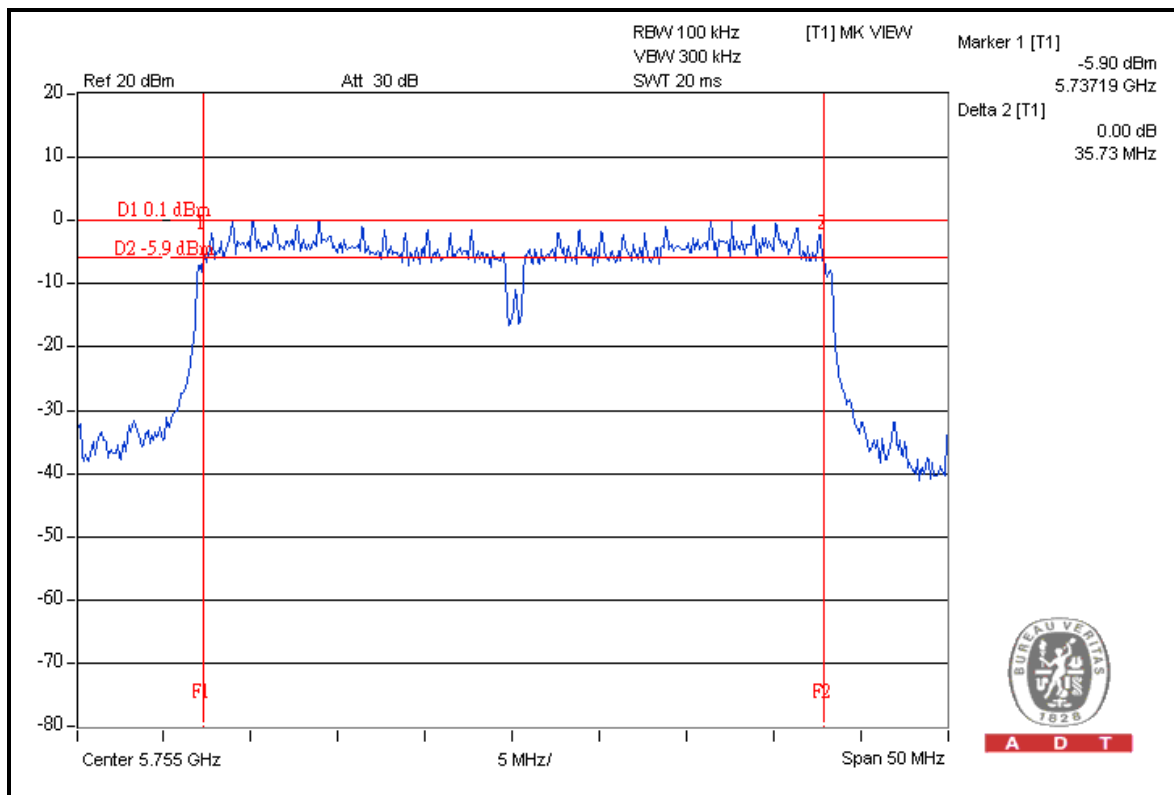



A D T

## 5.4 MAXIMUM OUTPUT POWER

### 5.4.1 LIMITS OF MAXIMUM OUTPUT POWER MEASUREMENT

The Maximum Peak Output Power Measurement is 30dBm.

### 5.4.2 INSTRUMENTS

DESCRIPTION & MANUFACTURER	MODEL NO.	SERIAL NO.	DATE OF CALIBRATION	DUE DATE OF CALIBRATION
Peak Power meter & Anritsu	ML2495A	0842014	Apr. 25, 2009	Apr. 24, 2010
Pulse Power Sensor & Anritsu	MA2411B	0738404	Apr. 25, 2009	Apr. 24, 2010

**Note:**

1. The calibration interval of the above test instruments is 12 months and the calibrations are traceable to NML/ROC and NIST/USA.
2. Measurement Bandwidth of ML2495A is 65MHz greater than 6dB bandwidth of emission.

### 5.4.3 TEST PROCEDURES

A power sensor was used on the output port of the EUT. A power meter was used to read the response of the power sensor. Record the power level.

#### 5.4.4 DEVIATION FROM TEST STANDARD

No deviation

#### 5.4.5 TEST SETUP

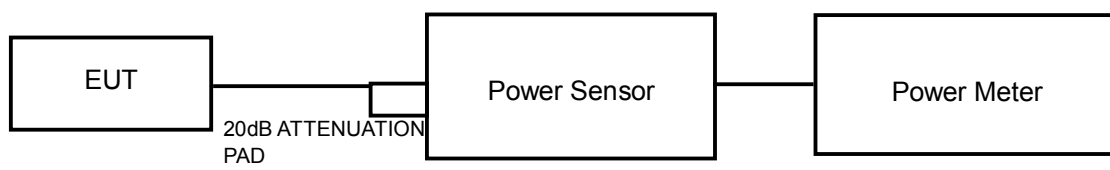

#### 5.4.6 EUT OPERATING CONDITIONS

Same as Item 5.3.6



## 5.4.7 TEST RESULTS

### 802.11a

CHANNEL	CHANNEL FREQUENCY (MHz)	POWER OUTPUT (dBm)	POWER OUTPUT (mW)	POWER LIMIT (dBm)	PASS / FAIL
149	5745	20.4	109.6	30	PASS
157	5785	20.0	100.0	30	PASS
165	5825	21.1	128.8	30	PASS

### 802.11n (20MHz)

CHANNEL	CHANNEL FREQUENCY (MHz)	POWER OUTPUT (dBm)	POWER OUTPUT (mW)	POWER LIMIT (dBm)	PASS / FAIL
149	5745	20.1	102.3	30	PASS
157	5785	20.6	114.8	30	PASS
165	5825	22.0	158.5	30	PASS

### 802.11n (40MHz)

CHANNEL	CHANNEL FREQUENCY (MHz)	POWER OUTPUT (dBm)	POWER OUTPUT (mW)	POWER LIMIT (dBm)	PASS / FAIL
151	5755	21.8	151.4	30	PASS
159	5795	22.9	195.0	30	PASS



A D T

## 5.5 POWER SPECTRAL DENSITY MEASUREMENT

### 5.5.1 LIMITS OF POWER SPECTRAL DENSITY MEASUREMENT

The Maximum of Power Spectral Density Measurement is 8dBm.

### 5.5.2 TEST INSTRUMENTS

DESCRIPTION & MANUFACTURER	MODEL NO.	SERIAL NO.	DATE OF CALIBRATION	DUE DATE OF CALIBRATION
R&S SPECTRUM ANALYZER	FSP 40	100036	Apr. 03, 2009	Apr. 02, 2010

**NOTE:** The calibration interval of the above test instruments is 12 months and the calibrations are traceable to NML/ROC and NIST/USA.

### 5.5.3 TEST PROCEDURE

The transmitter output was connected to the spectrum analyzer through an attenuator, the bandwidth of the fundamental frequency was measured with the spectrum analyzer using 3kHz RBW and 30kHz VBW, set sweep time = span/3kHz. The power spectral density was measured and recorded.

The sweep time is allowed to be longer than span/3kHz for a full response of the mixer in the spectrum analyzer.



A D T

#### 5.5.4 DEVIATION FROM TEST STANDARD

No deviation

#### 5.5.5 TEST SETUP

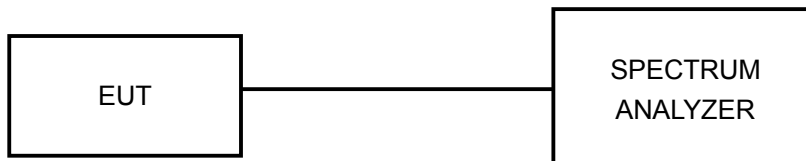

#### 5.5.6 EUT OPERATING CONDITION

Same as Item 5.3.6



A D T

## 5.5.7 TEST RESULTS

### 802.11a

CHANNEL	CHANNEL FREQUENCY (MHz)	RF POWER LEVEL IN 3kHz BW (dBm)	MAXIMUM LIMIT (dBm)	PASS / FAIL
149	5745	-17.1	8	PASS
157	5785	-16.6	8	PASS
165	5825	-13.4	8	PASS

### CH 165

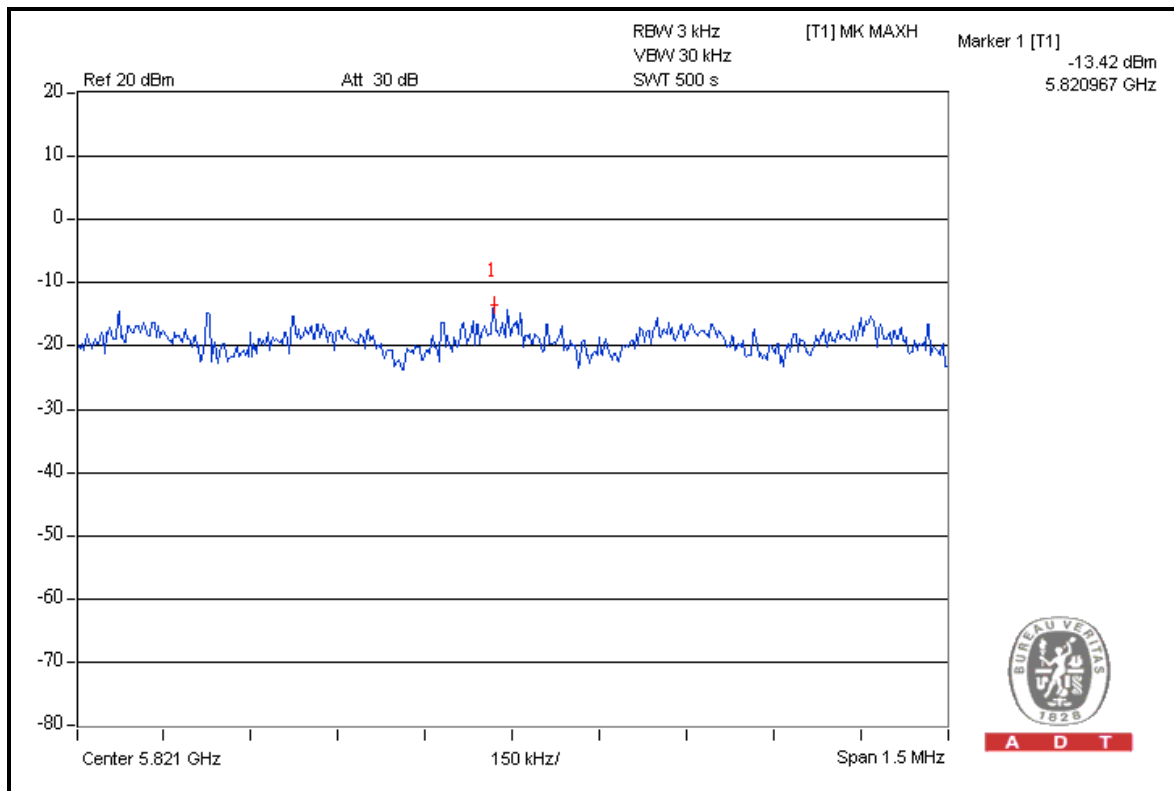



A D T

### 802.11n (20MHz)

CHANNEL	CHANNEL FREQUENCY (MHz)	RF POWER LEVEL IN 3kHz BW (dBm)	MAXIMUM LIMIT (dBm)	PASS / FAIL
149	5745	-14.2	8	PASS
157	5785	-15.1	8	PASS
165	5825	-11.4	8	PASS

### CH 165

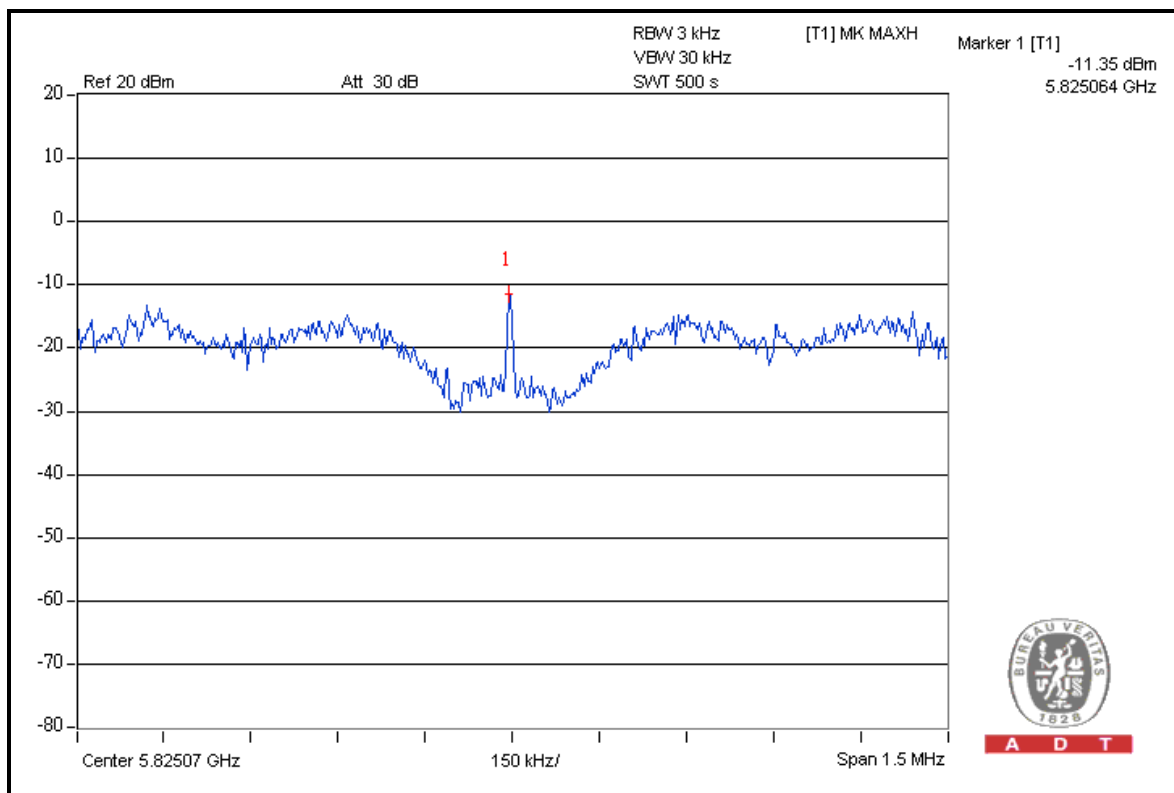





A D T

### 802.11n (40MHz)

CHANNEL	CHANNEL FREQUENCY (MHz)	RF POWER LEVEL IN 3kHz BW (dBm)	MAXIMUM LIMIT (dBm)	PASS / FAIL
151	5755	-14.0	8	PASS
159	5795	-10.6	8	PASS

### CH 159

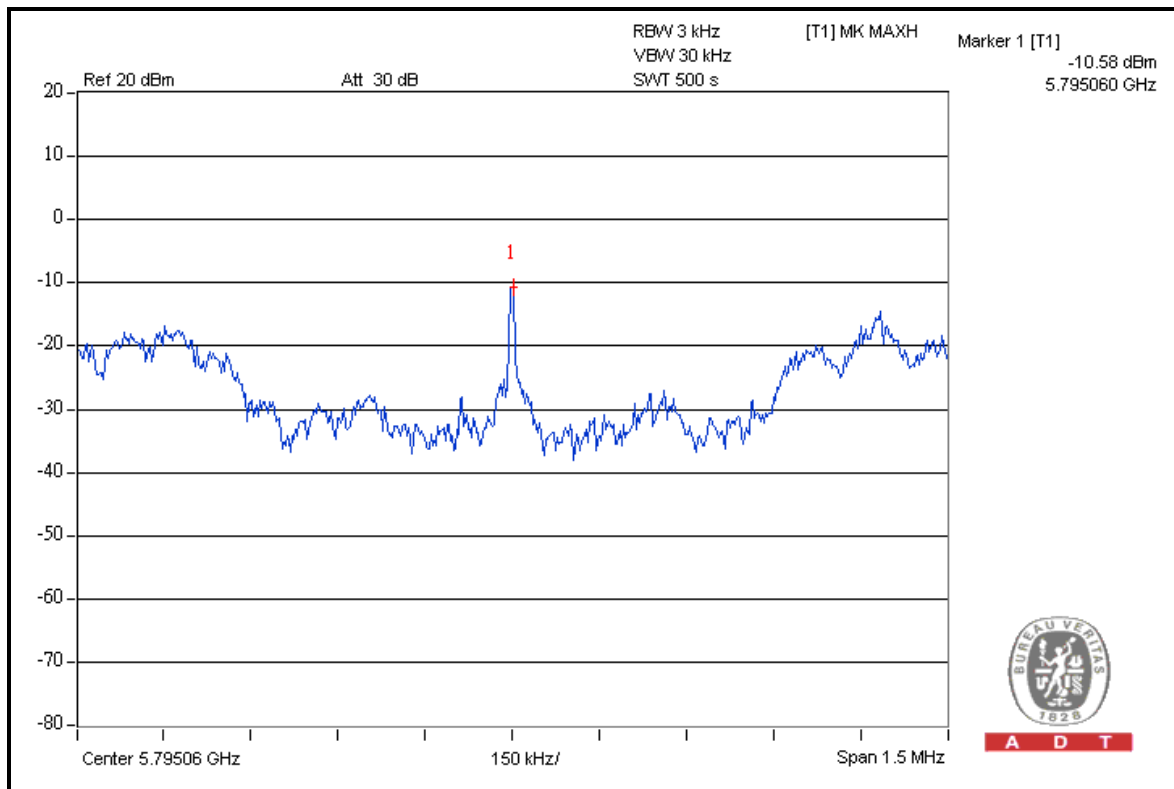



A D T

## 5.6 BAND EDGES MEASUREMENT

### 5.6.1 LIMITS OF BAND EDGES MEASUREMENT

Below -20dB of the highest emission level of operating band (in 100kHz Resolution Bandwidth).

### 5.6.2 TEST INSTRUMENTS

DESCRIPTION & MANUFACTURER	MODEL NO.	SERIAL NO.	DATE OF CALIBRATION	DUE DATE OF CALIBRATION
<b>FOR CONDUCTED MEASUREMENT:</b>				
R&S SPECTRUM ANALYZER	FSP 40	100036	Apr. 03, 2009	Apr. 02, 2010
<b>FOR RADIATED MEASUREMENT:</b>				
HP Preamplifier	8447D	2432A03504	May 04, 2009	May 03, 2010
HP Preamplifier	8449B	3008A01924	Aug. 31, 2009	Aug. 30, 2010
HP Preamplifier	8449B	3008A01292	Aug. 10, 2009	Aug. 09, 2010
ROHDE & SCHWARZ TEST RECEIVER	ESU26	100005	Jun. 06, 2009	Jun. 05, 2010
Schwarzbeck Antenna	VULB 9168	137	Apr. 29, 2009	Apr. 28, 2010
Schwarzbeck Antenna	VHBA 9123	480	Apr. 21, 2009	Apr. 20, 2010
EMCO Horn Antenna	3115	6714	Oct. 26, 2009	Oct. 25, 2010
EMCO Horn Antenna	3115	9312-4192	Apr. 17, 2009	Apr. 16, 2010
ADT. Turn Table	TT100	0306	NA	NA
ADT. Tower	AT100	0306	NA	NA
Software	ADT_Radiated_V7.6.15.9.2	NA	NA	NA
SUHNER RF cable	SF104-26.5	CABLE-CH6-17m-01	Aug. 20, 2009	Aug. 19, 2010
ROHDE & SCHWARZ Spectrum Analyzer	FSP 40	100036	Apr. 03, 2009	Apr. 02, 2010

**NOTE:** The calibration interval of the above test instruments is 12 months and the calibrations are traceable to NML/ROC and NIST/USA.



A D T

### 5.6.3 TEST PROCEDURE

#### FOR CONDUCTED MEASUREMENT:

The transmitter output was connected to the spectrum analyzer via a low loss cable. Set both RBW and VBW of spectrum analyzer to 100kHz and 300kHz with suitable frequency span including 100MHz bandwidth from band edge. The band edges was measured and recorded.

#### FOR RADIATED MEASUREMENT:

- a. The EUT was placed on the top of a rotating table 0.8 meters above the ground at a 3 meter semi-anechoic chamber. The table was rotated 360 degrees to determine the position of the highest radiation.
- b. The EUT was set 3 meters away from the interference-receiving antenna, which was mounted on the top of a variable-height antenna tower.
- c. The antenna is a broadband antenna, and its height is varied from one meter to four meters above the ground to determine the maximum value of the field strength. Both horizontal and vertical polarizations of the antenna are set to make the measurement.
- d. For each suspected emission, the EUT was arranged to its worst case and then the antenna was tuned to heights from 1 meter to 4 meters and the rotatable table was turned from 0 degrees to 360 degrees to find the maximum reading.
- e. Set both RBW and VBW of spectrum analyzer to 100kHz and 300kHz with suitable frequency span including 100MHz bandwidth from band edge. The band edges was measured and recorded.

**NOTE:** The resolution bandwidth of test receiver/spectrum analyzer is 1MHz and the video bandwidth is 10Hz for Average detection (AV) at frequency above 1GHz.



A D T

#### **5.6.4 DEVIATION FROM TEST STANDARD**

No deviation

#### **5.6.5 EUT OPERATING CONDITION**

Same as Item 5.3.6

#### **5.6.6 TEST RESULTS**

The spectrum plots are attached on the following pages. D1 line indicates the highest level, D2 line indicates the 20dB offset below D1. It shows compliance with the requirement in part 15.247(d).



A D T

### 802.11a OFDM MODULATION

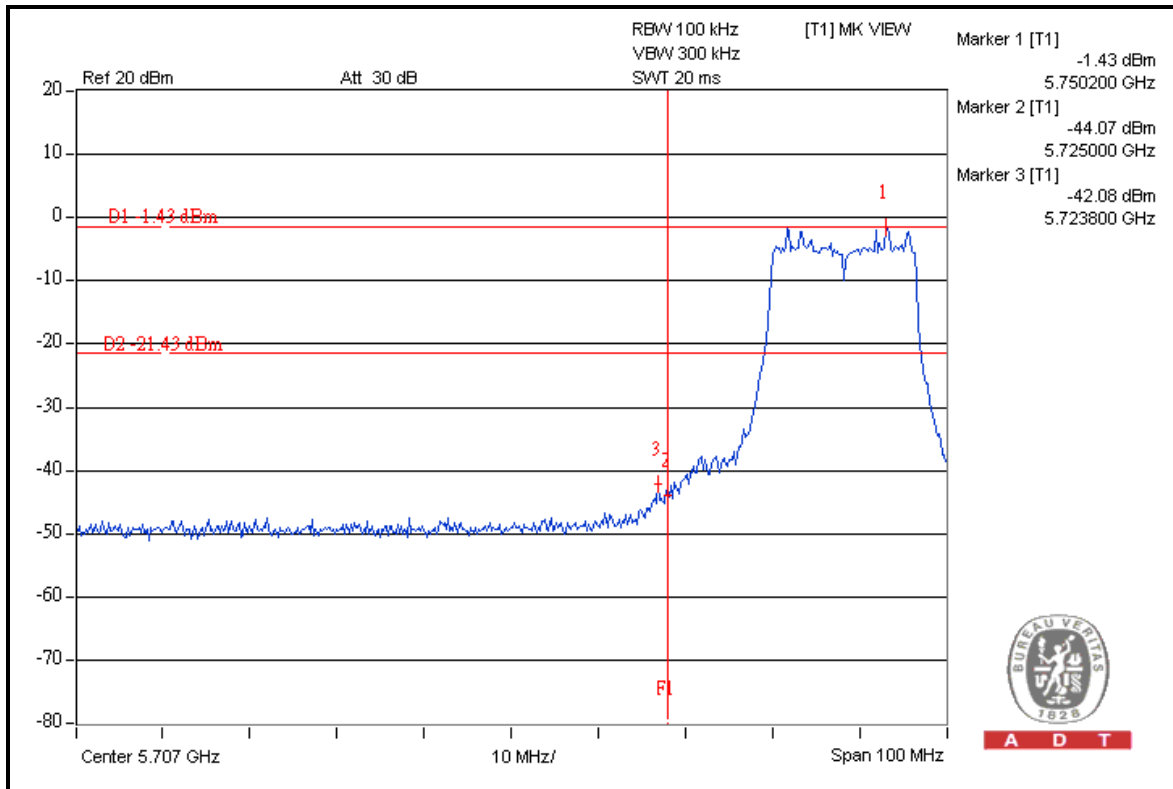

A D T

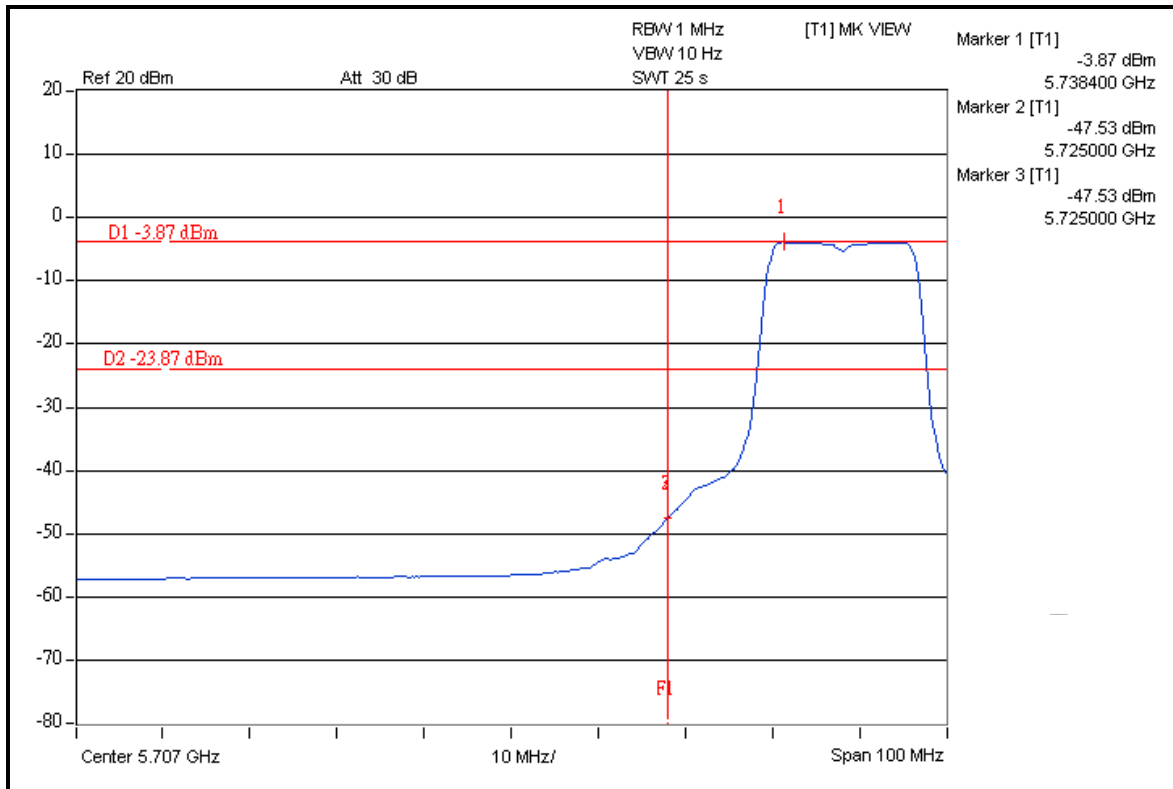



A D T

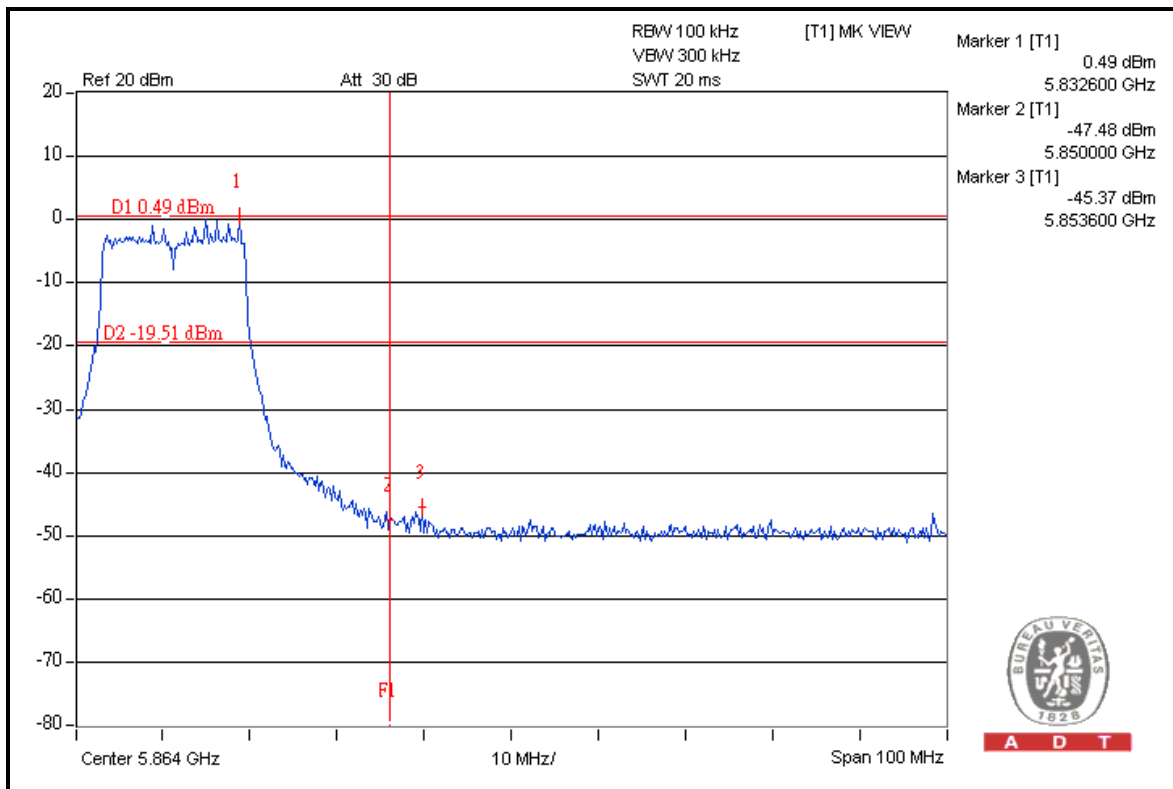
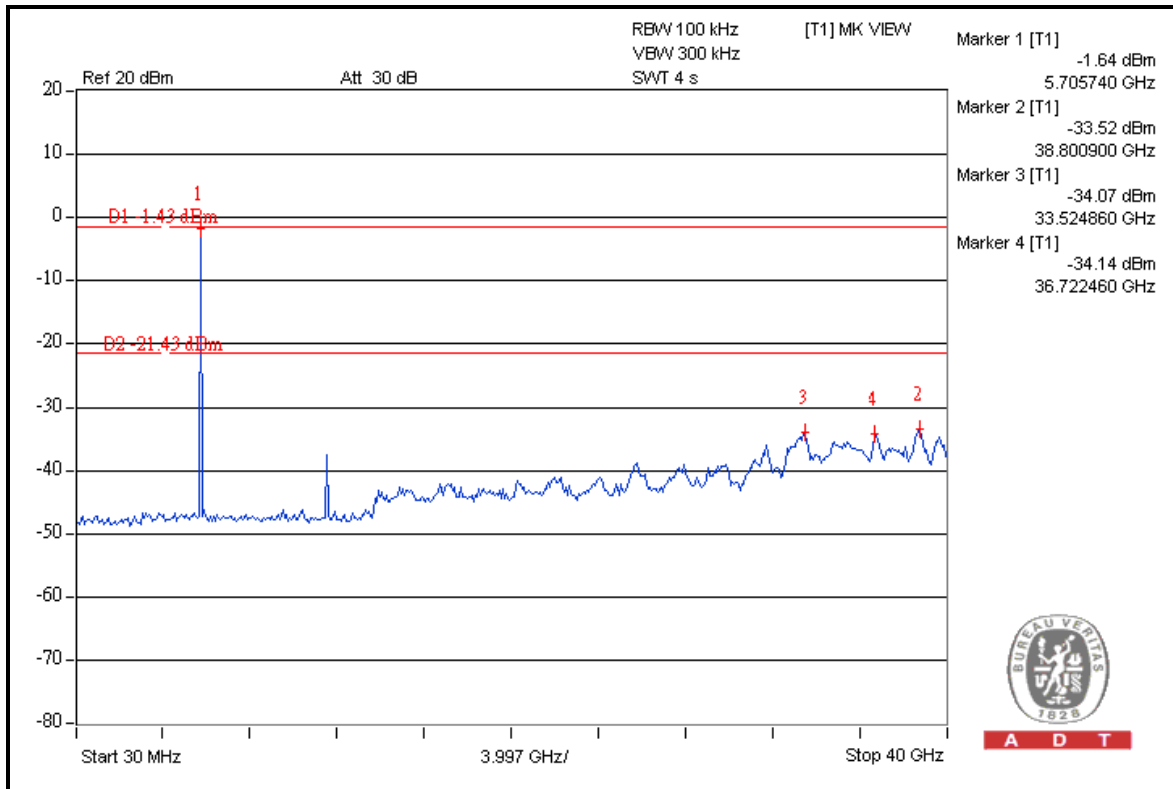



A D T

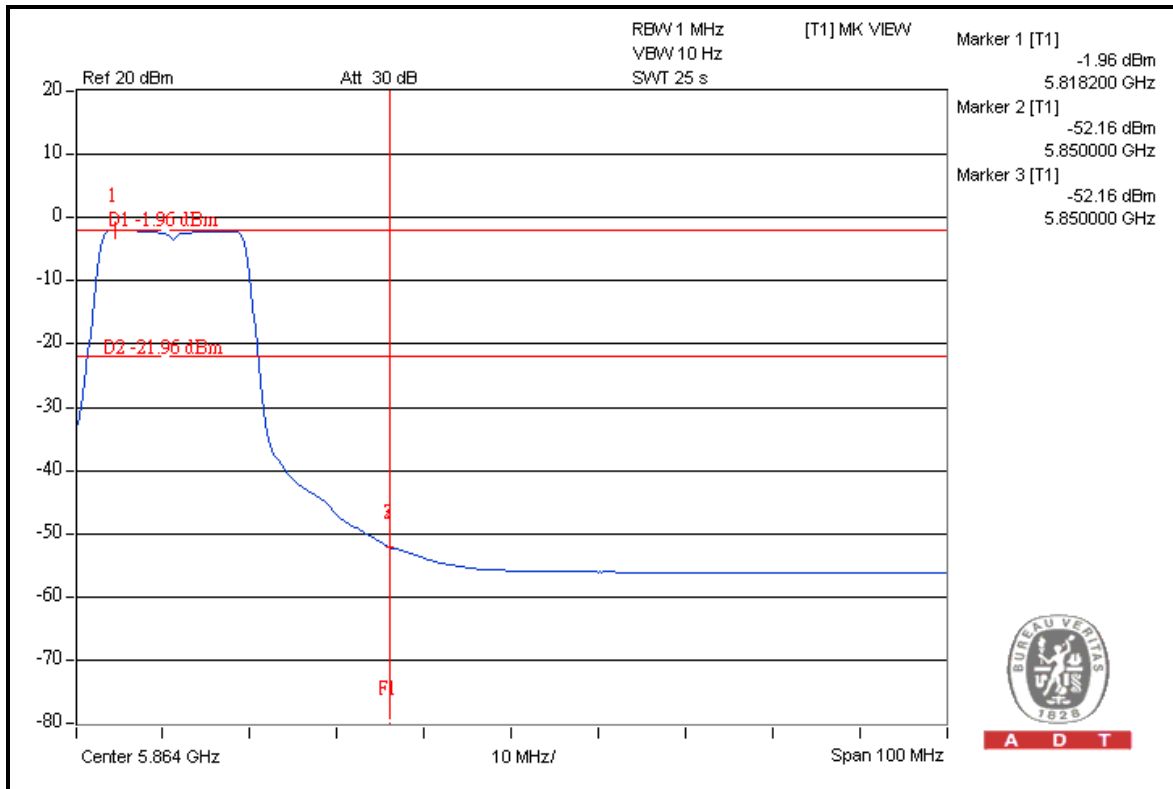

A D T

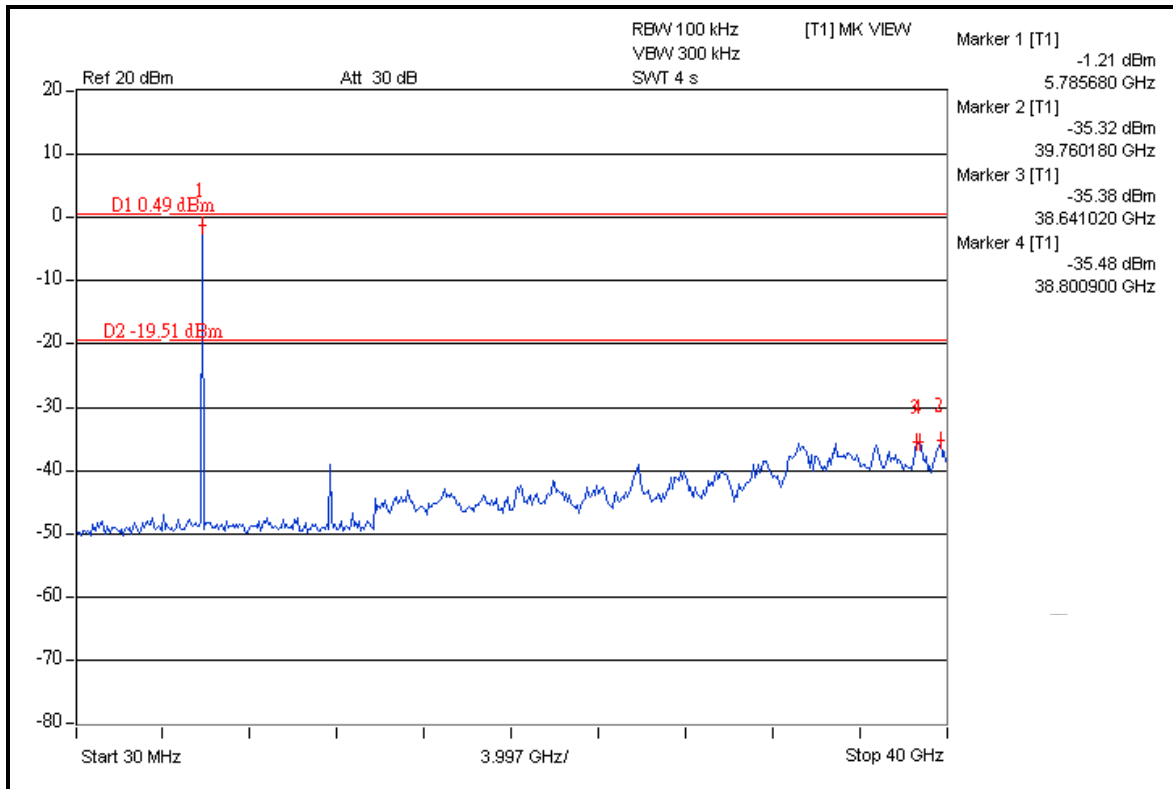



A D T

### 802.11n (20MHz)

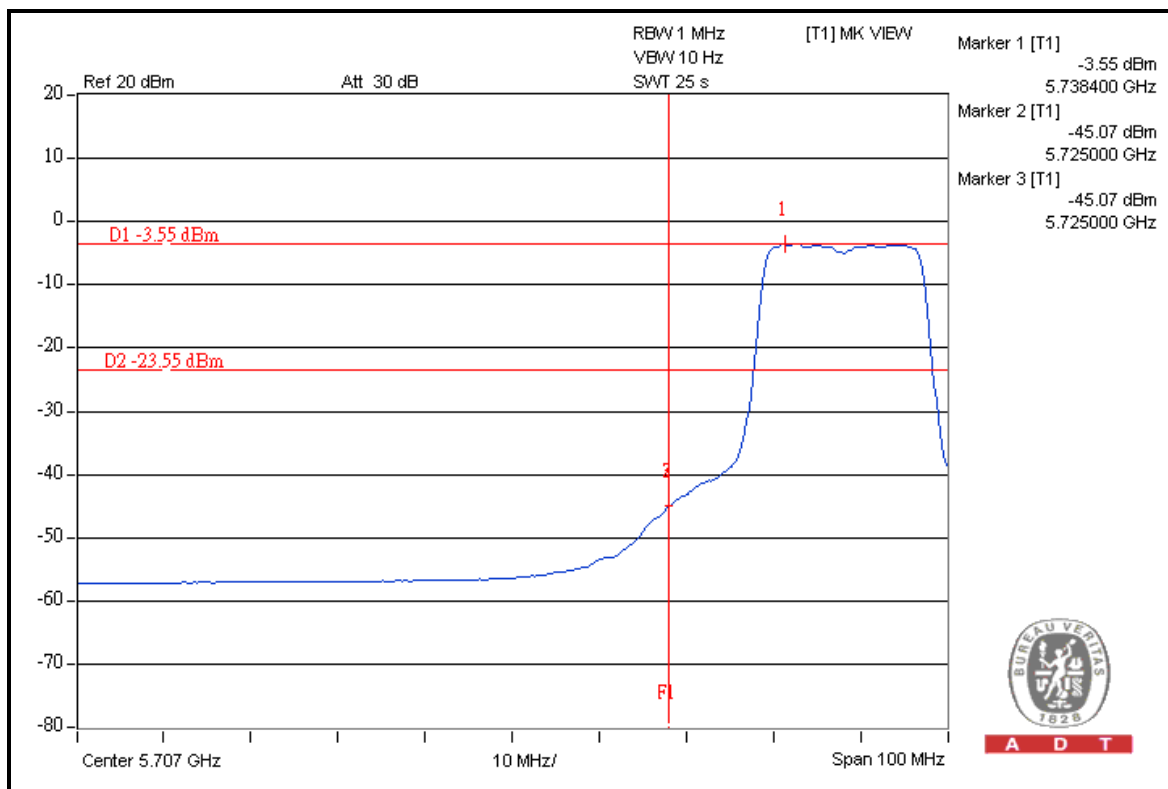
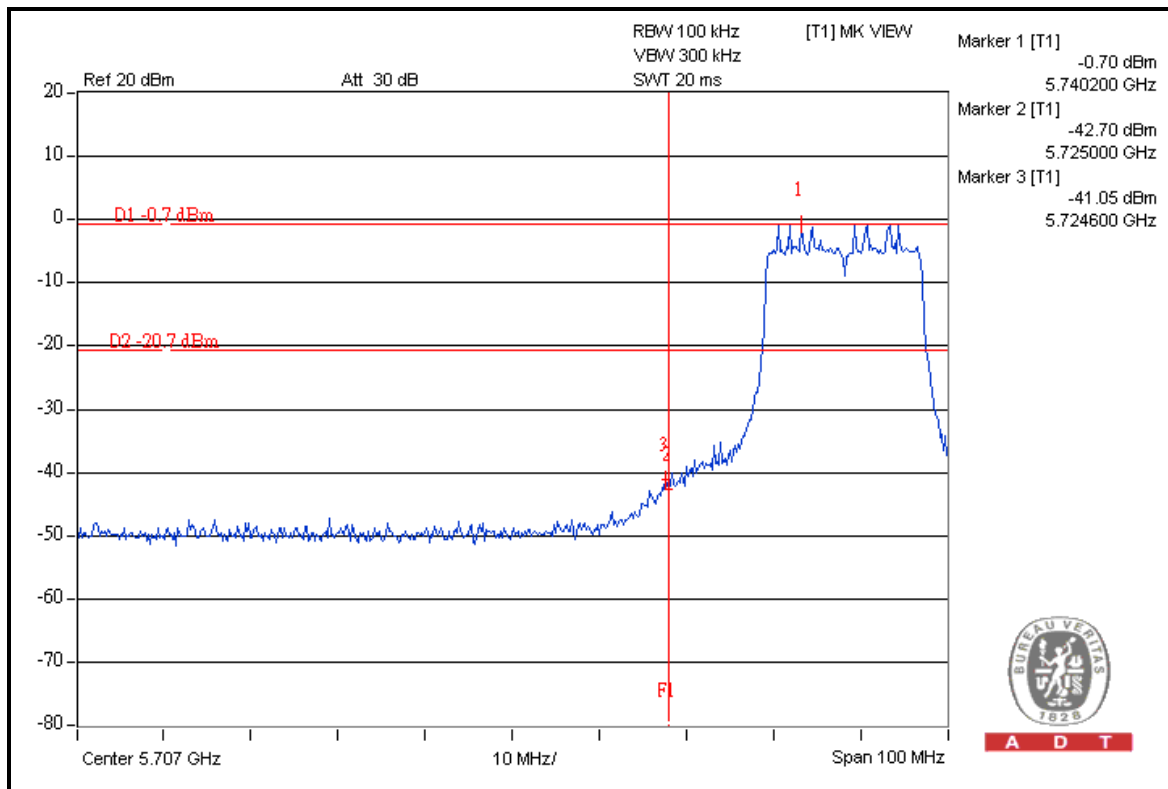





A D T

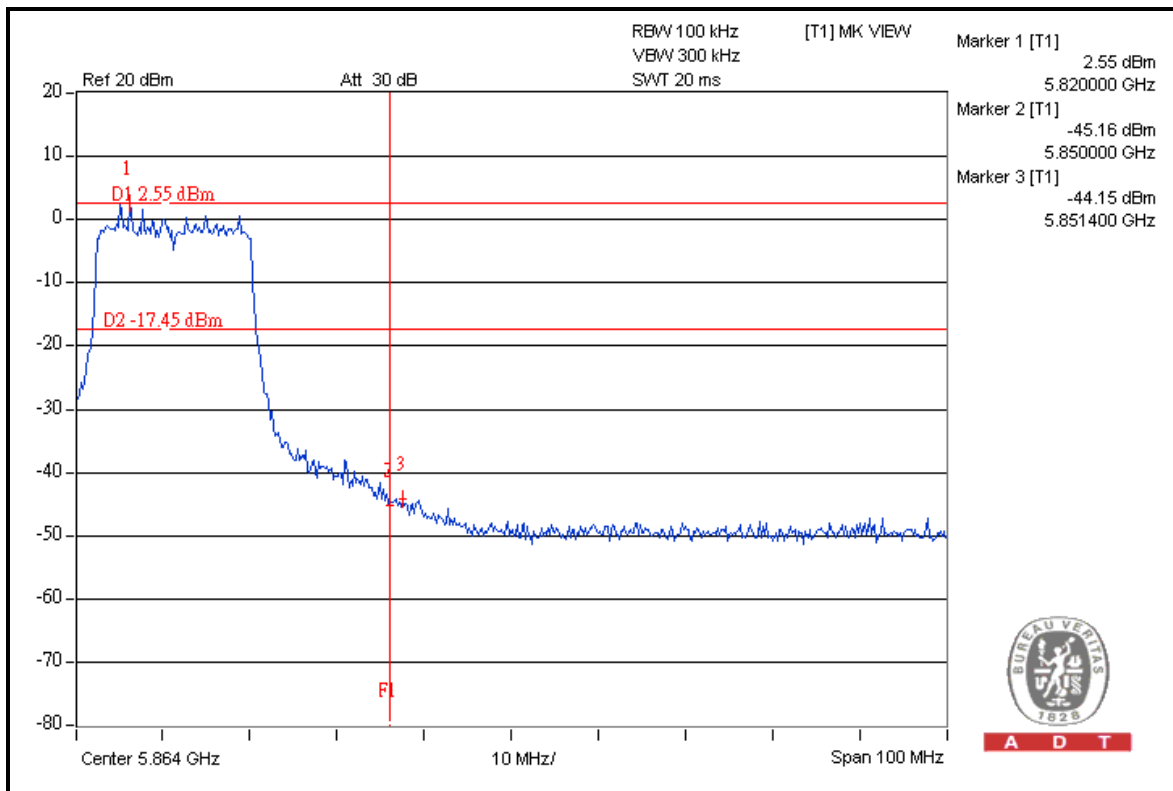
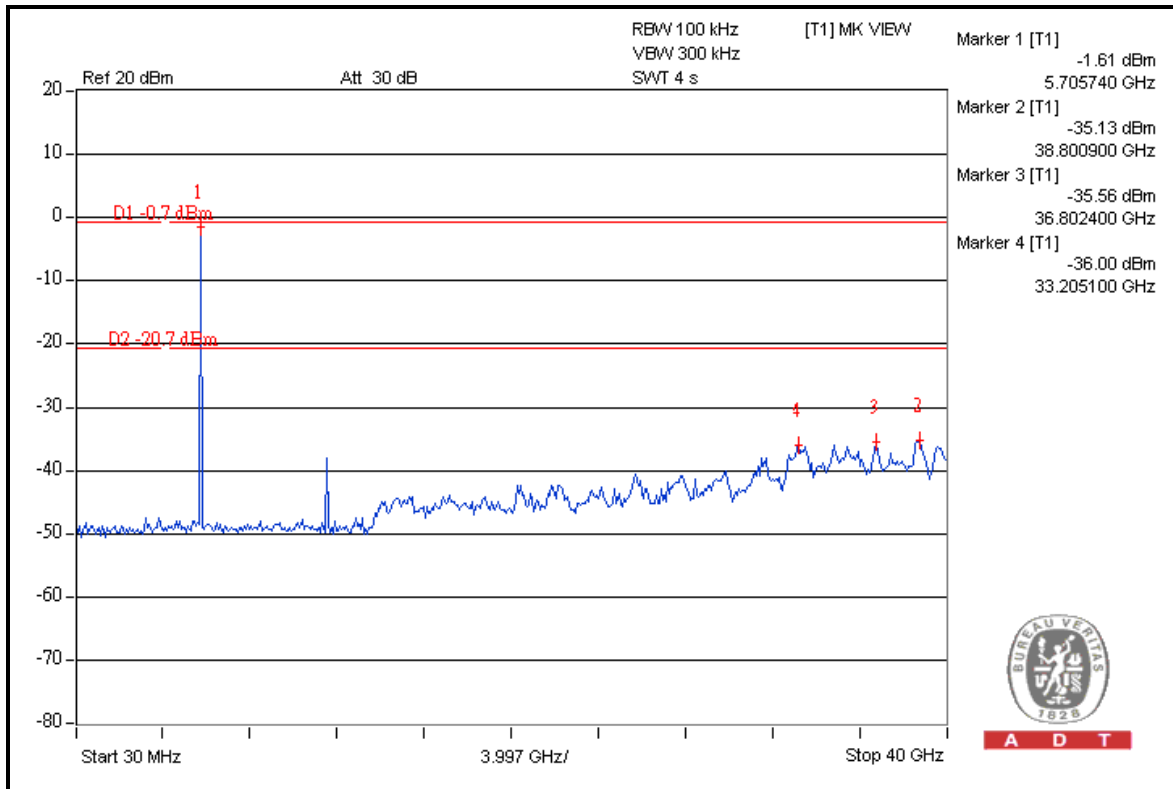



A D T

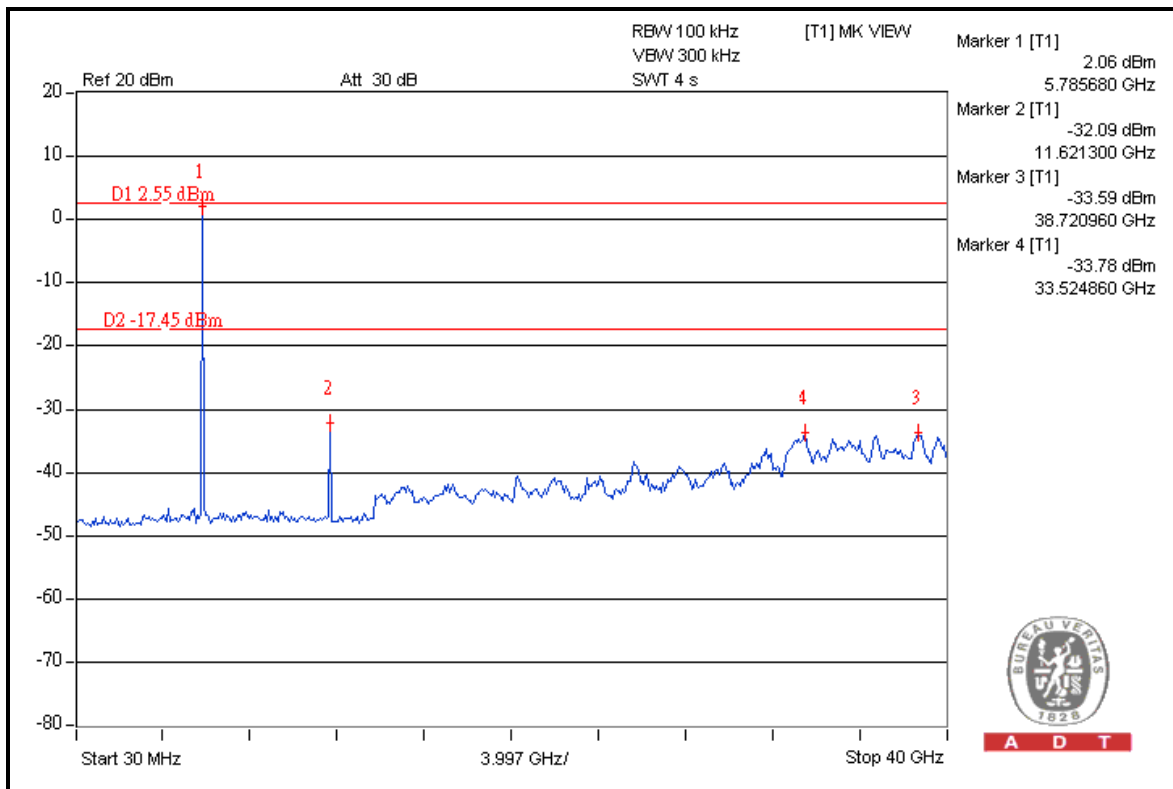
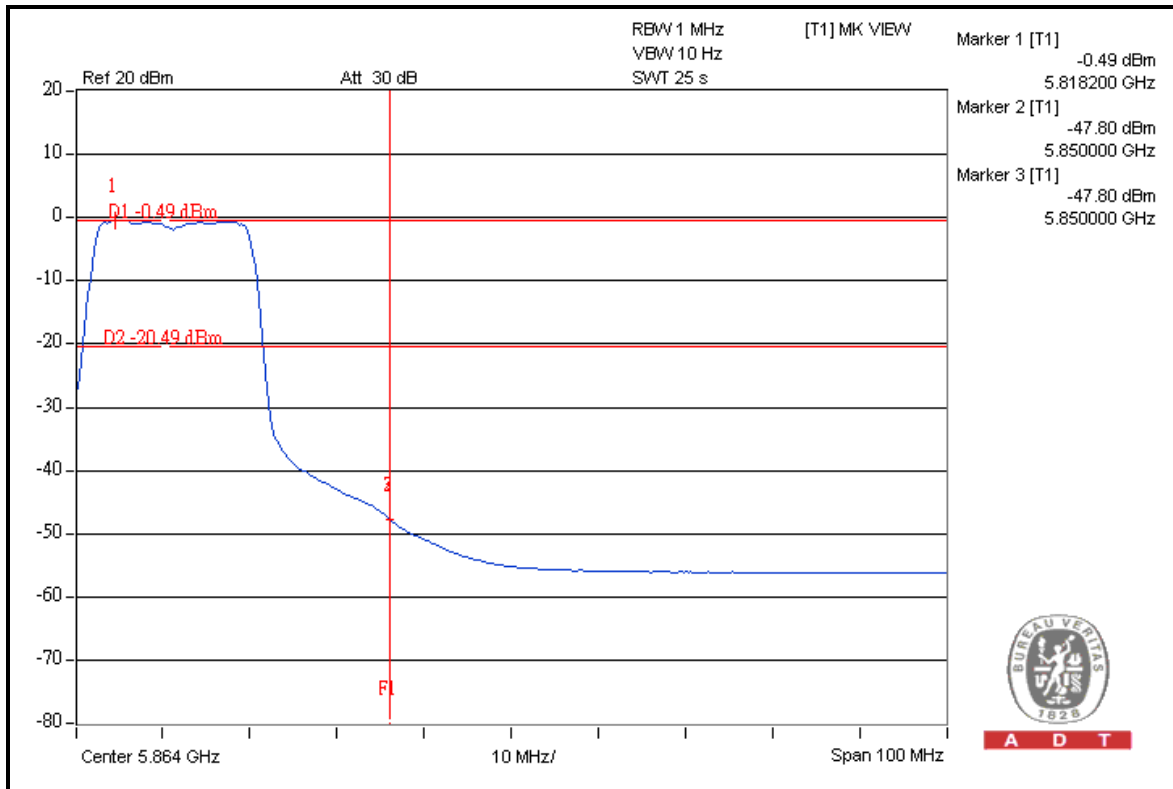



A D T

### 802.11n (40MHz)

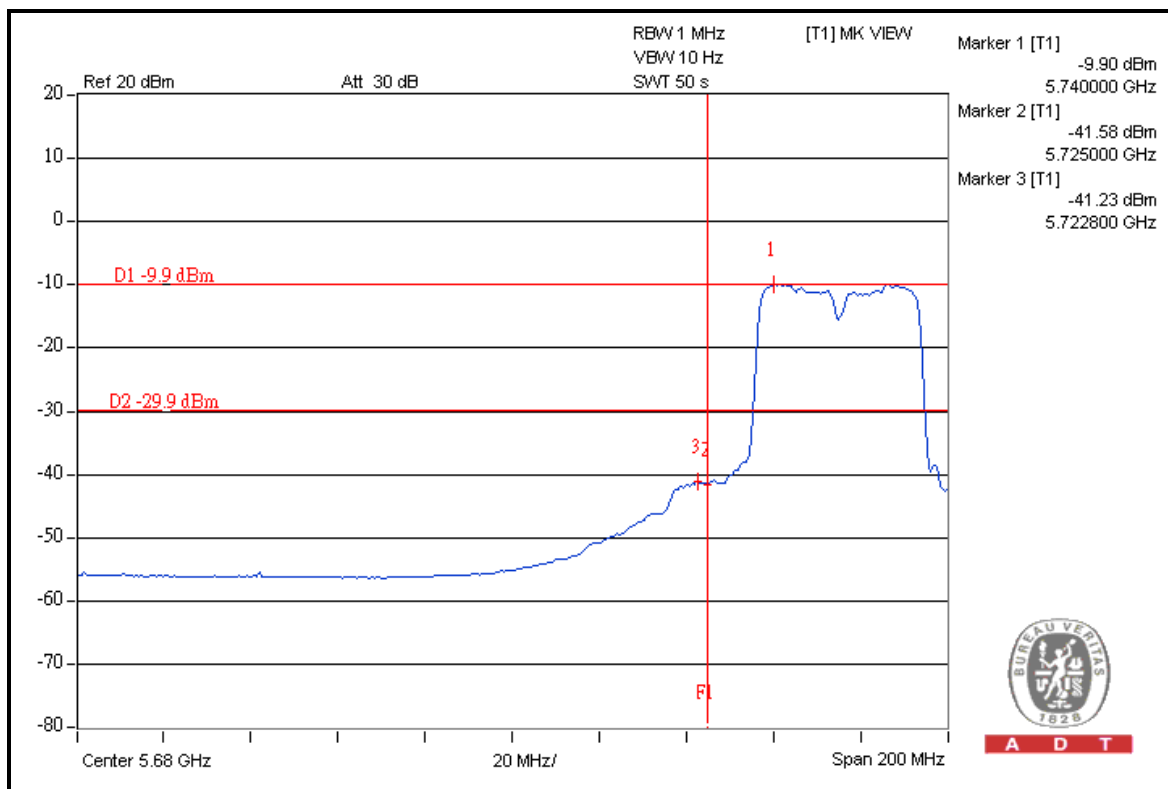
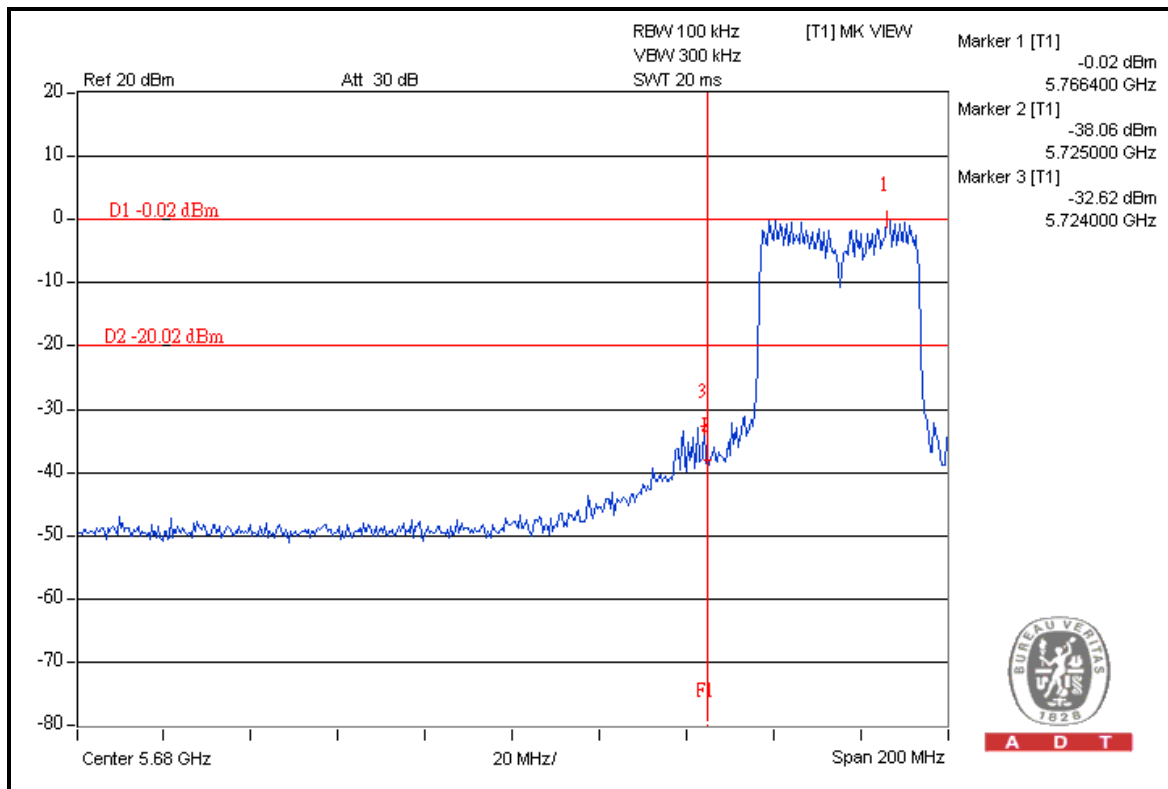



A D T

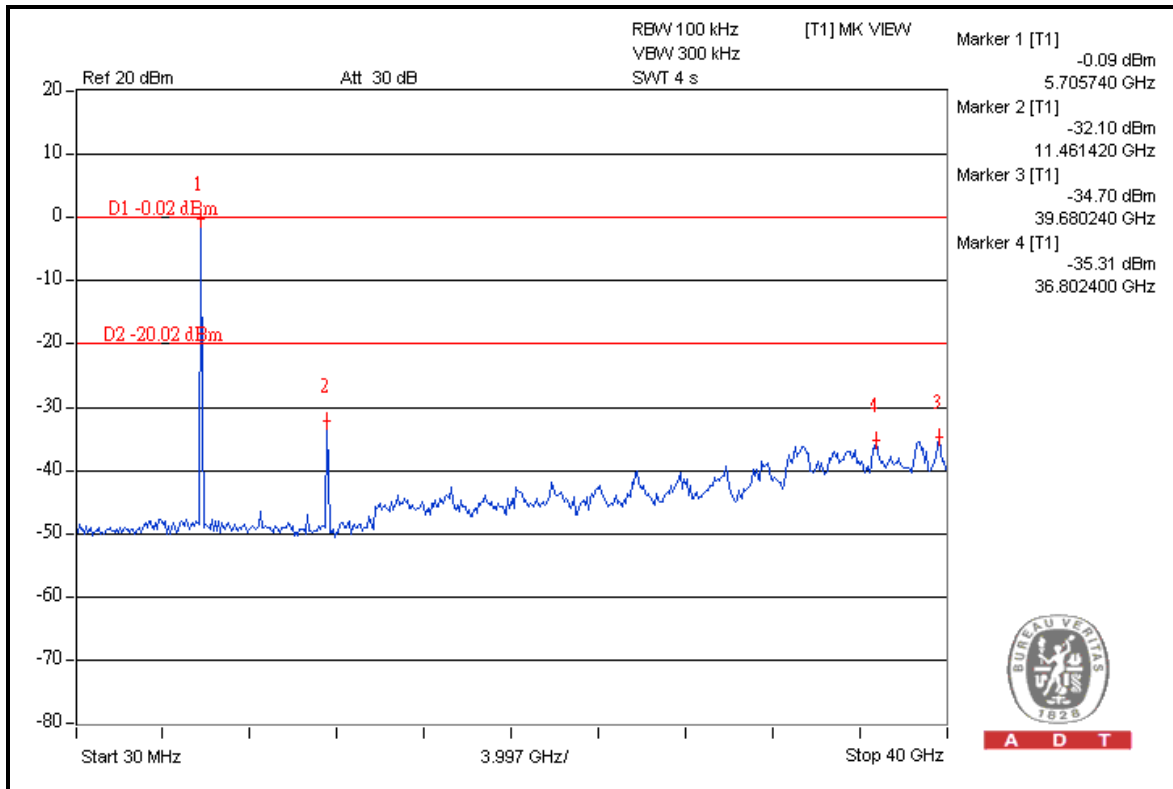

A D T

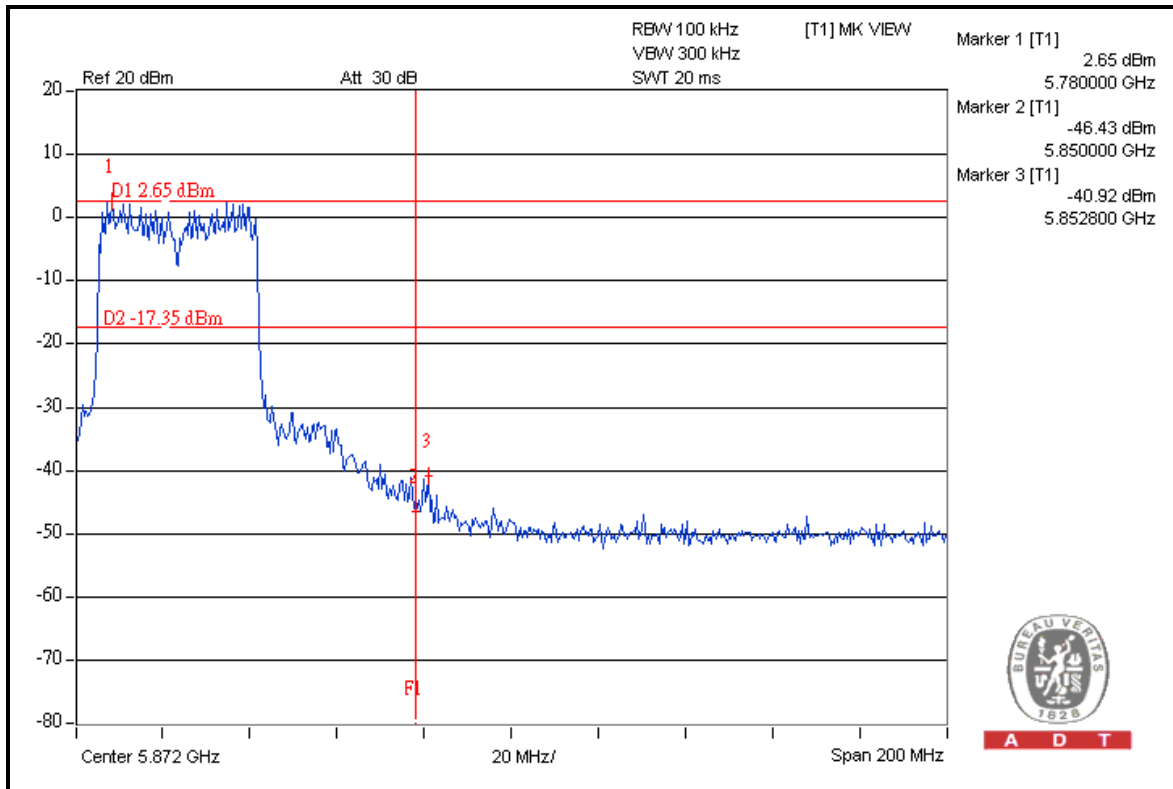

A D T



A D T

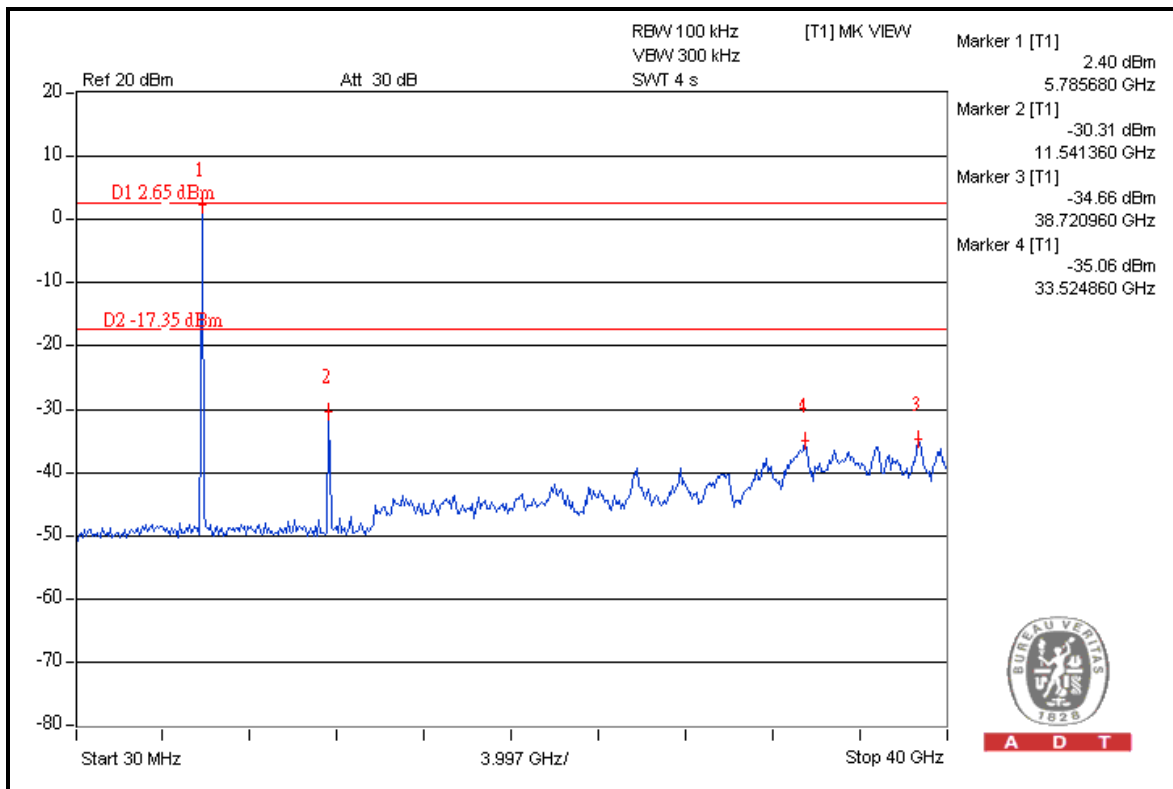
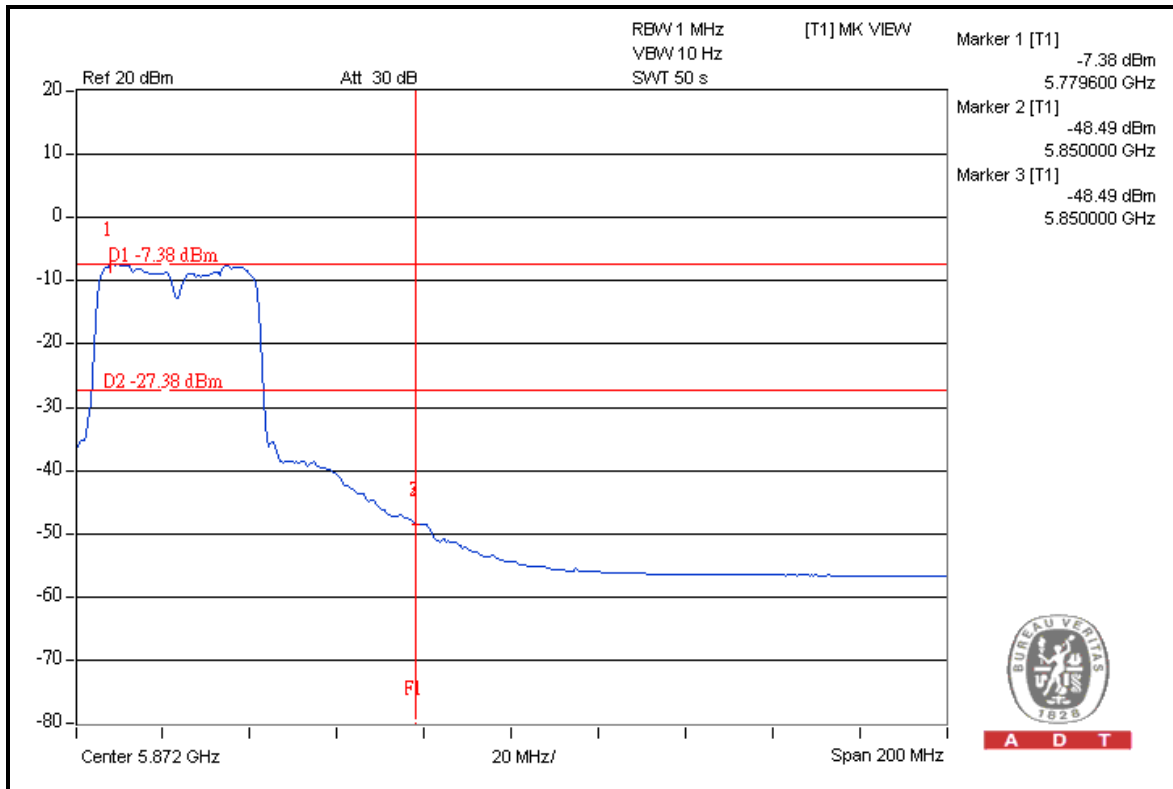



A D T

## 6. PHOTOGRAPHS OF THE TEST CONFIGURATION

Please refer to the attached file (Test Setup Photo).



A D T

## 7. INFORMATION ON THE TESTING LABORATORIES

We, Bureau Veritas Consumer Products Services (H.K.) Ltd., Taoyuan Branch, were founded in 1988 to provide our best service in EMC, Radio, Telecom and Safety consultation. Our laboratories are accredited and approved according to ISO/IEC 17025.

Copies of accreditation certificates of our laboratories obtained from approval agencies can be downloaded from our web site: [www.adt.com.tw/index.5/phtml](http://www.adt.com.tw/index.5/phtml). If you have any comments, please feel free to contact us at the following:

**Linko EMC/RF Lab:**

Tel: 886-2-26052180

Fax: 886-2-26051924

**Hsin Chu EMC/RF Lab:**

Tel: 886-3-5935343

Fax: 886-3-5935342

**Hwa Ya EMC/RF/Safety / Telecom Lab:**

Tel: 886-3-3183232

Fax: 886-3-3185050

**Web Site:** [www.adt.com.tw](http://www.adt.com.tw)

The address and road map of all our labs can be found in our web site also.



A D T

## **8. APPENDIX A - MODIFICATIONS RECORDERS FOR ENGINEERING CHANGES TO THE EUT BY THE LAB**

No any modifications are made to the EUT by the lab during the test.

**---END---**