

## Printhead Cleaning, cont'd.

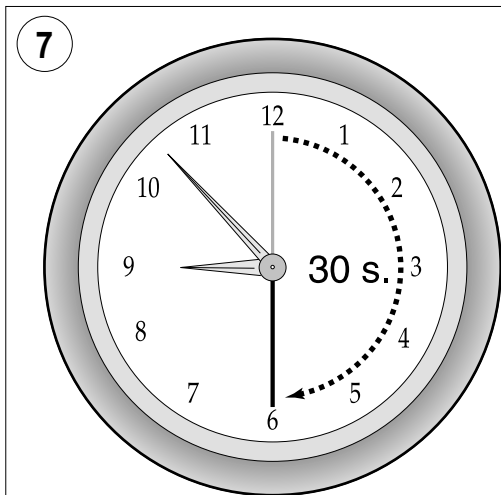

Wait for approx. 30 seconds to allow the cleaning fluid to dissolve the residue.

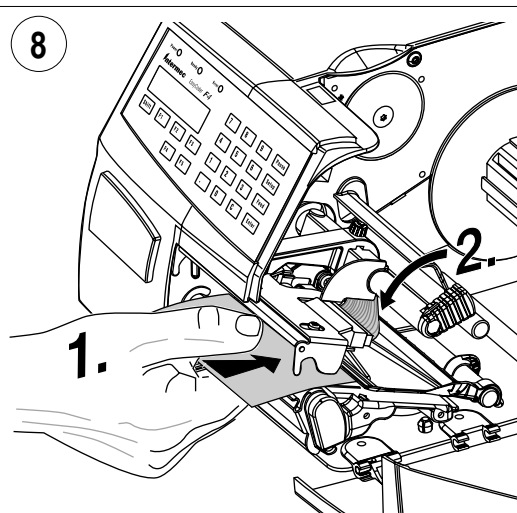

Insert most of the cleaning card under the printhead (1). Close the printhead (2).

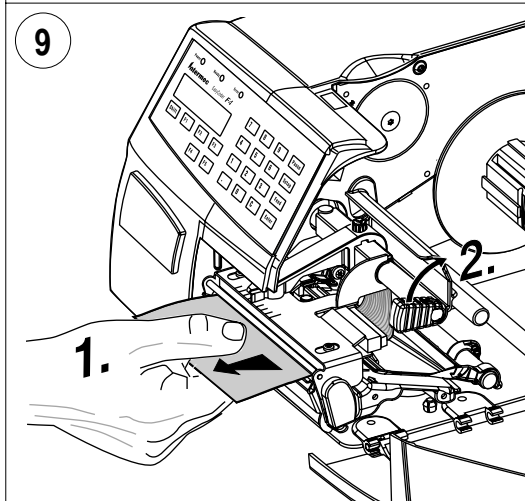

Pull out the cleaning card. If necessary, repeat the process with a new cleaning card.

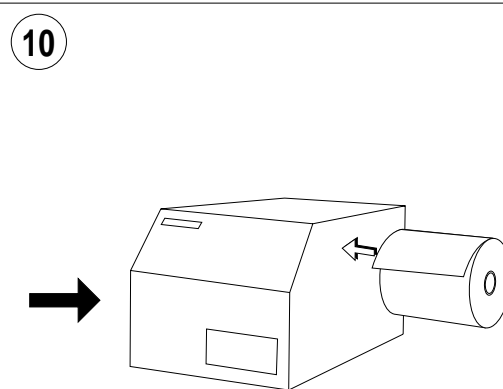

Allow the cleaned parts to dry before loading any paper.

# External Cleaning

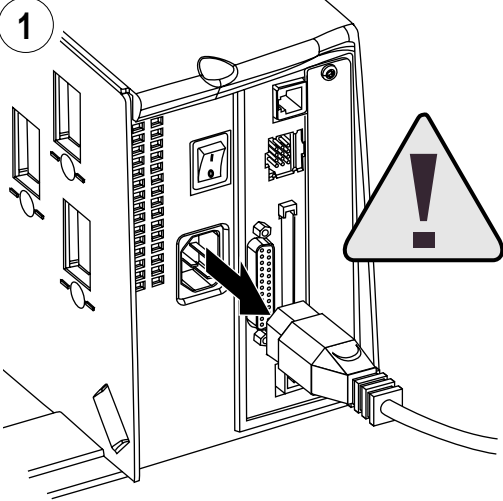
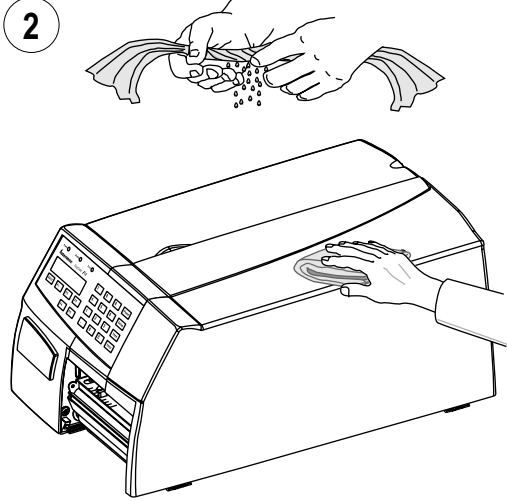
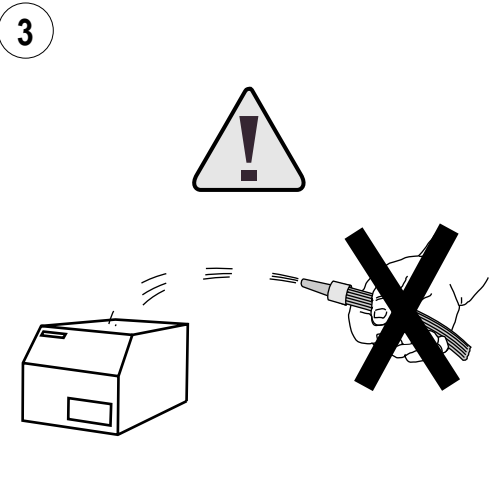
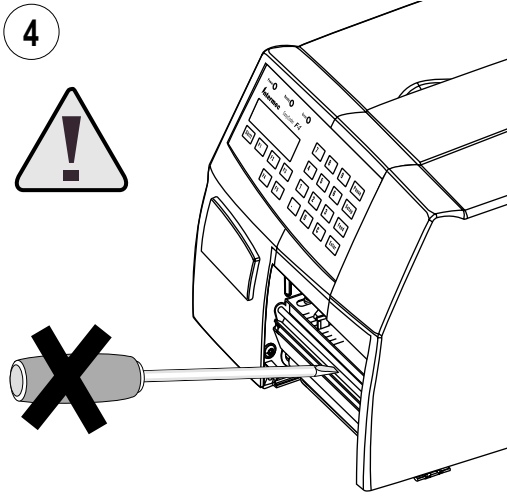
<p>1</p>  <p><i>Always remove the power cord before cleaning!</i></p>	<p>2</p>  <p><i>Wipe external surfaces with a soft cloth slightly moistened with water or a mild detergent.</i></p>
<p>3</p>  <p><i>Never spray the printer. Protect it from water when cleaning the premises.</i></p>	<p>4</p>  <p><i>Never use any sharp tools for removing stuck labels. The printhead and rollers are delicate.</i></p>

## Cleaning the Paper Guides

Both parts of the label stop sensor, which controls the paper feed, are covered by plastic guides. The guides are provided with seemingly non-transparent areas, through which the light between the two parts of the label stop sensor is transmitted. These areas (indicated by a shade of grey in illustration #2 below) must be kept clean from dust, stuck labels, and adhesive residue.

If the printer starts to feed our labels in an unexpected way, lift the upper guide – as described below – and check for anything that may block the beam of light (dust, stuck labels, adhesive residue etc.). If necessary, clean the guides using a cleaning card or a soft cloth soaked with isopropyl alcohol. Do not use any other the of chemical. Be careful not to scratch the guides.

*Caution!*  
Isopropyl alcohol [(CH<sub>3</sub>)<sub>2</sub>CHOH; CAS 67-63-0] is a highly flammable, moderately toxic and mildly irritating substance.

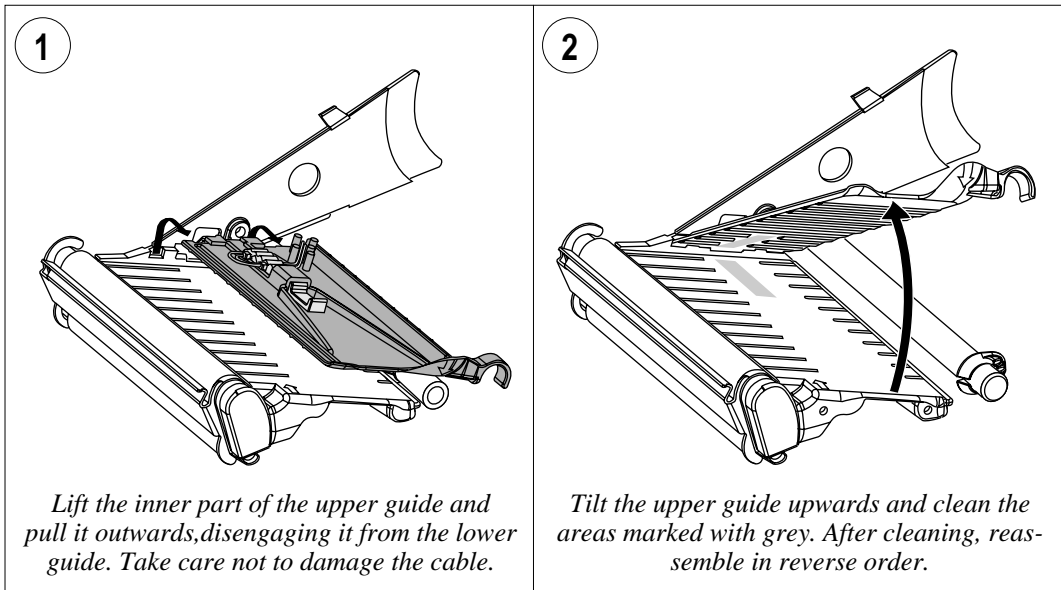

# Printhead Replacement

The printhead is subject to wear both from the direct thermal paper and from the rapid heating and cooling process during printing. Thus, the printhead will require periodical replacement.

Time between printhead replacements depends on the print images, the type of paper in use, the amount of energy to the printhead, and several other factors.

*Note!*

*While replacing the printhead, the power should be switched off.*

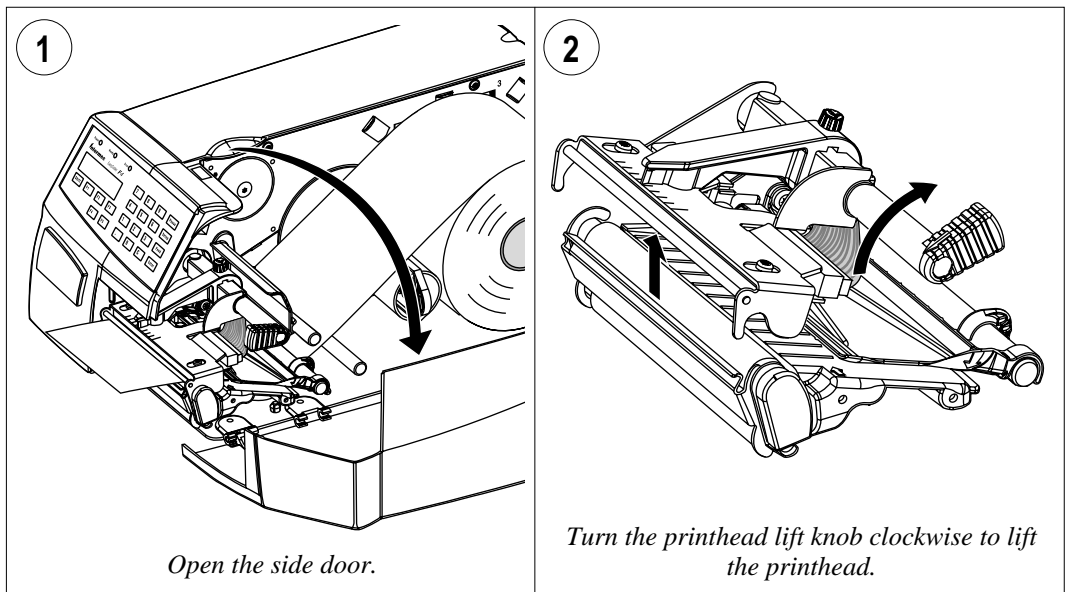

## Printhead Replacement, cont'd.

3

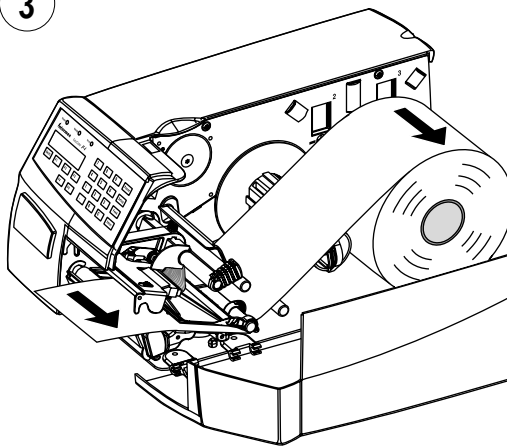

*Remove the paper, if any.*

4

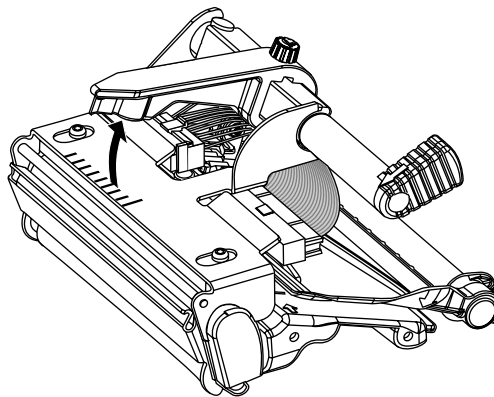

*Pull the printhead bracket away from the magnet in the pressure arm.*

5

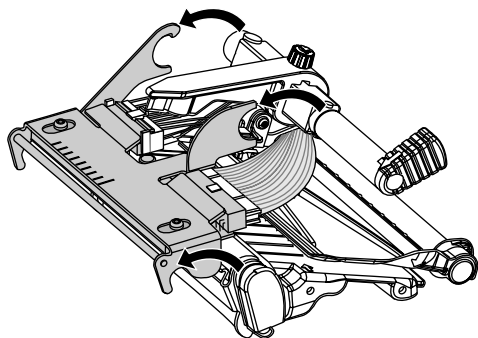

*Disconnect the printhead bracket from the print mechanism – as indicated by the arrows – and pull out the printhead as far as the cables allow.*

6

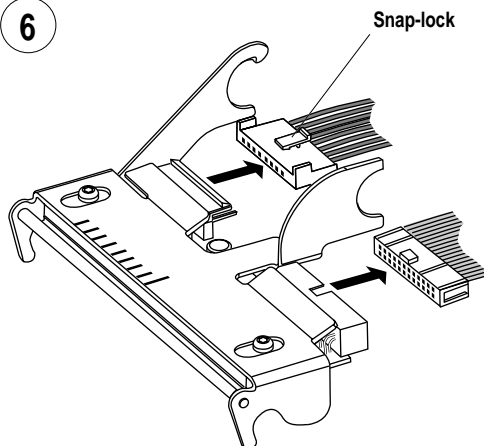

*Disconnect the cables from the printhead. Note the snap-lock on the inner connector. Pull at the connectors – not the cables!*

## Printhead Replacement, cont'd.

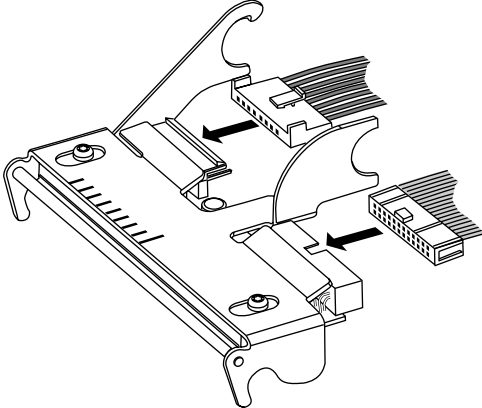
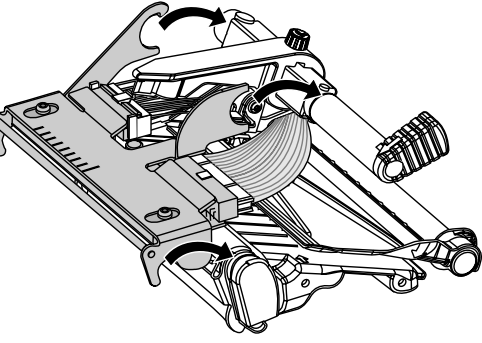
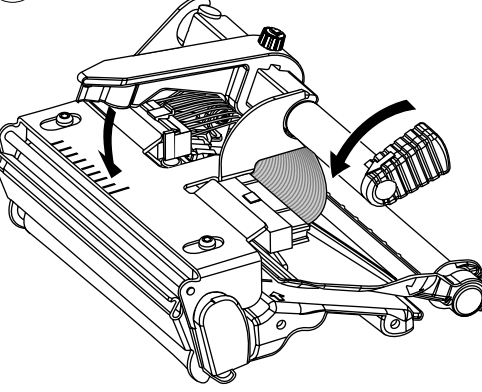
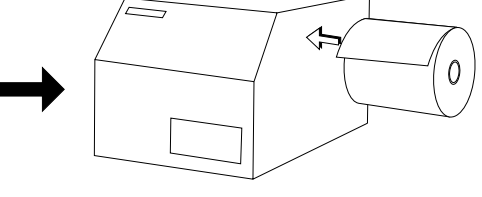
<p>7</p>  <p><i>Connect the two cables to the replacement printhead.</i></p>	<p>8</p>  <p><i>Put back the printhead in reverse order and check that the printhead cables run freely.</i></p>
<p>9</p>  <p><i>Close the printhead so the magnet engages the printhead bracket.</i></p>	<p>10</p>  <p><i>Load a new supply of paper as described earlier in this manual.</i></p>

# Adjustments

## Narrow Labels Adjustment

The printer is factory-adjusted for full size paper width. When using paper less than full width, it is recommended to adjust the pressure arm so it becomes centred on the paper. Thereby, an even pressure across the paper is obtained.

A poorly adjusted pressure arm may be detected by a weaker printout on the inner part of a less than full width paper. Similarly, when reverting to a wider paper, the arm should be adjusted, or the printout on the outer part of the paper could be weak.

To adjust the pressure arm, proceed as follows:

- Loosen the nut that holds the pressure arm. Move the arm inwards or outwards until the arrow on the tip of the arm becomes centre-aligned with the paper web.

*While moving the arm, push at the part where the nut is situated, not at the tip. If the arm is hard to move, lift the printhead and pull the printhead bracket free from the magnet in the arm.*

- After having centred the arm, lock it by tightening the nut.

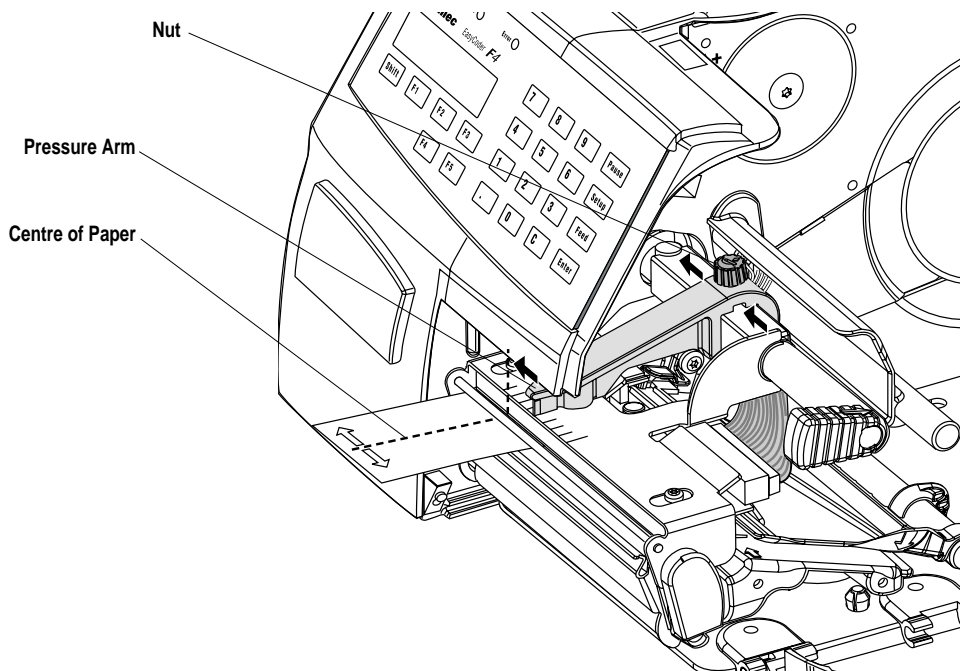

## Label Stop Sensor Position

The label stop/black mark sensor (LSS) is a photoelectric sensor that controls the printer's paper feed by detecting gaps between labels, slots in paper strip, or black marks, depending on the printer's setup in regard of media type (see chapter 6 "Setting Up the Printer"). A prerequisite is obviously that the LSS is aligned with the slots or black marks.

Thus, the LSS can be moved laterally between 5 fixed positions. There is one sensor on top of the upper paper guide and underneath the bottom of the print unit. These two guides must be set individually to the same position. Push them inwards as far as they go and then pull them out – one at the time – while counting the clicks from the snap-locks.

The various detection points of the sensor in relation to the inner edge of the paper are as follows:

One click out	3 mm	.118"
Two clicks out	8 mm	.315"
Three clicks out	12 mm	.472"
Four clicks out	16 mm	.639"
Five clicks out	20 mm	.787"

If using irregularly shaped labels, align the LSS with the front tips of the labels

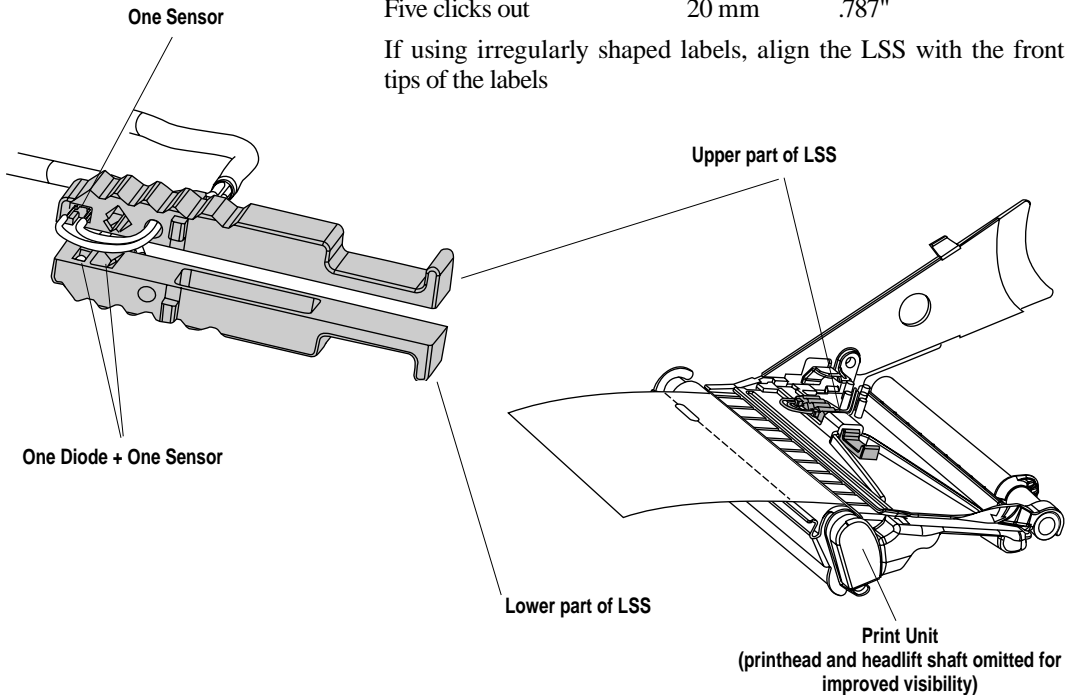



## Printhead Pressure

The pressure of the thermal printhead against the paper is factory adjusted. However, the use of thicker or thinner paper than normal could require the printhead pressure to be readjusted.

Using a flat-tipped screwdriver, turn the adjustment screw clockwise for increased pressure (+), or counter-clockwise for less pressure (-). Print a few labels, preferably test labels (see chapter 6 “Setting Up the Printer”), and check the printout. Increased pressure generally gives a darker printout and vice versa. Repeat until the desired result is obtained.

To return to the factory setting, tighten the screw (+) as far as it goes and then loosen it (-) six (6) full turns.

*Note!*

*Do not use a higher printhead pressure than necessary, because it may increase the wear of the printhead and thus shorten its life.*

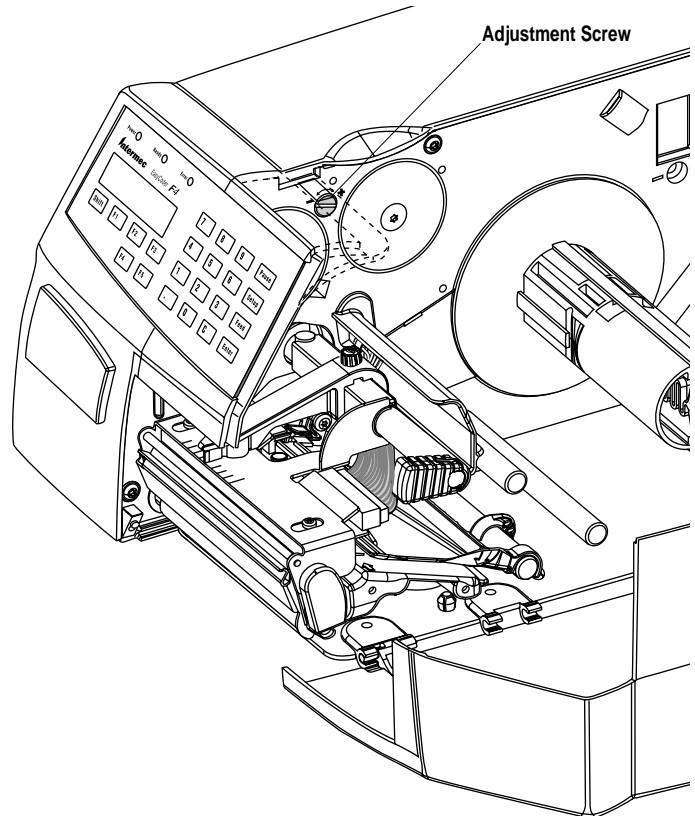

# Technical Data

<b>Printing</b>		
Print Technique	Direct Thermal	
Printhead Resolution	8 dots/mm (203.2 dpi)	
Print Speed (variable)	100 – 200 mm/sec. ( $\approx$ 4 – 8"/sec.)	
Print Width (max)	104 mm (4.095")	= 832 dots
Print Length (max)	32767 dots = 409.5 cm <sup>1</sup>	
Media Width (min/max)	25 – 114.3 mm (1 – 4.5")	Standard paper guide
Media Width (min/max)	40 – 114.3 mm (1.57 – 4.5")	Quick-Load guides
Paper Roll Diameter (max)	213 mm (8.38")	Short door/no rewind
Paper Roll Core Diameter	38 – 40 mm (1.5") or 76 mm (3")	
Print Directions	4	
<b>Modes of Operation</b>		
Tear Off	Yes	
Peel Off	Optional	Requires Rewind Unit
<b>Firmware</b>		
Operating System	Intermec Fingerprint 7.31	Incl. Direct Protocol
Smooth Fonts	TrueDoc and TrueType fonts	
Built-in scalable fonts (std)	15	Unicode fonts <sup>2</sup>
Built-in bar code symbologies (std)	36	
Startup Program (std)	Intermec Shell 4.4	
<b>Physical Measures</b>		
Dimensions (W x L x H)	244 x 397 x 178 mm (9.61 x 15.63 x 7.00")	w. Long side door
Weight (excluding media)	$\approx$ 7 kgs (15.5 lbs)	Depending on model
Ambient Operating Temperature	+5°C – +40° C (+41°F – +104° F)	
Humidity	20 – 80% non-condensing	
<b>Electronics</b>		
Microprocessor	32 bit RISC	
On-board Flash SIMMs	1 – 2	Std. 1 x 2 Mbytes
On-board DRAM SIMM	1	Std. 4 Mbytes
Real-Time Clock	Option	10+ years life
<b>Power Supply</b>		
Mains Voltage	>90 – <264 V AC, 45 – 65 Hz	
PFC Regulation	IEC 61000-3-2	
Maximum Power Consumption	Continuous 140 W; Peek 300W	

## Technical Data, cont'd.

<b>Sensors</b>		
Label Gap/Black Mark/Out of Paper	Yes	5 fixed positions
Printhead Lifted	Yes	
<b>Controls</b>		
Control Lamps	3	
Display	2 x 16 character LCD w. background light	
Keyboard	22 keys membrane switch type	
Print Button	1	
Beeper	Yes	
<b>Data Interfaces</b>		
Serial	1 x RS 232C + 1 x USB	
Bar Code Wand	Yes	
Electronic Keys	2	For setup
Connection for Optional Interface Boards	1	Future option
Memory Card Adapter	1	
<b>Accessories and Options</b>		Flash or SRAM cards
RFID Module	Option	
Rewind Unit	Option	For peel-off operation
Paper Supply Spool	Option	Replaces hanger
3" Adapter for Paper Supply Spool	Option	
Short Side Door	Option <sup>3</sup>	
Long Side Door	Option <sup>3</sup>	
Label Taken Sensor	Option	
Real-Time Clock	Option	10+ years life
Quick-Load Guides	Standard	Fitted in some models
RS 232C Cable	Option	
EasySet Bar Code Wand	Option	For quick setup
Parallel Interface Board	Option	IEEE 1284
Double Serial Interface Board	Option	
Industrial Interface Board	Option	
EasyLAN 100I Interface Board	Option	Ethernet
External Alphanumeric Keyboard	Option	
Flash Memory Cards	Option	≤ 64 Mbit (8 MB)
Electronic Keys	Option	
1. The max. print length is also restricted by the amount of free DRAM memory.		
2. Latin, Greek, and Cyrillic fonts according to Unicode standard are included.		
3. Depending on model, the printer may be delivered with either a long or a short side door.		

# Media Specifications

## Direct Thermal Labels

Intermec offers two quality grades of **direct thermal** paper for the EasyCoder range of printers:

- **Premium Quality:** Top-coated papers with high demands on printout quality and resistance against moisture, plasticisers and vegetable oils. Examples...
  - Top Board
  - Premium
  - Duratherm II,
  - Duratherm II Tag
  - Duratherm Ltg.
  - Duratherm IR
- **Economy Quality:** Non top-coated papers with less resistance to moisture, plasticisers and vegetable oils. In all other respects, it is equal to *Premium Quality*. Examples...
  - Economy
  - Eco Board

# Paper Roll Size

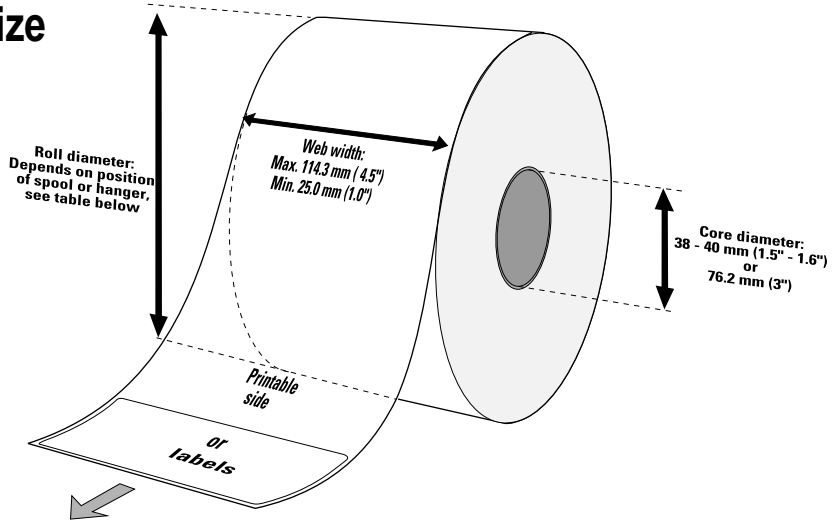

### Core

Diameters: 38 – 40 mm (1.5") or 76.2 mm (3")  
Width: Must not protrude outside the web.

*The web must be wound up on the core in such a way that the printer can pull the end of the web free.*

### Roll

Max. diameter (internal supply only):

- Position 1 152 mm (6.00")
- Position 2 213 mm (8.38")
- Position 3 203 mm (8.00")
- Max. width: 114.3 mm (4.50")
- Min. width (standard): 25 mm (1.00")
- Min. width (Quick-Load): 40 mm (1.57")
- Max. web thickness: 175 µm (0.007")

The maximum recommended web thickness is 175µm. A thicker web may be used, but print quality will be reduced. Web stiffness is also important and must be balanced against web thickness to maintain print quality.

Paper rolls fitted inside the printer should be wound with the printable side facing outwards.

The paper supply must not be exposed to dust, sand, grit, etc. Any hard particles, however small, can damage the printhead.

# Paper

## Non-Adhesive Strip



<b>⇐ a ⇒ Web Width:</b>		
Maximum:	114.3 mm	(4.50")
Minimum (standard):	25.0 mm	(1.00")
Minimum (Quick-Load):	40.0 mm	(1.57")

**Media Type Setup:**

- Fix length strip
- Var length strip

## Paper, cont'd.

### Self-Adhesive Strip

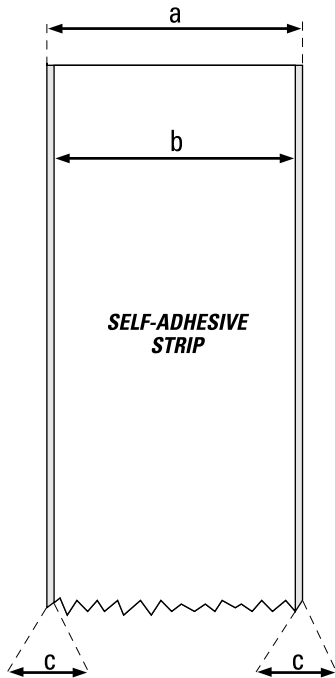

⇐ **a** ⇒ **Web Width** (including backing paper):

Maximum: 114.3 mm (4.50")

Minimum (standard): 25.0 mm (1.00")

Minimum (Quick-Load): 40.0 mm (1.57")

⇐ **b** ⇒ **Backing Paper**

The backing paper must not extend more than a total of 1.6 mm (0.06") outside the paper and should protrude equally on both sides.

⇐ **c** ⇒ **Paper Width** (excluding backing paper):

Maximum: 112.74 mm (4.43")

Minimum: 23.8 mm (0.94")

#### Media Type Setup:

- Fix length strip
- Var length strip

## Paper, cont'd.

### Self-Adhesive Labels

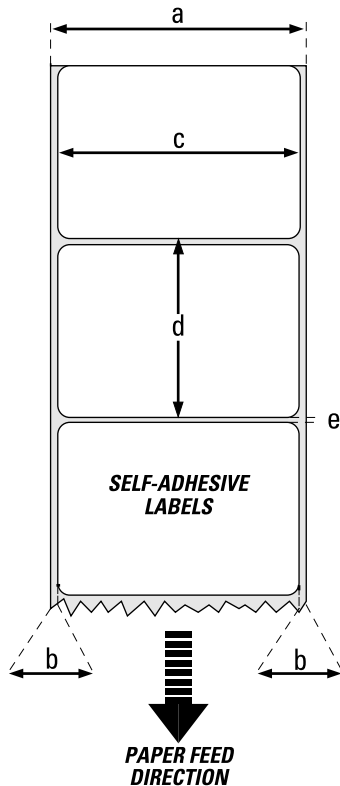

⇐ **a** ⇒ **Web Width** (including backing paper):

Maximum:	114.3 mm	(4.50")
Minimum (standard):	25.0 mm	(1.00")
Minimum (Quick-Load):	40.0 mm	(1.57")

⇐ **b** ⇒ **Backing Paper**

The backing paper must not extend more than a total of 1.6 mm (0.06") outside the paper and should protrude equally on both side. Recommended min. transparency: 40% (DIN 53147).

⇐ **c** ⇒ **Label Width** (excluding backing paper):

Maximum:	112.7 mm	(4.43")
Minimum:	23.8 mm	(0.94")

⇐ **d** ⇒ **Label Length:**

Minimum:	8.0 mm	(0.32")
Max label length:	depends on DRAM size	

*Under favourable circumstances, a minimum label length down to 4 mm (0.16") could be used. It requires the sum of the label length (d) and the label gap (e) to be larger than 7 mm (0.28"), that batch printing is used, and that no pull back of the paper is performed. Intermec does not guarantee that such short labels will work, but it is up to the user to test this in his unique application.*

⇐ **e** ⇒ **Label Gap:**

Maximum:	21.3 mm	(0.83")
Recommended:	3.0 mm	(0.12")
Minimum:	1.2 mm	(0.05")

The Label Stop Sensor must be able to detect the extreme front edges of the labels. It can be moved between 5 fixed positions at the following distances from the inner edge of the paper.

3 mm	(.118")
8 mm	(.315")
12 mm	(.472")
16 mm	(.639")
20 mm	(.787")

**Media Type Setup:**

- Label (w gaps)



# Paper, cont'd.

## Tickets with Gap

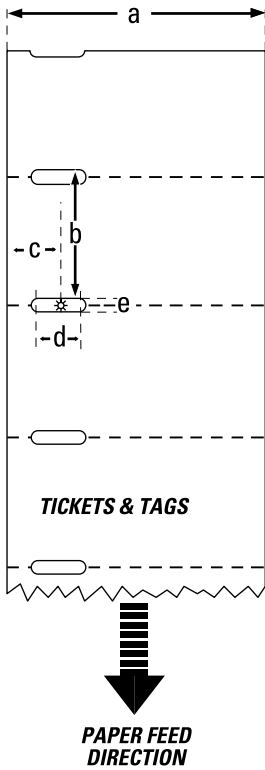

⇐ **a** ⇒ **Web Width:**

Maximum:	114.3 mm	(4.50")
Minimum (standard):	25.0 mm	(1.00")
Minimum (Quick-Load):	40.0 mm	(1.57")

⇐ **b** ⇒ **Copy Length:**

Min. length between slots:	8.0 mm	(0.32")
Max. length between slots:	depends on DRAM size	

*Under favourable circumstances, a minimum ticket length down to 4 mm (0.16") could be used. It requires the sum of the copy length (b) and the detection slit height (e) to be larger than 7 mm (0.28"), that batch printing is used, and that no pull back of the paper is performed. Intermec does not guarantee that such short labels will work, but it is up to the user to test this in his unique application.*

⇐ **c** ⇒ **LSS Detection Position:**

Five fixed positions (distance from inner edge of paper):

3 mm	(.118")
8 mm	(.315")
12 mm	(.472")
16 mm	(.639")
20 mm	(.787")

⇐ **d** ⇒ **Detection Slit Length:**

The length of the detection slit (excluding corner radii) must be minimum 2.5 mm (0.10") on either side of the LSS detection position (e).

⇐ **e** ⇒ **Detection Slit Height:**

Maximum:	21.3 mm	(0.83")
Recommended:	1.6 mm	(0.06")
Minimum:	1.2 mm	(0.05")

**Media Type Setup:**

- Ticket (w gaps)

*Do not allow any perforation to break the edge of the web, as this may cause the web to split, resulting in a paper jam.*

## Paper, cont'd.

### Tickets with Black Mark

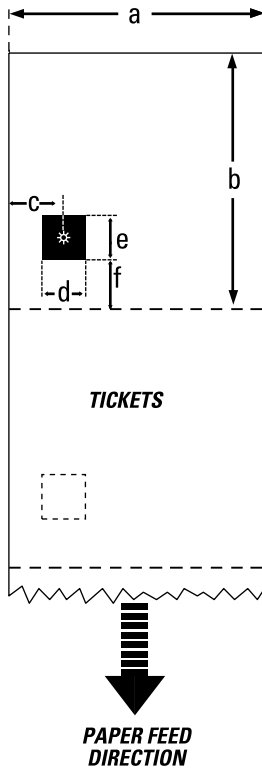

#### ⇐ a ⇒ Web Width:

Maximum:	114.3 mm	(4.50")
Minimum (standard):	25.0 mm	(1.00")
Minimum (Quick-Load):	40.0 mm	(1.57")

#### ⇐ b ⇒ Copy Length:

Minimum:	20.0 mm	(0.8")
Maximum:	depends on DRAM size	

#### ⇐ c ⇒ LSS Detection Position:

Five fixed positions (distance from inner edge of paper):

3 mm	(.118")
8 mm	(.315")
12 mm	(.472")
16 mm	(.639")
20 mm	(.787")

#### ⇐ d ⇒ Black Mark Width:

The detectable width of the black mark should preferably be at least 5.0 mm (0.2") on either side of the LSS detection point.

#### ⇐ e ⇒ Black Mark Length:

Maximum:	21.3 mm	(0.83")
Common:	12.5 mm	(0.5")
Minimum:	5.0 mm	(0.2")

#### ⇐ f ⇒ Black Mark Y-Position:

It is recommended to place the black mark as close to the front edge of the ticket as possible and use a negative Stop Adjust value to control the paper feed, so the tickets can be properly torn or cut off.

#### Media Type Setup:

- Ticket (w mark)

*Important! Preprint that may interfere with the detection of the black mark should be avoided on the back of the paper. However, the LBLCOND statement allows the sensor to be temporarily disabled during a specified amount of paper feed in order to avoid unintentional detection, see Intermec Fingerprint manuals.*

*The black mark should be non-reflective carbon black on a whitish background.*

*Do not allow any perforations to break the edge of the web, as this may cause the web to split, resulting in a paper jam.*

# Interfaces

## RS 232C Interface

The EasyCoder F4 has – as standard – two serial communication interfaces: RS 232C on "uart1:" and USB (see next page).

### Protocol

Default setup:

Baudrate: 9600  
 Char. length 8 bits  
 Parity: None  
 Stop bits: 1  
 RTS/CTS Disabled  
 ENQ/ACK: Disabled  
 XON/XOFF: Disabled (both ways)  
 New Line: CR/LF

To change the serial interface settings, see chapter 6 “Setting Up the Printer”.

### Interface Cable

Computer end: DB-9 or DB-25 female connector (PC)  
 Printer end: DB-25 male connector

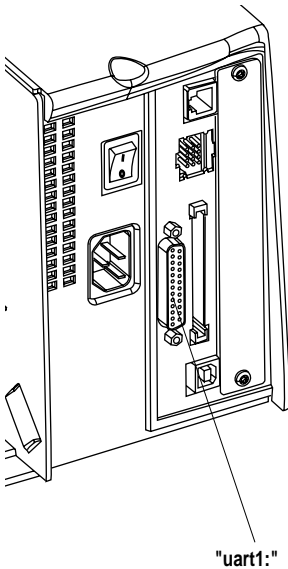

Host		EasyCoder F4			Host	
Signal	DB-9	DB-25	Signal	DB-25	DB-25	Signal
	1	1		1	1	shield
RXD	2	2	TXD	2	3	RXD
TXD	3	3	RXD	3	2	TXD
CTS	8	4	RTS	4	5	CTS
RTS	7	5	CTS	5	4	RTS
		6	DSR	6	20	DTR
GND	5	7	Signal GND	7	7	GND
		16	+ 5V <sup>1</sup>	16		
DSR	6	20	DTR	20	6	DSR
		22	RI	22		

<sup>1/</sup>. The external +5V is limited to 200 mA and is automatically turned off at overload. It is intended to drive e.g. an external alphanumeric keyboard connected to the RS 232C port.

## USB Interface

*USB = Universal Serial Bus*

The EasyCoder F4 has – as standard – one USB communication port. To use the USB interface for printing from a PC, you need a special USB printer driver installed in your PC.

Using an USB Class A - B cable, connect the Class A end to your PC or hub and the Class B end to your EasyCoder F4 printer.

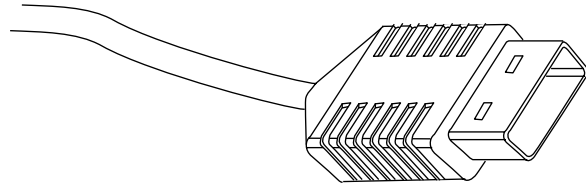
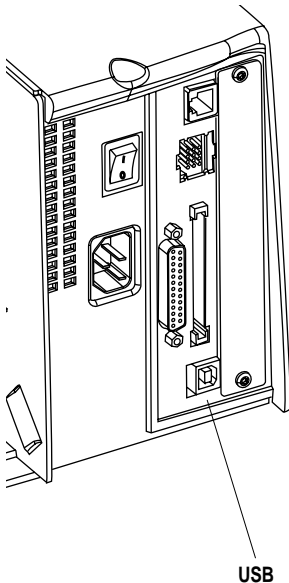

*USB Class A connector.  
Connect to PC or hub.*

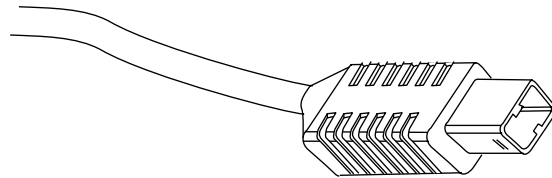

*USB Class B connector.  
Connect to USB receptacle on the printer's rear plate.*

**Note:**

*The USB interface is presently not supported by the Intermec Fingerprint firmware (v. 7.31).*

# Double Serial Interface Board

The EasyCoder F4 can optionally be fitted with an extra double serial interface board, which provides the printer with two more serial ports; "uart2:" and "uart3:". These ports can be configured for various types of serial communication in combination according to the customer's request. Use the Intermec Fingerprint instruction SETSTDIO to select standard IN and OUT ports (by default "uart1:" is both std IN and OUT port)<sup>1/</sup>.

- |                     |                     |
|---------------------|---------------------|
| <b>"uart2:"</b>     | <b>"uart3:"</b>     |
| RS 232C             | RS 232C             |
| RS 422 Non-isolated | RS 422 Non-isolated |
| RS 422 Isolated     | 20 mA Current Loop  |
| RS 485              |                     |

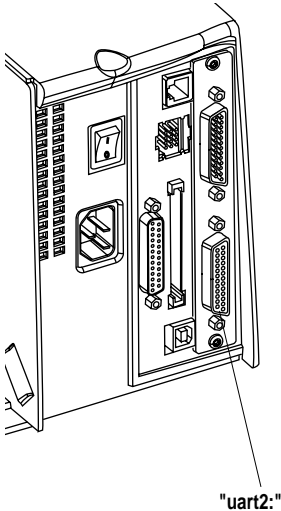

### "uart2:" Serial Port

The communication ports "uart2:" uses a female DB 25 connector.

Pin	Signal Name	Description
1		Not connected
2	TxD	RS 232 Transmitter
3	RxD	RS 232 Receiver
4	RTS	RS 232 Request To Send
5	CTS	RS 232 Clear To Send
6	DSR	RS 232 Data Set Ready
7	GND	Ground
8-14		Not connected
15	+RS422I	+RS 422 Receive
16	+5V	5 Volt for external use (max. 200 mA) <sup>1/</sup>
17	-RS422I	-RS 422 Receive
18		Not connected
19	+RS422O/+RS485	+RS 422 Transmit/+RS 485
20	DTR	RS 232 Data Terminal Ready
21	-RS422O/-RS485	-RS 422 Transmit/-RS 485
22	RI	RS 232 Ring Indicator
23	Shield	Optional shield for RS 422 and RS 485
24-25		Not connected

<sup>1/</sup>. Intermec Shell either automatically sets the correct std IN and OUT port when an application is selected, e.g. a Windows driver, or prompts you to select one, see chapter 8.

<sup>1/</sup>. The external 5V is automatically turned off at overload.

## Double Serial Interface Board, cont'd.

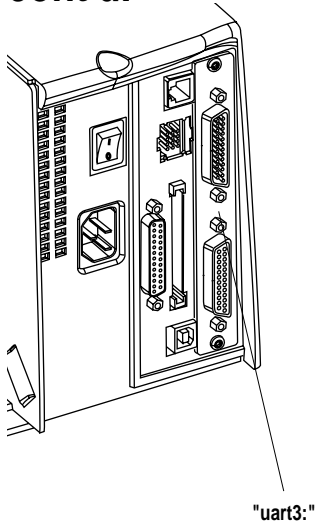

### "uart3:" Serial Port

The communication ports "uart3:" uses a male DB 25 connector.

Pin	Signal Name	Description
1		Not connected
2	TxD	RS 232 Transmitter
3	RxD	RS 232 Receiver
4	RTS	RS 232 Request To Send
5	CTS	RS 232 Clear To Send
6	DSR	RS 232 Data Set Ready
7	GND	Ground
8		Not connected
9	+20M1	+20 mA current loop
10	-20M1	-20 mA current loop
11	+TXD	+TXD 20 mA current loop
12	-TXD	-TXD 20 mA current loop
13	+20M2	+20 mA current loop (printer active receiver)
14	-20M2	-20 mA current loop (printer active receiver)
15	+RS422I	+RS 422 Receive
16	+5V	5 Volt for external use (max. 200 mA) <sup>1</sup>
17	-RS422I	-RS 422 Receive
18	+RxD	+TXD 20 mA current loop
19	+RS422O/+RS485	+RS 422 Transmit/+RS 485
20	DTR	RS 232 Data Terminal Ready
21	-RS422O/-RS485	-RS 422 Transmit/-RS 485
22	RI	RS 232 Ring Indicator
23	Shield	Optional shield for RS 422 and RS 485
24		Not connected
25	-RxD	-TXD 20 mA current loop

<sup>1</sup>/. The external 5V is automatically turned off at overload.

# IEEE 1284 Parallel Interface Board

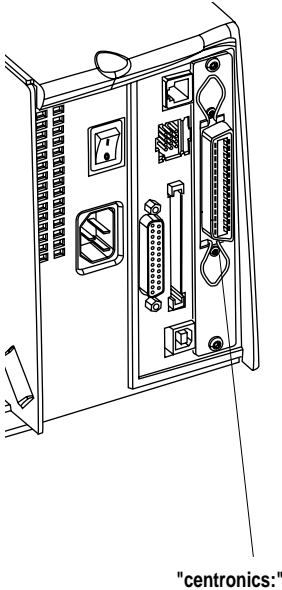

The EasyCoder F4 can optionally be fitted with an IEEE 1284-I compatible parallel interface board<sup>1</sup>. The parallel port is addressed in Intermec Fingerprint as device "centronics:". Select "centronics:" as standard IN port by means of the instruction SETSTDIO (by default, "uart1:" in std IN port)<sup>2</sup>.

### Interface Cable Connectors

Computer end: Depends on type of host computer.  
 Printer end: 36 pin female IEEE 1284B Centron

Pin	Signal Name
1	DStrobe
2-9	Data 0-7
10	Ack
11	Busy
12	PE
13	Select
14	AF
15	Not connected
16	Ground
17	Screen
18	+5V Ext
19-30	GND
31	Init
32	Error
33-35	Not connected
36	Selectin

<sup>1</sup>/ Nibble, byte, ECP and EPP from printer to host are presently not supported.

<sup>2</sup>/ Intermec Shell either automatically sets the correct std IN and OUT port when an application is selected, e.g. a Windows driver, or prompts you to select one, see chapter 8.

## Industrial Interface Board

The EasyCoder F4 can optionally be fitted with an Industrial Interface Board, that provides the printer with one extra serial communication port ("uart2:"), which can be configured for one of the following alternatives

- RS 232C
- RS 422 Non-isolated
- RS 422 Isolated
- RS 485

This port is identical to "uart2:" on the double serial interface board.

The Industrial Interface Board also has a female DB-44 connector with...

- 8 digital IN ports with optocouplers
- 8 digital OUT ports with optocouplers
- 4 OUT ports with relays.

Refer to the installation instructions for the Industrial Interface Board for further information.

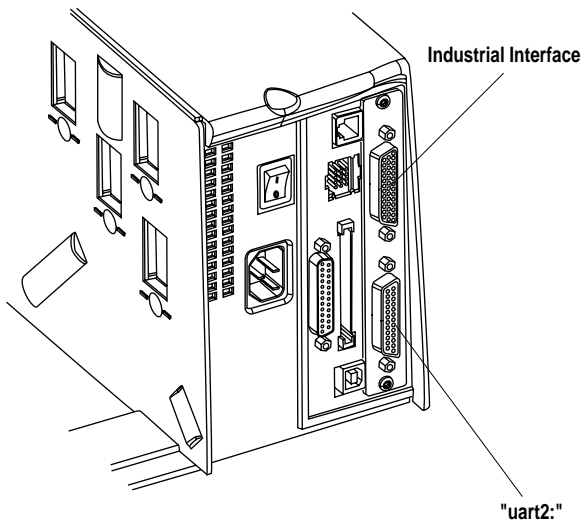



## EasyLAN 100i Interface Board

The Intermec EasyLAN 100i Ethernet interface board provides the printer with a 10BaseT Ethernet or 100BaseTX Fast Ethernet network connection. You can communicate with the printer via a LAN (Local Area Network) or provide the printer with its own home page, so you can reach the printer via internet on the world wide web (www).

EasyLAN 100i supports most major computer systems and environments. You can assign passwords to restrict both login and printer access. The internal EasyLAN 100i web pages allow you to continuously monitor printer status and to upgrade the flash memory of the printer when new firmware becomes available.

EasyLAN 100i supports SNMP for remote monitoring.

When an EasyLAN 100i interface board is fitted in the printer, some extra menus will be added to the Setup Mode (see chapter 7 “Setup Mode”). The Ethernet port is addressed in Intermec Fingerprint 7.3 or later as device "net1:" (communication channel 5).

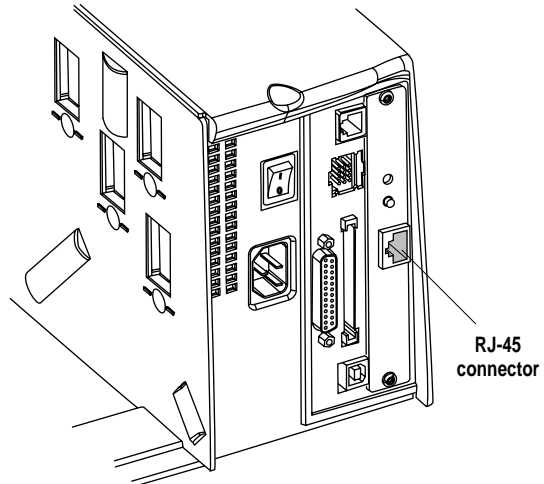

# EasySet Bar Code Wand Setup

## Connection and Operation

1. Connect the optional EasySet bar code wand to the receptacle on the printer's rear plate.
2. Read the appropriate bar code to set up the printer. Hold the wand like a pencil and move it rather swiftly across the bar code.

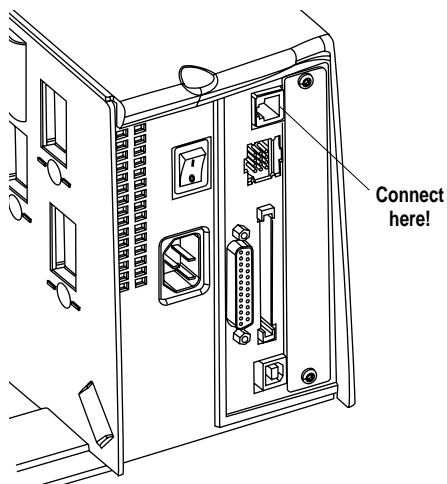

3. When the bar code has been accepted, the printer emits a short beep and the Ready control lamp on the printer's front blinks briefly.
4. This manual only contains a selection of setup options. For information on how to produce your own setup bar codes, please refer to the Intermec Fingerprint 7.31 Reference Manual.

## Serial Communication on "uart1:"

### Baudrate

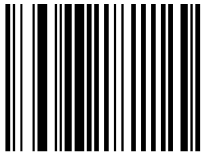

4800

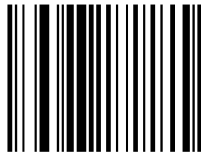

9600

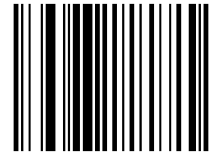

19200



38400



57600



115200

---

### Char. Length



7

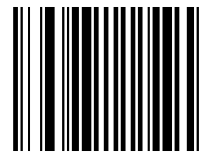

8

---

### Parity

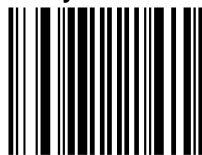

None

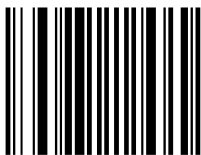

Even

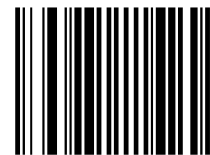

Odd

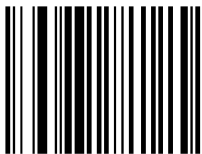

Mark

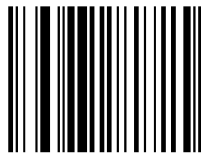

Space

## Serial Communication on "uart1:", cont'd.

### No. of Stop Bits

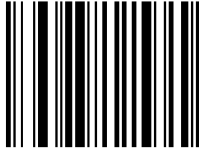

1

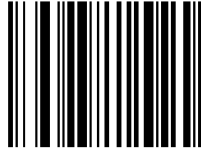

2

### Reset comm. to default

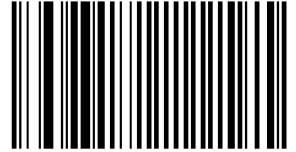

9600-8-none-1

---

### RTS/CTS

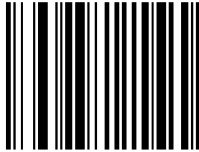

Enable

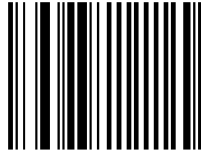

Disable

---

### ENQ/ACK

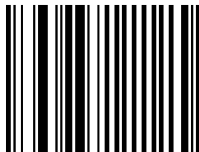

Enable

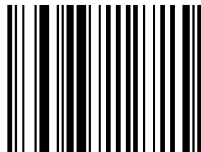

Disable

---

### XON/XOFF, Data to Host

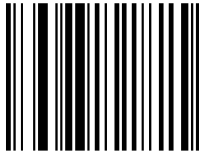

Enable

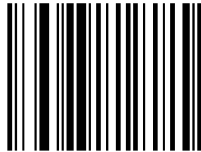

Disable

---

## Serial Communication on "uart1:", cont'd.

### XON/XOFF, Data from Host

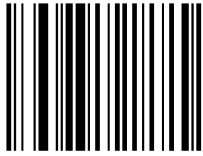

Enable

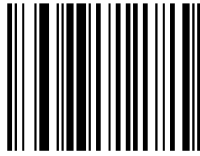

Disable

---

### New Line

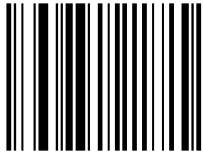

CR/LF

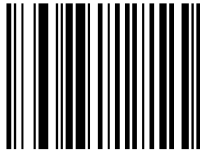

LF

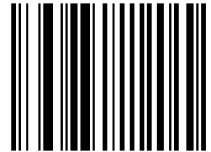

CR

---

## Start- and Stopadjust

### Tear Off



-100/0

### Peel Off

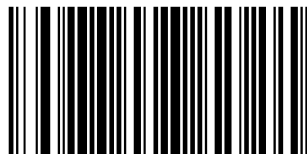

-56/-44

### Default



0/0

## Contrast

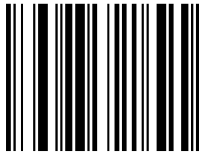

-10%

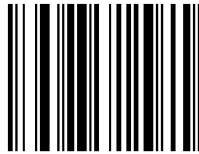

-8%

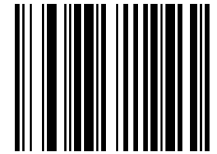

-6%

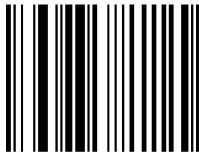

-4%

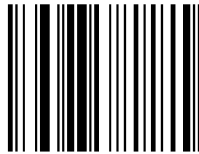

-2%



0%

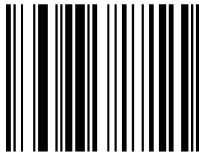

+2%

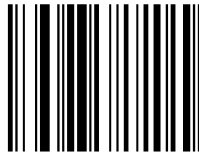

+4%



+6%

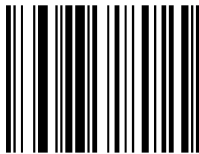

+8%

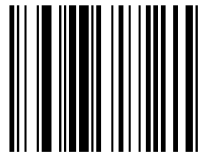

+10%

## Test Labels



#1

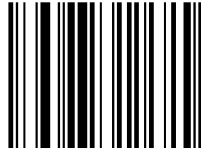

#2

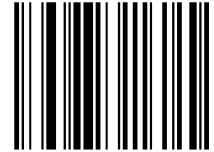

#3

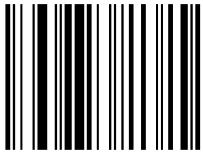

#4

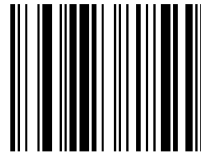

#5

---

## Media Width



43 mm



53 mm



70 mm

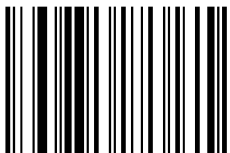

84 mm



85 mm

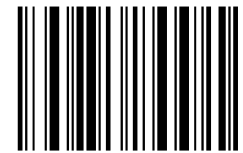

87 mm

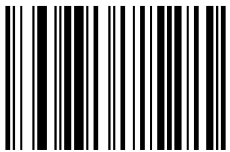

90 mm

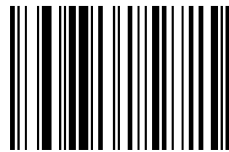

102 mm

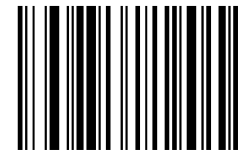

104 mm

## Media Length

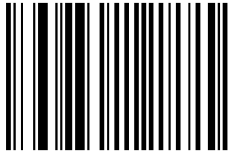

25 mm

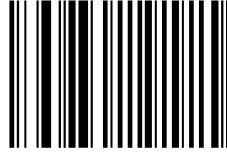

28 mm

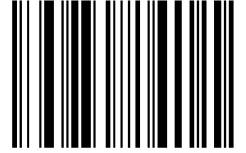

49 mm

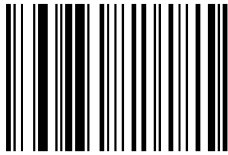

55 mm

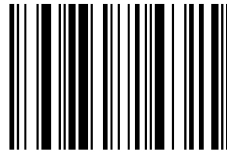

74 mm

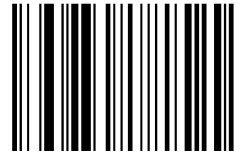

88 mm

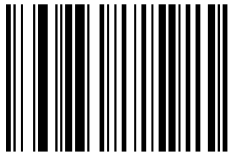

90 mm

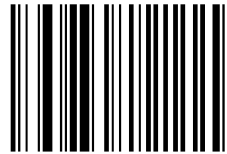

100 mm

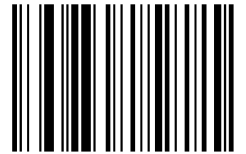

102 mm

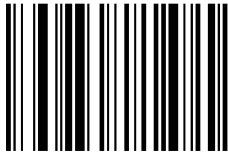

104 mm

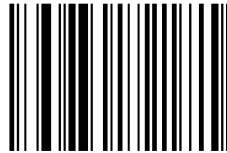

125 mm

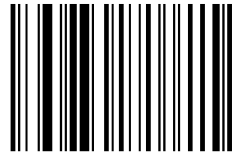

130 mm

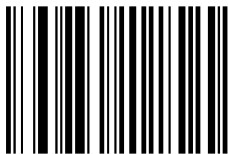

150 mm

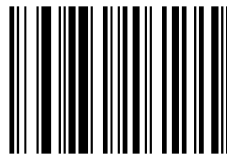

158 mm

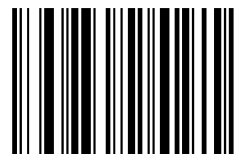

210 mm



## Media Type

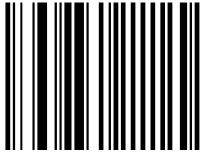

Label (w gaps)



Ticket (w mark)

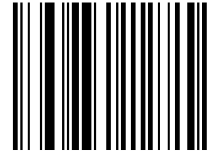

Ticket (w gaps)

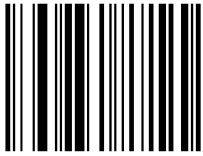

Fix Length Strip

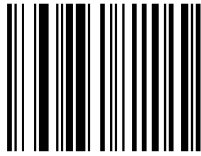

Var Length Strip

---

## Print Speed

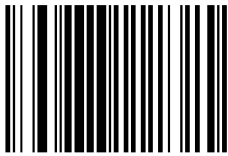

100 mm/sec

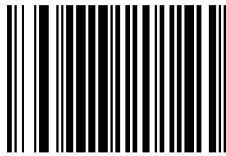

125 mm/sec

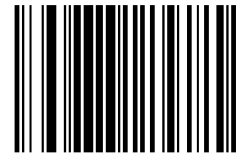

150 mm/sec



175 mm/sec

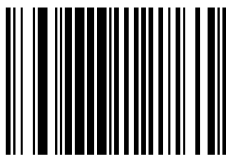

200 mm/sec

## Paper Type

### Direct Thermal Printing (Europe)

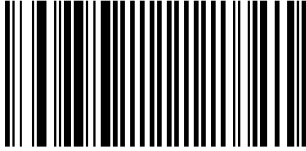

Top Board

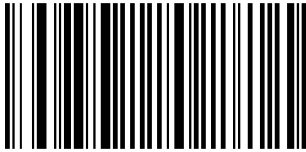

Economy

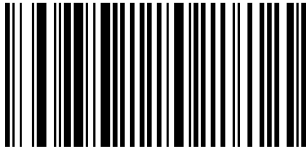

Premium High Speed

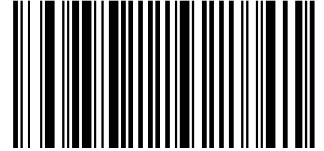

Standard/Premium

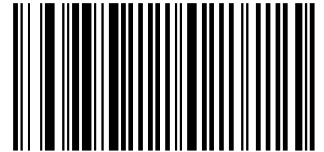

Eco Board

---

### Direct Thermal Printing (USA)

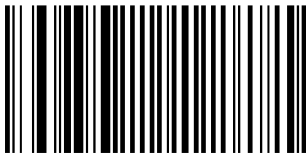

Duratherm II Tag

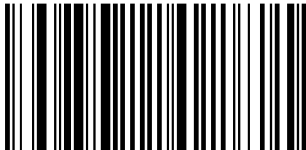

Duratherm Ltg

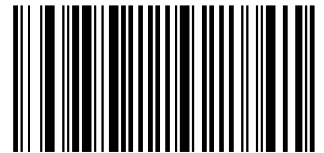

Duratherm II

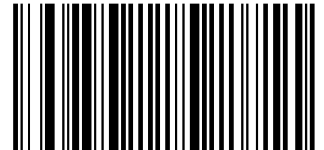

Duratherm IR

# RFID Module

The EasyCoder F4 can optionally be fitted with an Intellitag® 500 RFID (radio frequency identification) board that provides the printer with the means to pre-program Intellitag® 500 RFID SmartLabels when the bar code portion of the label is printed.

The RFID board is addressed in Intermec Fingerprint 7.3 or later as device “uart2:”

The RFID board does not require connection to any device external to the printer.

The RFID module is fitted in the printer in the space allocated for optional interface boards and therefore cannot be used in conjunction with, or in addition to, any of the optional interface boards.

Refer to the installation instructions for the RFID Option Board for further information.

