

Measurement Report

Product.....: ***External Data/Fax Modem With Voice***
Manufacture.....: ***Archtek Telecom Corporation***
FCC ID.....: ***F17MREF56***
Model.....: ***5634IF***
Report No......: ***MLT9806P15004***
Test Date.....: ***JUL,15.1998***

Test By

Max Light Technology Co.,Ltd.
Room 5, 8F, No.125, Section 3 Roosevelt Road,
Taipei, Taiwan., R.O.C.
Tel: 886-2-2363-2447 Fax: 886-2-2363-2597



MAX LIGHT
MEASUREMENT REPORT

Table of Contents :

I. General 4.

II. Conducted Emissions Requirements 9.

III. Radiated Emissions Requirements 13.

Appendix I (EUT Test Setup) 18.



MAX LIGHT
MEASUREMENT REPORT

Page: 3/19

CERTIFICATION

We here by verify that :

The test data, data evaluation, test procedures and equipment configurations shown in this report were made in accordance with the procedures given in ANSI C63.4-1992. All test were conducted by *MLT(Max Light Technology Co.,Ltd) Room 5, 8F, No.125, Section 3 Roosevelt Road, Taipei, Taiwan, R.O.C* Also, we attest to the accuracy of each.

We further submit that the energy emitted by the sample EUT tested as described in the report is in compliance with Class B radiated and conducted emission limit of FCC Rules Part 15 Subpart B.



EUT : External Data/Fax Modem With Voice

Applicant : Archtek Telecom Corporation .
4F. No.9, Lane 130, Min-Chyuan Rd.,
Hsin-Tien , Taipei ,Taiwan

Manufacturer : Archtek Telecom Corporation .
4F. No.9, Lane 130, Min-Chyuan Rd.,
Hsin-Tien , Taipei ,Taiwan

Model No : 5634IF

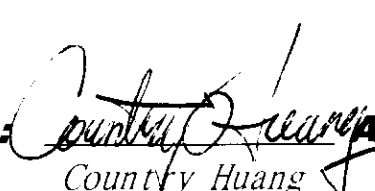
FCC ID : F17MREF56

Prepared by :  **Approved by :** 

Country Huang

Roger Chen

Report Number: MLT9806P15004

FCC ID: F17MREF56



MAX LIGHT

MEASUREMENT REPORT

Page: 4/19

I. GENERAL

1.1 Introduction

The following measurement report is submitted on behalf of Archtek Telecom Corporation. In support of a Glass B Digital Device certification in accordance with Part 2 Subpart J and Part 15 Subpart A And B of the Commission's and Regulations.

1.2 Description of EUT

EUT : External Data/Fax Modem With Voice

Applicant : Archtek Telecom Corporation .
4F. No.9, Lane 130, Min-Chyuan Rd.,
Hsin-Tien , Taipei , Taiwan

Manufacturer : Archtek Telecom Corporation .
4F. No.9, Lane 130, Min-Chyuan Rd.,
Hsin-Tien , Taipei , Taiwan

Model No : 5634IF

FCC ID : F17MREF56

Power Type : Powered by PC

Phone Cable : RJ-11Cx2(Nonshielded, 7' long ,Plastic hoods)

During testing the EUT was operated at Tx or Rx mode for each emission measured. This was done in order to ensure that maximum emission levels were attained.



MAX LIGHT

MEASUREMENT REPORT

Page: 5/19

1.3 Description of Support Equipment

In order to construct the minimum system which required by the ANSI C63.4-1991, following equipments were used as the support units.

Computer : COMPAQ
Model No. : 3284
Serial No. : L708BKTB4154
FCC ID : EJJH3284

Keyboard : COMPAQ
Model No. : KPQ-E99ZC-13
Serial No. : 237743-334
FCC ID : CMYKPQ7285

Monitor : COMPAQ
Model No. : 303U
Serial No. : 704AG19TG099
FCC ID : BJMCM14UH

Mouse : COMPAQ
Model No. : 285728-001
Serial No. : 97033491
FCC ID : FSUGMZE4

Printer : PANASONIC
Model No. : KX-P1080I
Serial No. : 7CKAKE98933
FCC ID : ACJ5Z6KX-P10801

PSTN Simulator : MLT
Model No. : 1101
Serial No. : N/A



MAX LIGHT
MEASUREMENT REPORT

Page: 6/19

Telephone : **GE**
Model No. : **2-9240A**
Serial No. : **1943K**

Speaker : **KAKA**
Model No. : **2K-A01**
Serial No. : **189665**

Microphone : **Ever Power**
Model No. : **TC-944**
Serial No. : **N/A**

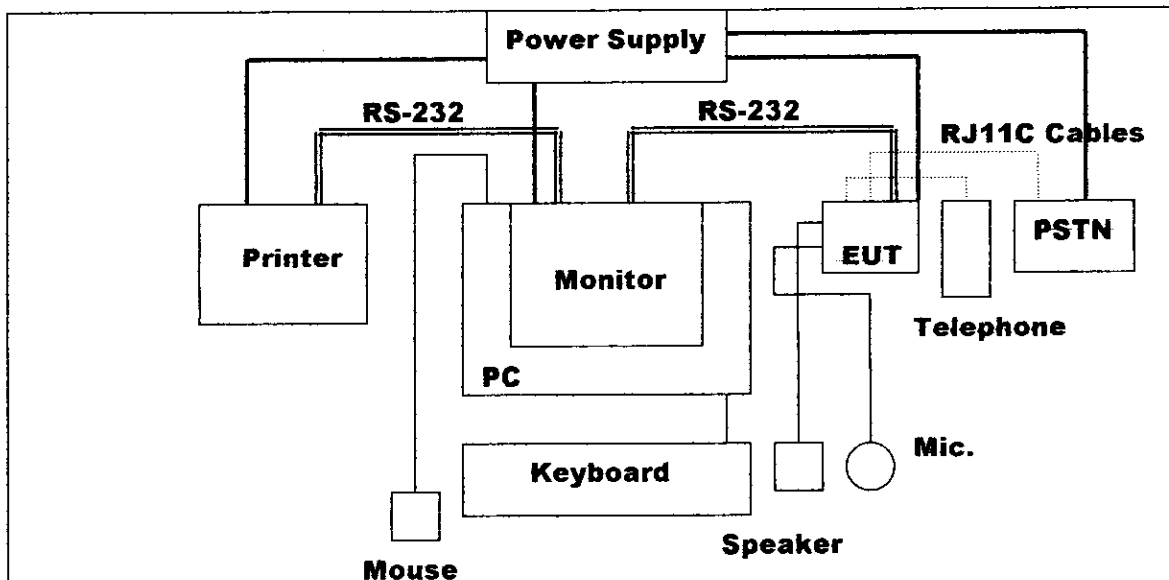
1.4 Configuration of System Under Test

During testing the EUT(External Data/Fax Modem with voice) was connected to the Compaq PC. So there is no need for additional I/O card. A mouse was connected to the mouse port and a printer was connected to the parallel port. A telephone set was connected to the Phone-Jack of EUT and the Line Jack of EUT was connected to a simulator of PSTN. And the Speaker Jack and Microphone Jack were connected with a small microphone and a external speaker.



MAX LIGHT

MEASUREMENT REPORT

Page: 8/19

1.5 Test Procedure

All measurements contained in this report were performed according to the techniques described in Measurement procedure ANSI C63.4-1992 "Measurement of unintentional Radiators."

1.6 General Test Condition

The conditions under which the EUT operates were varied to determine their effect on the equipment's emission characteristics. The final configuration of the test system and the mode of operation used during these tests was chosen as that which produced the highest emission levels. However, only those conditions which the EUT was considered likely to encounter in normal use were investigated. The system's radiated and conducted emissions were investigated while the computer alternately transferred data to the EUT as well as to the monitor and printer. Using a test program which sent a continuous stream of "H" characters to monitor and transferred data to and from the EUT was proven to worst case emissions. The system's physical layout and cabling was randomly arranged to ensure that maximum emission levels were attained.



II. Conducted Emissions Requirements

2.1 General & Setup :

The power line conducted emission measurements were performed in a shielded enclosure. The EUT was assembled on a wooden table which is 80 centimeters high, was placed 40 centimeters from the backwall and at least 1 meter from the sidewall.

Power was fed to the EUT from the public utility power grid through a line filter and EMCO Model 3825/2 Line Impedance Stabilization Networks (LISN). The LISN housing, measuring instrumentation case, ground plane, etc., were electrically bonded together at the same RF potential. The Spectrum analyzer was connected to the AC line through an isolation transformer. The 50-ohm output of the LISN was connected to the spectrum analyzer directly. Conducted emission levels were in the CISPER quasi-peak detection mode. The analyzer's 6 dB bandwidth was set to 9 KHz. No post-detector video filter was used.

The spectrum was scanned from 450 KHz to 30 MHz. The physical arrangement of the test system and associated cabling was varied (within the scope of arrangements likely to be encountered in actual use) to determine the effect on the unit's emanations in amplitude and frequency. All spurious emission frequencies were observed. The highest emission amplitudes relative to the appropriate limit were measured and have been recorded in paragraph 2.6.

2.2 Test Equipment List:

- A. EMCO 3825/2 LISN (S/N:2654)**
- B. EMCO 3825/2 LISN (S/N:2658)**
- C. HP 8591EM 9KHZ-1.8GHz Spectrum Analyzer (S/N:73412A00110)**
- D. Shielded Room (MLT-SR1)**



2.3 Test Configuration:



Front View of The Test Configuration

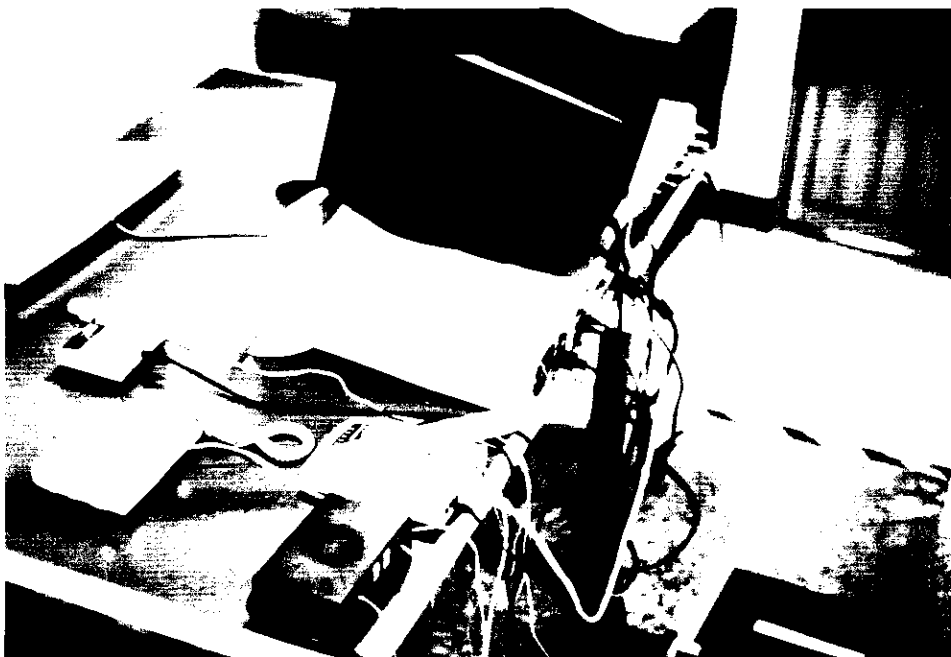

Rear View of The Test Configuration



MAX LIGHT
MEASUREMENT REPORT

2.4 Test condition:

EUT tested in accordance with the specifications given by the manufacturer , and exercised in the most unfavorable manner.

2.5 Conducted Emissions Limits:

<i>Frequency range (MHz)</i>	<i>Limits (dBuV)</i>
0.45 to 30	47.9



MAX LIGHT

MEASUREMENT REPORT

2.6 Measurement Data Of Conducted Emissions:

The following table show a summary of the highest emissions of power line conducted emissions to the HOT and NATURAL conductor of the EUT power.

Manufacturer : Archtek Telecom Corporation.
Model No : 5634IF
EUT : External Data/Fax Modem With Voice

Power Line Conducted Emissions (Class B)			
Conductor	Frequency (MHz)	Peak Amplitude (dBuV)	Limits (dBuV)
L1	0.45	33.58	47.9
	0.75	32.35	47.9
	9.63	42.53	47.9
	14.93	33.34	47.9
	15.67	37.28	47.9
	24.40	37.82	47.9
	30.00	32.58	47.9
L2	0.45	33.82	47.9
	0.75	30.16	47.9
	9.63	42.44	47.9
	14.93	35.82	47.9
	15.67	34.02	47.9
	24.40	38.06	47.9
	30.00	32.42	47.9

- Notes :**
- 1.L1: One end & Ground L2: The other end & Ground**
 - 2.Height of table on which the EUT was placed : 0.8 m.**
 - 3.The above test results are obtained under the normal condition.**



III. Radiated Emissions Requirements

3.1 General & Setup :

Prior to open-field testing, the EUT was placed in a shielded enclosure and scanned at a close distance to determine its emission characteristics. The physical arrangement of the EUT was varied (within the scope of arrangements likely to be encountered in actual use) to determine the effect on the unit's emanations in amplitude, directivity, and frequency. The exact system configuration which produced the highest emissions was noted so it could be reproduced later during the open-field tests. This was done to ensure that the final measurements would demonstrate the worst-case interference potential of the EUT. Final radiation measurements were made on a three-meter, open-field test site. The EUT system was placed on a nonconductive turntable which is 0.8 meters height, top surface 1.0 x 1.5 meter. The spectrum was examined from 30 MHz to 1000 MHz using an Hewlett Packard 8591EM Spectrum Analyzer, EMCO Biconical Antenna (Model 3142) for 30-1000MHz. At each frequency, the EUT was rotated 360 degrees, and the antenna was raised and lowered from one to four meters to find the maximum emission levels. Measurements were taken using both horizontal and vertical antenna polarization. Appropriate preamplifiers were used for improving sensitivity and precautions were taken to avoid overloading or desensitizing the spectrum analyzer. No post-detector video filters were used in the test. The spectrum analyzer's 6 dB bandwidth was set to 120 KHz, and the analyzer was operated in the quasi-peak detection mode. The highest emission amplitudes relative to the appropriate limit were measured and recorded in paragraph 3.6.

3.2 Test Equipment List:

- A. HP 8591EM 9KHz-1.8GHz Spectrum Analyzer (S/N:73412A00230)**
- B. HP 8447D Pre Amplifier (S/N:2944A08954)**
- C. EMCO 3142 Biconilog Antenna (S/N:1184)**
- D. HP 8590A 10KHz-1.5GHz Spectrum Analyzer (S/N:5212A000211)**



MAX LIGHT
MEASUREMENT REPORT

3.4 Test condition:

EUT tested in accordance with the specifications given by the manufacturer , and exercised in the most unfavorable manner.

3.5 Radiated Emissions Limits:

<i>Frequency range (MHz)</i>	<i>Peak(dBuV)</i>
30 to 88	40
88 to 216	43.5
216 to 960	46
Above 960	54



MAX LIGHT
MEASUREMENT REPORT

3.6 Measurement Data Of Radiated Emissions:

3.6.1 Open Field Radiated Emissions (HORIZONTAL)

The highest peak values of radiated emissions from the EUT at various antenna heights, antenna polarization, EUT orientation , etc. are recorded on the following

Manufacturer : Archtek Telecom Corporation
Model No : 5634IF
EUT : External Data/Fax Modem With Voice

Radiated Emissions (HORIZONTAL)					
Frequency (MHz)	Amplitude (dBuV/m)	Ant. (m)	Table (Degree)	Limits(Class B) (dBuV/m)	Margin (dB)
56.44	34.52	1	300	40	-5.48
141.14	37.32	2.5	300	43.5	-6.18
169.36	37.45	2.5	270	43.5	-6.05
225.80	39.13	2	300	46	-6.87
254.04	41.51	2	270	46	-4.49
310.48	40.42	2.5	360	46	-5.58
338.71	41.11	2.5	300	46	-4.89
366.93	40.38	2.5	360	46	-5.62
395.16	39.99	2	200	46	-6.01
423.38	41.48	1.5	360	46	-4.52
451.60	40.07	1.5	360	46	-5.93

- Notes :**
- 1.Margin= Amplitude - Limits**
 - 2.Distance of Measurement : 3 Meter (30-1000MHz)**
 - 3.Height of table for EUT placed: 0.8 Meter.**
 - 4.ANT= Antenna height.**
 - 5.Amplitude= Reading Amplitude -Amplifier gain+Cable loss +Antenna factor**
(Auto calculate in spectrum analyzer)



MAX LIGHT MEASUREMENT REPORT

3.6.2 Open Field Radiated Emissions (VERTICAL)

The highest peak values of radiated emissions from the EUT at various antenna heights, antenna polarization, EUT orientation , etc. are recorded on the following.

Manufacturer : Archtek Telecom Corporation.
Model No : 5634IF
EUT : External Data/Fax Modem With Voice

Radiated Emissions (VERTICAL)					
Frequency (MHz)	Amplitude (dBuV/m)	Ant. (m)	Table (Degree)	Limits(Class B) (dBuV/m)	Margin (dB)
56.44	35.45	1.5	360	40	-4.55
141.14	38.43	1.5	300	43.5	-5.07
169.36	40.39	1	300	43.5	-3.11
225.80	39.50	1	270	46	-6.50
254.04	38.44	1	300	46	-7.56
310.48	39.51	1	300	46	-6.49
338.71	41.42	1.5	360	46	-4.58
366.93	40.50	1.5	0	46	-5.50
395.16	39.42	1.5	270	46	-6.58
423.38	40.12	1	360	46	-5.88
451.60	39.50	1	360	46	-6.50

- Notes :**
- 1.Margin= Amplitude - Limits
 - 2.Distance of Measurement : 3 Meter (30-1000MHz)
 - 3.Height of table for EUT placed: 0.8 Meter.
 - 4.ANT= Antenna height.
 - 5.Amplitude= Reading Amplitude - Amplifier gain + Cable loss + Antenna factor
(Auto calculate in spectrum analyzer)



Appendix I- EUT Test SETUP

MEASUREMENT OF POWER LINE CONDUCTED RFI VOLTAGE

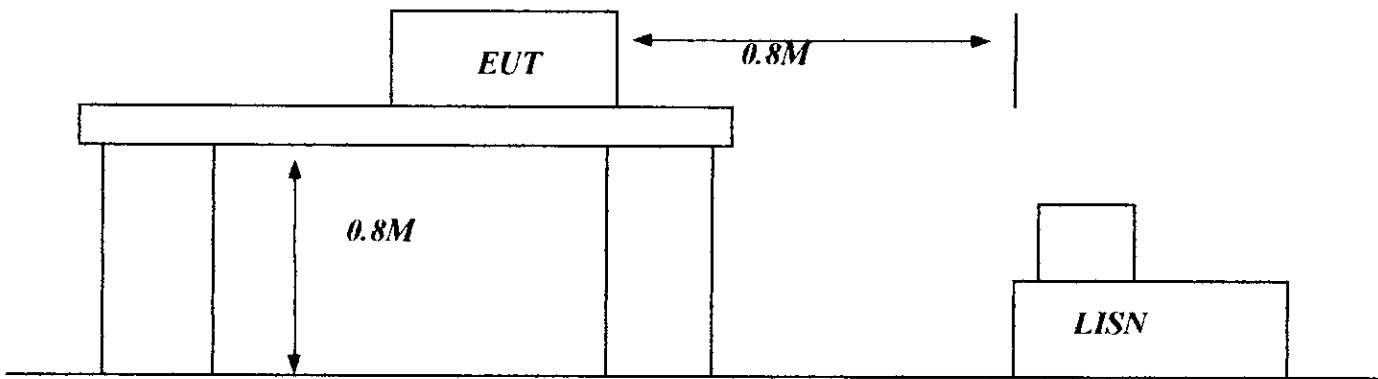

Metal floor surfaced with 30mm of insulating material



Appendix I- EUT Test SETUP

MEASUREMENT OF RADIATED EMISSION

