

# ***Measurement Report***

***Product*** .....: ***External 56K Data/Fax Modem***  
***Manufacture*** .....: ***Archtek Telecom Corporation***  
***FCC ID*** .....: ***FI7MIEV56***  
***Model*** .....: ***56TPC***  
***Report No.*** .....: ***MLT0111P15001***  
***Test Date*** .....: ***November 2.2001***

***Test By***

**Max Light Technology Co.,Ltd.**

*Room 5, 8F, No.125, Section 3 Roosevelt Road,  
Taipei, Taiwan., R.O.C.*

Tel: 886-2-2363-2447 Fax: 886-2-2363-2597

**The test report consists of 1 pages in total. It may be duplicated completely for legal use with the allowance of the applicant. It shall not be reproduced except in full, without the written approval of our laboratory.**



# **MAX LIGHT**

## **MEASUREMENT REPORT**

### **Table of Contents :**

<b><i>I. General</i></b> .....	<b>4</b>
<b><i>II. Conducted Emissions Requirements</i></b> .....	<b>9</b>
<b><i>III. Radiated Emissions Requirements</i></b> .....	<b>13</b>
<b><i>Appendix I (EUT Test Setup)</i></b> .....	<b>18</b>



## CERTIFICATION

***We here by verify that :***

The test data, data evaluation, test procedures and equipment configurations shown in this report were made in accordance with the procedures given in ANSI C63.4-1992. All test were conducted by *MLT(Max Light Technology Co.,Ltd) Room 5, 8F, No.125, Section 3 Roosevelt Road, Taipei, Taiwan, R.O.C* Also, we attest to the accuracy of each.

We further submit that the energy emitted by the sample EUT tested as described in the report is in compliance with Class B radiated and conducted emission limit of FCC Rules Part 15 Subpart B.

EUT : External 56K Data/Fax Modem

Applicant : Archtek Telecom Corporation .  
10F, NO. 110, SEC3, CHUNG-SHAN ROAD.,  
CHUNG-HO, TAIPEI, 231 TAIWAN, R.O.C.

Manufacturer : Archtek Telecom Corporation .  
4F. No.9, Lane 130, Min-Chyuan Rd.,  
Hsin-Tien , Taipei ,Taiwan

Model No : 56TPC

FCC ID : FI7MIEV56

Prepared by : *Country Huang* Approved by : *Roger Chen.*  
*Country Huang* *Roger Chen*



## **I. GENERAL**

### 1.1 Introduction

The following measurement report is submitted on behalf of Archtek Telecom Corporation. In support of a Class B Digital Device certification in accordance with Part2 Subpart J and Part 15 Subpart A And B of the Commission's and Regulations.

### 1.2 Description of EUT

EUT : External 56K Data/Fax Modem

Applicant : Archtek Telecom Corporation .  
4F. No.9, Lane 130, Min-Chyuan Rd.,  
Hsin-Tien , Taipei ,Taiwan

Manufacturer : Archtek Telecom Corporation .  
4F. No.9, Lane 130, Min-Chyuan Rd.,  
Hsin-Tien , Taipei ,Taiwan

Model No : 56TPC

FCC ID : FI7MIEV56

Power Type : Powered by AC Adaptor (9V AC,1.0A)

Phone Cable : RJ-11Cx2(Nonshielded, 7' long ,Plastic hoods)

RS-232 Cable (9Pin) : RS-232 (9Pin) Connector x1(Shielded, 80cm long )

During testing the EUT was operated at Tx or Rx mode for each emission measured. This was done in order to ensure that maximum emission levels were attained.



### 1.3 Description of Support Equipment

In order to construct the minimum system which required by the ANSI C63.4-1991, following equipments were used as the support units.

*Computer* : IBM  
Model No. : 16W  
Serial No. : BNC345M  
FCC ID : FCC DOC

*Keyboard* : IBM  
Model No. : KB-9930  
Serial No. : 09N5395  
FCC ID : FCC DOC

*Monitor* : IBM  
Model No. : 10L6145 030  
Serial No. : 23-092079  
FCC ID :

*Mouse* : IBM  
Model No. : 0180-05N  
Serial No. : 23-96142  
FCC ID : EMJMUSJJ

*Printer* : PANASONIC  
Model No. : KX-P1080I  
Serial No. : 7CKAKE98933  
FCC ID : ACJ5Z6KX-P10801



**MAX LIGHT**  
MEASUREMENT REPORT

Page: 6/21

Telephone : GE  
Model No. : 2-9240A  
Serial No. : 1943K

### 1.4 Configuration of System Under Test

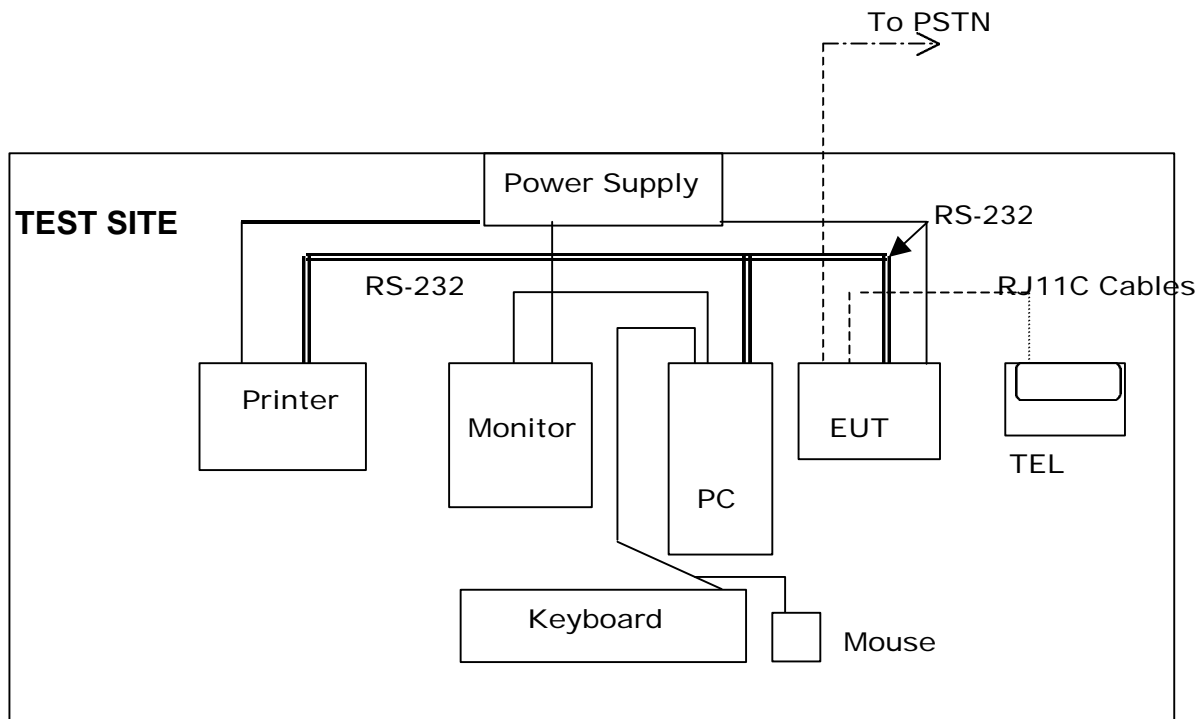

During testing the EUT(External 56K Data/Fax Modem ) was connected to the IBM PC's RS-232 port. So there is no need for additional I/O card. A mouse was connected to the mouse port and a printer was connected to the parallel port. A telephone set was connected to the Phone Jack of EUT and the Line Jack of EUT was connected to a simulator of PSTN.



## 1.5 Test Procedure

All measurements contained in this report were performed according to the techniques described in Measurement procedure ANSI C63.4-1992 "Measurement of unIntentional Radiators."

## 1.6 General Test Condition

The conditions under which the EUT operates were varied to determine their effect on the equipment's emission characteristics. The final configuration of the test system and the mode of operation used during these tests was chosen as that which produced the highest emission levels. However, only those conditions which the EUT was considered likely to encounter in normal use were investigated. The system's radiated and conducted emissions were investigated while the computer alternately transferred data to the EUT as well as to the monitor and printer. Using a test program which sent a continuous stream of "H" characters to monitor and transferred data to and from the EUT was proven to worst case emissions. The system's physical layout and cabling was randomly arranged to ensure that maximum emission levels were attained.





## ***II. Conducted Emissions Requirements***

### 2.1 General & Setup :

The power line conducted emission measurements were performed in a shielded enclosure. The EUT was assembled on a wooden table which is 80 centimeters high, was placed 40 centimeters from the backwall and at least 1 meter from the sidewall.

Power was fed to the EUT from the public utility power grid through a line filter and EMCO Model 3825/2 Line Impedance Stabilization Networks (LISN). The LISN housing, measuring instrumentation case, ground plane, etc., were electrically bonded together at the same RF potential. The Spectrum analyzer was connected to the AC line through an isolation transformer. The 50-ohm output of the LISN was connected to the spectrum analyzer directly. Conducted emission levels were in the CISPER quasi-peak detection mode. The analyzer's 6 dB bandwidth was set to 9 KHz. No post-detector video filter was used.

The spectrum was scanned from 450 KHz to 30 MHz. The physical arrangement of the test system and associated cabling was varied (within the scope of arrangements likely to be encountered in actual use) to determine the effect on the unit's emanations in amplitude and frequency. All spurious emission frequencies were observed. The highest emission amplitudes relative to the appropriate limit were measured and have been recorded in paragraph 2.6.

### 2.2 Test Equipment List:

- A. EMCO 3825/2 LISN (S/N:2654)
- B. EMCO 3825/2 LISN (S/N:2658)
- C. HP 8591EM 9KHZ-1.8GHz Spectrum Analyzer (S/N:73412A00110)
- D. Shielded Room (MLT-SR1)



# **MAX LIGHT**

## MEASUREMENT REPORT

### 2.4 Test condition:

EUT tested in accordance with the specifications given by the manufacturer , and exercised in the most unfavorable manner.

### 2.5 Conducted Emissions Limits:

<i>Frequency range (MHz)</i>	<i>Limits (dBuV)</i>
0.45 to 30	47.9



# MAX LIGHT

## MEASUREMENT REPORT

### 2.6 Measurement Data Of Conducted Emissions:

The following table show a summary of the highest emissions of power line conducted emissions to the HOT and NATURAL conductor of the EUT power.

Manufacturer : Archtek Telecom Corporation.  
 Model No : 56TPC  
 EUT : External 56K Data/Fax Modem

Power Line Conducted Emissions (Class B)			
Conductor	Frequency (MHz)	Peak Amplitude (dBuV)	Limits (dBuV)
L1	0.17	43.76	47.9
	0.22	41.87	47.9
	0.76	43.25	47.9
	4.58	38.76	47.9
	8.91	40.98	47.9
	12.34	38.13	47.9
	25.67	35.45	47.9
L2	0.17	41.76	47.9
	0.22	38.64	47.9
	0.76	42.92	47.9
	4.58	39.89	47.9
	8.91	41.21	47.9
	12.34	39.74	47.9
	25.67	32.17	47.9

- Notes :
- 1.L1: One end & Ground L2: The other end & Ground
  - 2.Height of table on which the EUT was placed : 0.8 m.
  - 3.The above test results are obtained under the normal condition.



### ***III. Radiated Emissions Requirements***

#### 3.1 General & Setup :

Prior to open-field testing, the EUT was placed in a shielded enclosure and scanned at a close distance to determine its emission characteristics. The physical arrangement of the EUT was varied (within the scope of arrangements likely to be encountered in actual use) to determine the effect on the unit's emanations in amplitude, directivity, and frequency. The exact system configuration which produced the highest emissions was noted so it could be reproduced later during the open-field tests. This was done to ensure that the final measurements would demonstrate the worst-case interference potential of the EUT. Final radiation measurements were made on a three-meter, open-field test site. The EUT system was placed on a nonconductive turntable which is 0.8 meters height, top surface 1.0 x 1.5 meter. The spectrum was examined from 30 MHz to 1000 MHz using an Hewlett Packard 8591EM Spectrum Analyzer, EMCO Biconical Antenna (Model 3142) for 30-1000MHz. At each frequency, the EUT was rotated 360 degrees, and the antenna was raised and lowered from one to four meters to find the maximum emission levels. Measurements were taken using both horizontal and vertical antenna polarization. Appropriate preamplifiers were used for improving sensitivity and precautions were taken to avoid overloading or desensitizing the spectrum analyzer. No post-detector video filters were used in the test. The spectrum analyzer's 6 dB bandwidth was set to 120 KHz, and the analyzer was operated in the quasi-peak detection mode. The highest emission amplitudes relative to the appropriate limit were measured and recorded in paragraph 3.6.

#### 3.2 Test Equipment List:

- A. HP 8591EM 9KHz-1.8GHz Spectrum Analyzer (S/N:73412A00230)
- B. HP 8447D Pre Amplifier (S/N:2944A08954)
- C. EMCO 3142 Biconilog Antenna (S/N:1184)
- D. HP 8590A 10KHz-1.5GHz Spectrum Analyzer (S/N:5212A000211)



# **MAX LIGHT**

## MEASUREMENT REPORT

### 3.4 Test condition:

EUT tested in accordance with the specifications given by the manufacturer , and exercised in the most unfavorable manner.

### 3.5 Radiated Emissions Limits:

<i>Frequency range (MHz)</i>	<i>Peak(dBuV)</i>
30 to 88	40
88 to 216	43.5
216 to 960	46
Above 960	54



# MAX LIGHT

## MEASUREMENT REPORT

### 3.6 Measurement Data Of Radiated Emissions:

#### 3.6.1 Open Field Radiated Emissions (HORIZONTAL)

The highest peak values of radiated emissions from the EUT at various antenna heights, antenna polarization, EUT orientation , etc. are recorded on the following

Manufacturer : Archtek Telecom Corporation.  
Model No : 56TPC  
EUT : External 56K Data/Fax Modem

Radiated Emissions (HORIZONTAL)					
Frequency (MHz)	Amplitude (dBuV/m)	Ant. (m)	Table (Degree)	Limits(Class B) (dBuV/m)	Margin (dB)
55.30	32.85	1	360	40	-7.15
77.52	33.78	2	180	40	-6.22
110.66	35.43	1	210	43.5	-8.07
121.66	36.87	2.5	250	43.5	-6.63
184.41	38.65	1	100	43.5	-4.85
192.02	37.89	1.5	270	43.5	-5.61
210.56	39.16	2	190	43.5	-4.34
223.82	38.03	1.5	360	46	-7.97
331.54	44.46	1.5	300	46	-1.54
405.68	43.23	2	240	46	-2.77
663.57	43.44	1.5	360	46	-2.56

- Notes :
- 1.Margin= Amplitude - Limits
  - 2.Distance of Measurement : 3 Meter (30-1000MHz)
  - 3.Height of table for EUT placed: 0.8 Meter.
  - 4.ANT= Antenna height.
  - 5.Amplitude= Reading Amplitude -Amplifier gain+Cable loss +Antenna factor  
(Auto calculate in spectrum analyzer)



# MAX LIGHT

## MEASUREMENT REPORT

### 3.6.2 Open Field Radiated Emissions (VERTICAL)

The highest peak values of radiated emissions from the EUT at various antenna heights, antenna polarization, EUT orientation , etc. are recorded on the following.

Manufacturer : Archtek Telecom Corporation.  
Model No : 56TPC  
EUT : External 56K Data/Fax Modem

Radiated Emissions (VERTICAL)					
Frequency (MHz)	Amplitude (dBuV/m)	Ant. (m)	Table (Degree)	Limits(Class B) (dBuV/m)	Margin (dB)
55.30	35.78	1	300	40	-4.22
77.42	37.31	1.5	210	40	-2.69
110.59	36.23	1	300	43.5	-7.27
121.66	38.98	1	360	43.5	-4.52
184.32	39.99	1.5	180	43.5	-3.51
197.50	38.12	1	360	43.5	-5.38
210.13	38.77	2	100	43.5	-4.73
229.08	38.62	1	170	46	-7.38
331.78	44.17	1.5	360	46	-1.83
405.51	44.76	1	100	46	-1.24
479.22	43.87	1.5	300	46	-2.13

- Notes :
- 1.Margin= Amplitude - Limits
  - 2.Distance of Measurement : 3 Meter (30-1000MHz)
  - 3.Height of table for EUT placed: 0.8 Meter.
  - 4.ANT= Antenna height.
  - 5.Amplitude= Reading Amplitude -Amplifier gain+Cable loss +Antenna factor  
(Auto calculate in spectrum analyzer)

**Appendix I- EUT Test SETUP**

MEASUREMENT OF POWER LINE CONDUCTED RFI VOLTAGE

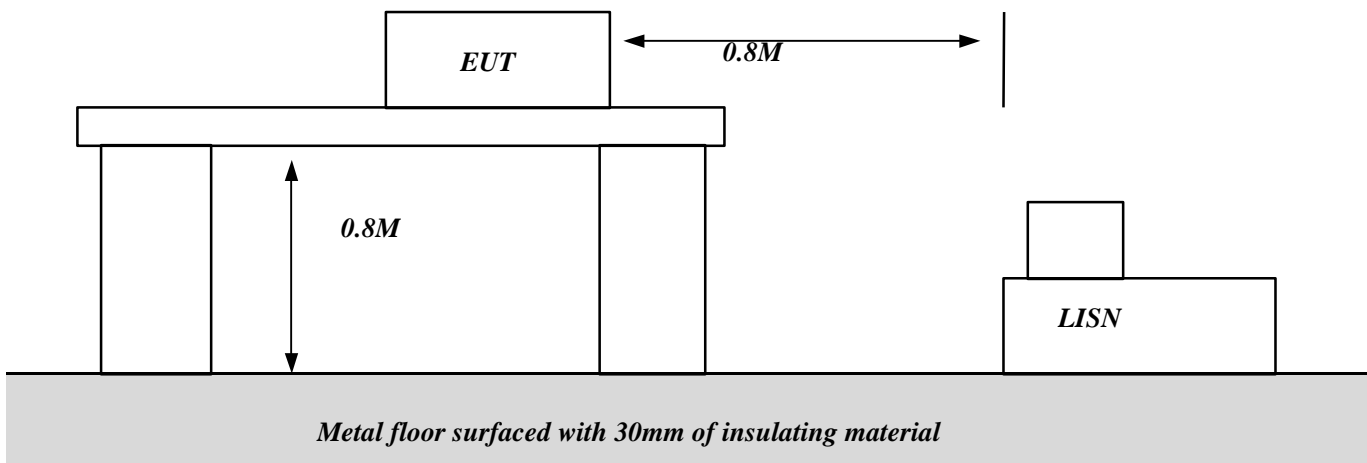



**Appendix I- EUT Test SETUP**

MEASUREMENT OF RADIATED EMISSION

