

HAVSDUN

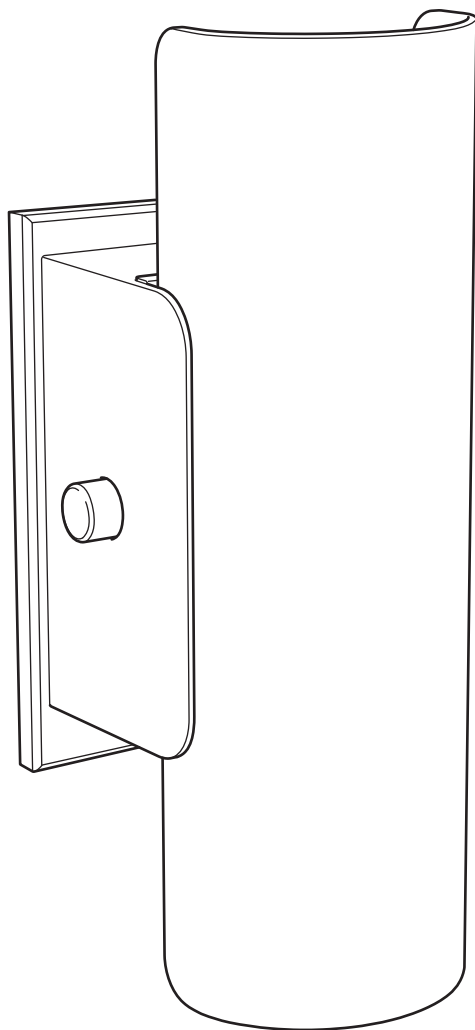

Design and Quality
IKEA of Sweden



English

INSTALLATION INSTRUCTIONS

CAUTION:

Before starting, turn off power at main circuit panel.

English

CAUTION!

The light source of this product is non-changeable light diodes (LED). Do not disassemble the product, as the light diodes can cause damage to the eyes.
Do not immerse in water

English

This device complies with part 15 of the FCC Rules. Operation is subjected to the following two conditions:

1. This device may not cause harmful interference, and
2. this device must accept any interference received, including interference that may cause undesired operation.

WARNING

Changes or modifications not expressly approved by the party responsible for compliance could void the user's authority to operate the equipment.

Français

INSTRUCTIONS D'INSTALLATION

ATTENTION:

coupez l'alimentation avant de procéder à l'installation.

Français

ATTENTION!

La source lumineuse de ce produit se compose de diodes électroluminescentes non remplaçables (LED).
Ne pas démonter le produit car les diodes électroluminescentes peuvent abîmer les yeux.
Ne pas plonger dans l'eau.

Français

Cet appareil est conforme à la partie 15 des règles de la FCC. Son fonctionnement est soumis aux deux conditions suivantes:

1. Cet appareil ne doit pas provoquer de brouillage préjudiciable et
2. il doit accepter tout brouillage reçu, y compris le brouillage pouvant entraîner un mauvais fonctionnement.

ATTENTION:

Tout changement apporté à cet appareil non expressément approuvé par la partie responsable de la conformité est susceptible d'annuler le droit de l'utilisateur à se servir de cet équipement.



Español

INSTRUCCIONES DE MONTAJE

ADVERTENCIA:

Antes de comenzar el montaje, cortar la luz en el cuadro general.

Español

¡ADVERTENCIA!

La fuente luminosa de este producto es un diodo de emisión de luz (LED) que no se puede sustituir.

No desmontes el producto, porque los diodos pueden dañar la vista.

No lo sumerjas en agua.

Español

Este aparato cumple la parte 15 de las normas FCC. Su funcionamiento está sujeto a las dos condiciones siguientes:

1. Este aparato no debe provocar interferencias perjudiciales.
2. Debe aceptar cualquier interferencia que reciba, incluidas las interferencias que puedan suponer un mal funcionamiento.

ATENCIÓN:

Cualquier cambio o modificación que se realice sin ser aprobado expresamente por la parte responsable de la conformidad, es susceptible de anular el derecho del usuario a utilizar este equipo.

MX

Importador/Distribuidor: IKEA Supply Mexico, S.A. de C.V., Av. Paseo de las Palmas 275, Int. 403-404, Lomas de Chapultepec V sección, Miguel Hidalgo C.P.: 11000 Ciudad de México, México, Tel. 800-1-4532 69.

Lea y siga todas las instrucciones de seguridad y operación antes de usar este producto/Para uso Interior/Consulte Especificaciones eléctricas en el etiquetado del producto.

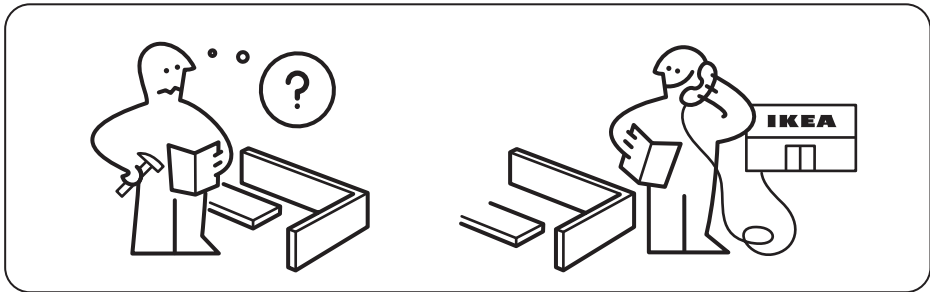
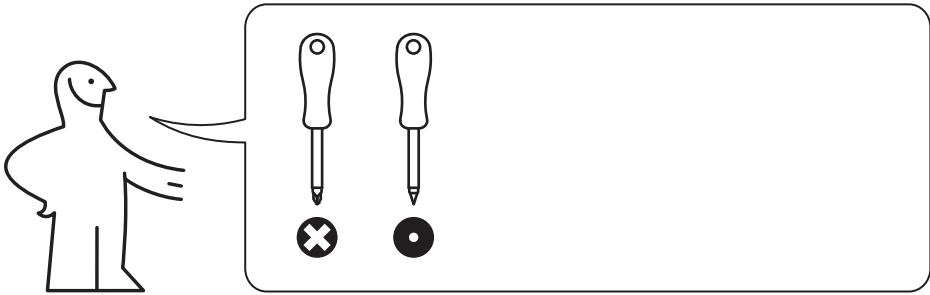

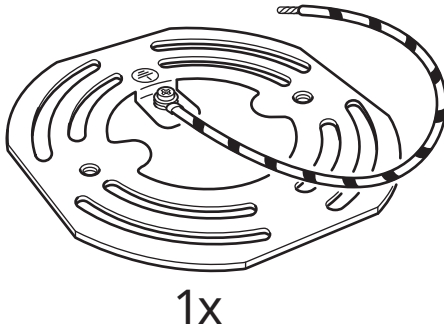
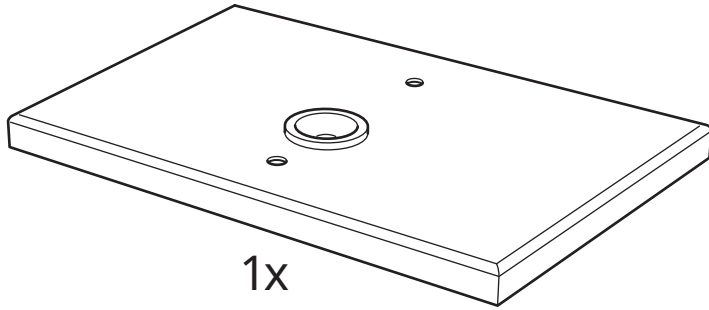

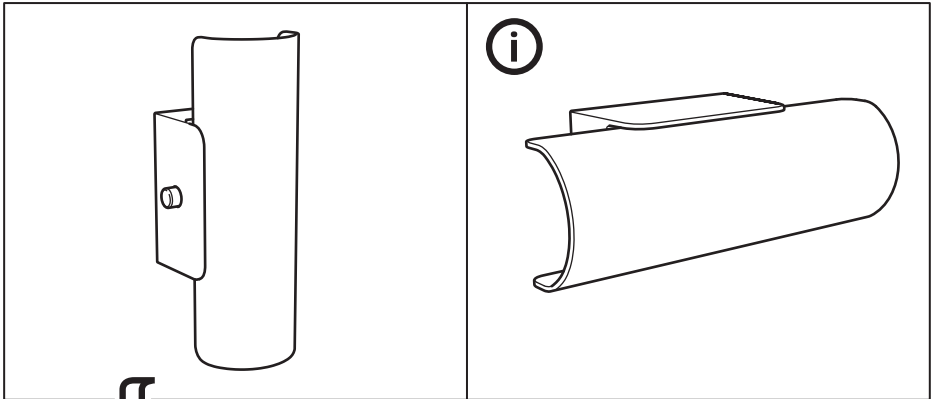

1

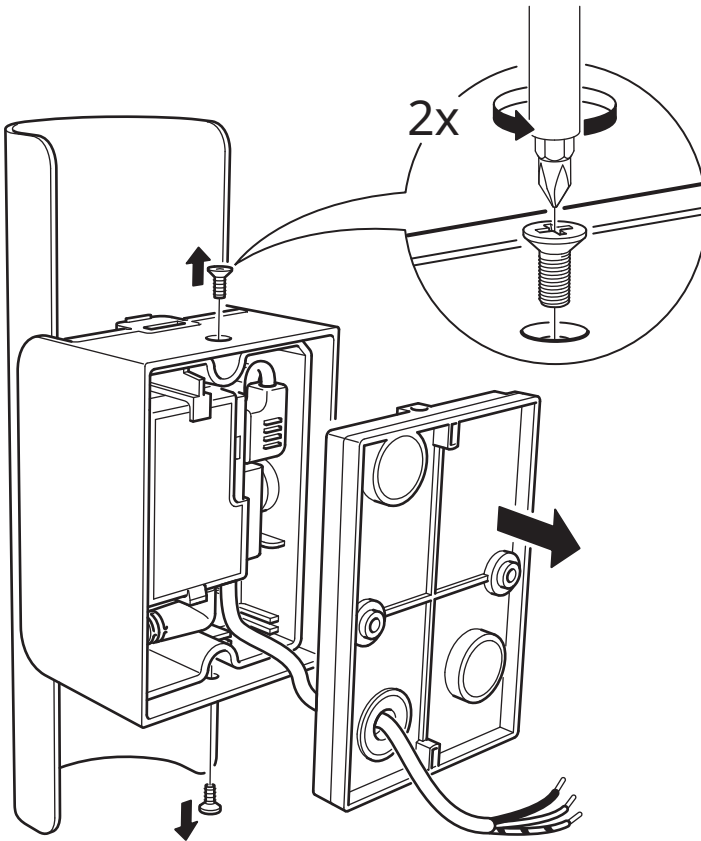

2

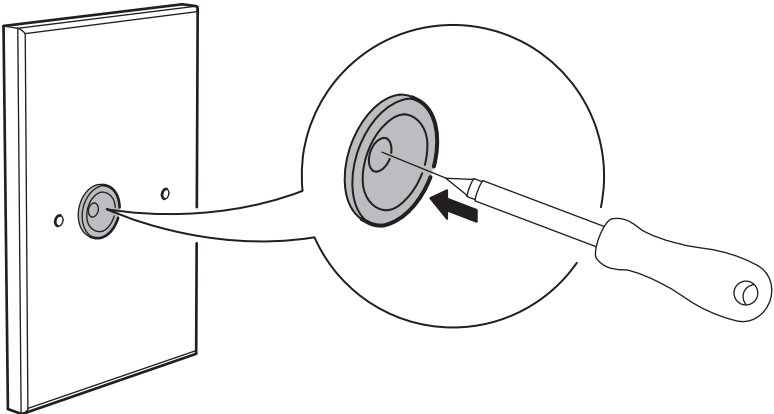

3

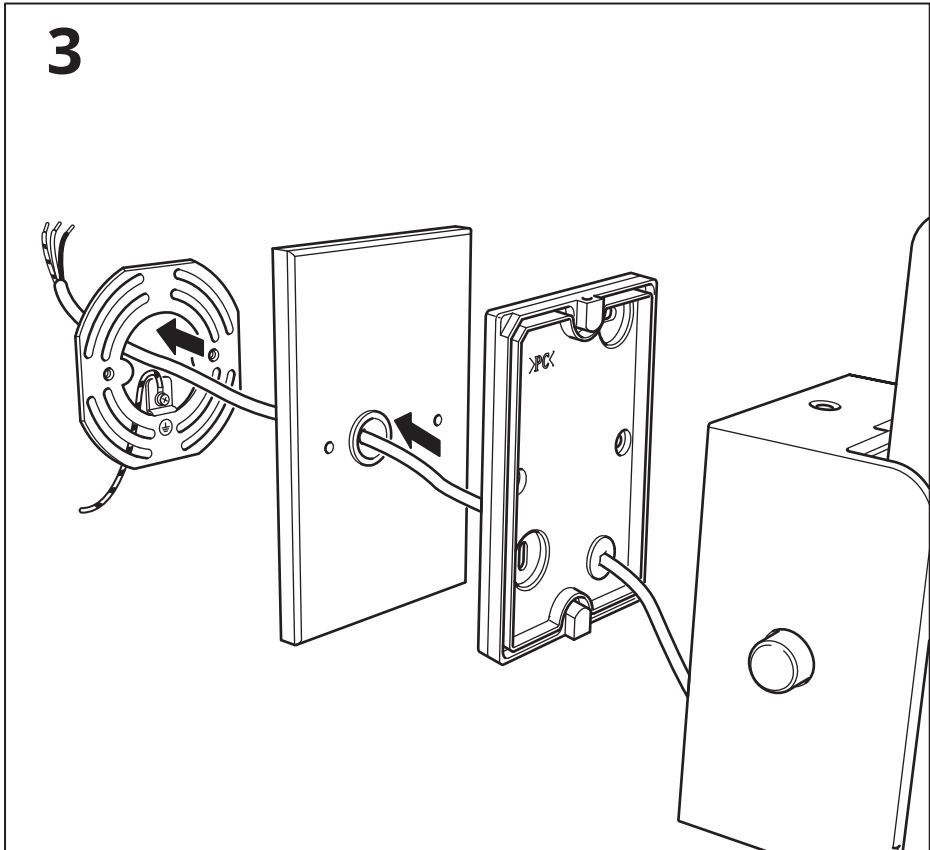

4



English
Live

Français
Phase

Español
Con corriente.

English
Neutral

Français
Neutre

Español
Neutro

English
Earth/
Ground

Français
Terre

Español
Tierra

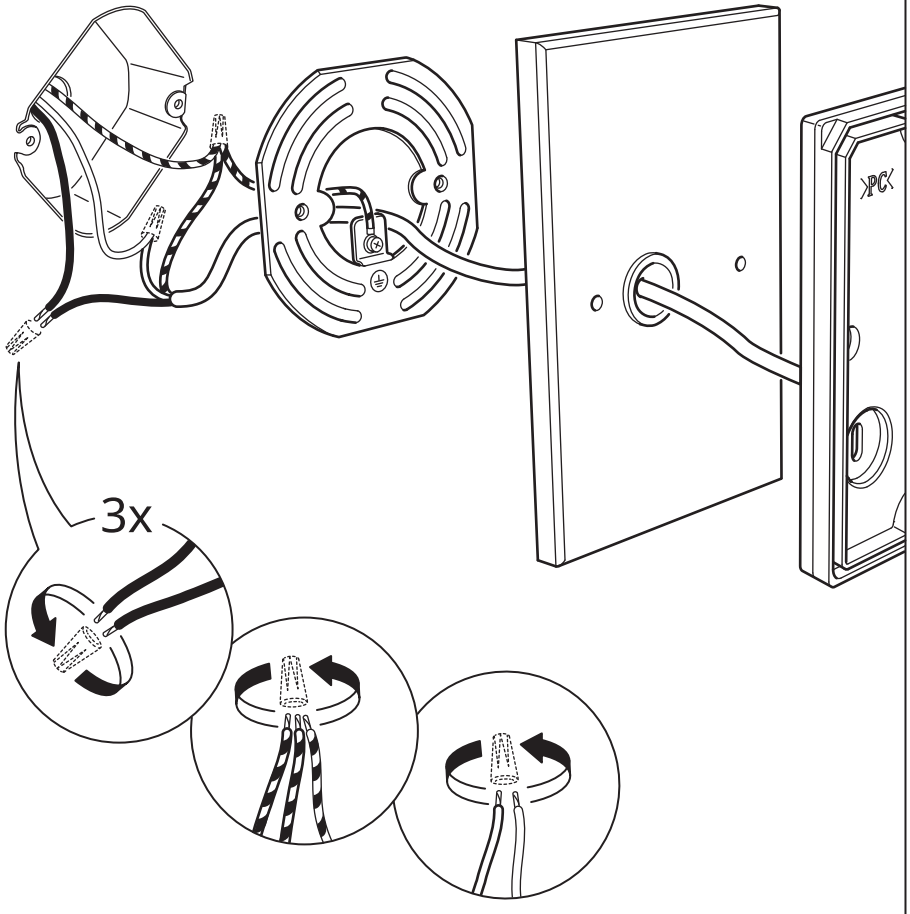

5

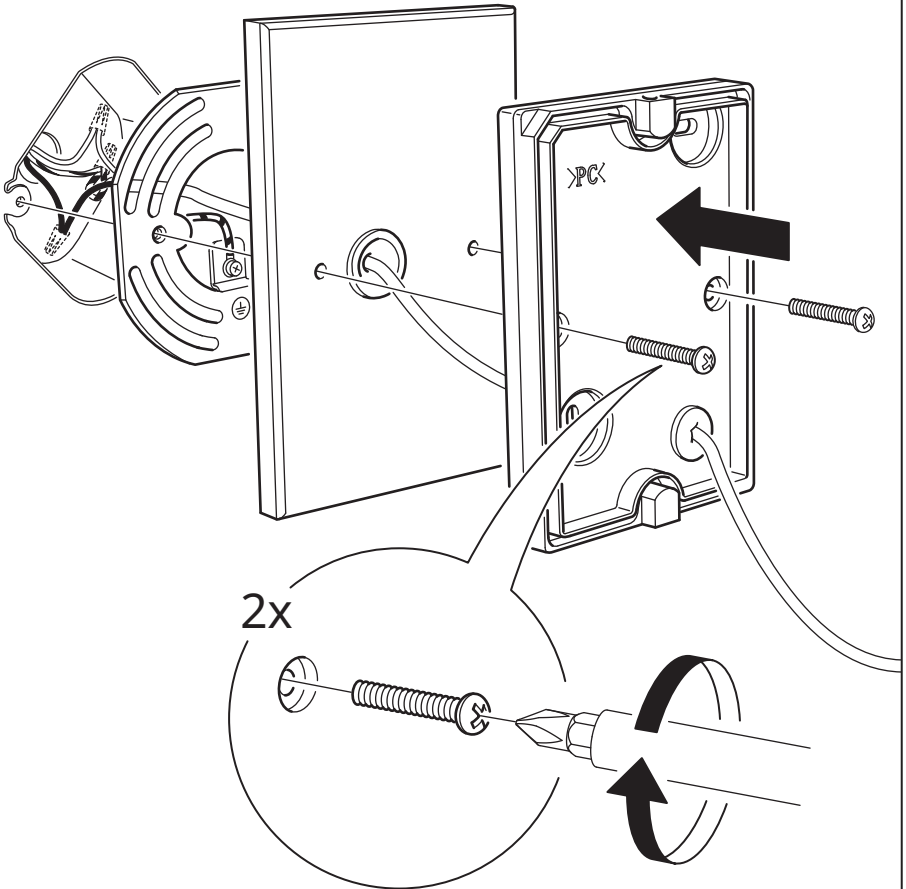
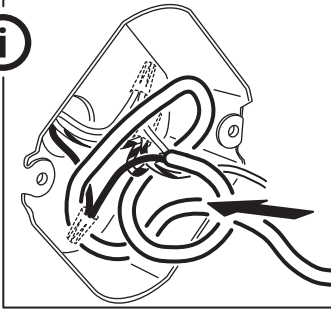

6

