

IKEA of Sweden AB

TEST REPORT

SCOPE OF WORK:

FCC Part 15 subpart B – EMC report

Model:

LED2219G3

REPORT NUMBER

220900941SHA-001

ISSUE DATE

November 23,2022

DOCUMENT CONTROL NUMBER

TTRFFCCPART15b_V1

© 2018 Intertek



Applicant : **IKEA of Sweden AB**
Box 702, SE-343 81 Älmhult, SWEDEN

Manufacturer : **LEEDARSON LIGHTING CO., LTD.**
Xingtai Industrial Park, Economic Development Zone of Changtai
County, Zhangzhou City, Fujian Province, China

FCC ID: FHO-LED2219G3

Summary

The equipment complies with the requirements according to the following standard(s) or Specification:

47CFR Part 15 (2020): Radio Frequency Devices (Subpart B)

ANSI C63.4 (2014): American National Standard for Methods of Measurement of Radio-Noise Emissions from Low-Voltage Electrical and Electronic Equipment in the Range of 9 kHz to 40 GHz

PREPARED BY: **REVIEWED BY:**

Star Guo *Star Guo*
Project Engineer

Andy Chen *Andy Chen*
Reviewer

This report is for the exclusive use of Intertek's Client and is provided pursuant to the agreement between Intertek and its Client. Intertek's responsibility and liability are limited to the terms and conditions of the agreement. Intertek assumes no liability to any party, other than to the Client in accordance with the agreement, for any loss, expense or damage occasioned by the use of this report. Only the Client is authorized to permit copying or distribution of this report and then only in its entirety. Any use of the Intertek name or one of its marks for the sale or advertisement of the tested material, product or service must first be approved in writing by Intertek. The observations and test results in this report are relevant only to the sample tested. This report by itself does not imply that the material, product, or service is or has ever been under an Intertek certification program.

Contents

REVISION HISTORY	4
MEASUREMENT RESULT SUMMARY	5
1 GENERAL INFORMATION	6
1.1 DESCRIPTION OF EQUIPMENT UNDER TEST (EUT)	6
1.2 DESCRIPTION OF TEST FACILITY	7
2 TEST SPECIFICATIONS	8
2.1 STANDARDS OR SPECIFICATION	8
2.2 MODE OF OPERATION DURING THE TEST.....	8
2.3 TEST SOFTWARE LIST	8
2.4 TEST PERIPHERALS LIST	8
2.5 RECORD OF CLIMATIC CONDITIONS	8
2.6 INSTRUMENT LIST	9
2.7 MEASUREMENT UNCERTAINTY	10
3 CONDUCTED EMISSION	11
3.1 LIMITS.....	11
3.1.1 <i>Limits for conducted emission of class A device</i>	11
3.1.2 <i>Limits for conducted emission of class B device</i>	11
3.2 TEST SETUP	12
3.3 TEST SETUP AND TEST PROCEDURE	13
3.4 TEST PROTOCOL.....	14
4 RADIATED EMISSION	16
4.1 RADIATED EMISSION LIMITS	16
4.1.1 <i>Limits for radiated emission of class A device</i>	16
4.1.2 <i>Limits for radiated emission of class B device</i>	16
4.2 BLOCK DIAGRAM AND TEST SET UP	17
4.3 TEST SETUP AND TEST PROCEDURE	18
4.4 TEST PROTOCOL.....	19

Revision History

Report No.	Version	Description	Issued Date
220900941SHA-001	Rev. 01	Initial issue of report	November 23,2022

Measurement result summary

TEST ITEM	FCC REFERENCE	TEST RESULT	NOTE
Conducted emission	15.107	Pass	
Radiation emission	15.109	Pass	

Notes: 1: NA =Not Applicable

2. Determination of the test conclusion is based on IEC Guide 115 in consideration of measurement uncertainty.

3: Additions, Deviations and Exclusions from Standards: None.

1 GENERAL INFORMATION**1.1 Description of Equipment Under Test (EUT)**

Product Name : Self-ballasted LED lamps
Type/Model : LED2219G3
Description of EUT : We tested it, and listed the worst data.
Rating : AC 120V, 60Hz, 3.3W, 40mA, E26
Brand name : IKEA
Category of EUT : Class B
EUT type : Table top
 Floor standing
Sample received date : October 20, 2022
Sample identification No. : 0221020-16
Date of test : October 20-25, 2022

1.2 Description of Test Facility

Name : Intertek Testing Services Shanghai

Address : Building 86, No. 1198 Qinzhou Road(North), Shanghai 200233, P.R. China

Telephone : 86 21 61278200

Telefax : 86 21 54262353

The test facility is recognized, certified, or accredited by these organizations :

- CNAS Accreditation Lab
Registration No. CNAS L0139
- FCC Accredited Lab
Designation Number: CN0175

- IC Registration Lab
CAB identifier.: CN0051

- VCCI Registration Lab
Registration No.: R-14243, G-10845, C-14723, T-12252

- A2LA Accreditation Lab
Certificate Number: 3309.02

2 TEST SPECIFICATIONS

2.1 Standards or specification

47CFR Part 15 (2020): Radio Frequency Device: Subpart B

ANSI C63.4 (2014): Interim Standard for Methods of Measurement of Radio-Noise Emissions from Low-Voltage Electrical and Electronic Equipment in the Range of 9 kHz to 40GHz.

2.2 Mode of operation during the test

Within this test report, EUT was tested under all available operation modes and tested under its rating voltage and frequency. Other voltage and frequency is specified if used.

2.3 Test software list

Test Items	Software	Manufacturer	Version
Conducted emission	ESxS-K1	R&S	V2.1.0
Radiated emission	ES-K1	R&S	V1.71

2.4 Test peripherals list

Item No.	Name	Band and Model	Description

2.5 Record of climatic conditions

Test Item	Temperature (°C)	Relative Humidity (%)	Pressure (Kpa)
Conducted emission	23	50	101
Radiated Emission	23	48	101

Notes: NA =Not Applicable

2.6 Instrument list

Conducted Emission / Disturbance Power / Tri-loop Test / CDN method					
Used	Equipment	Manufacturer	Type	Internal no.	Due date
<input checked="" type="checkbox"/>	Test Receiver	R&S	ESCS 30	EC 2107	2023-07-8
<input checked="" type="checkbox"/>	A.M.N.	R&S	ESH2-Z5	EC 3119	2023-11-8
<input checked="" type="checkbox"/>	Shielded room	Zhongyu	-	EC 2838	2023-01-11
Radiated Emission					
Used	Equipment	Manufacturer	Type	Internal no.	Due date
<input checked="" type="checkbox"/>	Test Receiver	R&S	ESIB 26	EC 3045	2023-10-18
<input checked="" type="checkbox"/>	Bilog Antenna	TESEQ	CBL 6112B	EC 6411	2023-8-5
<input checked="" type="checkbox"/>	Semi-anechoic chamber	Albatross project	-	EC 3048	2023-08-21
Additional instrument					
Used	Equipment	Manufacturer	Type	Internal no.	Due date
<input checked="" type="checkbox"/>	Therom-Hygrograph	ZJ1-2A	S.M.I.F.	EC 3783	2023-03-24
<input checked="" type="checkbox"/>	Therom-Hygrograph	ZJ1-2A	S.M.I.F.	EC 5198	2023-03-08
<input checked="" type="checkbox"/>	Pressure meter	YM3	Shanghai Mengde	EC 3320	2023-07-21

2.7 Measurement Uncertainty

Measurement	Frequency	Expanded Uncertainty (k=2) (±)
Conducted emission at mains ports	9kHz ~ 150kHz	3.71 dB
	150kHz ~ 30MHz	3.31 dB
Radiated Emissions up to 1 GHz	30MHz ~ 1GHz	5.04 dB
Radiated Emissions above 1 GHz	1GHz ~ 6GHz	4.97 dB
	6GHz ~ 18GHz	5.29 dB

3 Conducted emission

Test result: Pass

3.1 Limits

3.1.1 Limits for conducted emission of class A device

Frequency range (MHz)	Limits dB(μV)	
	Quasi-peak	Average
0.15 ~ 0.5	79	66
0.5 ~ 30	73	60

Note: If the limit for the measurement with the average detector is met when using a receiver with a quasi-peak detector, the equipment under test shall be deemed to meet both limits and the measurement using the receiver with an average detector need not be carried out.

3.1.2 Limits for conducted emission of class B device

Frequency range (MHz)	Limits dB(μV)	
	Quasi-peak	Average
0.15 ~ 0.5	66 ~ 56 *	56 ~ 46 *
0.5 ~ 5	56	46
5 ~ 30	60	50

Note: 1. * Means the limit decreasing linearly with the logarithm of the frequency in the range 0.15MHz to 0.5MHz
 2. If the limit for the measurement with the average detector is met when using a receiver with a quasi-peak detector, the equipment under test shall be deemed to meet both limits and the measurement using the receiver with an average detector need not be carried out.

3.2 Test setup

For table top equipment

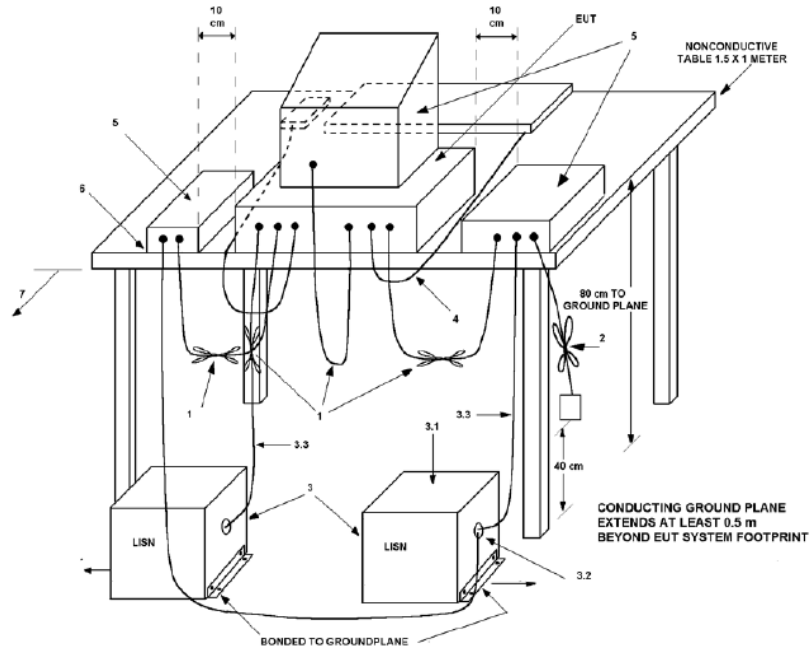

For floor standing equipment

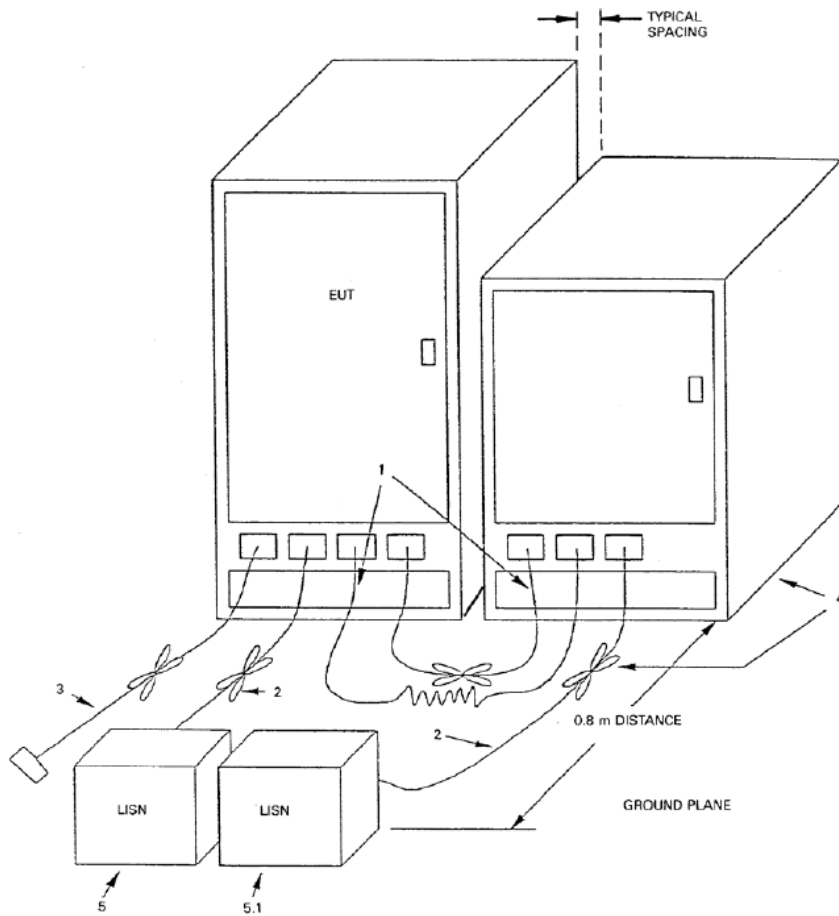

3.3 Test Setup and Test Procedure

Measurement was performed in shielded room, and instruments used were following clause 4 and clause 5 of ANSI 63.4.

Detailed test procedure was following clause 7.3 of ANSI 63.4.

EUT arrangement and operation conditions were according to clause 6 and clause 7 of ANSI 63.4.

Frequency range 150kHz – 30MHz was checked and EMI receiver measurement bandwidth was set to 9 kHz.

3.4 Test Protocol

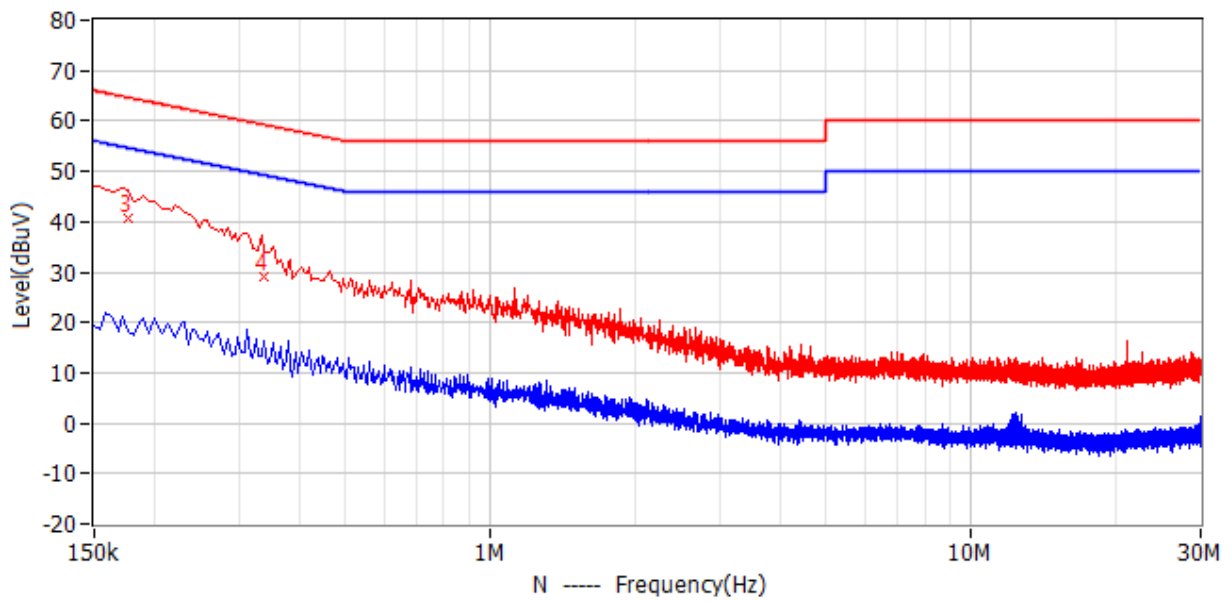
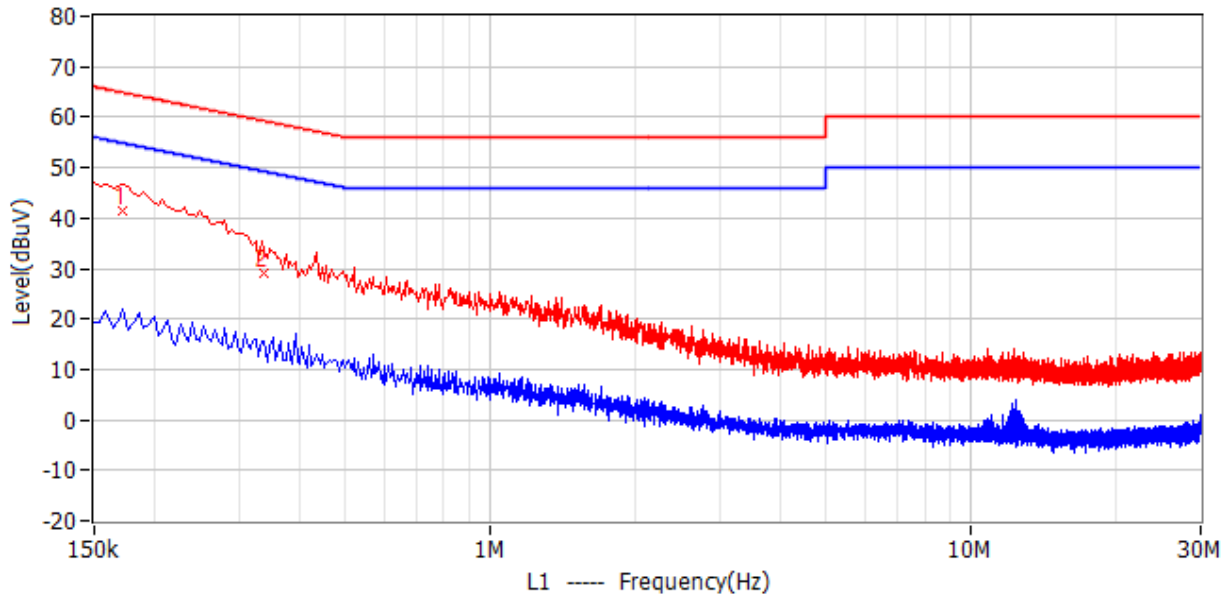

No.	Frequency	Limit dBuV	Level dBuV	Delta dB	Reading dBuV	Factor dB	Detector	Phase
1	172.500kHz	64.8	41.4	-23.4	35.3	6.1	QP	L1
2	339.000kHz	59.2	28.9	-30.3	22.7	6.2	QP	L1
3	177.000kHz	64.6	40.6	-24.1	34.4	6.2	QP	N
4	339.000kHz	59.2	29.2	-30.0	23.0	6.2	QP	N

Note: * means the emission level 20dB below the relevant limit.

Remark: 1. Correct Factor = LISN Factor + Cable Loss, the value was added to Original Receiver Reading by the software automatically.

2. Corrected Reading = Original Receiver Reading + Correct Factor

Total Quality. Assured.

3. Margin = Limit - Corrected Reading

4. If the PK Corrected Reading is lower than AV limit, the AV test can be elided.

Example: Assuming LISN Factor = 10.00dB, Cable Loss = 2.00dB,
Original Receiver Reading = 10.00dBuV, Limit = 66.00dBuV.
Then Correct Factor = 10.00 + 2.00 = 12.00dB;
Corrected Reading = 10dBuV + 12.00dB = 22.00dBuV;
Margin = 66.00dBuV – 22.00dBuV = 44.00dB.

4 Radiated emission

Test result: **PASS**

4.1 Radiated emission limits

4.1.1 Limits for radiated emission of class A device

Frequency (MHz)	Permitted limit in dB μ V/m (Quasi-peak) of Measurement Distance 10m
30 ~ 88	39
88 ~ 216	43.5
216 ~ 960	46.4
Above 960	49.5

Note: for the measurement distance other than 3m and 10m, the limit is varied according to 20dB/10 decades.

4.1.2 Limits for radiated emission of class B device

Frequency (MHz)	Permitted limit in dB μ V/m (Quasi-peak) of Measurement Distance 3m
30 ~ 88	40.0
88 ~ 216	43.5
216 ~ 960	46.0
Above 960	54.0

Note: for the measurement distance other than 3m and 10m, the limit is varied according to 20dB/10 decades.

4.2 Block diagram and test set up

For table top equipment

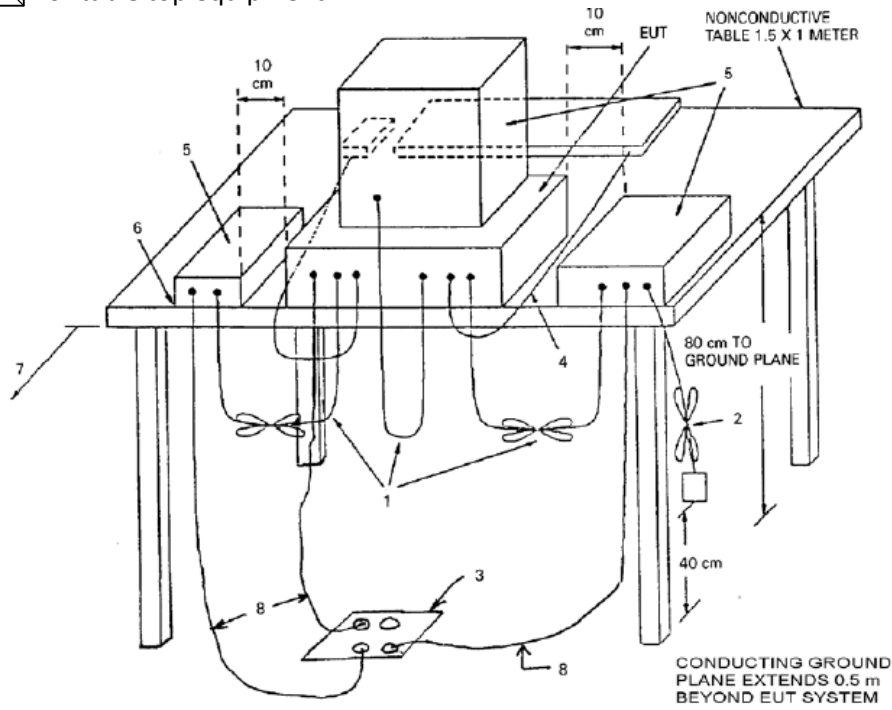

For floor standing equipment

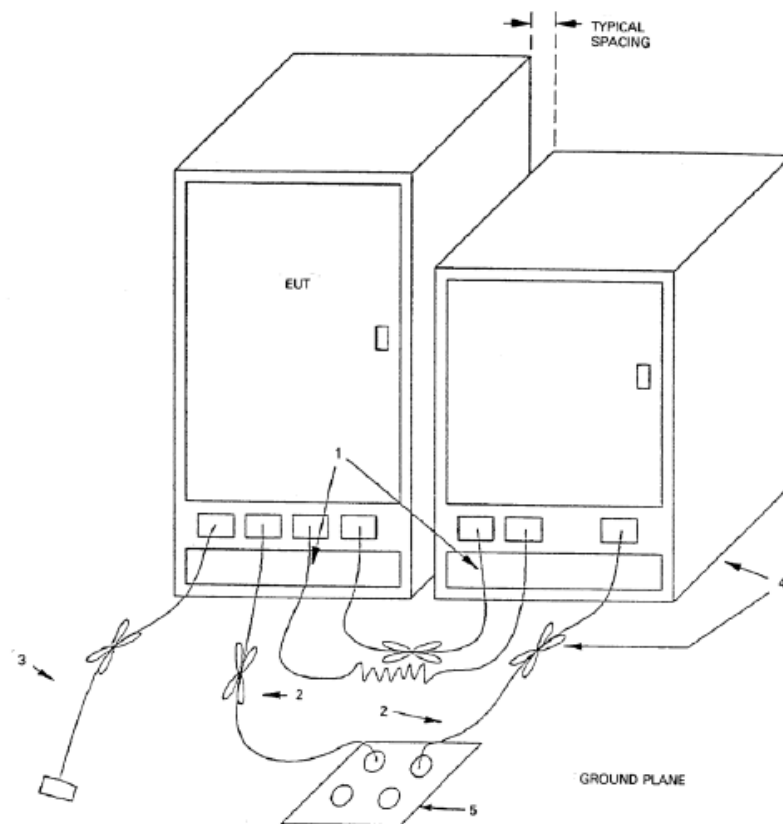

4.3 Test Setup and Test Procedure

The measurement was performed in a semi-anechoic chamber.

The distance from EUT to receiving antenna is 3 meter.

Measurement was performed according to clause 4 and clause 5 of ANSI 63.4.

Test procedure was according to clause 8.3 of ANSI 63.4.

EUT arrangement and operate condition were according to clause 6 and clause 8 of ANSI 63.4.

The bandwidth setting on R&S Test Receiver was 120 kHz.

The required measurement frequency range was checked.

4.4 Test Protocol

Test Curve:

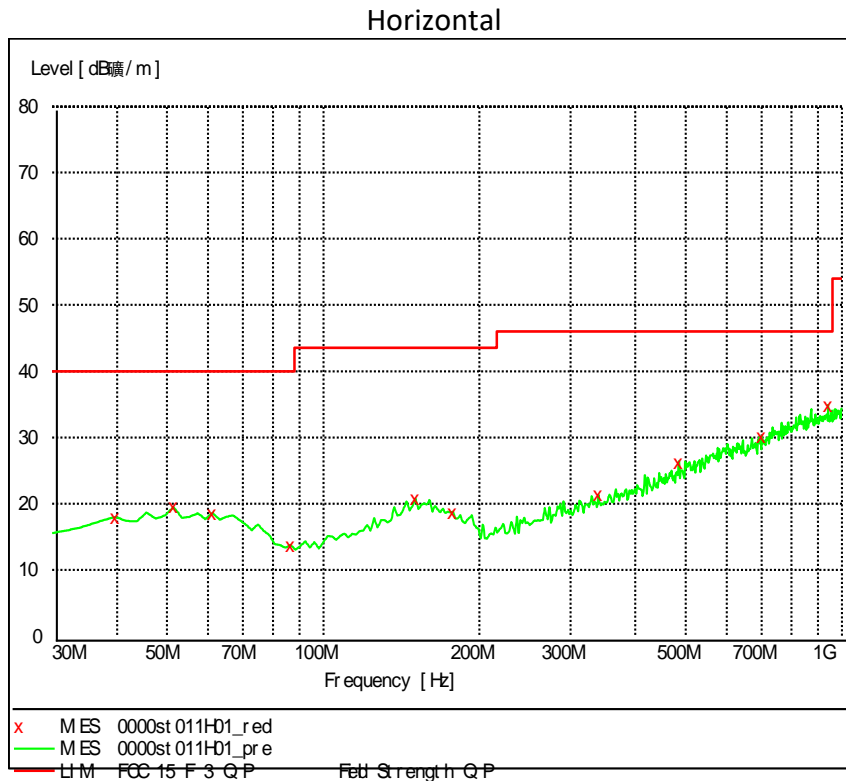

Frequency MHz	Level dBuV/m	Transd dB	Limit dBuV/m	Margin dB
39.719439	18.00	13.8	40.0	22.0
51.382766	19.50	14.5	40.0	20.5
61.102204	18.60	14.0	40.0	21.4
86.372745	13.70	9.2	40.0	26.3
150.521042	20.80	14.9	43.5	22.7
177.735471	18.70	13.3	43.5	24.8
339.078156	21.30	16.2	46.0	24.7
484.869739	26.30	19.8	46.0	19.7
700.641283	30.20	23.5	46.0	15.8
941.683367	34.90	26.7	46.0	11.1

Vertical

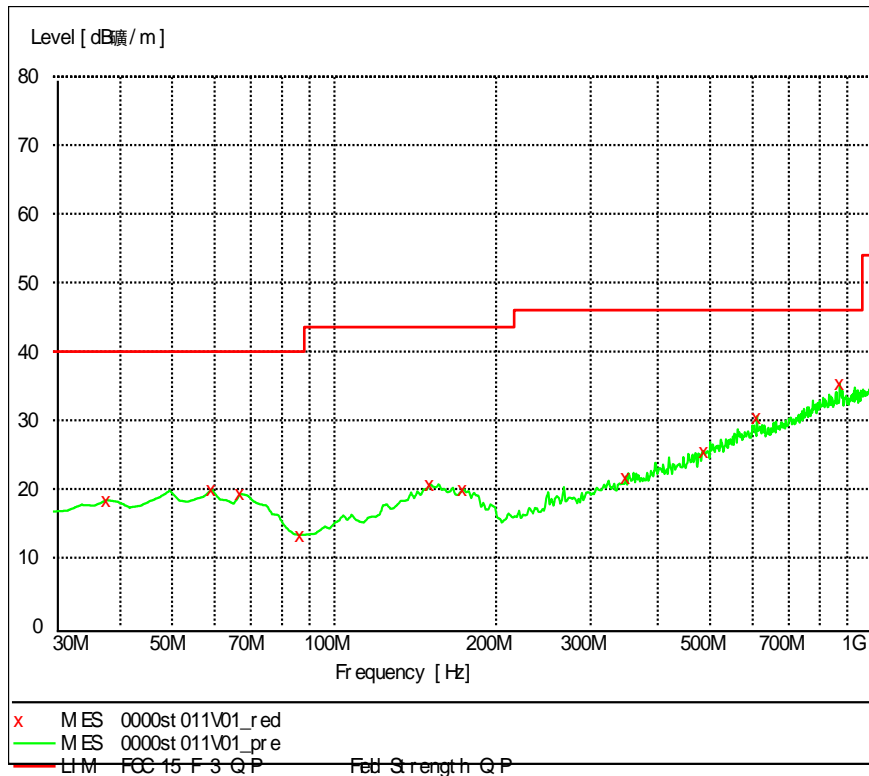

Frequency MHz	Level dBμV/m	Transd dB	Limit dBμV/m	Margin dB
37.775551	18.40	13.6	40.0	21.6
59.158317	19.90	14.2	40.0	20.1
66.933868	19.30	13.1	40.0	20.7
86.372745	13.30	9.2	40.0	26.7
150.521042	20.70	14.9	43.5	22.8
173.847695	20.00	13.6	43.5	23.5
348.797595	21.70	16.4	46.0	24.3
486.813627	25.50	19.9	46.0	20.5
611.222445	30.40	22.4	46.0	15.6
871.703407	35.40	26.0	46.0	10.6

- Remark: 1. Correct Factor = Antenna Factor + Cable Loss (+ Amplifier, for higher than 1GHz)
- 2. Corrected Reading = Original Receiver Reading + Correct Factor
- 3. Margin = Limit - Corrected Reading
- 4. If the PK Corrected Reading is lower than AV limit, the AV test can be elided.

Example: Assuming Antenna Factor = 30.20dB/m, Cable Loss = 2.00dB,
Gain of Preamplifier = 32.00dB, Original Receiver Reading = 10.00dBμV, limit = 40.00dBμV/m.
Then Correct Factor = 30.20 + 2.00 – 32.00 = 0.20dB/m; Corrected Reading = 10dBμV +
0.20dB/m = 10.20dBμV/m; Margin = 40.00dBμV/m - 10.20dBμV/m = 29.80dB.

*****END of the report*****