

IKEA of Sweden AB  
**TEST REPORT**

**SCOPE OF WORK:**  
FCC Part 15 subpart B – EMC report

**Model:**  
LED1905G12

**REPORT NUMBER**  
190701049SHA-001

**ISSUE DATE**  
October 31, 2019

**DOCUMENT CONTROL NUMBER**  
TTRFFCCPART15b\_V1  
© 2018 Intertek



**Applicant** : **IKEA of Sweden AB**  
**Box 702, SE-343 81 Älmhult, SWEDEN**

**Manufacturer** : **Same as applicant**

**Manufacturing site** : **Jinzhai Yankon Lufei Lighting Co., Ltd.**  
**Building D7, Jinwutong Pioneer Park, Meishanhu Road,**  
**Jinzhai County Modern Industrial Park, Lu'an City, Anhui**  
**Province, CHINA**

### Summary

The equipment complies with the requirements according to the following standard(s) or Specification:

**47CFR Part 15 (2018):** Radio Frequency Devices (Subpart B)

**ANSI C63.4 (2014):** American National Standard for Methods of Measurement of Radio-Noise Emissions from Low-Voltage Electrical and Electronic Equipment in the Range of 9 kHz to 40 GHz

**PREPARED BY:**

**REVIEWED BY:**

Star Guo  
Project Engineer

Andy Chen  
Reviewer

This report is for the exclusive use of Intertek's Client and is provided pursuant to the agreement between Intertek and its Client. Intertek's responsibility and liability are limited to the terms and conditions of the agreement. Intertek assumes no liability to any party, other than to the Client in accordance with the agreement, for any loss, expense or damage occasioned by the use of this report. Only the Client is authorized to permit copying or distribution of this report and then only in its entirety. Any use of the Intertek name or one of its marks for the sale or advertisement of the tested material, product or service must first be approved in writing by Intertek. The observations and test results in this report are relevant only to the sample tested. This report by itself does not imply that the material, product, or service is or has ever been under an Intertek certification program.

## Contents

<b>REVISION HISTORY</b> .....	<b>4</b>
<b>MEASUREMENT RESULT SUMMARY</b> .....	<b>5</b>
<b>1 GENERAL INFORMATION</b> .....	<b>6</b>
1.1 DESCRIPTION OF EQUIPMENT UNDER TEST (EUT) .....	6
1.2 DESCRIPTION OF TEST FACILITY .....	7
<b>2 TEST SPECIFICATIONS</b> .....	<b>8</b>
2.1 STANDARDS OR SPECIFICATION .....	8
2.2 MODE OF OPERATION DURING THE TEST.....	8
2.3 TEST SOFTWARE LIST .....	8
2.4 TEST PERIPHERALS LIST .....	8
2.5 RECORD OF CLIMATIC CONDITIONS .....	8
2.6 INSTRUMENT LIST .....	9
2.7 MEASUREMENT UNCERTAINTY .....	10
<b>3 CONDUCTED EMISSION</b> .....	<b>11</b>
3.1 LIMITS.....	11
3.1.1 <i>Limits for conducted emission of class A device</i> .....	11
3.1.2 <i>Limits for conducted emission of class B device</i> .....	11
3.2 TEST SETUP .....	12
3.3 TEST SETUP AND TEST PROCEDURE .....	13
3.4 TEST PROTOCOL.....	14
<b>4 RADIATED EMISSION</b> .....	<b>16</b>
4.1 RADIATED EMISSION LIMITS .....	16
4.1.1 <i>Limits for radiated emission of class A device</i> .....	16
4.1.2 <i>Limits for radiated emission of class B device</i> .....	16
4.2 BLOCK DIAGRAM AND TEST SET UP .....	17
4.3 TEST SETUP AND TEST PROCEDURE .....	18
4.4 TEST PROTOCOL.....	19

### Revision History

Report No.	Version	Description	Issued Date
190701049SHA-001	Rev. 01	Initial issue of report	October 31, 2019

## Measurement result summary

TEST ITEM	FCC REFERANCE	TEST RESULT	NOTE
Conducted emission	15.107	Pass	
Radiation emission	15.109	Pass	

Notes: 1: NA =Not Applicable

2. Determination of the test conclusion is based on IEC Guide 115 in consideration of measurement uncertainty.

3: Additions, Deviations and Exclusions from Standards: None.

## 1 GENERAL INFORMATION

### 1.1 Description of Equipment Under Test (EUT)

Product Name : Self-ballasted LED lamps  
Type/Model : LED1905G12  
Description of EUT : We tested it, and listed the worst data.  
Rating : AC120V, 60Hz, 12.2W, 120mA, with E26 lamp cap  
Brand name : IKEA  
Category of EUT : Class B  
EUT type :  Table top  
                   Floor standing  
Sample received date : August 21, 2019  
Sample identification No. : 0190725-15  
Date of test : August 25, 2019

## 1.2 Description of Test Facility

Name : Intertek Testing Services Shanghai

Address : Building 86, No. 1198 Qinzhou Road(North), Shanghai 200233, P.R.  
China

Telephone : 86 21 61278200

Telefax : 86 21 54262353

The test facility is recognized, certified, or accredited by these organizations :

- CNAS Accreditation Lab  
Registration No. CNAS L0139
- FCC Accredited Lab  
Designation Number: CN1175
- IC Registration Lab  
CAB identifier.: CN0051
- VCCI Registration Lab  
Registration No.: R-14243, G-10845, C-14723, T-12252
- A2LA Accreditation Lab  
Certificate Number: 3309.02

## 2 TEST SPECIFICATIONS

### 2.1 Standards or specification

**47CFR Part 15 (2018):** Radio Frequency Device: Subpart B

**ANSI C63.4 (2014):** Interim Standard for Methods of Measurement of Radio-Noise Emissions from Low-Voltage Electrical and Electronic Equipment in the Range of 9 kHz to 40GHz.

### 2.2 Mode of operation during the test

Within this test report, EUT was tested under all available operation modes and tested under its rating voltage and frequency. Other voltage and frequency is specified if used.

### 2.3 Test software list

Test Items	Software	Manufacturer	Version
Conducted emission	ESxS-K1	R&S	V2.1.0
Radiated emission	ES-K1	R&S	V1.71

### 2.4 Test peripherals list

Item No.	Name	Band and Model	Description

### 2.5 Record of climatic conditions

Test Item	Temperature (°C)	Relative Humidity (%)	Pressure (Kpa)
Conducted emission	24	42	101
Radiated Emission	24	42	101

Notes: NA =Not Applicable



## 2.6 Instrument list

Conducted Emission / Disturbance Power / Tri-loop Test / CDN method					
Used	Equipment	Manufacturer	Type	Internal no.	Due date
<input checked="" type="checkbox"/>	Test Receiver	R&S	ESCS 30	EC 2107	2020-07-15
<input checked="" type="checkbox"/>	A.M.N.	R&S	ESH2-Z5	EC 3119	2019-11-29
<input checked="" type="checkbox"/>	Shielded room	Zhongyu	-	EC 2838	2020-01-13
Radiated Emission					
Used	Equipment	Manufacturer	Type	Internal no.	Due date
<input checked="" type="checkbox"/>	Test Receiver	R&S	ESIB 26	EC 3045	2020-09-12
<input checked="" type="checkbox"/>	Bilog Antenna	TESEQ	CBL 6112D	EC 4206	2020-06-10
<input checked="" type="checkbox"/>	Semi-anechoic chamber	Albatross project	-	EC 3048	2020-07-31
Additional instrument					
Used	Equipment	Manufacturer	Type	Internal no.	Due date
<input checked="" type="checkbox"/>	Therom-Hygrograph	ZJ1-2A	S.M.I.F.	EC 3326	2020-03-28
<input checked="" type="checkbox"/>	Therom-Hygrograph	ZJ1-2A	S.M.I.F.	EC 3783	2020-02-28
<input checked="" type="checkbox"/>	Pressure meter	YM3	Shanghai Mengde	EC 3320	2020-07-01

## 2.7 Measurement Uncertainty

Measurement	Frequency	Expanded Uncertainty (k=2) (±)
Conducted emission at mains ports	9kHz ~ 150kHz	3.71 dB
	150kHz ~ 30MHz	3.31 dB
Radiated Emissions up to 1 GHz	30MHz ~ 1GHz	5.04 dB
Radiated Emissions above 1 GHz	1GHz ~ 6GHz	4.97 dB
	6GHz ~ 18GHz	5.29 dB

### 3 Conducted emission

Test result: **PASS**

#### 3.1 Limits

##### 3.1.1 Limits for conducted emission of class A device

Frequency range (MHz)	Limits dB(μV)	
	Quasi-peak	Average
0.15 ~ 0.5	79	66
0.5 ~ 30	73	60

Note: If the limit for the measurement with the average detector is met when using a receiver with a quasi-peak detector, the equipment under test shall be deemed to meet both limits and the measurement using the receiver with an average detector need not be carried out.

##### 3.1.2 Limits for conducted emission of class B device

Frequency range (MHz)	Limits dB(μV)	
	Quasi-peak	Average
0.15 ~ 0.5	66 ~ 56 *	56 ~ 46 *
0.5 ~ 5	56	46
5 ~ 30	60	50

Note: 1. \* Means the limit decreasing linearly with the logarithm of the frequency in the range 0.15MHz to 0.5MHz  
2. If the limit for the measurement with the average detector is met when using a receiver with a quasi-peak detector, the equipment under test shall be deemed to meet both limits and the measurement using the receiver with an average detector need not be carried out.

**3.2 Test setup**

For table top equipment

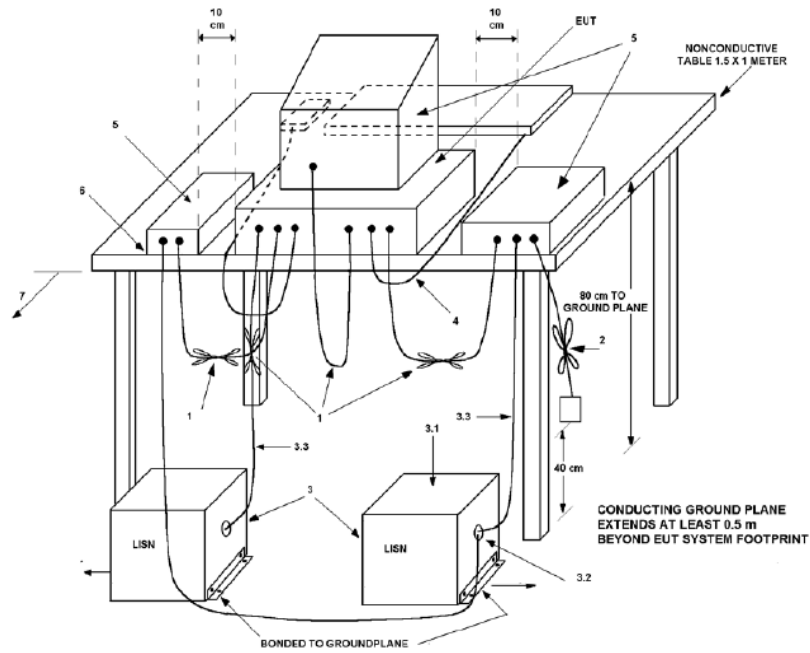

For floor standing equipment

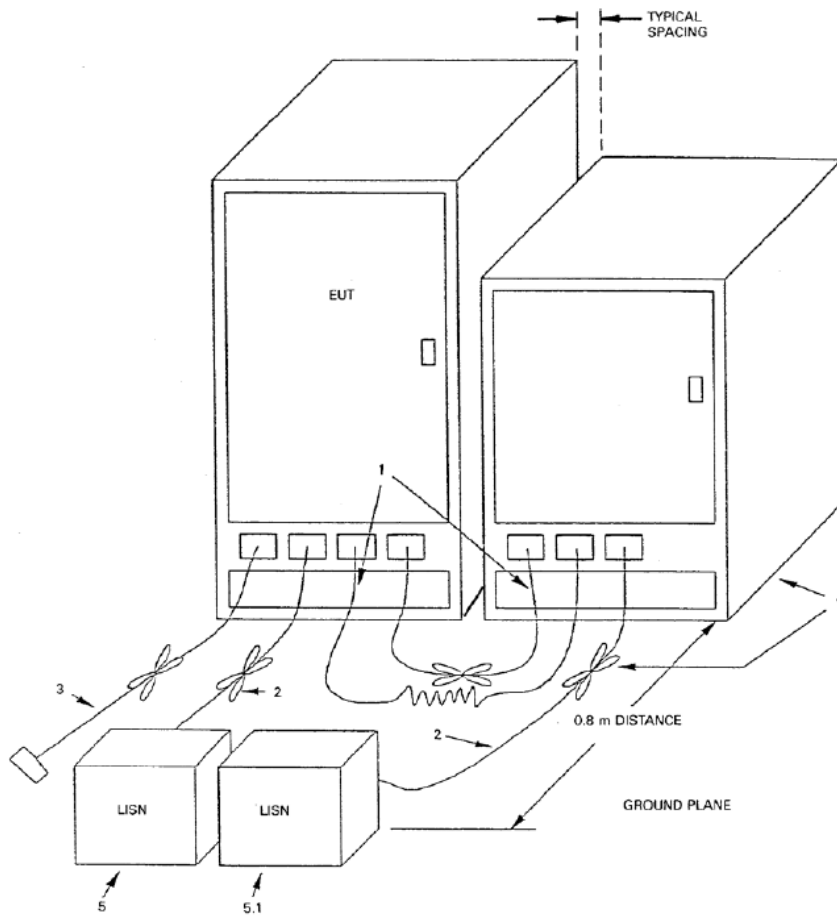

### **3.3 Test Setup and Test Procedure**

Measurement was performed in shielded room, and instruments used were following clause 4 and clause 5 of ANSI 63.4.

Detailed test procedure was following clause 7.3 of ANSI 63.4.

EUT arrangement and operation conditions were according to clause 6 and clause 7 of ANSI 63.4.

Frequency range 150kHz – 30MHz was checked and EMI receiver measurement bandwidth was set to 9 kHz.

### 3.4 Test Protocol

L line:

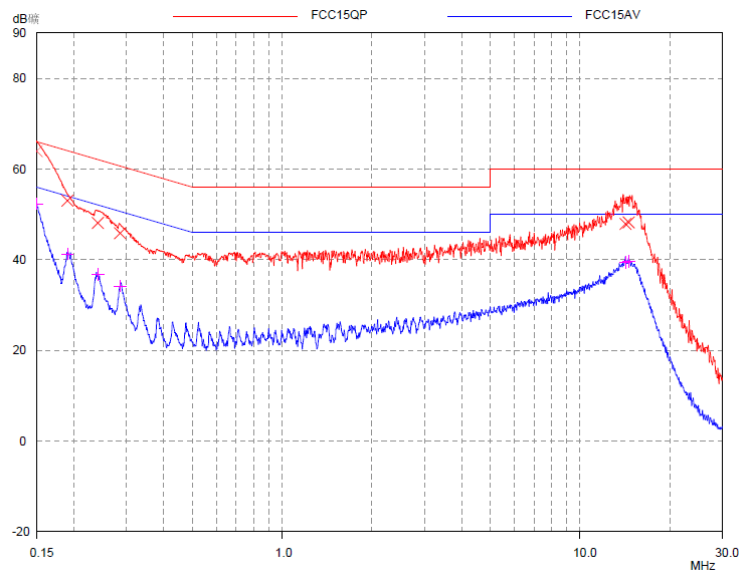

#### Final Measurement Results

Frequency MHz	QP Level dB $\mu$ V	QP Limit dB $\mu$ V	QP Delta dB
0.15	63.92	66.00	2.08
0.18983	53.04	64.04	11.00
0.24025	48.12	62.09	13.97
0.28524	45.86	60.66	14.80
14.2077	47.94	60.00	12.06
14.55211	48.24	60.00	11.76

Frequency MHz	AV Level dB $\mu$ V	AV Limit dB $\mu$ V	AV Delta dB
0.15	52.35	56.00	3.65
0.18983	41.26	54.04	12.78
0.24025	36.75	52.09	15.34
0.28524	34.16	50.66	16.50
14.2077	39.38	50.00	10.62
14.55211	39.61	50.00	10.39

N line:

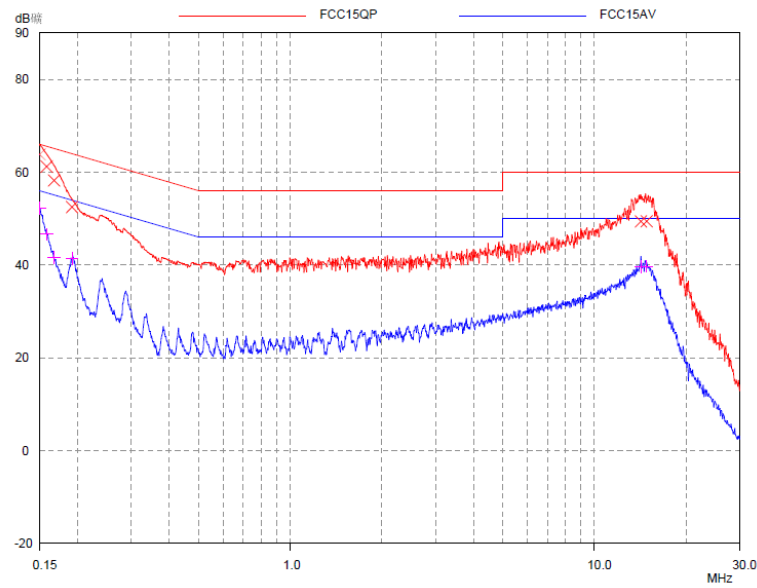

Final Measurement Results

Frequency MHz	QP Level dBµV	QP Limit dBµV	QP Delta dB
0.15	63.82	66.00	2.18
0.15798	61.22	65.57	4.35
0.16707	58.23	65.10	6.87
0.19135	52.50	63.98	11.48
14.2077	49.41	60.00	10.59
14.84549	49.42	60.00	10.58

Frequency MHz	AV Level dBµV	AV Limit dBµV	AV Delta dB
0.15	52.26	56.00	3.74
0.15798	46.66	55.57	8.91
0.16707	41.62	55.10	13.48
0.19135	41.41	53.98	12.57
14.2077	39.64	50.00	10.36
14.84549	39.72	50.00	10.28

Remark: 1. Correct Factor = LISN Factor + Cable Loss, the value was added to Original Receiver Reading by the software automatically.

2. Corrected Reading = Original Receiver Reading + Correct Factor

3. Margin = Limit - Corrected Reading

4. If the PK Corrected Reading is lower than AV limit, the AV test can be elided.

Example: Assuming LISN Factor = 10.00dB, Cable Loss = 2.00dB,  
Original Receiver Reading = 10.00dBuV, Limit = 66.00dBuV.  
Then Correct Factor = 10.00 + 2.00 = 12.00dB;  
Corrected Reading = 10dBuV + 12.00dB = 22.00dBuV;  
Margin = 66.00dBuV – 22.00dBuV = 44.00dB.

## 4 Radiated emission

**Test result: PASS**

### 4.1 Radiated emission limits

#### 4.1.1 Limits for radiated emission of class A device

Frequency (MHz)	Permitted limit in dB $\mu$ V/m (Quasi-peak) of Measurement Distance 10m
30 ~ 88	39
88 ~ 216	43.5
216 ~ 960	46.4
Above 960	49.5

Note: for the measurement distance other than 3m and 10m, the limit is varied according to 20dB/10 decades.

#### 4.1.2 Limits for radiated emission of class B device

Frequency (MHz)	Permitted limit in dB $\mu$ V/m (Quasi-peak) of Measurement Distance 3m
30 ~ 88	40.0
88 ~ 216	43.5
216 ~ 960	46.0
Above 960	54.0

Note: for the measurement distance other than 3m and 10m, the limit is varied according to 20dB/10 decades.



**4.2 Block diagram and test set up**

For table top equipment

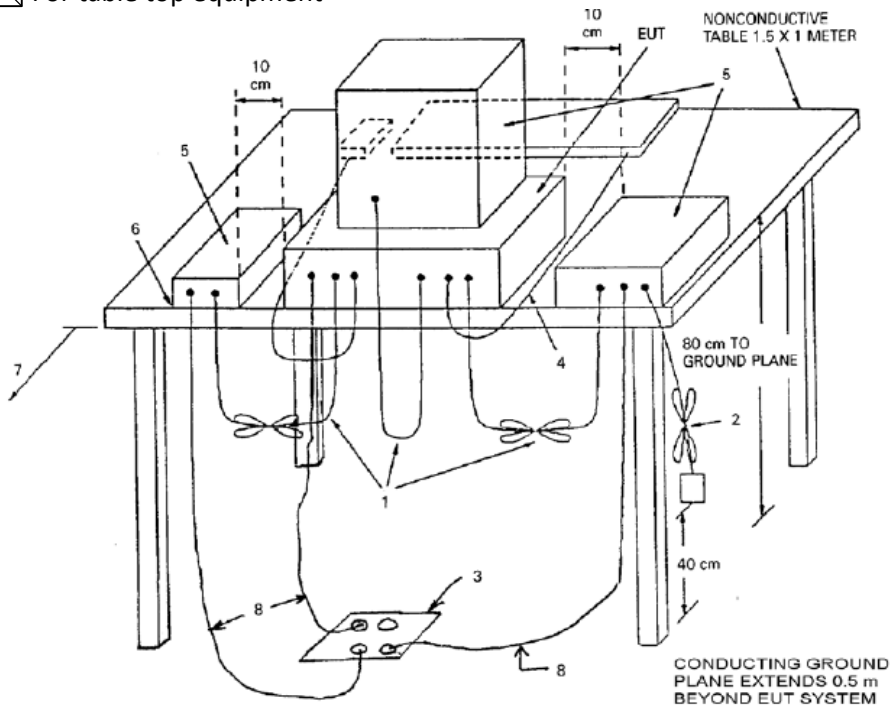

For floor standing equipment

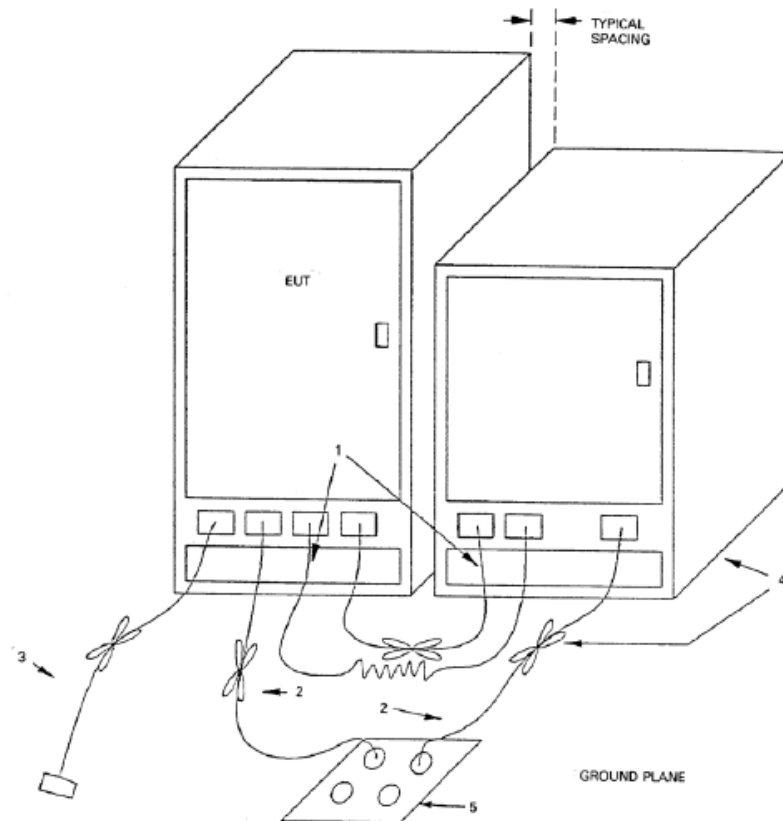

### **4.3 Test Setup and Test Procedure**

The measurement was performed in a semi-anechoic chamber.

The distance from EUT to receiving antenna is 3 meter.

Measurement was performed according to clause 4 and clause 5 of ANSI 63.4.

Test procedure was according to clause 8.3 of ANSI 63.4.

EUT arrangement and operate condition were according to clause 6 and clause 8 of ANSI 63.4.

The bandwidth setting on R&S Test Receiver was 120 kHz.

The required measurement frequency range was checked.

### 4.4 Test Protocol

Test Curve:

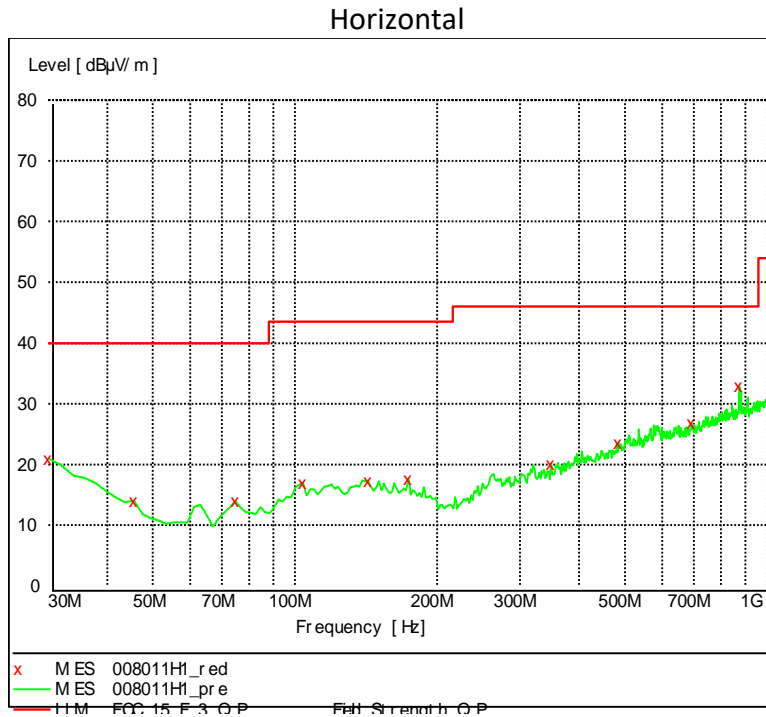

Frequency MHz	Level dBuV/m	Transd dB	Limit dBuV/m	Margin dB
30.000000	21.00	18.8	40.0	19.0
45.551102	14.00	10.7	40.0	26.0
74.709419	14.00	7.6	40.0	26.0
103.867735	16.90	12.3	43.5	26.6
142.745491	17.40	12.4	43.5	26.1
173.847695	17.70	10.8	43.5	25.8
348.797595	20.10	16.4	46.0	25.9
484.869739	23.50	19.4	46.0	22.5
690.921844	26.90	21.6	46.0	19.1
873.647295	32.90	23.5	46.0	13.1

Vertical

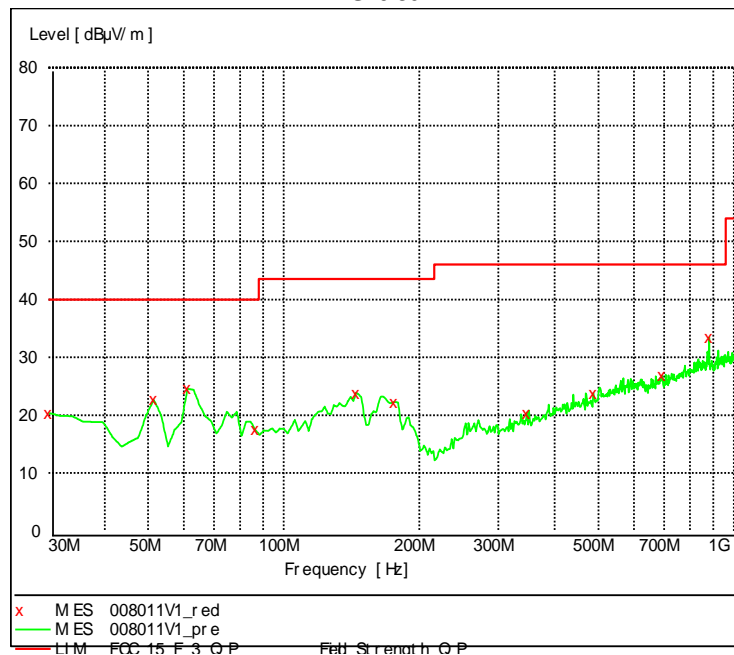

Frequency MHz	Level dBuV/m	Transd dB	Limit dBuV/m	Margin dB
30.000000	20.40	18.8	40.0	19.6
51.382766	22.70	8.5	40.0	17.3
61.102204	24.60	7.1	40.0	15.4
86.372745	17.50	9.3	40.0	22.5
144.689379	23.90	12.2	43.5	19.6
175.791583	22.30	10.8	43.5	21.2
346.853707	20.40	16.3	46.0	25.6
486.813627	23.80	19.4	46.0	22.2
692.865731	26.80	21.6	46.0	19.2
881.422846	33.40	23.6	46.0	12.6

- Remark: 1. Correct Factor = Antenna Factor + Cable Loss (+ Amplifier, for higher than 1GHz)  
 2. Corrected Reading = Original Receiver Reading + Correct Factor  
 3. Margin = Limit - Corrected Reading  
 4. If the PK Corrected Reading is lower than AV limit, the AV test can be elided.

Example: Assuming Antenna Factor = 30.20dB/m, Cable Loss = 2.00dB,  
 Gain of Preamplifier = 32.00dB, Original Receiver Reading = 10.00dBuV, limit = 40.00dBuV/m.  
 Then Correct Factor = 30.20 + 2.00 – 32.00 = 0.20dB/m; Corrected Reading = 10dBuV +  
 0.20dB/m = 10.20dBuV/m; Margin = 40.00dBuV/m - 10.20dBuV/m = 29.80dB.

**\*\*\*END of the report\*\*\***