



FCC TEST REPORT (15.407)

REPORT NO.: RF111026C09-1
MODEL NO.: WLI-UTX-AG300
FCC ID: FDI-09102114-0
RECEIVED: Oct. 26, 2011
TESTED: Nov. 07 ~ Dec. 01, 2011
ISSUED: Dec. 05, 2011

APPLICANT: BUFFALO INC.

ADDRESS: Akamon-dori Bldg, 30-20, Ohsu 3-chome,
Naka-ku ,Nagoya 460-8315, Japan

ISSUED BY: Bureau Veritas Consumer Products Services
(H.K.) Ltd., Taoyuan Branch

LAB ADDRESS: No. 47, 14th Ling, Chia Pau Vil., Lin Kou Dist.,
New Taipei City, Taiwan (R.O.C)

TEST LOCATION: No. 19, Hwa Ya 2nd Rd, Wen Hwa Tsuen, Kwei
Shan Hsiang, Taoyuan Hsien 333, Taiwan,
R.O.C.

This test report consists of 75 pages in total. It may be duplicated completely for legal use with the approval of the applicant. It should not be reproduced except in full, without the written approval of our laboratory. The client should not use it to claim product certification, approval, or endorsement by TAF or any government agency. The test results in the report only apply to the tested sample.



TABLE OF CONTENTS

RELEASE CONTROL RECORD.....	4
1. CERTIFICATION.....	5
2. SUMMARY OF TEST RESULTS	6
2.1 MEASUREMENT UNCERTAINTY	6
3. GENERAL INFORMATION.....	7
3.1 GENERAL DESCRIPTION OF EUT.....	7
3.2 DESCRIPTION OF TEST MODES.....	8
3.2.1 CONFIGURATION OF SYSTEM UNDER TEST.....	9
3.2.2 TEST MODE APPLICABILITY AND TESTED CHANNEL DETAIL.....	10
3.3 GENERAL DESCRIPTION OF APPLIED STANDARDS	12
3.4 DESCRIPTION OF SUPPORT UNITS	12
4. TEST TYPES AND RESULTS	13
4.1 RADIATED EMISSION AND BANDEDGE MEASUREMENT.....	13
4.1.1 LIMITS OF RADIATED EMISSION AND BANDEDGE MEASUREMENT	13
4.1.2 LIMITS OF UNWANTED EMISSION OUT OF THE RESTRICTED BANDS.....	13
4.1.3 TEST INSTRUMENTS	14
4.1.4 TEST PROCEDURES	15
4.1.5 DEVIATION FROM TEST STANDARD	15
4.1.6 TEST SETUP	16
4.1.7 EUT OPERATING CONDITION	16
4.1.8 TEST RESULTS	17
4.2 CONDUCTED EMISSION MEASUREMENT	46
4.2.1 LIMITS OF CONDUCTED EMISSION MEASUREMENT.....	46
4.2.2 TEST INSTRUMENTS	46
4.2.3 TEST PROCEDURES	47
4.2.4 DEVIATION FROM TEST STANDARD	47
4.2.5 TEST SETUP	48
4.2.6 EUT OPERATING CONDITIONS.....	48
4.2.7 TEST RESULTS	49
4.3 MAXIMUM CONDUCTED OUTPUT POWER MEASUREMENT	53
4.3.1 LIMITS OF MAXIMUM CONDUCTED OUTPUT POWER MEASUREMENT	53
4.3.2 TEST SETUP	53
4.3.3 TEST INSTRUMENTS	53
4.3.4 TEST PROCEDURE	54



4.3.5	DEVIATION FROM TEST STANDARD	54
4.3.6	EUT OPERATING CONDITIONS	54
4.3.7	TEST RESULTS	55
4.4	PEAK POWER EXCURSION MEASUREMENT	59
4.4.1	LIMITS OF PEAK POWER EXCURSION MEASUREMENT.....	59
4.4.2	TEST SETUP	59
4.4.3	TEST INSTRUMENTS	59
4.4.4	TEST PROCEDURE	59
4.4.5	DEVIATION FROM TEST STANDARD	59
4.4.6	EUT OPERATING CONDITIONS	59
4.4.7	TEST RESULTS	60
4.5	PEAK POWER SPECTRAL DENSITY MEASUREMENT	66
4.5.1	LIMITS OF PEAK POWER SPECTRAL DENSITY MEASUREMENT.....	66
4.5.2	TEST SETUP	66
4.5.3	TEST INSTRUMENTS	66
4.5.4	TEST PROCEDURES	66
4.5.5	DEVIATION FROM TEST STANDARD	66
4.5.6	EUT OPERATING CONDITIONS	66
4.5.7	TEST RESULTS	67
4.6	FREQUENCY STABILITY	70
4.6.1	LIMITS OF FREQUENCY STABILITY MEASUREMENT	70
4.6.2	TEST SETUP	70
4.6.3	TEST INSTRUMENTS	70
4.6.4	TEST PROCEDURE	71
4.6.5	DEVIATION FROM TEST STANDARD	71
4.6.6	EUT OPERATING CONDITION	71
4.6.7	TEST RESULTS	72
5.	PHOTOGRAPHS OF THE TEST CONFIGURATION.....	73
6.	INFORMATION ON THE TESTING LABORATORIES	74
7.	APPENDIX A - MODIFICATIONS RECORDERS FOR ENGINEERING CHANGES TO THE EUT BY THE LAB.....	75



A D T

RELEASE CONTROL RECORD

ISSUE NO.	REASON FOR CHANGE	DATE ISSUED
Original release	N/A	Dec. 05, 2011



1. CERTIFICATION

PRODUCT: AirStation Wireless-N Media Bridge

MODEL: WLI-UTX-AG300

BRAND: Buffalo

APPLICANT: BUFFALO INC.

TEST SAMPLE: ENGINEERING SAMPLE

TESTED: Nov. 07 ~ Dec. 01, 2011

STANDARDS: FCC Part 15, Subpart E (Section 15.407)

ANSI C63.4-2003

ANSI C63.10-2009

The above equipment (Model: WLI-UTX-AG300) has been tested by **Bureau Veritas Consumer Products Services (H.K.) Ltd., Taoyuan Branch**, and found compliance with the requirement of the above standards. The test record, data evaluation & Equipment Under Test (EUT) configurations represented herein are true and accurate accounts of the measurements of the sample's EMC characteristics under the conditions specified in this report.

PREPARED BY :  , DATE: Dec. 05, 2011
Pettie Chen / Specialist

APPROVED BY :  , DATE: Dec. 05, 2011
Gary Chang / Technical Manager

2. SUMMARY OF TEST RESULTS

The EUT has been tested according to the following specifications:

APPLIED STANDARD: FCC PART 15, SUBPART E (SECTION 15.407)			
STANDARD SECTION	TEST TYPE AND LIMIT	RESULT	REMARK
15.407(b)(5)	AC Power Conducted Emission	PASS	Meet the requirement of limit. Minimum passing margin is -13.72dB at 0.170MHz.
15.407(b)(1/2/3) (b)(5)	Electric Field Strength Spurious Emissions, 30MHz ~ 40000MHz	PASS	Meet the requirement of limit. Minimum passing margin is -1.0dB at 5470.00 MHz, 5725.00MHz & 11160.00MHz & 11320MHz.
15.407(a)(1/2/3)	Peak Transmit Power	PASS	Meet the requirement of limit.
15.407(a)(6)	Peak Power Excursion	PASS	Meet the requirement of limit.
15.407(a)(1/2/3)	Peak Power Spectral Density	PASS	Meet the requirement of limit.
15.407(g)	Frequency Stability	PASS	Meet the requirement of limit.
15.203	Antenna Requirement	PASS	No antenna connector is used.

2.1 MEASUREMENT UNCERTAINTY

Where relevant, the following measurement uncertainty levels have been estimated for tests performed on the EUT as specified in CISPR 16-4-2:

MEASUREMENT	FREQUENCY	UNCERTAINTY
Conducted emissions	150kHz~30MHz	2.44 dB
Radiated emissions	30MHz ~ 200MHz	3.34 dB
	200MHz ~1000MHz	3.35 dB
	1GHz ~ 18GHz	2.26 dB
	18GHz ~ 40GHz	1.94 dB

This uncertainty represents an expanded uncertainty expressed at approximately the 95% confidence level using a coverage factor of $k = 2$.



3. GENERAL INFORMATION

3.1 GENERAL DESCRIPTION OF EUT

EUT	AirStation Wireless-N Media Bridge
MODEL NO.	WLI-UTX-AG300
FCC ID	FDI-09102114-0
POWER SUPPLY	5.0Vdc (host equipment)
MODULATION TYPE	64QAM, 16QAM, QPSK, BPSK
MODULATION TECHNOLOGY	OFDM
TRANSFER RATE	802.11a: 54.0/ 48.0/ 36.0/ 24.0/ 18.0/ 12.0/ 9.0/ 6.0Mbps 802.11n: up to 300.0Mbps
OPERATING FREQUENCY	5180 ~ 5320MHz & 5500 ~ 5700MHz
NUMBER OF CHANNEL	5180 ~ 5320MHz: 8 for 802.11a, 802.11n (20MHz) 4 for 802.11n (40MHz) 5500 ~ 5700MHz: 11 for 802.11a, 802.11n (20MHz) 5 for 802.11n (40MHz)
OUTPUT POWER	34.4mW for 5180 ~ 5240MHz 34.4mW for 5260 ~ 5320MHz 33.6mW for 5500 ~ 5700MHz
ANTENNA TYPE	PIFA antenna with 4dBi gain
ANTENNA CONNECTOR	NA
DATA CABLE	2.1m non-shielded RJ45 cable without core 2.1m non-shielded USB cable without core
I/O PORTS	Refer to user's manual
ACCESSORY DEVICES	NA

NOTE:

1. The frequency bands used in this EUT are listed as follows:

Frequency Band (MHz)	2412~2462	5180~5320	5500~5700	5745~5825
802.11b	√	-	-	-
802.11g	√	-	-	-
802.11a	-	√	√	√
802.11n (20MHz)	√	√	√	√
802.11n (40MHz)	√	√	√	√

2. The EUT provides two completed transmitters and two receivers.

MODULATION MODE	TX FUNCTION
802.11b	1TX
802.11g	1TX
802.11a	1TX
802.11n (20MHz) (MCS 0-7)	1TX
802.11n (20MHz) (MCS 8-15)	2TX
802.11n (40MHz) (MCS 0-7)	1TX
802.11n (40MHz) (MCS 8-15)	2TX

3. The above EUT information is declared by manufacturer and for more detailed features description, please refer to the manufacturer's specifications or user's manual.

3.2 DESCRIPTION OF TEST MODES

FOR 5180 ~ 5320MHz

8 channels are provided for 802.11a, 802.11n (20MHz):

CHANNEL	FREQUENCY	CHANNEL	FREQUENCY
36	5180 MHz	52	5260 MHz
40	5200 MHz	56	5280 MHz
44	5220 MHz	60	5300 MHz
48	5240 MHz	64	5320 MHz

4 channels are provided for 802.11n (40MHz):

CHANNEL	FREQUENCY	CHANNEL	FREQUENCY
38	5190 MHz	54	5270 MHz
46	5230 MHz	62	5310 MHz

FOR 5500 ~ 5700MHz

11 channels are provided for 802.11a, 802.11n (20MHz):

CHANNEL	FREQUENCY	CHANNEL	FREQUENCY
100	5500MHz	124	5620MHz
104	5520MHz	128	5640MHz
108	5540MHz	132	5660MHz
112	5560MHz	136	5680MHz
116	5580MHz	140	5700MHz
120	5600MHz		

5 channels are provided for 802.11n (40MHz):

CHANNEL	FREQUENCY	CHANNEL	FREQUENCY
102	5510MHz	126	5630MHz
110	5550MHz	134	5670MHz
118	5590MHz		

3.2.1 CONFIGURATION OF SYSTEM UNDER TEST

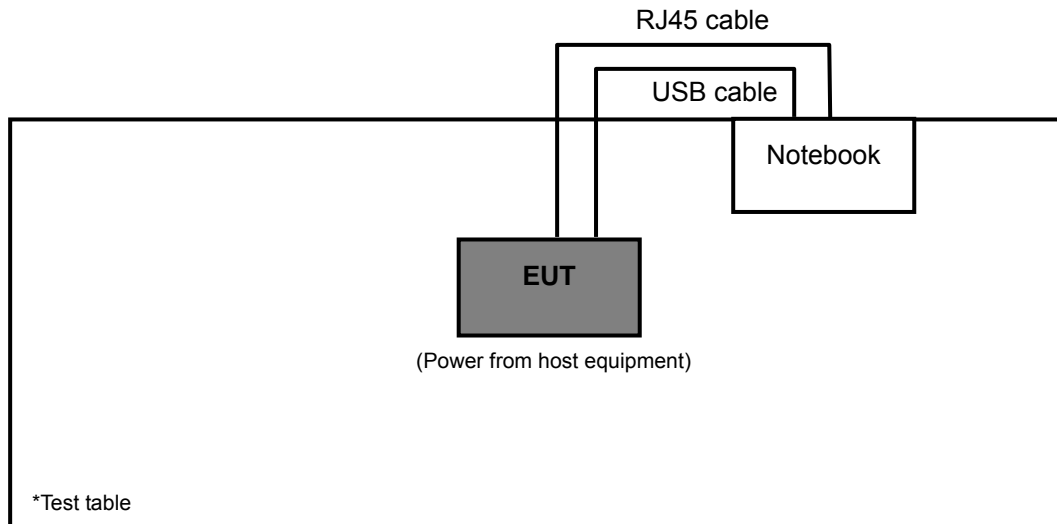



3.2.2 TEST MODE APPLICABILITY AND TESTED CHANNEL DETAIL

EUT CONFIGURE MODE	APPLICABLE TO				DESCRIPTION
	RE≥1G	RE<1G	PLC	APCM	
-	√	√	√	√	-

Where **RE≥1G**: Radiated Emission above 1GHz **RE<1G**: Radiated Emission below 1GHz
PLC: Power Line Conducted Emission **APCM**: Antenna Port Conducted Measurement

RADIATED EMISSION TEST (ABOVE 1GHz):

- Pre-Scan has been conducted to determine the worst-case mode from all possible combinations between available modulations and antenna ports (if EUT with antenna diversity architecture).
- Following channel(s) was (were) selected for the final test as listed below.

MODE	FREQ. BAND (MHz)	AVAILABLE CHANNEL	TESTED CHANNEL	MODULATION TECHNOLOGY	MODULATION TYPE	DATA RATE (Mbps)
802.11a	5180-5320	36 to 64	36, 40, 48, 52, 60, 64	OFDM	BPSK	6.0
802.11n (20MHz)		36 to 64	36, 40, 48, 52, 60, 64	OFDM	BPSK	13.0
802.11n (40MHz)		38 to 62	38, 46, 54, 62	OFDM	BPSK	27.0
802.11a	5500-5700	100 to 140	100, 116, 132, 140	OFDM	BPSK	6.0
802.11n (20MHz)		100 to 140	100, 116, 132, 140	OFDM	BPSK	13.0
802.11n (40MHz)		102 to 134	102, 110, 134	OFDM	BPSK	27.0

RADIATED EMISSION TEST (BELOW 1GHz):

- Pre-Scan has been conducted to determine the worst-case mode from all possible combinations between available modulations, data rates and antenna ports (if EUT with antenna diversity architecture).
- Following channel(s) was (were) selected for the final test as listed below.

MODE	FREQ. BAND (MHz)	AVAILABLE CHANNEL	TESTED CHANNEL	MODULATION TECHNOLOGY	MODULATION TYPE	DATA RATE (Mbps)
802.11n (20MHz)	5180-5320	36 to 64	36	OFDM	BPSK	13.0
802.11n (20MHz)	5500-5700	100 to 140	100	OFDM	BPSK	13.0

POWER LINE CONDUCTED EMISSION TEST:

- Pre-Scan has been conducted to determine the worst-case mode from all possible combinations between available modulations, data rates and antenna ports (if EUT with antenna diversity architecture).
- Following channel(s) was (were) selected for the final test as listed below.

MODE	FREQ. BAND (MHz)	AVAILABLE CHANNEL	TESTED CHANNEL	MODULATION TECHNOLOGY	MODULATION TYPE	DATA RATE (Mbps)
802.11n (20MHz)	5180-5320	36 to 64	36	OFDM	BPSK	13.0
802.11n (20MHz)	5500-5700	100 to 140	100	OFDM	BPSK	13.0

BANDEDGE MEASUREMENT:

- Pre-Scan has been conducted to determine the worst-case mode from all possible combinations between available modulations, data rates and antenna ports (if EUT with antenna diversity architecture).
- Following channel(s) was (were) selected for the final test as listed below.

MODE	FREQ. BAND (MHz)	AVAILABLE CHANNEL	TESTED CHANNEL	MODULATION TECHNOLOGY	MODULATION TYPE	DATA RATE (Mbps)
802.11a	5180-5320	36 to 64	36, 48, 52, 64	OFDM	BPSK	6.0
802.11n (20MHz)		36 to 64	36, 48, 52, 64	OFDM	BPSK	13.0
802.11n (40MHz)		38 to 62	38, 46, 54, 62	OFDM	BPSK	27.0
802.11a	5500-5700	100 to 140	100, 140	OFDM	BPSK	6.0
802.11n (20MHz)		100 to 140	100, 140	OFDM	BPSK	13.0
802.11n (40MHz)		102 to 134	102, 134	OFDM	BPSK	27.0

ANTENNA PORT CONDUCTED MEASUREMENT:

- This item includes all test value of each mode, but only includes spectrum plot of worst value of each mode.
- Pre-Scan has been conducted to determine the worst-case mode from all possible combinations between available modulations, data rates and antenna ports (if EUT with antenna diversity architecture).
- Following channel(s) was (were) selected for the final test as listed below.

MODE	FREQ. BAND (MHz)	AVAILABLE CHANNEL	TESTED CHANNEL	MODULATION TECHNOLOGY	MODULATION TYPE	DATA RATE (Mbps)
802.11a	5180-5320	36 to 64	36, 40, 48, 52, 60, 64	OFDM	BPSK	6.0
802.11n (20MHz)		36 to 64	36, 40, 48, 52, 60, 64	OFDM	BPSK	13.0
802.11n (40MHz)		38 to 62	38, 46, 54, 62	OFDM	BPSK	27.0
802.11a	5500-5700	100 to 140	100, 116, 132, 140	OFDM	BPSK	6.0
802.11n (20MHz)		100 to 140	100, 116, 132, 140	OFDM	BPSK	13.0
802.11n (40MHz)		102 to 134	102, 110, 134	OFDM	BPSK	27.0

TEST CONDITION:

APPLICABLE TO	ENVIRONMENTAL CONDITIONS	INPUT POWER (SYSTEM)	TESTED BY
RE \geq 1G	25deg. C, 68%RH	120Vac, 60Hz	Brad Wu
RE $<$ 1G	25deg. C, 65%RH	120Vac, 60Hz	Anderson Hong
PLC	25deg. C, 65%RH	120Vac, 60Hz	Anderson Hong
APCM	25deg. C, 68%RH	120Vac, 60Hz	Brad Wu

3.3 GENERAL DESCRIPTION OF APPLIED STANDARDS

The EUT is a RF Product. According to the specifications of the manufacturer, it must comply with the requirements of the following standards:

FCC Part 15, Subpart E (15.407)

ANSI C63.4-2003

ANSI C63.10-2009

All test items have been performed and recorded as per the above standards.

NOTE: The EUT is also considered as a kind of computer peripheral, because the connection to computer is necessary for typical use. It has been verified to comply with the requirements of FCC Part 15, Subpart B, Class B (DoC). The test report has been issued separately.

3.4 DESCRIPTION OF SUPPORT UNITS

The EUT has been tested as an independent unit together with other necessary accessories or support units. The following support units or accessories were used to form a representative test configuration during the tests.

NO.	PRODUCT	BRAND	MODEL NO.	SERIAL NO.	FCC ID
1	NOTEBOOK	DELL	D531	CN-0XM006-48643-81U-2973	QDS-BRCM1020

NO.	SIGNAL CABLE DESCRIPTION OF THE ABOVE SUPPORT UNITS
1	NA

NOTE: All power cords of the above support units are non shielded (1.8m).

4. TEST TYPES AND RESULTS

4.1 RADIATED EMISSION AND BANDEDGE MEASUREMENT

4.1.1 LIMITS OF RADIATED EMISSION AND BANDEDGE MEASUREMENT

Emissions radiated outside of the specified bands, shall be according to the general radiated limits in 15.209 as following:

FREQUENCIES (MHz)	FIELD STRENGTH (microvolts/meter)	MEASUREMENT DISTANCE (meters)
0.009 ~ 0.490	2400/F(kHz)	300
0.490 ~ 1.705	24000/F(kHz)	30
1.705 ~ 30.0	30	30
30 ~ 88	100	3
88 ~ 216	150	3
216 ~ 960	200	3
Above 960	500	3

NOTE:

1. The lower limit shall apply at the transition frequencies.
2. Emission level (dBuV/m) = 20 log Emission level (uV/m).
3. As shown in 15.35(b), for frequencies above 1000MHz, the field strength limits are based on average detector, however, the peak field strength of any emission shall not exceed the maximum permitted average limits, specified above by more than 20dB under any condition of modulation.

4.1.2 LIMITS OF UNWANTED EMISSION OUT OF THE RESTRICTED BANDS

FREQUENCIES (MHz)	EIRP LIMIT (dBm)	EQUIVALENT FIELD STRENGTH AT 3m (dBµV/m) *NOTE 3
	PK	PK
5150 ~ 5350	-27	68.3
5470 ~ 5725	-27	68.3

NOTE: The following formula is used to convert the equipment isotropic radiated power (eirp) to field strength:

$$E = \frac{1000000\sqrt{30P}}{3} \mu\text{V/m, where P is the eirp (Watts).}$$

4.1.3 TEST INSTRUMENTS

DESCRIPTION & MANUFACTURER	MODEL NO.	SERIAL NO.	DATE OF CALIBRATION	DUE DATE OF CALIBRATION
Test Receiver ROHDE & SCHWARZ	ESCI	100744	Apr. 19, 2011	Apr. 18, 2012
Spectrum Analyzer ROHDE & SCHWARZ	FSP40	100269	Jan. 06, 2011	Jan. 05, 2012
BILOG Antenna SCHWARZBECK	VULB9168	9168-156	Apr. 12, 2011	Apr. 11, 2012
HORN Antenna SCHWARZBECK	BBHA 9120 D	9120D-563	Sep. 06, 2011	Sep. 05, 2012
HORN Antenna SCHWARZBECK	BBHA 9170	BBHA9170243	Dec. 27, 2010	Dec. 26, 2011
Preamplifier Agilent	8449B	3008A01911	Oct. 29, 2011	Oct. 28, 2012
Preamplifier Agilent	8447D	2944A10638	Oct. 29, 2011	Oct. 28, 2012
RF signal cable HUBER+SUHNNER	SUCOFLEX 104	295013/4 283403/4	Aug. 19, 2011	Aug. 18, 2012
RF signal cable Worken	8D-FB	Cable-HYCH9-01	Aug. 13, 2011	Aug. 12, 2012
Software	ADT_Radiated_ V7.6.15.9.2	NA	NA	NA
Antenna Tower EMCO	2070/2080	512.835.4684	NA	NA
Turn Table EMCO	2087-2.03	NA	NA	NA
Antenna Tower & Turn Table Controller EMCO	2090	NA	NA	NA
High Speed Peak Power Meter	ML2495A	0824011	Aug. 04, 2011	Aug. 03, 2012
Power Sensor	MA2411B	0738171	Aug. 04, 2011	Aug. 03, 2012
26GHz ~ 40GHz Amplifier	EM26400	815221	Oct. 29, 2011	Oct. 28, 2012

- NOTE:**
1. The calibration interval of the above test instruments is 12 months and the calibrations are traceable to NML/ROC and NIST/USA.
 2. The test was performed in HwaYa Chamber 9.
 3. The horn antenna and HP preamplifier (model: 8449B) are used only for the measurement of emission frequency above 1GHz if tested.
 4. The FCC Site Registration No. is 460141.
 5. The IC Site Registration No. is IC 7450F-4.

4.1.4 TEST PROCEDURES

- a. The EUT was placed on the top of a rotating table 0.8 meters above the ground at a 3 meter semi-anechoic chamber. The table was rotated 360 degrees to determine the position of the highest radiation.
- b. The EUT was set 3 meters away from the interference-receiving antenna, which was mounted on the top of a variable-height antenna tower.
- c. The antenna is a broadband antenna, and its height is varied from one meter to four meters above the ground to determine the maximum value of the field strength. Both horizontal and vertical polarizations of the antenna are set to make the measurement.
- d. For each suspected emission, the EUT was arranged to its worst case and then the antenna was tuned to heights from 1 meter to 4 meters and the rotatable table was turned from 0 degrees to 360 degrees to find the maximum reading.
- e. The test-receiver system was set to Peak Detect Function and Specified Bandwidth with Maximum Hold Mode.
- f. If the emission level of the EUT in peak mode was 10dB lower than the limit specified, then testing could be stopped and the peak values of the EUT would be reported. Otherwise the emissions that did not have 10dB margin would be re-tested one by one using peak, quasi-peak or average method as specified and then reported in a data sheet.

NOTE:

1. The resolution bandwidth and video bandwidth of test receiver/spectrum analyzer is 120kHz for Peak detection (PK) and Quasi-peak detection (QP) at frequency below 1GHz.
2. The resolution bandwidth of test receiver/spectrum analyzer is 1MHz and video bandwidth is 3MHz for Peak detection at frequency above 1GHz.
3. The resolution bandwidth of test receiver/spectrum analyzer is 1MHz and the video bandwidth is 10Hz for Average detection (AV) at frequency above 1GHz.
4. All modes of operation were investigated and the worst-case emissions are reported.

4.1.5 DEVIATION FROM TEST STANDARD

No deviation.

4.1.6 TEST SETUP

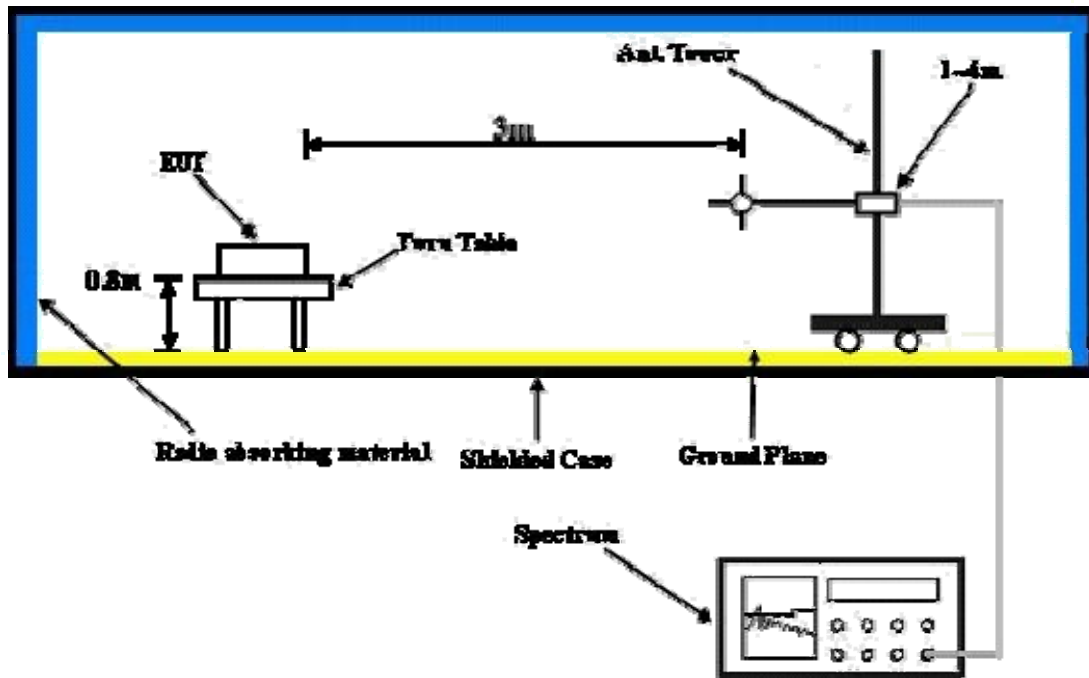

For the actual test configuration, please refer to the attached file (Test Setup Photo).

4.1.7 EUT OPERATING CONDITION

- Connected the EUT with notebook system via RJ45 & USB cable and placed on a testing table.
- The notebook system ran a test program (provided by manufacturer) to enable EUT under transmission condition continuously at specific channel frequency.
- The necessary accessories enable the system in full functions.

4.1.8 TEST RESULTS

ABOVE 1GHz WORST-CASE DATA: 802.11a

EUT TEST CONDITION		MEASUREMENT DETAIL	
CHANNEL	Channel 36	FREQUENCY RANGE	1 ~ 40GHz
INPUT POWER (SYSTEM)	120Vac, 60 Hz	DETECTOR FUNCTION	Peak (PK) Average (AV)
ENVIRONMENTAL CONDITIONS	25deg. C, 68%RH	TESTED BY	Brad Wu

ANTENNA POLARITY & TEST DISTANCE: HORIZONTAL AT 3 M								
NO.	FREQ. (MHz)	EMISSION LEVEL (dBuV/m)	LIMIT (dBuV/m)	MARGIN (dB)	ANTENNA HEIGHT (m)	TABLE ANGLE (Degree)	RAW VALUE (dBuV)	CORRECTION FACTOR (dB/m)
1	5150.00	63.3 PK	74.0	-10.7	1.28 H	194	24.90	38.40
2	5150.00	42.6 AV	54.0	-11.4	1.28 H	194	4.20	38.40
3	*5180.00	102.4 PK			1.28 H	194	64.00	38.40
4	*5180.00	93.0 AV			1.28 H	194	54.60	38.40
5	#10360.00	56.2 PK	68.3	-12.1	1.06 H	12	7.90	48.30
ANTENNA POLARITY & TEST DISTANCE: VERTICAL AT 3 M								
NO.	FREQ. (MHz)	EMISSION LEVEL (dBuV/m)	LIMIT (dBuV/m)	MARGIN (dB)	ANTENNA HEIGHT (m)	TABLE ANGLE (Degree)	RAW VALUE (dBuV)	CORRECTION FACTOR (dB/m)
1	5150.00	59.1 PK	74.0	-14.9	1.00 V	356	20.70	38.40
2	5150.00	41.1 AV	54.0	-12.9	1.00 V	356	2.70	38.40
3	*5180.00	100.4 PK			1.00 V	356	62.00	38.40
4	*5180.00	90.9 AV			1.00 V	356	52.50	38.40
5	#10360.00	55.3 PK	68.3	-13.0	1.05 V	112	7.00	48.30

- REMARKS:**
1. Emission level (dBuV/m) = Raw Value (dBuV) + Correction Factor (dB/m).
 2. Correction Factor (dB/m) = Antenna Factor (dB/m) + Cable Factor (dB).
 3. The other emission levels were very low against the limit.
 4. Margin value = Emission level – Limit value.
 5. “ * “: Fundamental frequency.
 6. “#”:The radiated frequency is out the restricted band.

EUT TEST CONDITION		MEASUREMENT DETAIL	
CHANNEL	Channel 40	FREQUENCY RANGE	1 ~ 40GHz
INPUT POWER (SYSTEM)	120Vac, 60 Hz	DETECTOR FUNCTION	Peak (PK) Average (AV)
ENVIRONMENTAL CONDITIONS	25deg. C, 68%RH	TESTED BY	Brad Wu

ANTENNA POLARITY & TEST DISTANCE: HORIZONTAL AT 3 M								
NO.	FREQ. (MHz)	EMISSION LEVEL (dBuV/m)	LIMIT (dBuV/m)	MARGIN (dB)	ANTENNA HEIGHT (m)	TABLE ANGLE (Degree)	RAW VALUE (dBuV)	CORRECTION FACTOR (dB/m)
1	5150.00	55.9 PK	74.0	-18.1	1.28 H	52	17.50	38.40
2	5150.00	38.1 AV	54.0	-15.9	1.28 H	52	-0.30	38.40
3	*5200.00	102.9 PK			1.28 H	52	64.50	38.40
4	*5200.00	93.4 AV			1.28 H	52	55.00	38.40
5	#10400.00	56.3 PK	68.3	-12.0	1.05 H	10	7.90	48.40
ANTENNA POLARITY & TEST DISTANCE: VERTICAL AT 3 M								
NO.	FREQ. (MHz)	EMISSION LEVEL (dBuV/m)	LIMIT (dBuV/m)	MARGIN (dB)	ANTENNA HEIGHT (m)	TABLE ANGLE (Degree)	RAW VALUE (dBuV)	CORRECTION FACTOR (dB/m)
1	5150.00	51.1 PK	74.0	-22.9	1.00 V	358	12.70	38.40
2	5150.00	35.8 AV	54.0	-18.2	1.00 V	358	-2.60	38.40
3	*5200.00	100.9 PK			1.00 V	358	62.50	38.40
4	*5200.00	91.3 AV			1.00 V	358	52.90	38.40
5	#10400.00	55.9 PK	68.3	-12.4	1.05 V	113	7.50	48.40

- REMARKS:**
1. Emission level (dBuV/m) = Raw Value (dBuV) + Correction Factor (dB/m).
 2. Correction Factor (dB/m) = Antenna Factor (dB/m) + Cable Factor (dB).
 3. The other emission levels were very low against the limit.
 4. Margin value = Emission level – Limit value.
 5. “ * “: Fundamental frequency.
 6. “#”:The radiated frequency is out the restricted band.



A D T

EUT TEST CONDITION		MEASUREMENT DETAIL	
CHANNEL	Channel 48	FREQUENCY RANGE	1 ~ 40GHz
INPUT POWER (SYSTEM)	120Vac, 60 Hz	DETECTOR FUNCTION	Peak (PK) Average (AV)
ENVIRONMENTAL CONDITIONS	25deg. C, 68%RH	TESTED BY	Brad Wu

ANTENNA POLARITY & TEST DISTANCE: HORIZONTAL AT 3 M								
NO.	FREQ. (MHz)	EMISSION LEVEL (dBuV/m)	LIMIT (dBuV/m)	MARGIN (dB)	ANTENNA HEIGHT (m)	TABLE ANGLE (Degree)	RAW VALUE (dBuV)	CORRECTION FACTOR (dB/m)
1	*5240.00	103.0 PK			1.24 H	50	64.50	38.50
2	*5240.00	93.7 AV			1.24 H	50	55.20	38.50
3	5350.00	46.5 PK	74.0	-27.5	1.24 H	50	7.80	38.70
4	5350.00	35.2 AV	54.0	-18.8	1.24 H	50	-3.50	38.70
5	#10480.00	56.2 PK	68.3	-12.1	1.05 H	11	7.70	48.50
ANTENNA POLARITY & TEST DISTANCE: VERTICAL AT 3 M								
NO.	FREQ. (MHz)	EMISSION LEVEL (dBuV/m)	LIMIT (dBuV/m)	MARGIN (dB)	ANTENNA HEIGHT (m)	TABLE ANGLE (Degree)	RAW VALUE (dBuV)	CORRECTION FACTOR (dB/m)
1	*5240.00	100.3 PK			1.00 V	11	61.80	38.50
2	*5240.00	91.0 AV			1.00 V	11	52.50	38.50
3	5350.00	45.8 PK	74.0	-28.2	1.00 V	11	7.10	38.70
4	5350.00	33.6 AV	54.0	-20.4	1.00 V	11	-5.10	38.70
5	#10480.00	55.8 PK	68.3	-12.5	1.05 V	113	7.30	48.50

- REMARKS:**
1. Emission level (dBuV/m) = Raw Value (dBuV) + Correction Factor (dB/m).
 2. Correction Factor (dB/m) = Antenna Factor (dB/m) + Cable Factor (dB).
 3. The other emission levels were very low against the limit.
 4. Margin value = Emission level – Limit value.
 5. “ * “: Fundamental frequency.
 6. “#”: The radiated frequency is out the restricted band.



A D T

EUT TEST CONDITION		MEASUREMENT DETAIL	
CHANNEL	Channel 52	FREQUENCY RANGE	1 ~ 40GHz
INPUT POWER (SYSTEM)	120Vac, 60 Hz	DETECTOR FUNCTION	Peak (PK) Average (AV)
ENVIRONMENTAL CONDITIONS	25deg. C, 68%RH	TESTED BY	Brad Wu

ANTENNA POLARITY & TEST DISTANCE: HORIZONTAL AT 3 M								
NO.	FREQ. (MHz)	EMISSION LEVEL (dBuV/m)	LIMIT (dBuV/m)	MARGIN (dB)	ANTENNA HEIGHT (m)	TABLE ANGLE (Degree)	RAW VALUE (dBuV)	CORRECTION FACTOR (dB/m)
1	5150.00	46.8 PK	74.0	-27.2	1.25 H	49	8.40	38.40
2	5150.00	34.8 AV	54.0	-19.2	1.25 H	49	-3.60	38.40
3	*5260.00	104.7 PK			1.25 H	49	66.20	38.50
4	*5260.00	95.0 AV			1.25 H	49	56.50	38.50
5	#10520.00	56.1 PK	68.3	-12.2	1.05 H	12	7.60	48.50
ANTENNA POLARITY & TEST DISTANCE: VERTICAL AT 3 M								
NO.	FREQ. (MHz)	EMISSION LEVEL (dBuV/m)	LIMIT (dBuV/m)	MARGIN (dB)	ANTENNA HEIGHT (m)	TABLE ANGLE (Degree)	RAW VALUE (dBuV)	CORRECTION FACTOR (dB/m)
1	5150.00	45.6 PK	74.0	-28.4	1.00 V	12	7.20	38.40
2	5150.00	33.9 AV	54.0	-20.1	1.00 V	12	-4.50	38.40
3	*5260.00	101.5 PK			1.00 V	12	63.00	38.50
4	*5260.00	91.9 AV			1.00 V	12	53.40	38.50
5	#10520.00	55.7 PK	68.3	-12.6	1.05 V	113	7.20	48.50

- REMARKS:**
1. Emission level (dBuV/m) = Raw Value (dBuV) + Correction Factor (dB/m).
 2. Correction Factor (dB/m) = Antenna Factor (dB/m) + Cable Factor (dB).
 3. The other emission levels were very low against the limit.
 4. Margin value = Emission level – Limit value.
 5. “ * “: Fundamental frequency.
 6. “#”: The radiated frequency is out the restricted band.



A D T

EUT TEST CONDITION		MEASUREMENT DETAIL	
CHANNEL	Channel 60	FREQUENCY RANGE	1 ~ 40GHz
INPUT POWER (SYSTEM)	120Vac, 60 Hz	DETECTOR FUNCTION	Peak (PK) Average (AV)
ENVIRONMENTAL CONDITIONS	25deg. C, 68%RH	TESTED BY	Brad Wu

ANTENNA POLARITY & TEST DISTANCE: HORIZONTAL AT 3 M								
NO.	FREQ. (MHz)	EMISSION LEVEL (dBuV/m)	LIMIT (dBuV/m)	MARGIN (dB)	ANTENNA HEIGHT (m)	TABLE ANGLE (Degree)	RAW VALUE (dBuV)	CORRECTION FACTOR (dB/m)
1	*5300.00	104.2 PK			1.23 H	49	65.60	38.60
2	*5300.00	94.8 AV			1.23 H	49	56.20	38.60
3	5350.00	56.2 PK	74.0	-17.8	1.23 H	49	17.50	38.70
4	5350.00	40.3 AV	54.0	-13.7	1.23 H	49	1.60	38.70
5	10600.00	56.4 PK	74.0	-17.6	1.05 H	12	7.70	48.70
6	10600.00	42.7 AV	54.0	-11.3	1.05 H	12	-6.00	48.70
ANTENNA POLARITY & TEST DISTANCE: VERTICAL AT 3 M								
NO.	FREQ. (MHz)	EMISSION LEVEL (dBuV/m)	LIMIT (dBuV/m)	MARGIN (dB)	ANTENNA HEIGHT (m)	TABLE ANGLE (Degree)	RAW VALUE (dBuV)	CORRECTION FACTOR (dB/m)
1	*5300.00	100.9 PK			1.10 V	13	62.30	38.60
2	*5300.00	91.4 AV			1.10 V	13	52.80	38.60
3	5350.00	51.9 PK	74.0	-22.1	1.10 V	13	13.20	38.70
4	5350.00	37.7 AV	54.0	-16.3	1.10 V	13	-1.00	38.70
5	10600.00	56.0 PK	74.0	-18.0	1.05 V	113	7.30	48.70
6	10600.00	42.1 AV	54.0	-11.9	1.05 V	113	-6.60	48.70

- REMARKS:**
1. Emission level (dBuV/m) = Raw Value (dBuV) + Correction Factor (dB/m).
 2. Correction Factor (dB/m) = Antenna Factor (dB/m) + Cable Factor (dB).
 3. The other emission levels were very low against the limit.
 4. Margin value = Emission level – Limit value.
 5. “ * “: Fundamental frequency.



A D T

EUT TEST CONDITION		MEASUREMENT DETAIL	
CHANNEL	Channel 64	FREQUENCY RANGE	1 ~ 40GHz
INPUT POWER (SYSTEM)	120Vac, 60 Hz	DETECTOR FUNCTION	Peak (PK) Average (AV)
ENVIRONMENTAL CONDITIONS	25deg. C, 68%RH	TESTED BY	Brad Wu

ANTENNA POLARITY & TEST DISTANCE: HORIZONTAL AT 3 M								
NO.	FREQ. (MHz)	EMISSION LEVEL (dBuV/m)	LIMIT (dBuV/m)	MARGIN (dB)	ANTENNA HEIGHT (m)	TABLE ANGLE (Degree)	RAW VALUE (dBuV)	CORRECTION FACTOR (dB/m)
1	*5320.00	104.9 PK			1.24 H	50	66.30	38.60
2	*5320.00	95.1 AV			1.24 H	50	56.50	38.60
3	5350.00	64.6 PK	74.0	-9.4	1.24 H	50	25.90	38.70
4	5350.00	50.5 AV	54.0	-3.5	1.24 H	50	11.80	38.70
5	10640.00	57.3 PK	74.0	-16.7	1.07 H	14	8.50	48.80
6	10640.00	43.1 AV	54.0	-10.9	1.07 H	14	-5.70	48.80
ANTENNA POLARITY & TEST DISTANCE: VERTICAL AT 3 M								
NO.	FREQ. (MHz)	EMISSION LEVEL (dBuV/m)	LIMIT (dBuV/m)	MARGIN (dB)	ANTENNA HEIGHT (m)	TABLE ANGLE (Degree)	RAW VALUE (dBuV)	CORRECTION FACTOR (dB/m)
1	*5320.00	100.9 PK			1.00 V	14	62.30	38.60
2	*5320.00	91.5 AV			1.00 V	14	52.90	38.60
3	5350.00	58.1 PK	74.0	-15.9	1.00 V	14	19.40	38.70
4	5350.00	44.1 AV	54.0	-9.9	1.00 V	14	5.40	38.70
5	10640.00	56.5 PK	74.0	-17.5	1.03 V	114	7.70	48.80
6	10640.00	43.0 AV	54.0	-11.0	1.03 V	114	-5.80	48.80

- REMARKS:**
1. Emission level (dBuV/m) = Raw Value (dBuV) + Correction Factor (dB/m).
 2. Correction Factor (dB/m) = Antenna Factor (dB/m) + Cable Factor (dB).
 3. The other emission levels were very low against the limit.
 4. Margin value = Emission level – Limit value.
 5. “ * “: Fundamental frequency.



A D T

EUT TEST CONDITION		MEASUREMENT DETAIL	
CHANNEL	Channel 100	FREQUENCY RANGE	1 ~ 40GHz
INPUT POWER (SYSTEM)	120Vac, 60 Hz	DETECTOR FUNCTION	Peak (PK) Average (AV)
ENVIRONMENTAL CONDITIONS	25deg. C, 68%RH	TESTED BY	Brad Wu

ANTENNA POLARITY & TEST DISTANCE: HORIZONTAL AT 3 M								
NO.	FREQ. (MHz)	EMISSION LEVEL (dBuV/m)	LIMIT (dBuV/m)	MARGIN (dB)	ANTENNA HEIGHT (m)	TABLE ANGLE (Degree)	RAW VALUE (dBuV)	CORRECTION FACTOR (dB/m)
1	5460.00	63.6 PK	74.0	-10.4	1.31 H	51	24.70	38.90
2	5460.00	47.7 AV	54.0	-6.3	1.31 H	51	8.80	38.90
3	#5470.00	67.3 PK	68.3	-1.0	1.31 H	51	28.40	38.90
4	*5500.00	106.1 PK			1.31 H	51	67.10	39.00
5	*5500.00	96.6 AV			1.31 H	51	57.60	39.00
6	11000.00	63.5 PK	74.0	-10.5	1.24 H	260	13.90	49.60
7	11000.00	49.4 AV	54.0	-4.6	1.24 H	260	-0.20	49.60

ANTENNA POLARITY & TEST DISTANCE: VERTICAL AT 3 M								
NO.	FREQ. (MHz)	EMISSION LEVEL (dBuV/m)	LIMIT (dBuV/m)	MARGIN (dB)	ANTENNA HEIGHT (m)	TABLE ANGLE (Degree)	RAW VALUE (dBuV)	CORRECTION FACTOR (dB/m)
1	5460.00	60.1 PK	74.0	-13.9	1.00 V	156	21.20	38.90
2	5460.00	44.3 AV	54.0	-9.7	1.00 V	156	5.40	38.90
3	#5470.00	64.8 PK	68.3	-3.5	1.00 V	156	25.90	38.90
4	*5500.00	103.3 PK			1.00 V	156	64.30	39.00
5	*5500.00	93.9 AV			1.00 V	156	54.90	39.00
6	11000.00	61.7 PK	74.0	-12.3	1.00 V	213	12.10	49.60
7	11000.00	48.1 AV	54.0	-5.9	1.00 V	213	-1.50	49.60

- REMARKS:**
1. Emission level (dBuV/m) = Raw Value (dBuV) + Correction Factor (dB/m).
 2. Correction Factor (dB/m) = Antenna Factor (dB/m) + Cable Factor (dB).
 3. The other emission levels were very low against the limit.
 4. Margin value = Emission level – Limit value.
 5. “ * “: Fundamental frequency.
 6. “#”:The radiated frequency is out the restricted band.



A D T

EUT TEST CONDITION		MEASUREMENT DETAIL	
CHANNEL	Channel 116	FREQUENCY RANGE	1 ~ 40GHz
INPUT POWER (SYSTEM)	120Vac, 60 Hz	DETECTOR FUNCTION	Peak (PK) Average (AV)
ENVIRONMENTAL CONDITIONS	25deg. C, 68%RH	TESTED BY	Brad Wu

ANTENNA POLARITY & TEST DISTANCE: HORIZONTAL AT 3 M								
NO.	FREQ. (MHz)	EMISSION LEVEL (dBuV/m)	LIMIT (dBuV/m)	MARGIN (dB)	ANTENNA HEIGHT (m)	TABLE ANGLE (Degree)	RAW VALUE (dBuV)	CORRECTION FACTOR (dB/m)
1	5470.00	49.6 PK	68.3	-18.7	1.29 H	57	10.70	38.90
2	*5580.00	109.6 PK			1.29 H	57	70.50	39.10
3	*5580.00	100.0 AV			1.29 H	57	60.90	39.10
4	11160.00	66.5 PK	74.0	-7.5	1.23 H	269	16.90	49.60
5	11160.00	53.0 AV	54.0	-1.0	1.23 H	269	3.40	49.60
ANTENNA POLARITY & TEST DISTANCE: VERTICAL AT 3 M								
NO.	FREQ. (MHz)	EMISSION LEVEL (dBuV/m)	LIMIT (dBuV/m)	MARGIN (dB)	ANTENNA HEIGHT (m)	TABLE ANGLE (Degree)	RAW VALUE (dBuV)	CORRECTION FACTOR (dB/m)
1	5470.00	47.8 PK	68.3	-20.5	1.00 V	161	8.90	38.90
2	*5580.00	105.5 PK			1.00 V	161	66.40	39.10
3	*5580.00	95.8 AV			1.00 V	161	56.70	39.10
4	11160.00	63.8 PK	74.0	-10.2	1.04 V	220	14.20	49.60
5	11160.00	50.2 AV	54.0	-3.8	1.04 V	220	0.60	49.60

- REMARKS:**
1. Emission level (dBuV/m) = Raw Value (dBuV) + Correction Factor (dB/m).
 2. Correction Factor (dB/m) = Antenna Factor (dB/m) + Cable Factor (dB).
 3. The other emission levels were very low against the limit.
 6. "#":The radiated frequency is out the restricted band.
 4. Margin value = Emission level – Limit value.



A D T

EUT TEST CONDITION		MEASUREMENT DETAIL	
CHANNEL	Channel 132	FREQUENCY RANGE	1 ~ 40GHz
INPUT POWER (SYSTEM)	120Vac, 60 Hz	DETECTOR FUNCTION	Peak (PK) Average (AV)
ENVIRONMENTAL CONDITIONS	25deg. C, 68%RH	TESTED BY	Brad Wu

ANTENNA POLARITY & TEST DISTANCE: HORIZONTAL AT 3 M								
NO.	FREQ. (MHz)	EMISSION LEVEL (dBuV/m)	LIMIT (dBuV/m)	MARGIN (dB)	ANTENNA HEIGHT (m)	TABLE ANGLE (Degree)	RAW VALUE (dBuV)	CORRECTION FACTOR (dB/m)
1	*5660.00	107.7 PK			1.27 H	56	67.70	39.30
2	*5660.00	97.2 AV			1.27 H	56	58.00	39.30
3	#5725.00	56.4 PK	68.3	-12.0	1.27 H	56	16.90	39.40
4	11320.00	65.5 PK	74.0	-6.2	1.20 H	268	18.10	49.70
5	11320.00	52.5 AV	54.0	-1.0	1.20 H	268	3.30	49.70
ANTENNA POLARITY & TEST DISTANCE: VERTICAL AT 3 M								
NO.	FREQ. (MHz)	EMISSION LEVEL (dBuV/m)	LIMIT (dBuV/m)	MARGIN (dB)	ANTENNA HEIGHT (m)	TABLE ANGLE (Degree)	RAW VALUE (dBuV)	CORRECTION FACTOR (dB/m)
1	*5660.00	104.8 PK			1.00 V	23	65.10	39.30
2	*5660.00	94.5 AV			1.00 V	23	55.20	39.30
3	#5725.00	53.7 PK	68.3	-13.8	1.00 V	23	15.10	39.40
4	11320.00	63.6 PK	74.0	-9.9	1.36 V	223	14.40	49.70
5	11320.00	50.1 AV	54.0	-3.5	1.36 V	223	0.80	49.70

- REMARKS:**
1. Emission level (dBuV/m) = Raw Value (dBuV) + Correction Factor (dB/m).
 2. Correction Factor (dB/m) = Antenna Factor (dB/m) + Cable Factor (dB).
 3. The other emission levels were very low against the limit.
 4. Margin value = Emission level – Limit value.
 5. “ * “: Fundamental frequency.
 6. "#":The radiated frequency is out the restricted band.



A D T

EUT TEST CONDITION		MEASUREMENT DETAIL	
CHANNEL	Channel 140	FREQUENCY RANGE	1 ~ 40GHz
INPUT POWER (SYSTEM)	120Vac, 60 Hz	DETECTOR FUNCTION	Peak (PK) Average (AV)
ENVIRONMENTAL CONDITIONS	25deg. C, 68%RH	TESTED BY	Brad Wu

ANTENNA POLARITY & TEST DISTANCE: HORIZONTAL AT 3 M								
NO.	FREQ. (MHz)	EMISSION LEVEL (dBuV/m)	LIMIT (dBuV/m)	MARGIN (dB)	ANTENNA HEIGHT (m)	TABLE ANGLE (Degree)	RAW VALUE (dBuV)	CORRECTION FACTOR (dB/m)
1	*5700.00	103.6 PK			1.26 H	64	64.20	39.40
2	*5700.00	94.2 AV			1.26 H	64	54.80	39.40
3	#5725.00	67.1 PK	68.3	-1.2	1.26 H	64	27.70	39.40
4	11400.00	64.6 PK	74.0	-9.4	1.19 H	265	15.00	49.60
5	11400.00	51.2 AV	54.0	-2.8	1.19 H	265	1.60	49.60
ANTENNA POLARITY & TEST DISTANCE: VERTICAL AT 3 M								
NO.	FREQ. (MHz)	EMISSION LEVEL (dBuV/m)	LIMIT (dBuV/m)	MARGIN (dB)	ANTENNA HEIGHT (m)	TABLE ANGLE (Degree)	RAW VALUE (dBuV)	CORRECTION FACTOR (dB/m)
1	*5700.00	101.4 PK			1.00 V	23	62.00	39.40
2	*5700.00	92.0 AV			1.00 V	23	52.60	39.40
3	#5725.00	65.3 PK	68.3	-3.0	1.00 V	23	25.90	39.40
4	11400.00	60.6 PK	74.0	-13.4	1.29 V	202	11.00	49.60
5	11400.00	47.5 AV	54.0	-6.5	1.29 V	202	-2.10	49.60

- REMARKS:**
1. Emission level (dBuV/m) = Raw Value (dBuV) + Correction Factor (dB/m).
 2. Correction Factor (dB/m) = Antenna Factor (dB/m) + Cable Factor (dB).
 3. The other emission levels were very low against the limit.
 4. Margin value = Emission level – Limit value.
 5. “ * “: Fundamental frequency.
 6. “#”:The radiated frequency is out the restricted band.

802.11n (20MHz)

EUT TEST CONDITION		MEASUREMENT DETAIL	
CHANNEL	Channel 36	FREQUENCY RANGE	1 ~ 40GHz
INPUT POWER (SYSTEM)	120Vac, 60 Hz	DETECTOR FUNCTION	Peak (PK) Average (AV)
ENVIRONMENTAL CONDITIONS	25deg. C, 68%RH	TESTED BY	Brad Wu

ANTENNA POLARITY & TEST DISTANCE: HORIZONTAL AT 3 M								
NO.	FREQ. (MHz)	EMISSION LEVEL (dBuV/m)	LIMIT (dBuV/m)	MARGIN (dB)	ANTENNA HEIGHT (m)	TABLE ANGLE (Degree)	RAW VALUE (dBuV)	CORRECTION FACTOR (dB/m)
1	5150.00	50.8 PK	74.0	-23.2	1.31 H	36	12.40	38.40
2	5150.00	38.8 AV	54.0	-15.2	1.31 H	36	0.40	38.40
3	*5180.00	102.1 PK			1.31 H	36	63.70	38.40
4	*5180.00	90.8 AV			1.31 H	36	52.40	38.40
5	#10360.00	64.0 PK	68.3	-4.3	1.45 H	112	15.70	48.30
ANTENNA POLARITY & TEST DISTANCE: VERTICAL AT 3 M								
NO.	FREQ. (MHz)	EMISSION LEVEL (dBuV/m)	LIMIT (dBuV/m)	MARGIN (dB)	ANTENNA HEIGHT (m)	TABLE ANGLE (Degree)	RAW VALUE (dBuV)	CORRECTION FACTOR (dB/m)
1	5150.00	48.7 PK	74.0	-25.3	1.00 V	23	10.30	38.40
2	5150.00	36.0 AV	54.0	-18.0	1.00 V	23	-2.40	38.40
3	*5180.00	100.1 PK			1.00 V	23	61.70	38.40
4	*5180.00	88.6 AV			1.00 V	23	50.20	38.40
5	#10360.00	62.3 PK	68.3	-6.0	1.36 V	154	14.00	48.30

- REMARKS:**
1. Emission level (dBuV/m) = Raw Value (dBuV) + Correction Factor (dB/m).
 2. Correction Factor (dB/m) = Antenna Factor (dB/m) + Cable Factor (dB).
 3. The other emission levels were very low against the limit.
 4. Margin value = Emission level – Limit value.
 5. “ * “: Fundamental frequency.
 6. “#”: The radiated frequency is out the restricted band.



A D T

EUT TEST CONDITION		MEASUREMENT DETAIL	
CHANNEL	Channel 40	FREQUENCY RANGE	1 ~ 40GHz
INPUT POWER (SYSTEM)	120Vac, 60 Hz	DETECTOR FUNCTION	Peak (PK) Average (AV)
ENVIRONMENTAL CONDITIONS	25deg. C, 68%RH	TESTED BY	Brad Wu

ANTENNA POLARITY & TEST DISTANCE: HORIZONTAL AT 3 M								
NO.	FREQ. (MHz)	EMISSION LEVEL (dBuV/m)	LIMIT (dBuV/m)	MARGIN (dB)	ANTENNA HEIGHT (m)	TABLE ANGLE (Degree)	RAW VALUE (dBuV)	CORRECTION FACTOR (dB/m)
1	5150.00	48.7 PK	74.0	-25.3	1.27 H	327	10.30	38.40
2	5150.00	36.0 AV	54.0	-18.0	1.27 H	327	-2.40	38.40
3	*5200.00	103.5 PK			1.27 H	327	65.10	38.40
4	*5200.00	91.5 AV			1.27 H	327	53.10	38.40
5	#10400.00	64.3 PK	68.3	-4.0	1.57 H	99	15.90	48.40
ANTENNA POLARITY & TEST DISTANCE: VERTICAL AT 3 M								
NO.	FREQ. (MHz)	EMISSION LEVEL (dBuV/m)	LIMIT (dBuV/m)	MARGIN (dB)	ANTENNA HEIGHT (m)	TABLE ANGLE (Degree)	RAW VALUE (dBuV)	CORRECTION FACTOR (dB/m)
1	5150.00	46.5 PK	74.0	-27.5	1.00 V	18	8.10	38.40
2	5150.00	34.6 AV	54.0	-19.4	1.00 V	18	-3.80	38.40
3	*5200.00	99.8 PK			1.00 V	18	61.40	38.40
4	*5200.00	88.3 AV			1.00 V	18	49.90	38.40
5	#10400.00	61.8 PK	68.3	-6.5	1.43 V	139	13.40	48.40

- REMARKS:**
1. Emission level (dBuV/m) = Raw Value (dBuV) + Correction Factor (dB/m).
 2. Correction Factor (dB/m) = Antenna Factor (dB/m) + Cable Factor (dB).
 3. The other emission levels were very low against the limit.
 4. Margin value = Emission level – Limit value.
 5. “ * “: Fundamental frequency.
 6. “#“: The radiated frequency is out the restricted band.



A D T

EUT TEST CONDITION		MEASUREMENT DETAIL	
CHANNEL	Channel 48	FREQUENCY RANGE	1 ~ 40GHz
INPUT POWER (SYSTEM)	120Vac, 60 Hz	DETECTOR FUNCTION	Peak (PK) Average (AV)
ENVIRONMENTAL CONDITIONS	25deg. C, 68%RH	TESTED BY	Brad Wu

ANTENNA POLARITY & TEST DISTANCE: HORIZONTAL AT 3 M								
NO.	FREQ. (MHz)	EMISSION LEVEL (dBuV/m)	LIMIT (dBuV/m)	MARGIN (dB)	ANTENNA HEIGHT (m)	TABLE ANGLE (Degree)	RAW VALUE (dBuV)	CORRECTION FACTOR (dB/m)
1	*5240.00	103.8 PK			1.00 H	327	65.30	38.50
2	*5240.00	92.2 AV			1.00 H	327	53.70	38.50
3	5350.00	46.8 PK	74.0	-27.2	1.00 H	327	8.10	38.70
4	5350.00	35.3 AV	54.0	-18.7	1.00 H	327	-3.40	38.70
5	#10480.00	63.8 PK	68.3	-4.5	1.57 H	100	15.30	48.50
ANTENNA POLARITY & TEST DISTANCE: VERTICAL AT 3 M								
NO.	FREQ. (MHz)	EMISSION LEVEL (dBuV/m)	LIMIT (dBuV/m)	MARGIN (dB)	ANTENNA HEIGHT (m)	TABLE ANGLE (Degree)	RAW VALUE (dBuV)	CORRECTION FACTOR (dB/m)
1	*5240.00	100.0 PK			1.11 V	9	61.50	38.50
2	*5240.00	88.1 AV			1.11 V	9	49.60	38.50
3	5350.00	46.0 PK	74.0	-28.0	1.11 V	9	7.30	38.70
4	5350.00	32.9 AV	54.0	-21.1	1.11 V	9	-5.80	38.70
5	#10480.00	61.9 PK	68.3	-6.4	1.43 V	138	13.40	48.50

- REMARKS:**
1. Emission level (dBuV/m) = Raw Value (dBuV) + Correction Factor (dB/m).
 2. Correction Factor (dB/m) = Antenna Factor (dB/m) + Cable Factor (dB).
 3. The other emission levels were very low against the limit.
 4. Margin value = Emission level – Limit value.
 5. “ * “: Fundamental frequency.
 6. “#”:The radiated frequency is out the restricted band.



A D T

EUT TEST CONDITION		MEASUREMENT DETAIL	
CHANNEL	Channel 52	FREQUENCY RANGE	1 ~ 40GHz
INPUT POWER (SYSTEM)	120Vac, 60 Hz	DETECTOR FUNCTION	Peak (PK) Average (AV)
ENVIRONMENTAL CONDITIONS	25deg. C, 68%RH	TESTED BY	Brad Wu

ANTENNA POLARITY & TEST DISTANCE: HORIZONTAL AT 3 M								
NO.	FREQ. (MHz)	EMISSION LEVEL (dBuV/m)	LIMIT (dBuV/m)	MARGIN (dB)	ANTENNA HEIGHT (m)	TABLE ANGLE (Degree)	RAW VALUE (dBuV)	CORRECTION FACTOR (dB/m)
1	5150.00	46.2 PK	74.0	-27.8	1.00 H	325	7.80	38.40
2	5150.00	33.3 AV	54.0	-20.7	1.00 H	325	-5.10	38.40
3	*5260.00	103.4 PK			1.00 H	325	64.90	38.50
4	*5260.00	92.1 AV			1.00 H	325	53.60	38.50
5	#10520.00	63.2 PK	68.3	-5.1	1.56 H	99	14.70	48.50
ANTENNA POLARITY & TEST DISTANCE: VERTICAL AT 3 M								
NO.	FREQ. (MHz)	EMISSION LEVEL (dBuV/m)	LIMIT (dBuV/m)	MARGIN (dB)	ANTENNA HEIGHT (m)	TABLE ANGLE (Degree)	RAW VALUE (dBuV)	CORRECTION FACTOR (dB/m)
1	5150.00	44.6 PK	74.0	-29.4	1.10 V	9	6.20	38.40
2	5150.00	32.8 AV	54.0	-21.2	1.10 V	9	-5.60	38.40
3	*5260.00	100.0 PK			1.10 V	9	61.50	38.50
4	*5260.00	88.6 AV			1.10 V	9	50.10	38.50
5	#10360.00	61.4 PK	68.3	-6.9	1.56 V	138	13.10	48.30

- REMARKS:**
1. Emission level (dBuV/m) = Raw Value (dBuV) + Correction Factor (dB/m).
 2. Correction Factor (dB/m) = Antenna Factor (dB/m) + Cable Factor (dB).
 3. The other emission levels were very low against the limit.
 4. Margin value = Emission level – Limit value.
 5. “ * “: Fundamental frequency.
 6. “#“: The radiated frequency is out the restricted band.



A D T

EUT TEST CONDITION		MEASUREMENT DETAIL	
CHANNEL	Channel 60	FREQUENCY RANGE	1 ~ 40GHz
INPUT POWER (SYSTEM)	120Vac, 60 Hz	DETECTOR FUNCTION	Peak (PK) Average (AV)
ENVIRONMENTAL CONDITIONS	25deg. C, 68%RH	TESTED BY	Brad Wu

ANTENNA POLARITY & TEST DISTANCE: HORIZONTAL AT 3 M								
NO.	FREQ. (MHz)	EMISSION LEVEL (dBuV/m)	LIMIT (dBuV/m)	MARGIN (dB)	ANTENNA HEIGHT (m)	TABLE ANGLE (Degree)	RAW VALUE (dBuV)	CORRECTION FACTOR (dB/m)
1	*5300.00	105.1 PK			1.00 H	323	66.50	38.60
2	*5300.00	93.9 AV			1.00 H	323	55.30	38.60
3	5350.00	52.6 PK	74.0	-21.4	1.00 H	323	13.90	38.70
4	5350.00	38.2 AV	54.0	-15.8	1.00 H	323	-0.50	38.70
5	10600.00	63.5 PK	74.0	-10.5	1.55 H	99	14.80	48.70
6	10600.00	49.5 AV	54.0	-4.5	1.55 H	99	0.80	48.70
ANTENNA POLARITY & TEST DISTANCE: VERTICAL AT 3 M								
NO.	FREQ. (MHz)	EMISSION LEVEL (dBuV/m)	LIMIT (dBuV/m)	MARGIN (dB)	ANTENNA HEIGHT (m)	TABLE ANGLE (Degree)	RAW VALUE (dBuV)	CORRECTION FACTOR (dB/m)
1	*5300.00	101.3 PK			1.09 V	11	62.70	38.60
2	*5300.00	90.0 AV			1.09 V	11	51.40	38.60
3	5350.00	48.7 PK	74.0	-25.3	1.09 V	11	10.00	38.70
4	5350.00	35.7 AV	54.0	-18.3	1.09 V	11	-3.00	38.70
5	10600.00	61.0 PK	74.0	-13.0	1.40 V	139	12.30	48.70
6	10600.00	47.8 AV	54.0	-6.2	1.40 V	139	-0.90	48.70

- REMARKS:**
1. Emission level (dBuV/m) = Raw Value (dBuV) + Correction Factor (dB/m).
 2. Correction Factor (dB/m) = Antenna Factor (dB/m) + Cable Factor (dB).
 3. The other emission levels were very low against the limit.
 4. Margin value = Emission level – Limit value.
 5. “ * “: Fundamental frequency.



A D T

EUT TEST CONDITION		MEASUREMENT DETAIL	
CHANNEL	Channel 64	FREQUENCY RANGE	1 ~ 40GHz
INPUT POWER (SYSTEM)	120Vac, 60 Hz	DETECTOR FUNCTION	Peak (PK) Average (AV)
ENVIRONMENTAL CONDITIONS	25deg. C, 68%RH	TESTED BY	Brad Wu

ANTENNA POLARITY & TEST DISTANCE: HORIZONTAL AT 3 M								
NO.	FREQ. (MHz)	EMISSION LEVEL (dBuV/m)	LIMIT (dBuV/m)	MARGIN (dB)	ANTENNA HEIGHT (m)	TABLE ANGLE (Degree)	RAW VALUE (dBuV)	CORRECTION FACTOR (dB/m)
1	*5320.00	104.9 PK			1.00 H	326	66.30	38.60
2	*5320.00	93.2 AV			1.00 H	326	54.60	38.60
3	5350.00	60.9 PK	74.0	-13.1	1.00 H	326	22.20	38.70
4	5350.00	43.1 AV	54.0	-10.9	1.00 H	326	4.40	38.70
5	10640.00	62.0 PK	74.0	-12.0	1.56 H	94	13.20	48.80
6	10640.00	48.9 AV	54.0	-5.1	1.56 H	94	0.10	48.80
ANTENNA POLARITY & TEST DISTANCE: VERTICAL AT 3 M								
NO.	FREQ. (MHz)	EMISSION LEVEL (dBuV/m)	LIMIT (dBuV/m)	MARGIN (dB)	ANTENNA HEIGHT (m)	TABLE ANGLE (Degree)	RAW VALUE (dBuV)	CORRECTION FACTOR (dB/m)
1	*5320.00	101.2 PK			1.09 V	12	62.60	38.60
2	*5320.00	89.6 AV			1.09 V	12	51.00	38.60
3	5350.00	55.4 PK	74.0	-18.6	1.09 V	12	16.70	38.70
4	5350.00	40.5 AV	54.0	-13.5	1.09 V	12	1.80	38.70
5	10640.00	61.2 PK	74.0	-12.8	1.46 V	139	12.40	48.80
6	10640.00	47.2 AV	54.0	-6.8	1.46 V	139	-1.60	48.80

- REMARKS:**
1. Emission level (dBuV/m) = Raw Value (dBuV) + Correction Factor (dB/m).
 2. Correction Factor (dB/m) = Antenna Factor (dB/m) + Cable Factor (dB).
 3. The other emission levels were very low against the limit.
 4. Margin value = Emission level – Limit value.
 5. “ * “: Fundamental frequency.

EUT TEST CONDITION		MEASUREMENT DETAIL	
CHANNEL	Channel 100	FREQUENCY RANGE	1 ~ 40GHz
INPUT POWER (SYSTEM)	120Vac, 60 Hz	DETECTOR FUNCTION	Peak (PK) Average (AV)
ENVIRONMENTAL CONDITIONS	25deg. C, 68%RH	TESTED BY	Brad Wu

ANTENNA POLARITY & TEST DISTANCE: HORIZONTAL AT 3 M								
NO.	FREQ. (MHz)	EMISSION LEVEL (dBuV/m)	LIMIT (dBuV/m)	MARGIN (dB)	ANTENNA HEIGHT (m)	TABLE ANGLE (Degree)	RAW VALUE (dBuV)	CORRECTION FACTOR (dB/m)
1	5460.00	59.7 PK	74.0	-14.3	1.00 H	50	20.80	38.90
2	5460.00	42.4 AV	54.0	-11.6	1.00 H	50	3.50	38.90
3	#5470.00	63.7 PK	68.3	-4.6	1.00 H	50	24.80	38.90
4	*5500.00	105.6 PK			1.00 H	50	66.60	39.00
5	*5500.00	95.8 AV			1.00 H	50	56.80	39.00
6	11000.00	62.2 PK	74.0	-11.8	1.24 H	262	12.60	49.60
7	11000.00	49.1 AV	54.0	-4.9	1.24 H	262	-0.50	49.60

ANTENNA POLARITY & TEST DISTANCE: VERTICAL AT 3 M								
NO.	FREQ. (MHz)	EMISSION LEVEL (dBuV/m)	LIMIT (dBuV/m)	MARGIN (dB)	ANTENNA HEIGHT (m)	TABLE ANGLE (Degree)	RAW VALUE (dBuV)	CORRECTION FACTOR (dB/m)
1	5460.00	54.4 PK	74.0	-19.6	1.11 V	157	15.50	38.90
2	5460.00	39.1 AV	54.0	-14.9	1.11 V	157	0.20	38.90
3	#5470.00	58.2 PK	68.3	-10.1	1.11 V	157	19.30	38.90
4	*5500.00	102.1 PK			1.11 V	157	63.10	39.00
5	*5500.00	91.7 AV			1.11 V	157	52.70	39.00
6	11000.00	60.7 PK	74.0	-13.3	1.10 V	29	11.10	49.60
7	11000.00	47.6 AV	54.0	-6.4	1.10 V	29	-2.00	49.60

- REMARKS:**
1. Emission level (dBuV/m) = Raw Value (dBuV) + Correction Factor (dB/m).
 2. Correction Factor (dB/m) = Antenna Factor (dB/m) + Cable Factor (dB).
 3. The other emission levels were very low against the limit.
 4. Margin value = Emission level – Limit value.
 5. “ * “: Fundamental frequency.
 6. “#”: The radiated frequency is out the restricted band.



A D T

EUT TEST CONDITION		MEASUREMENT DETAIL	
CHANNEL	Channel 116	FREQUENCY RANGE	1 ~ 40GHz
INPUT POWER (SYSTEM)	120Vac, 60 Hz	DETECTOR FUNCTION	Peak (PK) Average (AV)
ENVIRONMENTAL CONDITIONS	25deg. C, 68%RH	TESTED BY	Brad Wu

ANTENNA POLARITY & TEST DISTANCE: HORIZONTAL AT 3 M								
NO.	FREQ. (MHz)	EMISSION LEVEL (dBuV/m)	LIMIT (dBuV/m)	MARGIN (dB)	ANTENNA HEIGHT (m)	TABLE ANGLE (Degree)	RAW VALUE (dBuV)	CORRECTION FACTOR (dB/m)
1	5470.00	47.3 PK	68.3	-21.0	1.00 H	50	8.40	38.90
2	*5580.00	106.7 PK			1.00 H	50	67.60	39.10
3	*5580.00	96.6 AV			1.00 H	50	57.50	39.10
4	11160.00	65.2 PK	74.0	-8.8	1.23 H	262	15.60	49.60
5	11160.00	52.3 AV	54.0	-1.7	1.23 H	262	2.70	49.60
ANTENNA POLARITY & TEST DISTANCE: VERTICAL AT 3 M								
NO.	FREQ. (MHz)	EMISSION LEVEL (dBuV/m)	LIMIT (dBuV/m)	MARGIN (dB)	ANTENNA HEIGHT (m)	TABLE ANGLE (Degree)	RAW VALUE (dBuV)	CORRECTION FACTOR (dB/m)
1	5470.00	45.7 PK	68.3	-22.6	1.09 V	157	6.80	38.90
2	*5580.00	103.4 PK			1.09 V	157	64.30	39.10
3	*5580.00	93.0 AV			1.09 V	157	53.90	39.10
4	11160.00	62.6 PK	74.0	-11.4	1.06 V	46	13.00	49.60
5	11160.00	49.1 AV	54.0	-4.9	1.06 V	46	-0.50	49.60

- REMARKS:**
1. Emission level (dBuV/m) = Raw Value (dBuV) + Correction Factor (dB/m).
 2. Correction Factor (dB/m) = Antenna Factor (dB/m) + Cable Factor (dB).
 3. The other emission levels were very low against the limit.
 4. Margin value = Emission level – Limit value.
 5. “ * “: Fundamental frequency.



A D T

EUT TEST CONDITION		MEASUREMENT DETAIL	
CHANNEL	Channel 132	FREQUENCY RANGE	1 ~ 40GHz
INPUT POWER (SYSTEM)	120Vac, 60 Hz	DETECTOR FUNCTION	Peak (PK) Average (AV)
ENVIRONMENTAL CONDITIONS	25deg. C, 68%RH	TESTED BY	Brad Wu

ANTENNA POLARITY & TEST DISTANCE: HORIZONTAL AT 3 M								
NO.	FREQ. (MHz)	EMISSION LEVEL (dBuV/m)	LIMIT (dBuV/m)	MARGIN (dB)	ANTENNA HEIGHT (m)	TABLE ANGLE (Degree)	RAW VALUE (dBuV)	CORRECTION FACTOR (dB/m)
1	*5660.00	107.7 PK			1.00 H	61	68.40	39.30
2	*5660.00	97.2 AV			1.00 H	61	57.90	39.30
3	#5725.00	56.4 PK	68.3	-11.9	1.00 H	61	17.00	39.40
4	11320.00	65.5 PK	74.0	-8.5	1.21 H	262	15.80	49.70
5	11320.00	52.5 AV	54.0	-1.5	1.21 H	262	2.80	49.70
ANTENNA POLARITY & TEST DISTANCE: VERTICAL AT 3 M								
NO.	FREQ. (MHz)	EMISSION LEVEL (dBuV/m)	LIMIT (dBuV/m)	MARGIN (dB)	ANTENNA HEIGHT (m)	TABLE ANGLE (Degree)	RAW VALUE (dBuV)	CORRECTION FACTOR (dB/m)
1	*5660.00	104.8 PK			1.00 V	109	65.50	39.30
2	*5660.00	94.5 AV			1.00 V	109	55.20	39.30
3	#5725.00	53.7 PK	68.3	-14.6	1.00 V	109	14.30	39.40
4	11320.00	63.6 PK	74.0	-10.4	1.06 V	29	13.90	49.70
5	11320.00	50.1 AV	54.0	-3.9	1.06 V	29	0.40	49.70

- REMARKS:**
1. Emission level (dBuV/m) = Raw Value (dBuV) + Correction Factor (dB/m).
 2. Correction Factor (dB/m) = Antenna Factor (dB/m) + Cable Factor (dB).
 3. The other emission levels were very low against the limit.
 4. Margin value = Emission level – Limit value.
 5. “ * “: Fundamental frequency.
 6. “#”:The radiated frequency is out the restricted band.



A D T

EUT TEST CONDITION		MEASUREMENT DETAIL	
CHANNEL	Channel 140	FREQUENCY RANGE	1 ~ 40GHz
INPUT POWER (SYSTEM)	120Vac, 60 Hz	DETECTOR FUNCTION	Peak (PK) Average (AV)
ENVIRONMENTAL CONDITIONS	25deg. C, 68%RH	TESTED BY	Brad Wu

ANTENNA POLARITY & TEST DISTANCE: HORIZONTAL AT 3 M								
NO.	FREQ. (MHz)	EMISSION LEVEL (dBuV/m)	LIMIT (dBuV/m)	MARGIN (dB)	ANTENNA HEIGHT (m)	TABLE ANGLE (Degree)	RAW VALUE (dBuV)	CORRECTION FACTOR (dB/m)
1	*5700.00	106.0 PK			1.30 H	61	66.60	39.40
2	*5700.00	95.3 AV			1.30 H	61	55.90	39.40
3	#5725.00	67.3 PK	68.3	-1.0	1.30 H	61	27.90	39.40
4	11400.00	63.6 PK	74.0	-10.4	1.22 H	262	14.00	49.60
5	11400.00	50.5 AV	54.0	-3.5	1.22 H	262	0.90	49.60
ANTENNA POLARITY & TEST DISTANCE: VERTICAL AT 3 M								
NO.	FREQ. (MHz)	EMISSION LEVEL (dBuV/m)	LIMIT (dBuV/m)	MARGIN (dB)	ANTENNA HEIGHT (m)	TABLE ANGLE (Degree)	RAW VALUE (dBuV)	CORRECTION FACTOR (dB/m)
1	*5700.00	102.7 PK			1.13 V	108	63.30	39.40
2	*5700.00	92.2 AV			1.13 V	108	52.80	39.40
3	#5725.00	63.9 PK	68.3	-4.4	1.13 V	108	24.50	39.40
4	11400.00	62.0 PK	74.0	-12.0	1.04 V	30	12.40	49.60
5	11400.00	48.4 AV	54.0	-5.6	1.04 V	30	-1.20	49.60

- REMARKS:**
1. Emission level (dBuV/m) = Raw Value (dBuV) + Correction Factor (dB/m).
 2. Correction Factor (dB/m) = Antenna Factor (dB/m) + Cable Factor (dB).
 3. The other emission levels were very low against the limit.
 4. Margin value = Emission level – Limit value.
 5. “ * “: Fundamental frequency.
 6. "#":The radiated frequency is out the restricted band.



802.11n (40MHz)

EUT TEST CONDITION		MEASUREMENT DETAIL	
CHANNEL	Channel 38	FREQUENCY RANGE	1 ~ 40GHz
INPUT POWER (SYSTEM)	120Vac, 60 Hz	DETECTOR FUNCTION	Peak (PK) Average (AV)
ENVIRONMENTAL CONDITIONS	25deg. C, 68%RH	TESTED BY	Brad Wu

ANTENNA POLARITY & TEST DISTANCE: HORIZONTAL AT 3 M								
NO.	FREQ. (MHz)	EMISSION LEVEL (dBuV/m)	LIMIT (dBuV/m)	MARGIN (dB)	ANTENNA HEIGHT (m)	TABLE ANGLE (Degree)	RAW VALUE (dBuV)	CORRECTION FACTOR (dB/m)
1	5150.00	57.1 PK	74.0	-16.9	1.00 H	317	18.70	38.40
2	5150.00	41.7 AV	54.0	-12.3	1.00 H	317	3.30	38.40
3	*5190.00	99.7 PK			1.00 H	317	61.30	38.40
4	*5190.00	88.9 AV			1.00 H	317	50.50	38.40
5	#10380.00	60.9 PK	68.3	-7.4	1.58 H	96	12.60	48.30

ANTENNA POLARITY & TEST DISTANCE: VERTICAL AT 3 M								
NO.	FREQ. (MHz)	EMISSION LEVEL (dBuV/m)	LIMIT (dBuV/m)	MARGIN (dB)	ANTENNA HEIGHT (m)	TABLE ANGLE (Degree)	RAW VALUE (dBuV)	CORRECTION FACTOR (dB/m)
1	5150.00	55.8 PK	74.0	-18.2	1.17 V	227	17.40	38.40
2	5150.00	39.9 AV	54.0	-14.1	1.17 V	227	1.50	38.40
3	*5190.00	97.2 PK			1.17 V	227	58.80	38.40
4	*5190.00	85.7 AV			1.17 V	227	47.30	38.40
5	#10380.00	58.8 PK	68.3	-9.5	1.44 V	138	10.50	48.30

- REMARKS:**
1. Emission level (dBuV/m) = Raw Value (dBuV) + Correction Factor (dB/m).
 2. Correction Factor (dB/m) = Antenna Factor (dB/m) + Cable Factor (dB).
 3. The other emission levels were very low against the limit.
 4. Margin value = Emission level – Limit value.
 5. “ * “: Fundamental frequency.
 6. “#”: The radiated frequency is out the restricted band.



A D T

EUT TEST CONDITION		MEASUREMENT DETAIL	
CHANNEL	Channel 46	FREQUENCY RANGE	1 ~ 40GHz
INPUT POWER (SYSTEM)	120Vac, 60 Hz	DETECTOR FUNCTION	Peak (PK) Average (AV)
ENVIRONMENTAL CONDITIONS	25deg. C, 68%RH	TESTED BY	Brad Wu

ANTENNA POLARITY & TEST DISTANCE: HORIZONTAL AT 3 M								
NO.	FREQ. (MHz)	EMISSION LEVEL (dBuV/m)	LIMIT (dBuV/m)	MARGIN (dB)	ANTENNA HEIGHT (m)	TABLE ANGLE (Degree)	RAW VALUE (dBuV)	CORRECTION FACTOR (dB/m)
1	5150.00	47.8 PK	74.0	-26.2	1.00 H	326	9.40	38.40
2	5150.00	35.5 AV	54.0	-18.5	1.00 H	326	-2.90	38.40
3	*5230.00	101.0 PK			1.00 H	326	62.50	38.50
4	*5230.00	89.9 AV			1.00 H	326	51.40	38.50
5	#10460.00	61.0 PK	68.3	-7.3	1.57 H	101	12.50	48.50
ANTENNA POLARITY & TEST DISTANCE: VERTICAL AT 3 M								
NO.	FREQ. (MHz)	EMISSION LEVEL (dBuV/m)	LIMIT (dBuV/m)	MARGIN (dB)	ANTENNA HEIGHT (m)	TABLE ANGLE (Degree)	RAW VALUE (dBuV)	CORRECTION FACTOR (dB/m)
1	5150.00	45.9 PK	74.0	-28.1	1.20 V	224	7.50	38.40
2	5150.00	34.4 AV	54.0	-19.6	1.20 V	224	-4.00	38.40
3	*5230.00	98.0 PK			1.20 V	224	59.50	38.50
4	*5230.00	86.2 AV			1.20 V	224	47.70	38.50
5	#10460.00	58.6 PK	68.3	-9.7	1.56 V	134	10.10	48.50

- REMARKS:**
1. Emission level (dBuV/m) = Raw Value (dBuV) + Correction Factor (dB/m).
 2. Correction Factor (dB/m) = Antenna Factor (dB/m) + Cable Factor (dB).
 3. The other emission levels were very low against the limit.
 4. Margin value = Emission level – Limit value.
 5. “ * “: Fundamental frequency.
 6. “#”: The radiated frequency is out the restricted band.



A D T

EUT TEST CONDITION		MEASUREMENT DETAIL	
CHANNEL	Channel 54	FREQUENCY RANGE	1 ~ 40GHz
INPUT POWER (SYSTEM)	120Vac, 60 Hz	DETECTOR FUNCTION	Peak (PK) Average (AV)
ENVIRONMENTAL CONDITIONS	25deg. C, 68%RH	TESTED BY	Brad Wu

ANTENNA POLARITY & TEST DISTANCE: HORIZONTAL AT 3 M								
NO.	FREQ. (MHz)	EMISSION LEVEL (dBuV/m)	LIMIT (dBuV/m)	MARGIN (dB)	ANTENNA HEIGHT (m)	TABLE ANGLE (Degree)	RAW VALUE (dBuV)	CORRECTION FACTOR (dB/m)
1	5150.00	45.6 PK	74.0	-28.4	1.00 H	326	7.20	38.40
2	5150.00	33.9 AV	54.0	-20.1	1.00 H	326	-4.50	38.40
3	*5270.00	100.9 PK			1.00 H	326	62.30	38.60
4	*5270.00	89.8 AV			1.00 H	326	51.20	38.60
5	#10540.00	60.4 PK	68.3	-7.9	1.56 H	97	11.80	48.60
ANTENNA POLARITY & TEST DISTANCE: VERTICAL AT 3 M								
NO.	FREQ. (MHz)	EMISSION LEVEL (dBuV/m)	LIMIT (dBuV/m)	MARGIN (dB)	ANTENNA HEIGHT (m)	TABLE ANGLE (Degree)	RAW VALUE (dBuV)	CORRECTION FACTOR (dB/m)
1	5150.00	45.0 PK	74.0	-29.0	1.67 V	277	6.60	38.40
2	5150.00	33.2 AV	54.0	-20.8	1.67 V	277	-5.20	38.40
3	*5270.00	97.6 PK			1.67 V	277	59.00	38.60
4	*5270.00	86.1 AV			1.67 V	277	47.50	38.60
5	#10540.00	59.3 PK	68.3	-9.0	1.50 V	139	10.70	48.60

- REMARKS:**
1. Emission level (dBuV/m) = Raw Value (dBuV) + Correction Factor (dB/m).
 2. Correction Factor (dB/m) = Antenna Factor (dB/m) + Cable Factor (dB).
 3. The other emission levels were very low against the limit.
 4. Margin value = Emission level – Limit value.
 5. “ * “: Fundamental frequency.
 6. “#”: The radiated frequency is out the restricted band.



A D T

EUT TEST CONDITION		MEASUREMENT DETAIL	
CHANNEL	Channel 62	FREQUENCY RANGE	1 ~ 40GHz
INPUT POWER (SYSTEM)	120Vac, 60 Hz	DETECTOR FUNCTION	Peak (PK) Average (AV)
ENVIRONMENTAL CONDITIONS	25deg. C, 68%RH	TESTED BY	Brad Wu

ANTENNA POLARITY & TEST DISTANCE: HORIZONTAL AT 3 M								
NO.	FREQ. (MHz)	EMISSION LEVEL (dBuV/m)	LIMIT (dBuV/m)	MARGIN (dB)	ANTENNA HEIGHT (m)	TABLE ANGLE (Degree)	RAW VALUE (dBuV)	CORRECTION FACTOR (dB/m)
1	*5310.00	101.8 PK			1.00 H	326	63.20	38.60
2	*5310.00	90.6 AV			1.00 H	326	52.00	38.60
3	5350.00	64.1 PK	74.0	-9.9	1.00 H	326	25.40	38.70
4	5350.00	48.6 AV	54.0	-5.4	1.00 H	326	9.90	38.70
5	10620.00	60.7 PK	74.0	-13.3	1.55 H	96	12.00	48.70
6	10620.00	47.0 AV	54.0	-7.0	1.55 H	96	-1.70	48.70
ANTENNA POLARITY & TEST DISTANCE: VERTICAL AT 3 M								
NO.	FREQ. (MHz)	EMISSION LEVEL (dBuV/m)	LIMIT (dBuV/m)	MARGIN (dB)	ANTENNA HEIGHT (m)	TABLE ANGLE (Degree)	RAW VALUE (dBuV)	CORRECTION FACTOR (dB/m)
1	*5310.00	98.4 PK			1.65 V	277	59.80	38.60
2	*5310.00	86.8 AV			1.65 V	277	48.20	38.60
3	5350.00	59.5 PK	74.0	-14.5	1.65 V	277	20.80	38.70
4	5350.00	44.7 AV	54.0	-9.3	1.65 V	277	6.00	38.70
5	10620.00	58.3 PK	74.0	-15.7	1.53 V	137	9.60	48.70
6	10620.00	45.4 AV	54.0	-8.6	1.53 V	137	-3.30	48.70

- REMARKS:**
1. Emission level (dBuV/m) = Raw Value (dBuV) + Correction Factor (dB/m).
 2. Correction Factor (dB/m) = Antenna Factor (dB/m) + Cable Factor (dB).
 3. The other emission levels were very low against the limit.
 4. Margin value = Emission level – Limit value.
 5. “ * “: Fundamental frequency.

EUT TEST CONDITION		MEASUREMENT DETAIL	
CHANNEL	Channel 102	FREQUENCY RANGE	1 ~ 40GHz
INPUT POWER (SYSTEM)	120Vac, 60 Hz	DETECTOR FUNCTION	Peak (PK) Average (AV)
ENVIRONMENTAL CONDITIONS	25deg. C, 68%RH	TESTED BY	Brad Wu

ANTENNA POLARITY & TEST DISTANCE: HORIZONTAL AT 3 M								
NO.	FREQ. (MHz)	EMISSION LEVEL (dBuV/m)	LIMIT (dBuV/m)	MARGIN (dB)	ANTENNA HEIGHT (m)	TABLE ANGLE (Degree)	RAW VALUE (dBuV)	CORRECTION FACTOR (dB/m)
1	5460.00	61.5 PK	74.0	-12.5	1.20 H	325	22.60	38.90
2	5460.00	46.8 AV	54.0	-7.2	1.20 H	325	7.90	38.90
3	#5470.00	65.7 PK	68.3	-2.6	1.20 H	325	26.80	38.90
4	*5510.00	103.6 PK			1.20 H	325	64.60	39.00
5	*5510.00	92.1 AV			1.20 H	325	53.10	39.00
6	11020.00	61.0 PK	74.0	-13.0	1.24 H	264	11.40	49.60
7	11020.00	47.6 AV	54.0	-6.4	1.24 H	264	-2.00	49.60

ANTENNA POLARITY & TEST DISTANCE: VERTICAL AT 3 M								
NO.	FREQ. (MHz)	EMISSION LEVEL (dBuV/m)	LIMIT (dBuV/m)	MARGIN (dB)	ANTENNA HEIGHT (m)	TABLE ANGLE (Degree)	RAW VALUE (dBuV)	CORRECTION FACTOR (dB/m)
1	5460.00	59.7 PK	74.0	-14.3	1.57 V	273	20.80	38.90
2	5460.00	44.6 AV	54.0	-9.4	1.57 V	273	5.70	38.90
3	#5470.00	64.6 PK	68.3	-3.7	1.57 V	273	25.70	38.90
4	*5510.00	101.5 PK			1.57 V	273	62.50	39.00
5	*5510.00	90.5 AV			1.57 V	273	51.50	39.00
6	11020.00	60.0 PK	74.0	-14.0	1.34 V	193	10.40	49.60
7	11020.00	46.5 AV	54.0	-7.5	1.34 V	193	-3.10	49.60

- REMARKS:**
1. Emission level (dBuV/m) = Raw Value (dBuV) + Correction Factor (dB/m).
 2. Correction Factor (dB/m) = Antenna Factor (dB/m) + Cable Factor (dB).
 3. The other emission levels were very low against the limit.
 4. Margin value = Emission level – Limit value.
 5. “ * “: Fundamental frequency.
 6. “#”:The radiated frequency is out the restricted band.



A D T

EUT TEST CONDITION		MEASUREMENT DETAIL	
CHANNEL	Channel 110	FREQUENCY RANGE	1 ~ 40GHz
INPUT POWER (SYSTEM)	120Vac, 60 Hz	DETECTOR FUNCTION	Peak (PK) Average (AV)
ENVIRONMENTAL CONDITIONS	25deg. C, 68%RH	TESTED BY	Brad Wu

ANTENNA POLARITY & TEST DISTANCE: HORIZONTAL AT 3 M								
NO.	FREQ. (MHz)	EMISSION LEVEL (dBuV/m)	LIMIT (dBuV/m)	MARGIN (dB)	ANTENNA HEIGHT (m)	TABLE ANGLE (Degree)	RAW VALUE (dBuV)	CORRECTION FACTOR (dB/m)
1	5470.00	57.3 PK	68.3	-11.0	1.27 H	325	18.40	38.90
2	*5550.00	104.1 PK			1.27 H	325	65.10	39.00
3	*5550.00	92.8 AV			1.27 H	325	53.8	39.00
4	11100.00	61.3 PK	74.0	-12.7	1.23 H	263	11.70	49.60
5	11100.00	48.0 AV	54.0	-6.0	1.23 H	263	-1.60	49.60
ANTENNA POLARITY & TEST DISTANCE: VERTICAL AT 3 M								
NO.	FREQ. (MHz)	EMISSION LEVEL (dBuV/m)	LIMIT (dBuV/m)	MARGIN (dB)	ANTENNA HEIGHT (m)	TABLE ANGLE (Degree)	RAW VALUE (dBuV)	CORRECTION FACTOR (dB/m)
1	5470.00	53.3 PK	68.3	-15.0	1.57 V	273	14.40	38.90
2	*5550.00	101.9 PK			1.57 V	273	62.90	39.00
3	*5550.00	90.7 AV			1.57 V	273	51.70	39.00
4	11100.00	60.4 PK	74.0	-13.6	1.35 V	194	10.80	49.60
5	11100.00	46.8 AV	54.0	-7.2	1.35 V	194	-2.80	49.60

- REMARKS:**
1. Emission level (dBuV/m) = Raw Value (dBuV) + Correction Factor (dB/m).
 2. Correction Factor (dB/m) = Antenna Factor (dB/m) + Cable Factor (dB).
 3. The other emission levels were very low against the limit.
 4. Margin value = Emission level – Limit value.
 5. “ * “: Fundamental frequency.



A D T

EUT TEST CONDITION		MEASUREMENT DETAIL	
CHANNEL	Channel 134	FREQUENCY RANGE	1 ~ 40GHz
INPUT POWER (SYSTEM)	120Vac, 60 Hz	DETECTOR FUNCTION	Peak (PK) Average (AV)
ENVIRONMENTAL CONDITIONS	25deg. C, 68%RH	TESTED BY	Brad Wu

ANTENNA POLARITY & TEST DISTANCE: HORIZONTAL AT 3 M								
NO.	FREQ. (MHz)	EMISSION LEVEL (dBuV/m)	LIMIT (dBuV/m)	MARGIN (dB)	ANTENNA HEIGHT (m)	TABLE ANGLE (Degree)	RAW VALUE (dBuV)	CORRECTION FACTOR (dB/m)
1	*5670.00	104.4 PK			1.27 H	320	65.10	39.30
2	*5670.00	93.2 AV			1.27 H	320	53.90	39.30
3	#5725.00	64.8 PK	68.3	-3.5	1.27 H	320	25.40	39.40
4	11340.00	63.3 PK	74.0	-10.7	1.21 H	262	13.70	49.60
5	11340.00	49.7 AV	54.0	-4.3	1.21 H	262	0.10	49.60
ANTENNA POLARITY & TEST DISTANCE: VERTICAL AT 3 M								
NO.	FREQ. (MHz)	EMISSION LEVEL (dBuV/m)	LIMIT (dBuV/m)	MARGIN (dB)	ANTENNA HEIGHT (m)	TABLE ANGLE (Degree)	RAW VALUE (dBuV)	CORRECTION FACTOR (dB/m)
1	*5670.00	102.1 PK			1.24 V	359	62.80	39.30
2	*5670.00	91.5 AV			1.24 V	359	52.20	39.30
3	#5725.00	60.3 PK	68.3	-8.0	1.24 V	359	20.90	39.40
4	11340.00	60.3 PK	74.0	-13.7	1.16 V	194	10.70	49.60
5	11340.00	47.4 AV	54.0	-6.6	1.16 V	194	-2.20	49.60

- REMARKS:**
1. Emission level (dBuV/m) = Raw Value (dBuV) + Correction Factor (dB/m).
 2. Correction Factor (dB/m) = Antenna Factor (dB/m) + Cable Factor (dB).
 3. The other emission levels were very low against the limit.
 4. Margin value = Emission level – Limit value.
 5. “ * “: Fundamental frequency.
 6. “#”:The radiated frequency is out the restricted band.

BELOW 1GHz WORST-CASE DATA : 802.11a

EUT TEST CONDITION		MEASUREMENT DETAIL	
CHANNEL	Channel 36	FREQUENCY RANGE	Below 1000MHz
INPUT POWER (SYSTEM)	120Vac, 60 Hz	DETECTOR FUNCTION	Quasi-Peak
ENVIRONMENTAL CONDITIONS	25deg. C, 65%RH	TESTED BY	Anderson Hong

ANTENNA POLARITY & TEST DISTANCE: HORIZONTAL AT 3 M								
NO.	FREQ. (MHz)	EMISSION LEVEL (dBuV/m)	LIMIT (dBuV/m)	MARGIN (dB)	ANTENNA HEIGHT (m)	TABLE ANGLE (Degree)	RAW VALUE (dBuV)	CORRECTION FACTOR (dB/m)
1	105.73	31.1 QP	43.5	-12.4	1.50 H	76	21.80	9.30
2	136.84	31.8 QP	43.5	-11.7	1.25 H	295	18.30	13.50
3	249.60	42.6 QP	46.0	-3.4	1.25 H	238	30.00	12.60
4	469.31	30.6 QP	46.0	-15.4	1.50 H	55	11.80	18.80
5	632.63	31.6 QP	46.0	-14.4	1.25 H	301	9.10	22.50
6	799.84	38.3 QP	46.0	-7.7	1.25 H	322	13.90	24.40
ANTENNA POLARITY & TEST DISTANCE: VERTICAL AT 3 M								
NO.	FREQ. (MHz)	EMISSION LEVEL (dBuV/m)	LIMIT (dBuV/m)	MARGIN (dB)	ANTENNA HEIGHT (m)	TABLE ANGLE (Degree)	RAW VALUE (dBuV)	CORRECTION FACTOR (dB/m)
1	55.18	32.7 QP	40.0	-7.3	1.00 V	238	19.60	13.10
2	105.73	33.8 QP	43.5	-9.7	1.25 V	70	24.50	9.30
3	249.60	37.1 QP	46.0	-8.9	1.25 V	10	24.50	12.60
4	529.58	29.6 QP	46.0	-16.4	1.25 V	295	9.20	20.40
5	797.89	36.1 QP	46.0	-9.9	1.50 V	355	11.70	24.40
6	949.55	39.4 QP	46.0	-6.6	1.00 V	148	12.90	26.50

- REMARKS:**
1. Emission level (dBuV/m) = Raw Value (dBuV) + Correction Factor (dB/m).
 2. Correction Factor (dB/m) = Antenna Factor (dB/m) + Cable Factor (dB).
 3. The other emission levels were very low against the limit.
 4. Margin value = Emission level – Limit value.



A D T

EUT TEST CONDITION		MEASUREMENT DETAIL	
CHANNEL	Channel 100	FREQUENCY RANGE	Below 1000MHz
INPUT POWER (SYSTEM)	120Vac, 60 Hz	DETECTOR FUNCTION	Quasi-Peak
ENVIRONMENTAL CONDITIONS	25deg. C, 65%RH	TESTED BY	Anderson Hong

ANTENNA POLARITY & TEST DISTANCE: HORIZONTAL AT 3 M								
NO.	FREQ. (MHz)	EMISSION LEVEL (dBuV/m)	LIMIT (dBuV/m)	MARGIN (dB)	ANTENNA HEIGHT (m)	TABLE ANGLE (Degree)	RAW VALUE (dBuV)	CORRECTION FACTOR (dB/m)
1	105.73	30.3 QP	43.5	-13.2	1.50 H	82	21.00	9.30
2	138.78	31.1 QP	43.5	-12.4	1.25 H	286	17.30	13.80
3	249.60	42.8 QP	46.0	-3.2	1.25 H	235	30.20	12.60
4	632.63	33.9 QP	46.0	-12.1	1.25 H	289	11.40	22.50
5	795.95	34.2 QP	46.0	-11.8	2.00 H	343	9.80	24.40
6	947.60	34.7 QP	46.0	-11.3	1.00 H	253	8.20	26.50
ANTENNA POLARITY & TEST DISTANCE: VERTICAL AT 3 M								
NO.	FREQ. (MHz)	EMISSION LEVEL (dBuV/m)	LIMIT (dBuV/m)	MARGIN (dB)	ANTENNA HEIGHT (m)	TABLE ANGLE (Degree)	RAW VALUE (dBuV)	CORRECTION FACTOR (dB/m)
1	55.18	33.2 QP	40.0	-6.8	1.00 V	253	20.10	13.10
2	105.73	33.7 QP	43.5	-9.8	1.25 V	73	24.40	9.30
3	249.60	37.2 QP	46.0	-8.8	1.00 V	358	24.60	12.60
4	500.42	33.0 QP	46.0	-13.0	1.00 V	82	13.30	19.70
5	799.84	34.8 QP	46.0	-11.2	1.00 V	10	10.40	24.40
6	947.60	39.3 QP	46.0	-6.7	1.00 V	139	12.80	26.50

- REMARKS:**
1. Emission level (dBuV/m) = Raw Value (dBuV) + Correction Factor (dB/m).
 2. Correction Factor (dB/m) = Antenna Factor (dB/m) + Cable Factor (dB).
 3. The other emission levels were very low against the limit.
 4. Margin value = Emission level – Limit value.

4.2 CONDUCTED EMISSION MEASUREMENT

4.2.1 LIMITS OF CONDUCTED EMISSION MEASUREMENT

FREQUENCY OF EMISSION (MHz)	CONDUCTED LIMIT (dB μ V)	
	Quasi-peak	Average
0.15 ~ 0.5	66 to 56	56 to 46
0.5 ~ 5	56	46
5 ~ 30	60	50

- NOTE:** 1. The lower limit shall apply at the transition frequencies.
 2. The limit decreases in line with the logarithm of the frequency in the range of 0.15 to 0.50MHz.
 3. All emanations from a class A/B digital device or system, including any network of conductors and apparatus connected thereto, shall not exceed the level of field strengths specified above.

4.2.2 TEST INSTRUMENTS

DESCRIPTION & MANUFACTURER	MODEL NO.	SERIAL NO.	DATE OF CALIBRATION	DUE DATE OF CALIBRATION
Test Receiver ROHDE & SCHWARZ	ESCS30	100291	Nov. 23, 2011	Nov. 22, 2012
RF signal cable Woken	5D-FB	Cable-HYC01-01	Dec. 30, 2010	Dec. 29, 2011
LISN ROHDE & SCHWARZ	ESH3-Z5	100312	Jul. 07, 2011	Jul. 06, 2012
LISN ROHDE & SCHWARZ	ESH2-Z5	100100	Jan. 06, 2011	Jan. 05, 2012
LISN ROHDE & SCHWARZ	ESH3-Z5	835239/001	Feb. 22, 2011	Feb. 21, 2012
V-LISN SCHWARZBECK	NNBL 8226-2	8226-142	Jun. 30, 2011	Jun. 29, 2012
LISN ROHDE & SCHWARZ	ENV216	100072	Jun. 10, 2011	Jun. 09, 2012
Software ADT	ADT_Cond_ V7.3.7	NA	NA	NA

- NOTE:** 1. The calibration interval of the above test instruments is 12 months and the calibrations are traceable to NML/ROC and NIST/USA.
 2. The test was performed in HwaYa Shielded Room 1.
 3. The VCCI Site Registration No. is C-2040.

4.2.3 TEST PROCEDURES

- a. The EUT was placed 0.4 meters from the conducting wall of the shielded room with EUT being connected to the power mains through a line impedance stabilization network (LISN). Other support units were connected to the power mains through another LISN. The two LISNs provide 50 ohm/ 50uH of coupling impedance for the measuring instrument.
- b. Both lines of the power mains connected to the EUT were checked for maximum conducted interference.
- c. The frequency range from 150kHz to 30MHz was searched. Emission levels under (Limit - 20dB) was not recorded.

4.2.4 DEVIATION FROM TEST STANDARD

No deviation.

4.2.5 TEST SETUP

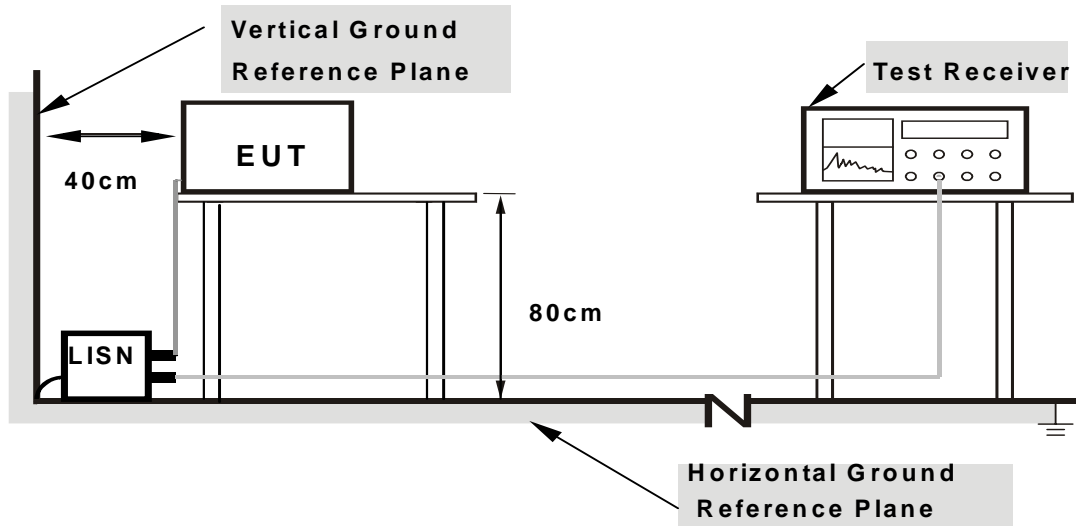

Note: 1. Support units were connected to second LISN.

2. Both of LISNs (AMN) are 80 cm from EUT and at least 80 from other units and other metal planes

For the actual test configuration, please refer to the attached file (Test Setup Photo).

4.2.6 EUT OPERATING CONDITIONS

Same as 4.1.6.

4.2.7 TEST RESULTS

CONDUCTED WORST-CASE DATA : 802.11n (20MHz)

CHANNEL	Channel 36	PHASE	Line 1
6dB BANDWIDTH	9kHz		

No	Freq. [MHz]	Corr. Factor (dB)	Reading Value		Emission Level		Limit		Margin	
			[dB (uV)]		[dB (uV)]		[dB (uV)]		(dB)	
			Q.P.	AV.	Q.P.	AV.	Q.P.	AV.	Q.P.	AV.
1	0.166	0.12	48.81	41.13	48.93	41.25	65.18	55.18	-16.25	-13.93
2	0.205	0.12	40.36	31.11	40.48	31.23	63.42	53.42	-22.94	-22.19
3	3.969	0.31	34.39	24.05	34.70	24.36	56.00	46.00	-21.30	-21.64
4	5.172	0.38	34.86	24.53	35.24	24.91	60.00	50.00	-24.76	-25.09
5	9.934	0.66	28.60	23.11	29.26	23.77	60.00	50.00	-30.74	-26.23
6	20.809	1.16	28.36	22.81	29.52	23.97	60.00	50.00	-30.48	-26.03

- REMARKS:**
1. Q.P. and AV. are abbreviations of quasi-peak and average individually.
 2. "-": The Quasi-peak reading value also meets average limit and measurement with the average detector is unnecessary.
 3. The emission levels of other frequencies were very low against the limit.
 4. Margin value = Emission level - Limit value
 5. Correction factor = Insertion loss + Cable loss
 6. Emission Level = Correction Factor + Reading Value.

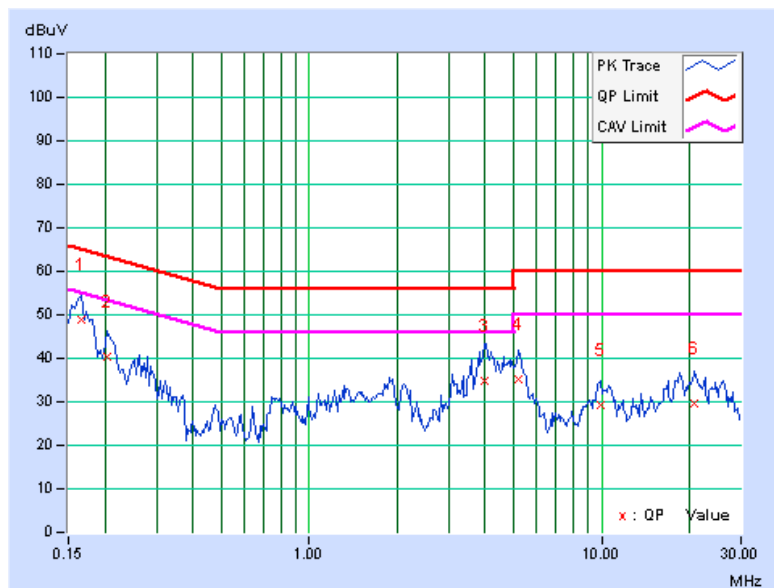

CHANNEL	Channel 36	PHASE	Line 2
6dB BANDWIDTH	9kHz		

No	Freq. [MHz]	Corr. Factor (dB)	Reading Value		Emission Level		Limit		Margin	
			[dB (uV)]		[dB (uV)]		[dB (uV)]		(dB)	
			Q.P.	AV.	Q.P.	AV.	Q.P.	AV.	Q.P.	AV.
1	0.154	0.13	43.89	25.66	44.02	25.79	65.79	55.79	-21.77	-30.00
2	0.170	0.13	51.06	41.14	51.19	41.27	64.98	54.98	-13.80	-13.72
3	3.621	0.30	34.40	23.04	34.70	23.34	56.00	46.00	-21.30	-22.66
4	4.090	0.32	39.48	27.17	39.80	27.49	56.00	46.00	-16.20	-18.51
5	9.934	0.61	30.37	24.00	30.98	24.61	60.00	50.00	-29.02	-25.39
6	20.555	0.94	28.09	21.87	29.03	22.81	60.00	50.00	-30.97	-27.19

- REMARKS:**
1. Q.P. and AV. are abbreviations of quasi-peak and average individually.
 2. "-": The Quasi-peak reading value also meets average limit and measurement with the average detector is unnecessary.
 3. The emission levels of other frequencies were very low against the limit.
 4. Margin value = Emission level - Limit value
 5. Correction factor = Insertion loss + Cable loss
 6. Emission Level = Correction Factor + Reading Value.

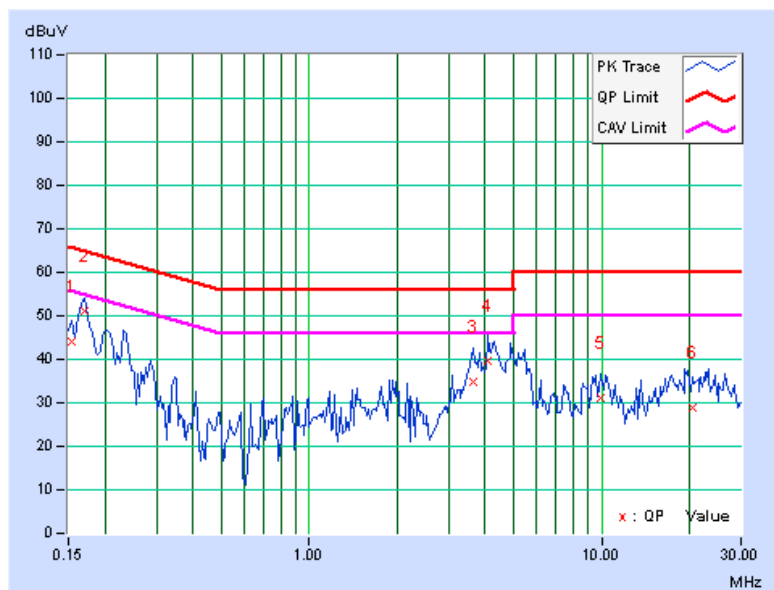

CHANNEL	Channel 100	PHASE	Line 1
6dB BANDWIDTH	9kHz		

No	Freq. [MHz]	Corr. Factor (dB)	Reading Value		Emission Level		Limit		Margin	
			[dB (uV)]		[dB (uV)]		[dB (uV)]		(dB)	
			Q.P.	AV.	Q.P.	AV.	Q.P.	AV.	Q.P.	AV.
1	0.166	0.12	48.39	41.13	48.51	41.25	65.18	55.18	-16.67	-13.93
2	0.199	0.12	37.73	27.31	37.85	27.43	63.64	53.64	-25.79	-26.21
3	3.895	0.30	34.09	24.05	34.39	24.35	56.00	46.00	-21.61	-21.65
4	5.176	0.38	34.59	24.42	34.97	24.80	60.00	50.00	-25.03	-25.20
5	10.301	0.67	28.71	23.44	29.38	24.11	60.00	50.00	-30.62	-25.89
6	20.785	1.16	28.10	22.44	29.26	23.60	60.00	50.00	-30.74	-26.40

- REMARKS:**
1. Q.P. and AV. are abbreviations of quasi-peak and average individually.
 2. "-": The Quasi-peak reading value also meets average limit and measurement with the average detector is unnecessary.
 3. The emission levels of other frequencies were very low against the limit.
 4. Margin value = Emission level - Limit value
 5. Correction factor = Insertion loss + Cable loss
 6. Emission Level = Correction Factor + Reading Value.

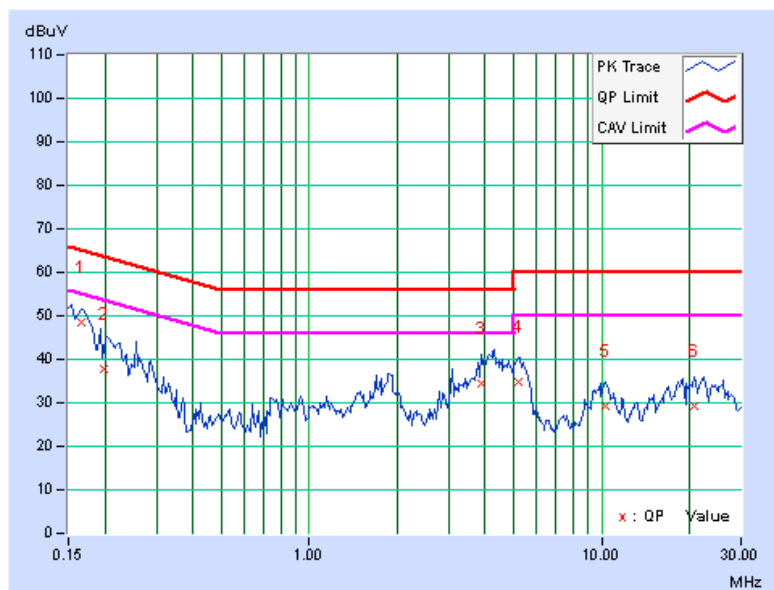



A D T

CHANNEL	Channel 100	PHASE	Line 2
6dB BANDWIDTH	9kHz		

No	Freq. [MHz]	Corr. Factor (dB)	Reading Value		Emission Level		Limit		Margin	
			[dB (uV)]		[dB (uV)]		[dB (uV)]		(dB)	
			Q.P.	AV.	Q.P.	AV.	Q.P.	AV.	Q.P.	AV.
1	0.154	0.13	44.38	28.39	44.51	28.52	65.79	55.79	-21.28	-27.27
2	0.177	0.13	46.51	35.24	46.64	35.37	64.61	54.61	-17.97	-19.24
3	3.848	0.31	34.95	23.82	35.26	24.13	56.00	46.00	-20.74	-21.87
4	4.680	0.35	35.04	25.69	35.39	26.04	56.00	46.00	-20.61	-19.96
5	9.641	0.59	27.15	21.76	27.74	22.35	60.00	50.00	-32.26	-27.65
6	21.020	0.96	27.83	21.92	28.79	22.88	60.00	50.00	-31.21	-27.12

- REMARKS:**
1. Q.P. and AV. are abbreviations of quasi-peak and average individually.
 2. "-": The Quasi-peak reading value also meets average limit and measurement with the average detector is unnecessary.
 3. The emission levels of other frequencies were very low against the limit.
 4. Margin value = Emission level - Limit value
 5. Correction factor = Insertion loss + Cable loss
 6. Emission Level = Correction Factor + Reading Value.

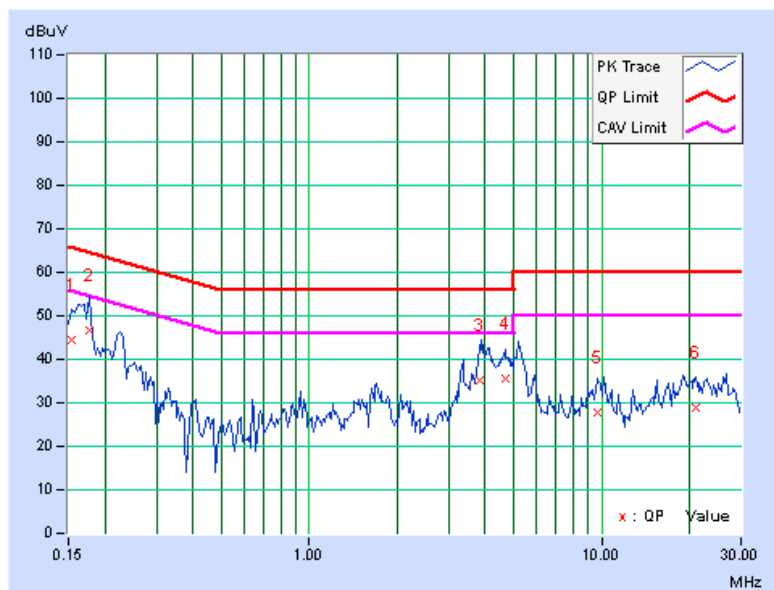

4.3 MAXIMUM CONDUCTED OUTPUT POWER MEASUREMENT

4.3.1 LIMITS OF MAXIMUM CONDUCTED OUTPUT POWER MEASUREMENT

FREQUENCY BAND	LIMIT
5.150 ~ 5.250GHz	The lesser of 50mW (17dBm) or 4dBm + 10logB
5.250 ~ 5.350GHz	The lesser of 250mW (24dBm) or 11dBm + 10logB
5.470 ~ 5.725GHz	The lesser of 250mW (24dBm) or 11dBm + 10logB

NOTE: Where B is the 26dB emission bandwidth in MHz.

4.3.2 TEST SETUP

FOR POWER OUTPUT MEASUREMENT

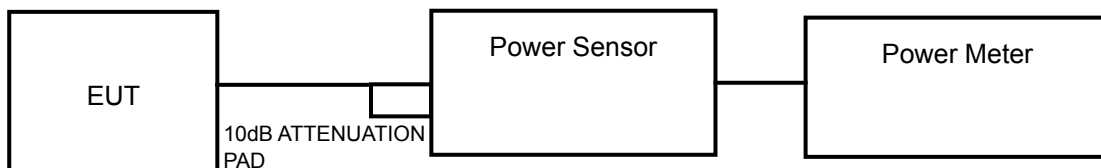

FOR 26dB BANDWIDTH

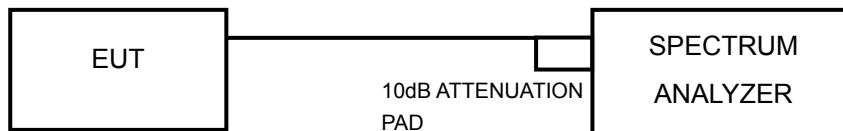

4.3.3 TEST INSTRUMENTS

Refer to section 4.1.3 to get information of above instrument.

4.3.4 TEST PROCEDURE

FOR AVERAGE POWER MEASUREMENT

A power sensor was used on the output port of the EUT. A power meter was used to read the response of the power sensor. Record the power level.

FOR 26dB BANDWIDTH

- 1) Set RBW = approximately 1% of the emission bandwidth.
- 2) Set the VBW > RBW.
- 3) Detector = Peak.
- 4) Trace mode = max hold.
- 5) Measure the maximum width of the emission that is 26 dB down from the peak of the emission. Compare this with the RBW setting of the analyzer. Readjust RBW and repeat measurement as needed until the RBW/EBW ratio is approximately 1%.

4.3.5 DEVIATION FROM TEST STANDARD

No deviation.

4.3.6 EUT OPERATING CONDITIONS

The software provided by client to enable the EUT under transmission condition continuously at specific channel frequencies individually.

4.3.7 TEST RESULTS

POWER OUTPUT: 802.11a

CHANNEL	CHANNEL FREQUENCY (MHz)	OUTPUT POWER (mW)	OUTPUT POWER (dBm)	POWER LIMIT (dBm)	PASS / FAIL
36	5180	26.3	14.2	17	PASS
40	5200	25.7	14.1	17	PASS
48	5240	26.3	14.2	17	PASS
52	5260	26.9	14.3	24	PASS
60	5300	26.3	14.2	24	PASS
64	5320	26.3	14.2	24	PASS
100	5500	19.1	12.8	24	PASS
116	5580	26.9	14.3	24	PASS
132	5660	14.1	11.5	24	PASS
140	5700	7.1	8.5	24	PASS

802.11n (20MHz)

CHAN.	CHAN. FREQ. (MHz)	POWER OUTPUT (dBm)		TOTAL POWER (mW)	TOTAL POWER (dBm)	POWER LIMIT (dBm)	PASS / FAIL
		CHAIN 0	CHAIN 1				
36	5180	12.2	12.5	34.4	15.4	17	PASS
40	5200	12.2	12.1	32.8	15.2	17	PASS
48	5240	12.1	12.3	33.2	15.2	17	PASS
52	5260	12.3	12.0	32.8	15.2	24	PASS
60	5300	12.5	12.2	34.4	15.4	24	PASS
64	5320	12.2	12.0	32.4	15.1	24	PASS
100	5500	12.3	12.2	33.6	15.3	24	PASS
116	5580	12.1	12.2	32.8	15.2	24	PASS
132	5660	12.2	12.1	32.8	15.2	24	PASS
140	5700	9.8	9.6	18.7	12.7	24	PASS



802.11n (40MHz)

CHAN.	CHAN. FREQ. (MHz)	POWER OUTPUT (dBm)		TOTAL POWER (mW)	TOTAL POWER (dBm)	POWER LIMIT (dBm)	PASS / FAIL
		CHAIN 0	CHAIN 1				
38	5190	12.3	12.2	33.6	15.3	17	PASS
46	5230	12.4	12.2	34.0	15.3	17	PASS
54	5270	12.4	12.1	33.6	15.3	24	PASS
62	5310	12.3	12.2	33.6	15.3	24	PASS
102	5510	12.2	12.2	33.2	15.2	24	PASS
110	5550	12.1	12.3	33.2	15.2	24	PASS
134	5670	12.2	12.1	32.8	15.2	24	PASS

**26dB BANDWIDTH: 802.11a**

CHANNEL	CHANNEL FREQUENCY (MHz)	26dBc BANDWIDTH (MHz)	PASS / FAIL
36	5180	23.93	PASS
40	5200	23.87	PASS
48	5240	24.06	PASS
52	5260	24.49	PASS
60	5300	24.55	PASS
64	5320	24.12	PASS
100	5500	23.50	PASS
116	5580	28.28	PASS
132	5660	23.67	PASS
140	5700	23.36	PASS

802.11n (20MHz)

CHANNEL	CHANNEL FREQUENCY (MHz)	26dBc BANDWIDTH (MHz)		PASS / FAIL
		CHAIN 0	CHAIN 1	
36	5180	25.04	23.84	PASS
40	5200	25.28	23.87	PASS
48	5240	25.13	23.88	PASS
52	5260	25.18	23.91	PASS
60	5300	26.26	23.85	PASS
64	5320	26.30	23.43	PASS
100	5500	25.12	23.36	PASS
116	5580	25.23	24.21	PASS
132	5660	26.21	25.48	PASS
140	5700	24.46	23.63	PASS



802.11n (40MHz)

CHANNEL	CHANNEL FREQUENCY (MHz)	26dBc BANDWIDTH (MHz)		PASS / FAIL
		CHAIN 0	CHAIN 1	
38	5190	46.27	45.79	PASS
46	5230	48.26	45.71	PASS
54	5270	48.55	45.57	PASS
62	5310	48.01	48.24	PASS
102	5510	46.51	48.43	PASS
110	5550	47.96	48.61	PASS
134	5670	48.96	53.13	PASS

4.4 PEAK POWER EXCURSION MEASUREMENT

4.4.1 LIMITS OF PEAK POWER EXCURSION MEASUREMENT

Shall not exceed 13 dB

4.4.2 TEST SETUP

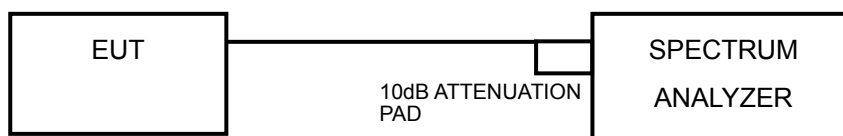

4.4.3 TEST INSTRUMENTS

Refer to section 4.1.3 to get information of above instrument.

4.4.4 TEST PROCEDURE

- 1) Set RBW = 1 MHz, VBW \leq 3 MHz, Detector = peak.
- 2) Trace mode = max-hold. Allow the sweeps to continue until the trace stabilizes.
- 3) Use the peak search function to find the peak of the spectrum.
- 4) Measure the PPSD.
- 5) Compute the ratio of the maximum of the peak-max-hold spectrum to the PPSD.

4.4.5 DEVIATION FROM TEST STANDARD

No deviation.

4.4.6 EUT OPERATING CONDITIONS

Same as 4.2.6



4.4.7 TEST RESULTS

802.11a

CHANNEL	CHANNEL FREQUENCY (MHz)	PEAK VALUE (dBm)	PPSD (dBm)	PEAK POWER EXCURSION (dB)	PEAK to AVERAGE EXCURSION LIMIT (dB)	PASS/FAIL
36	5180	11.74	2.85	8.89	13	PASS
40	5200	11.71	2.71	9.00	13	PASS
48	5240	11.55	2.77	8.78	13	PASS
52	5260	11.72	2.95	8.77	13	PASS
60	5300	11.66	2.60	9.06	13	PASS
64	5320	11.59	2.67	8.92	13	PASS
100	5500	10.49	1.62	8.87	13	PASS
116	5580	11.86	3.10	8.76	13	PASS
132	5660	8.81	-0.08	8.89	13	PASS
140	5700	5.80	-2.90	8.70	13	PASS



A D T

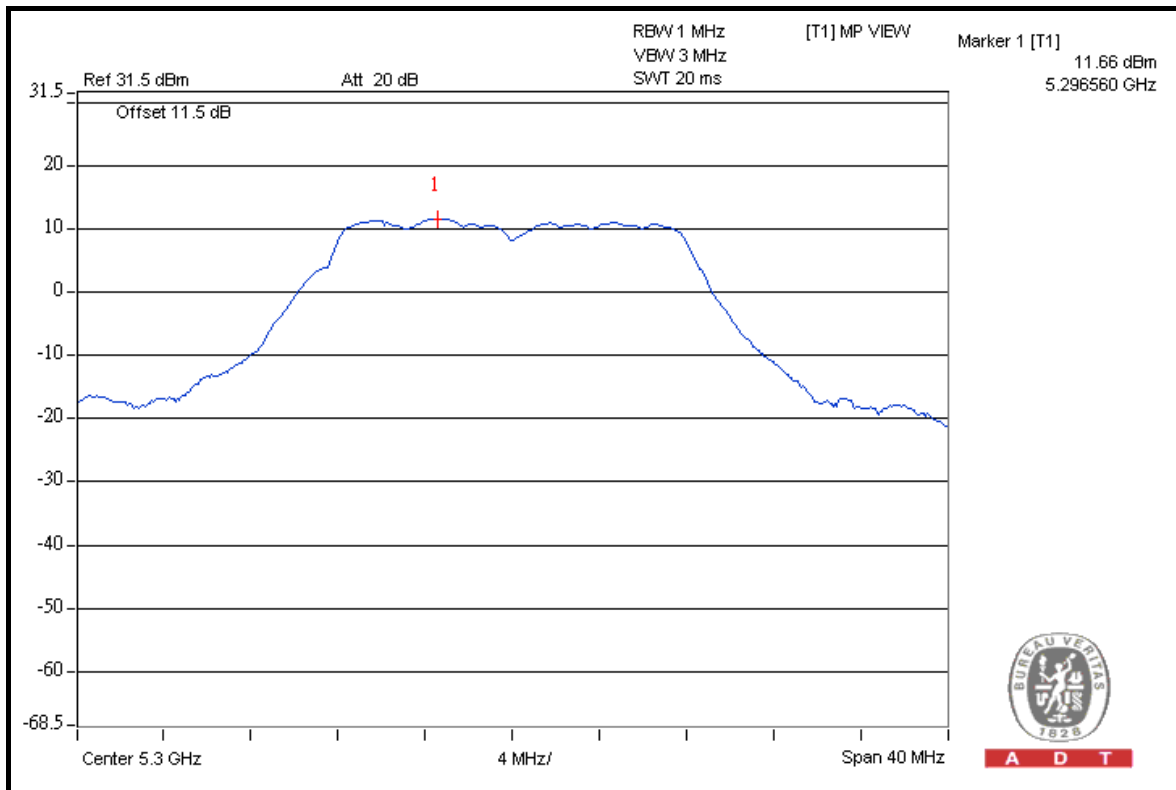

A D T

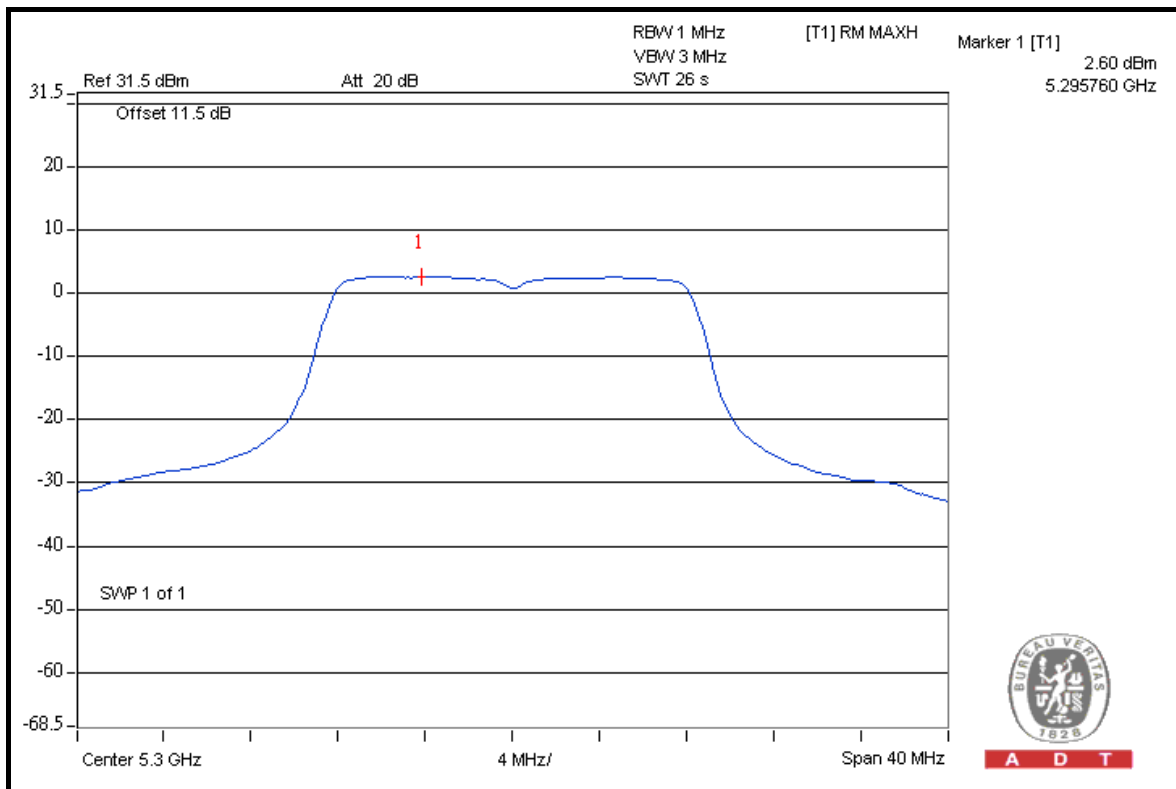

A D T



802.11n (20MHz)

TX chain	CHAN.	CHANNEL FREQUENCY (MHz)	PEAK VALUE (dBm)	PPSD (dBm)	PEAK POWER EXCURSION (dB)	PEAK to AVERAGE EXCURSION LIMIT (dB)	PASS /FAIL
0	36	5180	10.21	0.84	9.37	13	PASS
	40	5200	10.34	0.83	9.51	13	PASS
	48	5240	10.13	0.55	9.58	13	PASS
	52	5260	10.25	0.93	9.32	13	PASS
	60	5300	10.33	0.99	9.34	13	PASS
	64	5320	10.32	0.76	9.56	13	PASS
	100	5500	10.33	0.84	9.49	13	PASS
	116	5580	9.88	0.56	9.32	13	PASS
	132	5660	10.15	0.50	9.65	13	PASS
	140	5700	7.65	-1.98	9.63	13	PASS
1	36	5180	10.22	0.94	9.28	13	PASS
	40	5200	9.84	0.80	9.04	13	PASS
	48	5240	9.77	0.63	9.14	13	PASS
	52	5260	9.62	0.49	9.13	13	PASS
	60	5300	9.67	0.54	9.13	13	PASS
	64	5320	9.80	0.73	9.07	13	PASS
	100	5500	10.00	0.75	9.25	13	PASS
	116	5580	10.09	0.64	9.45	13	PASS
	132	5660	9.84	0.78	9.06	13	PASS
	140	5700	7.25	-1.80	9.05	13	PASS



A D T

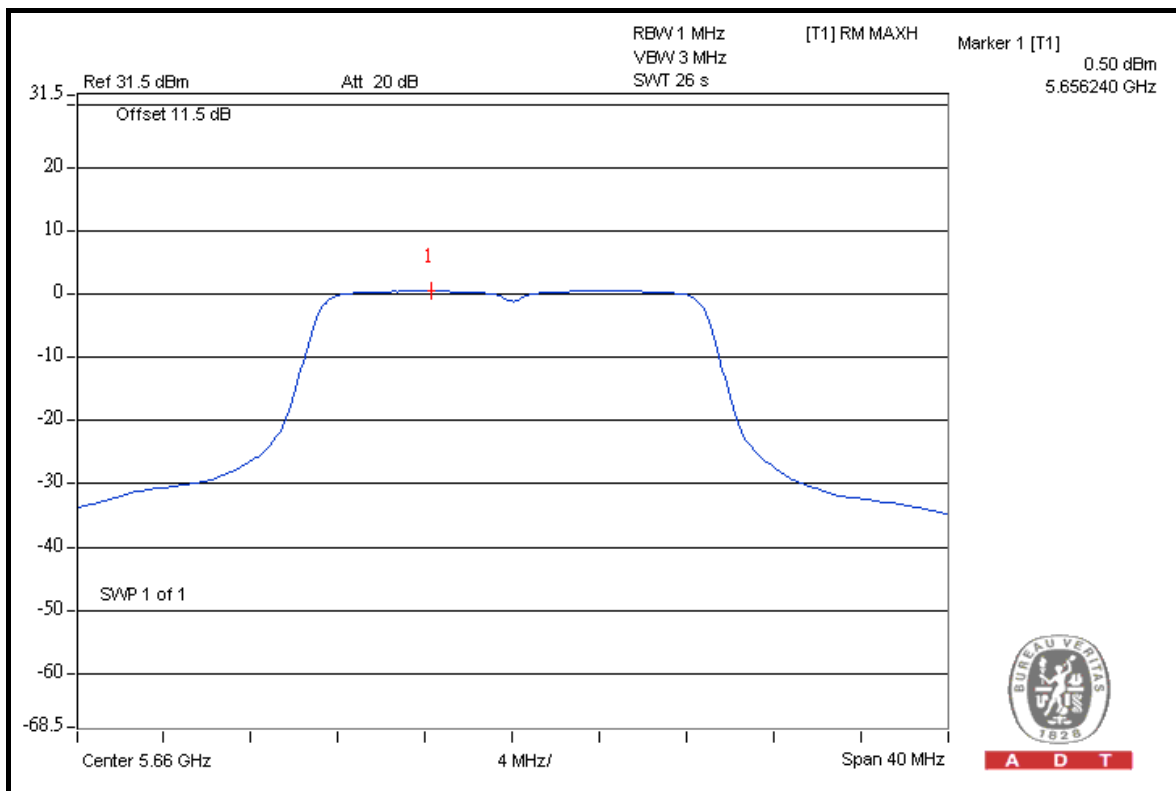
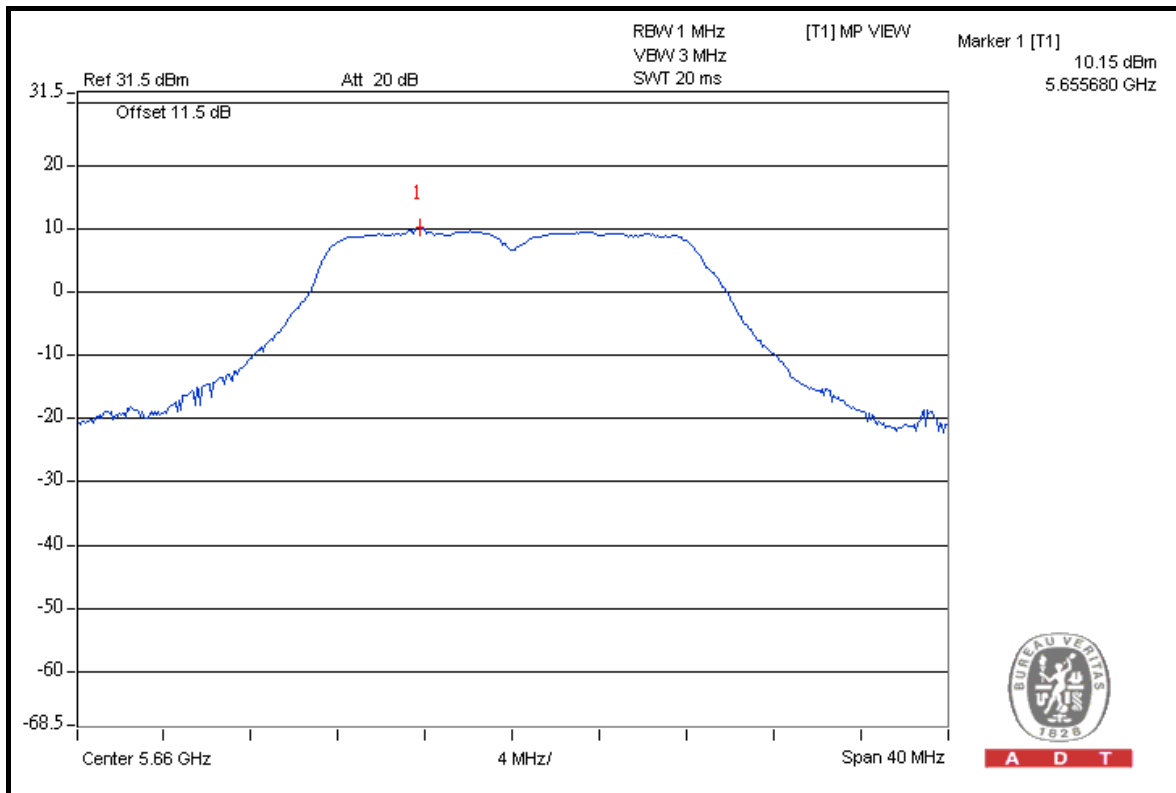



802.11n (40MHz)

TX chain	CHAN.	CHANNEL FREQUENCY (MHz)	PEAK VALUE (dBm)	PPSD (dBm)	PEAK POWER EXCURSION (dB)	PEAK to AVERAGE EXCURSION LIMIT (dB)	PASS /FAIL
0	38	5190	7.39	-1.92	9.31	13	PASS
	46	5230	7.46	-1.83	9.29	13	PASS
	54	5270	7.36	-1.66	9.02	13	PASS
	62	5310	7.24	-1.96	9.20	13	PASS
	102	5510	7.09	-2.07	9.16	13	PASS
	110	5550	7.14	-2.13	9.27	13	PASS
	134	5670	7.15	-2.04	9.19	13	PASS
1	38	5190	8.00	-1.83	9.83	13	PASS
	46	5230	7.86	-1.93	9.79	13	PASS
	54	5270	7.68	-2.17	9.85	13	PASS
	62	5310	7.91	-1.90	9.81	13	PASS
	102	5510	7.96	-1.73	9.69	13	PASS
	110	5550	8.02	-1.80	9.82	13	PASS
	134	5670	7.84	-1.92	9.76	13	PASS



A D T

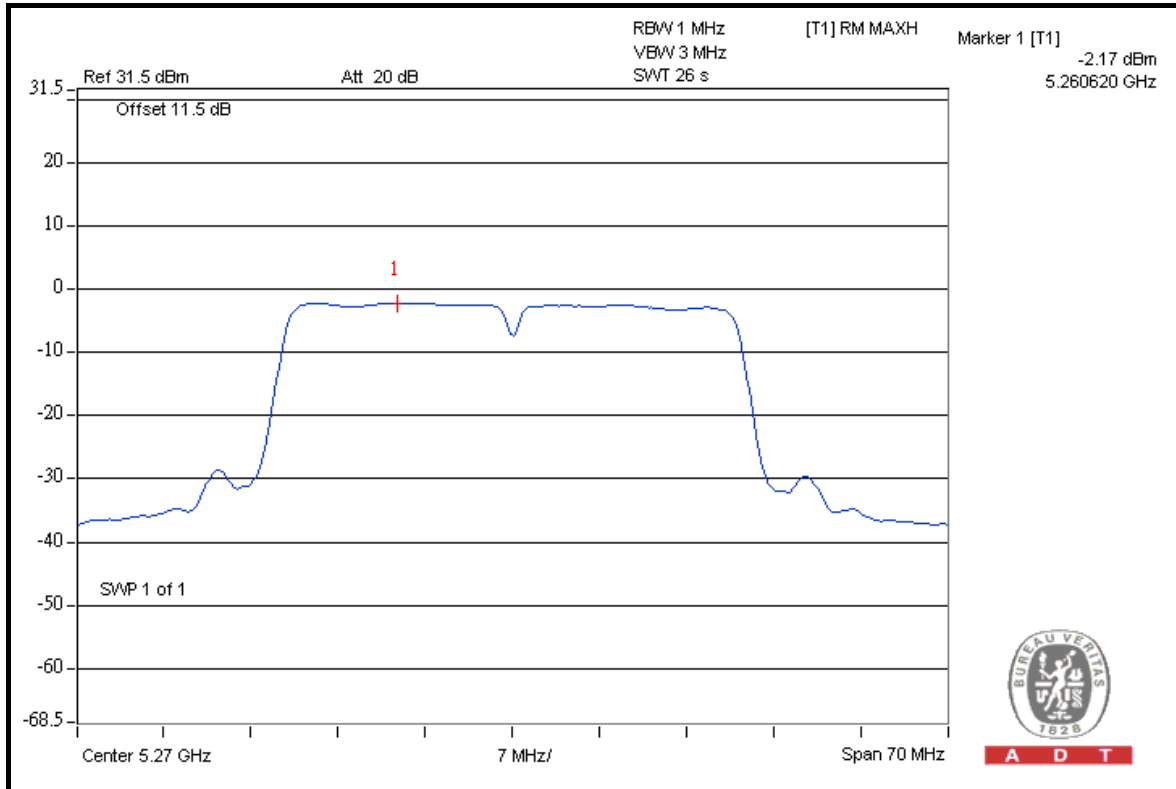
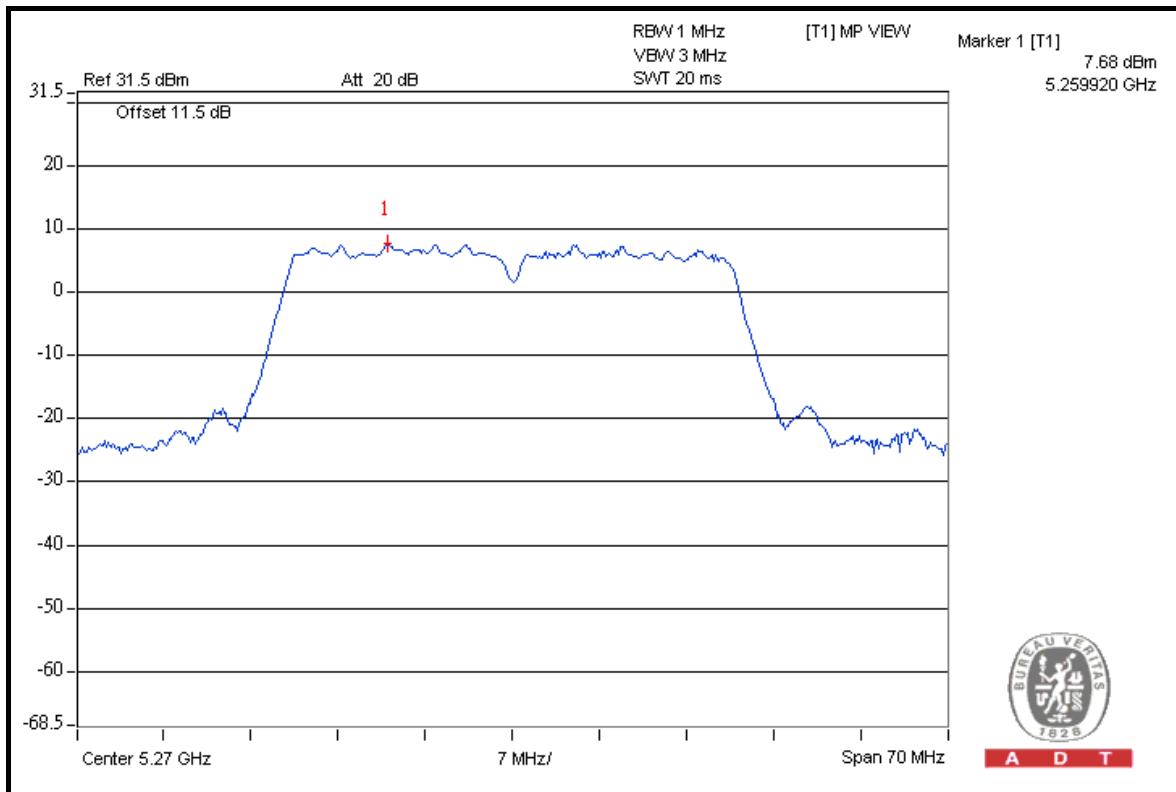

4.5 PEAK POWER SPECTRAL DENSITY MEASUREMENT

4.5.1 LIMITS OF PEAK POWER SPECTRAL DENSITY MEASUREMENT

FREQUENCY BAND	LIMIT(dBm)
5.15 ~ 5.25GHz	4
5.25 ~ 5.35GHz and 5.470 ~ 5.725GHz	11
5.725~5825GHz	17

4.5.2 TEST SETUP

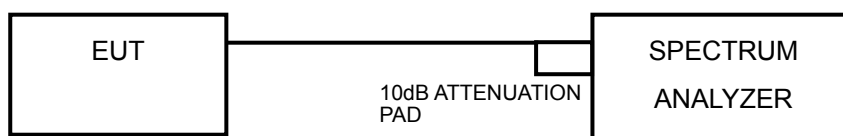

4.5.3 TEST INSTRUMENTS

Refer to section 4.1.3 to get information of above instrument.

4.5.4 TEST PROCEDURES

- 1) Set span to encompass the entire emission bandwidth (EBW) of the signal.
- 2) Set RBW = 1 MHz, Set VBW \geq 3 MHz, Detector = RMS
- 3) Sweep time = auto, trigger set to “free run”.
- 4) Trace average at least 100 traces in power averaging mode.

4.5.5 DEVIATION FROM TEST STANDARD

No deviation.

4.5.6 EUT OPERATING CONDITIONS

Same as 4.3.6.



A D T

4.5.7 TEST RESULTS

802.11a

CHANNEL	FREQUENCY (MHz)	PSD (dBm)	MAXIMUM LIMIT (dBm)	PASS/FAIL
36	5180	2.85	4	PASS
40	5200	2.71	4	PASS
48	5240	2.77	4	PASS
52	5260	2.95	11	PASS
60	5300	2.60	11	PASS
64	5320	2.67	11	PASS
100	5500	1.62	11	PASS
116	5580	3.10	11	PASS
132	5660	-0.08	11	PASS
140	5700	-2.90	11	PASS



802.11n (20MHz)

CHAN.	CHAN. FREQ. (MHz)	RF POWER LEVEL IN 1MHz BW (dBm)		TOTAL POWER DENSITY (dBm)	MAX. LIMIT (dBm)	PASS / FAIL
		CHAIN 0	CHAIN 1			
36	5180	0.84	0.94	3.891	4	PASS
40	5200	0.83	0.80	3.826	4	PASS
48	5240	0.55	0.63	3.587	4	PASS
52	5260	0.93	0.49	3.724	11	PASS
60	5300	0.99	0.54	3.779	11	PASS
64	5320	0.76	0.73	3.754	11	PASS
100	5500	0.84	0.75	3.803	11	PASS
116	5580	0.56	0.64	3.61	11	PASS
132	5660	0.50	0.78	3.653	11	PASS
140	5700	-1.98	-1.80	1.123	11	PASS

NOTE: Method 1 of power density measurement of KDB 662911 is using for calculating total power density. Total power density is summing entire spectra across corresponding frequency bins on the various outputs by computer

802.11n (40MHz)

CHAN.	CHAN. FREQ. (MHz)	RF POWER LEVEL IN 1MHz BW (dBm)		TOTAL POWER DENSITY (dBm)	MAX. LIMIT (dBm)	PASS / FAIL
		CHAIN 0	CHAIN 1			
38	5190	-1.92	-1.83	1.113	4	PASS
46	5230	-1.83	-1.93	1.116	4	PASS
54	5270	-1.66	-2.17	1.096	11	PASS
62	5310	-1.96	-1.90	1.054	11	PASS
102	5510	-2.07	-1.73	1.112	11	PASS
110	5550	-2.13	-1.80	1.047	11	PASS
134	5670	-2.04	-1.92	1.017	11	PASS

NOTE: Method 1 of power density measurement of KDB 662911 is using for calculating total power density. Total power density is summing entire spectra across corresponding frequency bins on the various outputs by computer

4.6 FREQUENCY STABILITY

4.6.1 LIMITS OF FREQUENCY STABILITY MEASUREMENT

The frequency of the carrier signal shall be maintained within band of operation

4.6.2 TEST SETUP

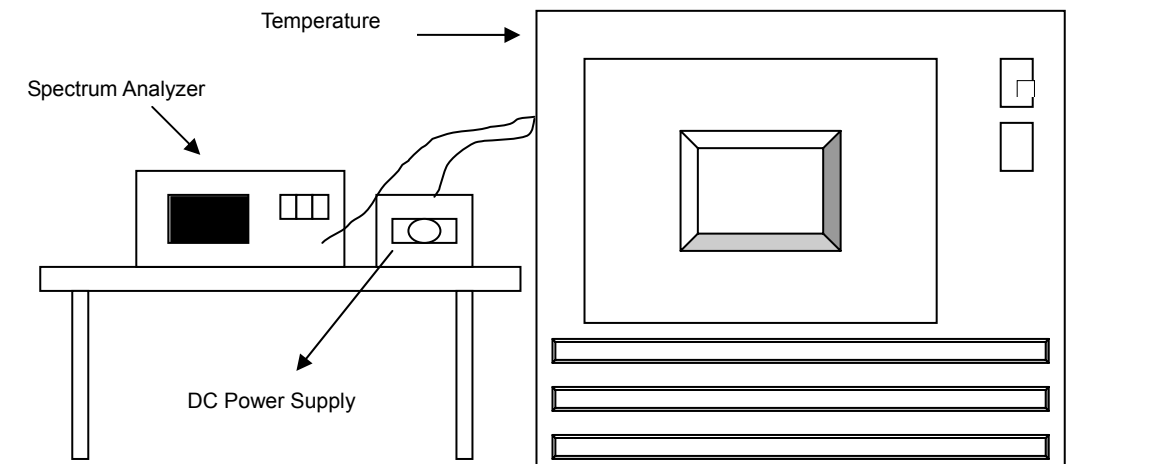

4.6.3 TEST INSTRUMENTS

Refer to section 4.1.3 to get information of above instrument.

4.6.4 TEST PROCEDURE

- a. The EUT was placed inside the environmental test chamber and powered by nominal DC voltage.
- b. Turn the EUT on and couple its output to a spectrum analyzer.
- c. Turn the EUT off and set the chamber to the highest temperature specified.
- d. Allow sufficient time (approximately 30 min) for the temperature of the chamber to stabilize, turn the EUT on and measure the operating frequency after 2, 5, and 10 minutes.
- e. Repeat step 2 and 3 with the temperature chamber set to the lowest temperature.
- f. The test chamber was allowed to stabilize at +20 degree C for a minimum of 30 minutes. The supply voltage was then adjusted on the EUT from 85% to 115% and the frequency record.

4.6.5 DEVIATION FROM TEST STANDARD

No deviation.

4.6.6 EUT OPERATING CONDITION

Set the EUT transmit at un-modulation mode to test frequency stability.



4.6.7 TEST RESULTS

FREQUENCY STABILITY VERSUS TEMP.									
OPERATING FREQUENCY: 5200MHz									
TEMP. (°C)	POWER SUPPLY (Vac)	0 MINUTE		2 MINUTE		5 MINUTE		10 MINUTE	
		Measured Frequency (MHz)	Frequency Drift (ppm)	Measured Frequency (MHz)	Frequency Drift (ppm)	Measured Frequency (MHz)	Frequency Drift (ppm)	Measured Frequency (MHz)	Frequency Drift (ppm)
55	110.0	5199.987815	-2.343	5199.987508	-2.402	5199.988248	-2.260	5199.988086	-2.291
50	110.0	5199.988872	-2.140	5199.988765	-2.161	5199.988901	-2.134	5199.988753	-2.163
40	110.0	5199.989611	-1.998	5199.989544	-2.011	5199.989734	-1.974	5199.989775	-1.966
30	110.0	5199.991768	-1.583	5199.991935	-1.551	5199.991185	-1.695	5199.991712	-1.594
20	110.0	5199.992726	-1.399	5199.992753	-1.394	5199.992704	-1.403	5199.992200	-1.500
10	110.0	5199.991469	-1.641	5199.991107	-1.710	5199.991047	-1.722	5199.991342	-1.665
0	110.0	5199.990088	-1.906	5199.990020	-1.919	5199.989965	-1.930	5199.990131	-1.898
-10	110.0	5199.989139	-2.089	5199.989275	-2.063	5199.988951	-2.125	5199.989376	-2.043
-20	110.0	5199.987990	-2.310	5199.988215	-2.266	5199.988248	-2.260	5199.988097	-2.289

FREQUENCY STABILITY VERSUS VOLTAGE									
OPERATING FREQUENCY: 5200MHz									
TEMP. (°C)	POWER SUPPLY (Vac)	0 MINUTE		2 MINUTE		5 MINUTE		10 MINUTE	
		Measured Frequency (MHz)	Frequency Drift (ppm)	Measured Frequency (MHz)	Frequency Drift (ppm)	Measured Frequency (MHz)	Frequency Drift (ppm)	Measured Frequency (MHz)	Frequency Drift (ppm)
20	93.5	5199.992348	-1.472	5199.992098	-1.520	5199.991571	-1.621	5199.992117	-1.516
	110.0	5199.992726	-1.399	5199.992753	-1.394	5199.992704	-1.403	5199.992200	-1.500
	126.5	5199.991845	-1.568	5199.991806	-1.576	5199.991468	-1.641	5199.991365	-1.661

5. PHOTOGRAPHS OF THE TEST CONFIGURATION

Please refer to the attached file (Test Setup Photo).



6. INFORMATION ON THE TESTING LABORATORIES

We, Bureau Veritas Consumer Products Services (H.K.) Ltd., Taoyuan Branch, were founded in 1988 to provide our best service in EMC, Radio, Telecom and Safety consultation. Our laboratories are accredited and approved according to ISO/IEC 17025.

Copies of accreditation and authorization certificates of our laboratories obtained from approval agencies can be downloaded from our web site: www.adt.com.tw/index.5.phtml. If you have any comments, please feel free to contact us at the following:

Linko EMC/RF Lab:

Tel: 886-2-26052180

Fax: 886-2-26051924

Hsin Chu EMC/RF Lab:

Tel: 886-3-5935343

Fax: 886-3-5935342

Hwa Ya EMC/RF/Safety Telecom Lab:

Tel: 886-3-3183232

Fax: 886-3-3185050

Email: service.adt@tw.bureauveritas.com

Web Site: www.adt.com.tw

The address and road map of all our labs can be found in our web site also.



A D T

7. APPENDIX A - MODIFICATIONS RECORDERS FOR ENGINEERING CHANGES TO THE EUT BY THE LAB

No modifications were made to the EUT by the lab during the test.

---END---