



FCC TEST REPORT

REPORT NO.: RF970825L08

MODEL NO.: WLI-UC-G300HP

RECEIVED: Aug. 25, 2008

TESTED: Nov. 24 ~ Dec. 16, 2008

ISSUED: Dec. 23, 2008

APPLICANT: Buffalo Inc.

ADDRESS: 4-15, Shibata Hondori 4-chome, Minami-ku,
Nagoya 457-8520, Japan

ISSUED BY: Bureau Veritas Consumer Products Services
(H.K.) Ltd., Taoyuan Branch

LAB ADDRESS: No. 47, 14th Ling, Chia Pau Tsuen, Lin Kou
Hsiang, Taipei Hsien 244, Taiwan, R.O.C.

TEST LOCATION: No. 19, Hwa Ya 2nd Rd, Wen Hwa Tsuen, Kwei
Shan Hsiang, Taoyuan Hsien 333, Taiwan,
R.O.C.

This test report consists of 112 pages in total. It may be duplicated completely for legal use with the approval of the applicant. It should not be reproduced except in full, without the written approval of our laboratory. The client should not use it to claim product endorsement by TAF or any government agencies. The test results in the report only apply to the tested sample.





TABLE OF CONTENTS

1.	CERTIFICATION	4
2.	SUMMARY OF TEST RESULTS	5
2.1	MEASUREMENT UNCERTAINTY	5
3.	GENERAL INFORMATION	6
3.1	GENERAL DESCRIPTION OF EUT	6
3.2	DESCRIPTION OF TEST MODES	7
3.2.1	CONFIGURATION OF SYSTEM UNDER TEST	7
3.2.2	TEST MODE APPLICABILITY AND TESTED CHANNEL DETAIL	8
3.3	GENERAL DESCRIPTION OF APPLIED STANDARDS	10
3.4	DESCRIPTION OF SUPPORT UNITS	10
4.	TEST TYPES AND RESULTS	11
4.1	RADIATED EMISSION MEASUREMENT	11
4.1.1	LIMITS OF RADIATED EMISSION MEASUREMENT	11
4.1.2	TEST INSTRUMENTS	12
4.1.3	TEST PROCEDURES	13
4.1.4	DEVIATION FROM TEST STANDARD	13
4.1.5	TEST SETUP	14
4.1.6	EUT OPERATING CONDITIONS	14
4.1.7	TEST RESULTS	15
4.2	CONDUCTED EMISSION MEASUREMENT	35
4.2.1	LIMITS OF CONDUCTED EMISSION MEASUREMENT	35
4.2.2	TEST INSTRUMENTS	35
4.2.3	TEST PROCEDURES	36
4.2.4	DEVIATION FROM TEST STANDARD	36
4.2.5	TEST SETUP	37
4.2.6	EUT OPERATING CONDITIONS	37
4.2.7	TEST RESULTS	38
4.3	6dB BANDWIDTH MEASUREMENT	42
4.3.1	LIMITS OF 6dB BANDWIDTH MEASUREMENT	42
4.3.2	TEST INSTRUMENTS	42
4.3.3	TEST PROCEDURE	42
4.3.4	DEVIATION FROM TEST STANDARD	42
4.3.5	TEST SETUP	43
4.3.6	EUT OPERATING CONDITIONS	43
4.3.7	TEST RESULTS	44
4.4	MAXIMUM PEAK OUTPUT POWER	60
4.4.1	LIMITS OF MAXIMUM PEAK OUTPUT POWER MEASUREMENT	60
4.4.2	INSTRUMENTS	60
4.4.3	TEST PROCEDURES	60
4.4.4	DEVIATION FROM TEST STANDARD	60
4.4.5	TEST SETUP	61
4.4.6	EUT OPERATING CONDITIONS	61
4.4.7	TEST RESULTS	62
4.5	POWER SPECTRAL DENSITY MEASUREMENT	65
4.5.1	LIMITS OF POWER SPECTRAL DENSITY MEASUREMENT	65
4.5.2	TEST INSTRUMENTS	65
4.5.3	TEST PROCEDURE	65
4.5.4	DEVIATION FROM TEST STANDARD	65
4.5.5	TEST SETUP	66



A D T

4.5.6	EUT OPERATING CONDITION	66
4.5.7	TEST RESULTS	67
4.6	BAND EDGES MEASUREMENT	83
4.6.1	LIMITS OF BAND EDGES MEASUREMENT	83
4.6.2	TEST INSTRUMENTS	83
4.6.3	TEST PROCEDURE	84
4.6.4	DEVIATION FROM TEST STANDARD	84
4.6.5	EUT OPERATING CONDITION	85
4.6.6	TEST RESULTS	85
4.7	ANTENNA REQUIREMENT	109
4.7.1	STANDARD APPLICABLE	109
4.7.2	ANTENNA CONNECTED CONSTRUCTION.....	109
5.	PHOTOGRAPHS OF THE TEST CONFIGURATION	110
6.	INFORMATION ON THE TESTING LABORATORIES.....	111
7.	APPENDIX A - MODIFICATIONS RECORDERS FOR ENGINEERING CHANGES TO THE EUT BY THE LAB	112



A D T

1. CERTIFICATION

PRODUCT: AirStation Wireless-N NFINITI HighPower Keychain
USB2.0 Adapter

MODEL: WLI-UC-G300HP

BRAND: BUFFALO

APPLICANT: Buffalo Inc.

TESTED: Nov. 24 ~ Dec. 16, 2008

TEST SAMPLE: ENGINEERING SAMPLE

STANDARDS: FCC Part 15, Subpart C,
ANSI C63.4-2003

The above equipment (model: WLI-UC-G300HP) has been tested by **Bureau Veritas Consumer Products Services (H.K.) Ltd., Taoyuan Branch,** and found compliance with the requirement of the above standards. The test record, data evaluation & Equipment Under Test (EUT) configurations represented herein are true and accurate accounts of the measurements of the sample's EMC characteristics under the conditions specified in this report.

PREPARED BY : Andrea Hsia , **DATE:** Dec. 23, 2008
Andrea Hsia / Specialist

TECHNICAL
ACCEPTANCE : Long Chen , **DATE:** Dec. 23, 2008
Responsible for RF Long Chen / Senior Engineer

APPROVED BY : Gary Chang , **DATE:** Dec. 23, 2008
Gary Chang / Assistant Manager

2. SUMMARY OF TEST RESULTS

The EUT has been tested according to the following specifications:

APPLIED STANDARD: FCC Part 15, Subpart C			
Standard Section	Test Type and Limit	Result	Remark
15.207	AC Power Conducted Emission	PASS	Meet the requirement of limit. Minimum passing margin is -13.82dB at 0.313MHz.
15.247(a)(2)	Spectrum Bandwidth of a Direct Sequence Spread Spectrum System Limit: min. 500kHz	PASS	Meet the requirement of limit.
15.247(b)	Maximum Peak Output Power Limit: max. 30dBm	PASS	Meet the requirement of limit.
15.247(d)	Radiated Emissions Limit: Table 15.209	PASS	Meet the requirement of limit. Minimum passing margin is -1.02dB at 2390.00MHz.
15.247(e)	Power Spectral Density Limit: max. 8dBm	PASS	Meet the requirement of limit.
15.247(d)	Band Edge Measurement Limit: 20dB less than the peak value of fundamental frequency	PASS	Meet the requirement of limit.

2.1 MEASUREMENT UNCERTAINTY

Where relevant, the following measurement uncertainty levels have been estimated for tests performed on the EUT as specified in CISPR 16-4-2:

MEASUREMENT	FREQUENCY	UNCERTAINTY
Conducted emissions	9kHz~30MHz	2.44 dB
Radiated emissions	30MHz ~ 200MHz	2.93 dB
	200MHz ~1000MHz	2.95 dB
	1GHz ~ 18GHz	2.26 dB
	18GHz ~ 40GHz	1.94 dB

This uncertainty represents an expanded uncertainty expressed at approximately the 95% confidence level using a coverage factor of k=2.

3. GENERAL INFORMATION

3.1 GENERAL DESCRIPTION OF EUT

PRODUCT	AirStation Wireless-N NFINITI HighPower Keychain USB2.0 Adapter
MODEL NO.	WLI-UC-G300HP
FCC ID	FDI-09102026-0
POWER SUPPLY	5Vdc from host equipment
MODULATION TYPE	CCK, DQPSK, DBPSK for DSSS 64QAM, 16QAM, QPSK, BPSK for OFDM
MODULATION TECHNOLOGY	DSSS, OFDM
TRANSFER RATE	802.11b: 11.0/ 5.5/ 2.0/ 1.0Mbps 802.11g: 54.0/ 48.0/ 36.0/ 24.0/ 18.0/ 12.0/ 9.0/ 6.0Mbps Draft 802.11n: up to 300.0Mbps
FREQUENCY RANGE	2412MHz ~ 2462MHz
NUMBER OF CHANNEL	11 for 802.11b, 802.11g, Draft 802.11n (20MHz) 7 for Draft 802.11n (40MHz)
MAXIMUM OUTPUT POWER	453.453mW
ANTENNA TYPE	Refer to note as below
DATA CABLE	0.15m shielded USB cable without core
I/O PORTS	USB
ACCESSORY DEVICES	NA

NOTE:

- The EUT incorporates a MIMO function. Physically, the EUT provides two completed transmitters and two receivers.

MODULATION MODE	TX FUNCTION
802.11b	1TX
802.11g	1TX
Draft 802.11n (20MHz)	1TX / 2TX
Draft 802.11n (40MHz)	1TX / 2TX

- The following antenna was provided to this EUT.

Antenna model name	Antenna type	Gain	Cable loss
C210-510521-A(SSR-83976)	Printed	2.2dBi	0.4dB

- The above EUT information was declared by manufacturer and for more detailed features description, please refer to the manufacturer's specifications or user's manual.

3.2 DESCRIPTION OF TEST MODES

Eleven channels are provided for 802.11b, 802.11g and draft 802.11n (20MHz):

CHANNEL	FREQUENCY	CHANNEL	FREQUENCY
1	2412MHz	7	2442MHz
2	2417MHz	8	2447MHz
3	2422MHz	9	2452MHz
4	2427MHz	10	2457MHz
5	2432MHz	11	2462MHz
6	2437MHz		

Seven channels are provided for draft 802.11n (40MHz):

CHANNEL	FREQUENCY	CHANNEL	FREQUENCY
1	2422MHz	5	2442MHz
2	2427MHz	6	2447MHz
3	2432MHz	7	2452MHz
4	2437MHz		

3.2.1 CONFIGURATION OF SYSTEM UNDER TEST

TEST MODE A

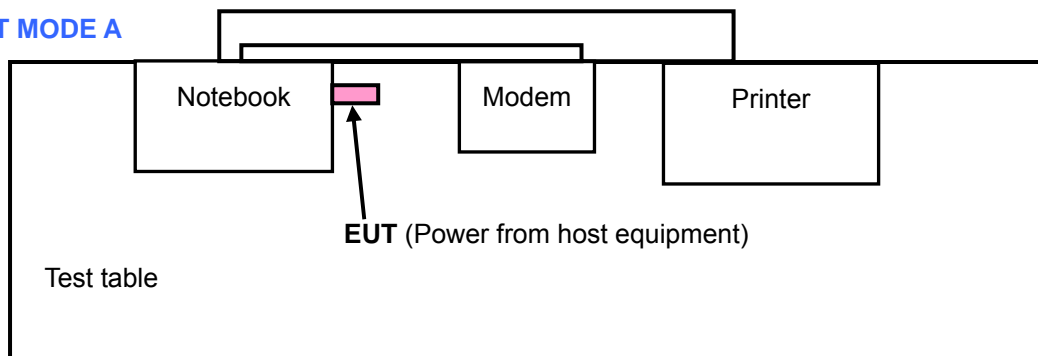

TEST MODE B

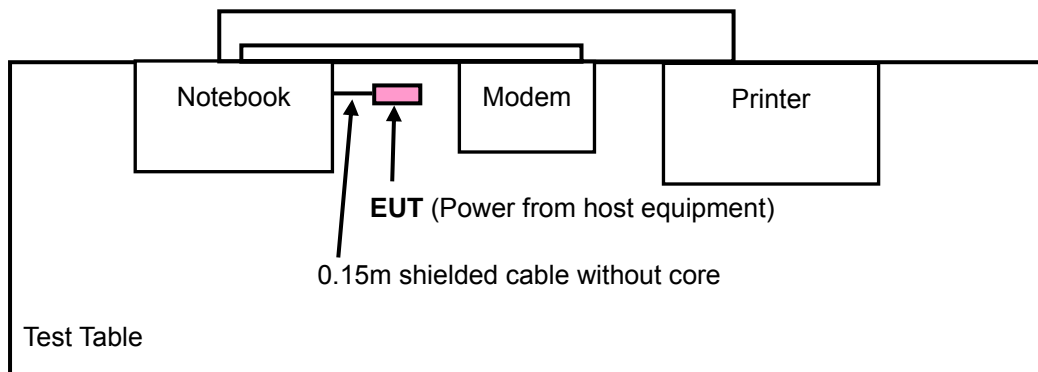



3.2.2 TEST MODE APPLICABILITY AND TESTED CHANNEL DETAIL

EUT CONFIGURE MODE	APPLICABLE TO				DESCRIPTION
	RE≥1G	RE<1G	PLC	APCM	
A	√	√	√	√	EUT only
B	-	√	√	-	EUT with USB cable

Where **PLC**: Power Line Conducted Emission **RE<1G**: Radiated Emission below 1GHz
RE≥1G: Radiated Emission above 1GHz **APCM**: Antenna Port Conducted Measurement
NOTE: "-" means no effect.

RADIATED EMISSION TEST (ABOVE 1 GHz):

- Pre-Scan has been conducted to determine the worst-case mode from all possible combinations between available modulations, data rates, XYZ axis and antenna ports (if EUT with antenna diversity architecture).
- Following channel(s) was (were) selected for the final test as listed below.

EUT CONFIGURE MODE	MODE	AVAILABLE CHANNEL	TESTED CHANNEL	MODULATION TECHNOLOGY	MODULATION TYPE	DATA RATE (Mbps)	TX FUNCTION	AXIS
A	802.11b	1 to 11	1, 6, 11	DSSS	DBPSK	1	1TX	Z
A	802.11g	1 to 11	1, 6, 11	OFDM	BPSK	6	1TX	Z
A	Draft 802.11n (20MHz)	1 to 11	1, 6, 11	OFDM	BPSK	7.2	1TX	Z
A	Draft 802.11n (20MHz)	1 to 11	1, 6, 11	OFDM	BPSK	14.4	2TX	Z
A	Draft 802.11n (40MHz)	1 to 7	1, 4, 7	OFDM	BPSK	15	1TX	Z
A	Draft 802.11n (40MHz)	1 to 7	1, 4, 7	OFDM	BPSK	30	2TX	Z

RADIATED EMISSION TEST (BELOW 1 GHz):

- Pre-Scan has been conducted to determine the worst-case mode from all possible combinations between available modulations, data rates, XYZ axis and antenna ports (if EUT with antenna diversity architecture).
- Following channel(s) was (were) selected for the final test as listed below.

EUT CONFIGURE MODE	MODE	AVAILABLE CHANNEL	TESTED CHANNEL	MODULATION TECHNOLOGY	MODULATION TYPE	DATA RATE (Mbps)	TX FUNCTION	AXIS
A	Draft 802.11n (20MHz)	1 to 11	6	OFDM	BPSK	14.4	2TX	Z
B	Draft 802.11n (20MHz)	1 to 11	6	OFDM	BPSK	14.4	2TX	Z

POWER LINE CONDUCTED EMISSION TEST:

- Pre-Scan has been conducted to determine the worst-case mode from all possible combinations between available modulations, data rates and antenna ports (if EUT with antenna diversity architecture).
- Following channel(s) was (were) selected for the final test as listed below.

EUT CONFIGURE MODE	MODE	AVAILABLE CHANNEL	TESTED CHANNEL	MODULATION TECHNOLOGY	MODULATION TYPE	DATA RATE (Mbps)	TX FUNCTION
A	Draft 802.11n (20MHz)	1 to 11	6	OFDM	BPSK	14.4	2TX
B	Draft 802.11n (20MHz)	1 to 11	6	OFDM	BPSK	14.4	2TX



A D T

BANDEDGE MEASUREMENT:

- Pre-Scan has been conducted to determine the worst-case mode from all possible combinations between available modulations, data rates and antenna ports (if EUT with antenna diversity architecture).
- Following channel(s) was (were) selected for the final test as listed below.

EUT CONFIGURE MODE	MODE	AVAILABLE CHANNEL	TESTED CHANNEL	MODULATION TECHNOLOGY	MODULATION TYPE	DATA RATE (Mbps)	TX FUNCTION
A	802.11b	1 to 11	1, 11	DSSS	DBPSK	1	1TX
A	802.11g	1 to 11	1, 11	OFDM	BPSK	6	1TX
A	Draft 802.11n (20MHz)	1 to 11	1, 11	OFDM	BPSK	7.2	1TX
A	Draft 802.11n (20MHz)	1 to 11	1, 11	OFDM	BPSK	14.4	2TX
A	Draft 802.11n (40MHz)	1 to 7	1, 7	OFDM	BPSK	15	1TX
A	Draft 802.11n (40MHz)	1 to 7	1, 7	OFDM	BPSK	30	2TX

ANTENNA PORT CONDUCTED MEASUREMENT:

- Pre-Scan has been conducted to determine the worst-case mode from all possible combinations between available modulations, data rates, TX function, XYZ axis and antenna ports (if EUT with antenna diversity architecture).
- Following channel(s) was (were) selected for the final test as listed below.

EUT CONFIGURE MODE	MODE	AVAILABLE CHANNEL	TESTED CHANNEL	MODULATION TECHNOLOGY	MODULATION TYPE	DATA RATE (Mbps)	TX FUNCTION
A	802.11b	1 to 11	1, 6, 11	DSSS	DBPSK	1	1TX
A	802.11g	1 to 11	1, 6, 11	OFDM	BPSK	6	1TX
A	Draft 802.11n (20MHz)	1 to 11	1, 6, 11	OFDM	BPSK	7.2	1TX
A	Draft 802.11n (20MHz)	1 to 11	1, 6, 11	OFDM	BPSK	14.4	2TX
A	Draft 802.11n (40MHz)	1 to 7	1, 4, 7	OFDM	BPSK	15	1TX
A	Draft 802.11n (40MHz)	1 to 7	1, 4, 7	OFDM	BPSK	30	2TX

3.3 GENERAL DESCRIPTION OF APPLIED STANDARDS

The EUT is a RF product. According to the specifications of the manufacturer, it must comply with the requirements of the following standards:

FCC Part 15, Subpart C. (15.247)

ANSI C63.4-2003

All test items have been performed and recorded as per the above standards.

NOTE: The EUT is also considered as a kind of computer peripheral, because the connection to computer is necessary for typical use. It has been verified to comply with the requirements of FCC Part 15, Subpart B, Class B (DoC). The test report has been issued separately.

3.4 DESCRIPTION OF SUPPORT UNITS

The EUT has been tested as an independent unit together with other necessary accessories or support units. The following support units or accessories were used to form a representative test configuration during the tests.

NO.	PRODUCT	BRAND	MODEL NO.	SERIAL NO.	FCC ID
1	NOTEBOOK	DELL	D531	CN-0XM006-48 643-81U-2610	QDS-BRCM1020
2	PRINTER	HP	HP LASERJET 1300	CNCM065719	NA
3	MODEM	ACEEX	1414V/3	0401008269	IFAXDM1414

NO.	SIGNAL CABLE DESCRIPTION OF THE ABOVE SUPPORT UNITS
1	NA
2	1.2m braid shielded wire, DB25 & DB9 connector, w/o core.
3	1.8m braid shielded wire, DB25 connector, w/o core.

NOTE: All power cords of the above support units are non shielded (1.8m).

4. TEST TYPES AND RESULTS

4.1 RADIATED EMISSION MEASUREMENT

4.1.1 LIMITS OF RADIATED EMISSION MEASUREMENT

Emissions radiated outside of the specified bands, shall be according to the general radiated limits in 15.209 as following:

FREQUENCIES (MHz)	FIELD STRENGTH (microvolts/meter)	MEASUREMENT DISTANCE (meters)
0.009 ~ 0.490	2400 / F(kHz)	300
0.490 ~ 1.705	24000 / F(kHz)	30
1.705 ~ 30.0	30	30
30 ~ 88	100	3
88 ~ 216	150	3
216 ~ 960	200	3
Above 960	500	3

NOTE:

1. The lower limit shall apply at the transition frequencies.
2. Emission level (dBuV/m) = 20 log Emission level (uV/m).
3. As shown in 15.35(b), for frequencies above 1000MHz, the field strength limits are based on average detector, however, the peak field strength of any emission shall not exceed the maximum permitted average limits, specified above by more than 20dB under any condition of modulation.



4.1.2 TEST INSTRUMENTS

DESCRIPTION & MANUFACTURER	MODEL NO.	SERIAL NO.	DATE OF CALIBRATION	DUE DATE OF CALIBRATION
Test Receiver ROHDE & SCHWARZ	ESIB7	100212	May 28, 2008	May 27, 2009
Spectrum Analyzer ROHDE & SCHWARZ	FSP40	100269	Aug. 08, 2008	Aug. 07, 2009
BILOG Antenna SCHWARZBECK	VULB9168	9168-156	Apr. 25, 2008	Apr. 24, 2009
HORN Antenna SCHWARZBECK	BBHA 9170	BBHA9170242	Jan. 07, 2008	Jan. 06, 2009
Preamplifier Agilent	8449B	3008A01911	Sep. 10, 2008	Sep. 09, 2009
Preamplifier Agilent	8447D	2944A10634	Oct. 23, 2008	Oct. 22, 2009
RF signal cable HUBER+SUHNNER	SUCOFLEX 104	218190/4 231241/4	May 20, 2008	May 19, 2009
RF signal cable Worken	8D-FB	Cable-HYCH9-01	Aug. 09, 2008	Aug. 08, 2009
Software	ADT_Radiated_ V7.6.15.9.2	NA	NA	NA
Antenna Tower EMCO	2070/2080	512.835.4684	NA	NA
Turn Table EMCO	2087-2.03	NA	NA	NA
Antenna Tower & Turn Table Controller EMCO	2090	NA	NA	NA

- NOTE:**
1. The calibration interval of the above test instruments is 12 months and the calibrations are traceable to NML/ROC and NIST/USA.
 2. The test was performed in HwaYa Chamber 9.
 3. The horn antenna and HP preamplifier (model: 8449B) are used only for the measurement of emission frequency above 1GHz if tested.
 4. The FCC Site Registration No. is 460141.
 5. The IC Site Registration No. is IC 7450F-4.

4.1.3 TEST PROCEDURES

- a. The EUT was placed on the top of a rotating table 0.8 meters above the ground at a 3 meters semi-anechoic chamber. The table was rotated 360 degrees to determine the position of the highest radiation.
- b. The EUT was set 3 meters away from the interference-receiving antenna, which was mounted on the top of a variable-height antenna tower.
- c. The antenna is a broadband antenna, and its height is varied from one meter to four meters above the ground to determine the maximum value of the field strength. Both horizontal and vertical polarizations of the antenna are set to make the measurement.
- d. For each suspected emission, the EUT was arranged to its worst case and then the antenna was tuned to heights from 1 meter to 4 meters and the rotatable table was turned from 0 degrees to 360 degrees to find the maximum reading.
- e. The test-receiver system was set to Peak Detect Function and Specified Bandwidth with Maximum Hold Mode.
- f. If the emission level of the EUT in peak mode was lower than the limit specified, then testing could be stopped and the peak values of the EUT would be reported. Otherwise the emissions would be re-tested one by one using peak, quasi-peak or average method as specified and then reported in a data sheet.

NOTE:

1. The resolution bandwidth and video bandwidth of test receiver/spectrum analyzer is 120kHz for Peak detection (PK) and Quasi-peak detection (QP) at frequency below 1GHz.
2. The resolution bandwidth of test receiver/spectrum analyzer is 1 MHz and video bandwidth is 3MHz for Peak detection at frequency above 1GHz.
3. The resolution bandwidth of test receiver/spectrum analyzer is 1MHz and the video bandwidth is 1kHz for Average detection (AV) at frequency above 1GHz.
4. All modes of operation were investigated and the worst-case emissions are reported.

4.1.4 DEVIATION FROM TEST STANDARD

No deviation

4.1.5 TEST SETUP

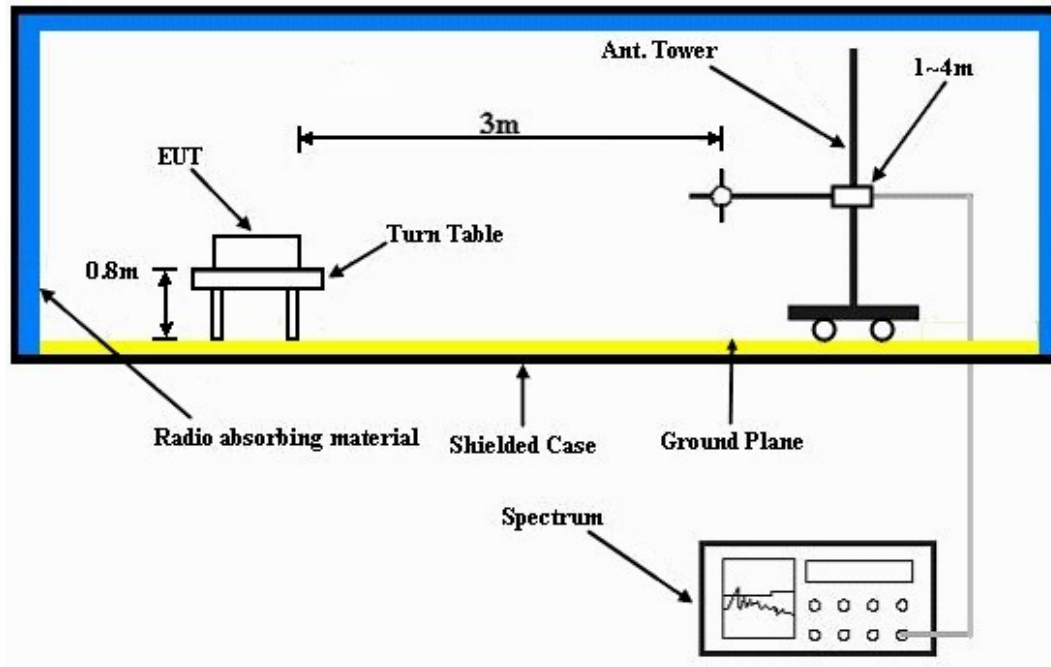

For the actual test configuration, please refer to the attached file (Test Setup Photo)

4.1.6 EUT OPERATING CONDITIONS

TEST MODE A

- a. Plugged the EUT into a notebook system and placed on a testing table.
- b. The notebook system ran a test program (provided by manufacturer) to enable EUT under transmission condition continuously at specific channel frequency.
- c. The necessary accessories enable the system in full functions.

TEST MODE B

- a. Plugged the EUT via USB cable into a notebook system and placed on a testing table.
- b. The notebook system ran a test program (provided by manufacturer) to enable EUT under transmission condition continuously at specific channel frequency.
- c. The necessary accessories enable the system in full functions.

4.1.7 TEST RESULTS

802.11b DSSS MODULATION: 1TX

EUT TEST CONDITION		MEASUREMENT DETAIL	
CHANNEL	Channel 1	FREQUENCY RANGE	1 ~ 25GHz
INPUT POWER (SYSTEM)	120Vac, 60 Hz	DETECTOR FUNCTION	Peak (PK) Average (AV)
ENVIRONMENTAL CONDITIONS	22deg. C, 67%RH 1000hPa	TEST MODE	A
TESTED BY	Antony Lee		

ANTENNA POLARITY & TEST DISTANCE: HORIZONTAL AT 3 M								
NO.	FREQ. (MHz)	EMISSION LEVEL (dBuV/m)	LIMIT (dBuV/m)	MARGIN (dB)	ANTENNA HEIGHT (m)	TABLE ANGLE (Degree)	RAW VALUE (dBuV)	CORRECTION FACTOR (dB/m)
1	2390.00	61.70 PK	74.00	-12.30	1.08 H	30	28.62	33.08
2	2390.00	51.38 AV	54.00	-2.62	1.08 H	30	18.30	33.08
3	*2412.00	101.93 PK			1.07 H	30	68.75	33.18
4	*2412.00	98.45 AV			1.07 H	30	65.27	33.18
5	4824.00	47.82 PK	74.00	-26.18	1.10 H	106	8.67	39.15
6	4824.00	33.59 AV	54.00	-20.41	1.10 H	106	-5.56	39.15
ANTENNA POLARITY & TEST DISTANCE: VERTICAL AT 3 M								
NO.	FREQ. (MHz)	EMISSION LEVEL (dBuV/m)	LIMIT (dBuV/m)	MARGIN (dB)	ANTENNA HEIGHT (m)	TABLE ANGLE (Degree)	RAW VALUE (dBuV)	CORRECTION FACTOR (dB/m)
1	2390.00	62.10 PK	74.00	-11.90	1.00 V	45	29.02	33.08
2	2390.00	52.97 AV	54.00	-1.03	1.00 V	45	19.89	33.08
3	*2412.00	106.55 PK			1.17 V	45	73.37	33.18
4	*2412.00	102.32 AV			1.17 V	45	69.14	33.18
5	4824.00	47.37 PK	74.00	-26.63	1.00 V	162	8.22	39.15
6	4824.00	33.79 AV	54.00	-20.21	1.00 V	162	-5.36	39.15

- REMARKS:**
1. Emission level (dBuV/m) = Raw Value (dBuV) + Correction Factor (dB/m).
 2. Correction Factor (dB/m) = Antenna Factor (dB/m) + Cable Factor (dB).
 3. The other emission levels were very low against the limit.
 4. Margin value = Emission level – Limit value.
 5. “ * “: Fundamental frequency.



A D T

EUT TEST CONDITION		MEASUREMENT DETAIL	
CHANNEL	Channel 6	FREQUENCY RANGE	1 ~ 25GHz
INPUT POWER (SYSTEM)	120Vac, 60 Hz	DETECTOR FUNCTION	Peak (PK) Average (AV)
ENVIRONMENTAL CONDITIONS	22deg. C, 67%RH 1000hPa	TEST MODE	A
TESTED BY	Antony Lee		

ANTENNA POLARITY & TEST DISTANCE: HORIZONTAL AT 3 M								
NO.	FREQ. (MHz)	EMISSION LEVEL (dBuV/m)	LIMIT (dBuV/m)	MARGIN (dB)	ANTENNA HEIGHT (m)	TABLE ANGLE (Degree)	RAW VALUE (dBuV)	CORRECTION FACTOR (dB/m)
1	*2437.00	103.12 PK			1.36 H	33	69.84	33.28
2	*2437.00	99.34 AV			1.36 H	33	66.06	33.28
3	4874.00	47.23 PK	74.00	-26.77	1.06 H	120	8.09	39.14
4	4874.00	34.95 AV	54.00	-19.05	1.06 H	120	-4.19	39.14
ANTENNA POLARITY & TEST DISTANCE: VERTICAL AT 3 M								
NO.	FREQ. (MHz)	EMISSION LEVEL (dBuV/m)	LIMIT (dBuV/m)	MARGIN (dB)	ANTENNA HEIGHT (m)	TABLE ANGLE (Degree)	RAW VALUE (dBuV)	CORRECTION FACTOR (dB/m)
1	*2437.00	107.82 PK			1.41 V	49	74.54	33.28
2	*2437.00	103.50 AV			1.41 V	49	70.22	33.28
3	4874.00	47.62 PK	74.00	-26.38	1.00 V	157	8.48	39.14
4	4874.00	34.49 AV	54.00	-19.51	1.00 V	157	-4.65	39.14

- REMARKS:**
1. Emission level (dBuV/m) = Raw Value (dBuV) + Correction Factor (dB/m).
 2. Correction Factor (dB/m) = Antenna Factor (dB/m) + Cable Factor (dB).
 3. The other emission levels were very low against the limit.
 4. Margin value = Emission level – Limit value.
 5. “ * “: Fundamental frequency.

EUT TEST CONDITION		MEASUREMENT DETAIL	
CHANNEL	Channel 11	FREQUENCY RANGE	1 ~ 25GHz
INPUT POWER (SYSTEM)	120Vac, 60 Hz	DETECTOR FUNCTION	Peak (PK) Average (AV)
ENVIRONMENTAL CONDITIONS	22deg. C, 67%RH 1000hPa	TEST MODE	A
TESTED BY	Antony Lee		

ANTENNA POLARITY & TEST DISTANCE: HORIZONTAL AT 3 M								
NO.	FREQ. (MHz)	EMISSION LEVEL (dBuV/m)	LIMIT (dBuV/m)	MARGIN (dB)	ANTENNA HEIGHT (m)	TABLE ANGLE (Degree)	RAW VALUE (dBuV)	CORRECTION FACTOR (dB/m)
1	*2462.00	103.19 PK			1.04 H	22	69.81	33.38
2	*2462.00	99.72 AV			1.04 H	22	66.34	33.38
3	2483.50	61.12 PK	74.00	-12.88	1.05 H	26	27.66	33.46
4	2483.50	50.79 AV	54.00	-3.21	1.05 H	26	17.33	33.46
5	4924.00	47.64 PK	74.00	-26.36	1.08 H	111	8.28	39.35
6	4924.00	34.32 AV	54.00	-19.68	1.08 H	111	-5.04	39.35
ANTENNA POLARITY & TEST DISTANCE: VERTICAL AT 3 M								
NO.	FREQ. (MHz)	EMISSION LEVEL (dBuV/m)	LIMIT (dBuV/m)	MARGIN (dB)	ANTENNA HEIGHT (m)	TABLE ANGLE (Degree)	RAW VALUE (dBuV)	CORRECTION FACTOR (dB/m)
1	*2462.00	107.47 PK			1.13 V	44	74.09	33.38
2	*2462.00	103.23 AV			1.13 V	44	69.85	33.38
3	2483.50	62.89 PK	74.00	-11.11	1.12 V	29	29.43	33.46
4	2483.50	52.88 AV	54.00	-1.12	1.12 V	29	19.42	33.46
5	4924.00	46.79 PK	74.00	-27.21	1.00 V	166	7.43	39.35
6	4924.00	33.44 AV	54.00	-20.56	1.00 V	166	-5.92	39.35

- REMARKS:**
1. Emission level (dBuV/m) = Raw Value (dBuV) + Correction Factor (dB/m).
 2. Correction Factor (dB/m) = Antenna Factor (dB/m) + Cable Factor (dB).
 3. The other emission levels were very low against the limit.
 4. Margin value = Emission level – Limit value.
 5. “ * “: Fundamental frequency.

802.11g OFDM MODULATION: 1TX

EUT TEST CONDITION		MEASUREMENT DETAIL	
CHANNEL	Channel 1	FREQUENCY RANGE	1 ~ 25GHz
INPUT POWER (SYSTEM)	120Vac, 60 Hz	DETECTOR FUNCTION	Peak (PK) Average (AV)
ENVIRONMENTAL CONDITIONS	22deg. C, 67%RH 1000hPa	TEST MODE	A
TESTED BY	Antony Lee		

ANTENNA POLARITY & TEST DISTANCE: HORIZONTAL AT 3 M								
NO.	FREQ. (MHz)	EMISSION LEVEL (dBuV/m)	LIMIT (dBuV/m)	MARGIN (dB)	ANTENNA HEIGHT (m)	TABLE ANGLE (Degree)	RAW VALUE (dBuV)	CORRECTION FACTOR (dB/m)
1	2390.00	65.65 PK	74.00	-8.35	1.09 H	24	32.57	33.08
2	2390.00	51.30 AV	54.00	-2.70	1.09 H	24	18.22	33.08
3	*2412.00	103.52 PK			1.08 H	31	70.34	33.18
4	*2412.00	93.26 AV			1.08 H	31	60.08	33.18
5	4824.00	48.63 PK	74.00	-25.37	1.08 H	93	9.48	39.15
6	4824.00	34.15 AV	54.00	-19.85	1.08 H	93	-5.00	39.15
ANTENNA POLARITY & TEST DISTANCE: VERTICAL AT 3 M								
NO.	FREQ. (MHz)	EMISSION LEVEL (dBuV/m)	LIMIT (dBuV/m)	MARGIN (dB)	ANTENNA HEIGHT (m)	TABLE ANGLE (Degree)	RAW VALUE (dBuV)	CORRECTION FACTOR (dB/m)
1	2390.00	67.05 PK	74.00	-6.95	1.18 V	41	33.97	33.08
2	2390.00	52.38 AV	54.00	-1.62	1.18 V	41	19.30	33.08
3	*2412.00	107.48 PK			1.16 V	40	74.30	33.18
4	*2412.00	97.22 AV			1.16 V	40	64.04	33.18
5	4824.00	46.86 PK	74.00	-27.14	1.00 V	155	7.71	39.15
6	4824.00	33.92 AV	54.00	-20.08	1.00 V	155	-5.23	39.15

- REMARKS:**
1. Emission level (dBuV/m) = Raw Value (dBuV) + Correction Factor (dB/m).
 2. Correction Factor (dB/m) = Antenna Factor (dB/m) + Cable Factor (dB).
 3. The other emission levels were very low against the limit.
 4. Margin value = Emission level – Limit value.
 5. “ * “: Fundamental frequency.



A D T

EUT TEST CONDITION		MEASUREMENT DETAIL	
CHANNEL	Channel 6	FREQUENCY RANGE	1 ~ 25GHz
INPUT POWER (SYSTEM)	120Vac, 60 Hz	DETECTOR FUNCTION	Peak (PK) Average (AV)
ENVIRONMENTAL CONDITIONS	22deg. C, 67%RH 1000hPa	TEST MODE	A
TESTED BY	Antony Lee		

ANTENNA POLARITY & TEST DISTANCE: HORIZONTAL AT 3 M								
NO.	FREQ. (MHz)	EMISSION LEVEL (dBuV/m)	LIMIT (dBuV/m)	MARGIN (dB)	ANTENNA HEIGHT (m)	TABLE ANGLE (Degree)	RAW VALUE (dBuV)	CORRECTION FACTOR (dB/m)
1	*2437.00	104.28 PK			1.05 H	24	71.00	33.28
2	*2437.00	94.97 AV			1.05 H	24	61.69	33.28
3	4874.00	47.26 PK	74.00	-26.74	1.08 H	106	8.12	39.14
4	4874.00	35.74 AV	54.00	-18.26	1.08 H	106	-3.40	39.14
ANTENNA POLARITY & TEST DISTANCE: VERTICAL AT 3 M								
NO.	FREQ. (MHz)	EMISSION LEVEL (dBuV/m)	LIMIT (dBuV/m)	MARGIN (dB)	ANTENNA HEIGHT (m)	TABLE ANGLE (Degree)	RAW VALUE (dBuV)	CORRECTION FACTOR (dB/m)
1	*2437.00	108.00 PK			1.15 V	36	74.72	33.28
2	*2437.00	98.00 AV			1.15 V	36	64.72	33.28
3	4874.00	46.46 PK	74.00	-27.54	1.00 V	142	7.32	39.14
4	4874.00	35.79 AV	54.00	-18.21	1.00 V	142	-3.35	39.14

- REMARKS:**
1. Emission level (dBuV/m) = Raw Value (dBuV) + Correction Factor (dB/m).
 2. Correction Factor (dB/m) = Antenna Factor (dB/m) + Cable Factor (dB).
 3. The other emission levels were very low against the limit.
 4. Margin value = Emission level – Limit value.
 5. “ * “: Fundamental frequency.

EUT TEST CONDITION		MEASUREMENT DETAIL	
CHANNEL	Channel 11	FREQUENCY RANGE	1 ~ 25GHz
INPUT POWER (SYSTEM)	120Vac, 60 Hz	DETECTOR FUNCTION	Peak (PK) Average (AV)
ENVIRONMENTAL CONDITIONS	22deg. C, 67%RH 1000hPa	TEST MODE	A
TESTED BY	Antony Lee		

ANTENNA POLARITY & TEST DISTANCE: HORIZONTAL AT 3 M								
NO.	FREQ. (MHz)	EMISSION LEVEL (dBuV/m)	LIMIT (dBuV/m)	MARGIN (dB)	ANTENNA HEIGHT (m)	TABLE ANGLE (Degree)	RAW VALUE (dBuV)	CORRECTION FACTOR (dB/m)
1	*2462.00	103.00 PK			1.03 H	31	69.62	33.38
2	*2462.00	93.00 AV			1.03 H	31	59.62	33.38
3	2483.50	62.02 PK	74.00	-11.98	1.04 H	30	28.56	33.46
4	2483.50	51.79 AV	54.00	-2.21	1.04 H	30	18.33	33.46
5	4924.00	47.62 PK	74.00	-26.38	1.09 H	120	8.27	39.35
6	4924.00	34.88 AV	54.00	-19.12	1.09 H	120	-4.47	39.35
ANTENNA POLARITY & TEST DISTANCE: VERTICAL AT 3 M								
NO.	FREQ. (MHz)	EMISSION LEVEL (dBuV/m)	LIMIT (dBuV/m)	MARGIN (dB)	ANTENNA HEIGHT (m)	TABLE ANGLE (Degree)	RAW VALUE (dBuV)	CORRECTION FACTOR (dB/m)
1	*2462.00	107.84 PK			1.17 V	43	74.46	33.38
2	*2462.00	97.64 AV			1.17 V	43	64.26	33.38
3	2483.50	63.97 PK	74.00	-10.03	1.13 V	30	30.51	33.46
4	2483.50	52.42 AV	54.00	-1.58	1.13 V	30	18.96	33.46
5	4924.00	46.61 PK	74.00	-27.39	1.00 V	126	7.26	39.35
6	4924.00	34.38 AV	54.00	-19.62	1.00 V	126	-4.97	39.35

- REMARKS:**
1. Emission level (dBuV/m) = Raw Value (dBuV) + Correction Factor (dB/m).
 2. Correction Factor (dB/m) = Antenna Factor (dB/m) + Cable Factor (dB).
 3. The other emission levels were very low against the limit.
 4. Margin value = Emission level – Limit value.
 5. “ * “: Fundamental frequency.

DRAFT 802.11n (20MHz) OFDM MODULATION: 1TX

EUT TEST CONDITION		MEASUREMENT DETAIL	
CHANNEL	Channel 1	FREQUENCY RANGE	1 ~ 25GHz
INPUT POWER (SYSTEM)	120Vac, 60 Hz	DETECTOR FUNCTION	Peak (PK) Average (AV)
ENVIRONMENTAL CONDITIONS	22deg. C, 67%RH 1000hPa	TEST MODE	A
TESTED BY	Antony Lee		

ANTENNA POLARITY & TEST DISTANCE: HORIZONTAL AT 3 M								
NO.	FREQ. (MHz)	EMISSION LEVEL (dBuV/m)	LIMIT (dBuV/m)	MARGIN (dB)	ANTENNA HEIGHT (m)	TABLE ANGLE (Degree)	RAW VALUE (dBuV)	CORRECTION FACTOR (dB/m)
1	2390.00	65.19 PK	74.00	-8.81	1.12 H	29	32.11	33.08
2	2390.00	51.49 AV	54.00	-2.51	1.12 H	29	18.41	33.08
3	*2412.00	102.28 PK			1.09 H	27	69.10	33.18
4	*2412.00	92.70 AV			1.09 H	27	59.52	33.18
5	4824.00	49.62 PK	74.00	-24.38	1.06 H	88	10.47	39.15
6	4824.00	34.51 AV	54.00	-19.49	1.06 H	88	-4.64	39.15
ANTENNA POLARITY & TEST DISTANCE: VERTICAL AT 3 M								
NO.	FREQ. (MHz)	EMISSION LEVEL (dBuV/m)	LIMIT (dBuV/m)	MARGIN (dB)	ANTENNA HEIGHT (m)	TABLE ANGLE (Degree)	RAW VALUE (dBuV)	CORRECTION FACTOR (dB/m)
1	2390.00	67.60 PK	74.00	-6.40	1.21 V	45	34.52	33.08
2	2390.00	52.98 AV	54.00	-1.02	1.21 V	45	19.90	33.08
3	*2412.00	106.17 PK			1.18 V	43	72.99	33.18
4	*2412.00	96.97 AV			1.18 V	43	63.79	33.18
5	4824.00	46.88 PK	74.00	-27.12	1.00 V	166	7.73	39.15
6	4824.00	33.26 AV	54.00	-20.74	1.00 V	166	-5.89	39.15

- REMARKS:**
1. Emission level (dBuV/m) = Raw Value (dBuV) + Correction Factor (dB/m).
 2. Correction Factor (dB/m) = Antenna Factor (dB/m) + Cable Factor (dB).
 3. The other emission levels were very low against the limit.
 4. Margin value = Emission level – Limit value.
 5. “ * “: Fundamental frequency.

EUT TEST CONDITION		MEASUREMENT DETAIL	
CHANNEL	Channel 6	FREQUENCY RANGE	1 ~ 25GHz
INPUT POWER (SYSTEM)	120Vac, 60 Hz	DETECTOR FUNCTION	Peak (PK) Average (AV)
ENVIRONMENTAL CONDITIONS	22deg. C, 67%RH 1000hPa	TEST MODE	A
TESTED BY	Antony Lee		

ANTENNA POLARITY & TEST DISTANCE: HORIZONTAL AT 3 M								
NO.	FREQ. (MHz)	EMISSION LEVEL (dBuV/m)	LIMIT (dBuV/m)	MARGIN (dB)	ANTENNA HEIGHT (m)	TABLE ANGLE (Degree)	RAW VALUE (dBuV)	CORRECTION FACTOR (dB/m)
1	*2437.00	103.26 PK			1.04 H	33	69.98	33.28
2	*2437.00	93.87 AV			1.04 H	33	60.59	33.28
3	4874.00	48.51 PK	74.00	-25.49	1.02 H	111	9.37	39.14
4	4874.00	35.18 AV	54.00	-18.82	1.02 H	111	-3.96	39.14
ANTENNA POLARITY & TEST DISTANCE: VERTICAL AT 3 M								
NO.	FREQ. (MHz)	EMISSION LEVEL (dBuV/m)	LIMIT (dBuV/m)	MARGIN (dB)	ANTENNA HEIGHT (m)	TABLE ANGLE (Degree)	RAW VALUE (dBuV)	CORRECTION FACTOR (dB/m)
1	*2437.00	107.15 PK			1.14 V	40	73.87	33.28
2	*2437.00	97.32 AV			1.14 V	40	64.04	33.28
3	4874.00	46.58 PK	74.00	-27.42	1.02 V	166	7.44	39.14
4	4874.00	36.15 AV	54.00	-17.85	1.02 V	166	-2.99	39.14

- REMARKS:**
1. Emission level (dBuV/m) = Raw Value (dBuV) + Correction Factor (dB/m).
 2. Correction Factor (dB/m) = Antenna Factor (dB/m) + Cable Factor (dB).
 3. The other emission levels were very low against the limit.
 4. Margin value = Emission level – Limit value.
 5. “ * “: Fundamental frequency.



A D T

EUT TEST CONDITION		MEASUREMENT DETAIL	
CHANNEL	Channel 11	FREQUENCY RANGE	1 ~ 25GHz
INPUT POWER (SYSTEM)	120Vac, 60 Hz	DETECTOR FUNCTION	Peak (PK) Average (AV)
ENVIRONMENTAL CONDITIONS	22deg. C, 67%RH 1000hPa	TEST MODE	A
TESTED BY	Antony Lee		

ANTENNA POLARITY & TEST DISTANCE: HORIZONTAL AT 3 M								
NO.	FREQ. (MHz)	EMISSION LEVEL (dBuV/m)	LIMIT (dBuV/m)	MARGIN (dB)	ANTENNA HEIGHT (m)	TABLE ANGLE (Degree)	RAW VALUE (dBuV)	CORRECTION FACTOR (dB/m)
1	*2462.00	102.62 PK			1.02 H	42	69.24	33.38
2	*2462.00	92.48 AV			1.02 H	42	59.10	33.38
3	2483.50	62.16 PK	74.00	-11.84	1.04 H	52	28.70	33.46
4	2483.50	51.62 AV	54.00	-2.38	1.04 H	52	18.16	33.46
5	4924.00	46.88 PK	74.00	-27.12	1.10 H	121	7.53	39.35
6	4924.00	35.62 AV	54.00	-18.38	1.10 H	121	-3.73	39.35
ANTENNA POLARITY & TEST DISTANCE: VERTICAL AT 3 M								
NO.	FREQ. (MHz)	EMISSION LEVEL (dBuV/m)	LIMIT (dBuV/m)	MARGIN (dB)	ANTENNA HEIGHT (m)	TABLE ANGLE (Degree)	RAW VALUE (dBuV)	CORRECTION FACTOR (dB/m)
1	*2462.00	106.02 PK			1.16 V	46	72.64	33.38
2	*2462.00	96.62 AV			1.16 V	46	63.24	33.38
3	2483.50	64.23 PK	74.00	-9.77	1.15 V	38	30.77	33.46
4	2483.50	52.33 AV	54.00	-1.67	1.15 V	38	18.87	33.46
5	4924.00	46.31 PK	74.00	-27.69	1.00 V	102	6.96	39.35
6	4924.00	35.62 AV	54.00	-18.38	1.00 V	102	-3.73	39.35

- REMARKS:**
1. Emission level (dBuV/m) = Raw Value (dBuV) + Correction Factor (dB/m).
 2. Correction Factor (dB/m) = Antenna Factor (dB/m) + Cable Factor (dB).
 3. The other emission levels were very low against the limit.
 4. Margin value = Emission level – Limit value.
 5. “ * “: Fundamental frequency.



A D T

DRAFT 802.11n (20MHz) OFDM MODULATION: 2TX

EUT TEST CONDITION		MEASUREMENT DETAIL	
CHANNEL	Channel 1	FREQUENCY RANGE	1 ~ 25GHz
INPUT POWER (SYSTEM)	120Vac, 60 Hz	DETECTOR FUNCTION	Peak (PK) Average (AV)
ENVIRONMENTAL CONDITIONS	22deg. C, 67%RH 1000hPa	TEST MODE	A
TESTED BY	Antony Lee		

ANTENNA POLARITY & TEST DISTANCE: HORIZONTAL AT 3 M								
NO.	FREQ. (MHz)	EMISSION LEVEL (dBuV/m)	LIMIT (dBuV/m)	MARGIN (dB)	ANTENNA HEIGHT (m)	TABLE ANGLE (Degree)	RAW VALUE (dBuV)	CORRECTION FACTOR (dB/m)
1	2390.00	64.74 PK	74.00	-9.26	1.31 H	256	31.66	33.08
2	2390.00	50.34 AV	54.00	-3.66	1.31 H	256	17.26	33.08
3	*2412.00	104.54 PK			1.29 H	255	71.36	33.18
4	*2412.00	94.28 AV			1.29 H	255	61.10	33.18
5	4824.00	47.49 PK	74.00	-26.51	1.05 H	91	8.34	39.15
6	4824.00	33.87 AV	54.00	-20.13	1.05 H	91	-5.28	39.15
ANTENNA POLARITY & TEST DISTANCE: VERTICAL AT 3 M								
NO.	FREQ. (MHz)	EMISSION LEVEL (dBuV/m)	LIMIT (dBuV/m)	MARGIN (dB)	ANTENNA HEIGHT (m)	TABLE ANGLE (Degree)	RAW VALUE (dBuV)	CORRECTION FACTOR (dB/m)
1	2390.00	66.62 PK	74.00	-7.38	1.00 V	192	33.54	33.08
2	2390.00	52.47 AV	54.00	-1.53	1.00 V	192	19.39	33.08
3	*2412.00	109.15 PK			1.00 V	191	75.97	33.18
4	*2412.00	99.29 AV			1.00 V	191	66.11	33.18
5	4824.00	48.04 PK	74.00	-25.96	1.10 V	85	8.89	39.15
6	4824.00	34.16 AV	54.00	-19.84	1.10 V	85	-4.99	39.15

- REMARKS:**
1. Emission level (dBuV/m) = Raw Value (dBuV) + Correction Factor (dB/m).
 2. Correction Factor (dB/m) = Antenna Factor (dB/m) + Cable Factor (dB).
 3. The other emission levels were very low against the limit.
 4. Margin value = Emission level – Limit value.
 5. “ * “: Fundamental frequency.

EUT TEST CONDITION		MEASUREMENT DETAIL	
CHANNEL	Channel 6	FREQUENCY RANGE	1 ~ 25GHz
INPUT POWER (SYSTEM)	120Vac, 60 Hz	DETECTOR FUNCTION	Peak (PK) Average (AV)
ENVIRONMENTAL CONDITIONS	22deg. C, 67%RH 1000hPa	TEST MODE	A
TESTED BY	Antony Lee		

ANTENNA POLARITY & TEST DISTANCE: HORIZONTAL AT 3 M								
NO.	FREQ. (MHz)	EMISSION LEVEL (dBuV/m)	LIMIT (dBuV/m)	MARGIN (dB)	ANTENNA HEIGHT (m)	TABLE ANGLE (Degree)	RAW VALUE (dBuV)	CORRECTION FACTOR (dB/m)
1	*2437.00	104.98 PK			1.26 H	241	71.70	33.28
2	*2437.00	94.77 AV			1.26 H	241	61.49	33.28
3	4874.00	46.88 PK	74.00	-27.12	1.01 H	59	7.74	39.14
4	4874.00	34.51 AV	54.00	-19.49	1.01 H	59	-4.63	39.14
ANTENNA POLARITY & TEST DISTANCE: VERTICAL AT 3 M								
NO.	FREQ. (MHz)	EMISSION LEVEL (dBuV/m)	LIMIT (dBuV/m)	MARGIN (dB)	ANTENNA HEIGHT (m)	TABLE ANGLE (Degree)	RAW VALUE (dBuV)	CORRECTION FACTOR (dB/m)
1	*2437.00	109.67 PK			1.00 V	21	76.39	33.28
2	*2437.00	99.81 AV			1.00 V	21	66.53	33.28
3	4874.00	48.62 PK	74.00	-25.38	1.02 V	155	9.48	39.14
4	4874.00	35.61 AV	54.00	-18.39	1.02 V	155	-3.53	39.14

- REMARKS:**
1. Emission level (dBuV/m) = Raw Value (dBuV) + Correction Factor (dB/m).
 2. Correction Factor (dB/m) = Antenna Factor (dB/m) + Cable Factor (dB).
 3. The other emission levels were very low against the limit.
 4. Margin value = Emission level – Limit value.
 5. “ * ”: Fundamental frequency.



A D T

EUT TEST CONDITION		MEASUREMENT DETAIL	
CHANNEL	Channel 11	FREQUENCY RANGE	1 ~ 25GHz
INPUT POWER (SYSTEM)	120Vac, 60 Hz	DETECTOR FUNCTION	Peak (PK) Average (AV)
ENVIRONMENTAL CONDITIONS	22deg. C, 67%RH 1000hPa	TEST MODE	A
TESTED BY	Antony Lee		

ANTENNA POLARITY & TEST DISTANCE: HORIZONTAL AT 3 M								
NO.	FREQ. (MHz)	EMISSION LEVEL (dBuV/m)	LIMIT (dBuV/m)	MARGIN (dB)	ANTENNA HEIGHT (m)	TABLE ANGLE (Degree)	RAW VALUE (dBuV)	CORRECTION FACTOR (dB/m)
1	*2462.00	103.49 PK			1.23 H	239	70.11	33.38
2	*2462.00	93.25 AV			1.23 H	239	59.87	33.38
3	2483.50	62.15 PK	74.00	-11.85	1.22 H	230	28.69	33.46
4	2483.50	48.77 AV	54.00	-5.23	1.22 H	230	15.31	33.46
5	4924.00	48.62 PK	74.00	-25.38	1.10 H	106	9.27	39.35
6	4924.00	34.10 AV	54.00	-19.90	1.10 H	106	-5.25	39.35
ANTENNA POLARITY & TEST DISTANCE: VERTICAL AT 3 M								
NO.	FREQ. (MHz)	EMISSION LEVEL (dBuV/m)	LIMIT (dBuV/m)	MARGIN (dB)	ANTENNA HEIGHT (m)	TABLE ANGLE (Degree)	RAW VALUE (dBuV)	CORRECTION FACTOR (dB/m)
1	*2462.00	108.17 PK			1.00 V	183	74.79	33.38
2	*2462.00	98.21 AV			1.00 V	183	64.83	33.38
3	2483.50	69.61 PK	74.00	-4.39	1.00 V	201	36.15	33.46
4	2483.50	52.74 AV	54.00	-1.26	1.00 V	201	19.28	33.46
5	4924.00	46.58 PK	74.00	-27.42	1.11 V	93	7.23	39.35
6	4924.00	35.21 AV	54.00	-18.79	1.11 V	93	-4.14	39.35

- REMARKS:**
1. Emission level (dBuV/m) = Raw Value (dBuV) + Correction Factor (dB/m).
 2. Correction Factor (dB/m) = Antenna Factor (dB/m) + Cable Factor (dB).
 3. The other emission levels were very low against the limit.
 4. Margin value = Emission level – Limit value.
 5. “ * “: Fundamental frequency.

DRAFT 802.11n (40MHz) OFDM MODULATION: 1TX

EUT TEST CONDITION		MEASUREMENT DETAIL	
CHANNEL	Channel 1	FREQUENCY RANGE	1 ~ 25GHz
INPUT POWER (SYSTEM)	120Vac, 60 Hz	DETECTOR FUNCTION	Peak (PK) Average (AV)
ENVIRONMENTAL CONDITIONS	22deg. C, 67%RH 1000hPa	TEST MODE	A
TESTED BY	Antony Lee		

ANTENNA POLARITY & TEST DISTANCE: HORIZONTAL AT 3 M								
NO.	FREQ. (MHz)	EMISSION LEVEL (dBuV/m)	LIMIT (dBuV/m)	MARGIN (dB)	ANTENNA HEIGHT (m)	TABLE ANGLE (Degree)	RAW VALUE (dBuV)	CORRECTION FACTOR (dB/m)
1	2390.00	62.04 PK	74.00	-11.96	1.09 H	19	28.96	33.08
2	2390.00	51.49 AV	54.00	-2.51	1.09 H	19	18.41	33.08
3	*2422.00	99.59 PK			1.07 H	24	66.37	33.22
4	*2422.00	90.38 AV			1.07 H	24	57.16	33.22
5	4844.00	46.45 PK	74.00	-27.55	1.05 H	106	7.31	39.15
6	4844.00	33.41 AV	54.00	-20.59	1.05 H	106	-5.73	39.15
ANTENNA POLARITY & TEST DISTANCE: VERTICAL AT 3 M								
NO.	FREQ. (MHz)	EMISSION LEVEL (dBuV/m)	LIMIT (dBuV/m)	MARGIN (dB)	ANTENNA HEIGHT (m)	TABLE ANGLE (Degree)	RAW VALUE (dBuV)	CORRECTION FACTOR (dB/m)
1	2390.00	64.60 PK	74.00	-9.40	1.20 V	42	31.52	33.08
2	2390.00	52.81 AV	54.00	-1.19	1.20 V	42	19.73	33.08
3	*2422.00	103.69 PK			1.18 V	30	70.47	33.22
4	*2422.00	94.39 AV			1.18 V	30	61.17	33.22
5	4844.00	46.63 PK	74.00	-27.37	1.00 V	175	7.49	39.15
6	4844.00	33.66 AV	54.00	-20.34	1.00 V	175	-5.48	39.15

- REMARKS:**
1. Emission level (dBuV/m) = Raw Value (dBuV) + Correction Factor (dB/m).
 2. Correction Factor (dB/m) = Antenna Factor (dB/m) + Cable Factor (dB).
 3. The other emission levels were very low against the limit.
 4. Margin value = Emission level – Limit value.
 5. “ * “: Fundamental frequency.



A D T

EUT TEST CONDITION		MEASUREMENT DETAIL	
CHANNEL	Channel 4	FREQUENCY RANGE	1 ~ 25GHz
INPUT POWER (SYSTEM)	120Vac, 60 Hz	DETECTOR FUNCTION	Peak (PK) Average (AV)
ENVIRONMENTAL CONDITIONS	22deg. C, 67%RH 1000hPa	TEST MODE	A
TESTED BY	Antony Lee		

ANTENNA POLARITY & TEST DISTANCE: HORIZONTAL AT 3 M								
NO.	FREQ. (MHz)	EMISSION LEVEL (dBuV/m)	LIMIT (dBuV/m)	MARGIN (dB)	ANTENNA HEIGHT (m)	TABLE ANGLE (Degree)	RAW VALUE (dBuV)	CORRECTION FACTOR (dB/m)
1	*2437.00	100.67 PK			1.07 H	27	67.39	33.28
2	*2437.00	91.54 AV			1.07 H	27	58.26	33.28
3	4874.00	46.95 PK	74.00	-27.05	1.02 H	132	7.81	39.14
4	4874.00	34.62 AV	54.00	-19.38	1.02 H	132	-4.52	39.14
ANTENNA POLARITY & TEST DISTANCE: VERTICAL AT 3 M								
NO.	FREQ. (MHz)	EMISSION LEVEL (dBuV/m)	LIMIT (dBuV/m)	MARGIN (dB)	ANTENNA HEIGHT (m)	TABLE ANGLE (Degree)	RAW VALUE (dBuV)	CORRECTION FACTOR (dB/m)
1	*2437.00	104.73 PK			1.20 V	42	71.45	33.28
2	*2437.00	95.47 AV			1.20 V	42	62.19	33.28
3	4874.00	46.51 PK	74.00	-27.49	1.00 V	166	7.37	39.14
4	4874.00	33.95 AV	54.00	-20.05	1.00 V	166	-5.19	39.14

- REMARKS:**
1. Emission level (dBuV/m) = Raw Value (dBuV) + Correction Factor (dB/m).
 2. Correction Factor (dB/m) = Antenna Factor (dB/m) + Cable Factor (dB).
 3. The other emission levels were very low against the limit.
 4. Margin value = Emission level – Limit value.
 5. “ * “: Fundamental frequency.

EUT TEST CONDITION		MEASUREMENT DETAIL	
CHANNEL	Channel 7	FREQUENCY RANGE	1 ~ 25GHz
INPUT POWER (SYSTEM)	120Vac, 60 Hz	DETECTOR FUNCTION	Peak (PK) Average (AV)
ENVIRONMENTAL CONDITIONS	22deg. C, 67%RH 1000hPa	TEST MODE	A
TESTED BY	Antony Lee		

ANTENNA POLARITY & TEST DISTANCE: HORIZONTAL AT 3 M								
NO.	FREQ. (MHz)	EMISSION LEVEL (dBuV/m)	LIMIT (dBuV/m)	MARGIN (dB)	ANTENNA HEIGHT (m)	TABLE ANGLE (Degree)	RAW VALUE (dBuV)	CORRECTION FACTOR (dB/m)
1	*2452.00	99.68 PK			1.05 H	23	66.34	33.34
2	*2452.00	90.45 AV			1.05 H	23	57.11	33.34
3	2483.50	59.65 PK	74.00	-14.35	1.07 H	24	26.19	33.46
4	2483.50	50.56 AV	54.00	-3.44	1.07 H	24	17.10	33.46
5	4904.00	46.52 PK	74.00	-27.48	1.04 H	121	7.34	39.18
6	4904.00	34.31 AV	54.00	-19.69	1.04 H	121	-4.87	39.18
ANTENNA POLARITY & TEST DISTANCE: VERTICAL AT 3 M								
NO.	FREQ. (MHz)	EMISSION LEVEL (dBuV/m)	LIMIT (dBuV/m)	MARGIN (dB)	ANTENNA HEIGHT (m)	TABLE ANGLE (Degree)	RAW VALUE (dBuV)	CORRECTION FACTOR (dB/m)
1	*2452.00	103.74 PK			1.17 V	46	70.40	33.34
2	*2452.00	94.48 AV			1.17 V	46	61.14	33.34
3	2483.50	63.32 PK	74.00	-10.68	1.14 V	29	29.86	33.46
4	2483.50	52.41 AV	54.00	-1.59	1.14 V	29	18.95	33.46
5	4904.00	46.88 PK	74.00	-27.12	1.00 V	181	7.70	39.18
6	4904.00	34.51 AV	54.00	-19.49	1.00 V	181	-4.67	39.18

- REMARKS:**
1. Emission level (dBuV/m) = Raw Value (dBuV) + Correction Factor (dB/m).
 2. Correction Factor (dB/m) = Antenna Factor (dB/m) + Cable Factor (dB).
 3. The other emission levels were very low against the limit.
 4. Margin value = Emission level – Limit value.
 5. “ * “: Fundamental frequency.

DRAFT 802.11n (40MHz) OFDM MODULATION: 2TX

EUT TEST CONDITION		MEASUREMENT DETAIL	
CHANNEL	Channel 1	FREQUENCY RANGE	1 ~ 25GHz
INPUT POWER (SYSTEM)	120Vac, 60 Hz	DETECTOR FUNCTION	Peak (PK) Average (AV)
ENVIRONMENTAL CONDITIONS	22deg. C, 67%RH 1000hPa	TEST MODE	A
TESTED BY	Antony Lee		

ANTENNA POLARITY & TEST DISTANCE: HORIZONTAL AT 3 M								
NO.	FREQ. (MHz)	EMISSION LEVEL (dBuV/m)	LIMIT (dBuV/m)	MARGIN (dB)	ANTENNA HEIGHT (m)	TABLE ANGLE (Degree)	RAW VALUE (dBuV)	CORRECTION FACTOR (dB/m)
1	2390.00	63.15 PK	74.00	-10.85	1.33 H	256	30.07	33.08
2	2390.00	50.23 AV	54.00	-3.77	1.33 H	256	17.15	33.08
3	*2422.00	101.73 PK			1.34 H	255	68.51	33.22
4	*2422.00	91.50 AV			1.34 H	255	58.28	33.22
5	4844.00	47.88 PK	74.00	-26.12	1.12 H	99	8.73	39.15
6	4844.00	35.69 AV	54.00	-18.31	1.12 H	99	-3.46	39.15
ANTENNA POLARITY & TEST DISTANCE: VERTICAL AT 3 M								
NO.	FREQ. (MHz)	EMISSION LEVEL (dBuV/m)	LIMIT (dBuV/m)	MARGIN (dB)	ANTENNA HEIGHT (m)	TABLE ANGLE (Degree)	RAW VALUE (dBuV)	CORRECTION FACTOR (dB/m)
1	2390.00	66.62 PK	74.00	-7.38	1.12 V	201	33.54	33.08
2	2390.00	52.66 AV	54.00	-1.34	1.12 V	201	19.58	33.08
3	*2422.00	105.52 PK			1.12 V	231	72.30	33.22
4	*2422.00	95.64 AV			1.12 V	231	62.42	33.22
5	4844.00	48.62 PK	74.00	-25.38	1.02 V	63	9.47	39.15
6	4844.00	35.67 AV	54.00	-18.33	1.02 V	63	-3.48	39.15

- REMARKS:**
1. Emission level (dBuV/m) = Raw Value (dBuV) + Correction Factor (dB/m).
 2. Correction Factor (dB/m) = Antenna Factor (dB/m) + Cable Factor (dB).
 3. The other emission levels were very low against the limit.
 4. Margin value = Emission level – Limit value.
 5. “ * “: Fundamental frequency.

EUT TEST CONDITION		MEASUREMENT DETAIL	
CHANNEL	Channel 4	FREQUENCY RANGE	1 ~ 25GHz
INPUT POWER (SYSTEM)	120Vac, 60 Hz	DETECTOR FUNCTION	Peak (PK) Average (AV)
ENVIRONMENTAL CONDITIONS	22deg. C, 67%RH 1000hPa	TEST MODE	A
TESTED BY	Antony Lee		

ANTENNA POLARITY & TEST DISTANCE: HORIZONTAL AT 3 M								
NO.	FREQ. (MHz)	EMISSION LEVEL (dBuV/m)	LIMIT (dBuV/m)	MARGIN (dB)	ANTENNA HEIGHT (m)	TABLE ANGLE (Degree)	RAW VALUE (dBuV)	CORRECTION FACTOR (dB/m)
1	*2437.00	103.12 PK			1.23 H	206	69.84	33.28
2	*2437.00	93.24 AV			1.23 H	206	59.96	33.28
3	4874.00	46.48 PK	74.00	-27.52	1.09 H	88	7.34	39.14
4	4874.00	35.62 AV	54.00	-18.38	1.09 H	88	-3.52	39.14
ANTENNA POLARITY & TEST DISTANCE: VERTICAL AT 3 M								
NO.	FREQ. (MHz)	EMISSION LEVEL (dBuV/m)	LIMIT (dBuV/m)	MARGIN (dB)	ANTENNA HEIGHT (m)	TABLE ANGLE (Degree)	RAW VALUE (dBuV)	CORRECTION FACTOR (dB/m)
1	*2437.00	107.02 PK			1.16 V	236	73.74	33.28
2	*2437.00	97.09 AV			1.16 V	236	63.81	33.28
3	4874.00	48.62 PK	74.00	-25.38	1.05 V	71	9.48	39.14
4	4874.00	35.66 AV	54.00	-18.34	1.05 V	71	-3.48	39.14

- REMARKS:**
1. Emission level (dBuV/m) = Raw Value (dBuV) + Correction Factor (dB/m).
 2. Correction Factor (dB/m) = Antenna Factor (dB/m) + Cable Factor (dB).
 3. The other emission levels were very low against the limit.
 4. Margin value = Emission level – Limit value.
 5. “ * “: Fundamental frequency.



A D T

EUT TEST CONDITION		MEASUREMENT DETAIL	
CHANNEL	Channel 7	FREQUENCY RANGE	1 ~ 25GHz
INPUT POWER (SYSTEM)	120Vac, 60 Hz	DETECTOR FUNCTION	Peak (PK) Average (AV)
ENVIRONMENTAL CONDITIONS	22deg. C, 67%RH 1000hPa	TEST MODE	A
TESTED BY	Antony Lee		

ANTENNA POLARITY & TEST DISTANCE: HORIZONTAL AT 3 M								
NO.	FREQ. (MHz)	EMISSION LEVEL (dBuV/m)	LIMIT (dBuV/m)	MARGIN (dB)	ANTENNA HEIGHT (m)	TABLE ANGLE (Degree)	RAW VALUE (dBuV)	CORRECTION FACTOR (dB/m)
1	*2452.00	101.20 PK			1.26 H	261	67.86	33.34
2	*2452.00	91.62 AV			1.26 H	261	58.28	33.34
3	2483.50	60.32 PK	74.00	-13.68	1.01 H	266	26.86	33.46
4	2483.50	49.26 AV	54.00	-4.74	1.01 H	266	15.80	33.46
5	4904.00	46.92 PK	74.00	-27.08	1.20 H	131	7.74	39.18
6	4904.00	35.62 AV	54.00	-18.38	1.20 H	131	-3.56	39.18
ANTENNA POLARITY & TEST DISTANCE: VERTICAL AT 3 M								
NO.	FREQ. (MHz)	EMISSION LEVEL (dBuV/m)	LIMIT (dBuV/m)	MARGIN (dB)	ANTENNA HEIGHT (m)	TABLE ANGLE (Degree)	RAW VALUE (dBuV)	CORRECTION FACTOR (dB/m)
1	*2452.00	105.62 PK			1.08 V	236	72.28	33.34
2	*2452.00	95.58 AV			1.08 V	236	62.24	33.34
3	2483.50	66.48 PK	74.00	-7.52	1.09 V	233	33.02	33.46
4	2483.50	52.33 AV	54.00	-1.67	1.09 V	233	18.87	33.46
5	4904.00	48.62 PK	74.00	-25.38	1.03 V	46	9.44	39.18
6	4904.00	35.62 AV	54.00	-18.38	1.03 V	46	-3.56	39.18

- REMARKS:**
1. Emission level (dBuV/m) = Raw Value (dBuV) + Correction Factor (dB/m).
 2. Correction Factor (dB/m) = Antenna Factor (dB/m) + Cable Factor (dB).
 3. The other emission levels were very low against the limit.
 4. Margin value = Emission level – Limit value.
 5. “ * “: Fundamental frequency.

BELOW 1GHz WORST-CASE DATA : DRAFT 802.11n (20MHz) OFDM MODULATION: 2TX

EUT TEST CONDITION		MEASUREMENT DETAIL	
CHANNEL	Channel 6	FREQUENCY RANGE	Below 1000MHz
INPUT POWER (SYSTEM)	120Vac, 60 Hz	DETECTOR FUNCTION	Quasi-Peak
ENVIRONMENTAL CONDITIONS	26deg. C, 66%RH 999hPa	TEST MODE	A
TESTED BY	Antony Lee		

ANTENNA POLARITY & TEST DISTANCE: HORIZONTAL AT 3 M								
NO.	FREQ. (MHz)	EMISSION LEVEL (dBuV/m)	LIMIT (dBuV/m)	MARGIN (dB)	ANTENNA HEIGHT (m)	TABLE ANGLE (Degree)	RAW VALUE (dBuV)	CORRECTION FACTOR (dB/m)
1	479.03	40.66 QP	46.00	-5.34	2.00 H	283	20.80	19.86
2	500.42	43.39 QP	46.00	-2.61	2.00 H	280	22.89	20.50
3	720.12	40.10 QP	46.00	-5.90	1.25 H	46	14.62	25.49
4	797.89	36.95 QP	46.00	-9.05	2.00 H	268	10.59	26.36
5	904.83	37.42 QP	46.00	-8.58	1.50 H	256	9.28	28.14
6	951.49	36.88 QP	46.00	-9.12	1.25 H	46	8.18	28.70
ANTENNA POLARITY & TEST DISTANCE: VERTICAL AT 3 M								
NO.	FREQ. (MHz)	EMISSION LEVEL (dBuV/m)	LIMIT (dBuV/m)	MARGIN (dB)	ANTENNA HEIGHT (m)	TABLE ANGLE (Degree)	RAW VALUE (dBuV)	CORRECTION FACTOR (dB/m)
1	31.84	32.98 QP	40.00	-7.02	1.00 V	100	20.41	12.57
2	480.97	34.60 QP	46.00	-11.40	2.00 V	295	14.68	19.92
3	720.12	33.10 QP	46.00	-12.90	1.25 V	310	7.61	25.49
4	797.89	35.50 QP	46.00	-10.50	1.25 V	307	9.14	26.36
5	871.78	34.33 QP	46.00	-11.67	1.50 V	358	6.68	27.64
6	951.49	39.24 QP	46.00	-6.76	1.00 V	202	10.54	28.70

- REMARKS:**
1. Emission level (dBuV/m) = Raw Value (dBuV) + Correction Factor (dB/m).
 2. Correction Factor (dB/m) = Antenna Factor (dB/m) + Cable Factor (dB).
 3. The other emission levels were very low against the limit.
 4. Margin value = Emission level – Limit value.

EUT TEST CONDITION		MEASUREMENT DETAIL	
CHANNEL	Channel 6	FREQUENCY RANGE	Below 1000MHz
INPUT POWER (SYSTEM)	120Vac, 60 Hz	DETECTOR FUNCTION	Quasi-Peak
ENVIRONMENTAL CONDITIONS	26deg. C, 66%RH 999hPa	TEST MODE	B
TESTED BY	Antony Lee		

ANTENNA POLARITY & TEST DISTANCE: HORIZONTAL AT 3 M								
NO.	FREQ. (MHz)	EMISSION LEVEL (dBuV/m)	LIMIT (dBuV/m)	MARGIN (dB)	ANTENNA HEIGHT (m)	TABLE ANGLE (Degree)	RAW VALUE (dBuV)	CORRECTION FACTOR (dB/m)
1	239.88	38.04 QP	46.00	-7.96	1.00 H	196	24.83	13.21
2	360.43	40.43 QP	46.00	-5.57	1.00 H	10	24.11	16.31
3	720.12	39.61 QP	46.00	-6.39	1.00 H	268	14.13	25.49
4	797.89	37.03 QP	46.00	-8.97	1.00 H	64	10.67	26.36
5	840.67	39.63 QP	46.00	-6.37	1.50 H	70	12.49	27.13
6	902.89	39.96 QP	46.00	-6.04	2.00 H	25	11.84	28.12
ANTENNA POLARITY & TEST DISTANCE: VERTICAL AT 3 M								
NO.	FREQ. (MHz)	EMISSION LEVEL (dBuV/m)	LIMIT (dBuV/m)	MARGIN (dB)	ANTENNA HEIGHT (m)	TABLE ANGLE (Degree)	RAW VALUE (dBuV)	CORRECTION FACTOR (dB/m)
1	632.63	33.86 QP	46.00	-12.14	1.50 V	172	10.05	23.81
2	720.12	35.45 QP	46.00	-10.55	1.25 V	313	9.97	25.49
3	797.89	35.77 QP	46.00	-10.23	1.25 V	187	9.41	26.36
4	840.67	36.77 QP	46.00	-9.23	2.00 V	232	9.64	27.13
5	869.83	34.52 QP	46.00	-11.48	2.00 V	316	6.90	27.61
6	897.05	35.20 QP	46.00	-10.80	1.25 V	343	7.16	28.04

- REMARKS:**
1. Emission level (dBuV/m) = Raw Value (dBuV) + Correction Factor (dB/m).
 2. Correction Factor (dB/m) = Antenna Factor (dB/m) + Cable Factor (dB).
 3. The other emission levels were very low against the limit.
 4. Margin value = Emission level – Limit value.

4.2 CONDUCTED EMISSION MEASUREMENT

4.2.1 LIMITS OF CONDUCTED EMISSION MEASUREMENT

FREQUENCY OF EMISSION (MHz)	CONDUCTED LIMIT (dB μ V)	
	Quasi-peak	Average
0.15-0.5	66 to 56	56 to 46
0.5-5	56	46
5-30	60	50

- NOTE:**
1. The lower limit shall apply at the transition frequencies.
 2. The limit decreases in line with the logarithm of the frequency in the range of 0.15 to 0.50 MHz.
 3. All emanations from a class A/B digital device or system, including any network of conductors and apparatus connected thereto, shall not exceed the level of field strengths specified above.

4.2.2 TEST INSTRUMENTS

DESCRIPTION & MANUFACTURER	MODEL NO.	SERIAL NO.	DATE OF CALIBRATION	DUE DATE OF CALIBRATION
Test Receiver ROHDE & SCHWARZ	ESCS30	100291	Nov. 19, 2008	Nov. 18, 2009
RF signal cable Woken	5D-FB	Cable-HYC01-01	Jan. 04, 2008	Jan. 03, 2009
LISN ROHDE & SCHWARZ	ESH3-Z5	100312	Jun. 13, 2008	Jun. 12, 2009
LISN ROHDE & SCHWARZ	ESH2-Z5	100104	Dec. 04, 2008	Dec. 03, 2009
Software ADT	ADT_Cond_ V7.3.6	NA	NA	NA

- NOTE:**
1. The calibration interval of the above test instruments is 12 months and the calibrations are traceable to NML/ROC and NIST/USA.
 2. The test was performed in HwaYa Shielded Room 1.
 3. The VCCI Site Registration No. is C-2040.

4.2.3 TEST PROCEDURES

- a. The EUT was placed 0.4 meters from the conducting wall of the shielded room with EUT being connected to the power mains through a line impedance stabilization network (LISN). Other support units were connected to the power mains through another LISN. The two LISNs provide 50 ohm/ 50uH of coupling impedance for the measuring instrument.
- b. Both lines of the power mains connected to the EUT were checked for maximum conducted interference.
- c. The frequency range from 150kHz to 30MHz was searched. Emission levels under (Limit - 20dB) was not recorded.

4.2.4 DEVIATION FROM TEST STANDARD

No deviation

4.2.5 TEST SETUP

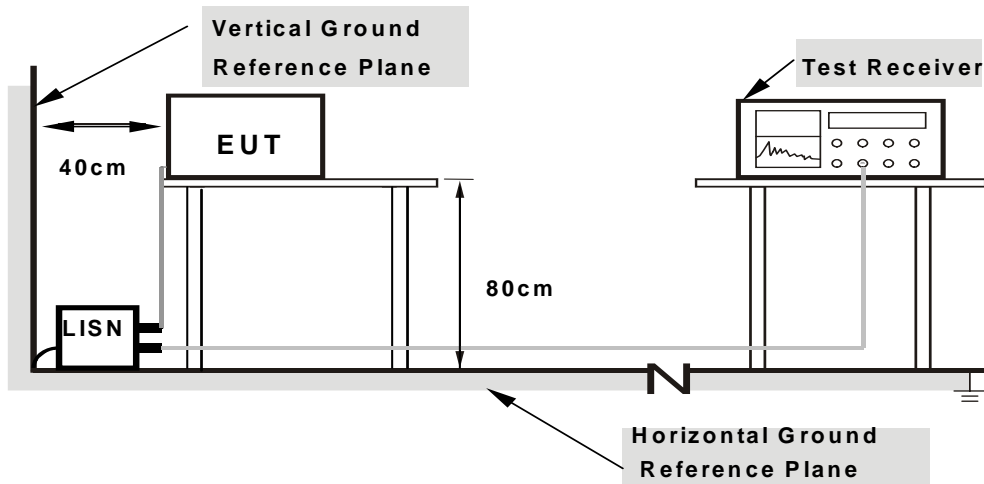

- Note:**
1. Support units were connected to second LISN.
 2. Both of LISNs (AMN) are 80 cm from EUT and at least 80 from other units and other metal planes

For the actual test configuration, please refer to the attached file (Test Setup Photo).

4.2.6 EUT OPERATING CONDITIONS

Same as 4.1.6

4.2.7 TEST RESULTS

Conducted Worst-Case Data: DRAFT 802.11n (20MHz) OFDM MODULATION: 2TX

EUT TEST CONDITION		MEASUREMENT DETAIL	
CHANNEL	Channel 6	PHASE	Line 1
MODULATION TYPE	BPSK	6dB BANDWIDTH	9 kHz
TRANSFER RATE	14.4Mbps	INPUT POWER	120Vac, 60 Hz
ENVIRONMENTAL CONDITIONS	23deg. C, 67%RH, 991hPa	TEST MODE	A
TESTED BY	Mark Liao		

No	Freq. [MHz]	Corr. Factor (dB)	Reading Value [dB (uV)]		Emission Level [dB (uV)]		Limit [dB (uV)]		Margin (dB)	
			Q.P.	AV.	Q.P.	AV.	Q.P.	AV.	Q.P.	AV.
1	0.162	0.20	49.30	-	49.50	-	65.38	55.38	-15.88	-
2	0.312	0.20	45.72	-	45.92	-	59.93	49.93	-14.01	-
3	0.463	0.20	36.88	-	37.08	-	56.65	46.65	-19.57	-
4	0.628	0.20	41.43	-	41.63	-	56.00	46.00	-14.37	-
5	0.876	0.20	38.00	-	38.20	-	56.00	46.00	-17.80	-
6	18.160	0.93	40.44	-	41.37	-	60.00	50.00	-18.63	-

- REMARKS:**
1. Q.P. and AV. are abbreviations of quasi-peak and average individually.
 2. "-": The Quasi-peak reading value also meets average limit and measurement with the average detector is unnecessary.
 3. The emission levels of other frequencies were very low against the limit.
 4. Margin value = Emission level - Limit value
 5. Correction factor = Insertion loss + Cable loss
 6. Emission Level = Correction Factor + Reading Value.

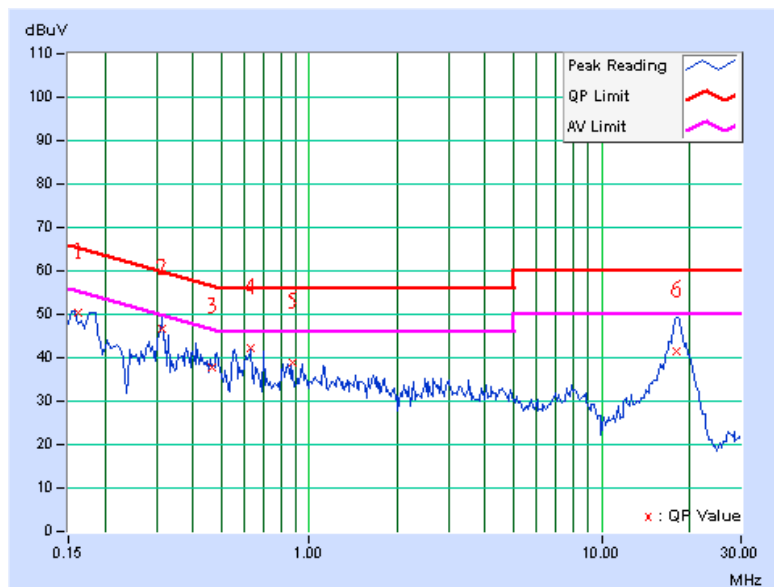



A D T

EUT TEST CONDITION		MEASUREMENT DETAIL	
CHANNEL	Channel 6	PHASE	Line 2
MODULATION TYPE	BPSK	6dB BANDWIDTH	9 kHz
TRANSFER RATE	14.4Mbps	INPUT POWER	120Vac, 60 Hz
ENVIRONMENTAL CONDITIONS	23deg. C, 67%RH, 991hPa	TEST MODE	A
TESTED BY	Mark Liao		

No	Freq. [MHz]	Corr. Factor (dB)	Reading Value [dB (uV)]		Emission Level [dB (uV)]		Limit [dB (uV)]		Margin (dB)	
			Q.P.	AV.	Q.P.	AV.	Q.P.	AV.	Q.P.	AV.
			1	0.185	0.20	47.02	-	47.22	-	64.26
2	0.314	0.20	45.34	-	45.54	-	59.86	49.86	-14.32	-
3	0.412	0.20	37.95	-	38.15	-	57.61	47.61	-19.46	-
4	0.628	0.20	39.94	-	40.14	-	56.00	46.00	-15.86	-
5	1.121	0.20	35.21	-	35.41	-	56.00	46.00	-20.59	-
6	18.258	0.51	39.19	-	39.70	-	60.00	50.00	-20.30	-

- REMARKS:**
1. Q.P. and AV. are abbreviations of quasi-peak and average individually.
 2. "-": The Quasi-peak reading value also meets average limit and measurement with the average detector is unnecessary.
 3. The emission levels of other frequencies were very low against the limit.
 4. Margin value = Emission level - Limit value
 5. Correction factor = Insertion loss + Cable loss
 6. Emission Level = Correction Factor + Reading Value.

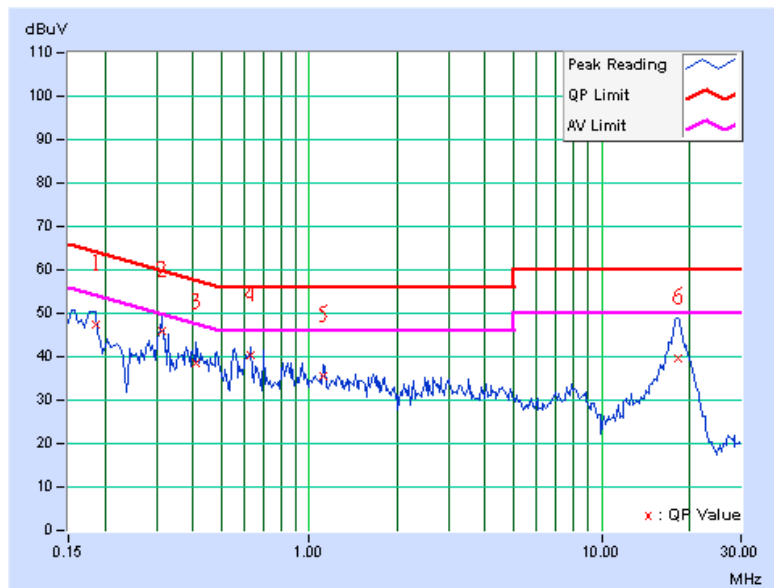



A D T

Conducted Worst-Case Data: DRAFT 802.11n (20MHz) OFDM MODULATION: 2TX

EUT TEST CONDITION		MEASUREMENT DETAIL	
CHANNEL	Channel 6	PHASE	Line 1
MODULATION TYPE	BPSK	6dB BANDWIDTH	9 kHz
TRANSFER RATE	14.4Mbps	INPUT POWER	120Vac, 60 Hz
ENVIRONMENTAL CONDITIONS	23deg. C, 67%RH, 991hPa	TEST MODE	B
TESTED BY	Mark Liao		

No	Freq. [MHz]	Corr. Factor (dB)	Reading Value [dB (uV)]		Emission Level [dB (uV)]		Limit [dB (uV)]		Margin (dB)	
			Q.P.	AV.	Q.P.	AV.	Q.P.	AV.	Q.P.	AV.
			1	0.162	0.20	49.24	-	49.44	-	65.34
2	0.313	0.20	45.88	-	46.08	-	59.90	49.90	-13.82	-
3	0.465	0.20	35.97	-	36.17	-	56.61	46.61	-20.44	-
4	0.625	0.20	41.06	-	41.26	-	56.00	46.00	-14.74	-
5	0.879	0.20	37.59	-	37.79	-	56.00	46.00	-18.21	-
6	18.150	0.93	40.39	-	41.32	-	60.00	50.00	-18.68	-

- REMARKS:**
1. Q.P. and AV. are abbreviations of quasi-peak and average individually.
 2. "-": The Quasi-peak reading value also meets average limit and measurement with the average detector is unnecessary.
 3. The emission levels of other frequencies were very low against the limit.
 4. Margin value = Emission level - Limit value
 5. Correction factor = Insertion loss + Cable loss
 6. Emission Level = Correction Factor + Reading Value.

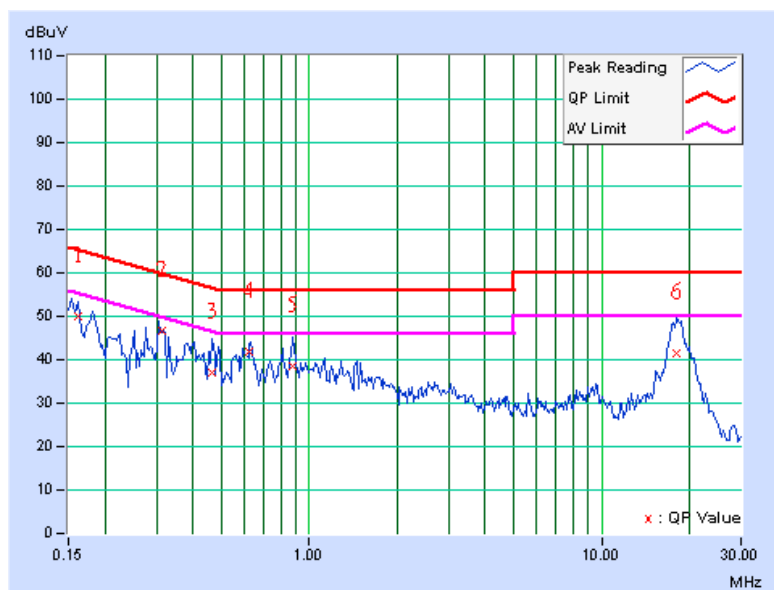



A D T

EUT TEST CONDITION		MEASUREMENT DETAIL	
CHANNEL	Channel 6	PHASE	Line 2
MODULATION TYPE	BPSK	6dB BANDWIDTH	9 kHz
TRANSFER RATE	14.4Mbps	INPUT POWER	120Vac, 60 Hz
ENVIRONMENTAL CONDITIONS	23deg. C, 67%RH, 991hPa	TEST MODE	B
TESTED BY	Mark Liao		

No	Freq.	Corr.	Reading Value		Emission Level		Limit		Margin	
	[MHz]	Factor	[dB (uV)]		[dB (uV)]		[dB (uV)]		(dB)	
		(dB)	Q.P.	AV.	Q.P.	AV.	Q.P.	AV.	Q.P.	AV.
1	0.185	0.20	47.24	-	47.44	-	64.26	54.26	-16.82	-
2	0.315	0.20	45.57	-	45.77	-	59.83	49.83	-14.06	-
3	0.412	0.20	37.84	-	38.04	-	57.60	47.60	-19.56	-
4	0.629	0.20	39.79	-	39.99	-	56.00	46.00	-16.01	-
5	1.124	0.20	34.48	-	34.68	-	56.00	46.00	-21.32	-
6	18.247	0.51	39.25	-	39.76	-	60.00	50.00	-20.24	-

- REMARKS:**
1. Q.P. and AV. are abbreviations of quasi-peak and average individually.
 2. "-": The Quasi-peak reading value also meets average limit and measurement with the average detector is unnecessary.
 3. The emission levels of other frequencies were very low against the limit.
 4. Margin value = Emission level - Limit value
 5. Correction factor = Insertion loss + Cable loss
 6. Emission Level = Correction Factor + Reading Value.

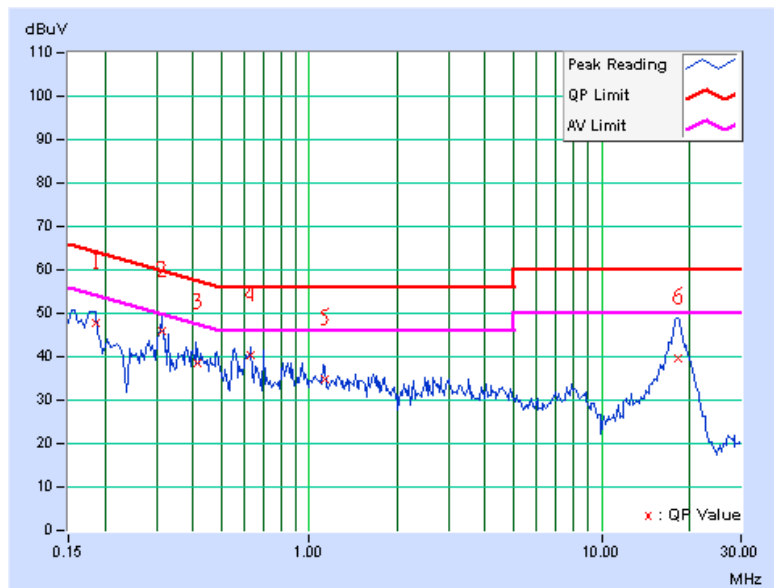

4.3 6dB BANDWIDTH MEASUREMENT

4.3.1 LIMITS OF 6dB BANDWIDTH MEASUREMENT

The minimum of 6dB Bandwidth Measurement is 0.5 MHz.

4.3.2 TEST INSTRUMENTS

DESCRIPTION & MANUFACTURER	MODEL NO.	SERIAL NO.	DATE OF CALIBRATION	DUE DATE OF CALIBRATION
SPECTRUM ANALYZER	FSP 40	100041	Apr. 22, 2008	Apr. 21, 2009

NOTE: The calibration interval of the above test instruments is 12 months and the calibrations are traceable to NML/ROC and NIST/USA.

4.3.3 TEST PROCEDURE

The transmitter output was connected to the spectrum analyzer through an attenuator. The bandwidth of the fundamental frequency was measured by spectrum analyzer with 100kHz RBW and 100kHz VBW. The 6dB bandwidth is defined as the total spectrum the power of which is higher than peak power minus 6dB.

4.3.4 DEVIATION FROM TEST STANDARD

No deviation

4.3.5 TEST SETUP

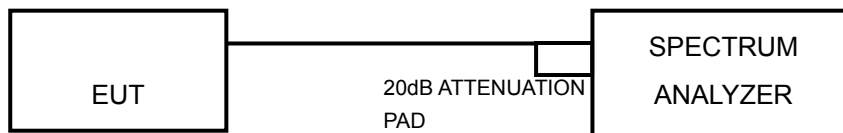

4.3.6 EUT OPERATING CONDITIONS

The software provided by client to enable the EUT under transmission condition continuously at lowest, middle and highest channel frequencies individually.



A D T

4.3.7 TEST RESULTS

802.11b DSSS MODULATION: 1TX

MODULATION TYPE	DBPSK	TRANSFER RATE	1.0Mbps
INPUT POWER	120Vac, 60 Hz	ENVIRONMENTAL CONDITIONS	22deg.C, 63%RH, 991hPa
TESTED BY	Mark Liao		

CHANNEL	CHANNEL FREQUENCY (MHz)	6dB BANDWIDTH (MHz)	MINIMUM LIMIT (MHz)	PASS / FAIL
1	2412	12.18	0.5	PASS
6	2437	12.21	0.5	PASS
11	2462	12.19	0.5	PASS

CH 1

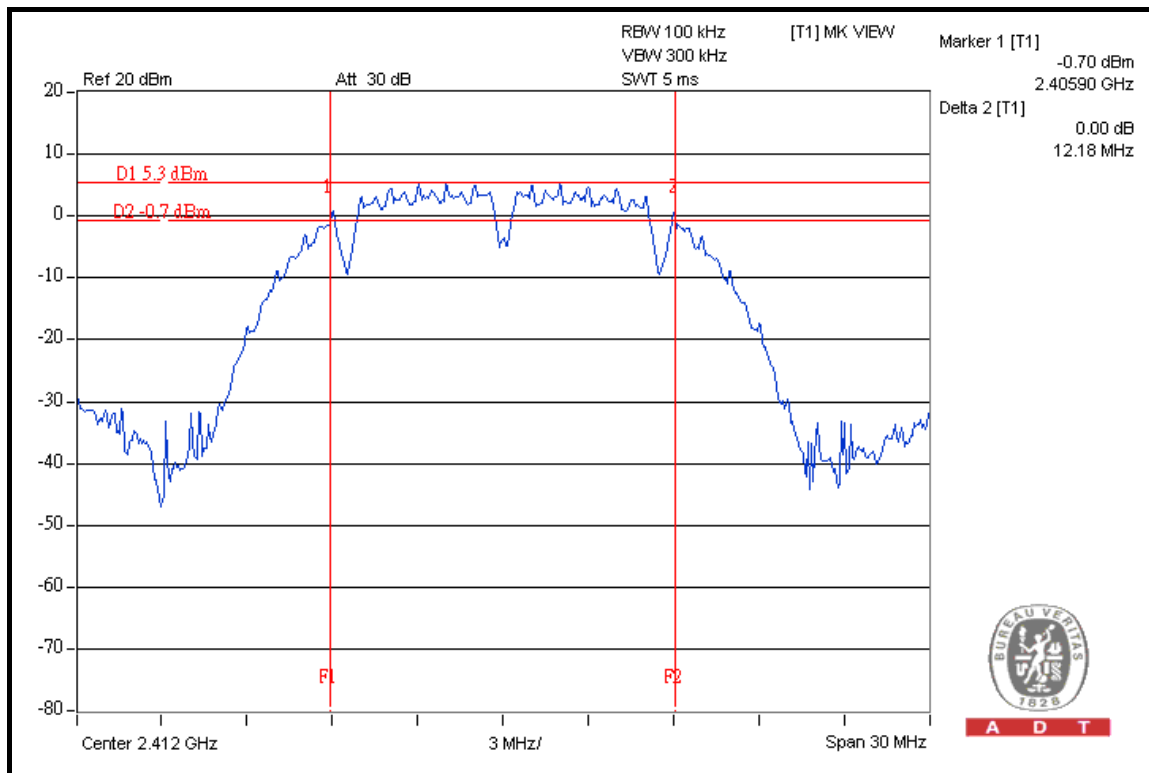



A D T

CH 6

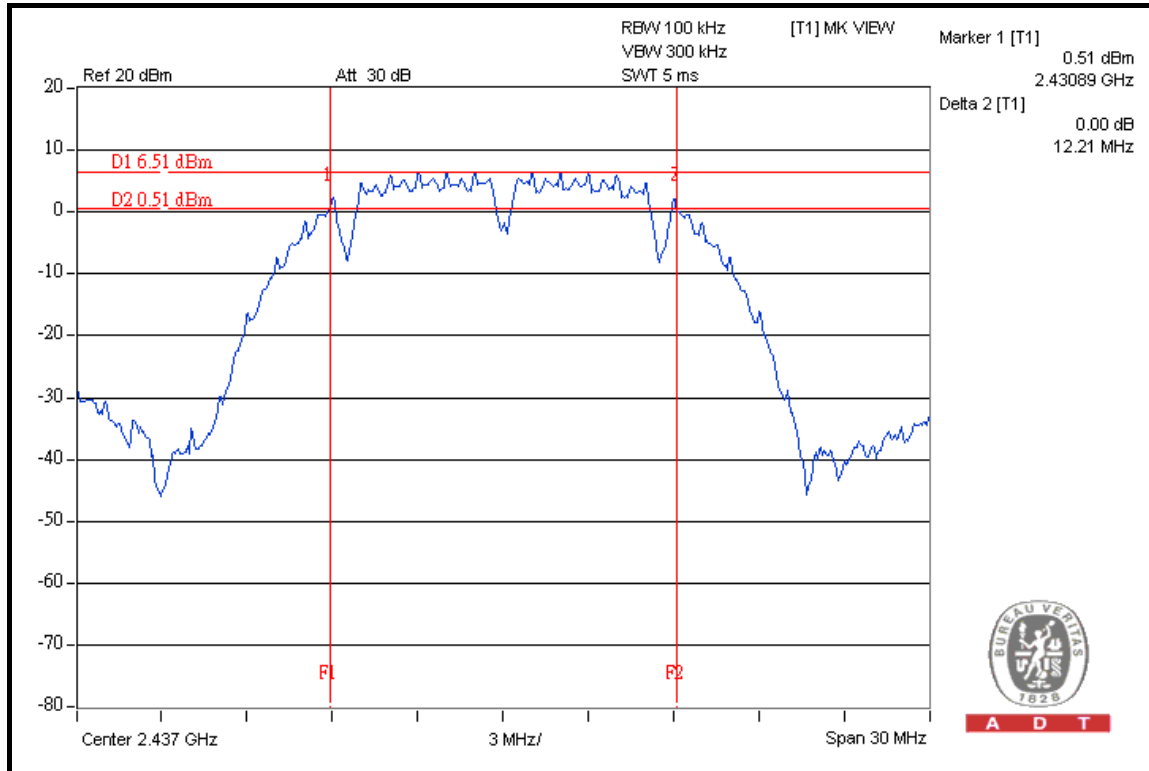

CH 11

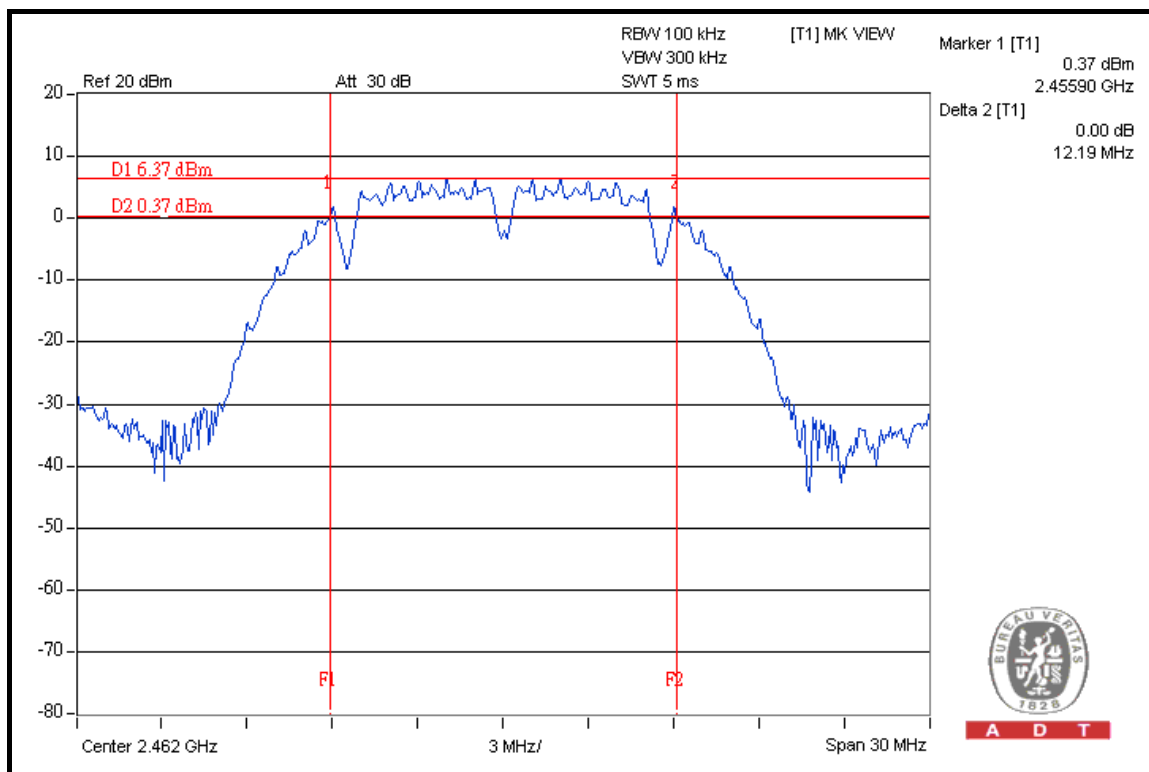



A D T

802.11g OFDM MODULATION: 1TX

MODULATION TYPE	BPSK	TRANSFER RATE	6.0Mbps
INPUT POWER	120Vac, 60 Hz	ENVIRONMENTAL CONDITIONS	22deg.C, 63%RH, 991hPa
TESTED BY	Mark Liao		

CHANNEL	CHANNEL FREQUENCY (MHz)	6dB BANDWIDTH (MHz)	MINIMUM LIMIT (MHz)	PASS / FAIL
1	2412	16.60	0.5	PASS
6	2437	16.63	0.5	PASS
11	2462	16.62	0.5	PASS

CH 1

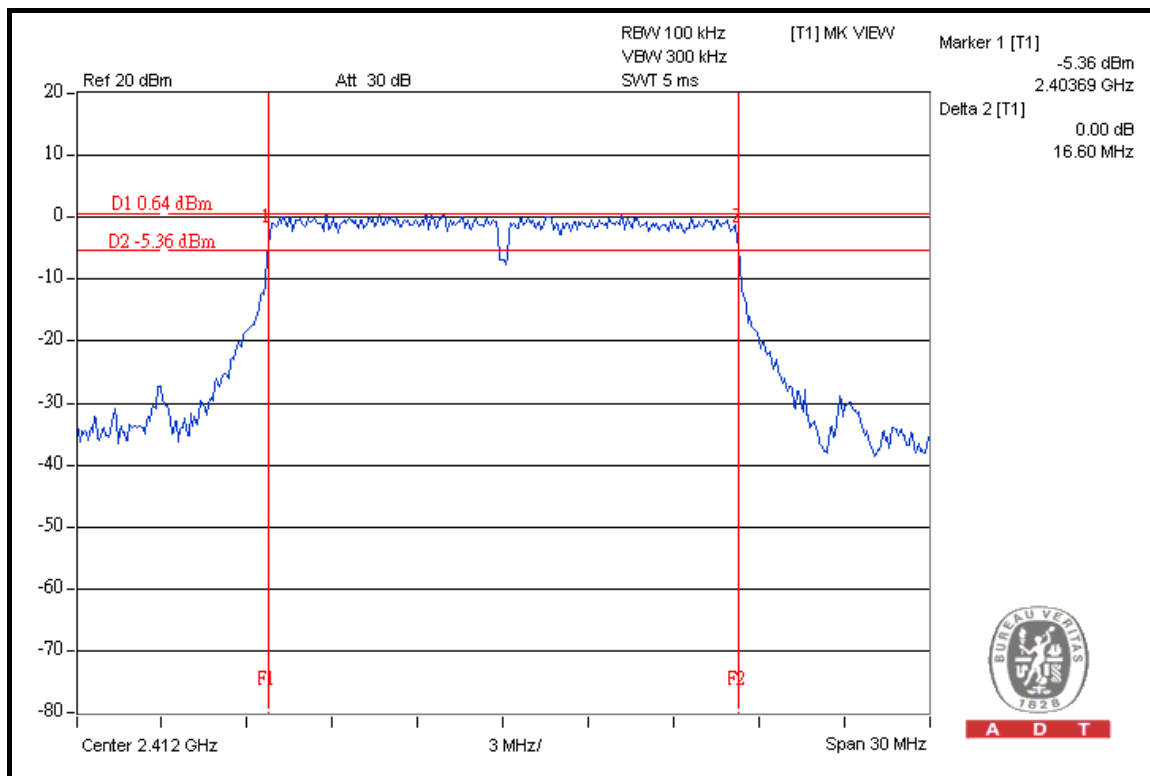



A D T

CH 6

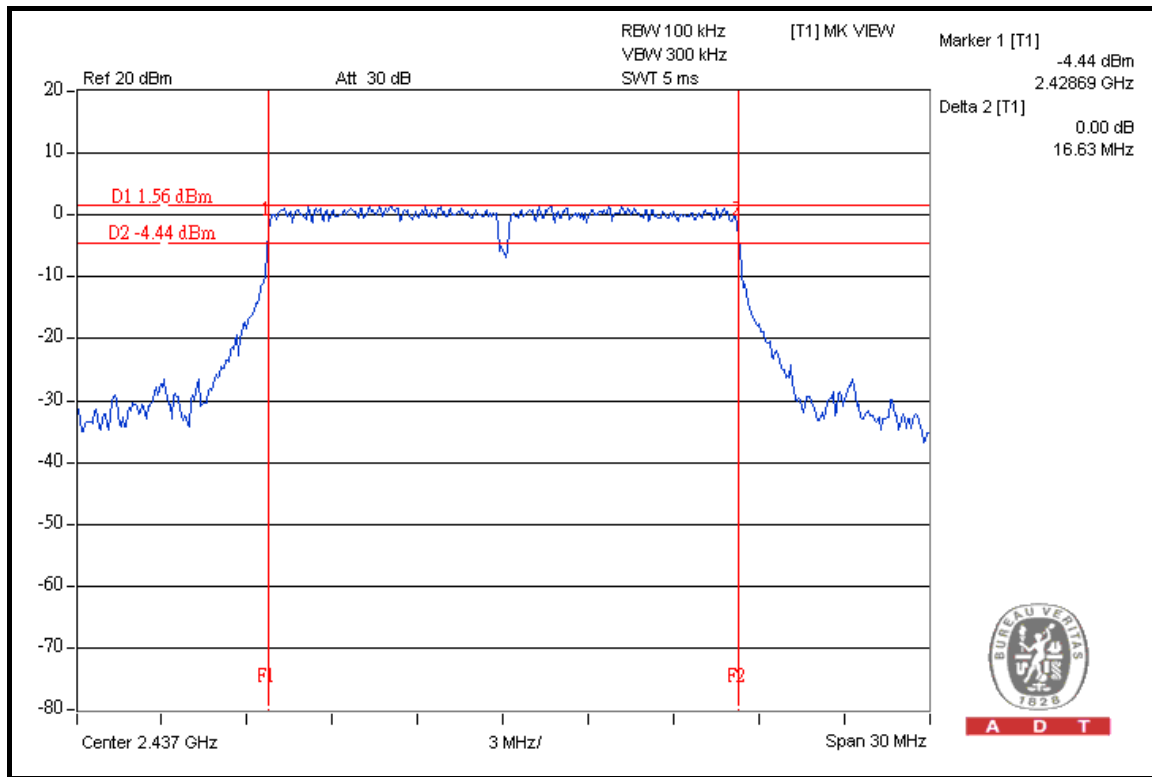

CH 11

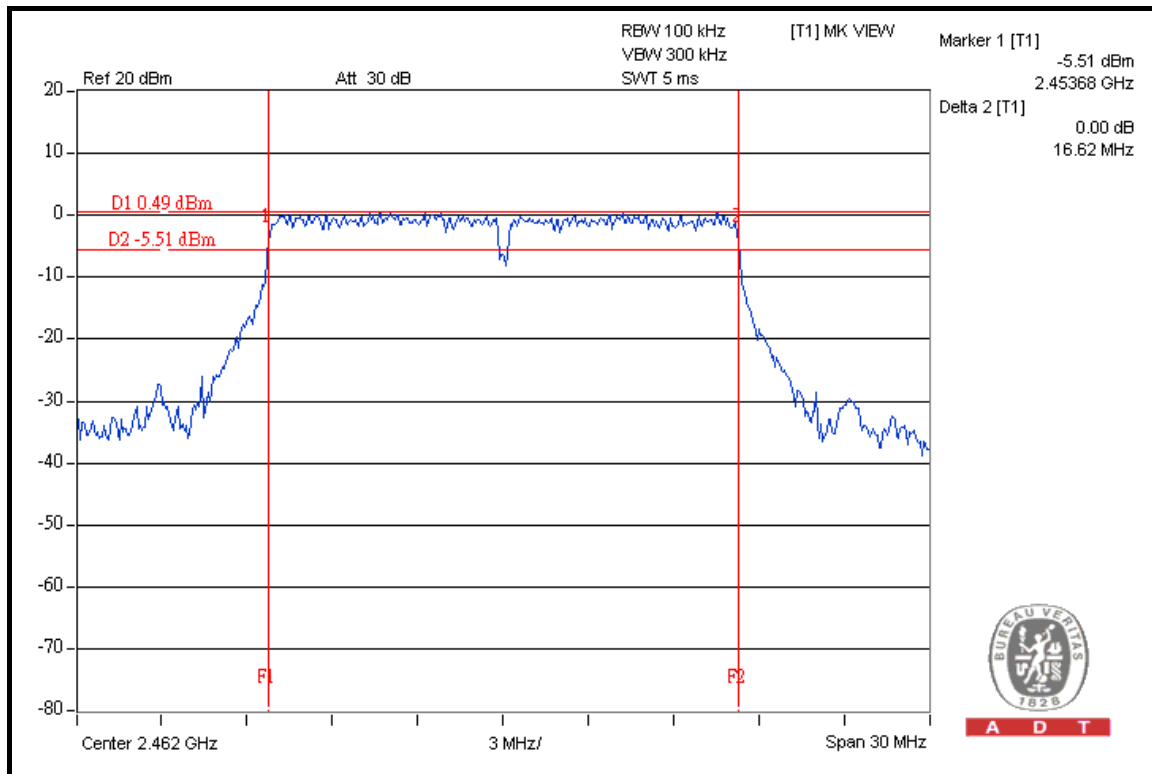



A D T

DRAFT 802.11n (20MHz) OFDM MODULATION: 1TX

MODULATION TYPE	BPSK	TRANSFER RATE	7.2Mbps
INPUT POWER	120Vac, 60 Hz	ENVIRONMENTAL CONDITIONS	22deg.C, 63%RH, 991hPa
TESTED BY	Mark Liao		

CHANNEL	CHANNEL FREQUENCY (MHz)	6dB BANDWIDTH (MHz)	MINIMUM LIMIT (MHz)	PASS / FAIL
1	2412	17.72	0.5	PASS
6	2437	17.73	0.5	PASS
11	2462	17.72	0.5	PASS

CH 1

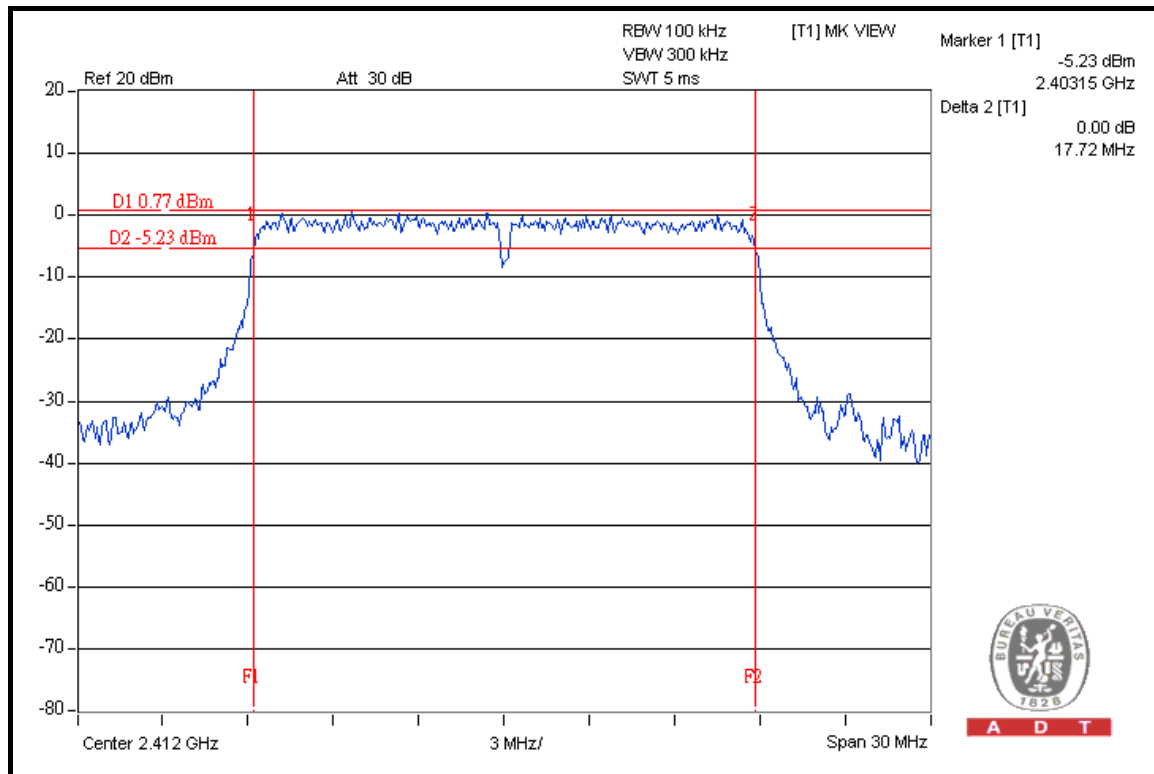



A D T

CH 6

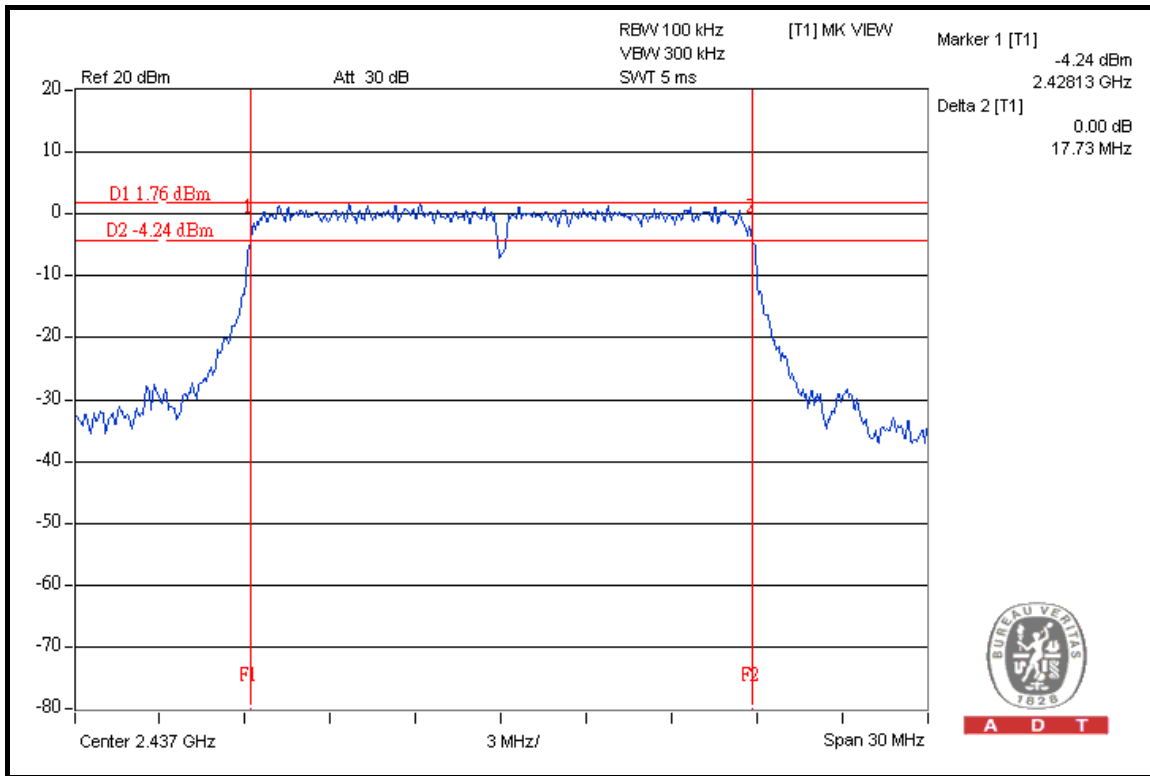

CH 11

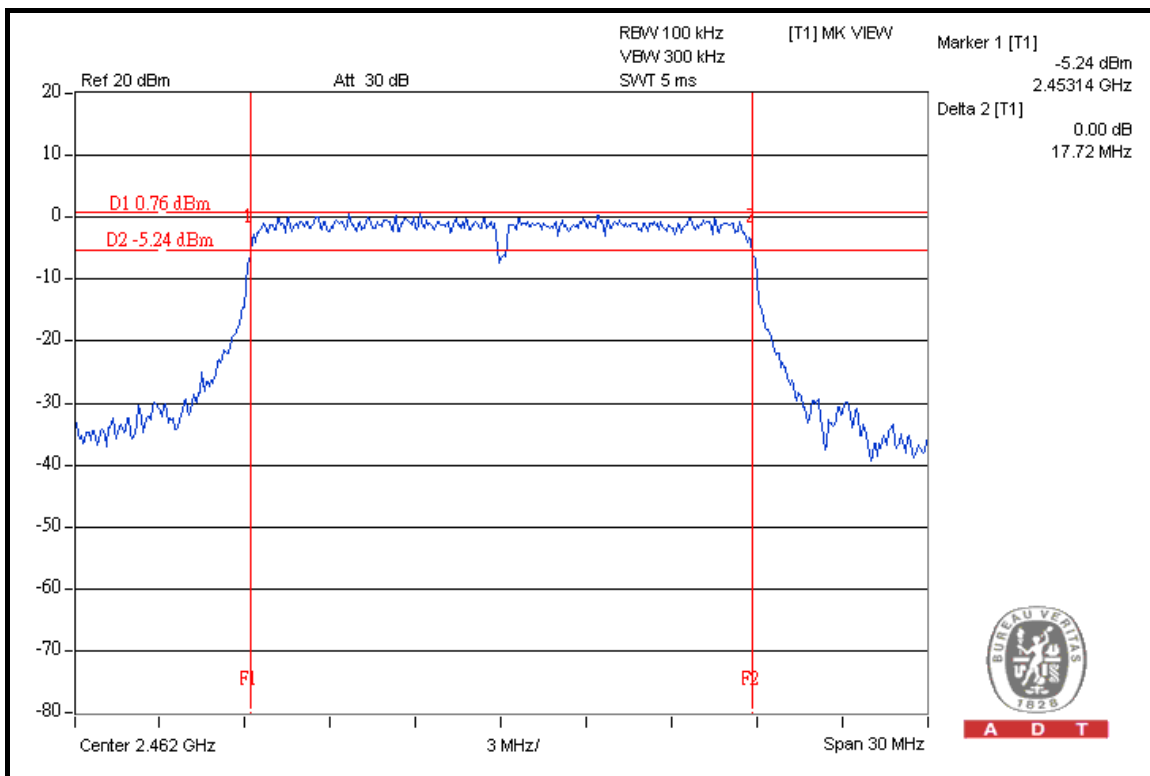



A D T

DRAFT 802.11n (20MHz) OFDM MODULATION: 2TX

MODULATION TYPE	BPSK	TRANSFER RATE	14.4Mbps
INPUT POWER	120Vac, 60 Hz	ENVIRONMENTAL CONDITIONS	22deg.C, 63%RH, 991hPa
TESTED BY	Mark Liao		

CHANNEL	CHANNEL FREQUENCY (MHz)	6dB BANDWIDTH (MHz)		MINIMUM LIMIT (MHz)	PASS / FAIL
		CHAIN 0	CHAIN 1		
1	2412	17.77	17.76	0.5	PASS
6	2437	17.75	17.71	0.5	PASS
11	2462	17.74	17.71	0.5	PASS



A D T

FOR CHAIN 0: CH 1

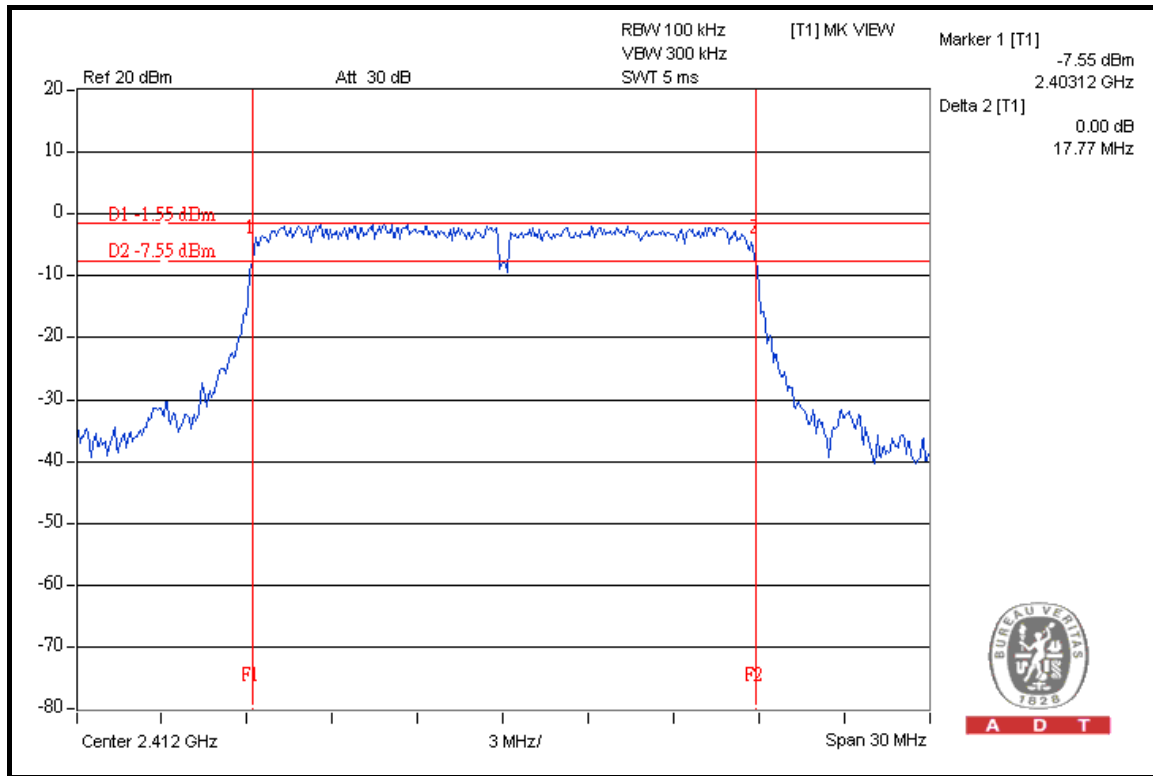

CH 6

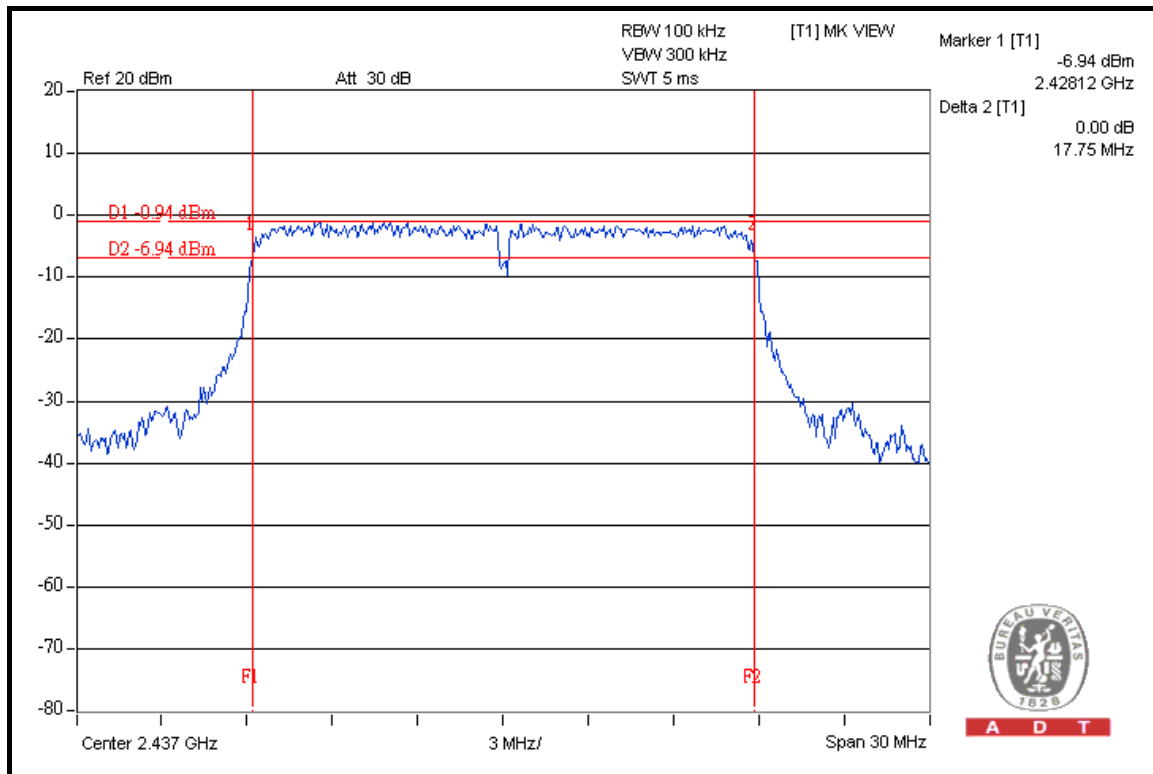



A D T

CH 11

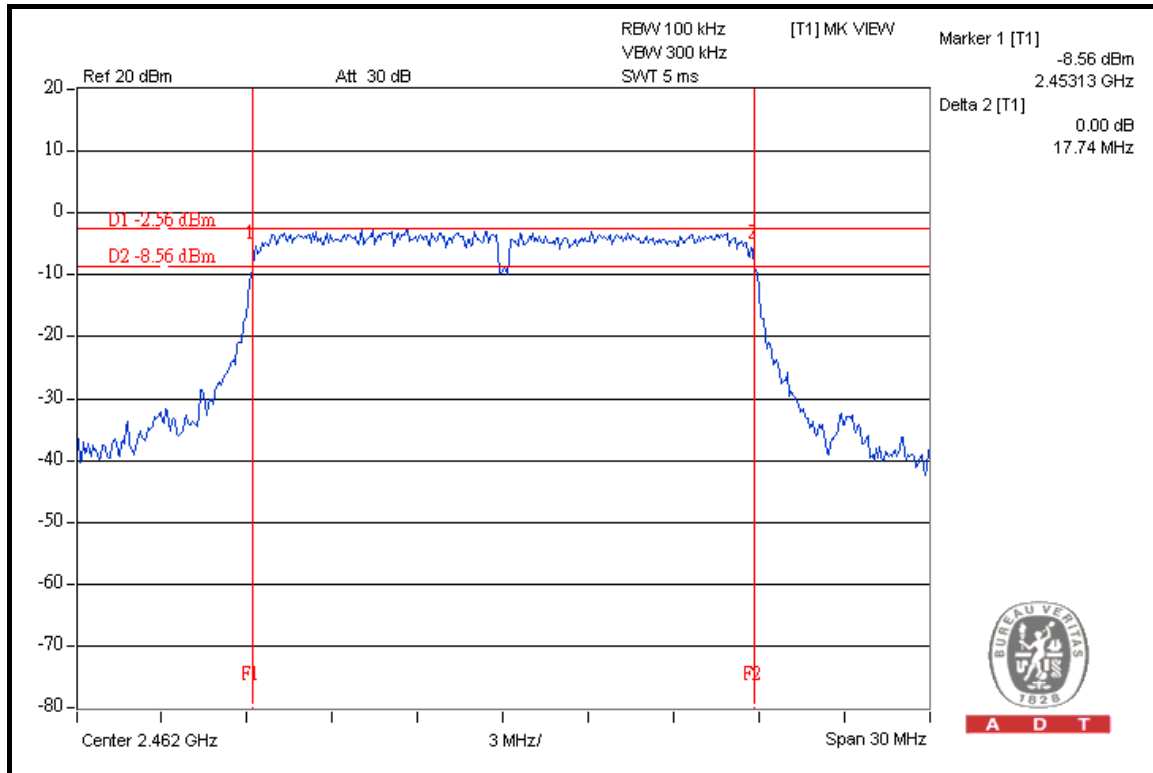

FOR CHAIN 1: CH 1

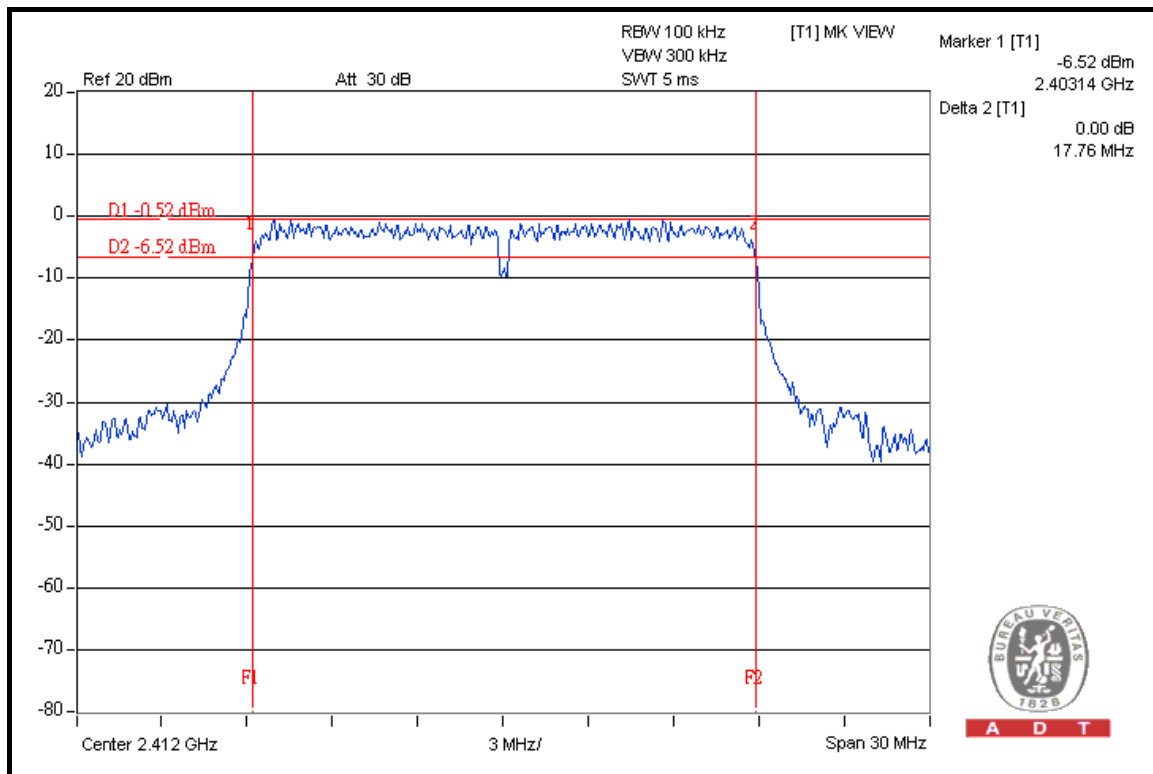



A D T

CH 6

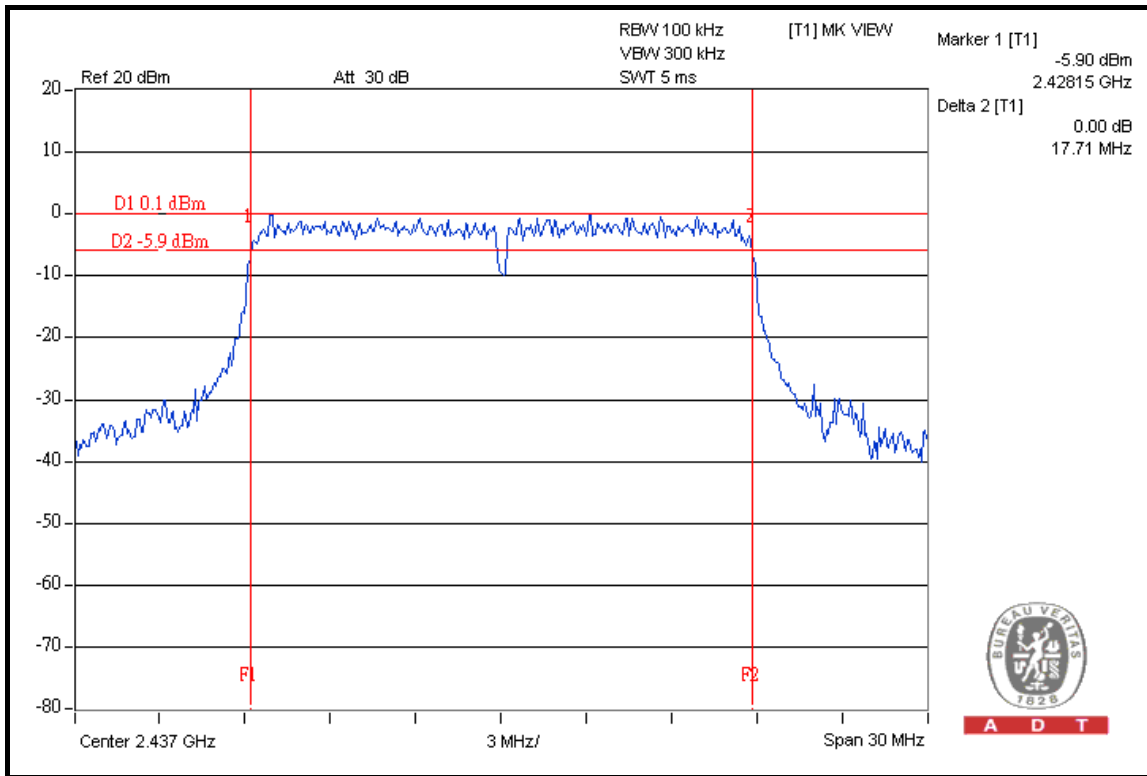

CH 11

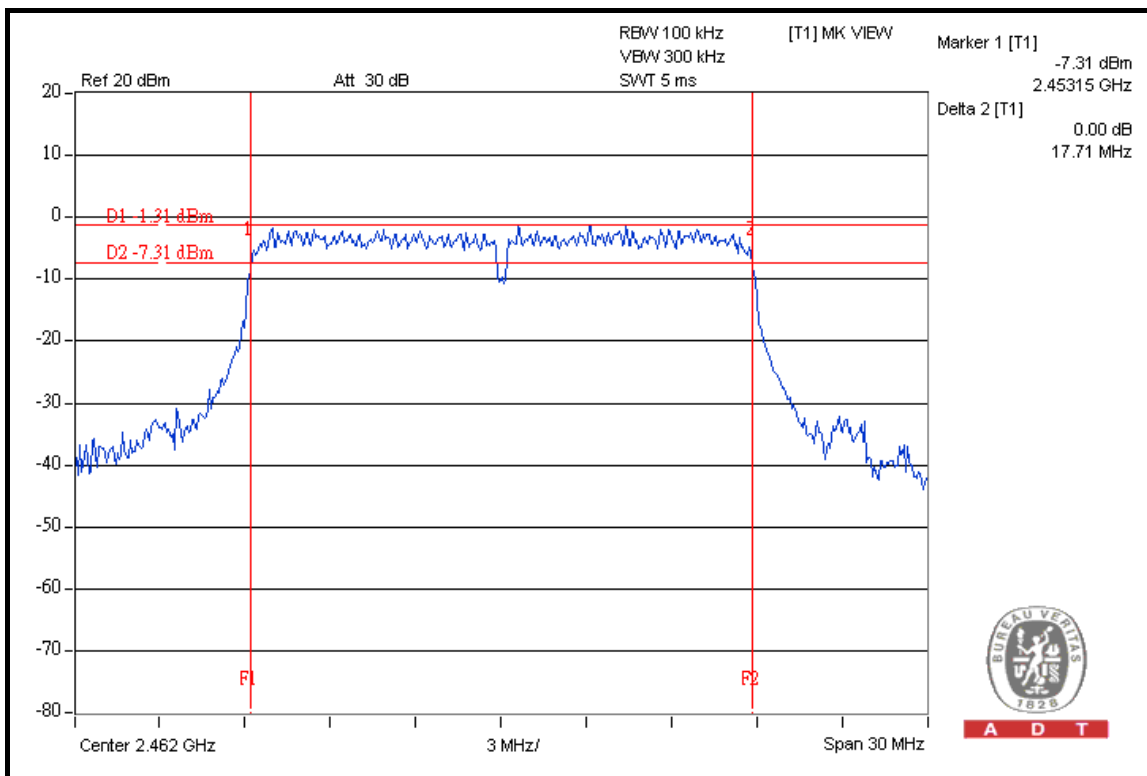



A D T

DRAFT 802.11n (40MHz) OFDM MODULATION: 1TX

MODULATION TYPE	BPSK	TRANSFER RATE	15.0Mbps
INPUT POWER	120Vac, 60 Hz	ENVIRONMENTAL CONDITIONS	22deg.C, 63%RH, 991hPa
TESTED BY	Mark Liao		

CHANNEL	CHANNEL FREQUENCY (MHz)	6dB BANDWIDTH (MHz)	MINIMUM LIMIT (MHz)	PASS / FAIL
1	2422	36.49	0.5	PASS
4	2437	36.54	0.5	PASS
7	2452	36.54	0.5	PASS

CH 1

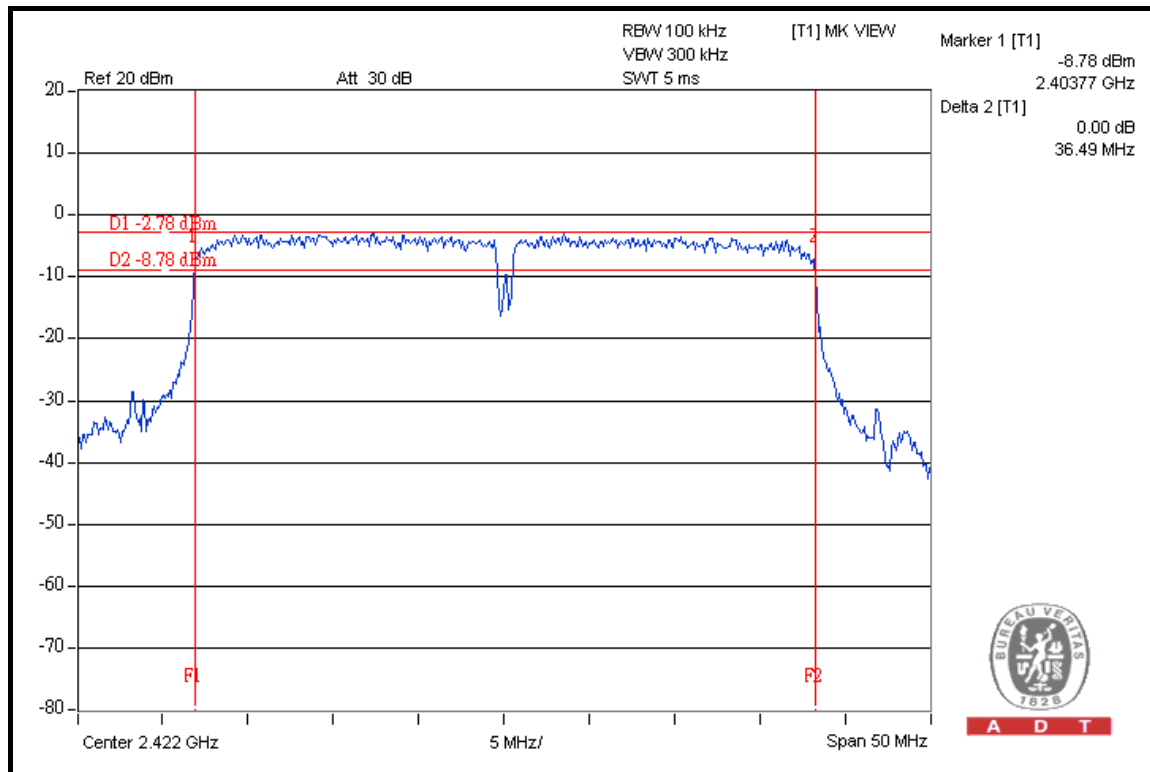



A D T

CH 4

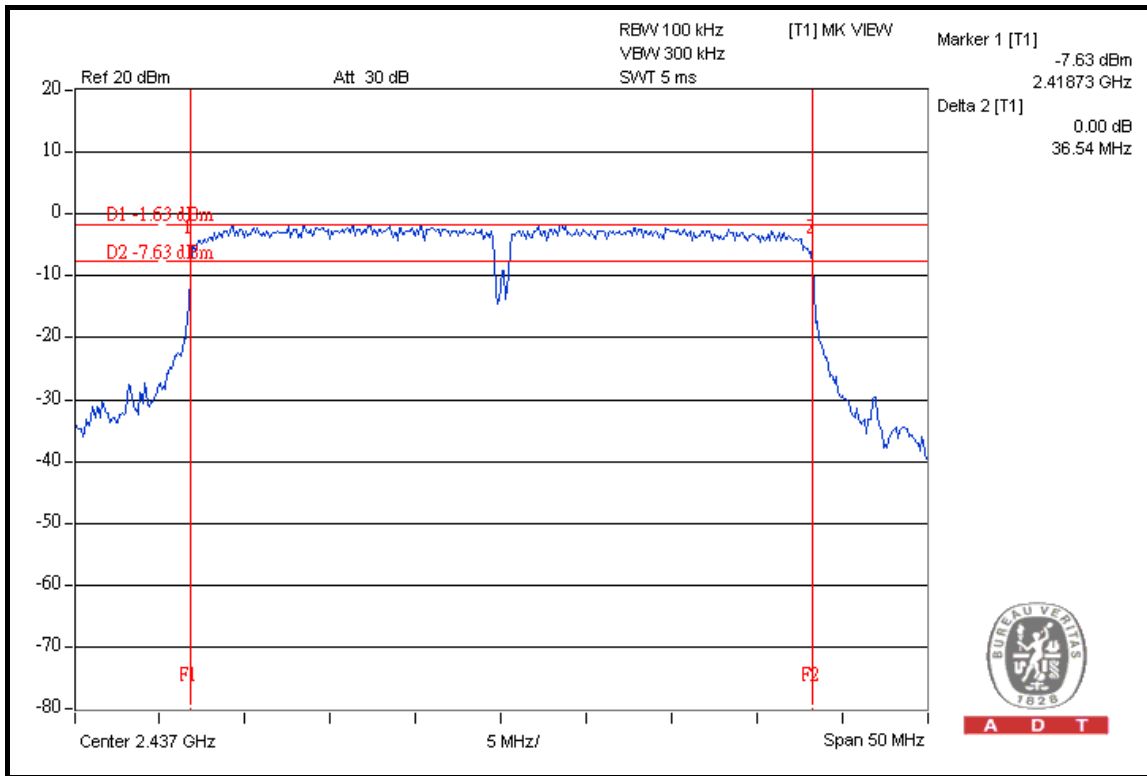

A D T

CH 7

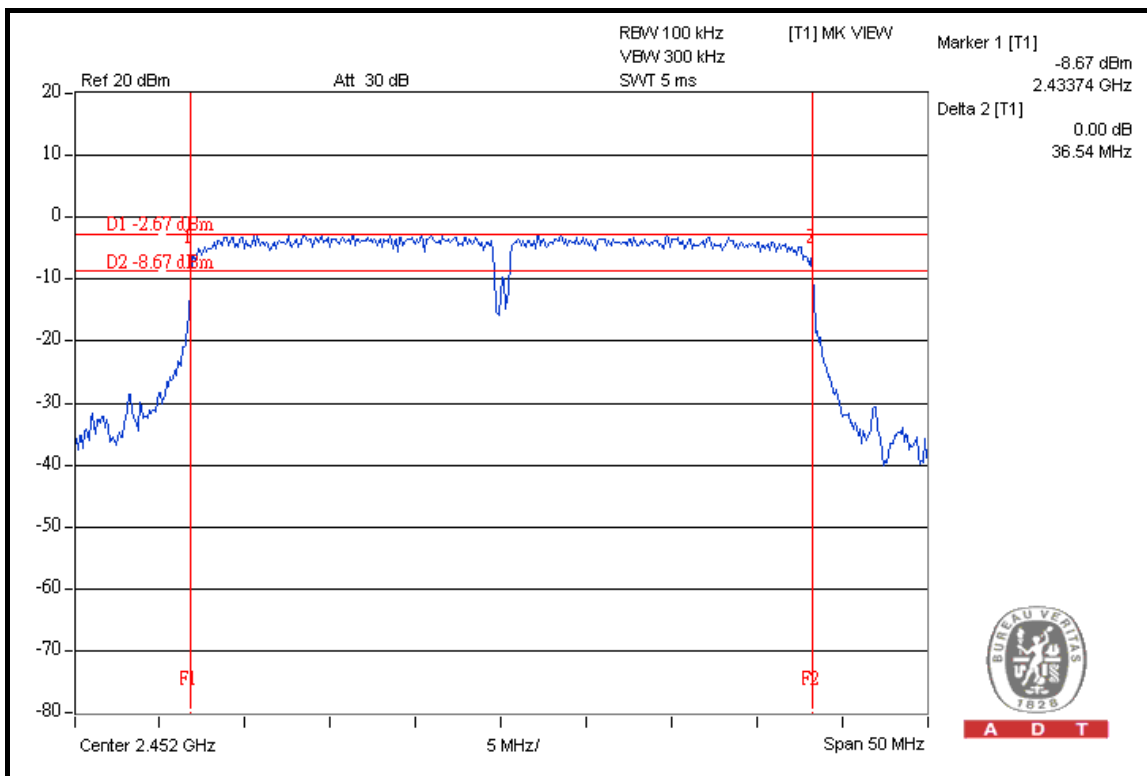

A D T



A D T

DRAFT 802.11n (40MHz) OFDM MODULATION: 2TX

MODULATION TYPE	BPSK	TRANSFER RATE	30.0Mbps
INPUT POWER	120Vac, 60 Hz	ENVIRONMENTAL CONDITIONS	22deg.C, 63%RH, 991hPa
TESTED BY	Mark Liao		

CHANNEL	CHANNEL FREQUENCY (MHz)	6dB BANDWIDTH (MHz)		MINIMUM LIMIT (MHz)	PASS / FAIL
		CHAIN 0	CHAIN 1		
1	2422	36.48	36.46	0.5	PASS
4	2437	36.49	36.46	0.5	PASS
7	2452	36.47	36.51	0.5	PASS



A D T

FOR CHAIN 0: CH 1

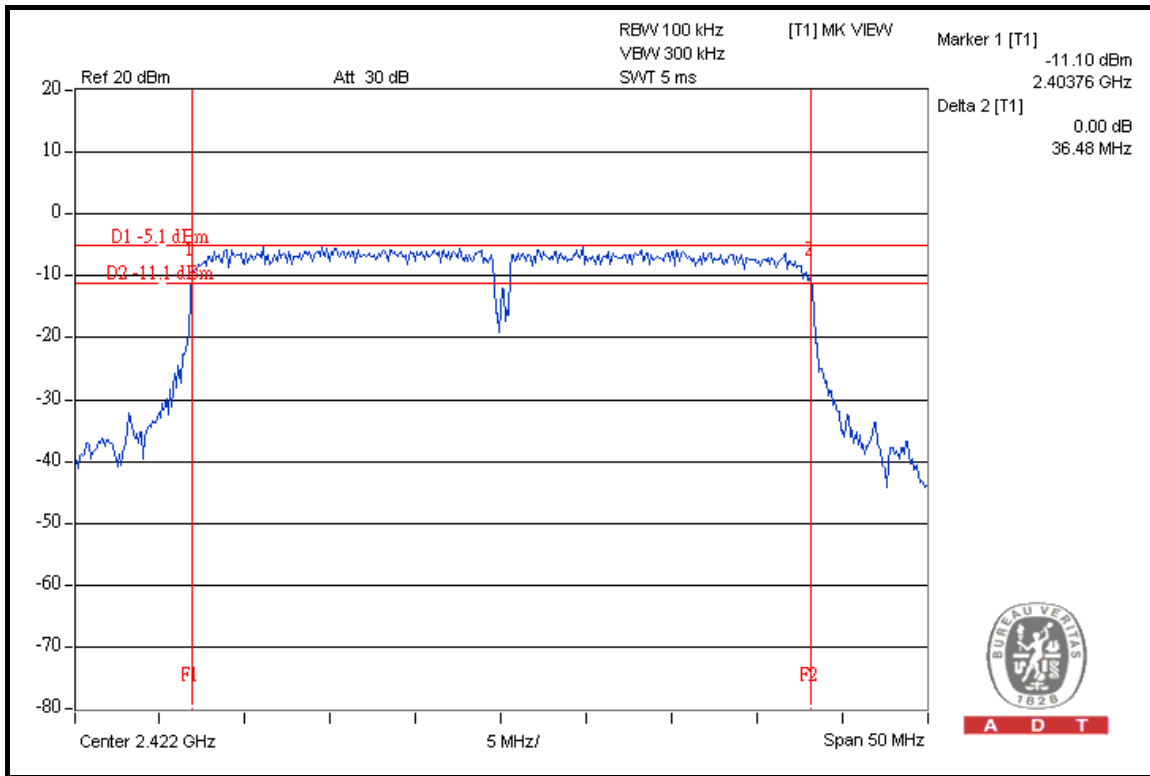

CH 4

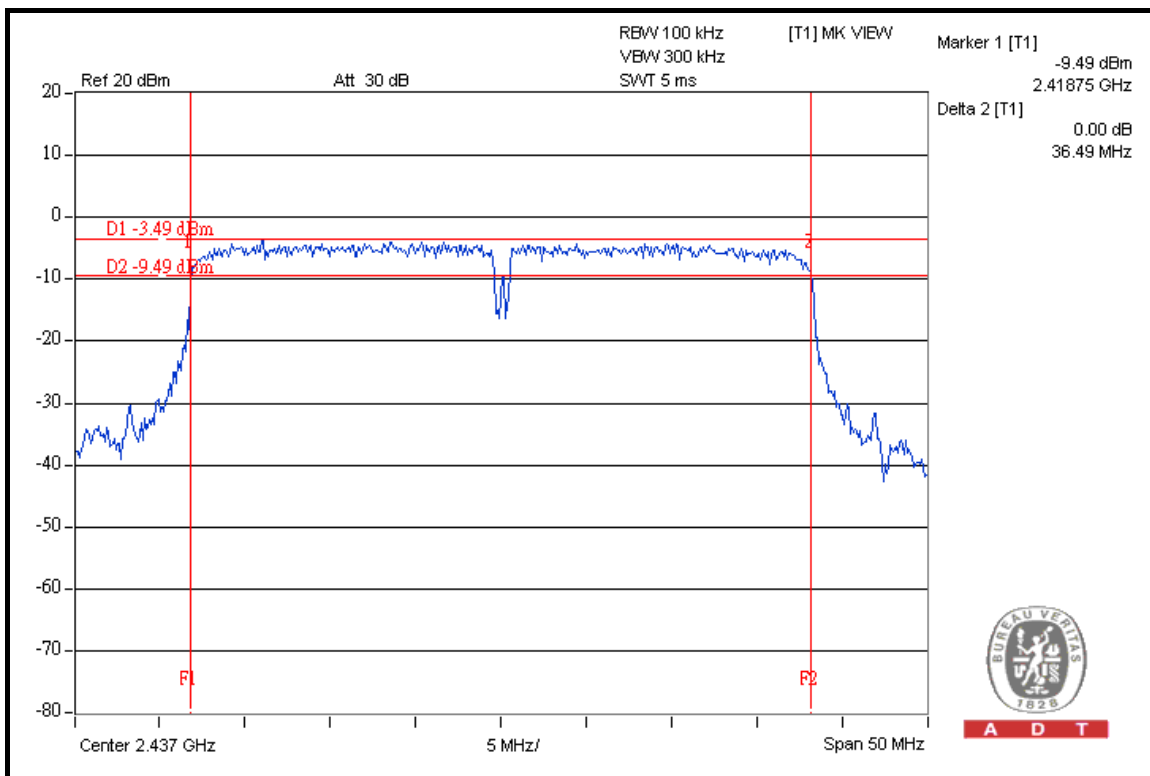



A D T

CH 7

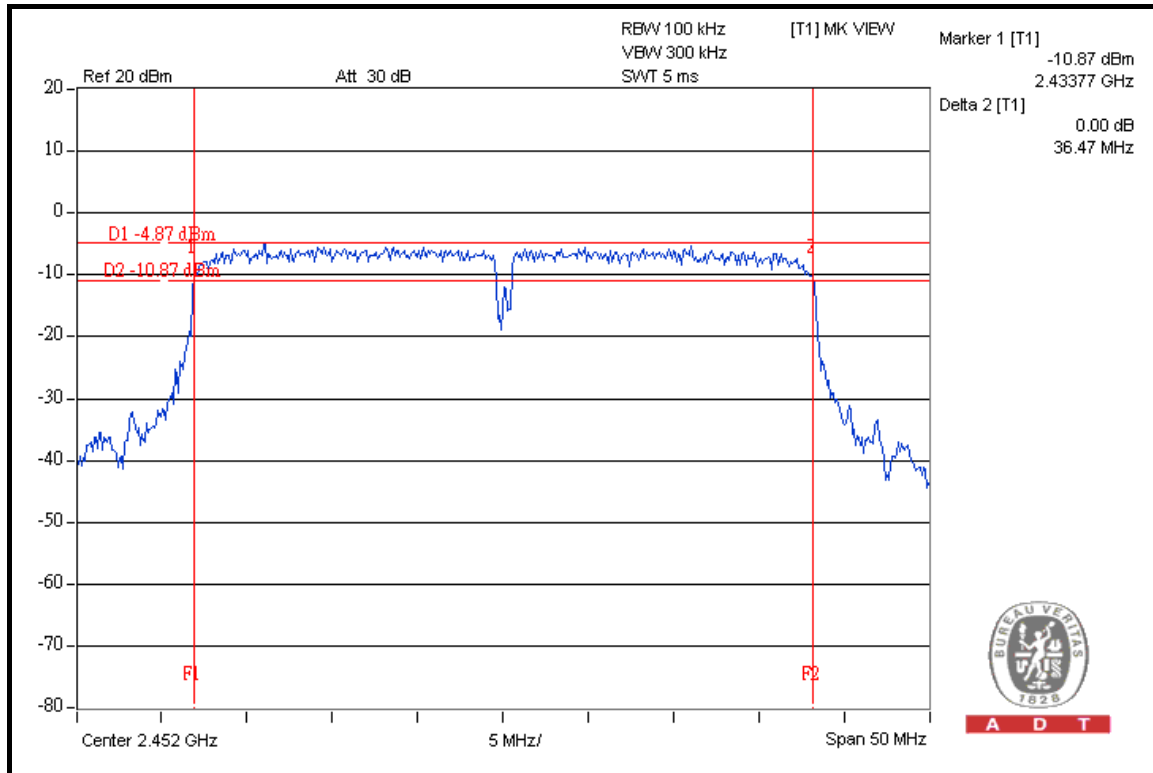

A D T

FOR CHAIN 1: CH 1

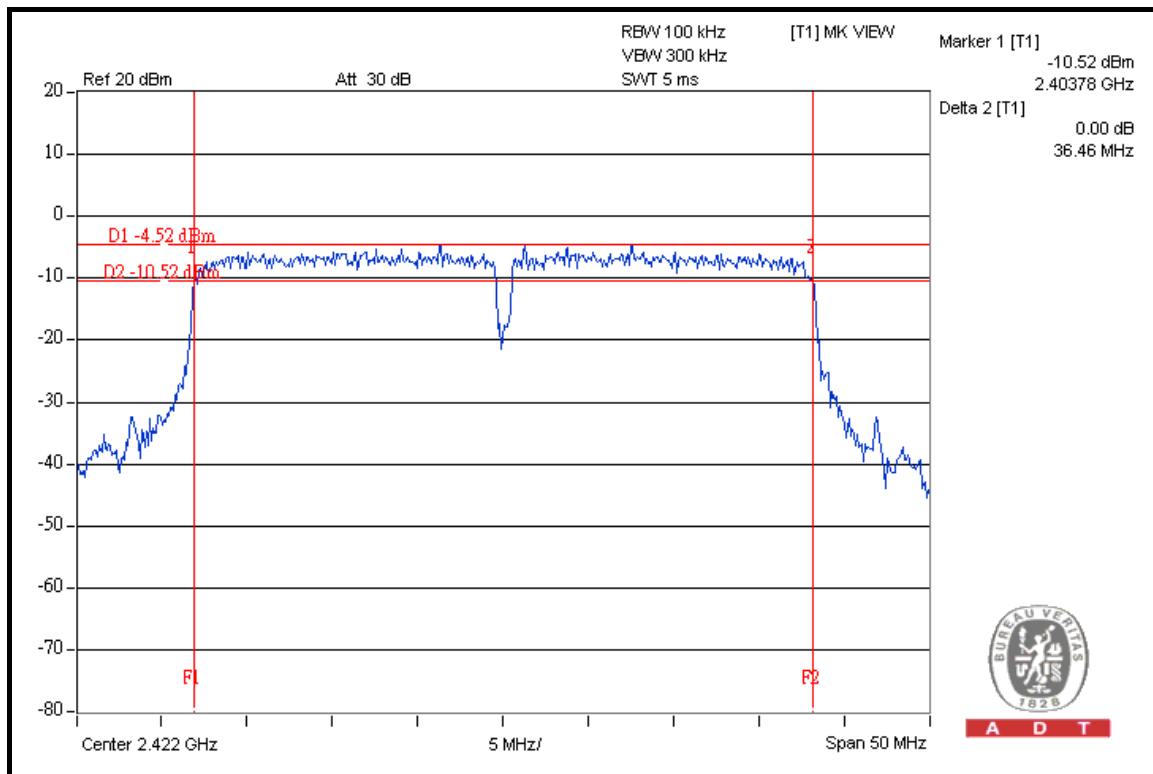

A D T



A D T

CH 4

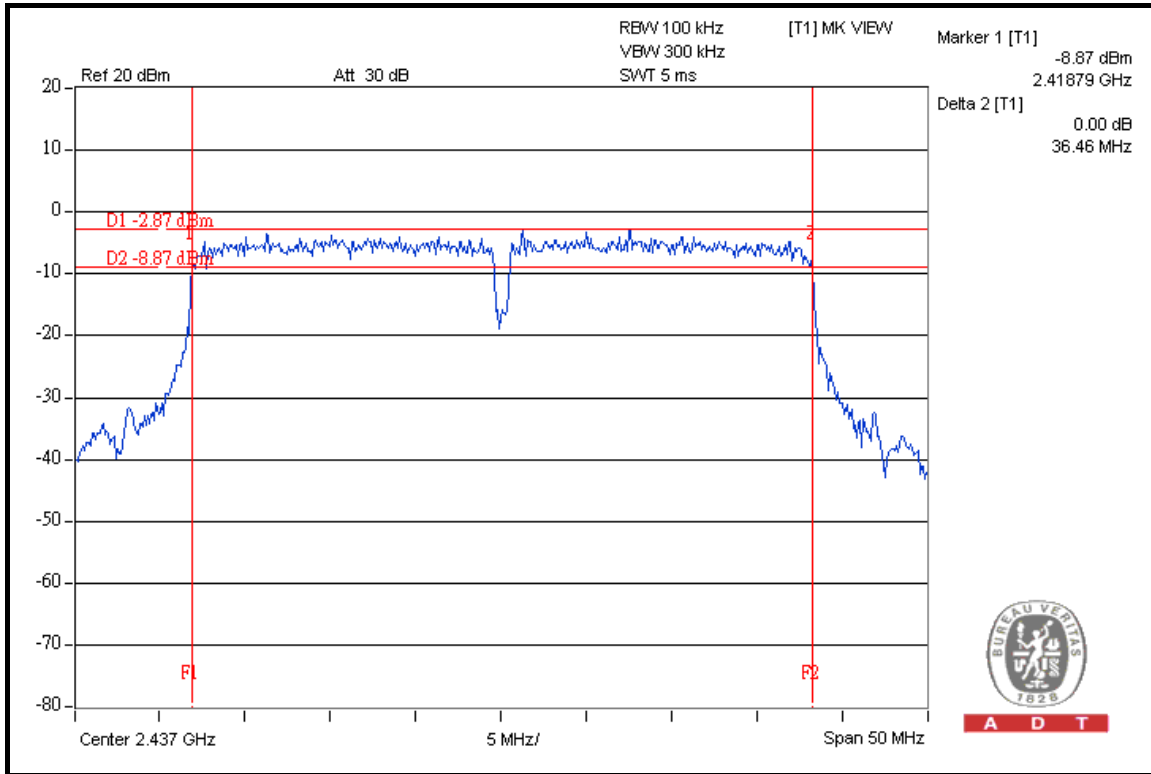

A D T

CH 7

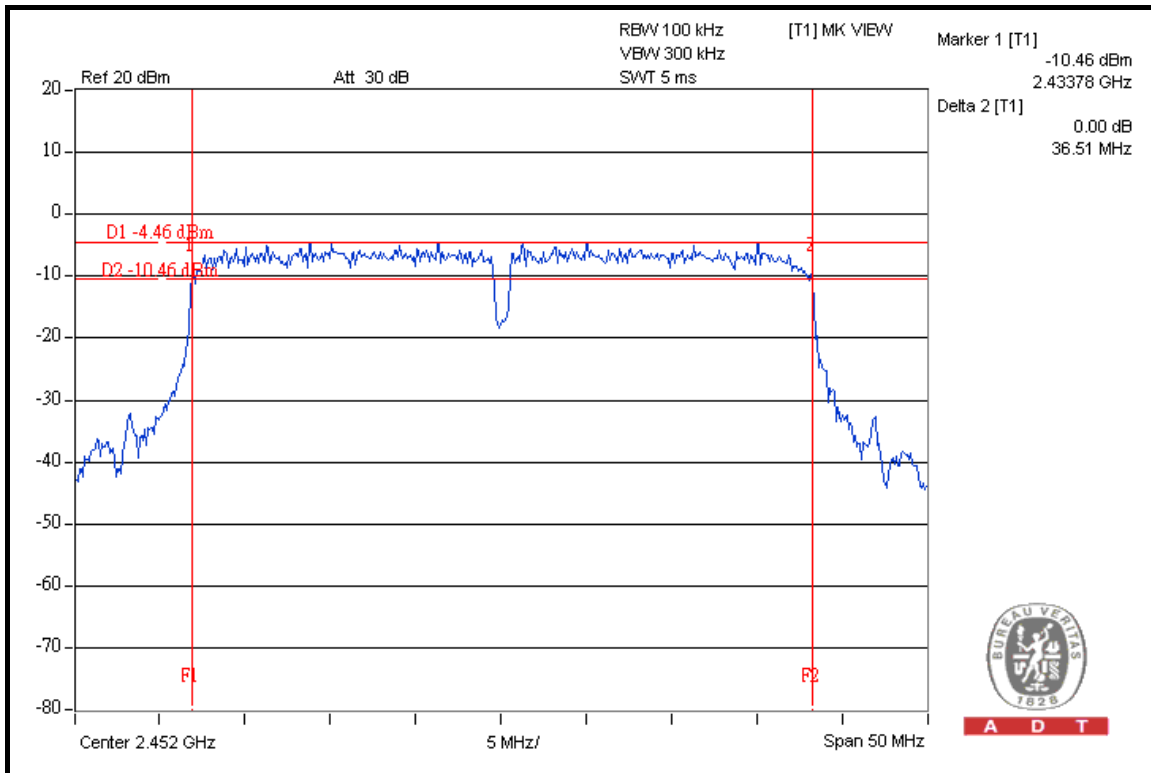

A D T

4.4 MAXIMUM PEAK OUTPUT POWER

4.4.1 LIMITS OF MAXIMUM PEAK OUTPUT POWER MEASUREMENT

The Maximum Peak Output Power Measurement is 30dBm.

4.4.2 INSTRUMENTS

DESCRIPTION & MANUFACTURER	MODEL NO.	SERIAL NO.	DATE OF CALIBRATION	DUE DATE OF CALIBRATION
HIGH SPEED PEAK POWER METER	ML2495A	0824012	Aug. 04, 2008	Aug. 03, 2009
POWER SENSOR	MA2444B	0738138	Aug. 04, 2008	Aug. 03, 2009

NOTE:

1. The calibration interval of the above test instruments is 12 months and the calibrations are traceable to NML/ROC and NIST/USA.
2. Measurement Bandwidth of ML2495A is 65MHz greater than 6dB bandwidth of emission.

4.4.3 TEST PROCEDURES

A power sensor was used on the output port of the EUT. A power meter was used to read the response of the power sensor. Record the power level.

4.4.4 DEVIATION FROM TEST STANDARD

No deviation

4.4.5 TEST SETUP

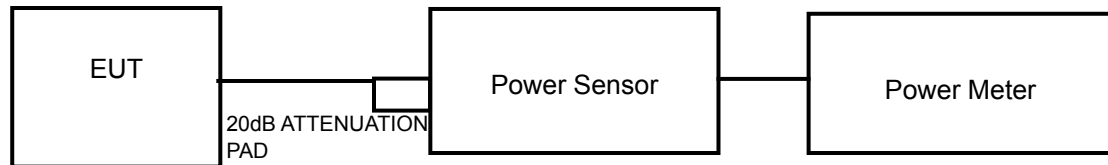

4.4.6 EUT OPERATING CONDITIONS

Same as Item 4.3.6

4.4.7 TEST RESULTS

802.11b DSSS MODULATION: 1TX

MODULATION TYPE	DBPSK	TRANSFER RATE	1.0Mbps
INPUT POWER	120Vac, 60 Hz	ENVIRONMENTAL CONDITIONS	22deg.C, 63%RH, 991hPa
TESTED BY	Mark Liao		

CHAN	CHANNEL FREQUENCY (MHz)	PEAK POWER OUTPUT (mW)	PEAK POWER OUTPUT (dBm)	PEAK POWER LIMIT (dBm)	PASS/FAIL
1	2412	127.644	21.06	30	PASS
6	2437	162.555	22.11	30	PASS
11	2462	159.588	22.03	30	PASS

802.11g OFDM MODULATIO: 1TX

MODULATION TYPE	BPSK	TRANSFER RATE	6.0Mbps
INPUT POWER	120Vac, 60 Hz	ENVIRONMENTAL CONDITIONS	22deg.C, 63%RH, 991hPa
TESTED BY	Mark Liao		

CHAN	CHANNEL FREQUENCY (MHz)	PEAK POWER OUTPUT (mW)	PEAK POWER OUTPUT (dBm)	PEAK POWER LIMIT (dBm)	PASS/FAIL
1	2412	252.930	24.03	30	PASS
6	2437	319.890	25.05	30	PASS
11	2462	255.859	24.08	30	PASS



A D T

DRAFT 802.11n (20MHz) OFDM MODULATION: 1TX

MODULATION TYPE	BPSK	TRANSFER RATE	7.2Mbps
INPUT POWER	120Vac, 60 Hz	ENVIRONMENTAL CONDITIONS	22deg.C, 63%RH, 991hPa
TESTED BY	Mark Liao		

CHAN	CHANNEL FREQUENCY (MHz)	PEAK POWER OUTPUT (mW)	PEAK POWER OUTPUT (dBm)	PEAK POWER LIMIT (dBm)	PASS/FAIL
1	2412	254.683	24.06	30	PASS
6	2437	319.154	25.04	30	PASS
11	2462	255.270	24.07	30	PASS

DRAFT 802.11n (20MHz) OFDM MODULATION: 2TX

MODULATION TYPE	BPSK	TRANSFER RATE	14.4Mbps
INPUT POWER	120Vac, 60 Hz	ENVIRONMENTAL CONDITIONS	22deg.C, 63%RH, 991hPa
TESTED BY	Mark Liao		

CHANNEL	CHANNEL FREQUENCY (MHz)	PEAK POWER OUTPUT (dBm)		TOTAL PEAK POWER (mW)	TOTAL PEAK POWER (dBm)	PEAK POWER LIMIT (dBm)	PASS / FAIL
		CHAIN 0	CHAIN 1				
1	2412	23.05	23.02	402.284	26.05	30	PASS
6	2437	23.57	23.54	453.453	26.57	30	PASS
11	2462	22.09	22.04	321.764	25.08	30	PASS

DRAFT 802.11n (40MHz) OFDM MODULATION: 1TX

MODULATION TYPE	BPSK	TRANSFER RATE	15.0Mbps
INPUT POWER	120Vac, 60 Hz	ENVIRONMENTAL CONDITIONS	22deg.C, 63%RH, 991hPa
TESTED BY	Mark Liao		

CHAN	CHANNEL FREQUENCY (MHz)	PEAK POWER OUTPUT (mW)	PEAK POWER OUTPUT (dBm)	PEAK POWER LIMIT (dBm)	PASS/FAIL
1	2422	255.859	24.08	30	PASS
4	2437	319.890	25.05	30	PASS
7	2452	253.513	24.04	30	PASS

DRAFT 802.11n (40MHz) OFDM MODULATION: 2TX

MODULATION TYPE	BPSK	TRANSFER RATE	30.0.Mbps
INPUT POWER	120Vac, 60 Hz	ENVIRONMENTAL CONDITIONS	22deg.C, 63%RH, 991hPa
TESTED BY	Mark Liao		

CHANNEL	CHANNEL FREQUENCY (MHz)	PEAK POWER OUTPUT (dBm)		TOTAL PEAK POWER (mW)	TOTAL PEAK POWER (dBm)	PEAK POWER LIMIT (dBm)	PASS / FAIL
		CHAIN 0	CHAIN 1				
1	2422	21.56	21.52	285.125	24.55	30	PASS
4	2437	23.04	23.07	404.141	26.07	30	PASS
7	2452	21.52	21.54	284.467	24.54	30	PASS

4.5 POWER SPECTRAL DENSITY MEASUREMENT

4.5.1 LIMITS OF POWER SPECTRAL DENSITY MEASUREMENT

The Maximum of Power Spectral Density Measurement is 8dBm.

4.5.2 TEST INSTRUMENTS

DESCRIPTION & MANUFACTURER	MODEL NO.	SERIAL NO.	DATE OF CALIBRATION	DUE DATE OF CALIBRATION
SPECTRUM ANALYZER	FSP 40	100041	Apr. 22, 2008	Apr. 21, 2009

NOTE: The calibration interval of the above test instruments is 12 months and the calibrations are traceable to NML/ROC and NIST/USA.

4.5.3 TEST PROCEDURE

The transmitter output was connected to the spectrum analyzer through an attenuator, the bandwidth of the fundamental frequency was measured with the spectrum analyzer using 3kHz RBW and 30kHz VBW, set sweep time = span/3kHz. The power spectral density was measured and recorded.

The sweep time is allowed to be longer than span/3kHz for a full response of the mixer in the spectrum analyzer.

4.5.4 DEVIATION FROM TEST STANDARD

No deviation

4.5.5 TEST SETUP

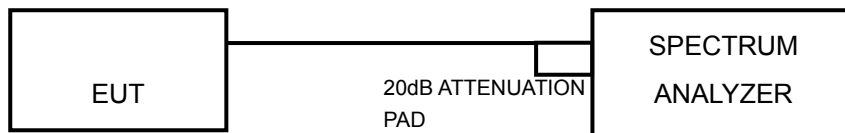

4.5.6 EUT OPERATING CONDITION

Same as Item 4.3.6



A D T

4.5.7 TEST RESULTS

802.11b DSSS MODULATION: 1TX

MODULATION TYPE	DBPSK	TRANSFER RATE	1.0Mbps
INPUT POWER	120Vac, 60 Hz	ENVIRONMENTAL CONDITIONS	22deg.C, 63%RH, 991hPa
TESTED BY	Mark Liao		

CHANNEL	CHANNEL FREQUENCY (MHz)	RF POWER LEVEL IN 3 kHz BW (dBm)	MAXIMUM LIMIT (dBm)	PASS/FAIL
1	2412	-13.27	8	PASS
6	2437	-12.15	8	PASS
11	2462	-12.13	8	PASS

CH 1

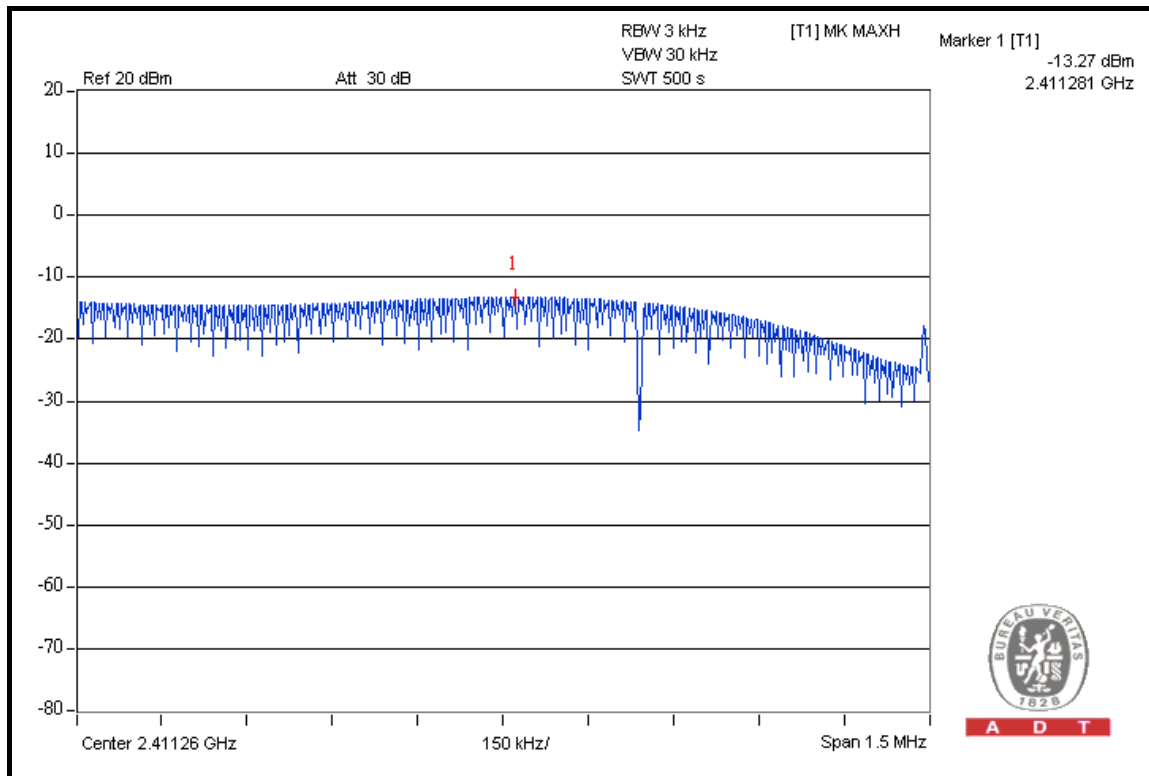

A D T



A D T

CH 6

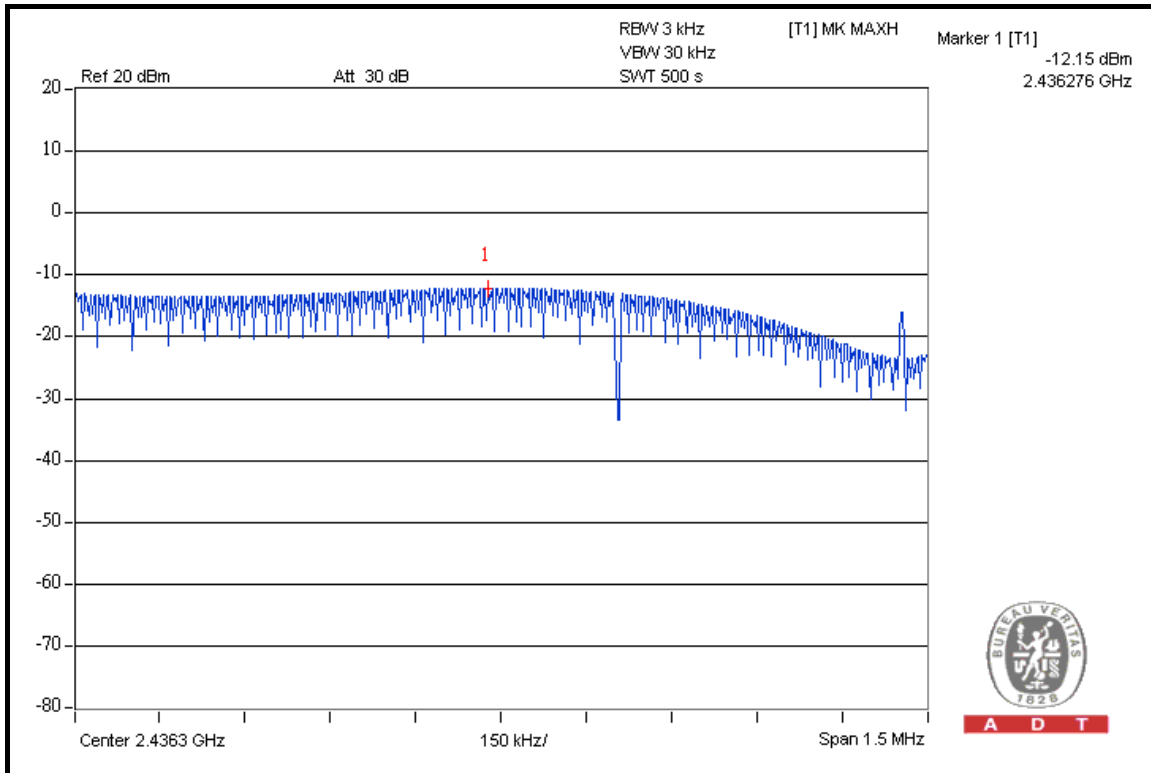

CH 11

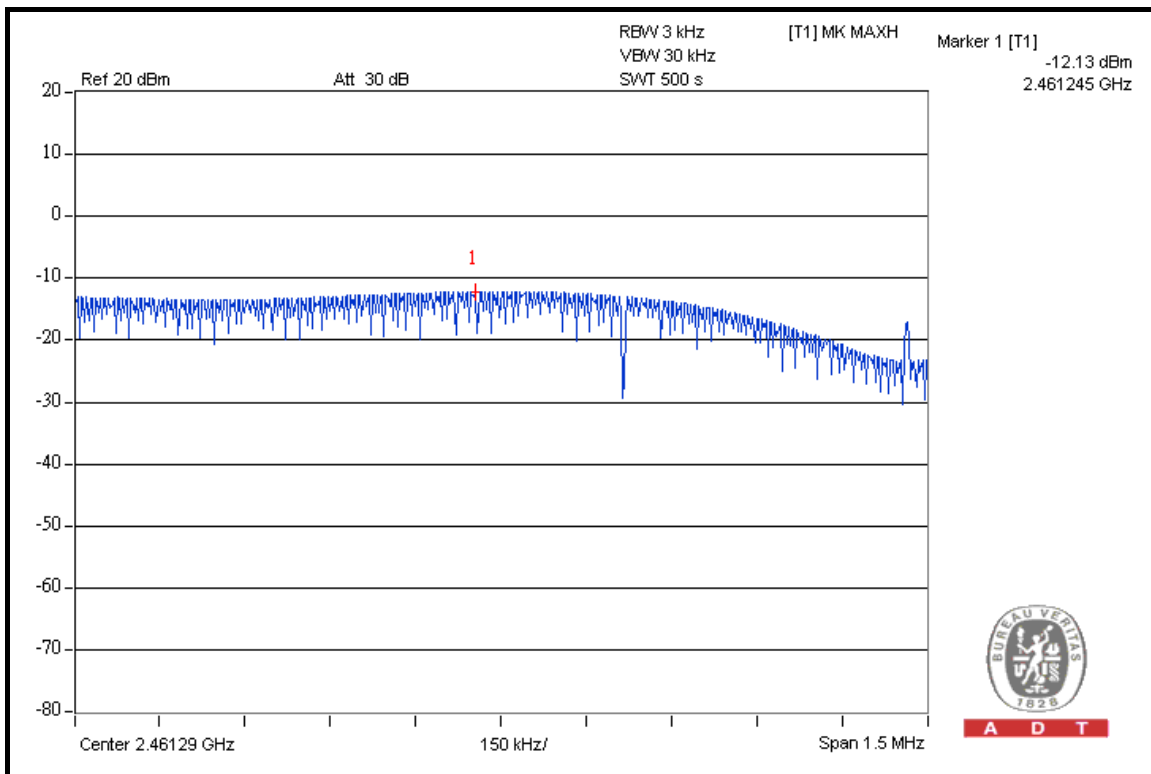



A D T

802.11g OFDM MODULATION: 1TX

MODULATION TYPE	BPSK	TRANSFER RATE	6.0Mbps
INPUT POWER	120Vac, 60 Hz	ENVIRONMENTAL CONDITIONS	22deg.C, 63%RH, 991hPa
TESTED BY	Mark Liao		

CHANNEL	CHANNEL FREQUENCY (MHz)	RF POWER LEVEL IN 3 kHz BW (dBm)	MAXIMUM LIMIT (dBm)	PASS/FAIL
1	2412	-13.22	8	PASS
6	2437	-12.24	8	PASS
11	2462	-13.20	8	PASS

CH 1

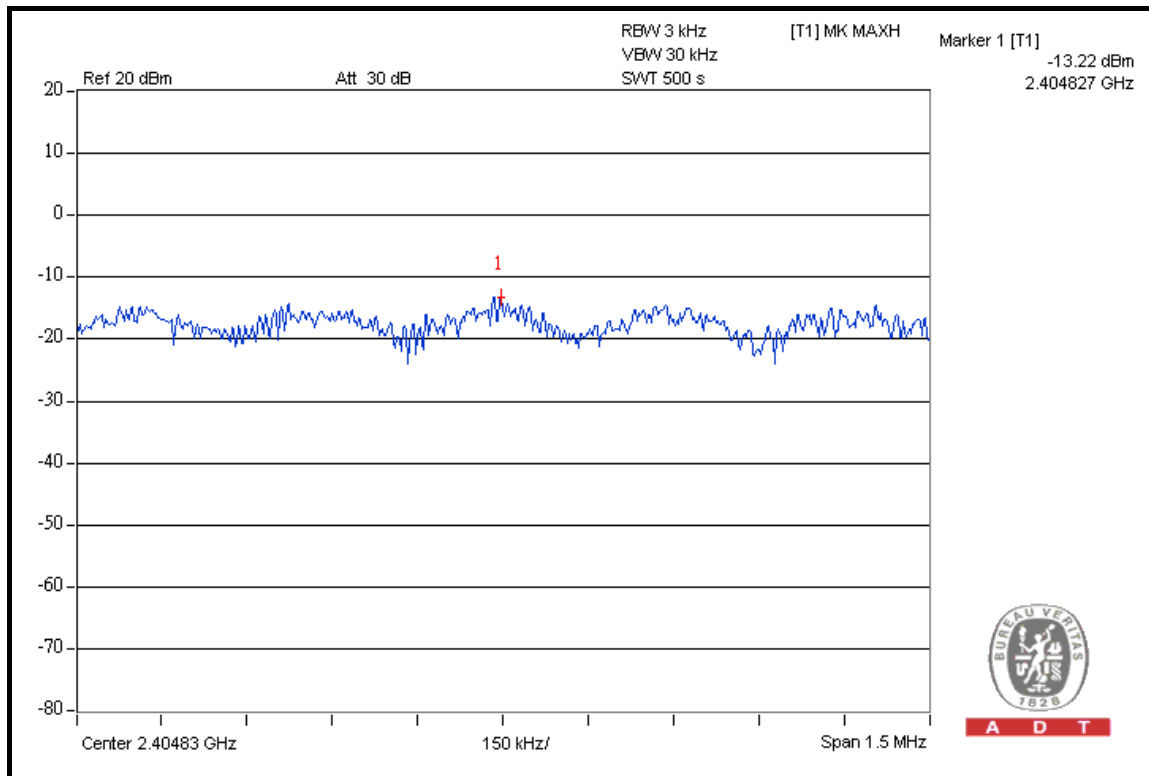

A D T



A D T

CH 6

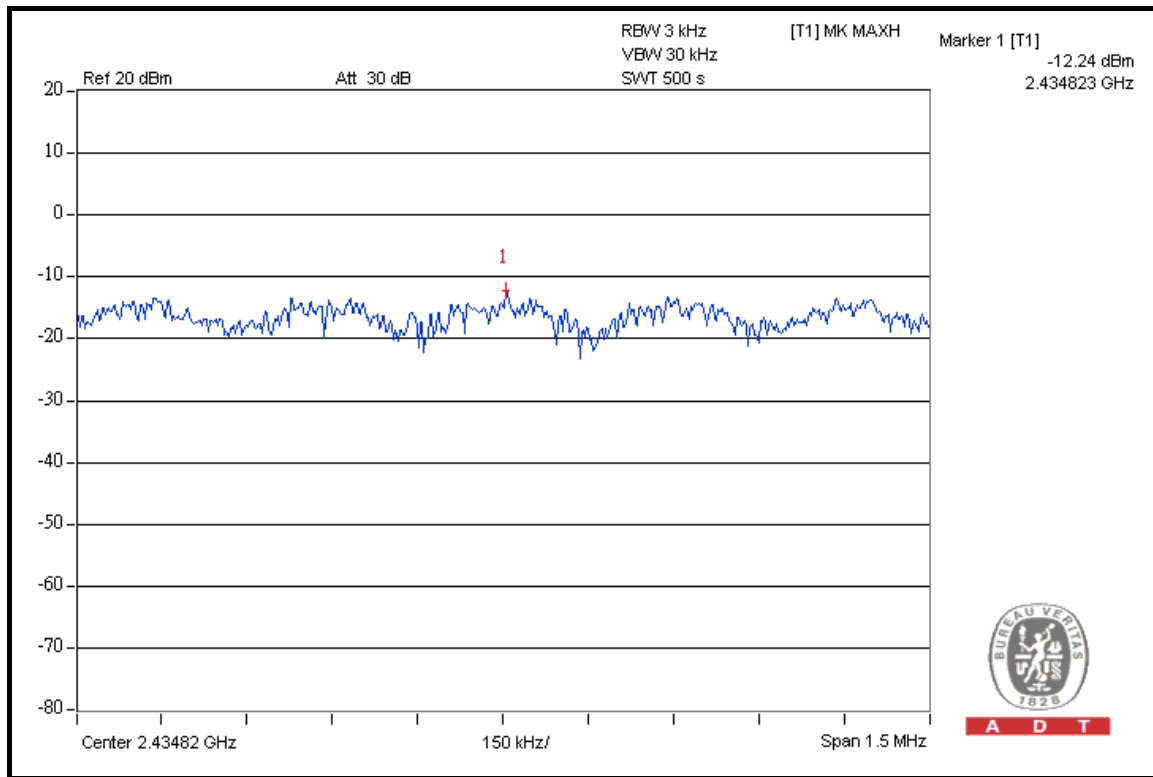

CH 11

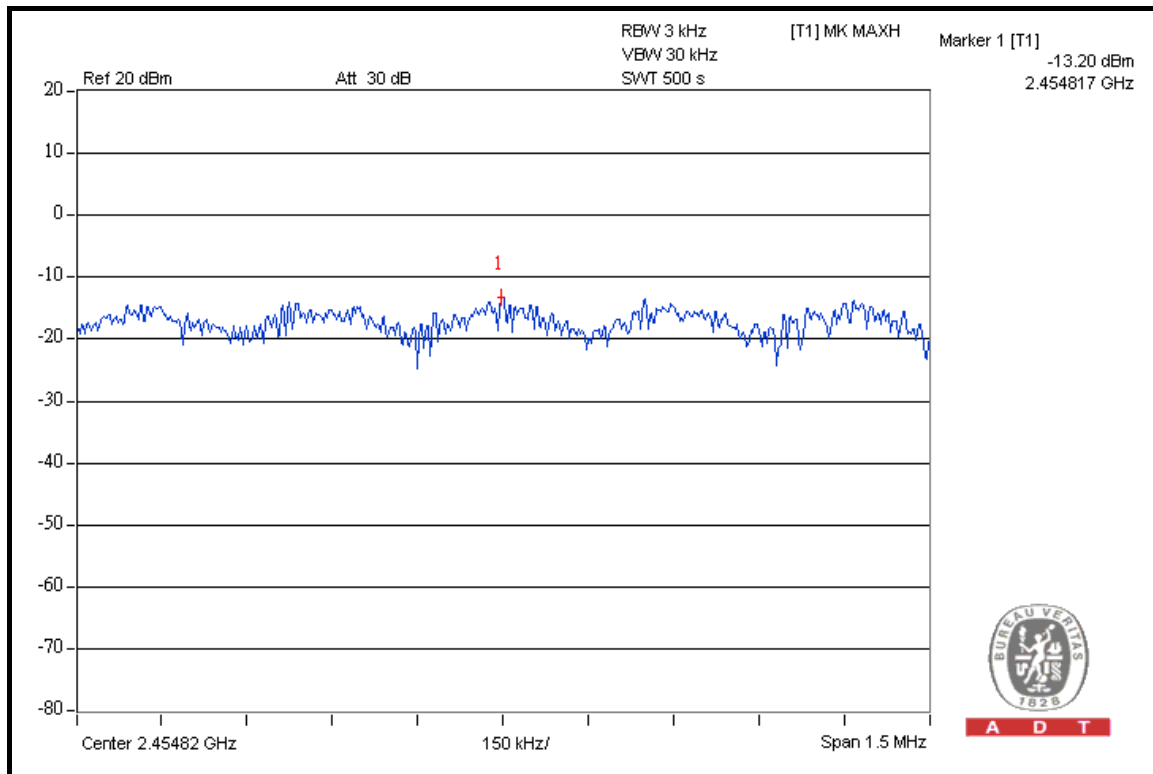



A D T

DRAFT 802.11n (20MHz) OFDM MODULATION: 1TX

MODULATION TYPE	BPSK	TRANSFER RATE	7.2Mbps
INPUT POWER	120Vac, 60 Hz	ENVIRONMENTAL CONDITIONS	22deg.C, 63%RH, 991hPa
TESTED BY	Mark Liao		

CHANNEL	CHANNEL FREQUENCY (MHz)	RF POWER LEVEL IN 3 kHz BW (dBm)	MAXIMUM LIMIT (dBm)	PASS/FAIL
1	2412	-13.28	8	PASS
6	2437	-12.32	8	PASS
11	2462	-13.23	8	PASS

CH 1

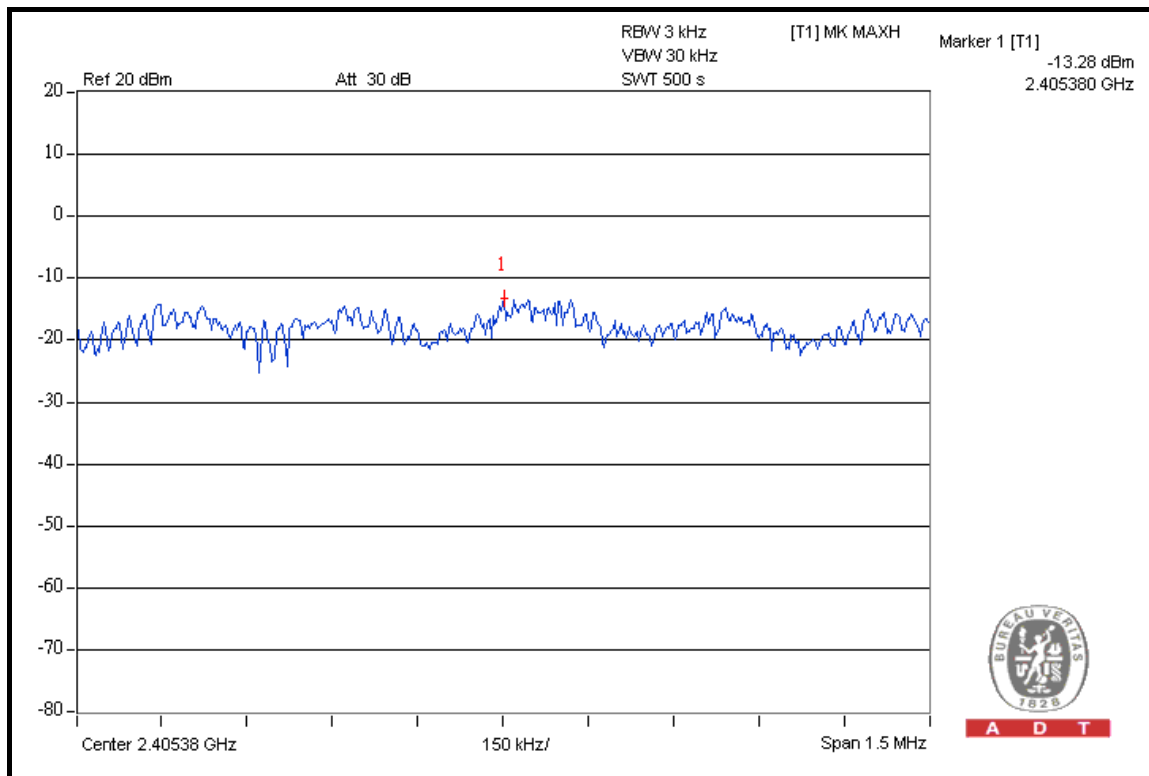

A D T



A D T

CH 6

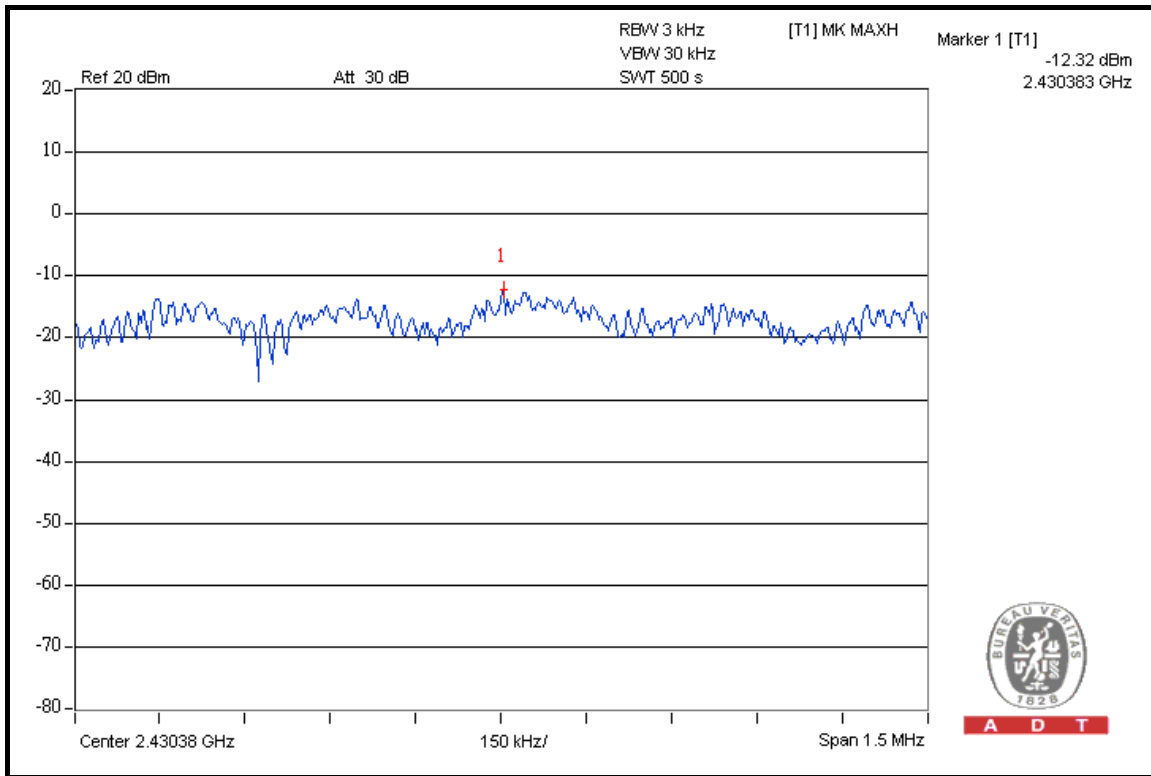

CH 11

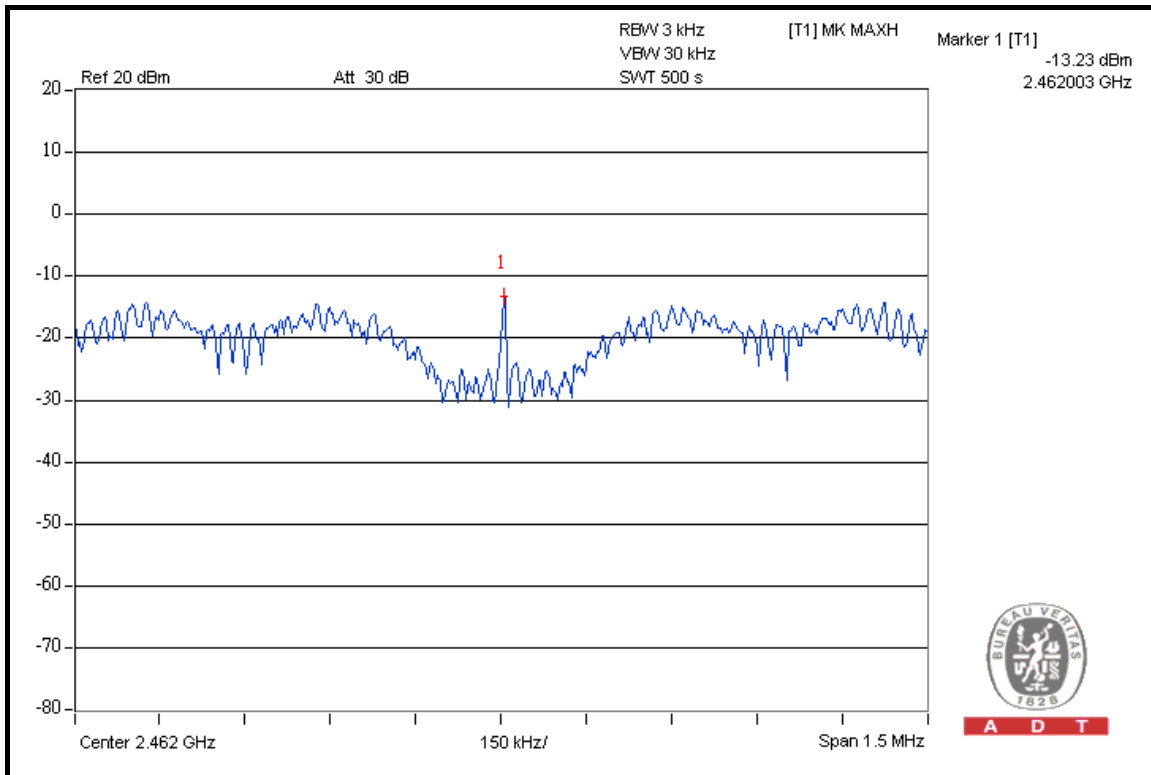



A D T

DRAFT 802.11n (20MHz) OFDM MODULATION: 2TX

MODULATION TYPE	BPSK	TRANSFER RATE	14.4Mbps
INPUT POWER	120Vac, 60 Hz	ENVIRONMENTAL CONDITIONS	22deg.C, 63%RH, 991hPa
TESTED BY	Mark Liao		

CHANNEL	CHANNEL FREQUENCY (MHz)	RF POWER LEVEL IN 3kHz BW (dBm)		TOTAL POWER DENSITY (mW)	TOTAL POWER DENSITY (dBm)	MAX. LIMIT (dBm)	PASS / FAIL
		CHAIN 0	CHAIN 1				
1	2412	-15.09	-14.51	0.066	-11.78	8	PASS
6	2437	-14.49	-14.07	0.075	-11.26	8	PASS
11	2462	-16.04	-15.75	0.051	-12.88	8	PASS



A D T

FOR CHAIN 0: CH 1

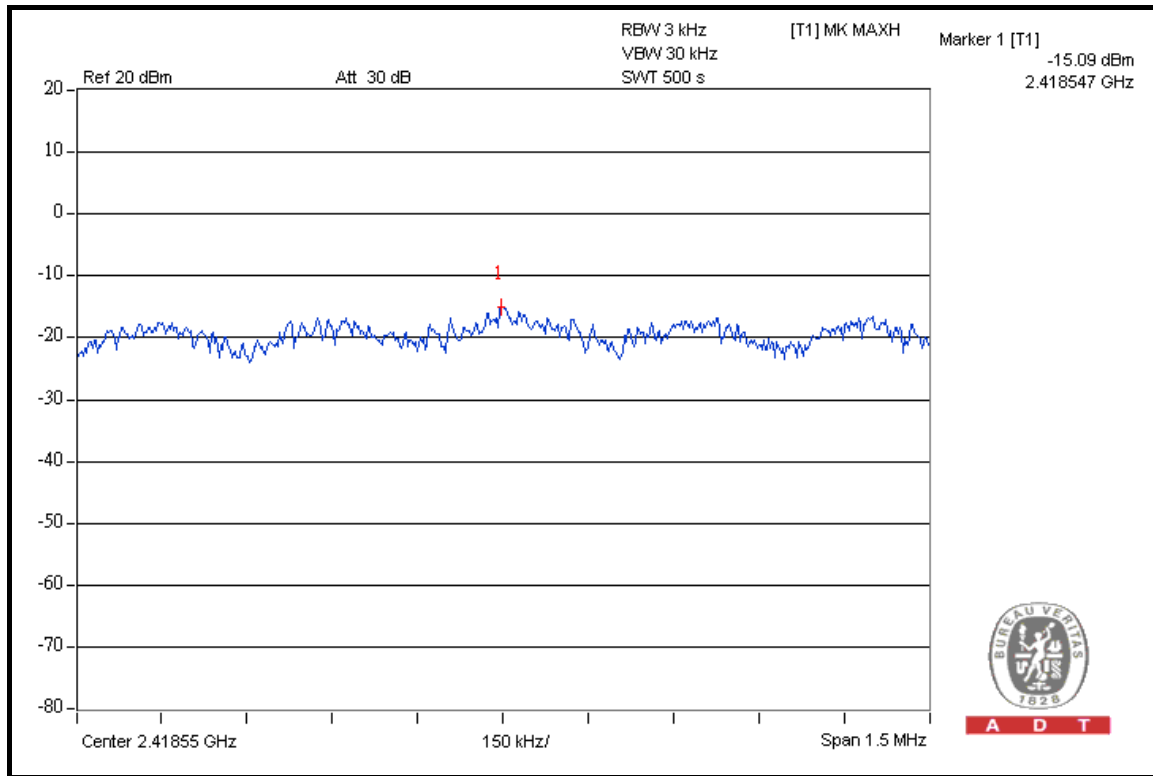

CH 6

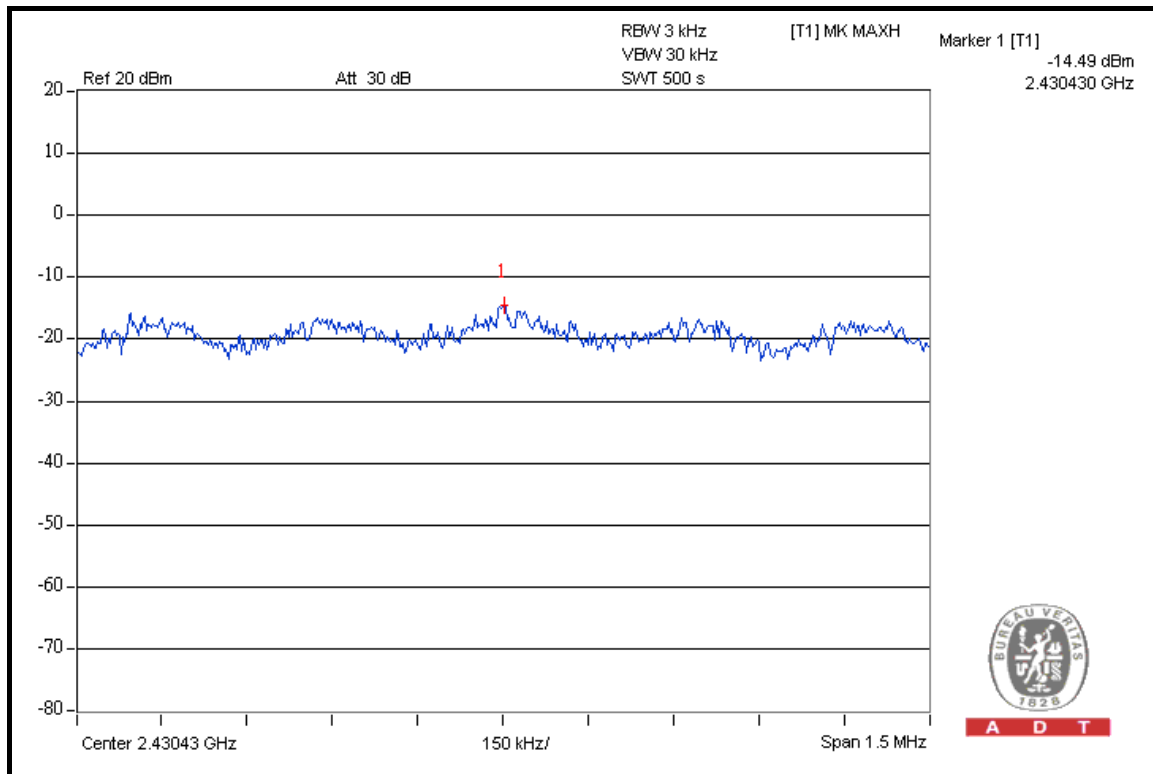



A D T

CH 11

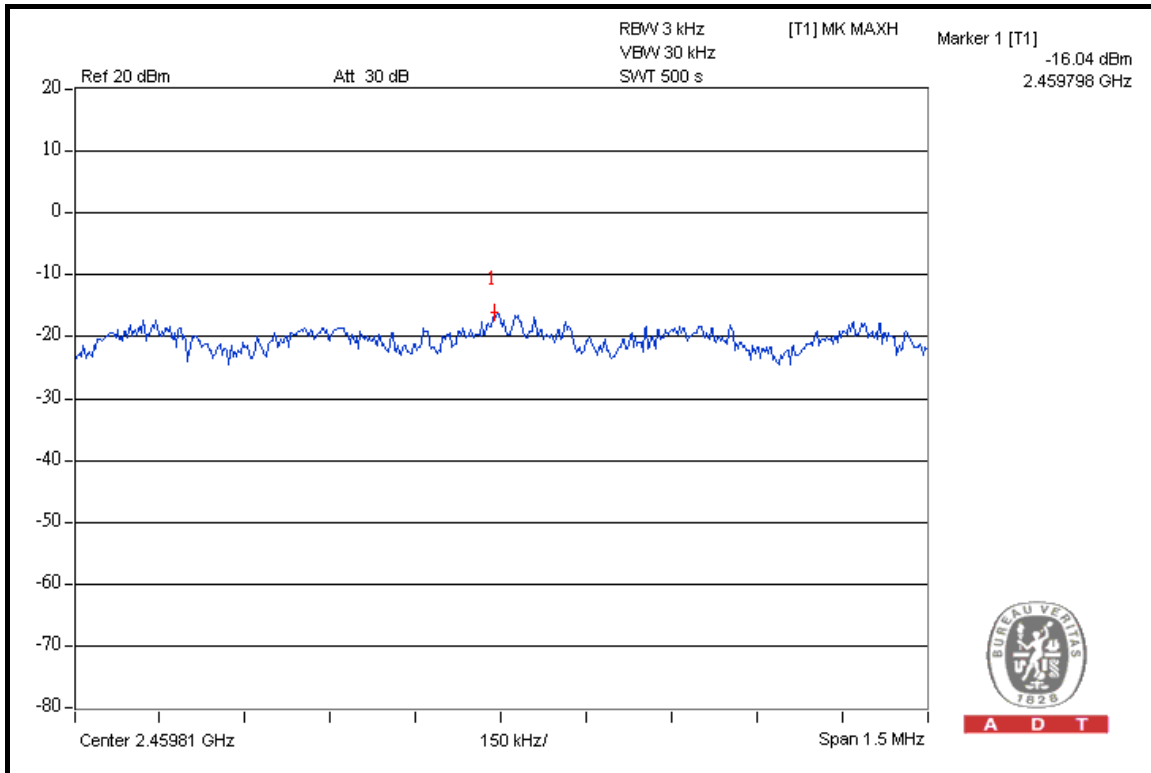

FOR CHAIN 1: CH 1

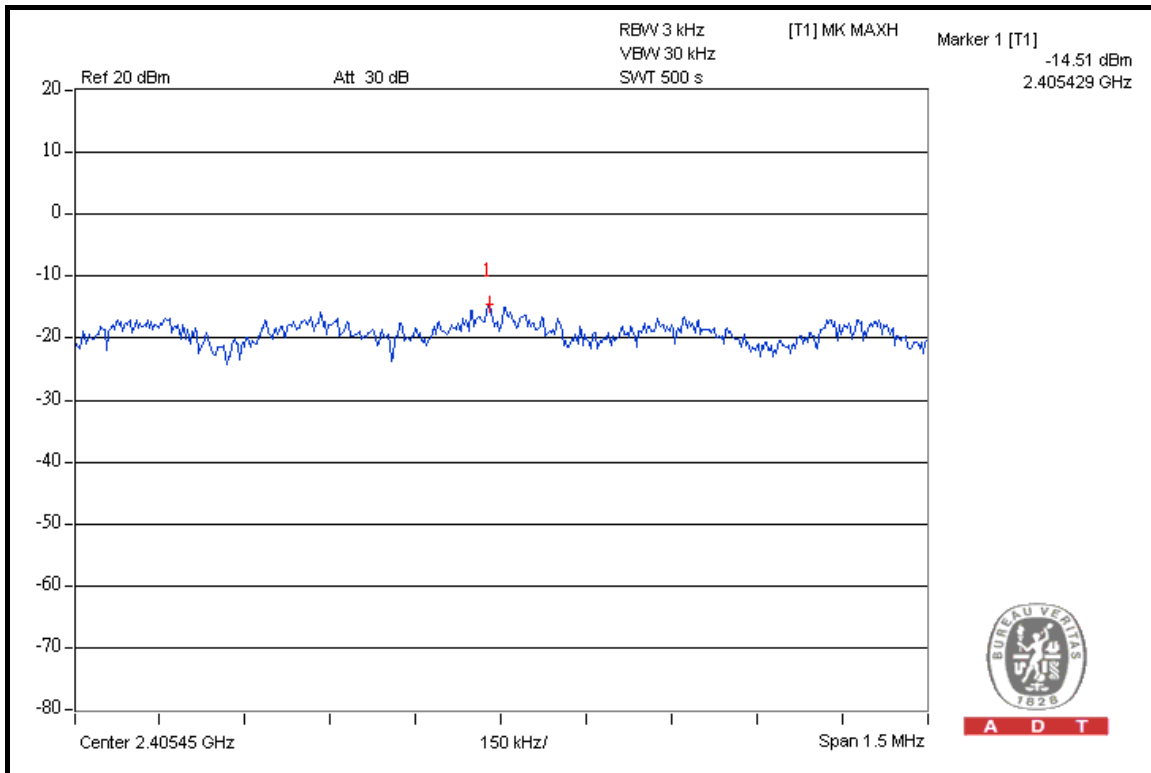



A D T

CH 6

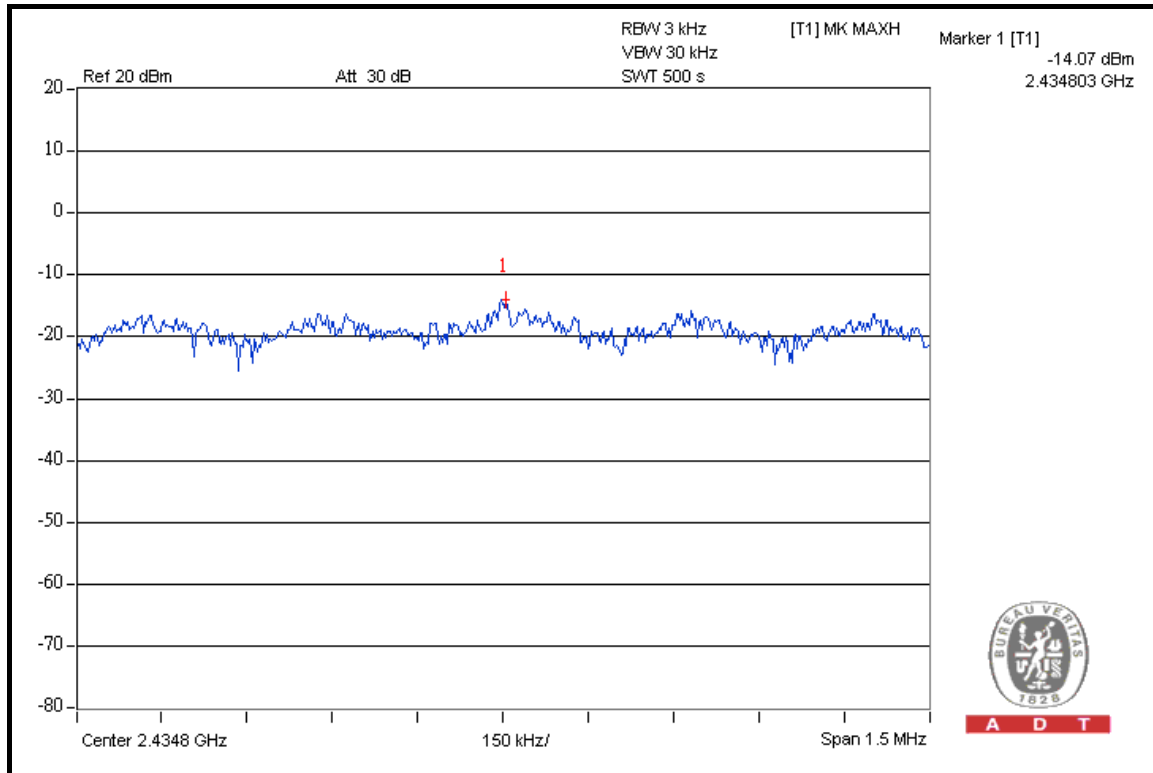

CH 11

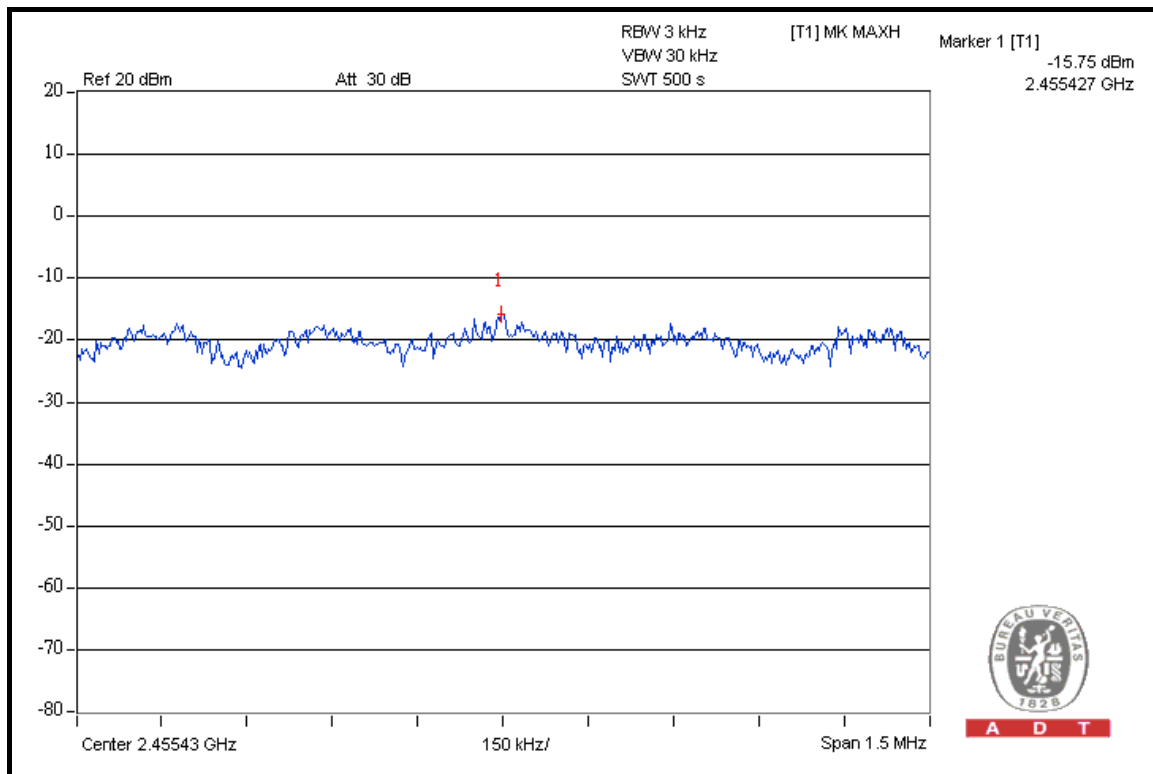



A D T

DRAFT 802.11n (40MHz) OFDM MODULATION: 1TX

MODULATION TYPE	BPSK	TRANSFER RATE	15.0Mbps
INPUT POWER	120Vac, 60 Hz	ENVIRONMENTAL CONDITIONS	22deg.C, 63%RH, 991hPa
TESTED BY	Mark Liao		

CHANNEL	CHANNEL FREQUENCY (MHz)	RF POWER LEVEL IN 3 kHz BW (dBm)	MAXIMUM LIMIT (dBm)	PASS/FAIL
1	2422	-14.29	8	PASS
4	2437	-13.31	8	PASS
7	2452	-14.28	8	PASS

CH 1

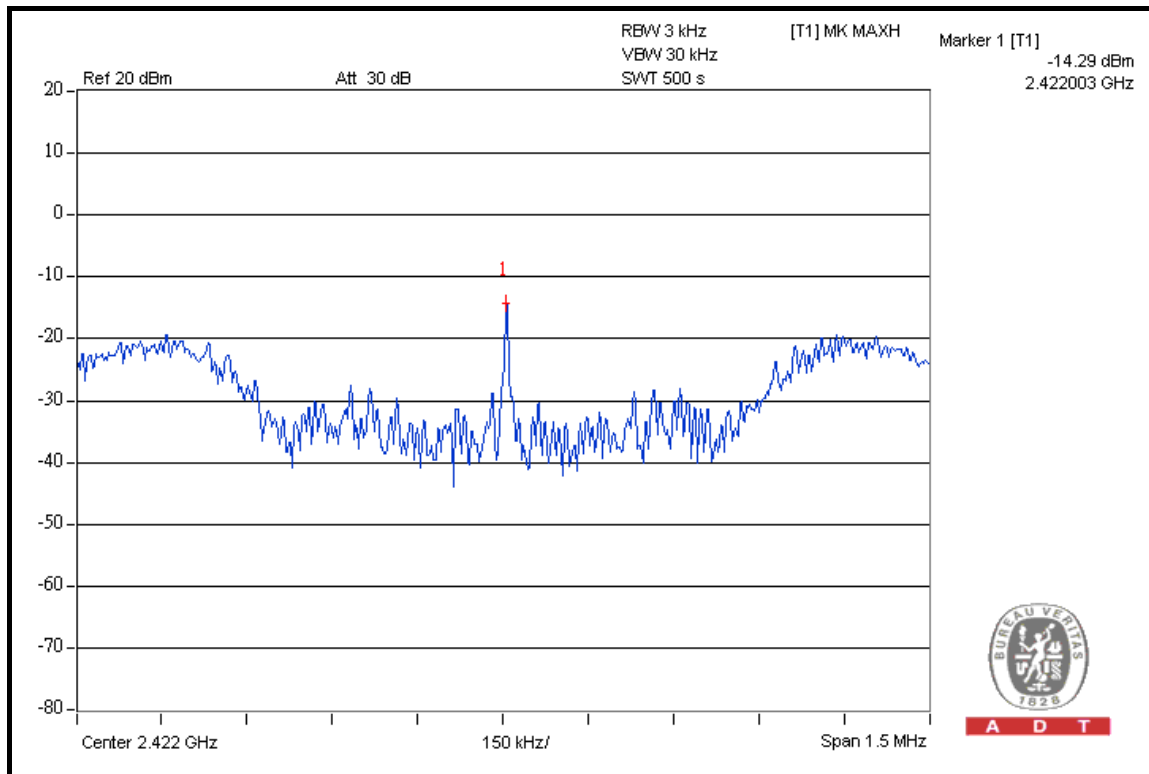

A D T



A D T

CH 4

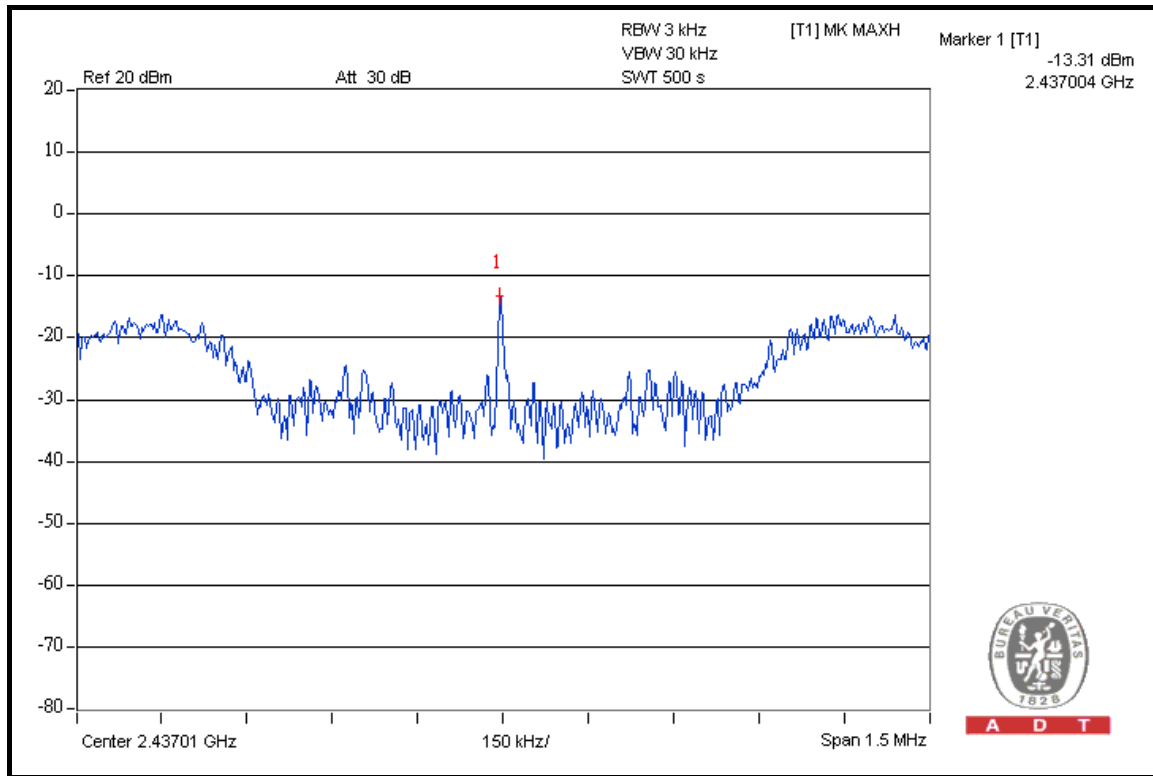

CH 7

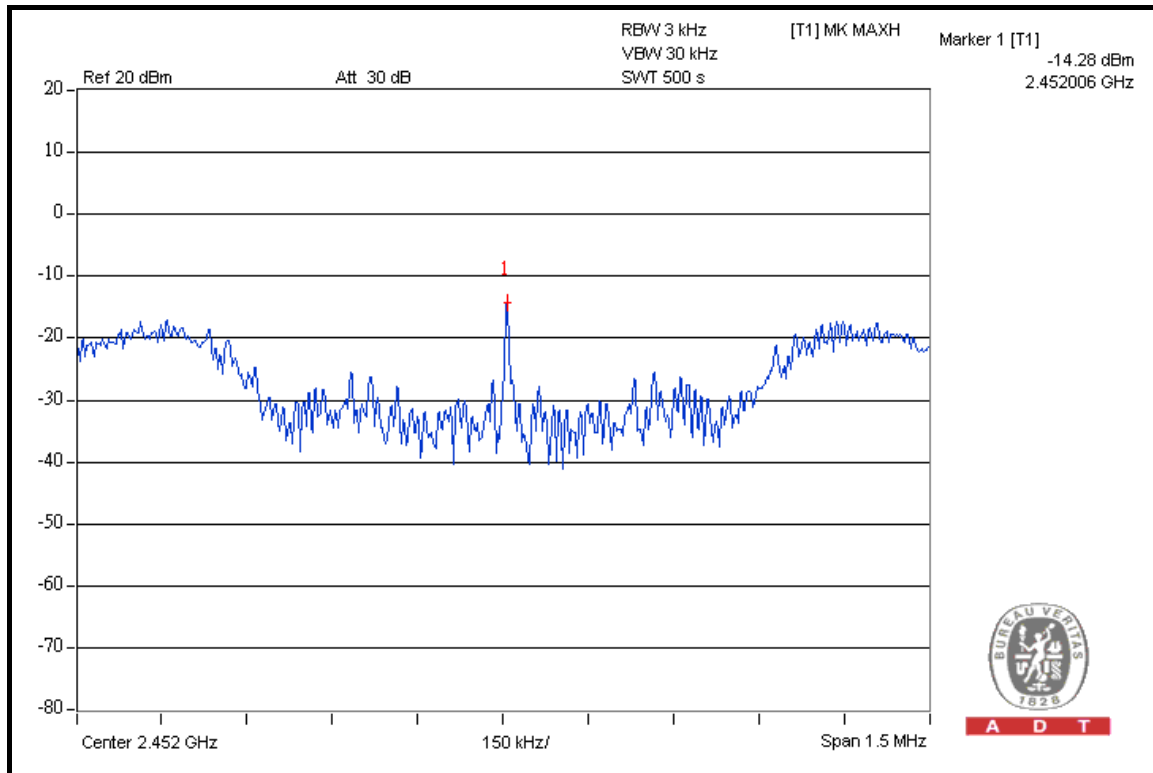



A D T

DRAFT 802.11n (40MHz) OFDM MODULATION: 2TX

MODULATION TYPE	BPSK	TRANSFER RATE	30.0Mbps
INPUT POWER	120Vac, 60 Hz	ENVIRONMENTAL CONDITIONS	22deg.C, 63%RH, 991hPa
TESTED BY	Mark Liao		

CHANNEL	CHANNEL FREQUENCY (MHz)	RF POWER LEVEL IN 3kHz BW (dBm)		TOTAL POWER DENSITY (mW)	TOTAL POWER DENSITY (dBm)	MAX. LIMIT (dBm)	PASS / FAIL
		CHAIN 0	CHAIN 1				
1	2422	-17.35	-18.39	0.033	-14.83	8	PASS
4	2437	-15.68	-17.04	0.047	-13.30	8	PASS
7	2452	-17.11	-18.22	0.035	-14.62	8	PASS



A D T

FOR CHAIN 0: CH 1

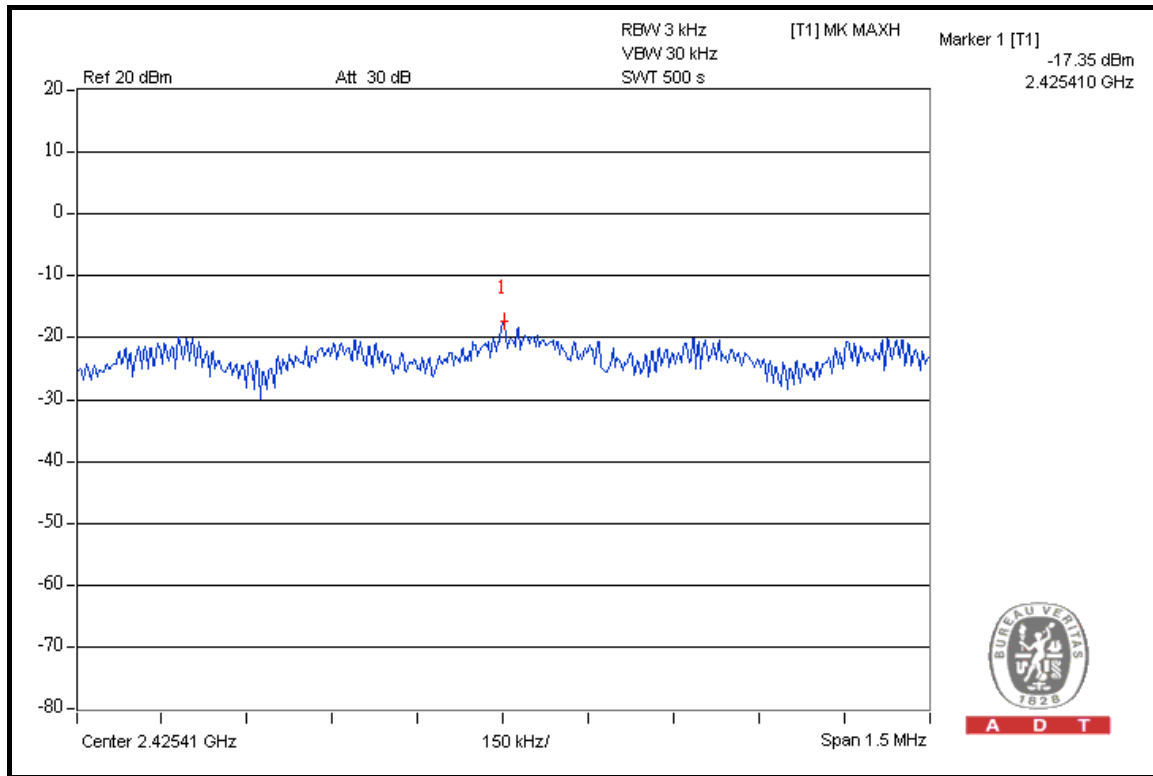

CH 4

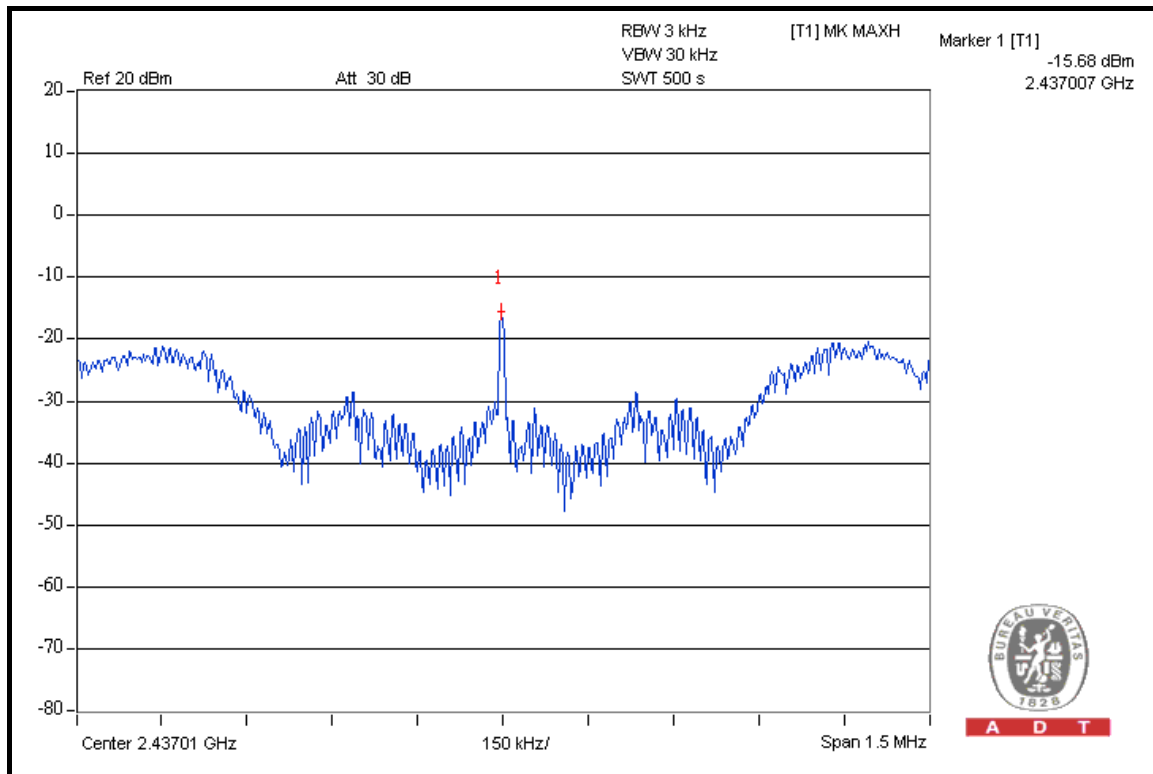



A D T

CH 7

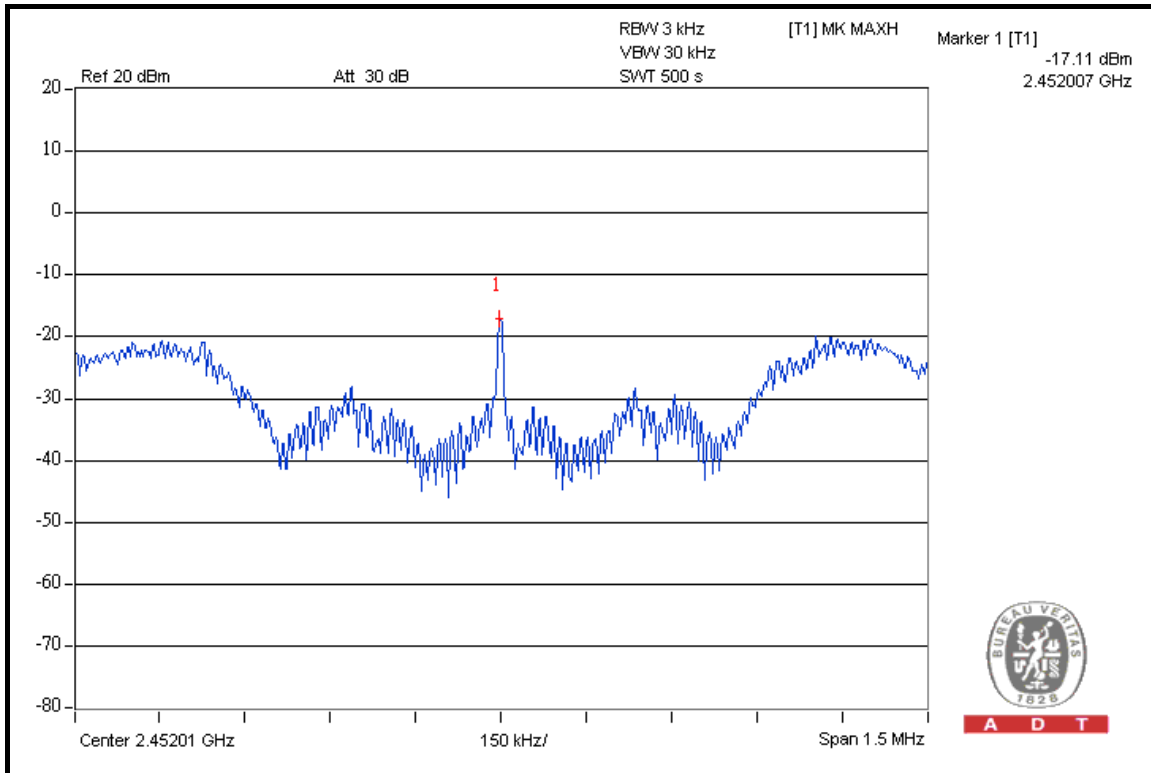

FOR CHAIN 1: CH 1

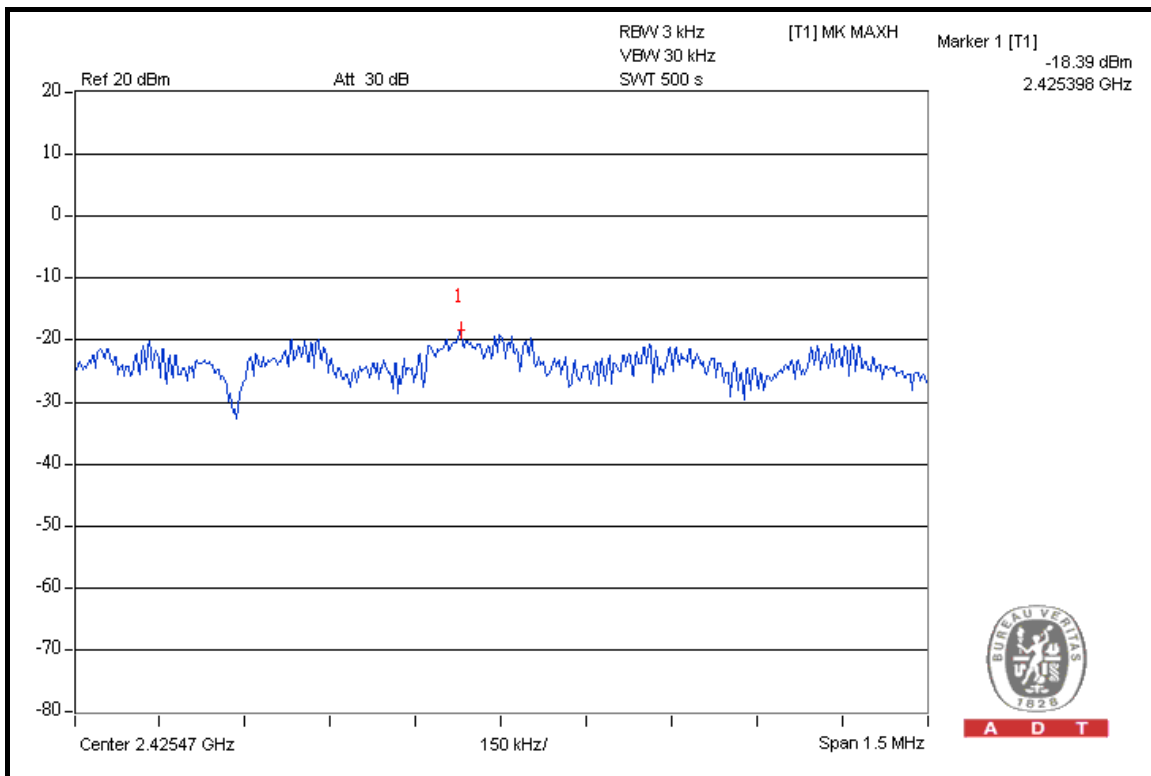



A D T

CH 4

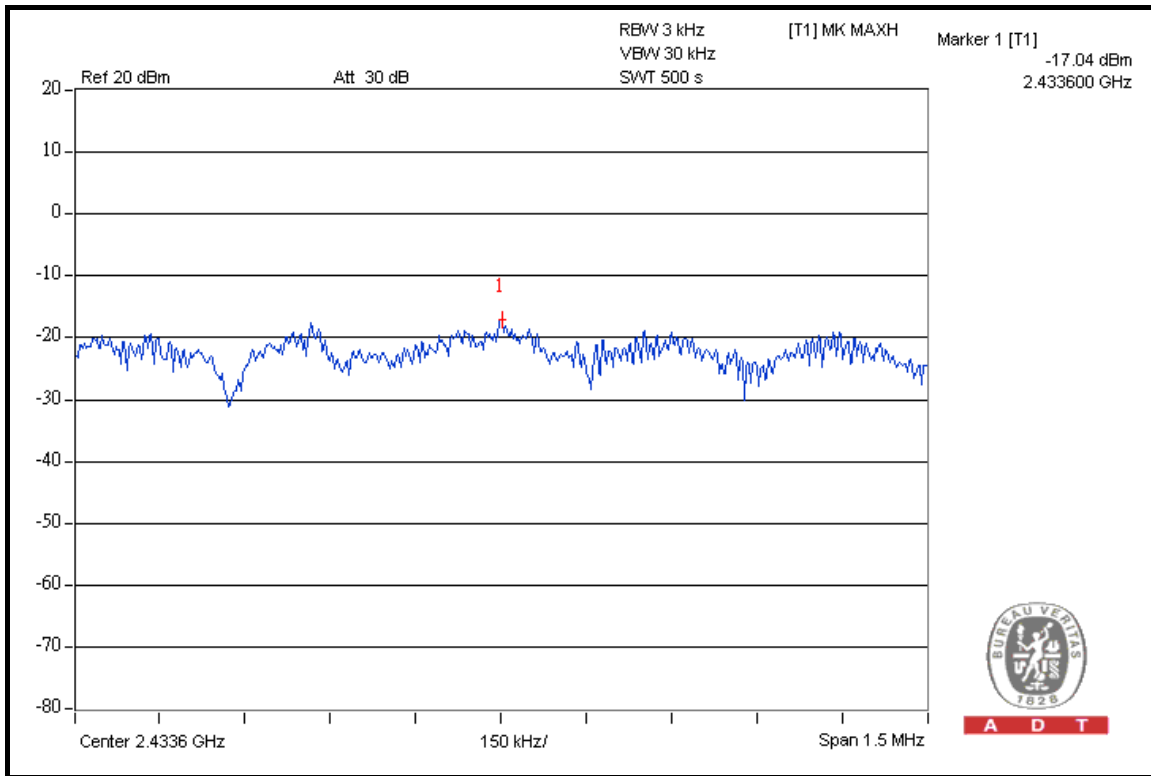

CH 7

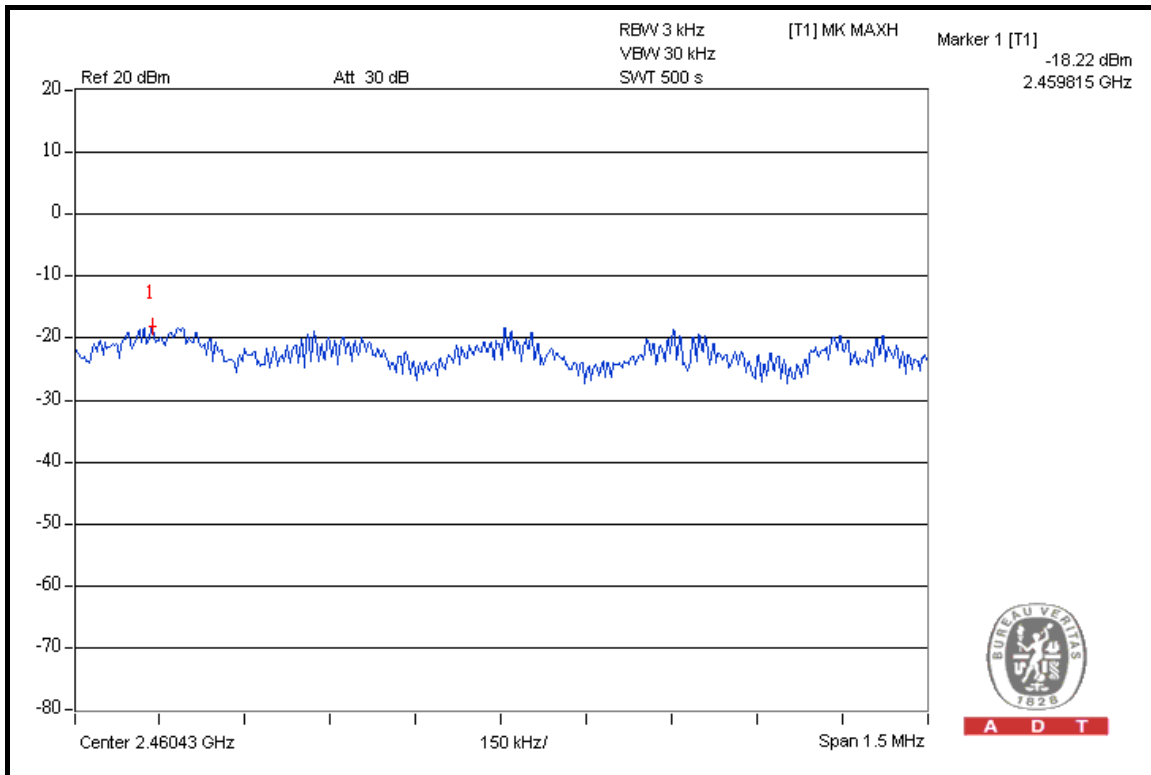

4.6 BAND EDGES MEASUREMENT

4.6.1 LIMITS OF BAND EDGES MEASUREMENT

Below –20dB of the highest emission level of operating band (in 100kHz Resolution Bandwidth).

4.6.2 TEST INSTRUMENTS

DESCRIPTION & MANUFACTURER	MODEL NO.	SERIAL NO.	DATE OF CALIBRATION	DUE DATE OF CALIBRATION
FOR CONDUCTED MEASUREMENT				
SPECTRUM ANALYZER	FSP 40	100041	Apr. 22, 2008	Apr. 21, 2009
FOR RADIATED MEASUREMENT				
Test Receiver ROHDE & SCHWARZ	ESIB7	100212	May 28, 2008	May 27, 2009
Spectrum Analyzer ROHDE & SCHWARZ	FSP40	100269	Aug. 08, 2008	Aug. 07, 2009
BILOG Antenna SCHWARZBECK	VULB9168	9168-156	Apr. 25, 2008	Apr. 24, 2009
HORN Antenna SCHWARZBECK	BBHA 9170	BBHA9170242	Jan. 07, 2008	Jan. 06, 2009
Preamplifier Agilent	8449B	3008A01911	Sep. 10, 2008	Sep. 09, 2009
Preamplifier Agilent	8447D	2944A10634	Oct. 23, 2008	Oct. 22, 2009
RF signal cable HUBER+SUHNNER	SUCOFLEX 104	218190/4 231241/4	May 20, 2008	May 19, 2009
RF signal cable Worken	8D-FB	Cable-HYCH9-01	Aug. 09, 2008	Aug. 08, 2009
Software	ADT_Radiated_ V7.6.15.9.2	NA	NA	NA
Antenna Tower EMCO	2070/2080	512.835.4684	NA	NA
Turn Table EMCO	2087-2.03	NA	NA	NA
Antenna Tower & Turn Table Controller EMCO	2090	NA	NA	NA

NOTE: The calibration interval of the above test instruments is 12 months and the calibrations are traceable to NML/ROC and NIST/USA.

4.6.3 TEST PROCEDURE

FOR CONDUCTED MEASUREMENT

The transmitter output was connected to the spectrum analyzer via a low lose cable. Set both RBW and VBW of spectrum analyzer to 100kHz and 300kHz with suitable frequency span including 100MHz bandwidth from band edge. The band edges was measured and recorded.

The spectrum plots (Peak RBW = 100kHz, VBW = 300kHz; Average RBW = 1MHz, VBW = 1kHz) are attached on the following pages.

FOR RADIATED MEASUREMENT

- a. The EUT was placed on the top of a rotating table 0.8 meters above the ground at a 3 meter semi-anechoic chamber. The table was rotated 360 degrees to determine the position of the highest radiation.
- b. The EUT was set 3 meters away from the interference-receiving antenna, which was mounted on the top of a variable-height antenna tower.
- c. The antenna is a broadband antenna, and its height is varied from one meter to four meters above the ground to determine the maximum value of the field strength. Both horizontal and vertical polarizations of the antenna are set to make the measurement.
- d. For each suspected emission, the EUT was arranged to its worst case and then the antenna was tuned to heights from 1 meter to 4 meters and the rotatable table was turned from 0 degrees to 360 degrees to find the maximum reading.
- e. Set both RBW and VBW of spectrum analyzer to 100kHz with suitable frequency span including 100MHz bandwidth from band edge. The band edges was measured and recorded.

The spectrum plots (Peak RBW = 100kHz, VBW = 300kHz; Average RBW = 1MHz, VBW = 1kHz)

4.6.4 DEVIATION FROM TEST STANDARD

No deviation

4.6.5 EUT OPERATING CONDITION

Same as Item 4.3.6

4.6.6 TEST RESULTS

The spectrum plots are attached on the following 24 images. D1 line indicates the highest level, and D2 line indicates the 20dB offset below D1. It shows compliance with the requirement in part 15.247(d).

802.11b DSSS MODULATION: 1TX

NOTE 1: The band edge emission plot on the next page shows 47.22dBc between carrier maximum power and local maximum emission in restrict band (2.3862GHz). The emission of carrier strength list in the test result of channel 1 at the item 4.1.7 is 106.55dBuV/m (Peak), so the maximum field strength in restrict band is $106.55 - 47.22 = 59.33$ dBuV/m which is under 74dBuV/m limit.

The band edge emission plot on the next page shows 49.44dBc between carrier maximum power and local maximum emission in restrict band (2.3864GHz). The emission of carrier strength list in the test result of channel 1 at the item 4.1.7 is 102.32dBuV/m (Average), so the maximum field strength in restrict band is $102.32 - 49.44 = 52.88$ dBuV/m which is under 54dBuV/m limit.

NOTE 2: The band edge emission plot on the next second page shows 47.04dBc between carrier maximum power and local maximum emission in restrict band (2.4880GHz). The emission of carrier strength list in the test result of channel 11 at the item 4.1.7 is 107.47dBuV/m (Peak), so the maximum field strength in restrict band is $107.47 - 47.04 = 60.43$ dBuV/m which is under 74dBuV/m limit.

The band edge emission plot on the next third page shows 50.95dBc between carrier maximum power and local maximum emission in restrict band (2.4878GHz). The emission of carrier strength list in the test result of channel 11 at the item 4.1.7 is 103.23dBuV/m (Average), so the maximum field strength in restrict band is $103.23 - 50.95 = 52.28$ dBuV/m which is under 54dBuV/m limit.



A D T

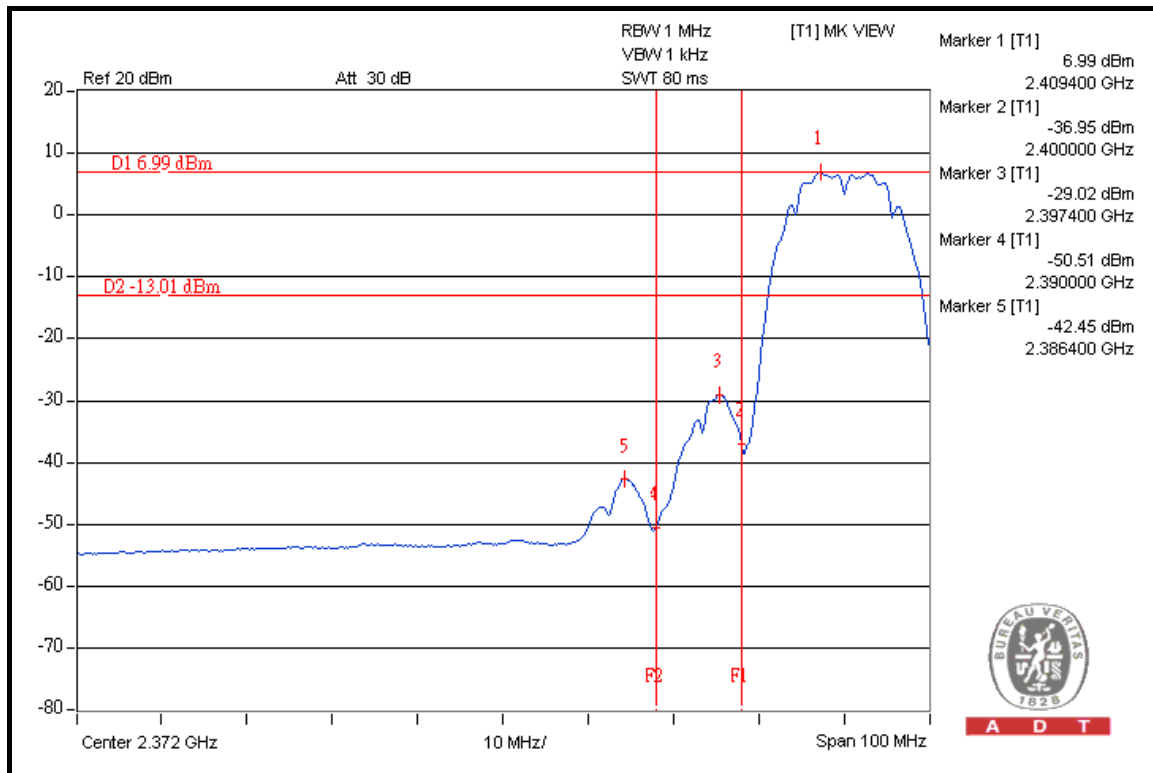
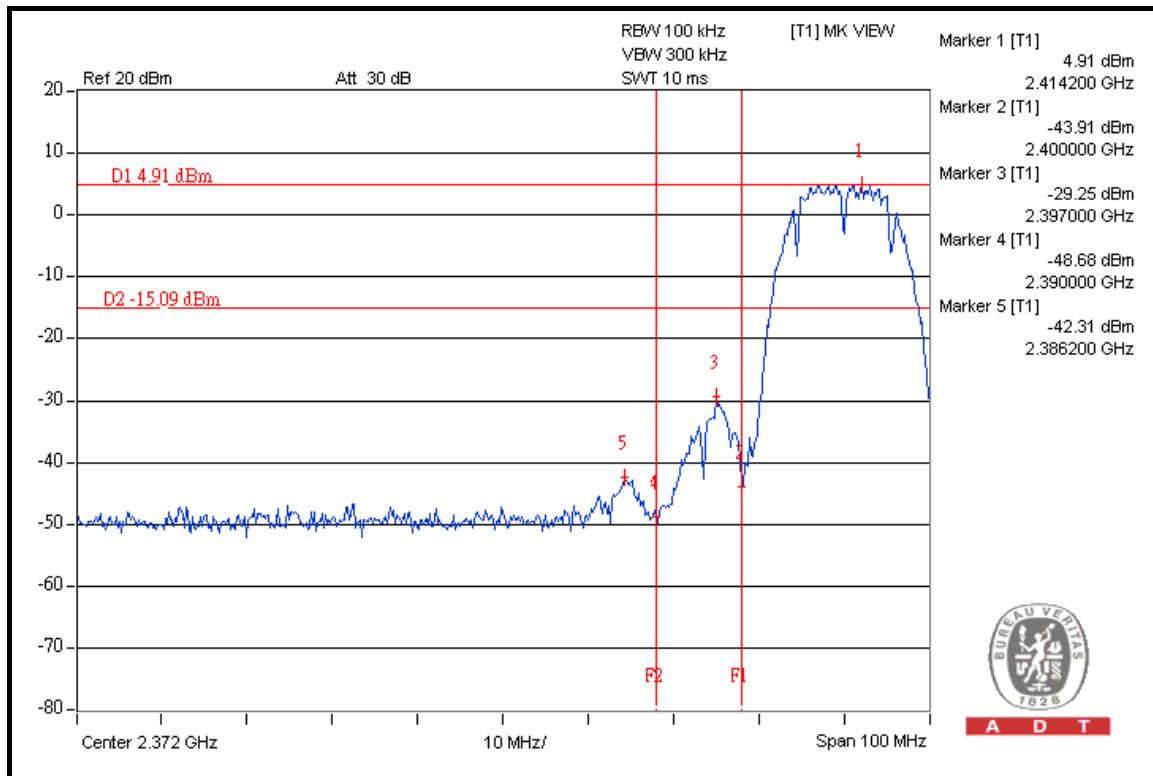



A D T

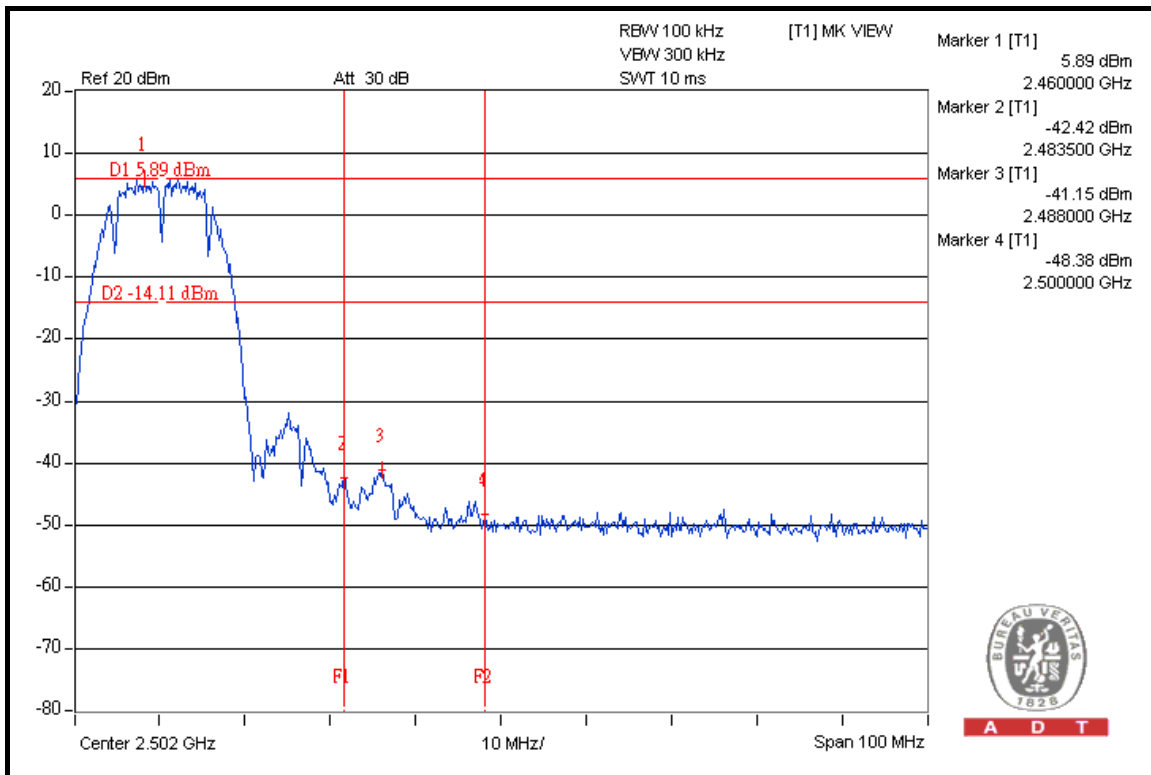
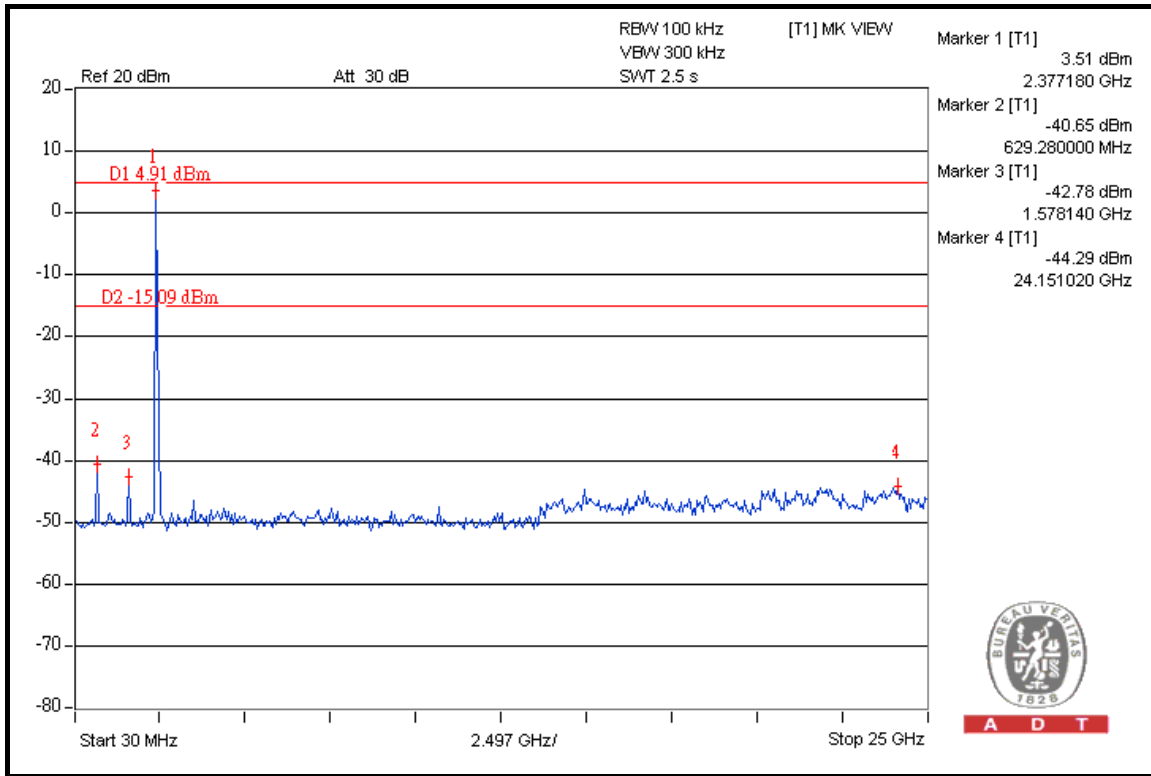



A D T

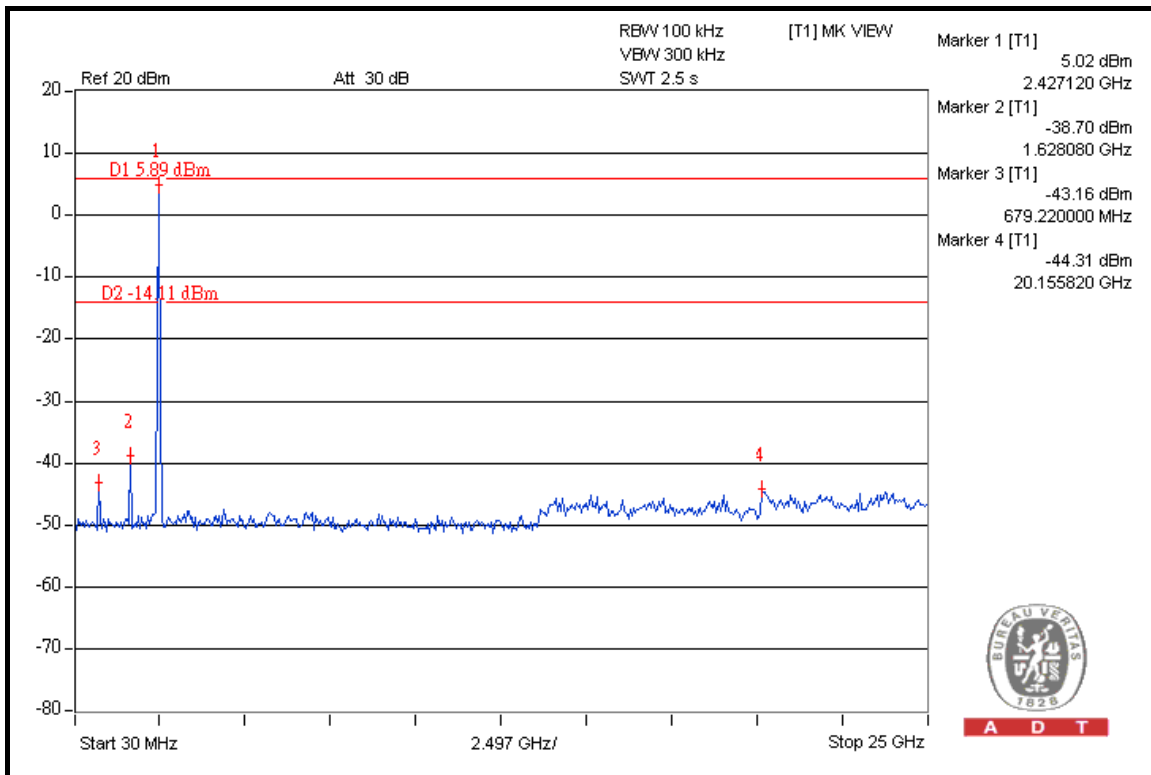
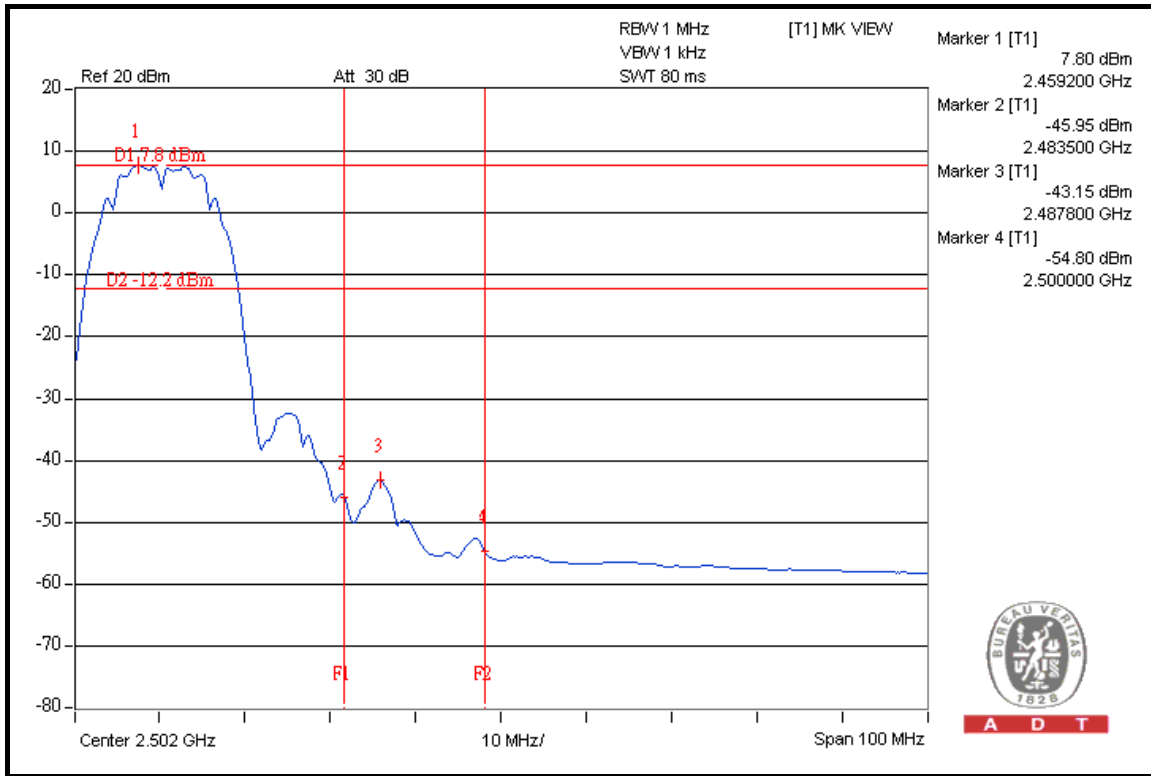

802.11g OFDM MODULATION: 1TX

NOTE 1: The band edge emission plot on the next page shows 42.22dBc between carrier maximum power and local maximum emission in restrict band (2.3892GHz). The emission of carrier strength list in the test result of channel 1 at the item 4.1.7 is 107.48dBuV/m (Peak), so the maximum field strength in restrict band is $107.48 - 42.22 = 65.26$ dBuV/m which is under 74dBuV/m limit.

The band edge emission plot on the next page shows 46.27dBc between carrier maximum power and local maximum emission in restrict band (2.3900GHz). The emission of carrier strength list in the test result of channel 1 at the item 4.1.7 is 97.22dBuV/m (Average), so the maximum field strength in restrict band is $97.22 - 46.27 = 50.95$ dBuV/m which is under 54dBuV/m limit.

NOTE 2: The band edge emission plot on the next second page shows 43.16dBc between carrier maximum power and local maximum emission in restrict band (2.4836GHz). The emission of carrier strength list in the test result of channel 11 at the item 4.1.7 is 107.84dBuV/m (Peak), so the maximum field strength in restrict band is $107.84 - 43.16 = 64.68$ dBuV/m which is under 74dBuV/m limit.

The band edge emission plot on the next third page shows 47.17dBc between carrier maximum power and local maximum emission in restrict band (2.4835GHz). The emission of carrier strength list in the test result of channel 11 at the item 4.1.7 is 97.64dBuV/m (Average), so the maximum field strength in restrict band is $97.64 - 47.17 = 50.47$ dBuV/m which is under 54dBuV/m limit.



A D T

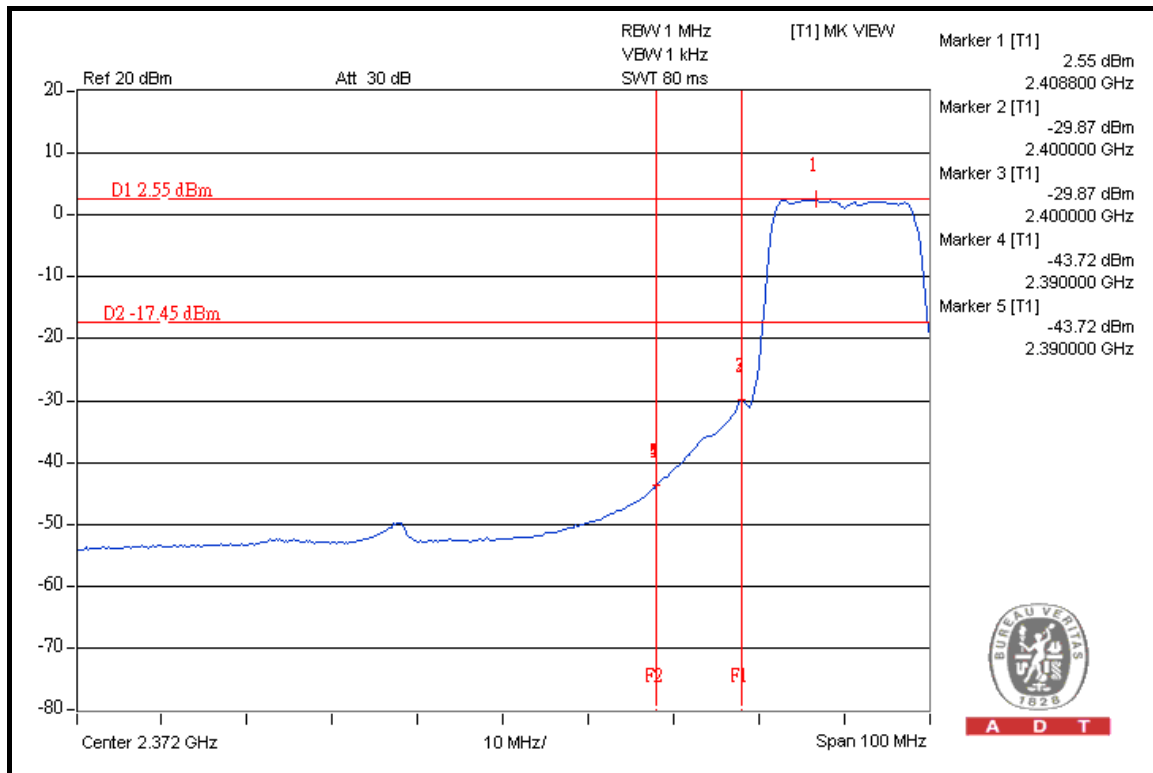
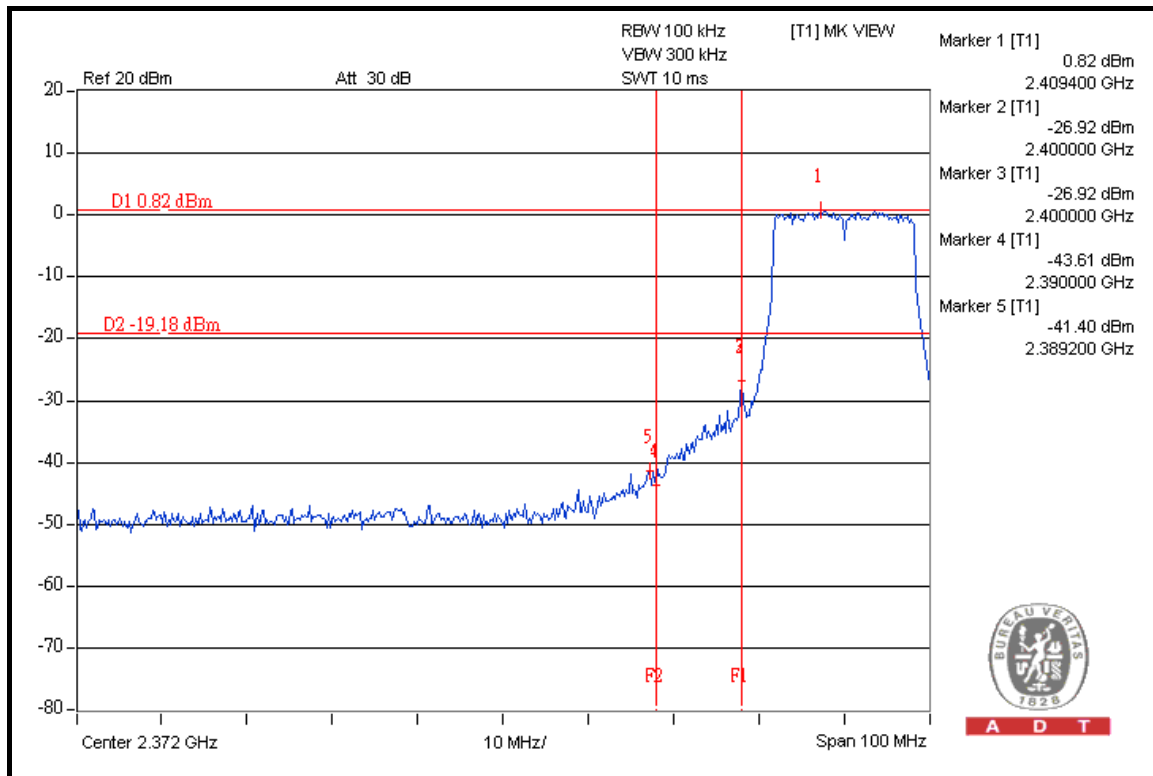



A D T

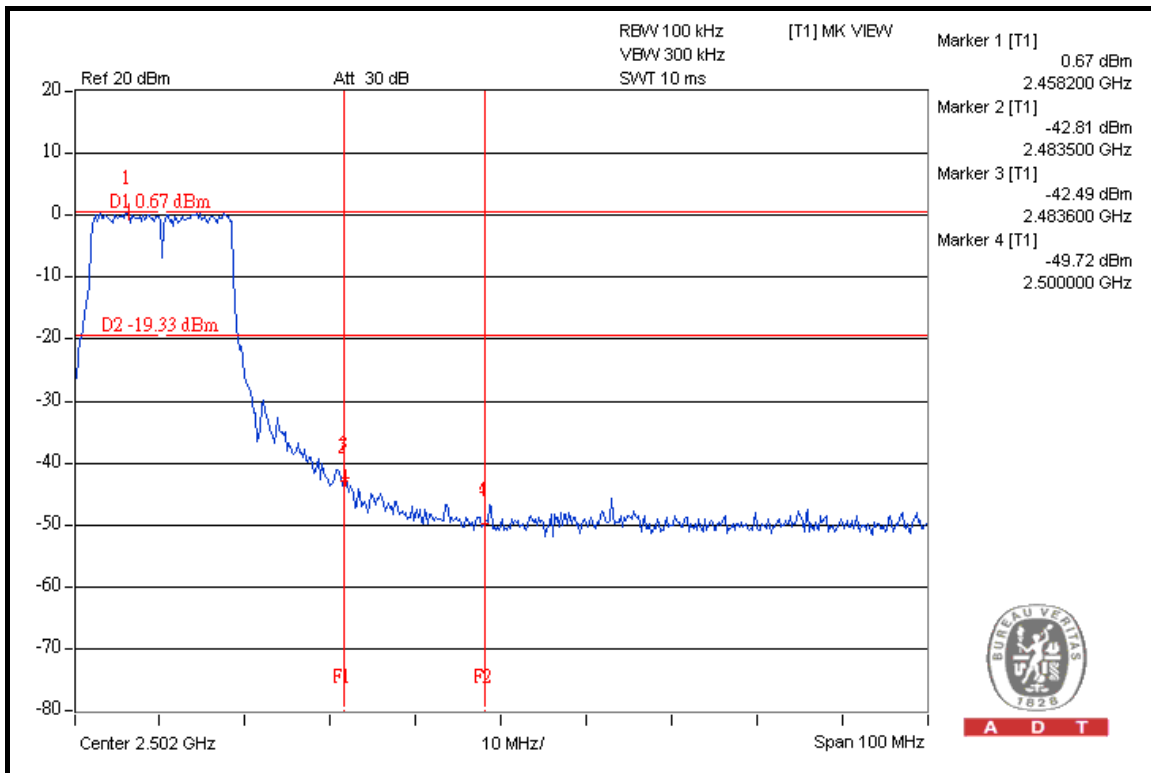
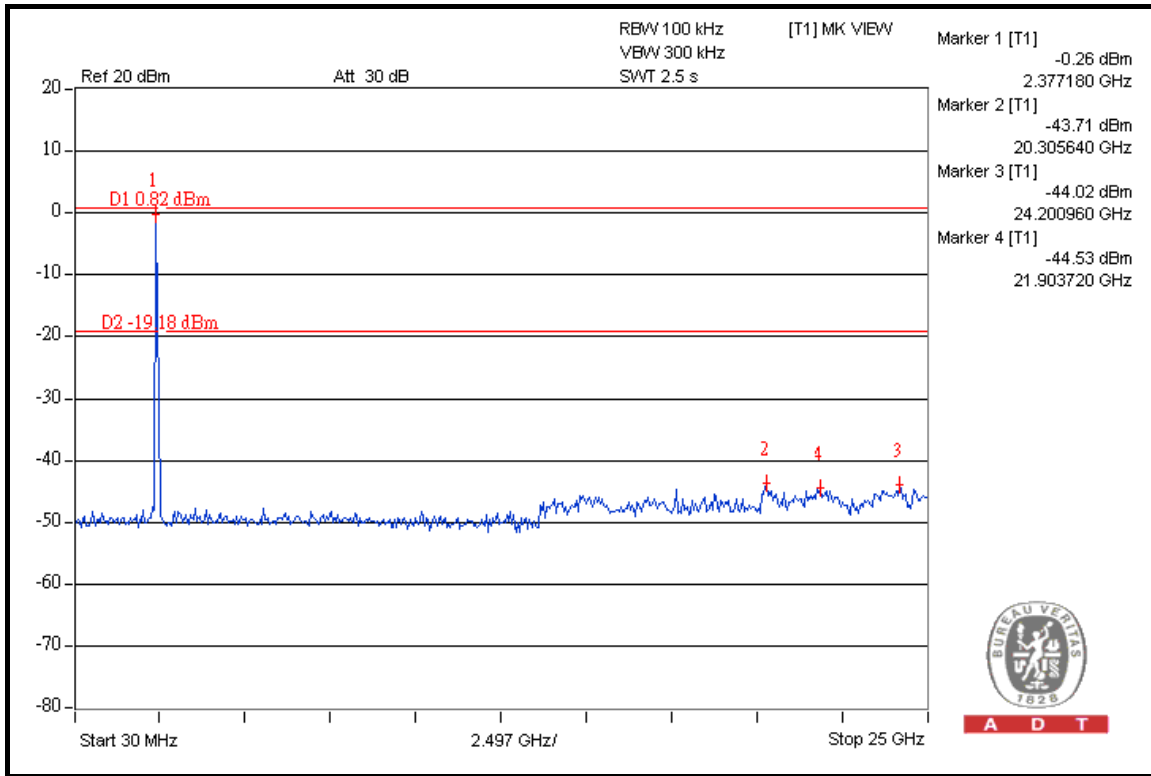



A D T

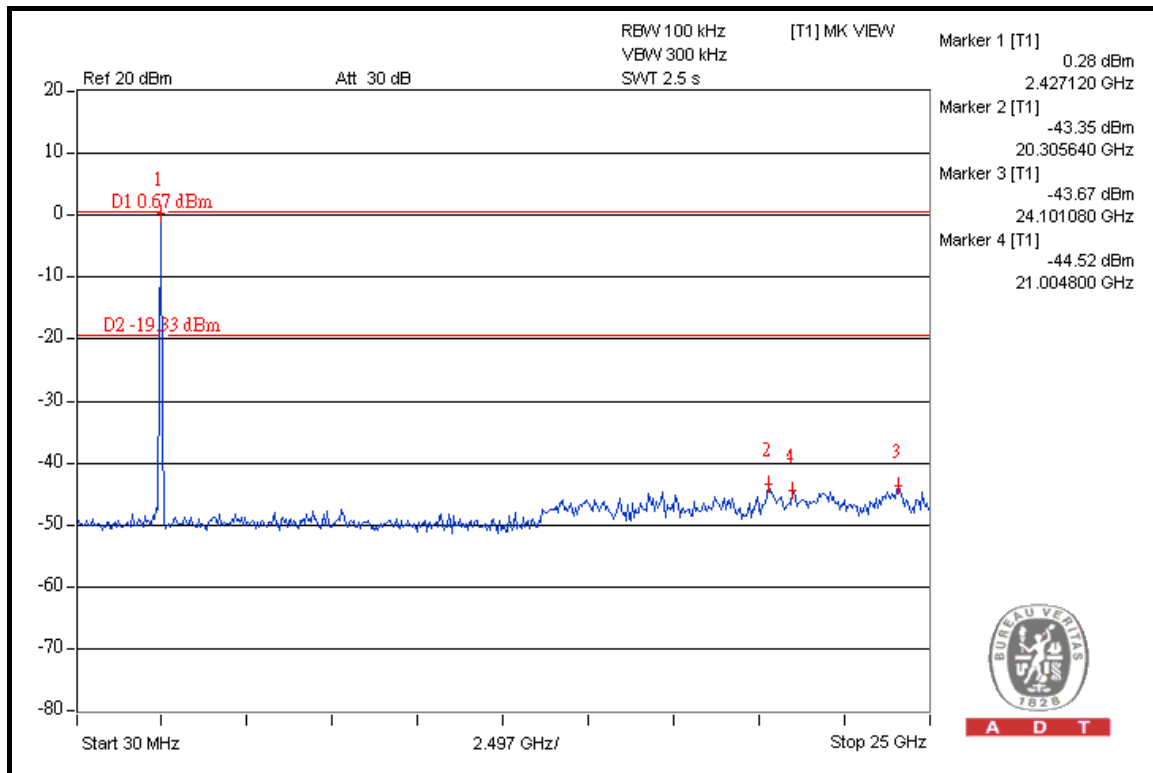
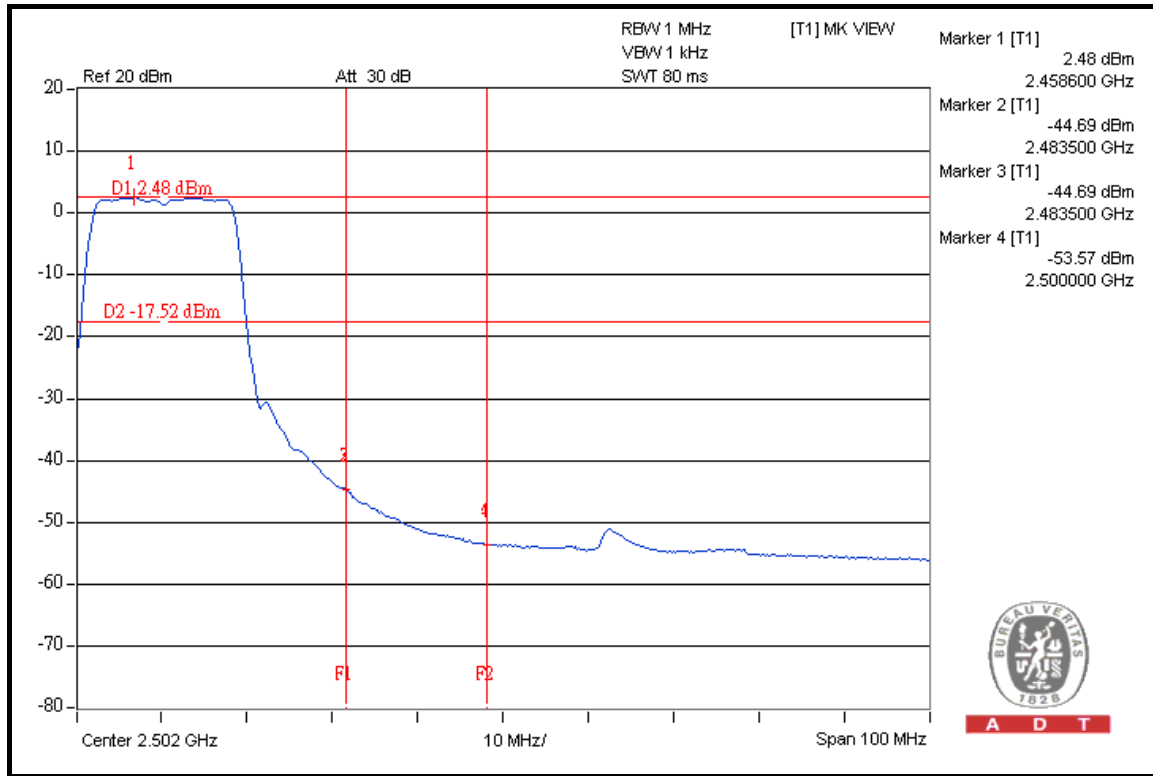

DRAFT 802.11n (20MHz) OFDM MODULATION: 1TX

NOTE 1: The band edge emission plot on the next page shows 37.46dBc between carrier maximum power and local maximum emission in restrict band (2.3880GHz). The emission of carrier strength list in the test result of channel 1 at the item 4.1.7 is 106.17dBuV/m (Peak), so the maximum field strength in restrict band is $106.17 - 37.46 = 68.71$ dBuV/m which is under 74dBuV/m limit.

The band edge emission plot on the next page shows 44.16dBc between carrier maximum power and local maximum emission in restrict band (2.3900GHz). The emission of carrier strength list in the test result of channel 1 at the item 4.1.7 is 96.97dBuV/m (Average), so the maximum field strength in restrict band is $96.97 - 44.16 = 52.81$ dBuV/m which is under 54dBuV/m limit.

NOTE 2: The band edge emission plot on the next second page shows 43.42dBc between carrier maximum power and local maximum emission in restrict band (2.4840GHz). The emission of carrier strength list in the test result of channel 11 at the item 4.1.7 is 106.02dBuV/m (Peak), so the maximum field strength in restrict band is $106.02 - 43.42 = 62.60$ dBuV/m which is under 74dBuV/m limit.

The band edge emission plot on the next third page shows 46.20dBc between carrier maximum power and local maximum emission in restrict band (2.4835GHz). The emission of carrier strength list in the test result of channel 11 at the item 4.1.7 is 96.62dBuV/m (Average), so the maximum field strength in restrict band is $96.62 - 46.20 = 50.42$ dBuV/m which is under 54dBuV/m limit.



A D T

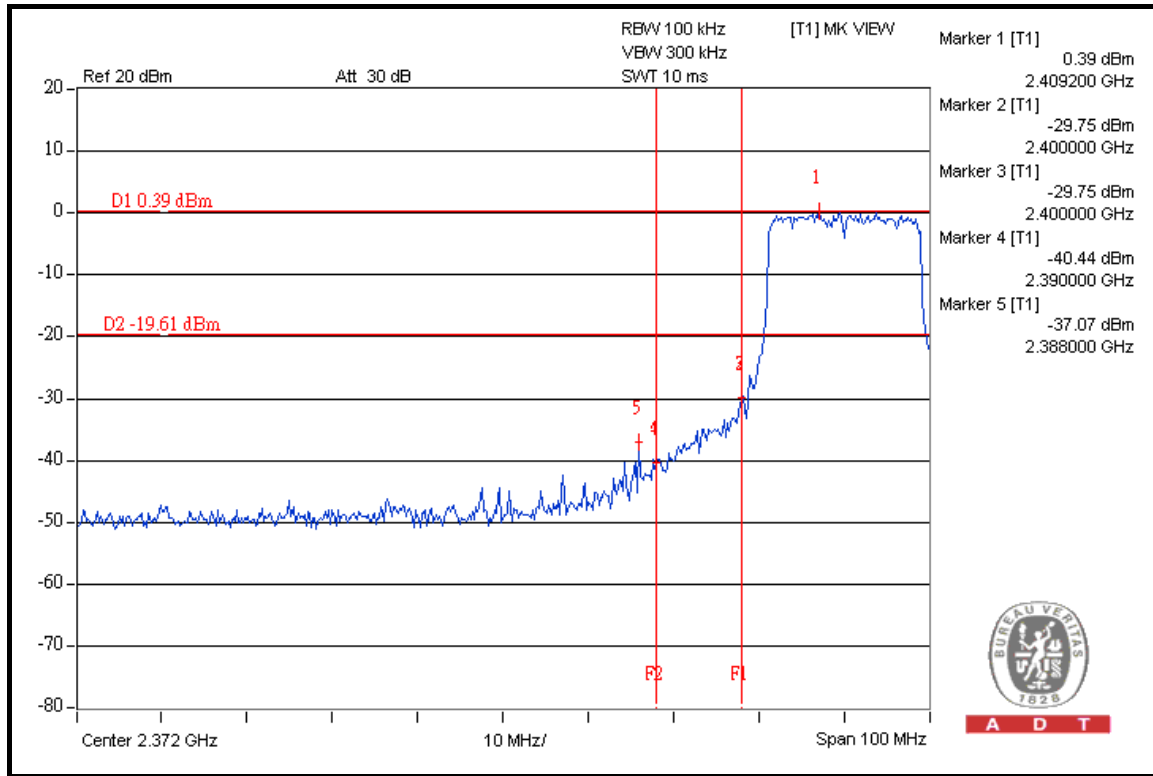

A D T

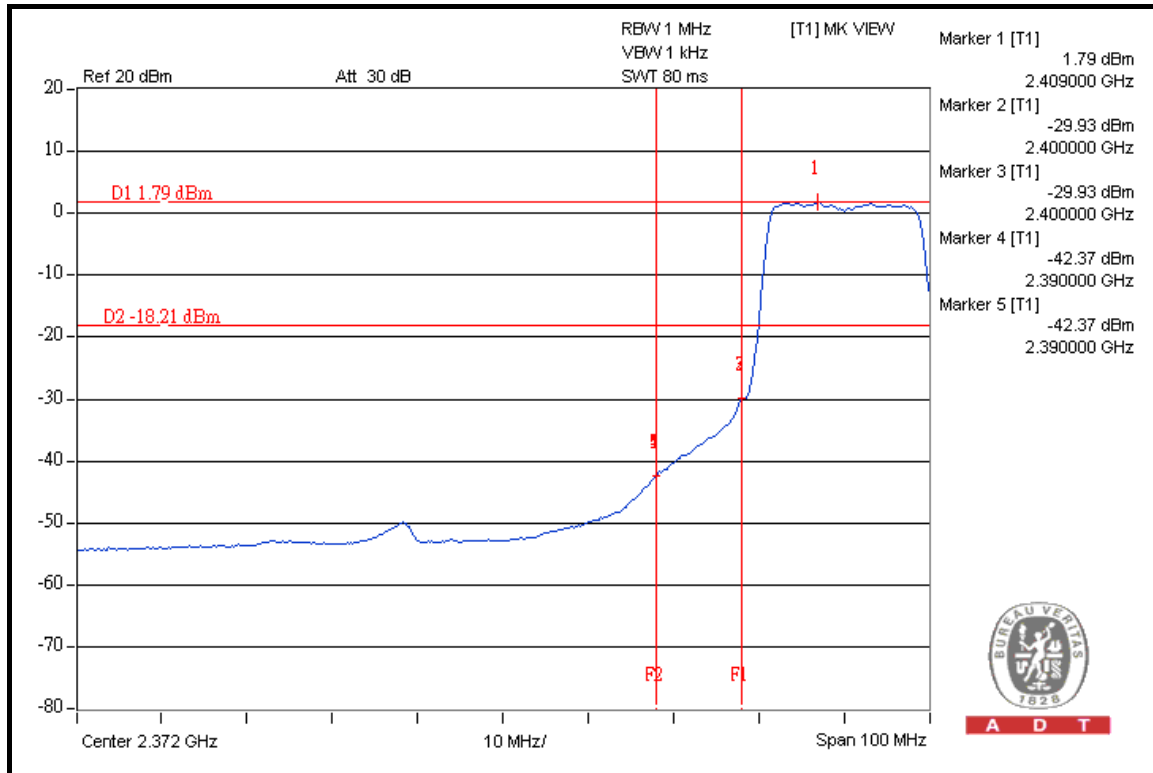

A D T



A D T

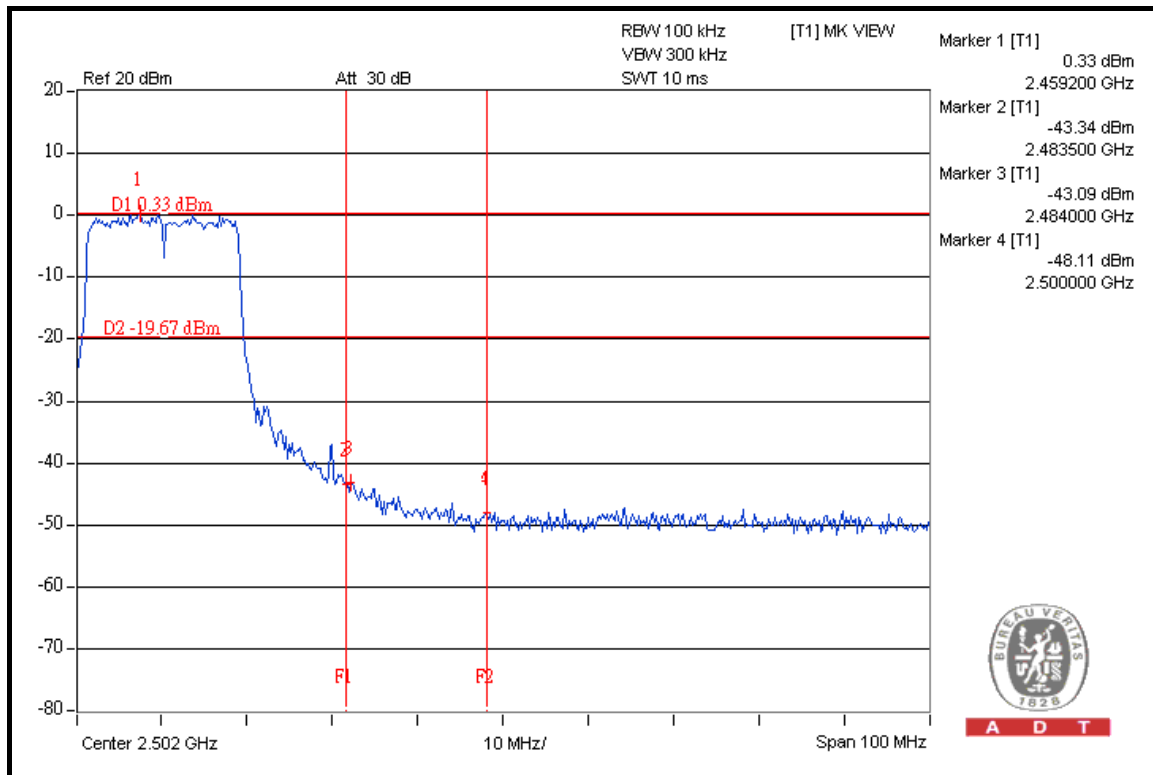
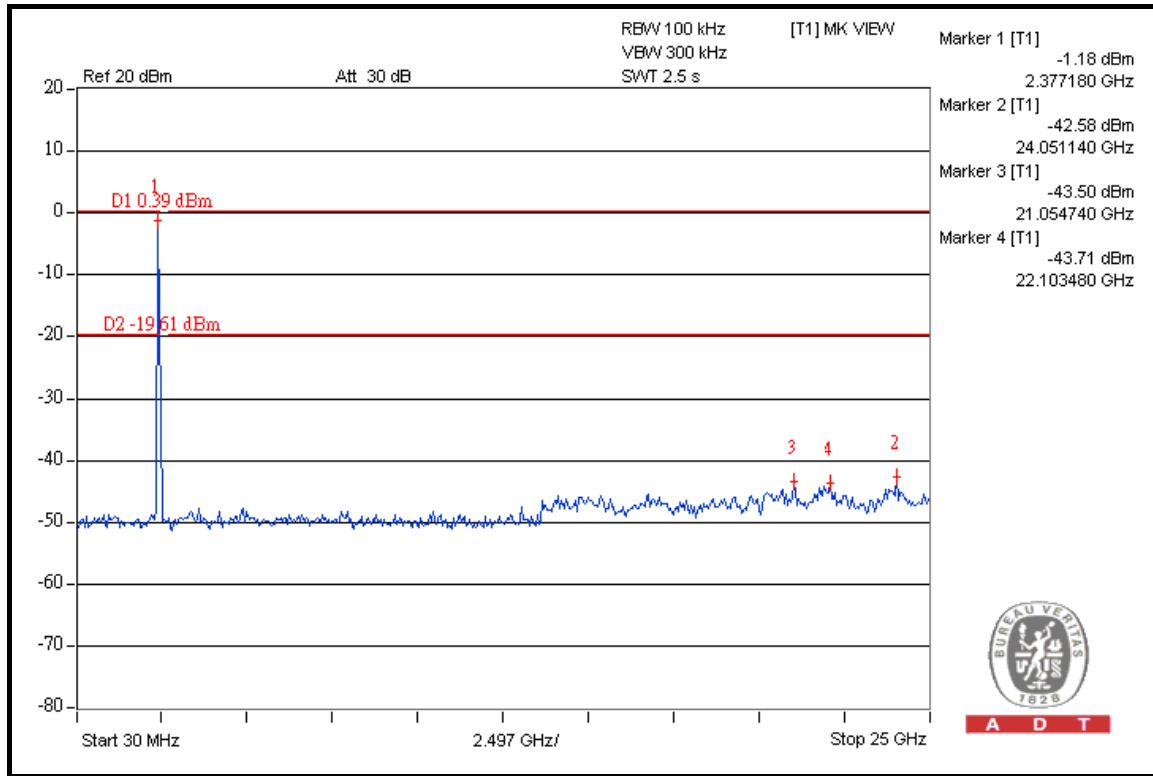



A D T

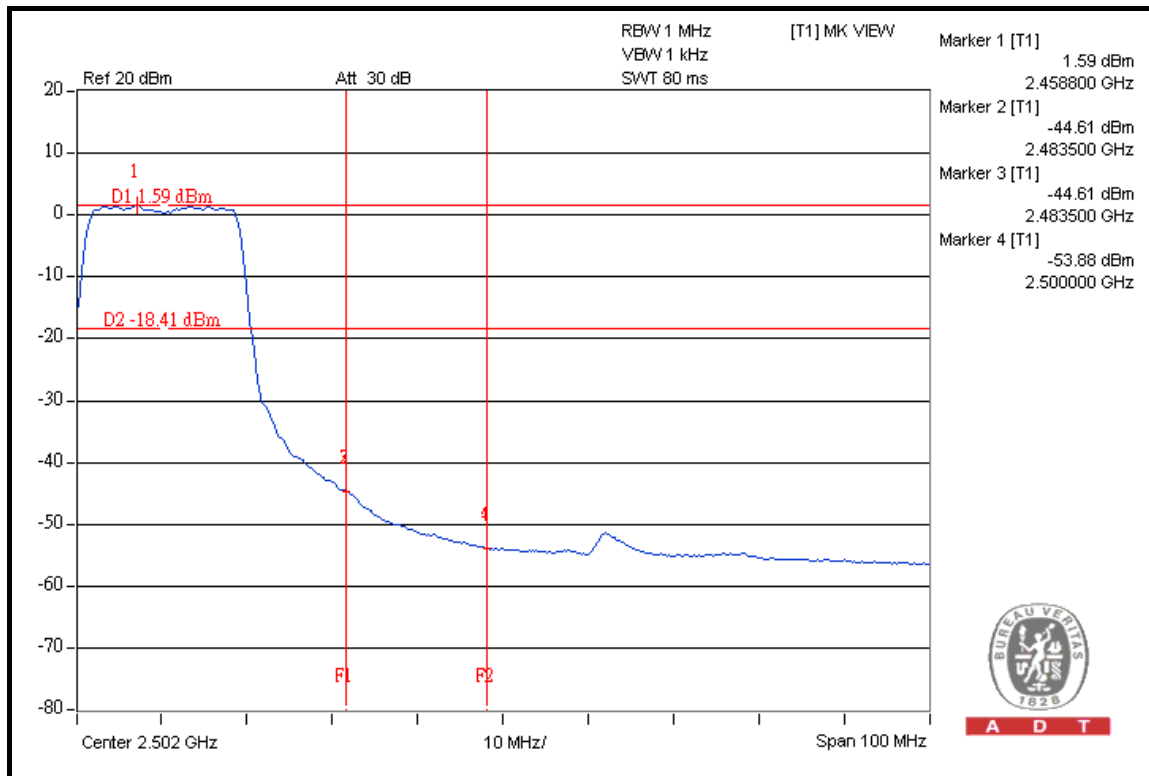

A D T

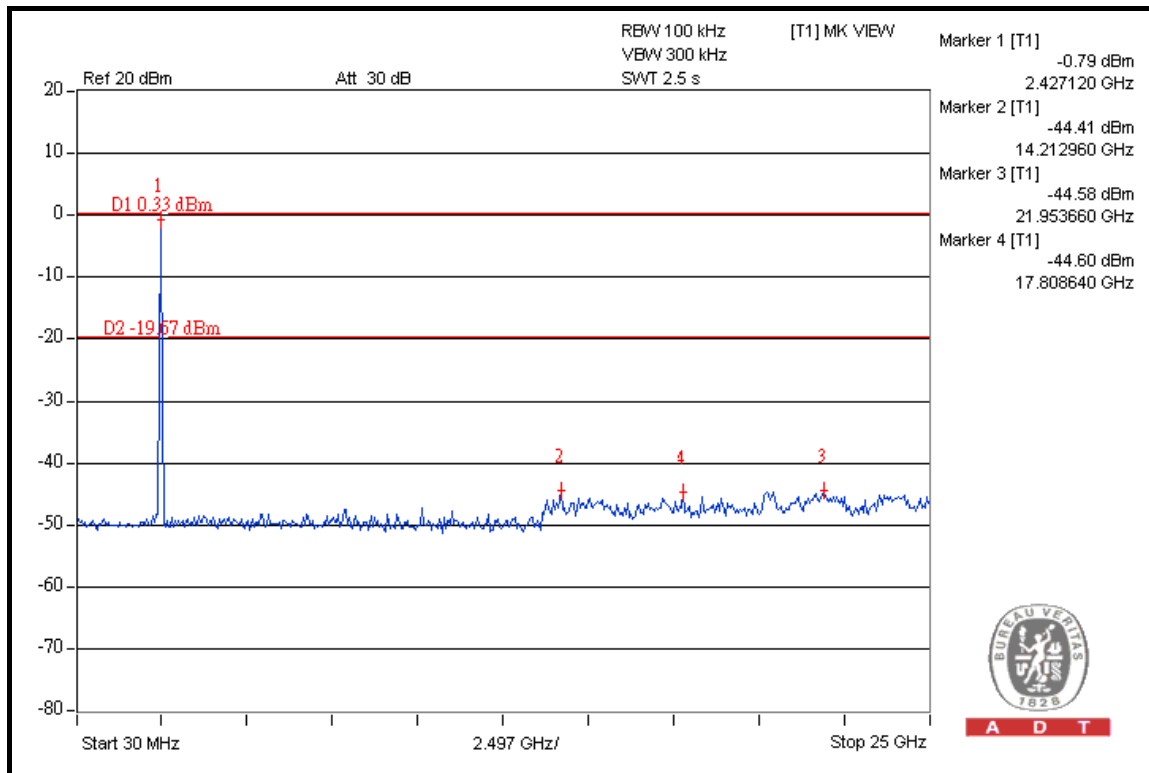

A D T

DRAFT 802.11n (20MHz) OFDM MODULATION: 2TX

NOTE 1: The band edge emission plot on the next page shows 43.12dBc between carrier maximum power and local maximum emission in restrict band (2.3900GHz). The emission of carrier strength list in the test result of channel 1 at the item 4.1.7 is 109.15dBuV/m (Peak), so the maximum field strength in restrict band is $109.15 - 43.12 = 66.03$ dBuV/m which is under 74dBuV/m limit.

The band edge emission plot on the next page shows 47.57dBc between carrier maximum power and local maximum emission in restrict band (2.3900GHz). The emission of carrier strength list in the test result of channel 1 at the item 4.1.7 is 99.29dBuV/m (Average), so the maximum field strength in restrict band is $99.29 - 47.57 = 51.72$ dBuV/m which is under 54dBuV/m limit.

NOTE 2: The band edge emission plot on the next second page shows 42.77dBc between carrier maximum power and local maximum emission in restrict band (2.4842GHz). The emission of carrier strength list in the test result of channel 11 at the item 4.1.7 is 108.17dBuV/m (Peak), so the maximum field strength in restrict band is $108.17 - 42.77 = 65.40$ dBuV/m which is under 74dBuV/m limit.

The band edge emission plot on the next third page shows 45.25dBc between carrier maximum power and local maximum emission in restrict band (2.4835GHz). The emission of carrier strength list in the test result of channel 11 at the item 4.1.7 is 98.21dBuV/m (Average), so the maximum field strength in restrict band is $98.21 - 45.25 = 52.96$ dBuV/m which is under 54dBuV/m limit.



A D T

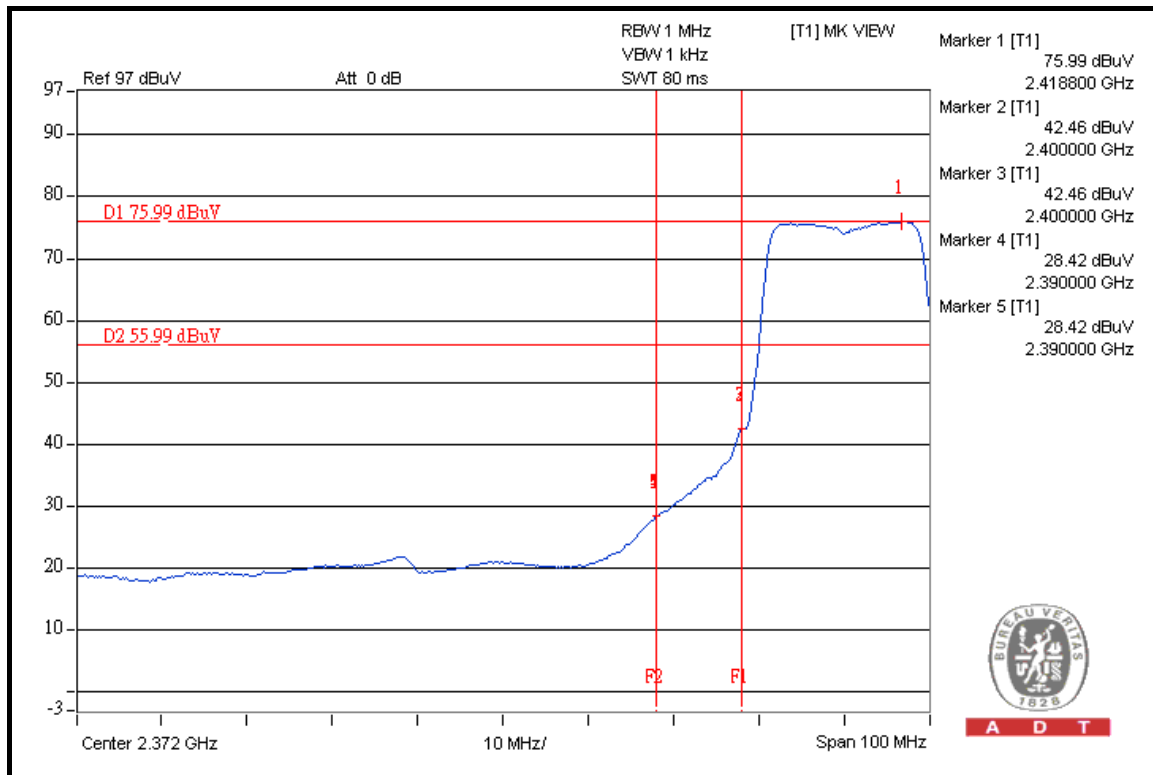
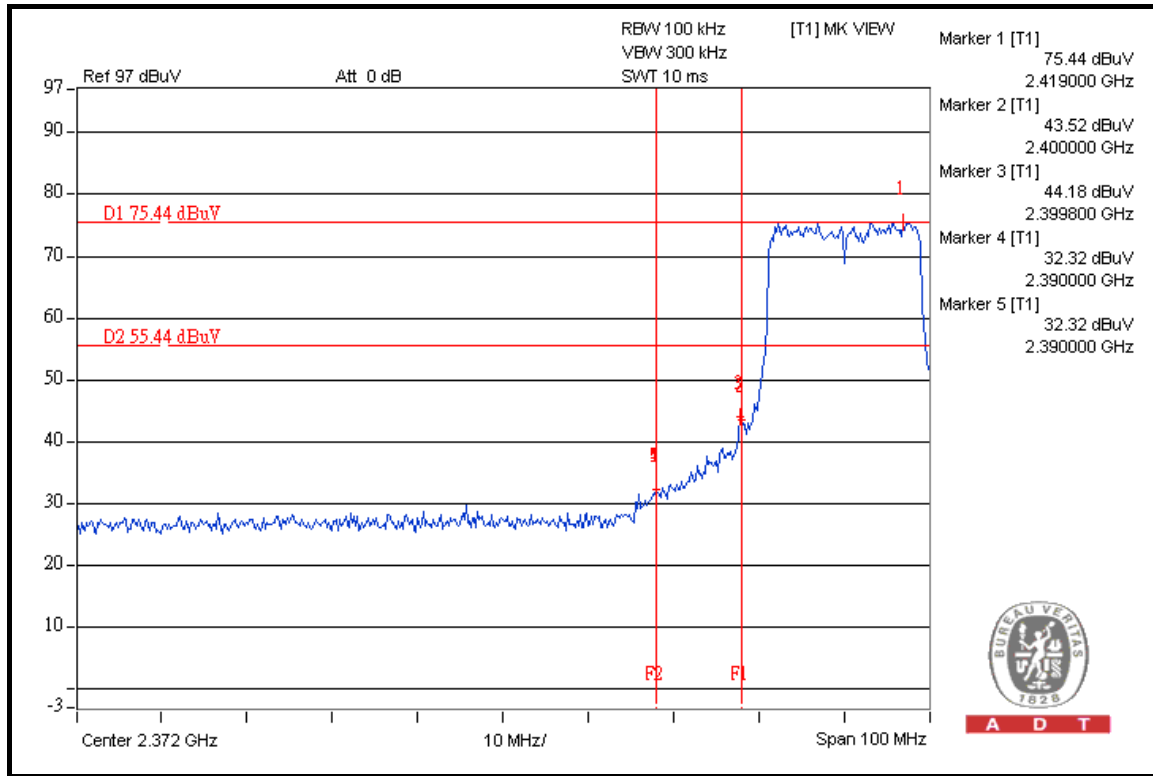



A D T

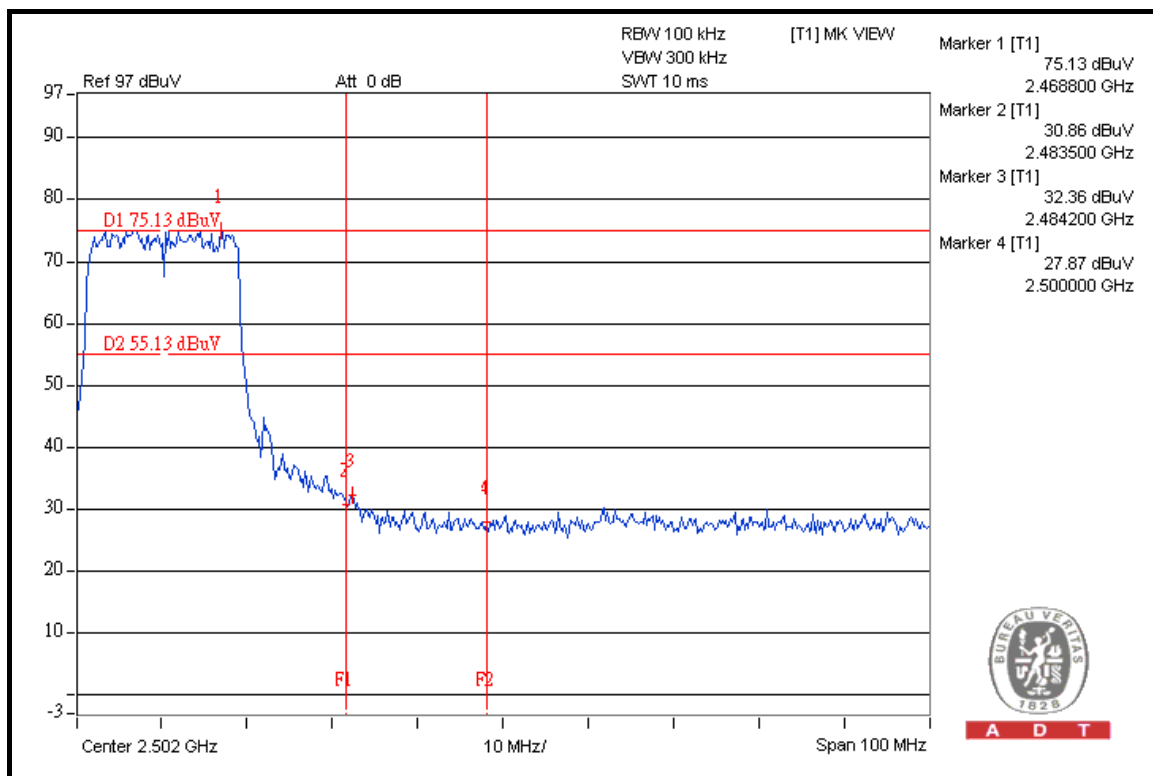
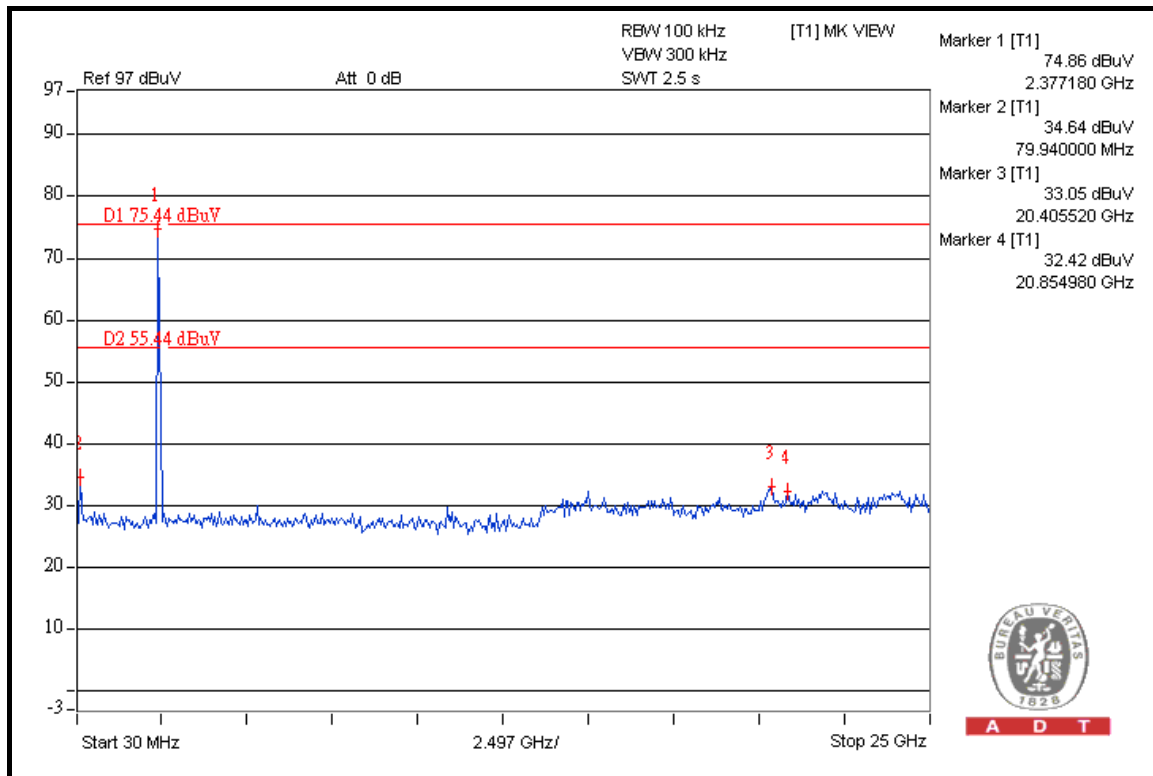



A D T

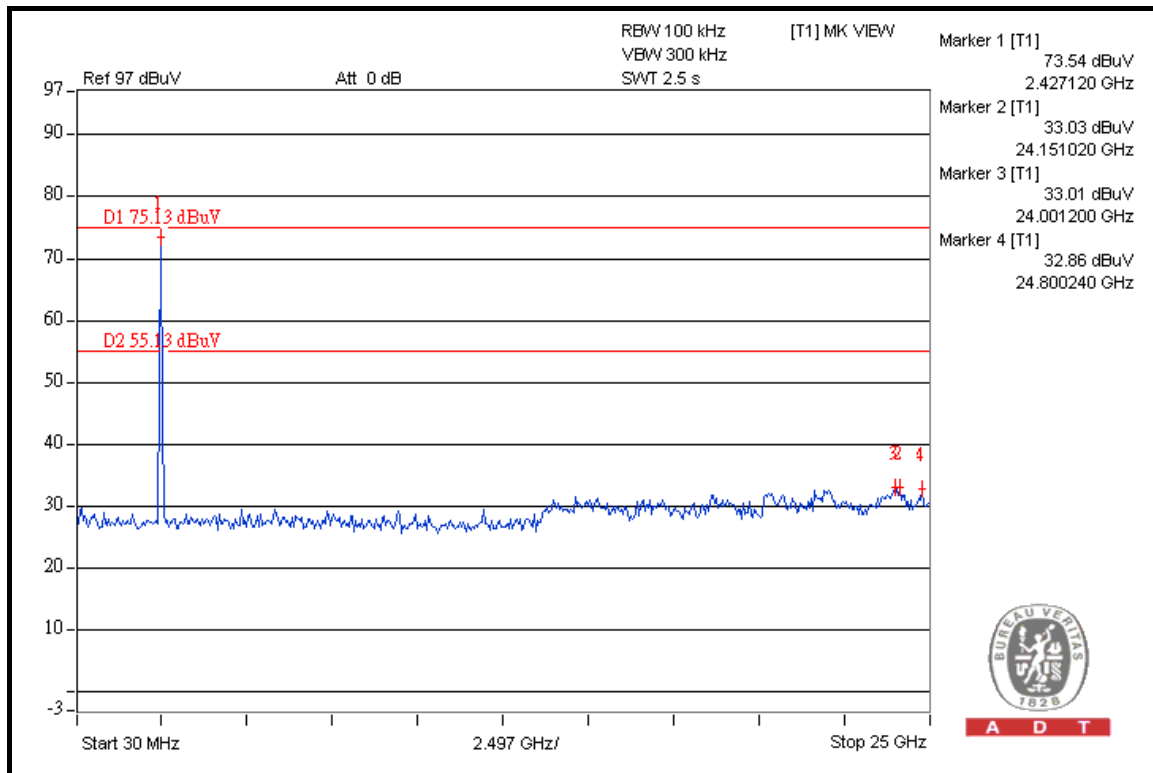
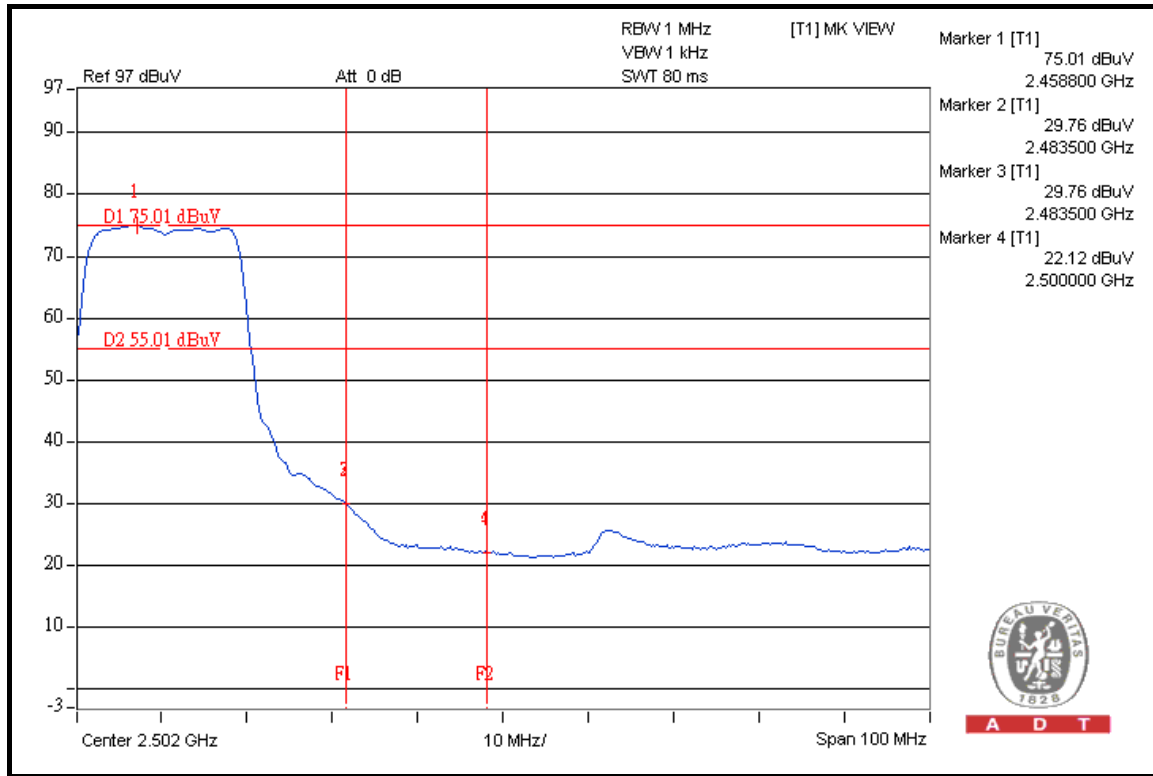

DRAFT 802.11n (40MHz) OFDM MODULATION: 1TX

NOTE 1: The band edge emission plot on the next page shows 32.77dBc between carrier maximum power and local maximum emission in restrict band (2.3892GHz). The emission of carrier strength list in the test result of channel 1 at the item 4.1.7 is 103.69dBuV/m (Peak), so the maximum field strength in restrict band is $103.69 - 32.77 = 70.92$ dBuV/m which is under 74dBuV/m limit.

The band edge emission plot on the next page shows 42.08dBc between carrier maximum power and local maximum emission in restrict band (2.3900GHz). The emission of carrier strength list in the test result of channel 1 at the item 4.1.7 is 94.39dBuV/m (Average), so the maximum field strength in restrict band is $94.39 - 42.08 = 52.31$ dBuV/m which is under 54dBuV/m limit.

NOTE 2: The band edge emission plot on the next second page shows 38.71dBc between carrier maximum power and local maximum emission in restrict band (2.4836GHz). The emission of carrier strength list in the test result of channel 7 at the item 4.1.7 is 103.74dBuV/m (Peak), so the maximum field strength in restrict band is $103.74 - 38.71 = 65.03$ dBuV/m which is under 74dBuV/m limit.

The band edge emission plot on the next third page shows 41.53dBc between carrier maximum power and local maximum emission in restrict band (2.4836GHz). The emission of carrier strength list in the test result of channel 7 at the item 4.1.7 is 94.48dBuV/m (Average), so the maximum field strength in restrict band is $94.48 - 41.53 = 52.95$ dBuV/m which is under 54dBuV/m limit.



A D T

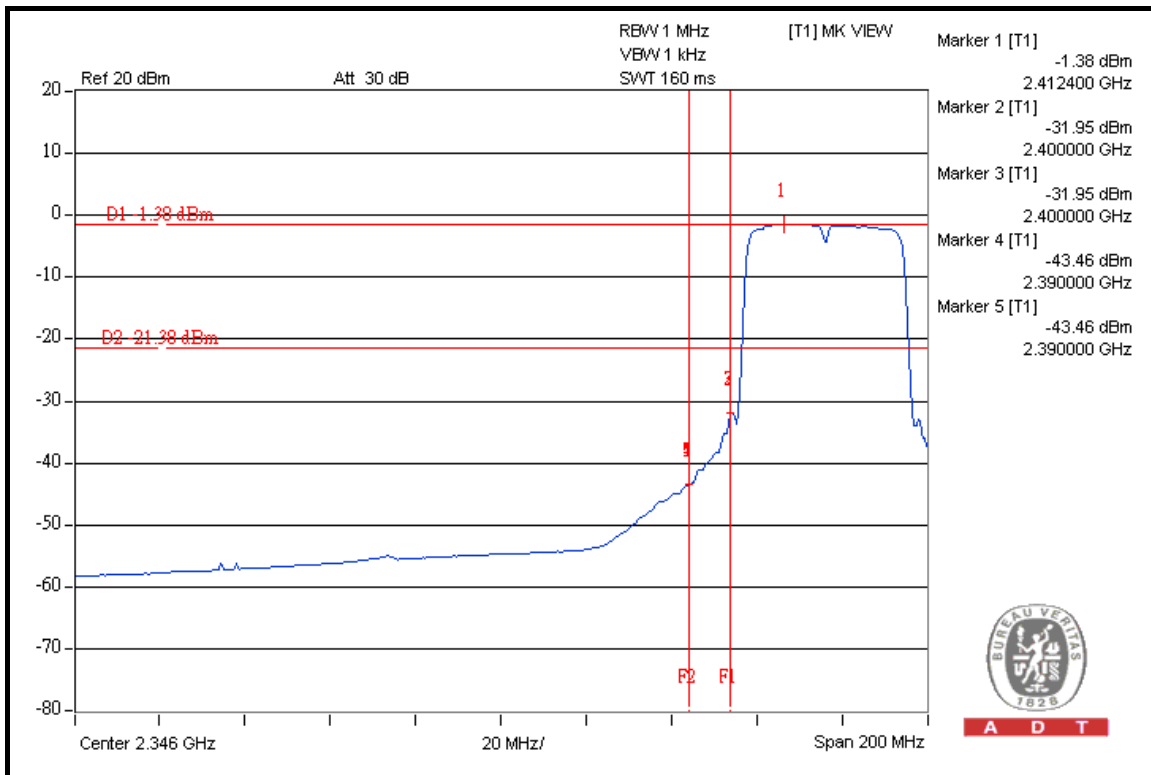
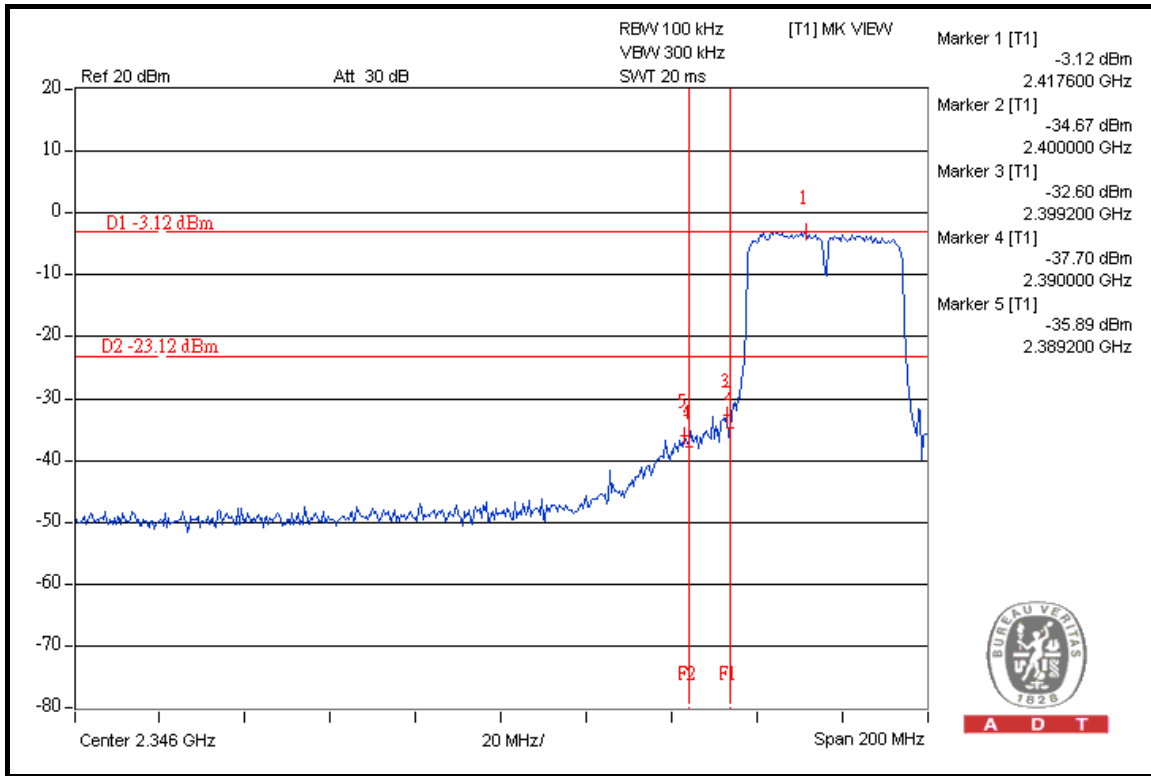



A D T

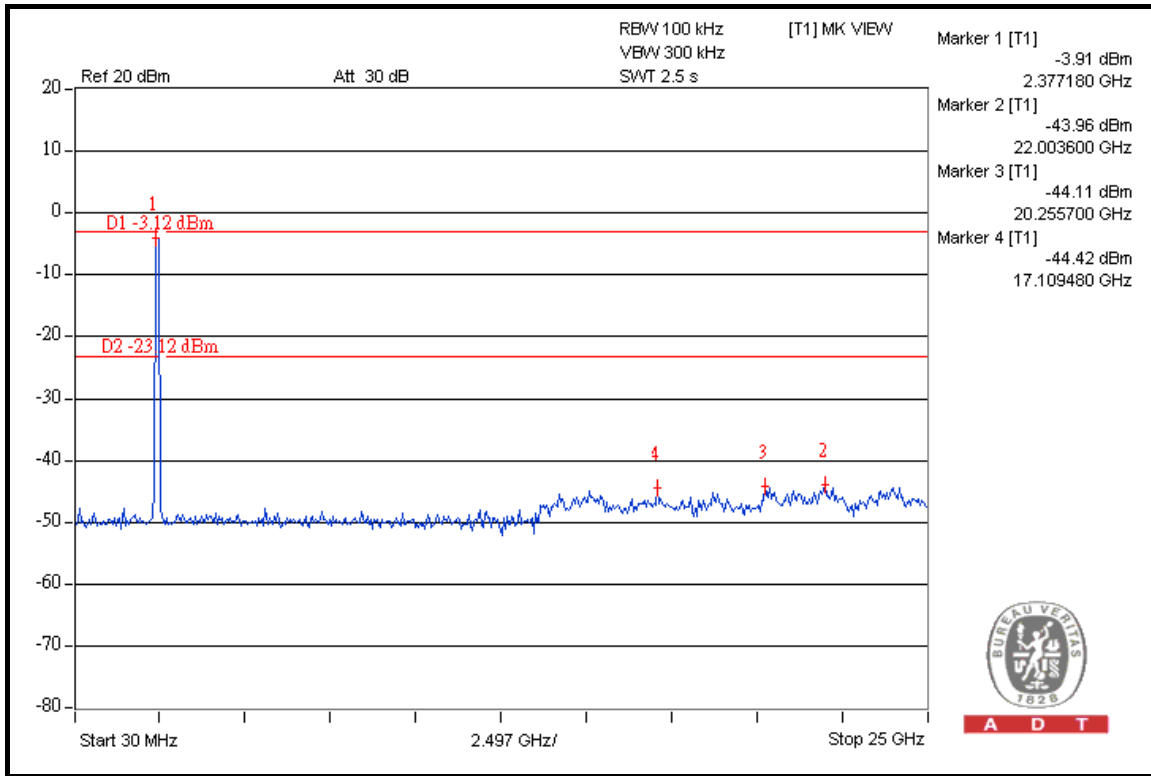

A D T

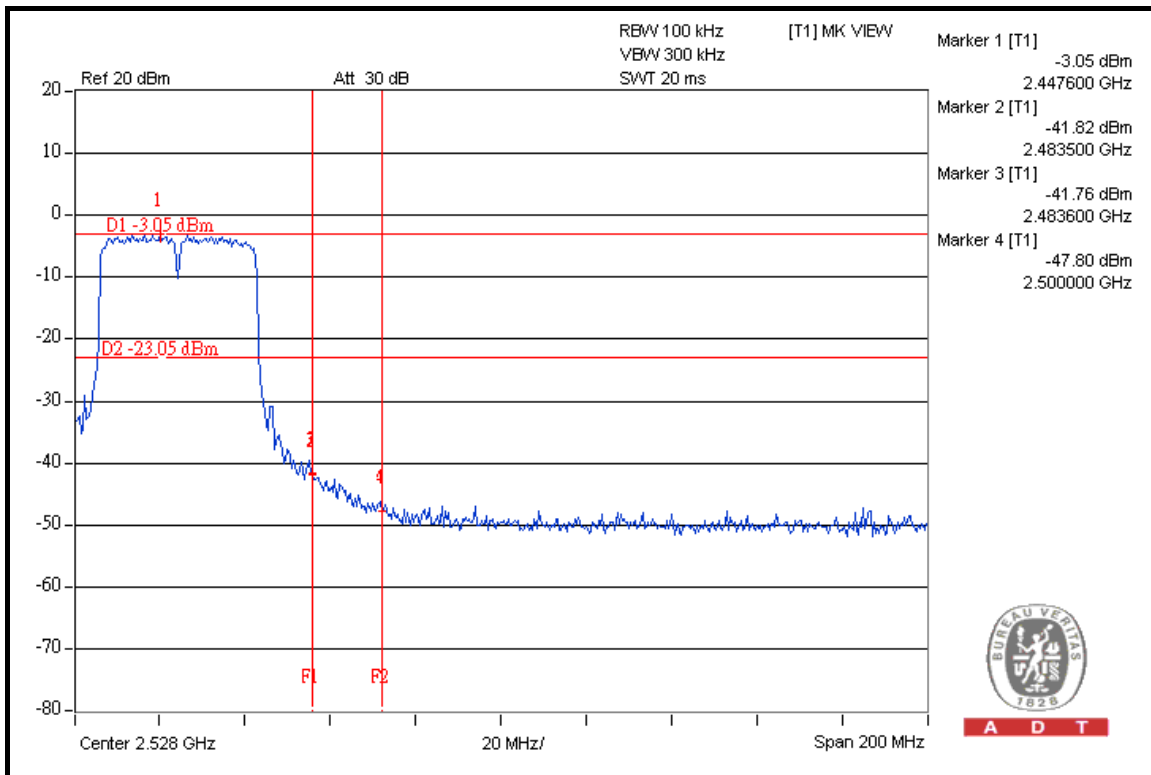

A D T



A D T

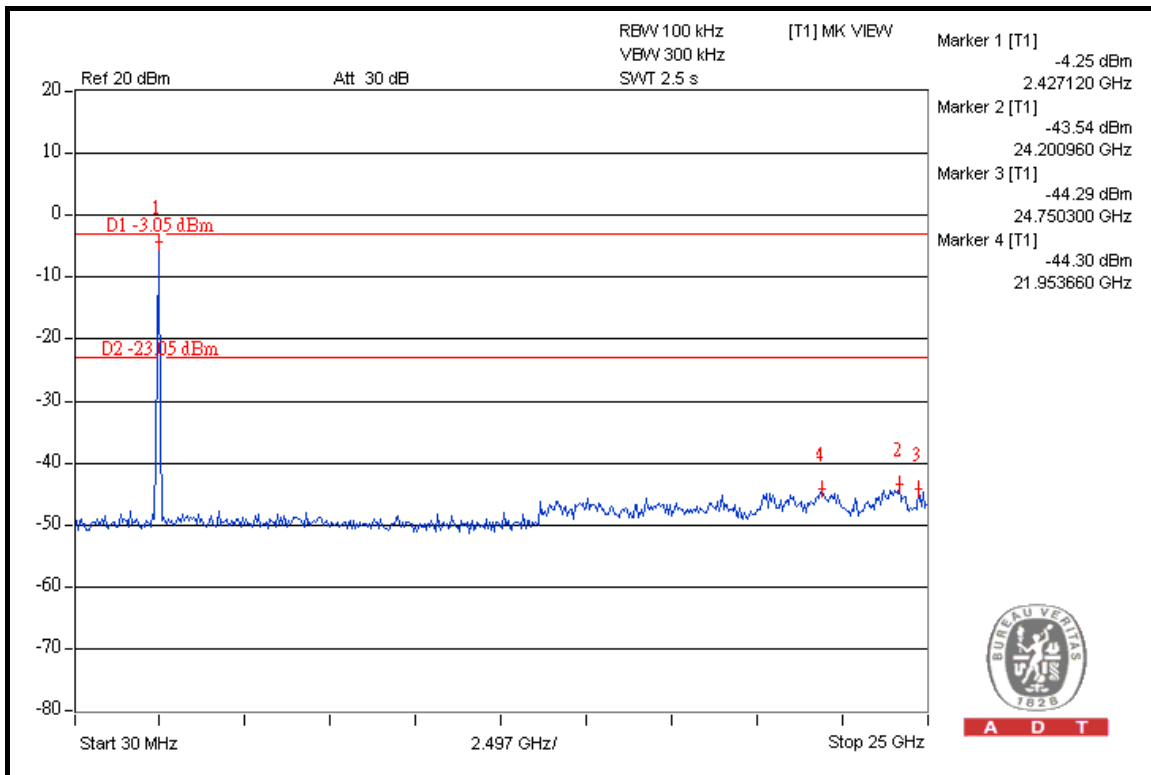
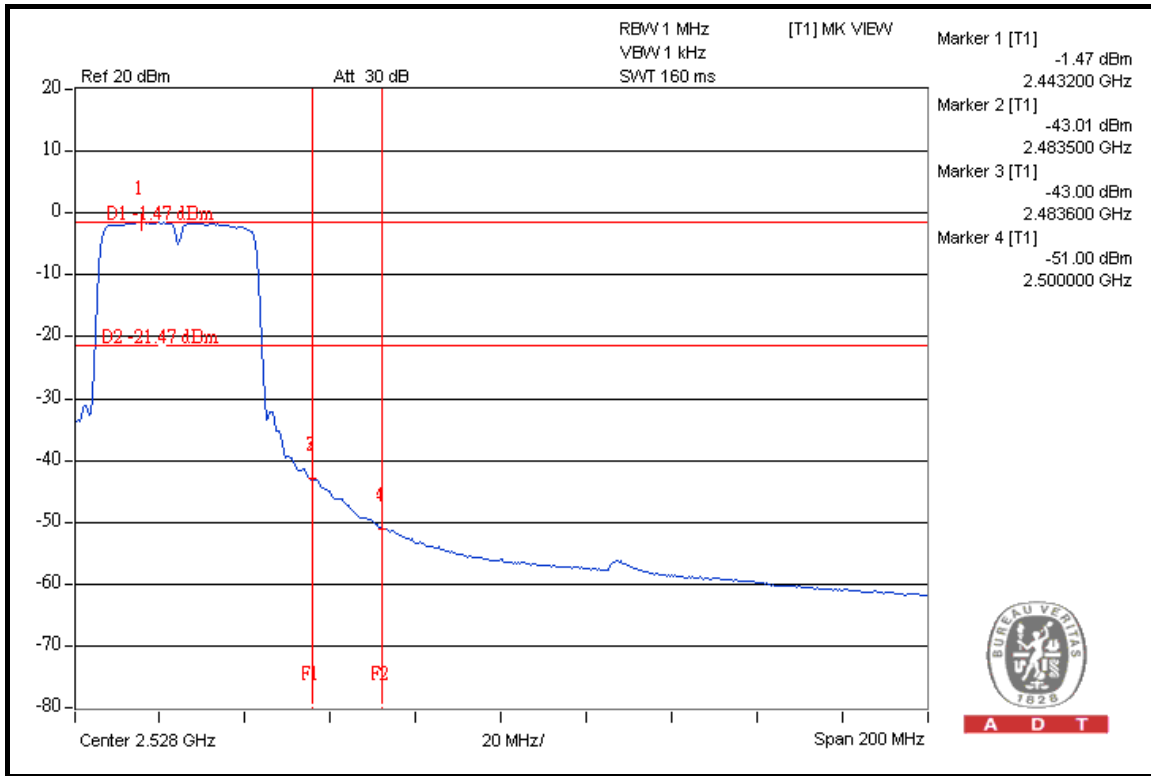

DRAFT 802.11n (40MHz) OFDM MODULATION: 2TX

NOTE 1: The band edge emission plot on the next page shows 42.09dBc between carrier maximum power and local maximum emission in restrict band (2.3900GHz). The emission of carrier strength list in the test result of channel 1 at the item 4.1.7 is 105.52dBuV/m (Peak), so the maximum field strength in restrict band is $105.52 - 42.09 = 63.43$ dBuV/m which is under 74dBuV/m limit.

The band edge emission plot on the next page shows 46.08dBc between carrier maximum power and local maximum emission in restrict band (2.3900GHz). The emission of carrier strength list in the test result of channel 1 at the item 4.1.7 is 95.64dBuV/m (Average), so the maximum field strength in restrict band is $95.64 - 46.08 = 49.56$ dBuV/m which is under 54dBuV/m limit.

NOTE 2: The band edge emission plot on the next second page shows 39.05dBc between carrier maximum power and local maximum emission in restrict band (2.4836GHz). The emission of carrier strength list in the test result of channel 7 at the item 4.1.7 is 105.62dBuV/m (Peak), so the maximum field strength in restrict band is $105.62 - 39.05 = 66.57$ dBuV/m which is under 74dBuV/m limit.

The band edge emission plot on the next third page shows 42.69dBc between carrier maximum power and local maximum emission in restrict band (2.4840GHz). The emission of carrier strength list in the test result of channel 7 at the item 4.1.7 is 95.58dBuV/m (Average), so the maximum field strength in restrict band is $95.58 - 42.69 = 52.89$ dBuV/m which is under 54dBuV/m limit.



A D T

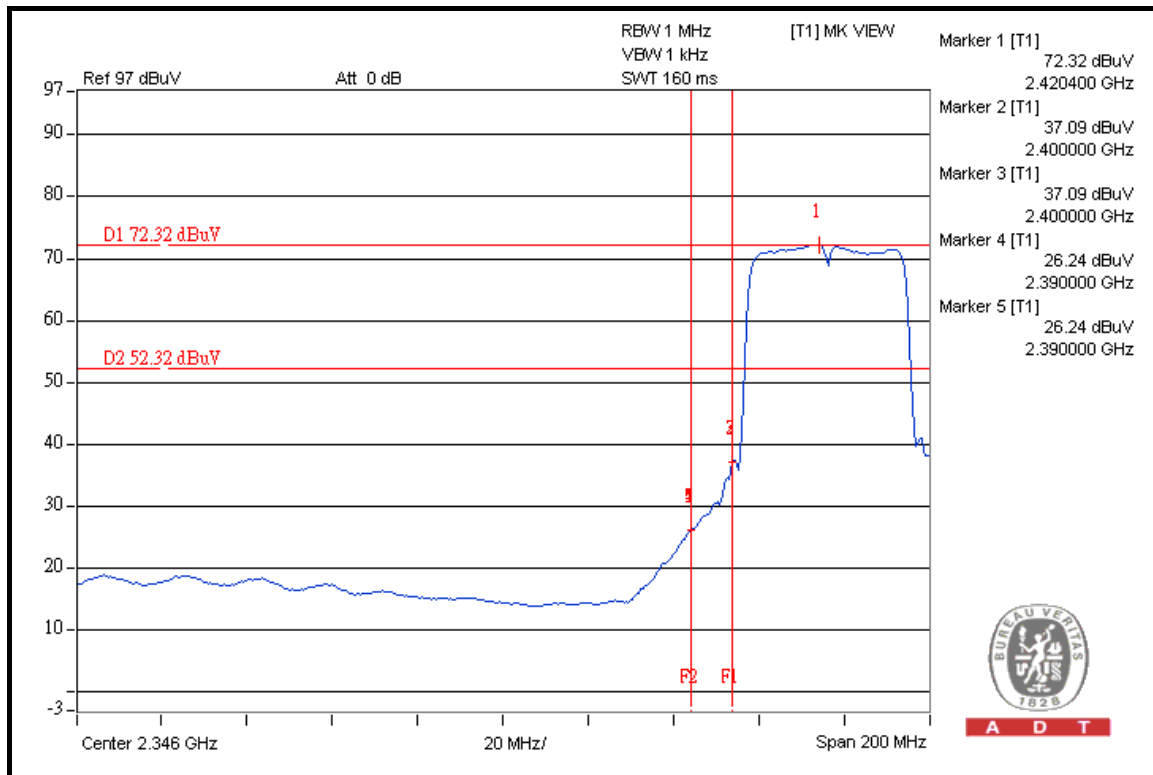
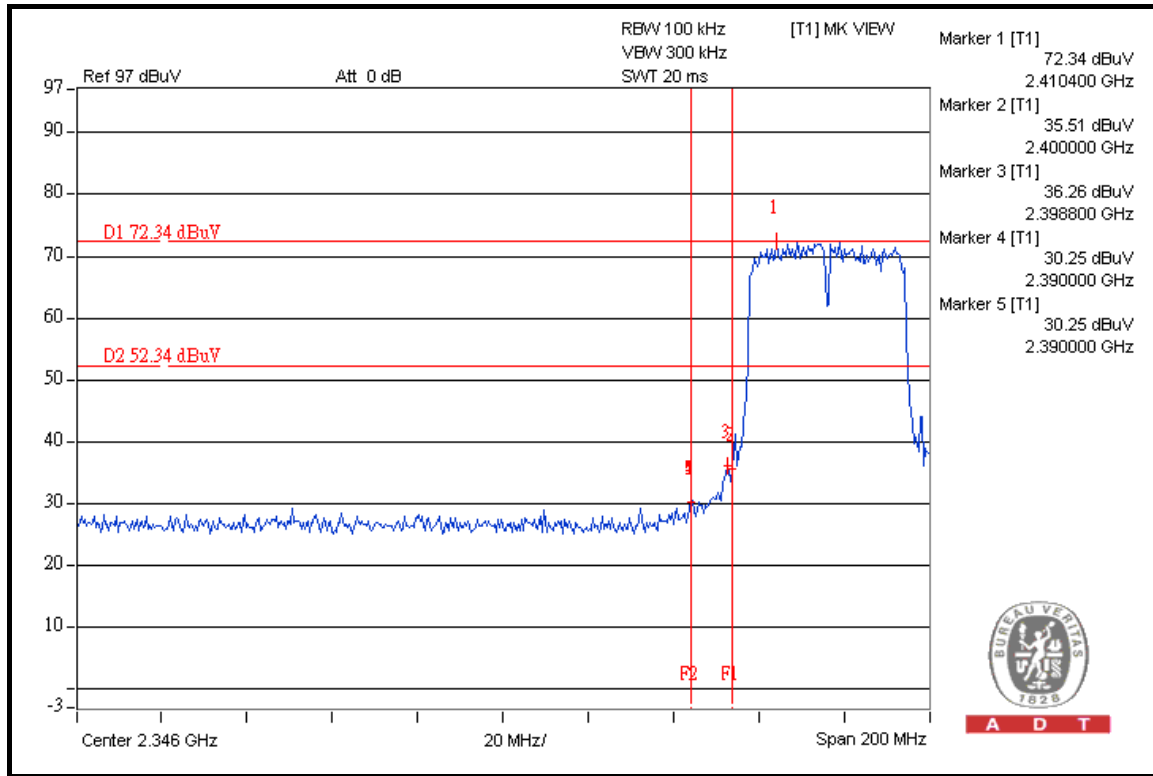



A D T

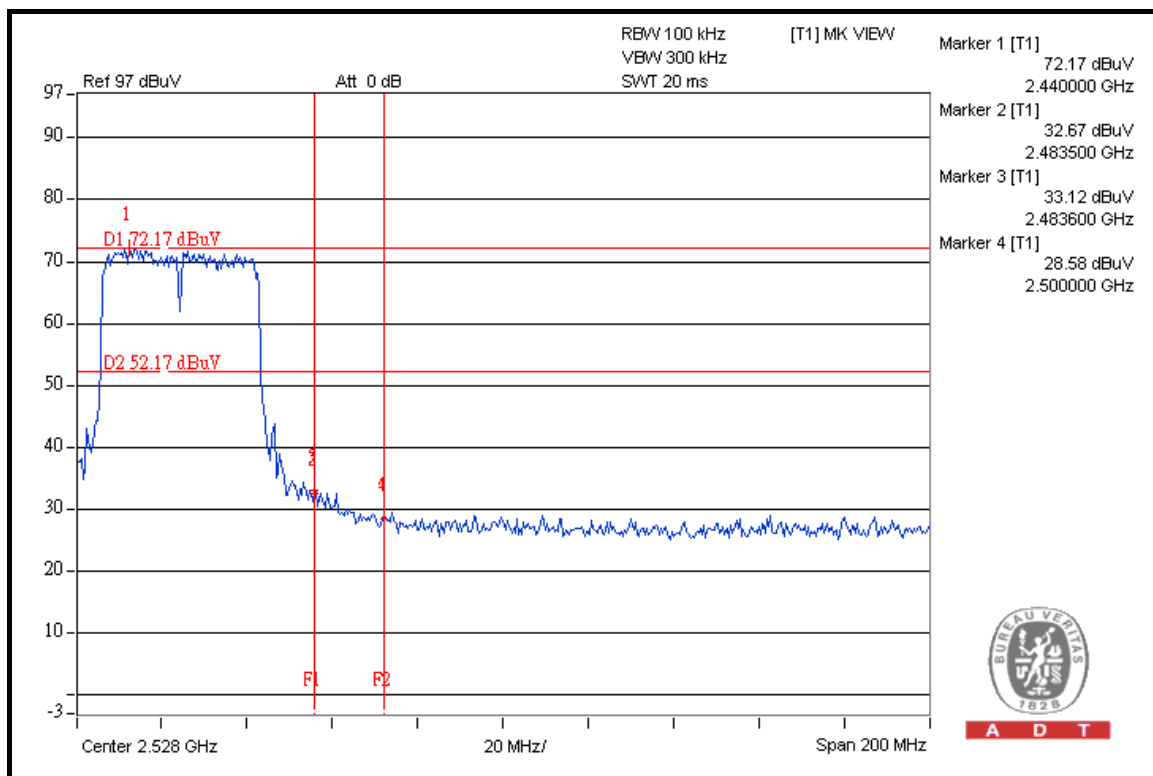
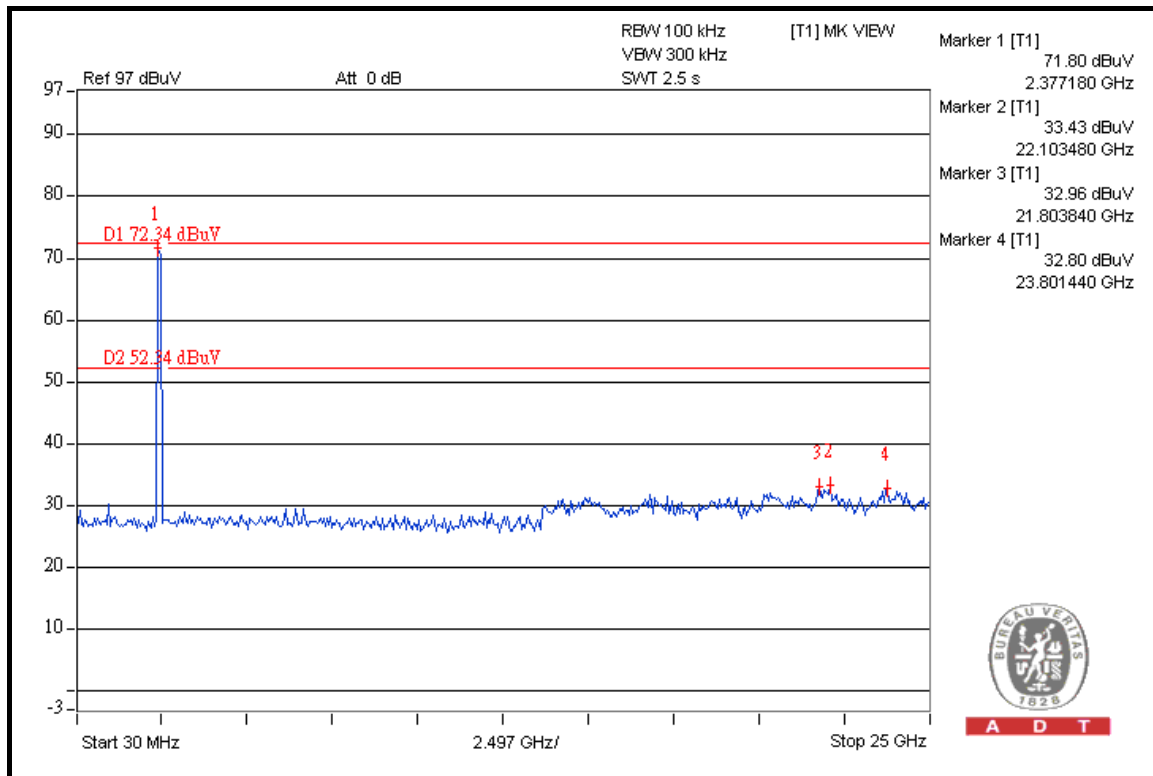



A D T

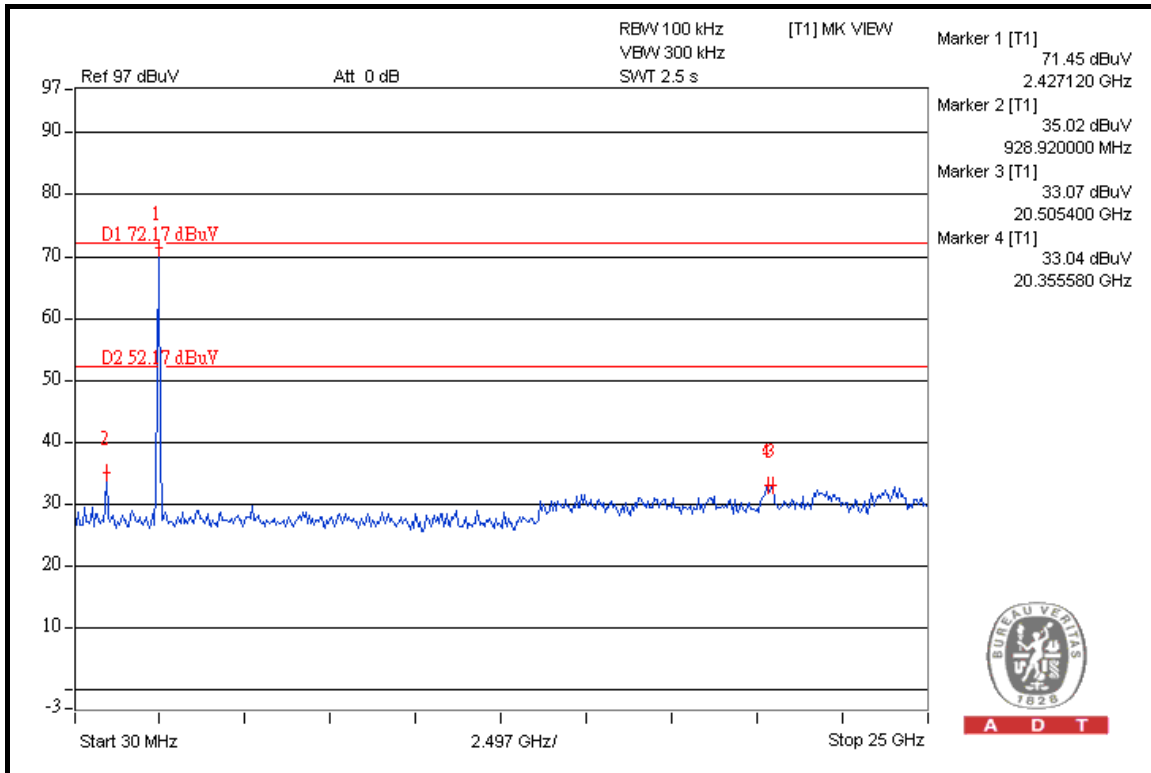
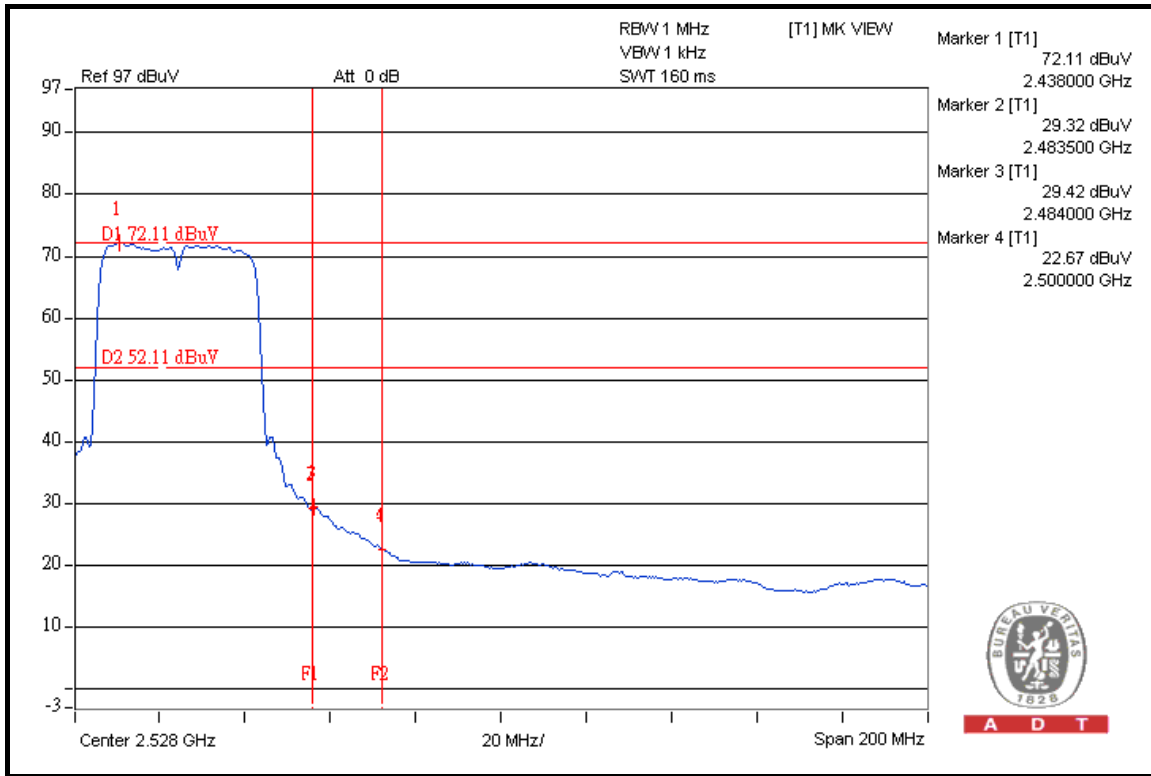

4.7 ANTENNA REQUIREMENT

4.7.1 STANDARD APPLICABLE

For intentional device, according to FCC 47 CFR Section 15.203, an intentional radiator shall be designed to ensure that no antenna other than that furnished by the responsible party shall be used with the device. And according to FCC 47 CFR Section 15.247 (b), if transmitting antennas of directional gain greater than 6dBi are used, the power shall be reduced by the amount in dB that the directional gain of the antenna exceeds 6dBi.

4.7.2 ANTENNA CONNECTED CONSTRUCTION

The antenna used in this product is Printed antenna with MHF antenna connector. The maximum Gain of the antenna is 2.2dBi.

5. PHOTOGRAPHS OF THE TEST CONFIGURATION

Please refer to the attached file (Test Setup Photo).

6. INFORMATION ON THE TESTING LABORATORIES

We, Bureau Veritas Consumer Products Services (H.K.) Ltd., Taoyuan Branch, were founded in 1988 to provide our best service in EMC, Radio, Telecom and Safety consultation. Our laboratories are accredited and approved by the following approval agencies according to ISO/IEC 17025.

USA	FCC, NVLAP
Germany	TUV Rheinland
Japan	VCCI
Norway	NEMKO
Canada	INDUSTRY CANADA, CSA
R.O.C.	TAF, BSMI, NCC
Netherlands	Telefication
Singapore	GOST-ASIA (MOU)
Russia	CERTIS (MOU)

Copies of accreditation certificates of our laboratories obtained from approval agencies can be downloaded from our web site:

www.adt.com.tw/index.5/phtml. If you have any comments, please feel free to contact us at the following:

Linko EMC/RF Lab:

Tel: 886-2-26052180

Fax: 886-2-26051924

Hsin Chu EMC/RF Lab:

Tel: 886-3-5935343

Fax: 886-3-5935342

Hwa Ya EMC/RF/Safety Telecom Lab:

Tel: 886-3-3183232

Fax: 886-3-3185050

Web Site: www.adt.com.tw

The address and road map of all our labs can be found in our web site also.

7. APPENDIX A - MODIFICATIONS RECORDERS FOR ENGINEERING CHANGES TO THE EUT BY THE LAB

No any modifications are made to the EUT by the lab during the test.

--- END ---