



MEASUREMENT/TECHNICAL REPORT
FCC Part 15 Subpart C

Issued: May 12th, 2006

Name and Address of the Applicant:	Buffalo Inc. 15,Shibata Hondori 4,Minami-ku Nagoya, Aichi Japan 457-8520
Test Item:	Wireless LAN Card Adapter
Identification:	"AirStation" WLI-CB-G54S"
Serial No.:	000D0B02F3DB
Sample No.:	1
Sample Receipt Date:	April 4 th , 2006
Test Specification:	CFR 47 Part.15 Subpart C 15.247
Date of Testing:	April 17 th – April 24 th and May 12 th 2006
Test Result:	PASS

Report Prepared by:	Cosmos Corporation 2-3571 Ohnogi, Watarai-cho, Watarai-gun, Mie, Japan 516-2102 Phone: +81-596-63-0707 Fax: +81-596-63-0777
---------------------	---

Tested by:	 D. Watanuki, Engineer	May 12th, 2006 Date
Reviewed by:	 K. Ozaki, Manager	May 12th, 2006 Date

- Notes:
1. This report should not be reproduced except in full, without the written approval of Cosmos Corporation.
 2. All measurement data contained in this report may have uncertainty. A judgment for the limitation should be taken into the count.
 3. The report in this report apply only to the sample tested.

List of Contents **Page**

- 1. Description of Equipment Under Test..... 4
 - 1.1 Product Description..... 4
 - 1.2 Antenna Description..... 4
 - 1.3 Accompanied Peripherals Description 4
- 2. General Information 5
 - 2.1 Test Methodology..... 5
 - 2.2 Test Facility 5
 - 2.3 Traceability 5
- 3. Summary of Test Results 5
- 4. Test Configuration 6
 - 4.1 15. 207 AC Power Conducted Emission in Shield Room 6
 - 4.2 15. 247(c) Transmitter Radiated Emissions and Band Edge (Radiated) in 3m Anechoic Chamber..... 6
 - 4.3 All Other Test Items (Except Maximum Peak Output Power) 7
 - 4.4 Maximum Peak Output Power..... 7
 - 4.5 Test Mode..... 7
- 5. Measurement Result..... 8
 - 5.1 15. 207 AC Power Conducted Emission..... 8
 - 5.1.1 Setting Remarks..... 8
 - 5.1.2 Minimum Standard..... 8
 - 5.1.3 Result 8
 - 5.1.4 Measured Data 9
 - 5.2 15. 247(a)(2) Spectrum Bandwidth of Direct Sequence Spread Spectrum System 11
 - 5.2.1 Setting Remarks..... 11
 - 5.2.2 Minimum Standard..... 11
 - 5.2.3 Result 11
 - 5.2.4 Measured Data 11
 - 5.3 15. 247(b) Maximum Peak Output Power 12
 - 5.3.1 Setting Remarks..... 12
 - 5.3.2 Minimum Standard..... 12
 - 5.3.3 Result 12
 - 5.3.4 Measured Data 13
 - 5.4 15. 247(c) Transmitter Radiated Emissions (Conducted)..... 14
 - 5.4.1 Setting Remarks..... 14
 - 5.4.2 Minimum Standard..... 14
 - 5.4.3 Result 14
 - 5.4.4 Measured Data (No emission exceeding the 20dB limit was found)..... 15

5.5	15. 247(c) Transmitter Radiated Emissions (Radiated)	17
5.5.1	Setting Remarks.....	17
5.5.2	Minimum Standard.....	18
5.5.3	Result	18
5.4.4	Measured Data	19
5.6.1	Setting Remarks.....	26
5.6.2	Minimum Standard.....	26
5.6.3	Result	26
5.6.4	Measured Data	27
5.7	15. 247(c) Band Edge Measurement	31
5.7.1	Setting Remarks.....	31
5.7.2	Minimum Standard.....	31
5.7.3	Result	31
5.7.4	Measured Data	32
6.	Photos.....	35
6.1	Setup Photo (Conducted Emission).....	35
6.2	Setup Photo (Radiated Emission).....	36
7.	List of Test Measurement Instruments	37
7.1	Conducted Emission.....	37
7.2	Radiated Emission Measurement	37
7.3	Conducted Radio Measurement	38

1. Description of Equipment Under Test

1.1 Product Description

Manufacturer : Buffalo Inc.
 Model (referred to as the EUT) : WLI-CB-G54S
 Nominal Voltage : DC 3.3V
 Type of Modulation : DSSS FHSS Other
 FCC ID : FDI-04600046-2
 The type of the equipment : Stand-alone Combined Equipment
 Plug -In Card Other
 The type of the antenna : Integral external Other
 The type of power source : AC mains Dedicated AC adapter (VAC)
 DC Voltage Battery
 The type of battery (if applicable) : N/A
 Type of Operation : Continuous Burst Intermittent
 Stand by Mode : Available N/A
 Intended functions : Wireless data transmission
 The type of modulation : CCK, OFDM
 The bandwidth of the IF filters : 5MHz
 Method of Communication Link : Software to make high speed packet transmitting
 The operating frequency band : 2,412 to 2,462 MHz
 The thermal limitation : 0 to 40 degree

1.2 Antenna Description

The following antenna is provided to EUT as the integrated original antenna.

No.	Type Name	Gain	Antenna Type	Remarks
1	N/A	0.12 dBi	On board metal forming antenna	Originally Integrated.

1.3 Accompanied Peripherals Description

The following equipment is accompanied with EUT as its peripheral.

No.	Equipment Name	Manufacturer	Type Name	Serial Number	Remarks
1	PC	Epson	NT2700	231019561	DC 19V, 3.42A

2. General Information

2.1 Test Methodology

All measurement subject to the present report was carried out according to the procedures in ANSI C63.4: 2003.

2.2 Test Facility

All measurement was performed in the following facility;

Cosmos Corporation EMC Lab. Ohnogi
 (2-3571 Ohaza-iwatachi, Ohnogi, Watarai-cho, Watarai-gun, Mie-ken 516-2102, Japan) This site has been registered July 4th, 2005 by Industry Canada under RSS 212.

2.3 Traceability

The calibration of measurement equipment used in the test subject to the present report is designed and operated to ensure that the measurement is traceable to national standards of measurement or equivalent abroad.

3. Summary of Test Results

Section	Test Item	Limit	Result
15. 207	AC Power Conducted Emission	Limit: 48dBuV	Pass
15. 247(a)(2)	Spectrum Bandwidth of Direct Sequence Spread Spectrum System	Min. 500kHz	Pass
15. 247(b)	Maximum Peak Output Power	Max. 30dBm	Pass
15. 247(c)	Transmitter Radiated Emissions	20dB less than the peak value	Pass
15. 247(d)	Power Spectrum Density	Max. 8dBm	Pass
15. 247(c)	Band Edge Measurement	Refer to 15. 209	Pass

4. Test Configuration

4.1 15. 207 AC Power Conducted Emission in Shield Room

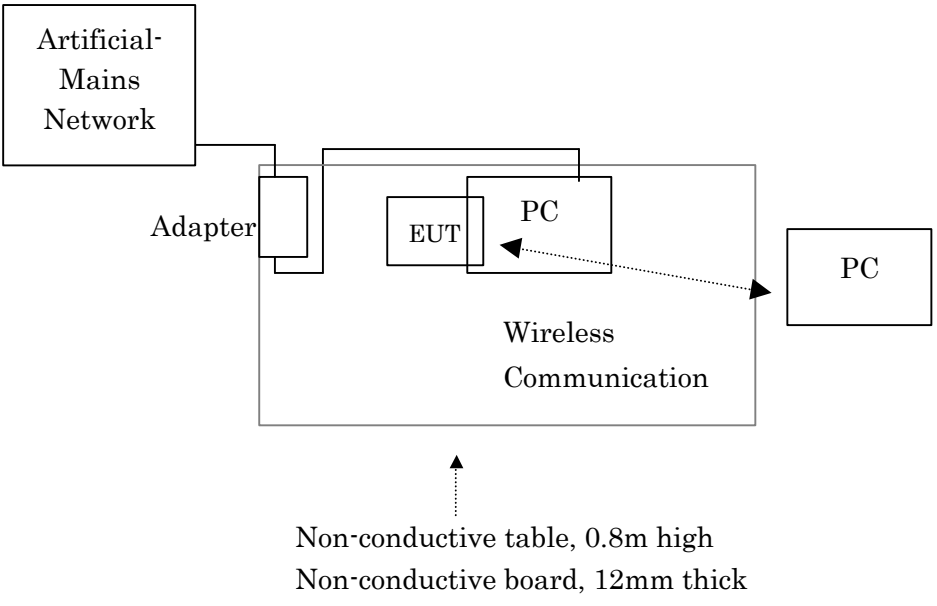

4.2 15. 247(c) Transmitter Radiated Emissions and Band Edge (Radiated) in 3m Anechoic Chamber

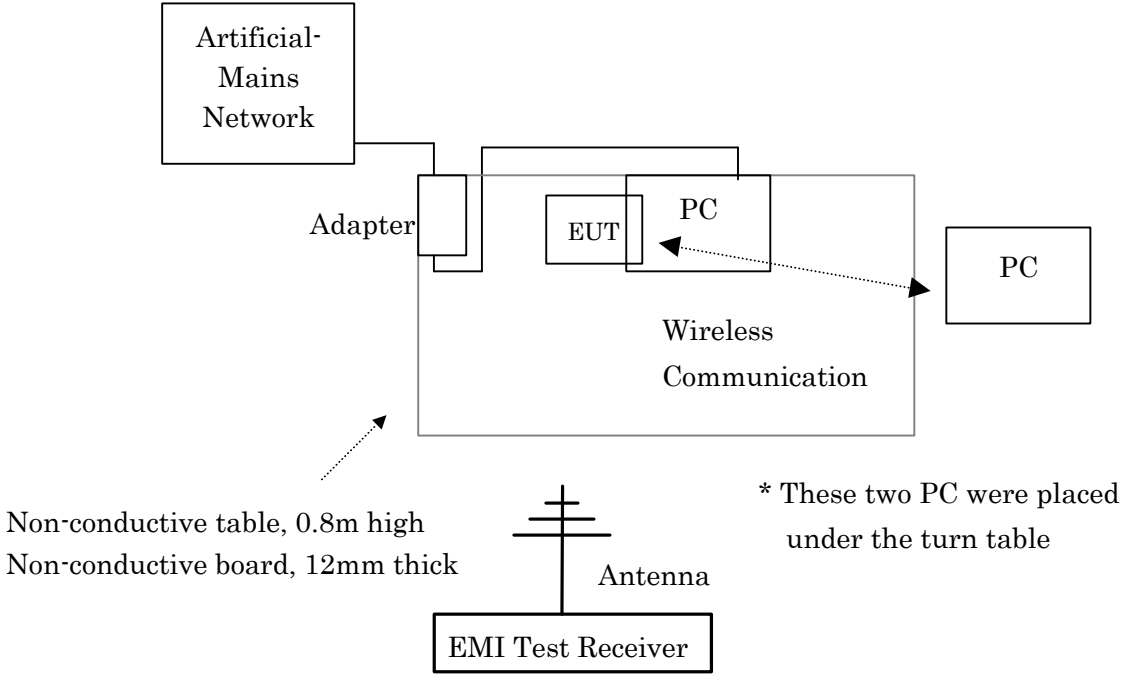

4.3 All Other Test Items (Except Maximum Peak Output Power)

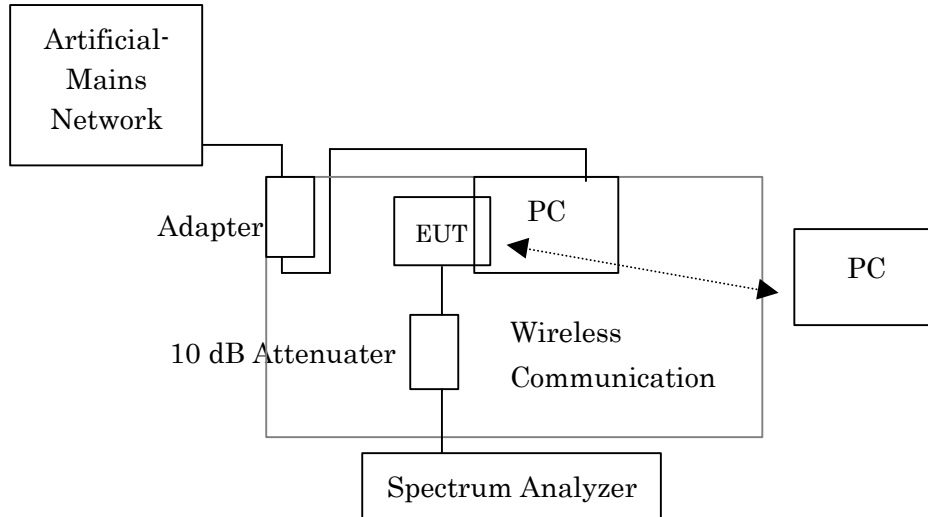

4.4 Maximum Peak Output Power

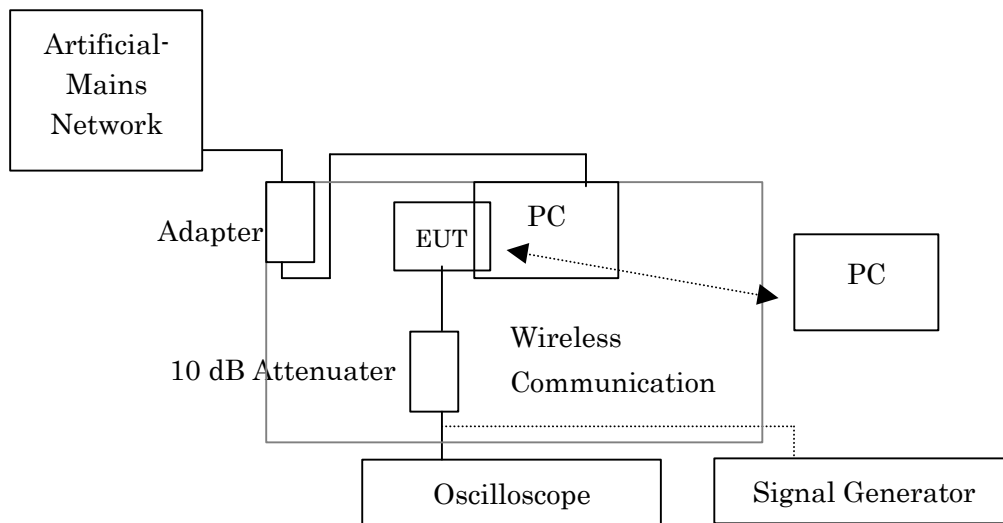

4.5 Test Mode

In all test configurations above, EUT and the support PC made communication link by First Packet Transmitting Software. The software provides channel selection, change modulation type, where necessary.

All conducted measurement was performed with an external stabilized power supply voltage varied between 85% and 115% of the nominal rated supply voltage in accordance with the section 15.31 (e) of the part.

5. Measurement Result

5.1 15. 207 AC Power Conducted Emission

5.1.1 Setting Remarks

- Configure the EUT System in accordance with ANSI C63.4-2003.
- A wooden test table (1.5m×1.0m, height 0.8m) was used.
- EUT's dedicated AC adapter connected to Artificial Mains Network (AMN).
- Other power cord of support equipment is connected to another AMN to isolate its emission from the measured emission of EUT.
- The measuring port of AMN for support equipment was terminated by the 500
- Activate the EUT System and run the software prepared for the test, if necessary.
- Refer to test configuration figure 4.1.

5.1.2 Minimum Standard

(a) Except as shown in paragraphs (b) and (c) of this section, for an intentional radiator that is designed to be connected to the public utility (AC) power line, the radio frequency voltage that is conducted back onto the AC power line on any frequency or frequencies within the band 150 kHz to 30 MHz shall not exceed the limits in the following table, as measured using a 50 μH/50 ohms line impedance stabilization network (LISN). Compliance with the provisions of this paragraph shall be based on the measurement of the radio frequency voltage between each power line and ground at the power terminal. The lower limit applies at the boundary between the frequency ranges.

Frequency of Emission (MHz)	Conducted Limit (dBuV)	
	Quasi-peak	Average
0.15-0.5	66 to 56 *	56 to 46 *
0.5-5	56	46
5-30	60	50

* Decreases with the logarithm of the frequency.

5.1.3 Result

EUT complies with the requirement.

Uncertainty of measurement : ± 2.26 dB
 Temperature, Humidity : 19°C, 33%

5.1.4 Measured Data

Measured Value Table

Model Name : WLI-CB-G54S
 Serial No. :
 Operator : K.Yamashita
 Power Supply : DC 3.3V

Job No : CJ06-052924E
 Temp/Humi : 19 /33%
 Condition : Operated
 Remark : PC : AC 120V, 60Hz

Memo :

LIMIT : FCC Part 15 SubpartC ClassB QP
 FCC Part 15 SubpartC ClassB AV

No	Freq. [MHz]	Reading Level		C.Fac [dB]	Results		Limit		Margin		Phase	Comment
		QP	AV		QP	AV	QP	AV	QP	AV		
		[dBuV]	[dBuV]		[dBuV]	[dBuV]	[dBuV]	[dBuV]	[dB]	[dB]		
1	0.15011	27.7	4.4	10.8	38.5	15.2	66.0	56.0	27.5	40.8	La	
2	0.20524	36.8	28.5	10.4	47.2	38.9	63.4	53.4	16.2	14.5	La	
3	0.27317	31.6	23.8	10.3	41.9	34.1	61.0	51.0	19.1	16.9	La	
4	0.34099	24.4	17.5	10.3	34.7	27.8	59.2	49.2	24.5	21.5	La	
5	0.41117	29.4	25.9	10.3	39.7	36.2	57.6	47.6	18.0	11.4	La	
6	0.48030	22.0	18.1	10.4	32.4	28.5	56.3	46.3	23.9	17.8	La	
7	0.61883	17.1	13.8	10.5	27.6	24.3	56.0	46.0	28.4	21.7	La	
8	1.98380	15.5	13.6	10.6	26.1	24.2	56.0	46.0	29.9	21.8	La	
9	5.06880	17.1	11.8	10.6	27.7	22.4	60.0	50.0	32.3	27.6	La	
10	14.24554	17.1	15.1	11.4	28.5	26.5	60.0	50.0	31.5	23.5	La	
11	0.15001	27.5	4.4	10.8	38.3	15.2	66.0	56.0	27.7	40.8	Lb	
12	0.20559	37.2	28.4	10.4	47.6	38.8	63.4	53.4	15.8	14.6	Lb	
13	0.27412	30.3	23.8	10.3	40.6	34.1	61.0	51.0	20.4	16.9	Lb	
14	0.34211	23.6	16.4	10.3	33.9	26.7	59.2	49.2	25.3	22.6	Lb	
15	0.41203	27.1	24.4	10.3	37.4	34.7	57.6	47.6	20.2	12.9	Lb	
16	0.47931	21.3	17.9	10.4	31.7	28.3	56.4	46.4	24.7	18.1	Lb	
17	0.61631	17.4	14.7	10.5	27.9	25.2	56.0	46.0	28.1	20.9	Lb	
18	1.85222	14.5	12.7	10.6	25.1	23.3	56.0	46.0	30.9	22.7	Lb	
19	5.06553	17.1	10.9	10.6	27.7	21.5	60.0	50.0	32.3	28.5	Lb	
20	14.51563	16.7	13.3	11.2	27.9	24.5	60.0	50.0	32.2	25.5	Lb	

Peak Hold Wave Form

Model Name	: WLI-CB-G54S	Job No	: CJ06-052924E
Serial No.	:	Temp/Humi	: 19 /33%
Operator	: K.Yamashita	Condition	: Operated
Power Supply	: DC 3.3V	Remark	: PC : AC 120V, 60Hz
Memo	:		

LIMIT : FCC Part 15 SubpartC ClassB QP
FCC Part 15 SubpartC ClassB AV

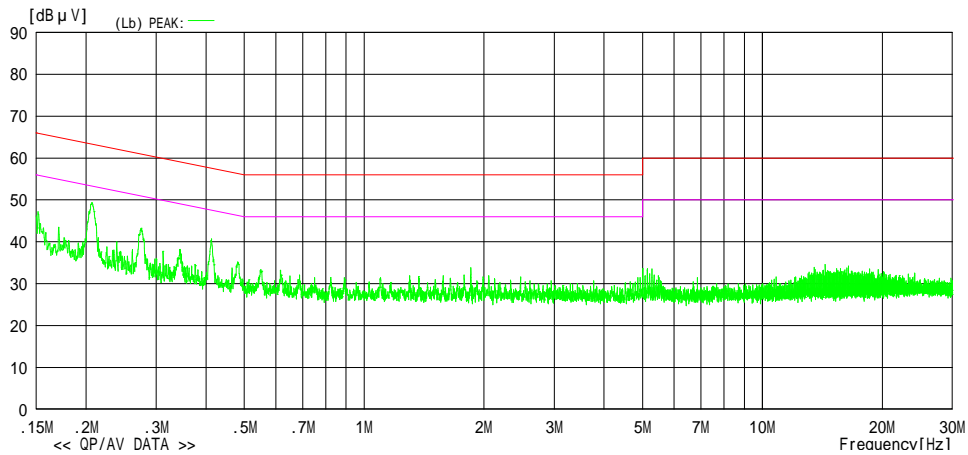
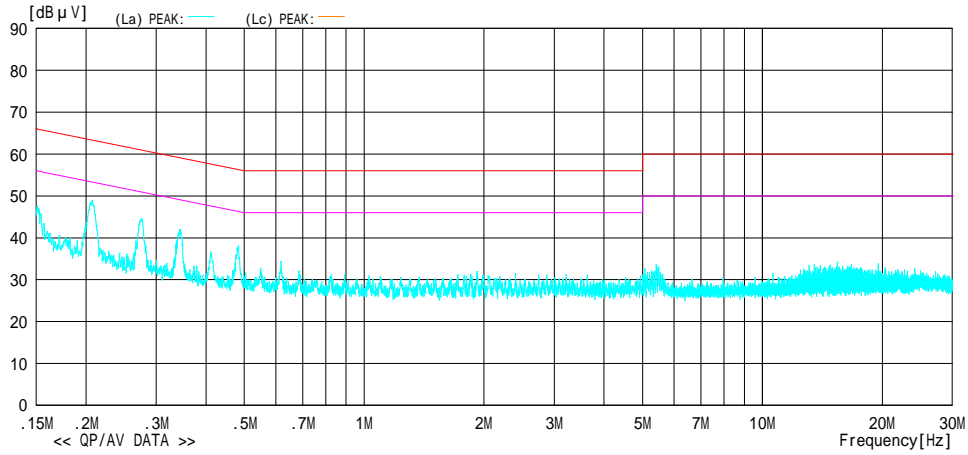

5.2 15. 247(a)(2) Spectrum Bandwidth of Direct Sequence Spread Spectrum System

5.2.1 Setting Remarks

- The both side of 6dB down value from peak power were measured by using delta-maker function of the spectrum analyzer.
- The spectrum analyzer was set-up as following;

- ✓ Frequency Span : 30 MHz
- ✓ Resolution bandwidth : 100 kHz
- ✓ Video bandwidth : 300 kHz
- ✓ Sweep : 1sec
- ✓ Detector function : Peak
- ✓ Trace Mode : Max Hold

- Refer to test configuration figure 4.1.

5.2.2 Minimum Standard

(2) Systems using digital modulation techniques may operate in the 902 - 928 MHz, 2400 - 2483.5 MHz, and 5725 - 5850 MHz bands. The minimum 6 dB bandwidth shall be at least 500 kHz.

5.2.3 Result

EUT complies with the requirement.

Uncertainty of measurement : ± 0.8 dB
 Temperature, Humidity : 23 °C, 39%

5.2.4 Measured Data

Frequency (MHz)	Measured Bandwidth (MHz)	Limit (MHz)
CCK (11Mbps)		
2412 (1ch)	10.56	> 0.5
2437 (6ch)	10.20	> 0.5
2462 (11ch)	10.38	> 0.5
OFDM (54 Mbps)		
2412 (1ch)	16.68	> 0.5
2437 (6ch)	16.68	> 0.5
2462 (11ch)	16.38	> 0.5

5.3 15. 247(b) Maximum Peak Output Power

5.3.1 Setting Remarks

- Refer to test configuration figure 4.4.
- The maximum peak output power was measured as following;
 1. The diode detector is inserted between EUT and the oscilloscope.
 2. The oscilloscope was used to read the peak response of the detector.
 3. Replaced EUT by the signal generator (SG).
 4. Adjusted the frequency of SG to the fundamental frequency.
 5. Adjusted the amplitude of SG to be the same peak recorded in 2.
- The spectrum analyzer was set-up as following;
 - ✓ Voltage level range : 10 mV / Div
 - ✓ Sampling time : 1.00GS / s
 - ✓ Function : Peak search

5.3.2 Minimum Standard

The maximum peak output power shall not exceed 1 watt. If transmitting antennas of directional gain greater than 6 dBi are used, the power shall be reduced by the amount in dB that the directional gain of the antenna exceeds 6 dBi.

5.3.3 Result

EUT complies with the requirement.

Uncertainty of measurement result: ± 0.5 dB
Temperature, Humidity : 17 °C, 39%

5.3.4 Measured Data

(Normal Rated Voltage, 120 VAC)

Frequency (MHz)	Peak Voltage (mV)	Peak Power (dBm)	Limit (dB)	Margin (dB)
CCK (11 Mbps)				
2412 (1ch)	194	20.8	30	9.2
2437 (6ch)	206	21.2	30	8.8
2462 (11ch)	206	21.0	30	9.0
OFDM (54 Mbps)				
2412 (1ch)	254.00	23.3	30	6.7
2437 (6ch)	258	23.3	30	6.7
2462 (11ch)	270	23.7	30	6.3

(High-varied voltage, 138 VAC)

Frequency (MHz)	Peak Voltage (mV)	Peak Power (dBm)	Limit (dB)	Margin (dB)
CCK (11 Mbps)				
2412 (1ch)	190	20.6	30	9.4
2437 (6ch)	206	21.2	30	8.8
2462 (11ch)	206	21.0	30	9.0
OFDM (54 Mbps)				
2412 (1ch)	246	23.1	30	6.9
2437 (6ch)	254	23.1	30	6.9
2462 (11ch)	274	23.9	30	6.1

(Low-varied voltage, 102 VAC)

Frequency (MHz)	Peak Voltage (mV)	Peak Power (dBm)	Limit (dB)	Margin (dB)
CCK (11 Mbps)				
2412 (1ch)	190	20.6	30	9.4
2437 (6ch)	202	20.9	30	9.1
2462 (11ch)	206	21.0	30	9.0
OFDM (54 Mbps)				
2412 (1ch)	250	23.3	30	6.7
2437 (6ch)	250	23.0	30	7.0
2462 (11ch)	274	23.9	30	6.1

5.4 15. 247(c) Transmitter Radiated Emissions (Conducted)

5.4.1 Setting Remarks

- EUT directly connects to the spectrum analyzer via calibrated coaxial cable and 10 dB attenuator.
- The Spectrums are scanned from the lowest generated frequency of EUT up to the 10th harmonics by using the spectrum analyzer.
- The spectrum analyzer was set-up as following;
 - ✓ Resolution bandwidth : 100 kHz
 - ✓ Video bandwidth : 100 kHz
 - ✓ Sweep : Auto
 - ✓ Detector function : Peak
 - ✓ Trace Mode : Max Hold
- Refer to test configuration figure 4.3.

5.4.2 Minimum Standard

(d) In any 100 kHz bandwidth outside the frequency band in which the spread spectrum or digitally modulated intentional radiator is operating, the radio frequency power that is produced by the intentional radiator shall be at least 20 dB below that in the 100 kHz bandwidth within the band that contains the highest level of the desired power, based on either an RF conducted or a radiated measurement, provided the transmitter demonstrates compliance with the peak conducted power limits. If the transmitter complies with the conducted power limits based on the use of RMS averaging over a time interval, as permitted under paragraph (b)(3) of this section, the attenuation required under this paragraph shall be 30 dB instead of 20 dB. Attenuation below the general limits specified in Section 15.209(a) is not required.

5.4.3 Result

EUT complies with the requirement.

Uncertainty of measurement result: ± 0.8 dB
Temperature, Humidity : 17 °C, 39%

5.4.4 Measured Data (No emission exceeding the 20dB limit was found)

2412 MHz (1ch)



2437 MHz (6ch)



2462 MHz (11ch)



5.5 15. 247(c) Transmitter Radiated Emissions (Radiated)

5.5.1 Setting Remarks

- The data lists in “5.5.4 Measured Data “ list the significant emission frequencies, measured levels, correction factor (includes cable and antenna corrections), the corrected reading, plus the limit.
- In the frequency range between 30MHz to 25 GHz (as 10th harmonics), the Electric Field Strength was measured in accordance with ANSI C63.4: 2003 and CISPR22: 1997.
- The test setup was made in accordance with ANSI C63.4: 2003.
- The antenna was measured at 1-4m height.
- The EUT was placed on the non-conductive table in the center of turntable. The height of this table was 0.8m.
- The measurement was carried out with both horizontal and vertical antenna polarization.
- The highest radiation from the equipment was recorded.
- By varying the configuration of the test sample and the cable routing, it was attempted to maximize the emission.
- The test receiver with Quasi Peak and Average detector is in compliance with CISPR 16-1:1993.
- The spectrum analyzer was set-up as following;

(Frequency range : 30 - 1000 MHz)

- ✓ Resolution bandwidth : 100 kHz
- ✓ Video bandwidth : 300 kHz
- ✓ Detector function : Peak
- ✓ Trace Mode : Max Hold

(Frequency range : Above 1000 MHz)

- ✓ Resolution bandwidth : 1 MHz
- ✓ Video bandwidth : 1 MHz
- ✓ Detector function : Peak
- ✓ Trace Mode : Max Hold

- EMI Test Receiver analyzer was set-up as following;
 - ✓ IF bandwidth : 120 kHz (Quasi-Peak Detector)
 - ✓ IF bandwidth : 1 MHz (Average Detector)
- Refer to test configuration figure 4.2.

5.5.2 Minimum Standard

In addition, radiated emissions which fall in the restricted bands, as defined in Section 15.205(a), must also comply with the radiated emission limits specified in Section 15.209(a) (see Section 15.205(c)).

5.5.3 Result

EUT complies with the requirement.

Uncertainty of measurement result: ± 3.28 dB

Temperature, Humidity : Refer to each data table

*Note Through all frequencies, no significant noise was detected.

5.4.4 Measured Data

30MHz to 1GHz, Channel 1

Model Name	: WLI-CB-G54S	Job No	: CJ06-052924E
Serial No.	:	Temp./Humi.	: 26 /44%
Operator	: K.Yamashita	Condition	: Operated
Power Supply	: AC100V,60Hz	Remark	:

Memo :
 Data Comment : CJ06-052924E RE 30-1000MHz Total05 CH1 ant.1FCC 3m

LIMIT : Fcc15C 15_209 (3m) 30MHz-1000MHz

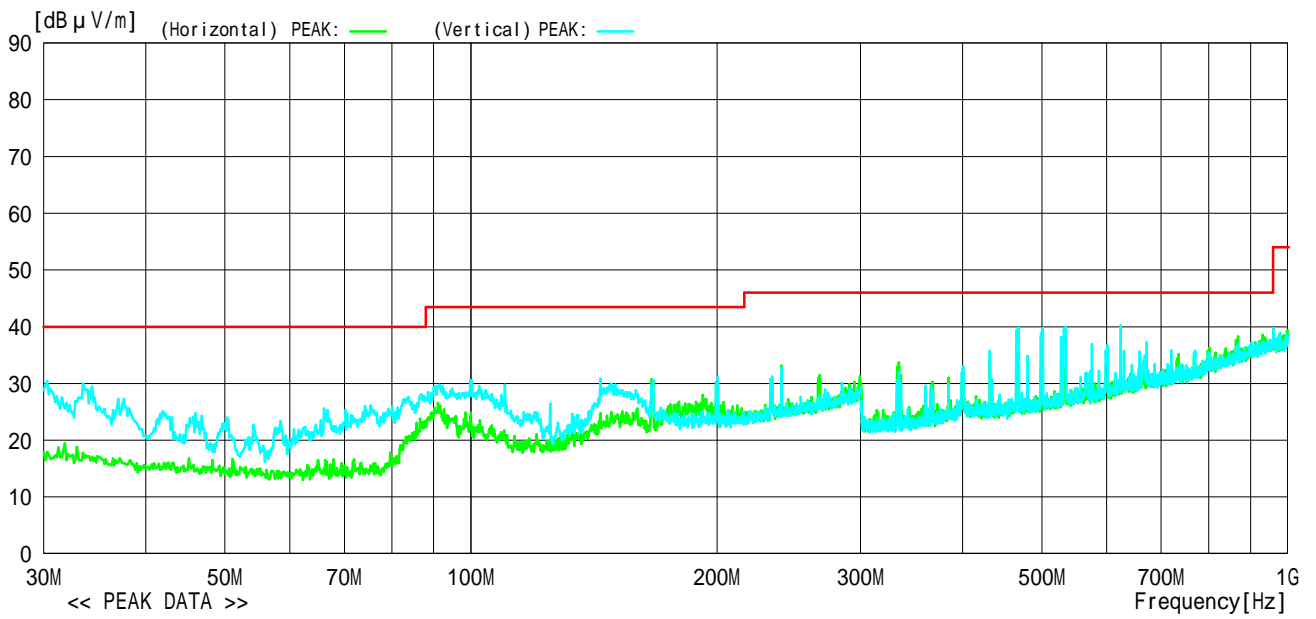

No	Freq.	Reading	C.Fac	Result	Limit	Margin	Pola.	Height	Angle	Ant
	[MHz]	[dBuV]	[dB/m]	[dBuV/m]	[dBuV/m]	[dB]	[H/V]	[cm]	[deg]	Type
*No significant spurious was detected.										

30MHz to 1GHz, Channel 6

Model Name	: WLI-CB-G54S	Job No	: CJ06-052924E
Serial No.	:	Temp./Humi.	: 26 /44%
Operator	: K.Yamashita	Condition	: Operated
Power Supply	: AC100V,60Hz	Remark	:

Memo :
 Data Comment : CJ06-052924E RE 30-1000MHz TotalI01 CH6 ant.1FCC 3m

LIMIT : Fcc15C 15_209 (3m) 30MHz-1000MHz

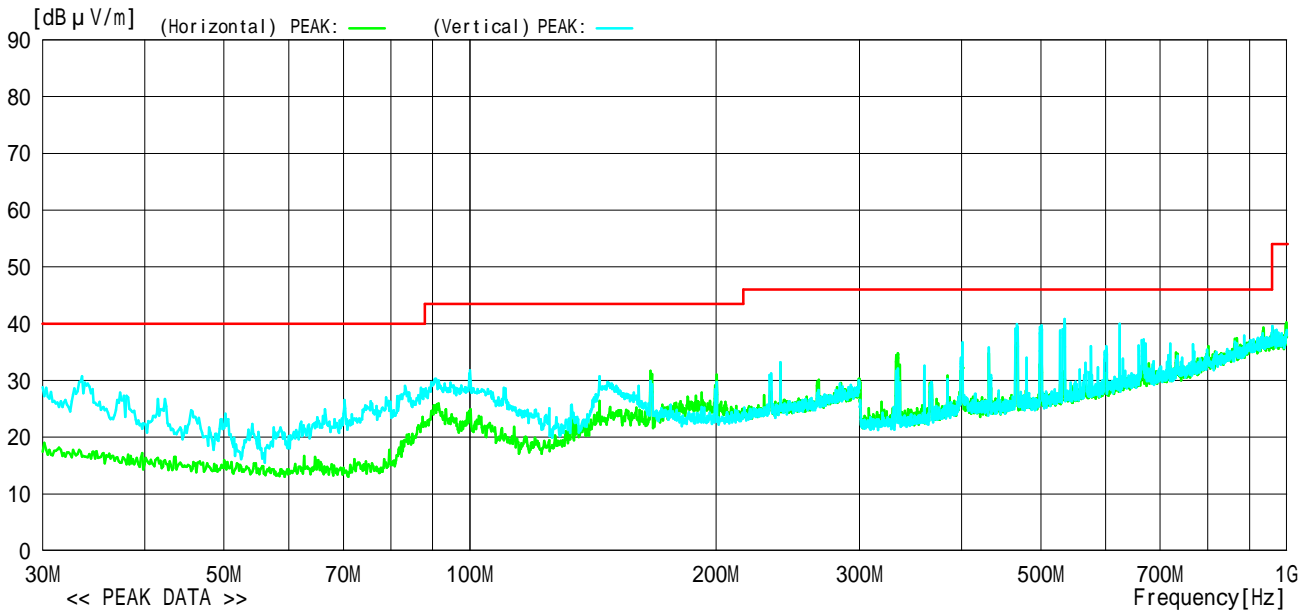

No	Freq.	Reading	C.Fac	Result	Limit	Margin	Pola.	Height	Angle	Ant
	[MHz]	[dBuV]	[dB/m]	[dBuV/m]	[dBuV/m]	[dB]	[H/V]	[cm]	[deg]	Type
*No significant spurious was detected.										

30MHz to 1GHz, Channel 11

Model Name	: WLI-CB-G54S	Job No	: CJ06-052924E
Serial No.	:	Temp./Humi.	: 26 /44%
Operator	: K.Yamashita	Condition	: Operated
Power Supply	: AC100V,60Hz	Remark	:

Memo :
Data Comment : CJ06-052924E RE 30-1000MHz Total06 CH11 ant.1FCC 3m

LIMIT : Fcc15C 15_209 (3m) 30MHz-1000MHz

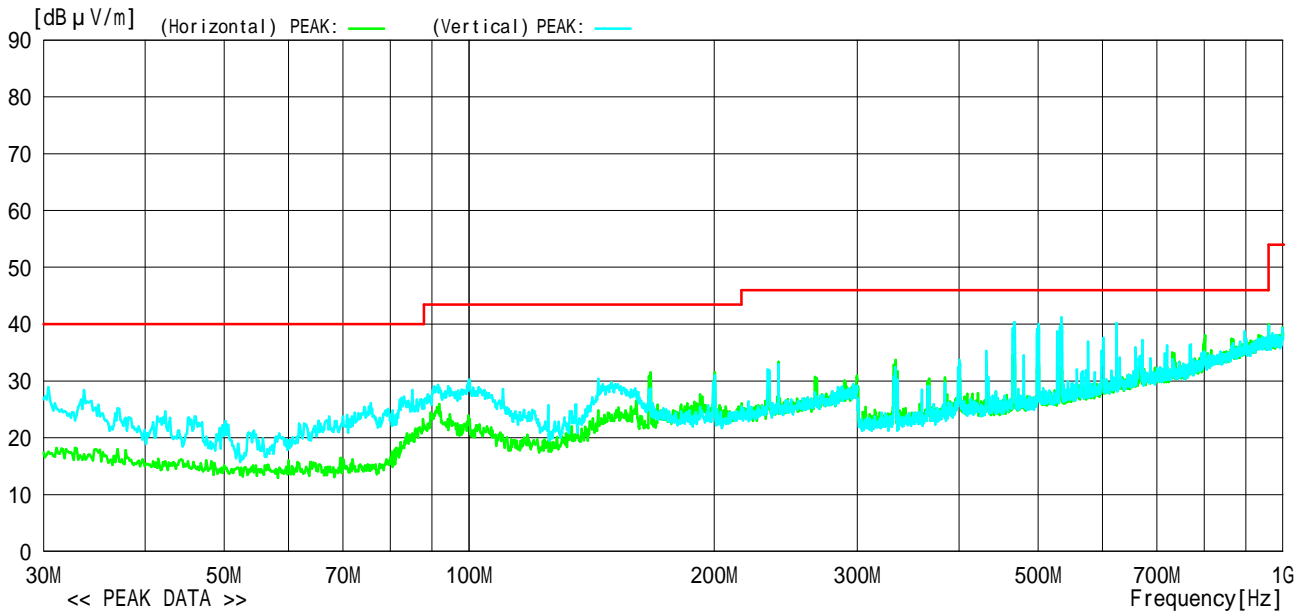

No	Freq.	Reading	C.Fac	Result	Limit	Margin	Pola.	Height	Angle	Ant
	[MHz]	[dBuV]	[dB/m]	[dBuV/m]	[dBuV/m]	[dB]	[H/V]	[cm]	[deg]	Type
*No significant spurious was detected.										

1GHz to 5GHz, Channel 1

Model Name : WLI-CB-G54S
 Model No. :
 Serial No. :
 Test Condition : Operated

Job No. : CJ06-052924E
 Power Supply : AC120V, 60Hz
 Temp/Humi : 25deg. 35%
 Operator : K. Yamashita

Memo : CH 1
 Data Comment :

LIMIT : FCC Subpart C 15.209 (3m) 1G-26.5GHz(PK)

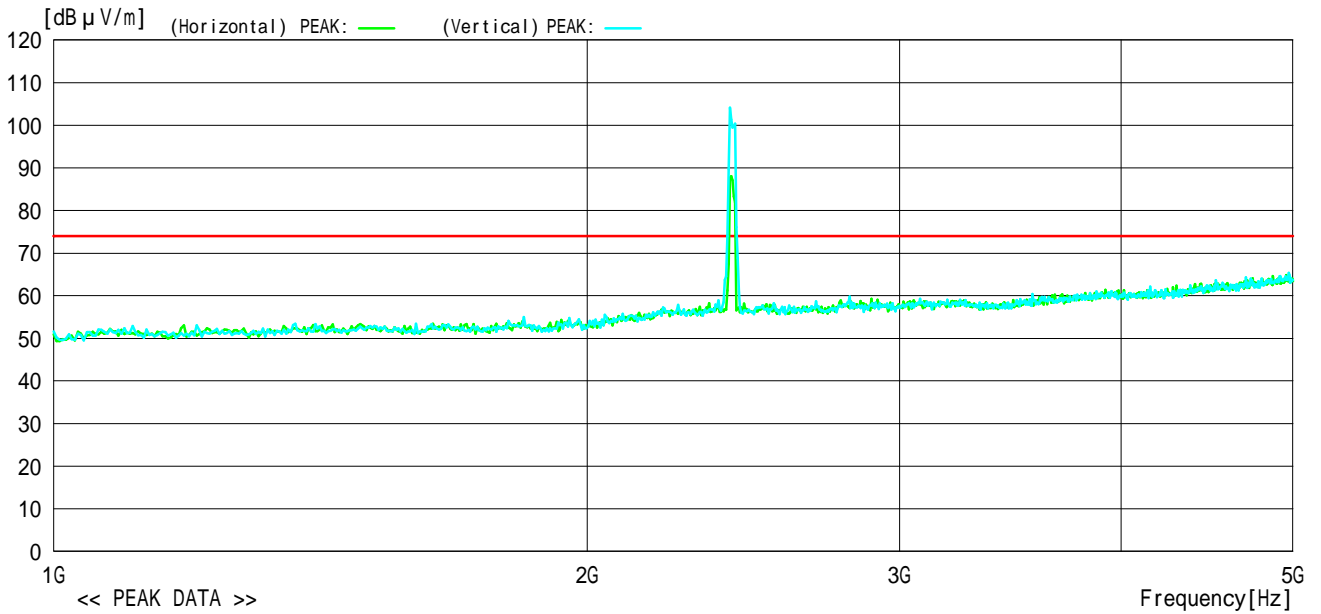

No	Freq.	Reading	C.Fac	Result	Limit	Margin	Pola.	Height	Angle	Ant
	[MHz]	[dBuV]	[dB/m]	[dBuV/m]	[dBuV/m]	[dB]	[H/V]	[cm]	[deg]	Type
1	2406.808	72.0	32.1	104.1	74.0	-30.1	Vert.	100	298	HRN
2	4971.936	25.1	38.3	63.4	74.0	10.6	Hori.	100	13	HRN

1GHz to 5GHz, Channel 6

Model Name : WLI-CB-G54S
 Model No. :
 Serial No. :
 Test Condition : Operated

Job No. : CJ06-052924E
 Power Supply : AC120V, 60Hz
 Temp/Humi : 25deg. 35%
 Operator : K. Yamashita

Memo :
 Data Comment :

LIMIT : FCC Subpart C 15.209 (3m) 1G-26.5GHz(PK)

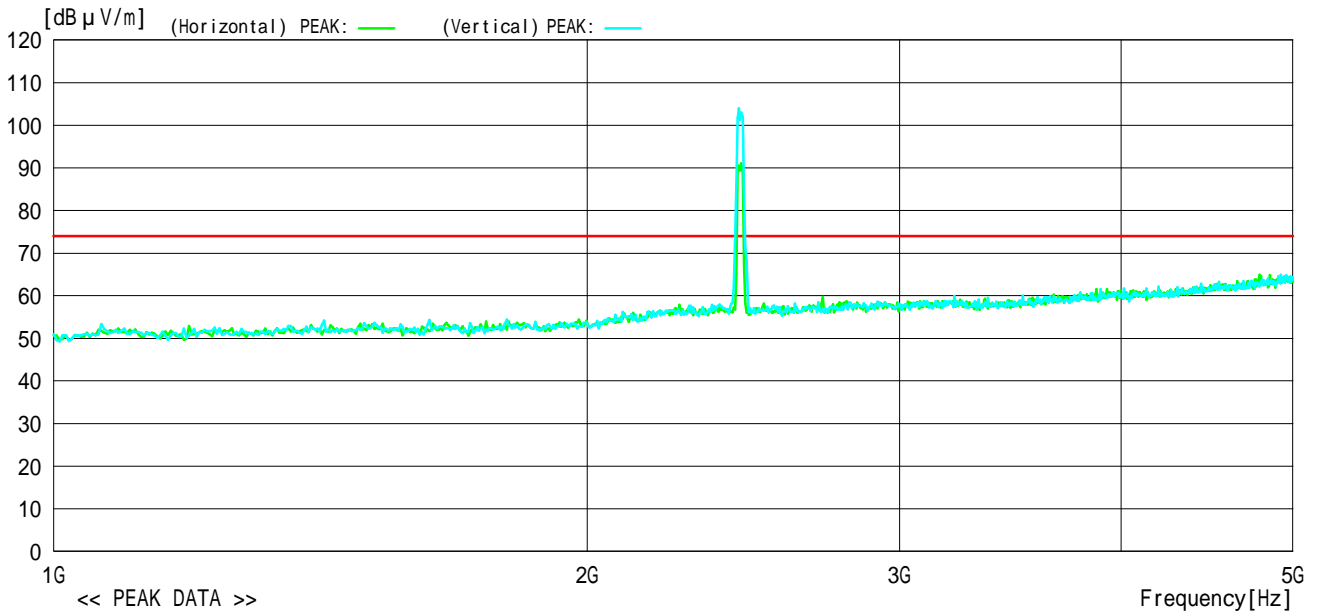

No	Freq.	Reading	C.Fac	Result	Limit	Margin	Pola.	Height	Angle	Ant
	[MHz]	[dBuV]	[dB/m]	[dBuV/m]	[dBuV/m]	[dB]	[H/V]	[cm]	[deg]	Type
1	2434.864	71.6	32.3	103.9	74.0	-29.9	Vert.	100	1	HRN
2	4735.464	25.6	37.9	63.5	74.0	10.5	Vert.	100	358	HRN
3	4735.464	24.7	37.9	62.6	74.0	11.4	Hori.	100	32	HRN

1GHz to 5GHz, Channel 11

Model Name : WLI-CB-G54S
 Serial No. :
 Operator : K. Yamashita
 Power Supply : DC 3.3 V

Job No. : CJ05-05061E
 Temp/Humi : 25deg. 36%
 Condition : Operated
 Remark : CH 11

Memo :
 Data Comment :

LIMIT : FCC Subpart C 15.209 (3m) 1G-26.5GHz(PK)

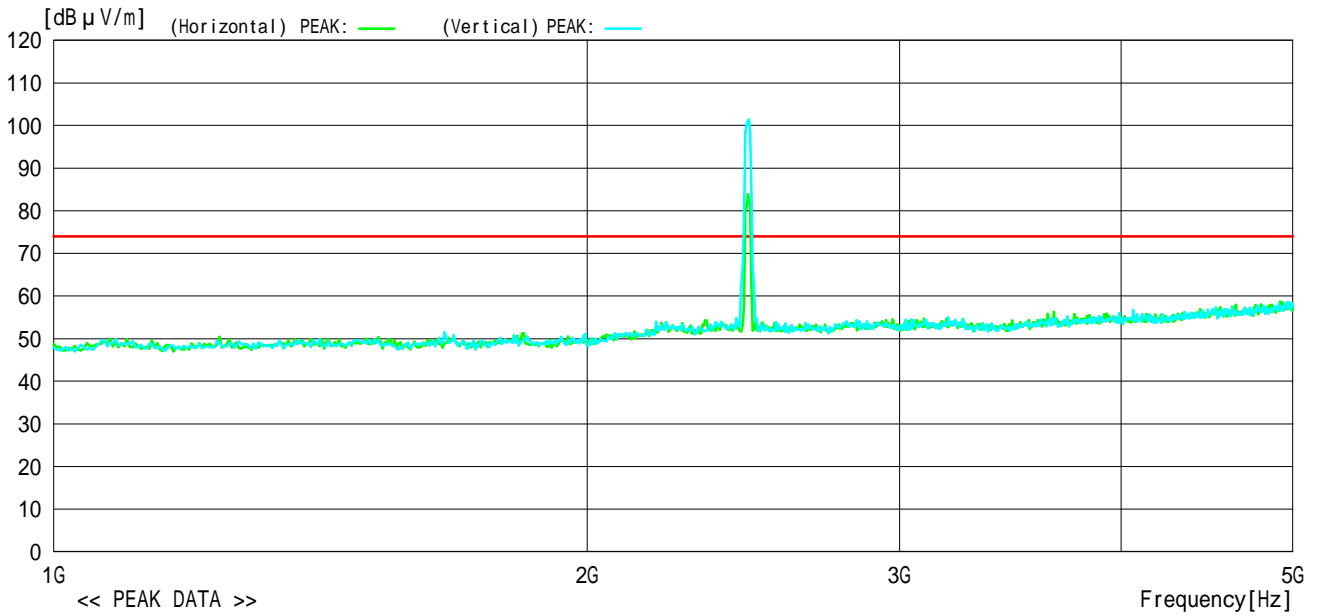

No	Freq.	Reading	C.Fac	Result	Limit	Margin	Pola.	Height	Angle	Ant
	[MHz]	[dBuV]	[dB/m]	[dBuV/m]	[dBuV/m]	[dB]	[H/V]	[cm]	[deg]	Type
1	2466.928	73.3	28.1	101.4	74.0	-27.4	Vert.	100	242	HRN
2	4915.824	26.7	31.9	58.6	74.0	15.4	Hori.	100	0	HRN

Measured data table for 1 to 25 GHz

Ch.	Frequency (MHz)	Peak (dBuV/m)	Average (dBuV/m)	Pola.	Pk. Limit (dBuV/m)	Margin (dBuV/m)	Av. Limit (dBuV/m)	Margin (dBuV/m)
1	*2406.808	104.10	?	Hori.				
1	4,971.936	63.40	52.1	Hori.	74.0	10.6	54.0	1.9
1	7,220.420	63.50	47.8	Hori.	74.0	10.5	54.0	6.2
6	*2434.864	103.90	?	Hori.				
6	4,735.464	63.50	51.0	Hori.	74.0	10.5	54.0	3.0
6	7,304.590	63.80	45.7	Hori.	74.0	10.2	54.0	8.3
11	*2,462.928	101.40	?	Hori.				
11	4,915.824	58.60	51.1	Hori.	74.0	15.4	54.0	2.9
11	7,388.760	65.00	52.9	Hori.	74.0	9.0	54.0	1.1

* Fundamental frequency

5.6 15. 247(d) Power Spectrum Density

5.6.1 Setting Remarks

- EUT directly connects to the spectrum analyzer via calibrated coaxial cable and 10 dB attenuator.
- The loss of the coaxial cable is maximum 1 dB.
- The peak output power was determined by using the marker-data function of spectrum analyzer.
- The spectrum analyzer was set-up as following;
 - ✓ Frequency Span : 1.5 MHz
 - ✓ Resolution bandwidth : 3 kHz
 - ✓ Video bandwidth : 3 MHz
 - ✓ Sweep : 500sec
 - ✓ Detector function : Peak
 - ✓ Trace Mode : Max Hold
- Refer to test configuration figure 4.3.

5.6.2 Minimum Standard

(e) For digitally modulated systems, the power spectral density conducted from the intentional radiator to the antenna shall not be greater than 8 dBm in any 3 kHz band during any time interval of continuous transmission. This power spectral density shall be determined in accordance with the provisions of paragraph (b) of this section. The same method of determining the conducted output power shall be used to determine the power spectral density.

5.6.3 Result

EUT complies with the requirement.

Uncertainty of measurement result: ± 0.8 dB
Temperature, Humidity : 21 °C, 42%

5.6.4 Measured Data

Frequency (MHz)	Correction Factor (dB)	Reading (dBm)	Peak Power (dBm)	Limit (dBm)	Margin (dB)
CCK (11 Mbps)					
2412 (1ch)	11	-16.13	-5.13	8	13.13
2437 (6ch)	11	-16.39	-5.39	8	13.39
2462 (11ch)	11	-16.31	-5.31	8	13.31
OFDM (54 Mbps)					
2412 (1ch)	11	-22.10	-11.10	8	19.10
2437 (6ch)	11	-24.02	-13.02	8	21.02
2462 (11ch)	11	-22.23	-11.23	8	19.23

* Correction Factor = Cable Loss (dB) + External Attenuator (dB)

2412 MHz (1ch), CCK (11Mbps)

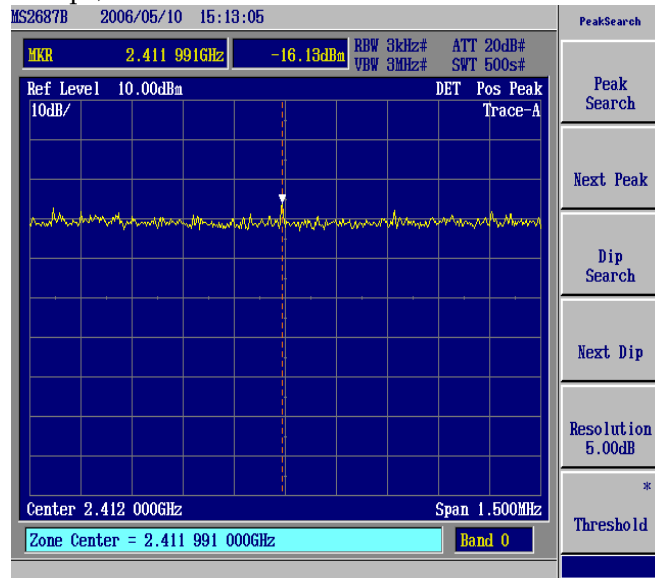

2437 MHz (6ch), CCK (11Mbps)

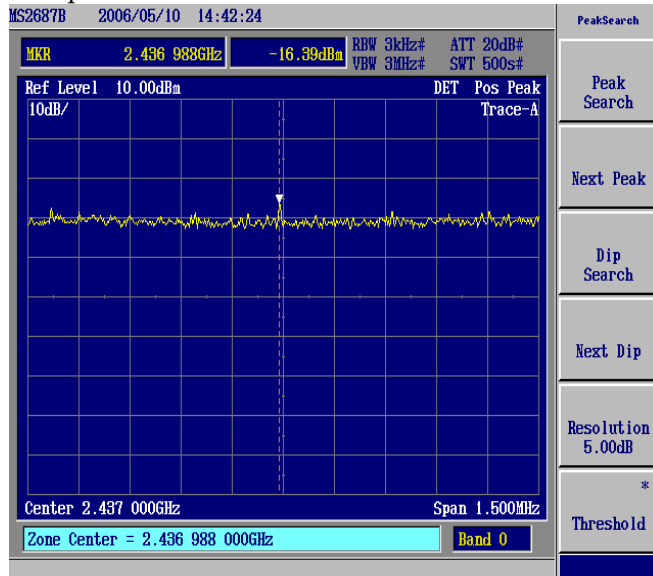

2462 MHz (11ch), CCK (11Mbps)

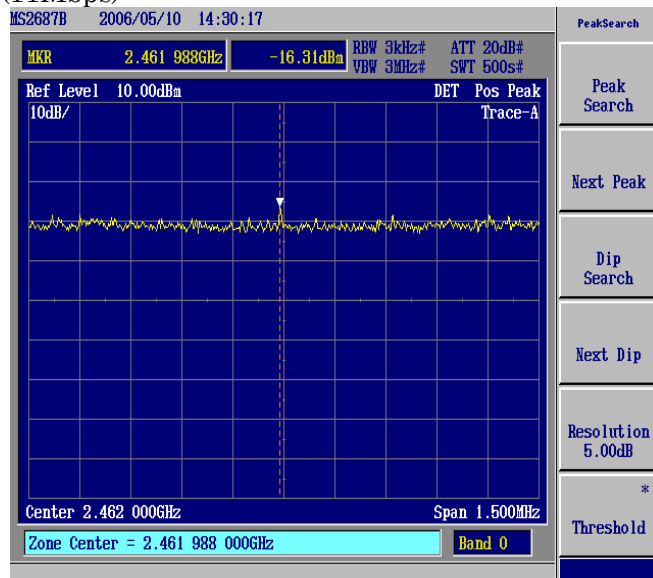

2412 MHz (1ch), OFDM (54Mbps)

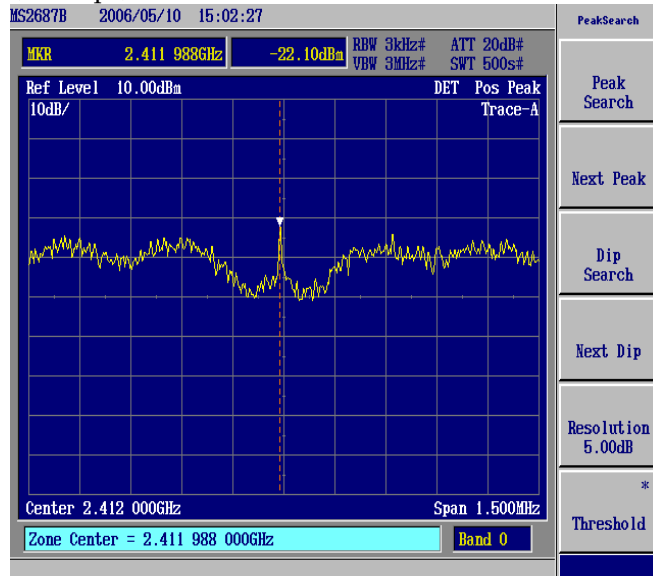

2437MHz (6ch), OFDM (54Mbps)



2462 MHz (11ch), OFDM (54Mbps)

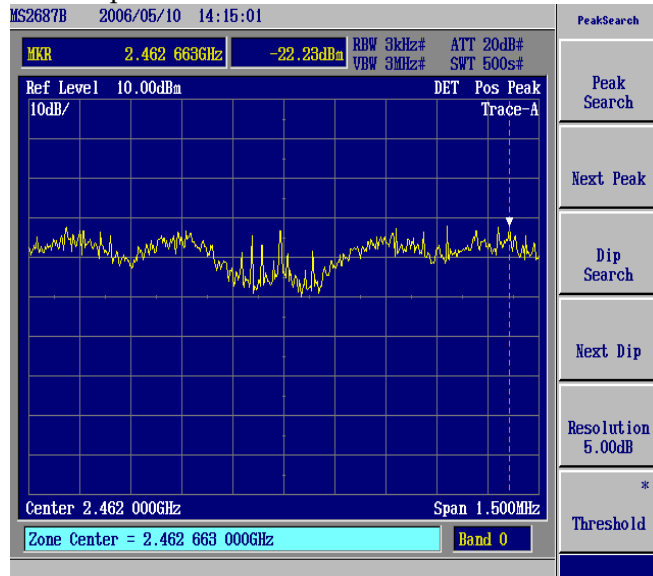

5.7 15. 247(c) Band Edge Measurement

5.7.1 Setting Remarks

- EUT directly connects to the spectrum analyzer via calibrated coaxial cable and 10 dB attenuator.
- The loss of the coaxial cable is maximum 1 dB.
- The emission at the band edge was measured by using the marker function of spectrum analyzer.
- The peak of the in-band emission was measured by using the marker to peak function of spectrum analyzer.
- This measurement was repeated in both side of the spectrum.
- The spectrum analyzer was set-up as following;

- ✓ Resolution bandwidth : 100 kHz
- ✓ Video bandwidth : > RBW
- ✓ Sweep : Auto
- ✓ Detector function : Peak
- ✓ Trace Mode : Max Hold

- Refer to test configuration figure 4.3.

5.7.2 Minimum Standard

In any 100kHz bandwidth outside the frequency band in which the transmitter is operating, emissions shall be at least 20 dB below the fundamental emission or shall not exceed the following field strength limits. Emissions falling in the restricted bands of 15.205 shall not exceed the following field strength limits:

Frequency of Emission (MHz)	Limit of the band edge spurious emission (dB μ V)	
	Peak	Average
Below 2,390.0		
Above 2,483.5	74	54

5.7.3 Result

EUT complies with the requirement.

Uncertainty of measurement result: ± 2.6 dB

Temperature, Humidity : 25 °C, 35%

5.7.4 Measured Data

The band edge emissions with Antenna No.1 are calculated as following;

(Band edge emission at the lower frequency 2,390 MHz in CCK modulation.)

$$\begin{aligned}
 P_{\max} / P_{\text{av}} &= 101.2 \text{ dB}\mu\text{V} / \text{m}, 76.2 \text{ dB}\mu\text{V} / \text{m} \\
 P_{\text{dev}} &= 44.47 \text{ dB} \\
 E_{\text{be}} &= 56.73 \text{ dB}\mu\text{V} / \text{m} \text{ (Margin: 17.27 dB)} \\
 E_{\text{av}} &= 31.73 \text{ dB}\mu\text{V} / \text{m} \text{ (Margin: 22.27 dB)}
 \end{aligned}$$

(Band edge emission at the higher frequency 2,483.5 MHz in CCK modulation.)

$$\begin{aligned}
 P_{\max} / P_{\text{av}} &= 103.0 \text{ dB}\mu\text{V} / \text{m}, 79.5 \text{ dB}\mu\text{V} / \text{m} \\
 P_{\text{dev}} &= 44.73 \text{ dB} \\
 E_{\text{be}} &= 58.27 \text{ dB}\mu\text{V} / \text{m} \text{ (Margin: 15.73 dB)} \\
 E_{\text{av}} &= 34.77 \text{ dB}\mu\text{V} / \text{m} \text{ (Margin: 19.23 dB)}
 \end{aligned}$$

(Band edge emission at the lower frequency 2,390 MHz in OFDM modulation.)

$$\begin{aligned}
 P_{\max} / P_{\text{av}} &= 104.1 \text{ dB}\mu\text{V} / \text{m}, 75.8 \text{ dB}\mu\text{V} / \text{m} \\
 P_{\text{dev}} &= 36.92 \text{ dB} \\
 E_{\text{be}} &= 67.18 \text{ dB}\mu\text{V} / \text{m} \text{ (Margin: 6.82 dB)} \\
 E_{\text{av}} &= 38.88 \text{ dB}\mu\text{V} / \text{m} \text{ (Margin: 15.12 dB)}
 \end{aligned}$$

(Band edge emission at the higher frequency 2,483.5 MHz in OFDM modulation.)

$$\begin{aligned}
 P_{\max} / P_{\text{av}} &= 105.7 \text{ dB}\mu\text{V} / \text{m}, 76.58 \text{ dB}\mu\text{V} / \text{m} \\
 P_{\text{dev}} &= 40.90 \text{ dB} \\
 E_{\text{be}} &= 64.80 \text{ dB}\mu\text{V} / \text{m} \text{ (Margin: 9.2 dB)} \\
 E_{\text{av}} &= 35.68 \text{ dB}\mu\text{V} / \text{m} \text{ (Margin: 18.32 dB)}
 \end{aligned}$$

- P_{\max} : Maximum peak power of the fundamental.
- P_{dev} : The amplitude delta between the peak power and the band edge emission.
- E_{be} : Band edge emission.
- E_{av} : Average of the band edge emission.

Lower frequency of the band edge 2,390.0 MHz, CCK (11Mbps)

	Ref Lvl	Delta 1 [T1]	RBW	RF Att	
	82 dBV	-44.47 dB	3 MHz	10 dB	
		-25.13026052 MHz	VBW		
			3 MHz		
			SWT	Unit	
			5 ms		dBV

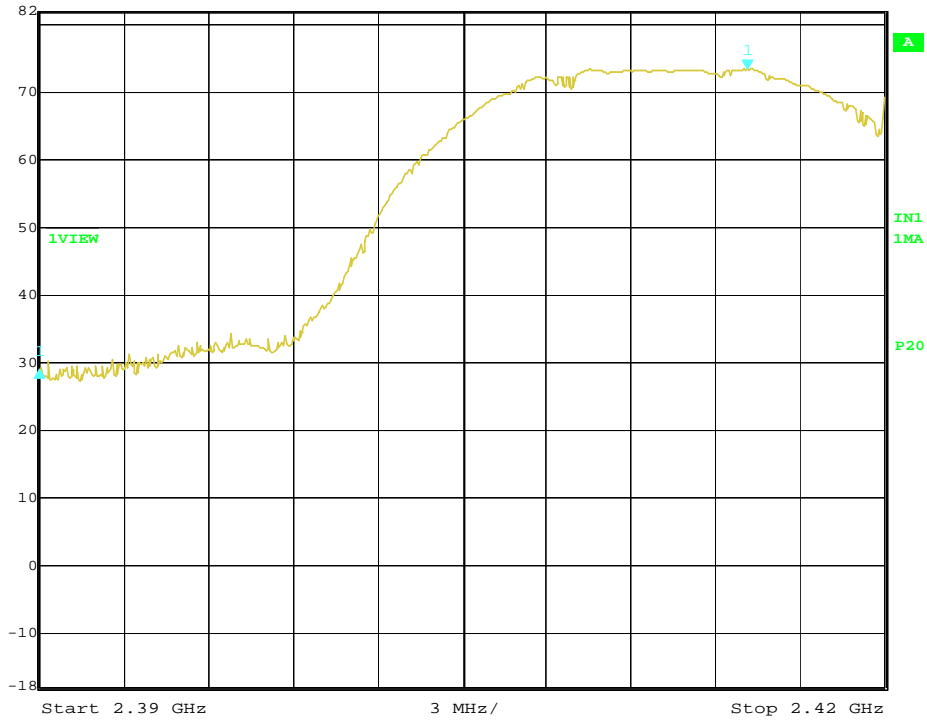

Date: 18.APR.2006 22:27:47

Higher frequency of the band edge 2,483.5 MHz, CCK (11Mbps)

	Ref Lvl	Delta 1 [T1]	RBW	RF Att	
	82 dBV	-44.73 dB	3 MHz	10 dB	
		24.04809619 MHz	VBW		
			3 MHz		
			SWT	Unit	
			5 ms		dBV

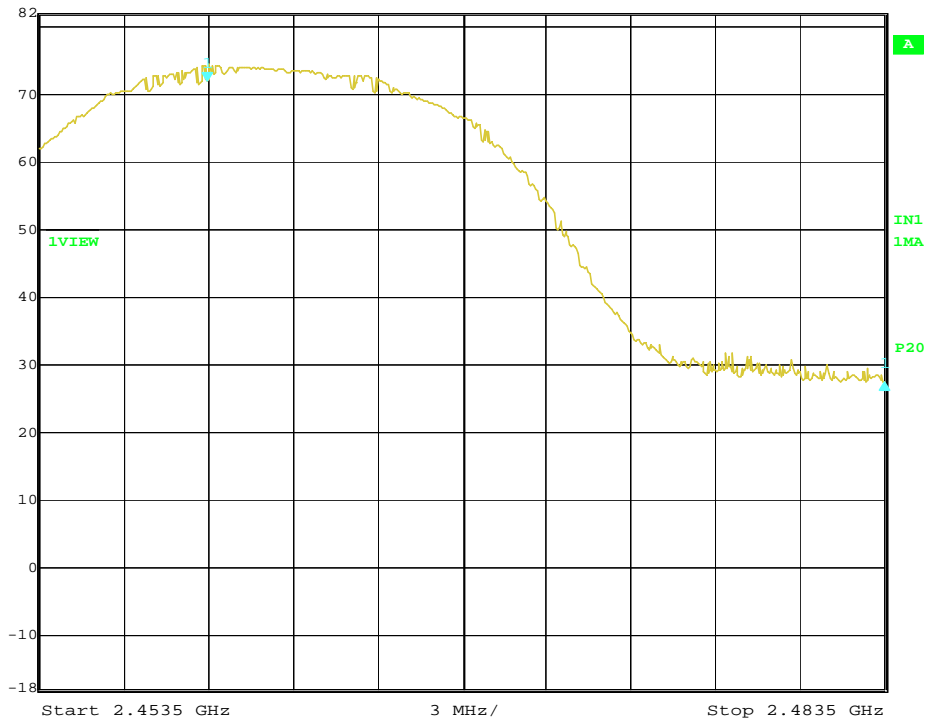

Date: 18.APR.2006 21:24:48

Lower frequency of the band edge 2,390.0 MHz, OFDM (54Mbps)

	Ref Lvl	Delta 1 [T1]	RBW	RF Att	20 dB
	90 dBV	-36.92 dB	3 MHz	VBW	3 MHz
		-27.29458918 MHz	SWT	5 ms	Unit
					dBV

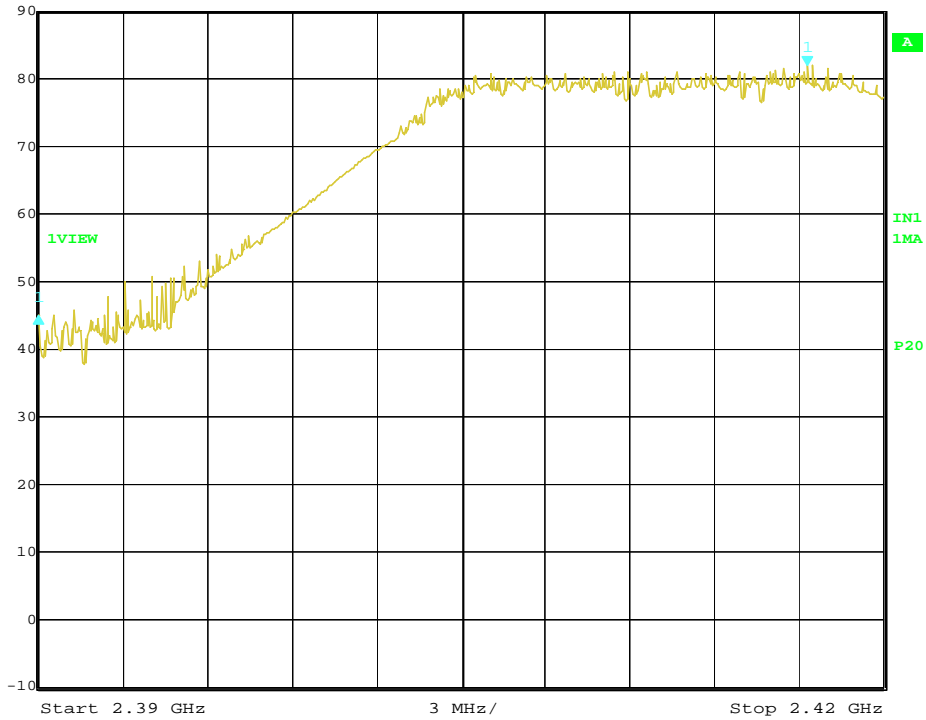

Date: 18.APR.2006 22:15:59

Higher frequency of the band edge 2,483.5 MHz, OFDM (54Mbps)

	Ref Lvl	Delta 1 [T1]	RBW	RF Att	20 dB
	90 dBV	-40.90 dB	3 MHz	VBW	3 MHz
		24.04809619 MHz	SWT	5 ms	Unit
					dBV

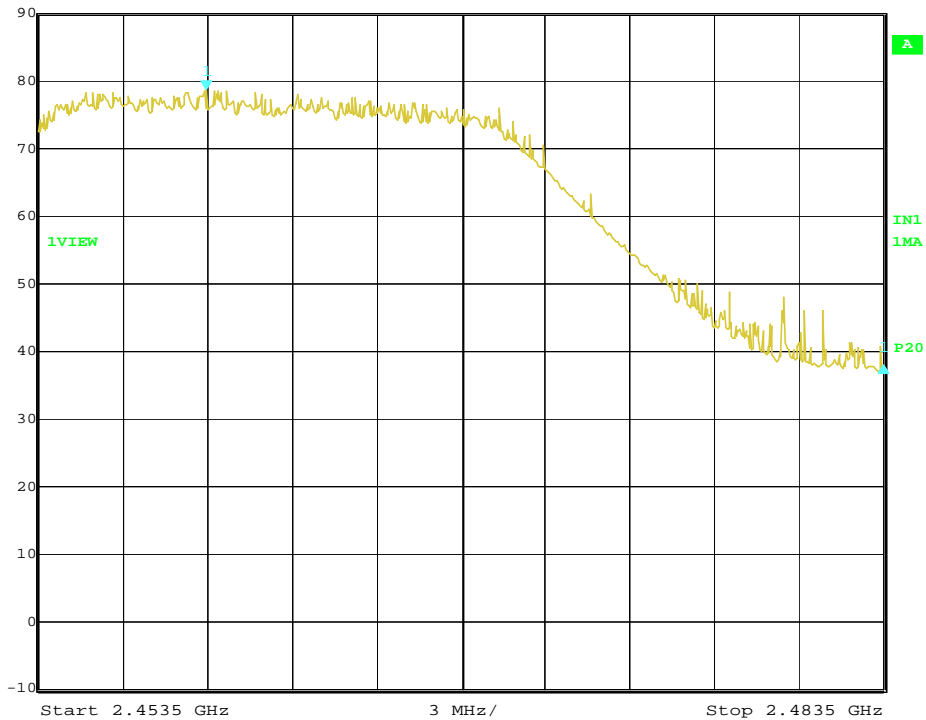

Date: 18.APR.2006 21:43:33

6. Photos

6.1 Setup Photo (Conducted Emission)

Front View

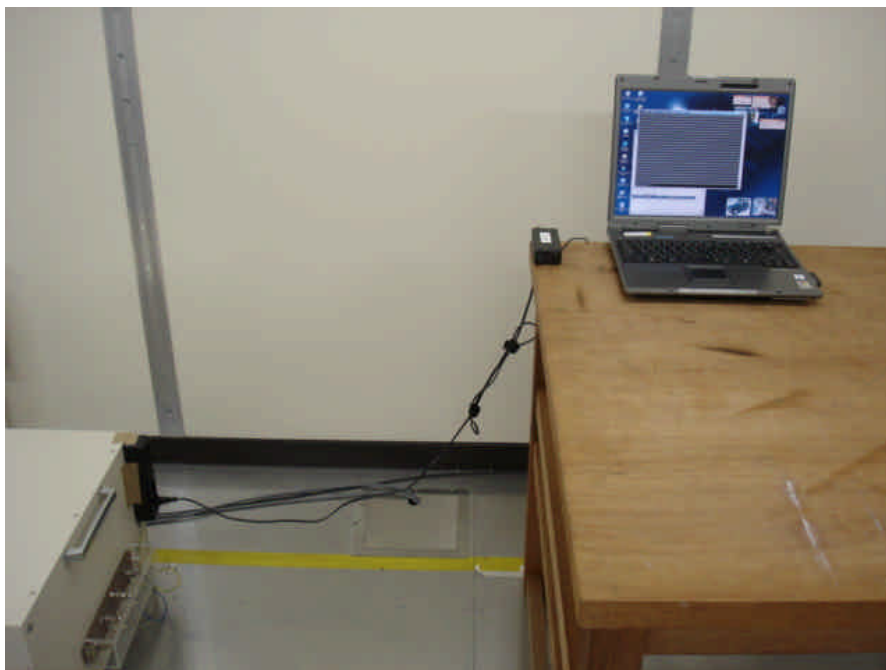

Side View



6.2 Setup Photo (Radiated Emission)

Front View



Rear View



7. List of Test Measurement Instruments

7.1 Conducted Emission

Instruments	Manufacturer	Model / Type	Serial No.	Calibration Date Next Calibration
Spectrum Analyzer	ADVANTEST CORPORATION	R3132	140501174	July, 2005 July, 2006
EMI Test Receiver	ROHDE & SCHWARZ	ESCS30	100335	May, 2005 May, 2006
Artificial-Mains Network	KYORITSU CORPORATION	KNW-341C (for EUT)	8-1659-1	September, 2005 September, 2006
Artificial-Mains Network	KYORITSU CORPORATION	KNW-244C (for Peripheral)	8-1657-1	September, 2005 September, 2006
Transient Limiter	AGILENT TECHNOLOGIES	11947A	3107A03745	July, 2005 July, 2006
RF Selector	Techno Science Japan Corp.	RFM-E221	3148	---
Spectrum Analyzer	ADVANTEST CORPORATION	R3132	140501174	July, 2005 July, 2006

7.2 Radiated Emission Measurement

Instruments	Manufacturer	Model / Type	Serial No.	Calibration Date Next Calibration
Programmable AC/DC Power Source	NF Corporation	ES18000W	425779	---
EMI Test Receiver	ROHDE & SCHWARZ	ESIB40	100211	April, 2005 April, 2006
Biconical Antenna (30 to 300MHz)	SCHWARZBECK	VHBB9124(Balun) BBA9106(Elements)	311	September, 2005 September, 2006
Log.-Periodic Antenna (300 MHz to 1 GHz)	SCHWARZBECK	UHALP 9108 A	645	September, 2005 September, 2006
Horn Antenna	SCHWARZBECK	BBHA 9120 D	446	September, 2005 September, 2006
Horn Antenna	ETS LINDGREN	3160-08	00033778	September, 2005 September, 2006
Horn Antenna	ETS LINDGREN	3160-09	00034723	September, 2005 September, 2006

7.3 Conducted Radio Measurement

Instruments	Manufacturer	Model / Type	Serial No.	Calibration Date Next Calibration
DC Power Source	Diamond Antenna	GSV3000	01101481	---
Spectrum Analyzer	Anritsu	MS2687B	620016270 6	April, 2006 April, 2007
Signal Generator	Agilent Technology	E8254A	US411401 86	June, 2005 June, 2006
Oscilloscope	Tektronix	TDS794D	B031832	June, 2005 June, 2006
Diode Detector	Agilent Technology	423B	MY422418 36	March, 2006 March, 2007