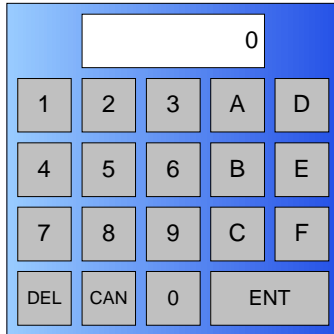


**Figure 5-58: Alphanumeric Keypad**



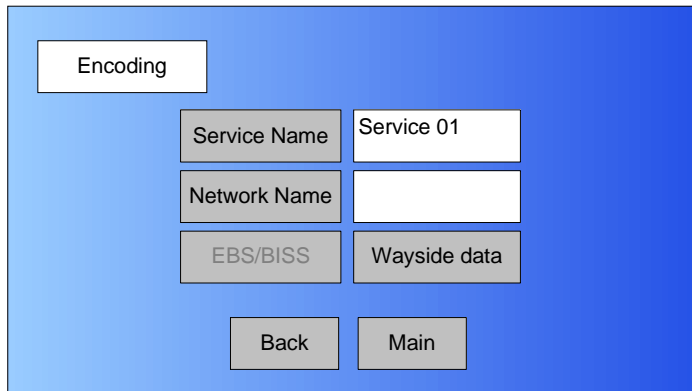
---

**Note** When the **Encryption** screen is displayed in the following step and the encryption key is entered, the actual encryption key will not be displayed.

---

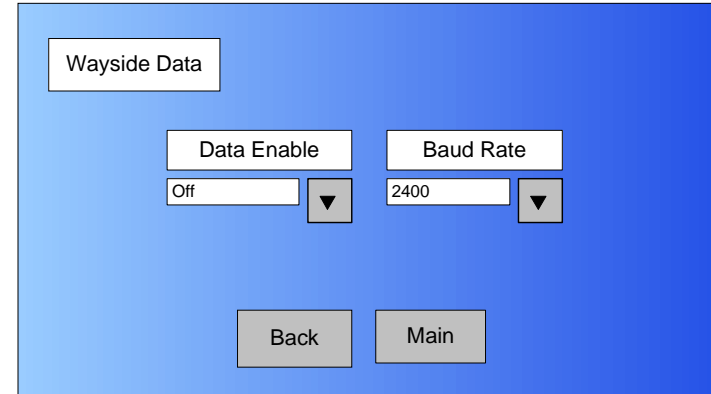
- 86. Enter your encryption key, select the **ENT** key, and observe the **Encryption** screen is displayed.
- 87. Select the **Back** option button and observe the **Encoding** screen is displayed. See Figure 5-59.

**Figure 5-59: Encoding Screen - Typical**



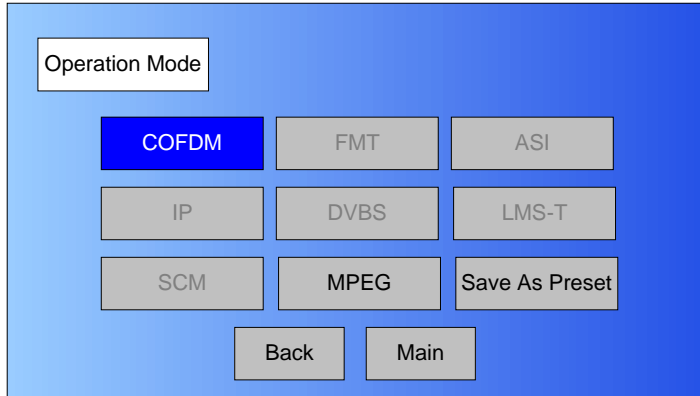
- 88. Select the **Wayside data** option button and observe the **Wayside Data** screen is displayed. See Figure 5-60.

**Figure 5-60: Wayside Data Screen - Typical**



- 89. Select the **Data Enable** pull-down menu and select the **Off**, **TTV Format**, **CJM2 Format**, or **Low Delay CJM2** option, as required.
- 90. Select the **Baud Rate** pull-down menu and select the **1200**, **2400**, **4800**, **9600**, **19200**, or **38400** option, as required.
- 91. Select the **Submit** option button.
- 92. Select the **Back** option button and observe the **Encoding** screen is displayed.
- 93. Select the **Back** option button and observe the **MPEG** screen is displayed.
- 94. Select the **Back** option button and observe the **Operation Mode** screen is displayed. See Figure 5-61 on page 5-28.

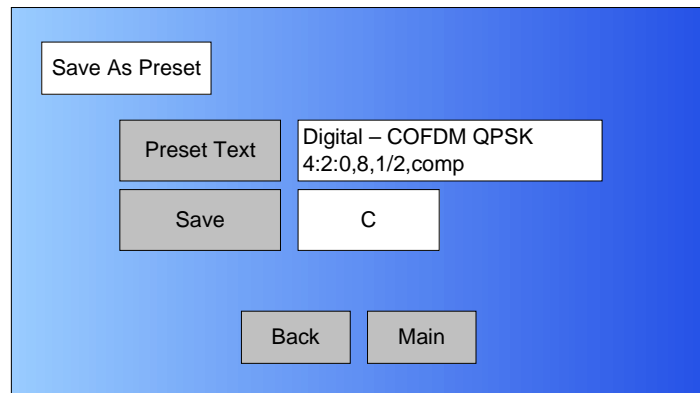
**Figure 5-61: Operation Mode Screen**



**Note** When the **Save As Preset** screen is displayed in the following step, the **Preset Text** and **Save** text boxes will display the name and identification of the digital COFDM Preset currently being used as the digital COFDM “make-from” for this custom Preset.

95. Select the **Save As Preset** option button and observe the **Save As Preset** screen is displayed. See [Figure 5-62](#).

**Figure 5-62: Save As Preset Screen - Typical**

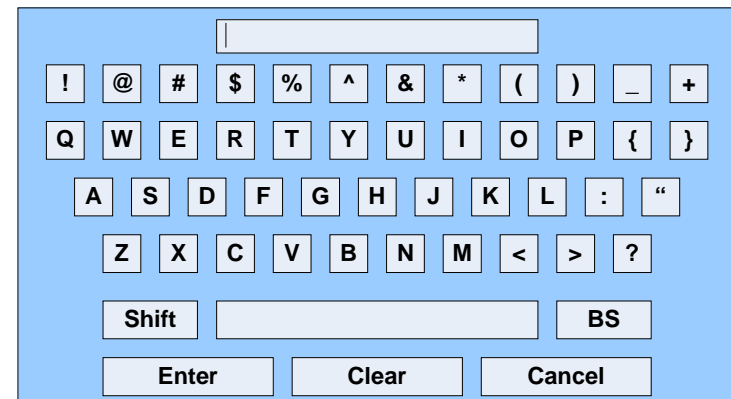


**Notes** In the following steps, if a factory default digital COFDM Preset was used as a “make-from” to prepare this custom Preset, the **Preset Text** text box and the **Save** text box **must be** changed. **You cannot change or overwrite any factory default Presets!**

If a custom digital COFDM Preset was used as a “make-from” to prepare this custom Preset, a brief description of the custom Preset must be entered in the **Preset Text** text box for easy identification purposes.

96. Select the **Preset Text** option button and observe that the keyboard screen is displayed. See [Figure 5-63](#).

**Figure 5-63: Keyboard Screen**



97. Enter a unique digital COFDM Preset description, as required, and select the **Enter** key.
98. Observe the **Save As Preset** screen is displayed and the **Preset Text** text box displays the Preset description.

---

**Notes** When saving the new custom digital Preset in the following step, the Preset number will automatically be increased to the next available Preset number to avoid overwriting an existing Preset.

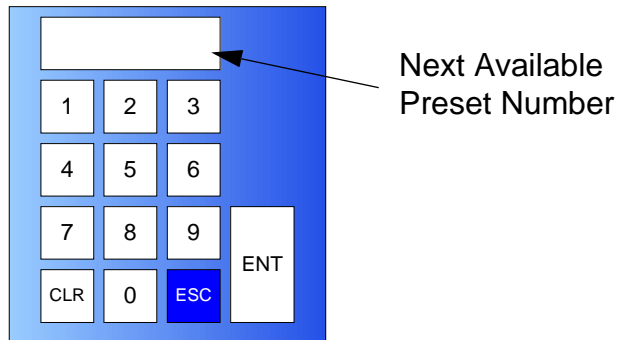
If you wish to overwrite the existing Preset number (unless it is a factory default Preset), enter the Preset number to be overwritten. A warning message will be displayed asking “**Are you sure?**”. Select the **Yes** option button.

Once an existing custom Preset is overwritten, it cannot be recovered. It must be re-entered from scratch.

---

99. Select the **Save** option button and observe the numeric keypad is displayed. See [Figure 5-64](#).

**Figure 5-64: Numeric Keypad - Typical**



---

**Notes** When saving Presets in the following steps, **Preset A** thru **Preset J** are factory default Presets. The factory default Preset numbers cannot be changed.

---

---

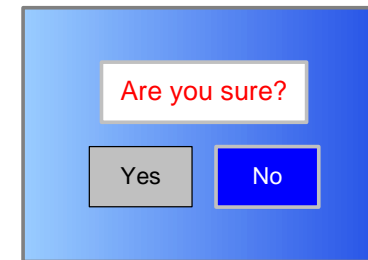
**Notes** To change the default Preset number, perform [step 100](#) and go to [step 101](#).

To accept the next available Preset number, go to [step 101](#)

---

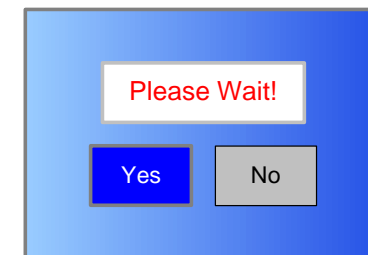
100. Select the **CLR** key and enter the Preset number required.
101. Select the **ENT** key and observe the **Are you sure?** confirmation screen is displayed. See [Figure 5-65](#).

**Figure 5-65: Confirmation Screen**



102. Select the **YES** option button and observe the **Please Wait!** message box is displayed. See [Figure 5-66](#).

**Figure 5-66: Please Wait Message Box**



103. After a short delay, observe the **Save As Preset** screen is displayed.
-

104. Select the **Main** option button and observe the Main screen is displayed.

### 5.4.3 Create or Update Digital ASI Preset Configuration Settings in Local Mode

The procedure required to create a new custom digital ASI Preset configuration or to update an existing digital ASI Preset configuration is contained in the following steps.

When preparing a new digital ASI Preset, you must first select an existing digital ASI Preset from either the ASI factory default Preset or from your own custom digital ASI Presets. The selected digital ASI Preset will be used as a “make-from” to prepare the new digital ASI Preset configuration.

Please note that while the ASI factory default Preset may be used to prepare a new Preset configuration, the **factory default Preset cannot be changed or deleted**. It can only be used as a “make-from”.

When the new configuration is prepared using the factory default Preset, it cannot be saved with the factory Preset number or Preset name. A new Preset number and Preset name must be assigned to the new Preset.

When using a custom Preset as a “make-from”, the new Preset should be saved with a new Preset number. When you save the new Preset, the Preset number will automatically be increased to the next available Preset number. If you select an existing Preset number when saving the new Preset, the original custom Preset will be overwritten and cannot be recovered. The only way to restore a Preset that has been overwritten is to re-enter the custom Preset data from scratch.

If you are updating configuration settings on an existing custom Preset, when you save the configuration settings, the Preset

number will automatically be increased to the next available Preset number. You must enter and save the configuration settings using the original Preset number.

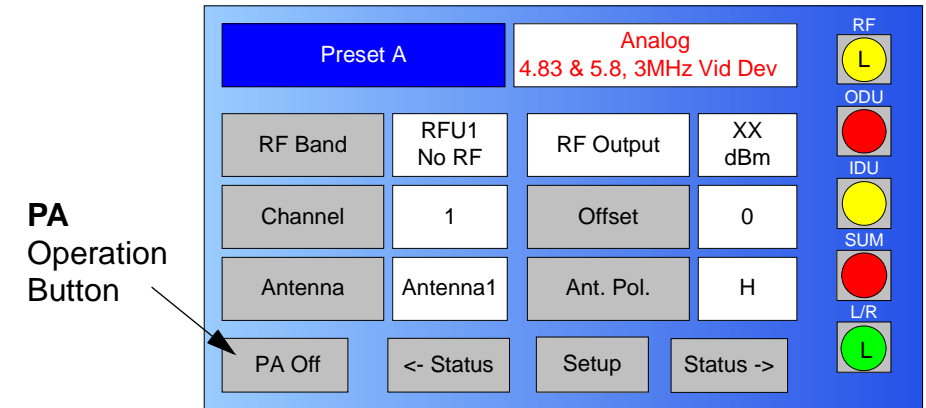
---

**Note** In the following steps, the color LCD display option buttons and pull-down menu options may be selected using either the touch screen or the function keys and the **SEL** key.

---

1. Verify the MTX5000 IDU is powered up. See ["Powering the MTX5000 System" on page 3-7](#).
2. Observe the Main screen is displayed. See [Figure 5-67](#).

**Figure 5-67: Main Screen - Typical**



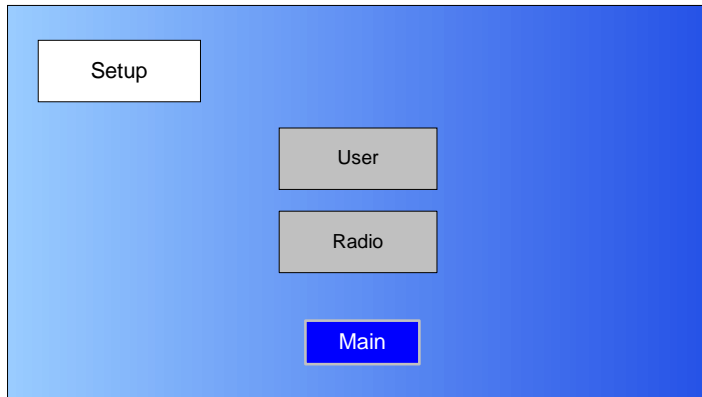
3. Select the **L/R** option button for **L** (local mode), as required.

**Notes** If you are updating an existing digital ASI Preset configuration, select the Preset to be updated in the following step.

If you are creating a new digital ASI Preset configuration, any digital ASI Preset may be selected in the following step.

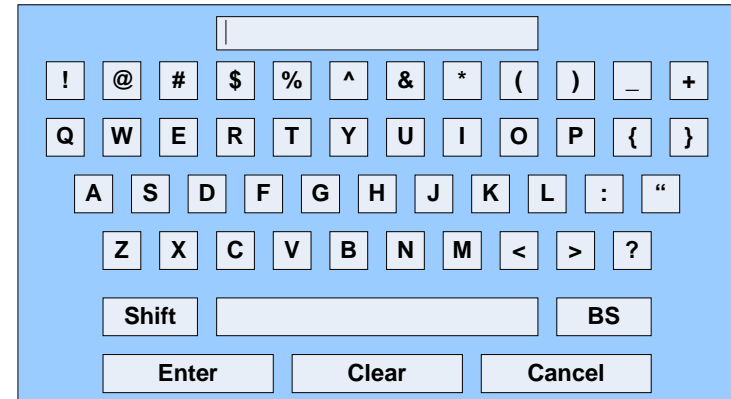
4. Perform “[Select Preset](#)” on [page 3-24](#) to select the digital ASI Preset required to be updated or to be used as a “make-from”.
5. Select the Main screen **PA** operation button for **PA Off**, as required.
6. Select the Main screen **Setup** option button and observe the **Setup** screen is displayed. [See Figure 5-68](#).

**Figure 5-68: Setup Screen**



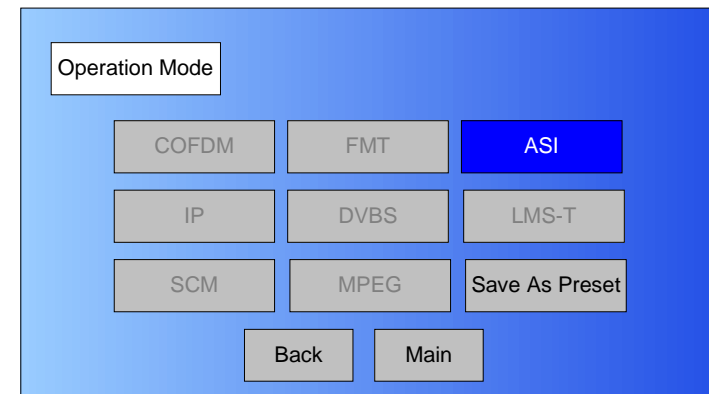
7. Select the **User** option button and observe the keyboard screen is displayed. [See Figure 5-69](#).

**Figure 5-69: Keyboard Screen**



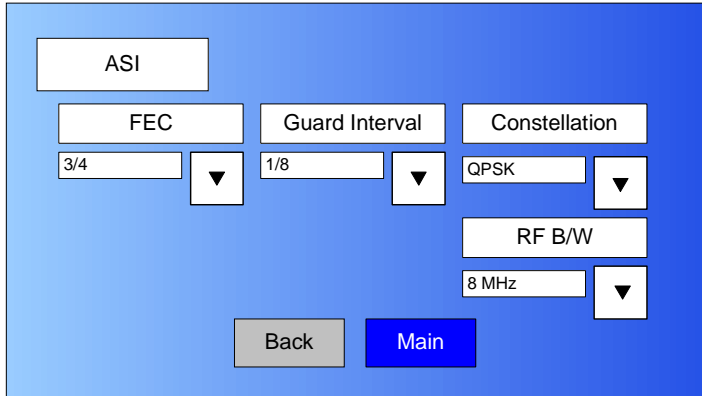
8. Enter your password, select the **Enter** key, and observe the **Operation Mode** screen is displayed. [See Figure 5-70](#).

**Figure 5-70: Operation Mode Screen**



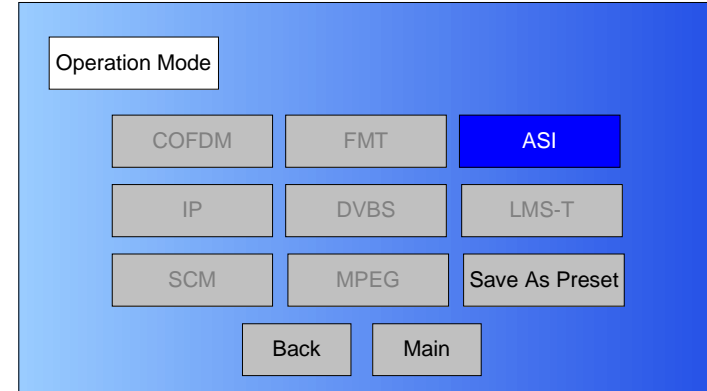
9. Select the **ASI** option button and observe the **ASI** screen is displayed. [See Figure 5-71 on page 5-32](#).

Figure 5-71: ASI Screen - Typical



10. Select the **FEC** pull-down menu and select the **1/2**, **2/3**, **3/4**, **5/6**, or **7/8** option, as required.
11. Select the **Guard Interval** pull-down menu and select the **1/32**, **1/16**, **1/8**, or **1/4** option, as required.
12. Select the **Constellation** pull-down menu and select **QPSK**, **16-QAM**, or **64-QAM**, as required.
13. Select the **RF B/W** pull-down menu and select **6 MHZ**, **7 MHZ**, or **8 MHZ**, as required.
14. Select the **Back** option button and observe the **Operation Mode** screen is displayed. See [Figure 5-72](#).

Figure 5-72: Operation Mode Screen



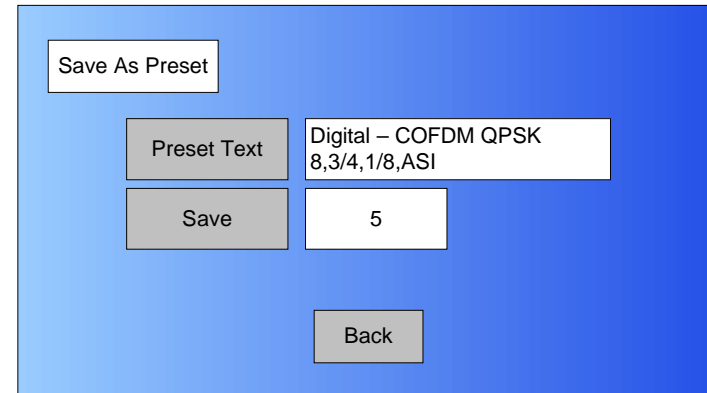
---

**Note** When the **Save As Preset** screen is displayed in the following step, the **Preset Text** and **Save** text boxes will display the name and identification of the digital ASI Preset currently being used as the digital ASI “make-from” for this custom Preset.

---

15. Select the **Save As Preset** option button and observe the **Save As Preset** screen is displayed. See [Figure 5-73](#).

Figure 5-73: Save As Preset Screen - Typical



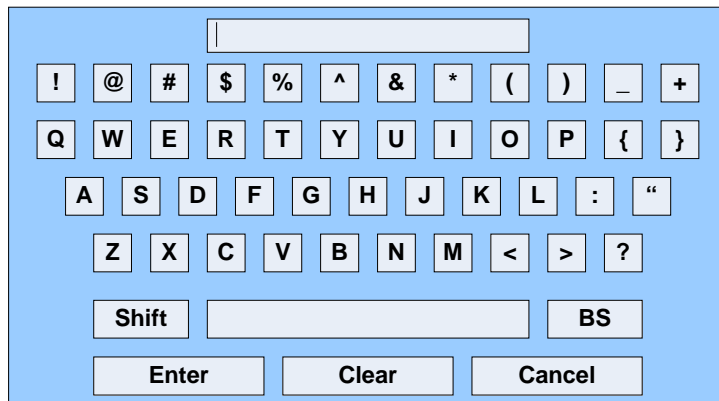
---

**Notes** In the following steps, if a factory default digital ASI Preset was used as a “make-from” to prepare this custom Preset, the **Preset Text** text box and **Save** text box *must be* changed. **You cannot change or overwrite any factory default Presets!**

If a custom digital ASI Preset was used as a “make-from” to prepare this custom Preset, a brief description of the custom Preset must be entered in the **Preset Text** text box for easy identification purposes.

- 
16. Select the **Preset Text** option button and observe that the keyboard screen is displayed. See [Figure 5-74](#).

**Figure 5-74: Keyboard Screen**



17. Enter a unique digital ASI Preset description, as required, and select the **Enter** key.
18. Observe the **Save As Preset** screen is displayed and the **Preset Text** text box displays the Preset description.

---

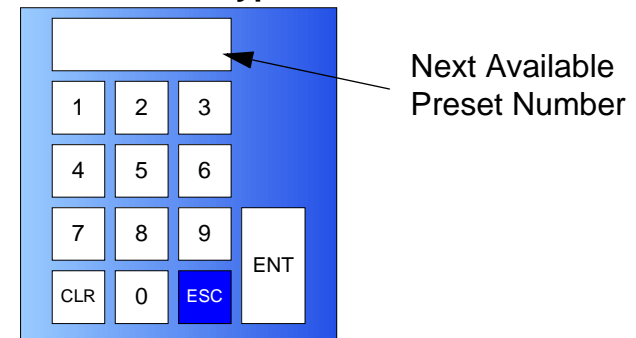
**Notes** When saving the new custom digital ASI Preset in the following step, the Preset number will automatically be increased to the next available Preset number to avoid overwriting an existing Preset.

If you wish to overwrite the existing Preset number (unless it is a factory default Preset), enter the Preset number to be overwritten. A warning message will be displayed asking “**Are you sure?**”. Select the **Yes** option button.

Once an existing custom Preset is overwritten, it cannot be recovered. It must be re-entered from scratch.

- 
19. Select the **Save** option button and observe the numeric keypad is displayed. See [Figure 5-75](#).

**Figure 5-75: Numeric Keypad**



---

**Notes** When saving Presets in the following steps, **Preset A** thru **Preset J** are factory default Presets. The factory default Preset numbers cannot be changed.

---

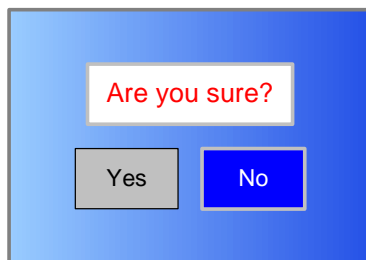
**Notes** To change the default Preset number, perform [step 20](#) and go to [step 21](#).

To accept the next available Preset number, go to [step 21](#)

---

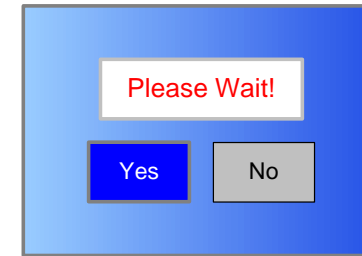
20. Select the **CLR** key and enter the Preset number required.
21. Select the **ENT** key and observe the **Are you sure?** confirmation screen is displayed. [See Figure 5-76](#).

**Figure 5-76: Confirmation Screen**



22. Select the **YES** option button and observe the **Please Wait!** message box is displayed. [See Figure 5-77](#).

**Figure 5-77: Please Wait Message Box**



23. After a short delay, observe the **Save As Preset** screen is displayed.
24. Select the **Main** option button and observe the Main screen is displayed.

#### 5.4.4 Create or Update Digital LMS-T Preset Configuration Settings in Local Mode

The procedure required to create a new custom digital LMS-T Preset configuration or to update an existing digital LMS-T Preset configuration is contained in the following steps.

When preparing a new digital LMS-T Preset, you must first select an existing digital LMS-T Preset from either the digital LMS-T factory default Preset or from your own custom digital LMS-T Presets. The selected Preset will be used as a “make-from” to prepare the new digital LMS-T Preset configuration.

Please note that while factory default Presets may be used to prepare a new Preset configuration, these **factory default Presets cannot be changed or deleted**. They can only be used as “make-froms”.

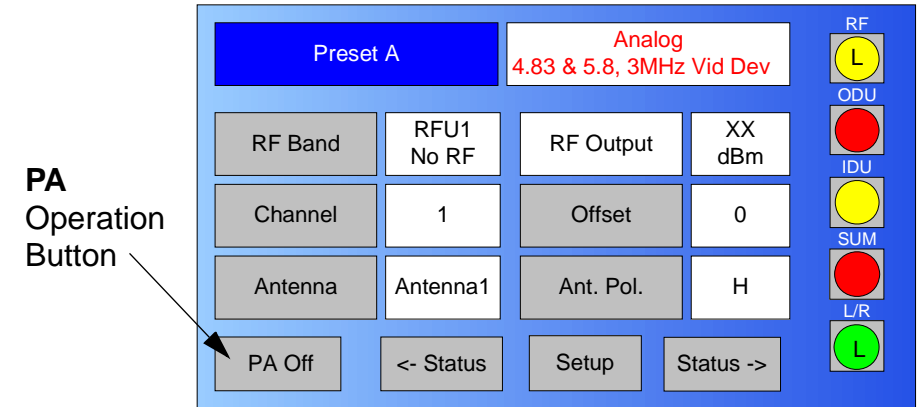
When the new configuration is prepared using the factory default Preset, it cannot be saved with the factory Preset number or Preset name. A new Preset number and Preset name must be assigned to the new Preset.



When using a custom Preset as a “make-from”, the new Preset should be saved with a new Preset number. When you save the new Preset, the Preset number will automatically be increased to the next available Preset number. If you select an existing Preset number when saving the new Preset, the original custom Preset will be overwritten and cannot be recovered. The only way to restore a Preset that has been overwritten is to re-enter the custom Preset data from scratch.

If you are updating configuration settings on an existing custom Preset, when you save the configuration settings, the Preset number will automatically be increased to the next available Preset number. You must enter and save the configuration settings using the original Preset number.

**Figure 5-78: Main Screen - Typical**



3. Select the **L/R** option button for **L** (local mode), as required.

**Notes** If you are updating an existing digital LMS-T Preset configuration, select the Preset to be updated in the following step.

If you are creating a new digital LMS-T Preset configuration, any digital LMS-T Preset may be selected in the following step.

4. Perform “[Select Preset](#)” on page 3-24 to select the digital LMS-T Preset required to be updated or to be used as a “make-from”.
5. Select the Main screen **PA** operation button for **PA Off**, as required.
6. Select the Main screen **Setup** option button and observe the **Setup** screen is displayed. See [Figure 5-79](#) on page 5-36.

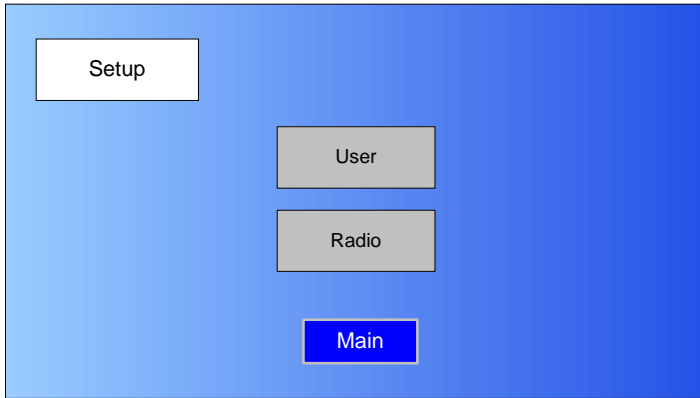
---

**Note** In the following steps, the color LCD display option buttons and pull-down menu options may be selected using either the touch screen or the function keys and the **SEL** key.

---

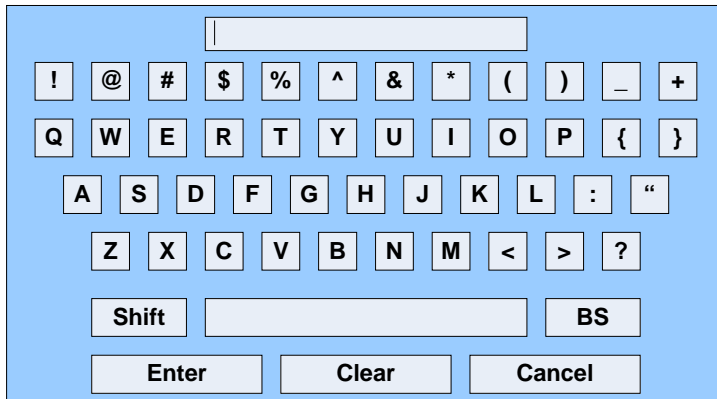
1. Verify the MTX5000 IDU is powered up. See [“Powering the MTX5000 System”](#) on page 3-7.
2. Observe the Main screen is displayed. See [Figure 5-78](#).

Figure 5-79: Setup Screen



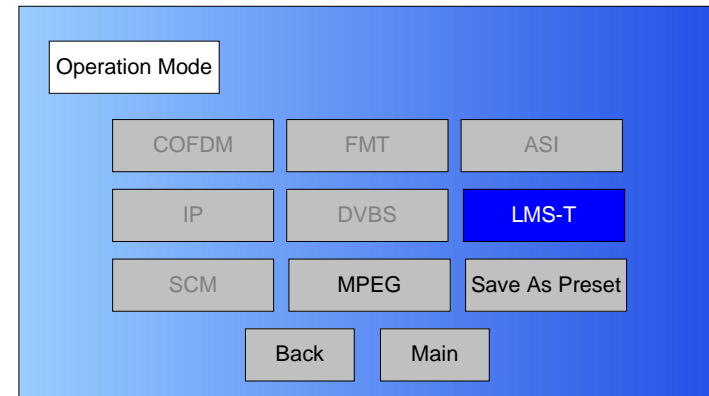
7. Select the **User** option button and observe the keyboard screen is displayed. See Figure 5-80.

Figure 5-80: Keyboard Screen



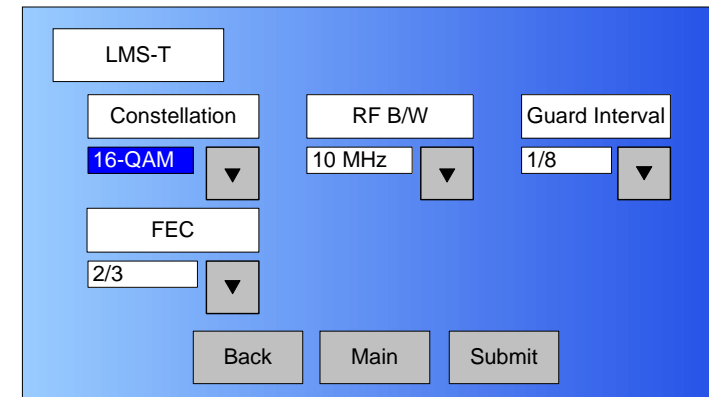
8. Enter your password, select the **Enter** key, and observe the **Operation Mode** screen is displayed. See Figure 5-81.

Figure 5-81: Operation Mode Screen



9. Select the **LMS-T** option button and observe the **LMS-T** screen is displayed. See Figure 5-82.

Figure 5-82: LMS-T Screen - Typical



10. Use the **Constellation** pull-down menu to select **QPSK** or **16-QAM**, as required.

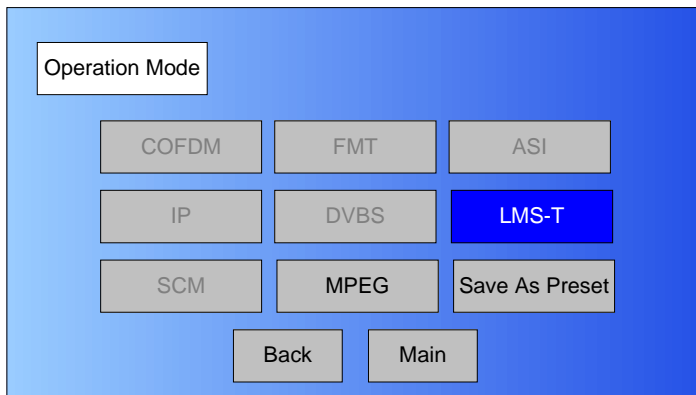
---

**Note** In the following step, **2/3** is the only LMS-T FEC option available.

---

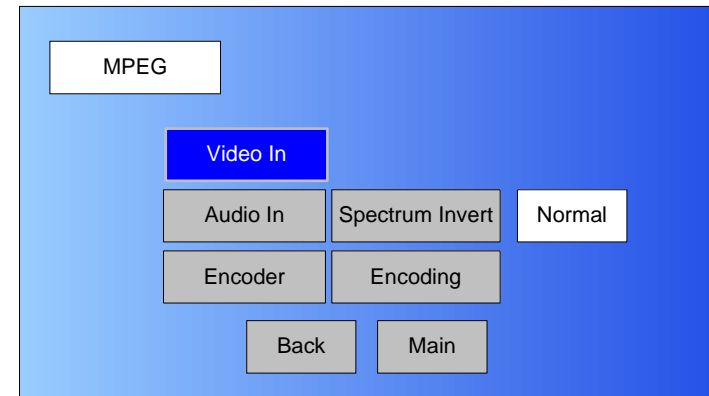
11. Observe the **FEC** (Forward Error Correction) pull-down menu indicates **2/3**.
12. Use the **RF B/W** pull-down menu to select **10 MHZ** or **20 MHZ**, as required.
13. Use the **Guard Interval** pull-down menu and select **1/16** or **1/8**, as required.
14. Select the **Submit** option button.
15. Select the **Back** option button and observe the **Operation Mode** screen is displayed. See Figure 5-83.

**Figure 5-83: Operation Mode Screen**



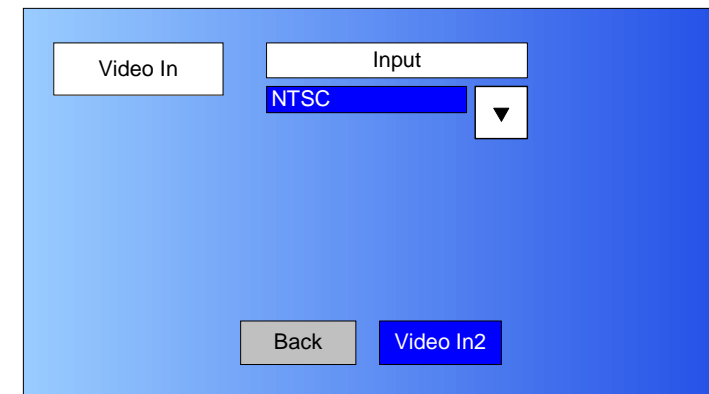
16. Select the **MPEG** option button and observe the **MPEG** screen is displayed. See Figure 5-84.

**Figure 5-84: MPEG Screen - Typical**



17. Select the **Video In** option button and observe the **Video In** screen is displayed. See Figure 5-85.

**Figure 5-85: Video In Screen 1 - Typical**



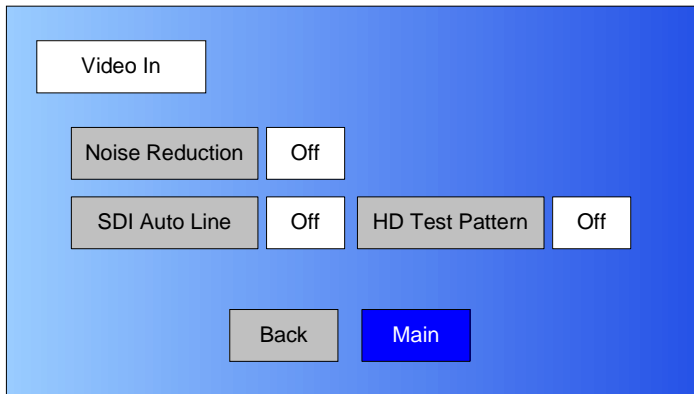

---

**Note** In the following step, select an **Input** option applicable to the licensed options contained in your MTX5000 IDU only. Selection of an option that is not licensed in your radio will cause the IDU to operate in the NTSC default mode.

---

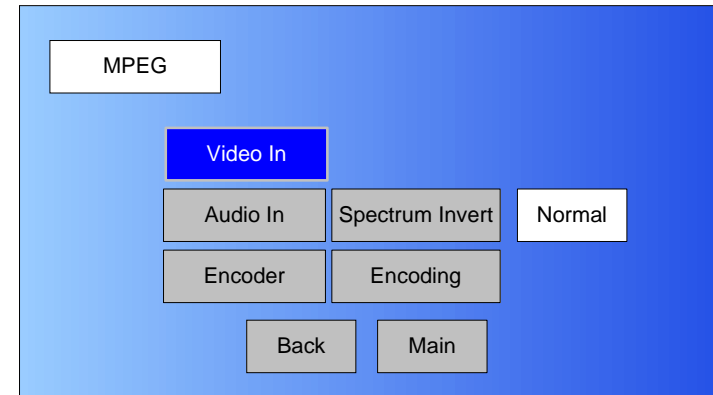
18. Use the **Input** pull-down menu to select the video input option required.
19. Select the **Video In2** option button and observe the **Video In** screen 2 is displayed. See Figure 5-86.

**Figure 5-86: Video In Screen 2 - Typical**



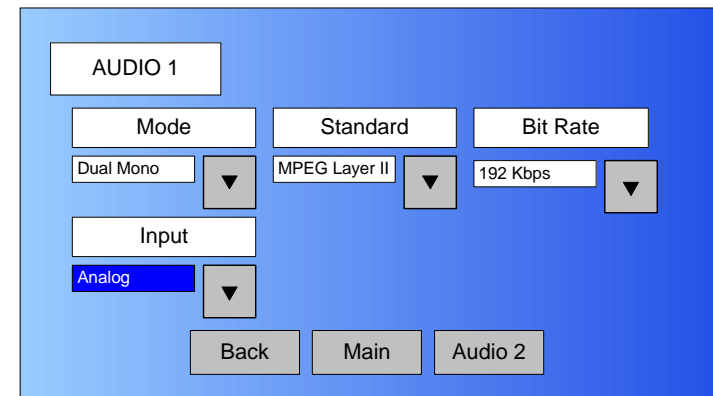
20. Select the **Noise Reduction** option button for **On** or **Off**, as required.
21. Select the **SDI Auto Line** option button for **On** or **Off**, as required.
22. Select the **HD Test Pattern** option button for **On** or **Off**, as required.
23. Select the **Back** option button and observe the **Video In** screen is displayed.
24. Select the **Back** option button and observe the **MPEG** screen is displayed. See Figure 5-87.

**Figure 5-87: MPEG Screen - Typical**



25. Select the **Audio In** option button and observe the **AUDIO 1** screen is displayed. See Figure 5-88.

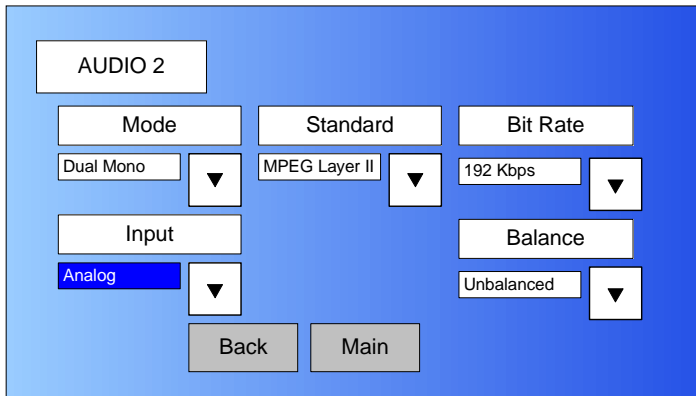
**Figure 5-88: AUDIO 1 Screen - Typical**



26. Use the **Mode** pull-down menu to select **Stereo** or **Dual Mono**, as required.
27. Use the **Standard** pull-down menu to select **Off**, **MPEG Layer II**, **Linear PCM**, or **MPEG Layer I**, as required.

28. Use the **Bit Rate** pull-down menu to select **128 Kbps**, **160 Kbps**, **192 Kbps**, **224 Kbps**, **256 Kbps**, **320 Kbps**, or **384 Kbps**, as required.
29. Use the **Input** pull-down menu to select **Test Tone**, **Analog**, or **SDI Emb**, as required.
30. Select the **Audio 2** option button and observe the **AUDIO 2** screen is displayed. See Figure 5-89.

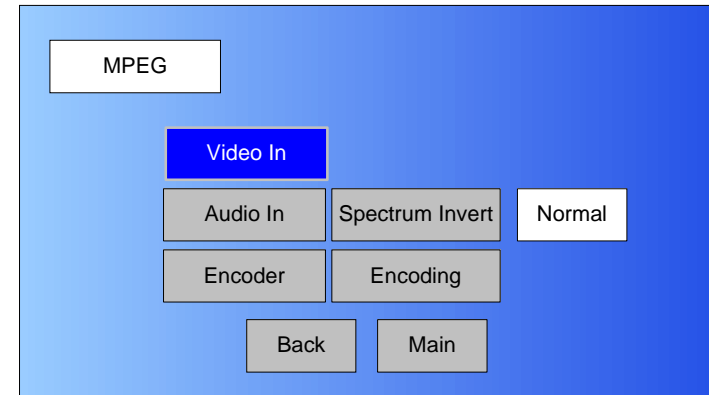
**Figure 5-89: AUDIO 2 Screen - Typical**



31. Use the **Mode** pull-down menu to select **Stereo** or **Dual Mono**, as required.
32. Use the **Standard** pull-down menu to select **Off**, **MPEG Layer II**, **Linear PCM**, or **MPEG Layer I**, as required.
33. Use the **Bit Rate** pull-down menu to select **128 Kbps**, **160 Kbps**, **192 Kbps**, **224 Kbps**, **256 Kbps**, **320 Kbps**, or **384 Kbps**, as required.
34. Use the **Input** pull-down menu to select **Test Tone**, **Analog**, **SDI Emb**, **AES-EBU**, or **Channel Ide**, as required.
35. Select the **Back** option button and observe the **AUDIO 1** screen is displayed.

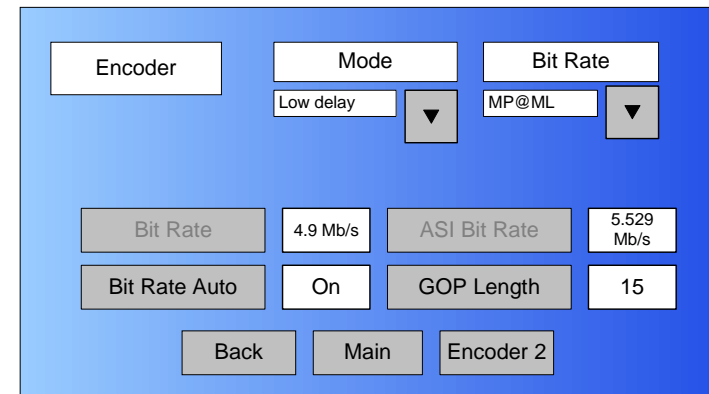
36. Select the **Back** option button and observe the **MPEG** screen is displayed. See Figure 5-90.

**Figure 5-90: MPEG Screen - Typical**



37. Select the **Spectrum Invert** option button to select **Normal** or **Inverted**, as required.
38. Select the **Encoder** option button and observe the **Encoder** screen is displayed. See Figure 5-91.

**Figure 5-91: Encoder Screen - Typical**



39. Select the **Mode** pull-down menu and select **Standard** or **Low delay**, as required.
40. Select the **Bit Rate** pull-down menu and select **MP@ML** or **422P@ML**, as required.

---

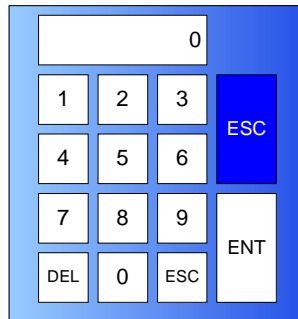
**Notes** In the following step, if the **Bit Rate Auto** option button selected is **On**, the **Bit Rate** option button will be inactive (greyed out). Go to [step 43](#).

If the **Bit Rate Auto** option button selected is **Off**, the **Bit Rate** option button will be active. Go to [step 42](#).

---

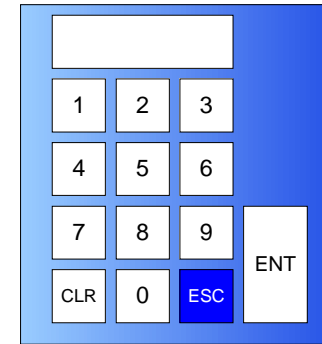
41. Select the **Bit Rate Auto** option button for **Off** or **On**, as required.
42. Observe the **Bit Rate** option button is active. Select the **Bit Rate** option button and observe the numeric keypad is displayed. [See Figure 5-92](#).

**Figure 5-92: Numeric Keypad**



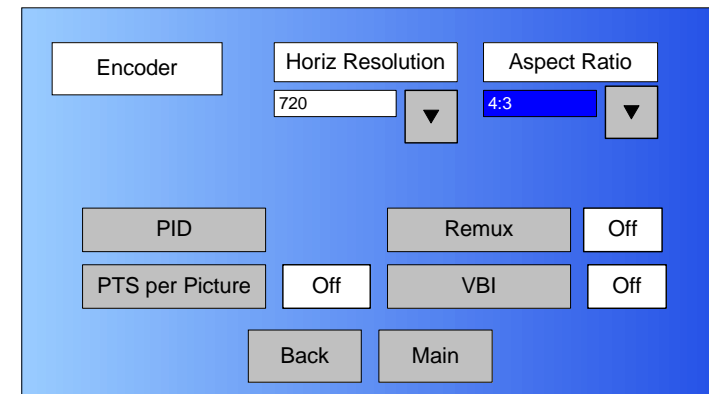
43. Enter the bit rate required, select the **ENT** key, and observe the **Encoder** screen is displayed.
44. Select the **GOP Length** option button and observe the numeric keypad is displayed. [See Figure 5-93](#).

**Figure 5-93: Numeric Keypad**



45. Enter the Group of Pictures (GOP) number required, select the **ENT** key, and observe the **Encoder** screen is displayed.
46. Select the **Encoder 2** option button and observe the **Encoder** screen is displayed. [See Figure 5-94](#).

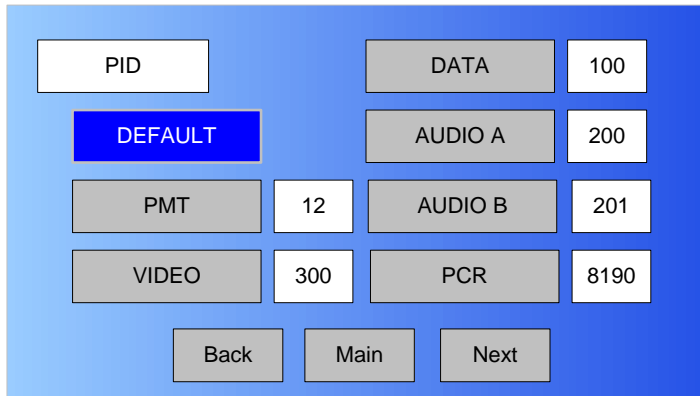
**Figure 5-94: Encoder Screen 2 - Typical**



47. Select the **Horiz Resolution** pull-down menu and select **720**, **704**, **544**, **528**, **480**, or **352**, as required.
48. Select the **Aspect Ratio** pull-down menu and select **4:3** or **16:9**, as required.

49. Select the **PID** option button and observe the **PID** screen is displayed. See [Figure 5-95](#).

**Figure 5-95: PID Screen - Typical**



56. Enter the **PMT** PID required, select the **ENT** key, and observe the **PID** screen is displayed.
57. Select the **AUDIO B** option button and observe the numeric keypad is displayed.
58. Enter the **AUDIO B** PID required, select the **ENT** key, and observe the **PID** screen is displayed.
59. Select the **VIDEO** option button and observe the numeric keypad is displayed.
60. Enter the **Video** PID required, select the **ENT** key, and observe the **PID** screen is displayed.
61. Select the **PCR** option button and observe the numeric keypad is displayed.
62. Enter the **PCR** PID required, select the **ENT** key, and observe the **PID** screen is displayed.
63. Select the **Next** option button and observe the **PID-2** screen is displayed. See [Figure 5-96](#).

---

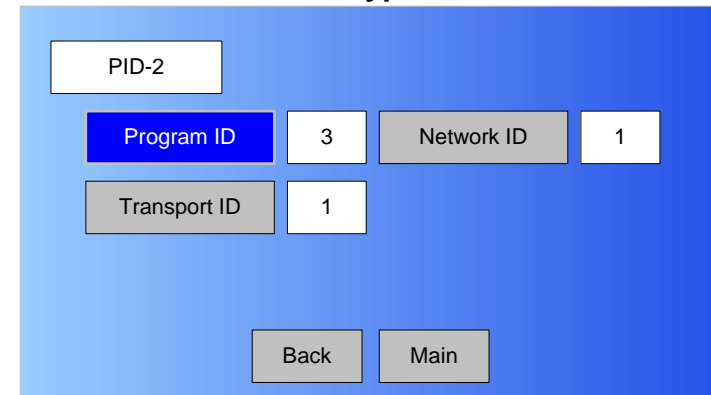
**Notes** To select the default PID settings, go to [step 50](#).

To enter individual PID settings, go to [step 51](#).

---

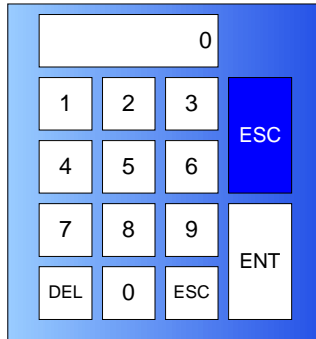
50. Select the **DEFAULT** option button and observe the default PID settings are displayed. Go to [step 71](#).
51. Select the **DATA** option button and observe the numeric keypad is displayed.
52. Enter the **DATA** PID required, select the **ENT** key, and observe the **PID** screen is displayed.
53. Select the **AUDIO A** option button and observe the numeric keypad is displayed.
54. Enter the **AUDIO A** PID required, select the **ENT** key, and observe the **PID** screen is displayed.
55. Select the **PMT** option button and observe the numeric keypad is displayed.

**Figure 5-96: PID-2 Screen - Typical**



64. Select the **Program ID** option button and observe the numeric keypad is displayed. See [Figure 5-97 on page 5-42](#).

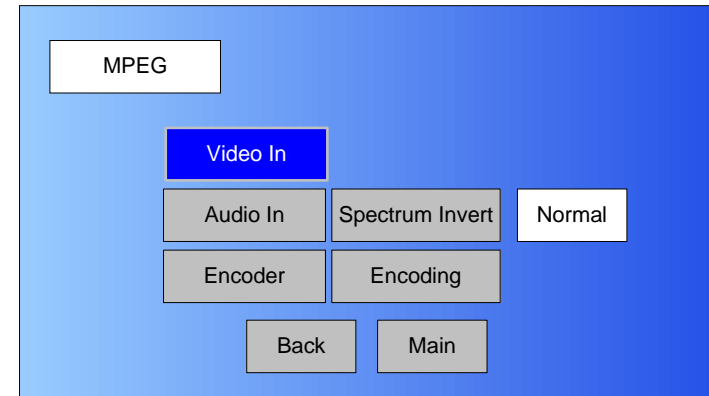
**Figure 5-97: Numeric Keypad**



65. Enter the **Program ID** PID required, select the **ENT** key, and observe the **PID-2** screen is displayed.
66. Select the **Network ID** option button and observe the numeric keypad is displayed.
67. Enter the **Network ID** PID required, select the **ENT** key, and observe the **PID-2** screen is displayed.
68. Select the **Transport ID** option button and observe the numeric keypad is displayed.
69. Enter the **Transport ID** PID required, select the **ENT** key, and observe the **PID-2** screen is displayed.
70. Select the **Back** option button and observe the **PID** screen is displayed.
71. Select the **Back** option button and observe the **Encoder** screen is displayed.
72. Select the **Remux** option button for **On** or **Off**, as required.
73. Select the **PTS per Picture** option button to select **On** or **Off**, as required.
74. Select the **Back** option button and observe the **Encoder** screen is displayed.

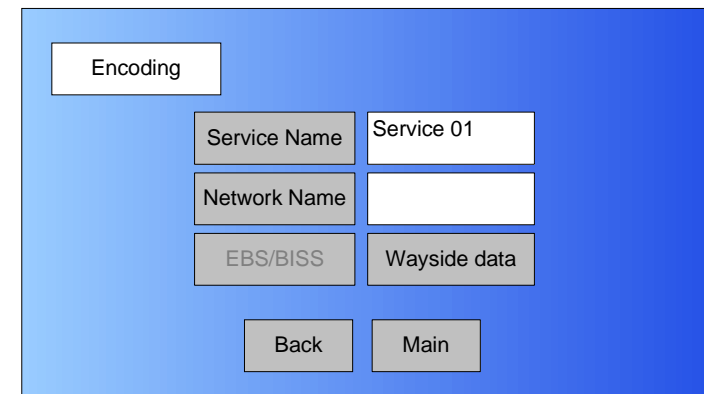
75. Select the **Back** option button and observe the **MPEG** screen is displayed. See [Figure 5-98](#).

**Figure 5-98: MPEG Screen - Typical**



76. Select the **Encoding** option button and observe the **Encoding** screen is displayed. See [Figure 5-99](#).

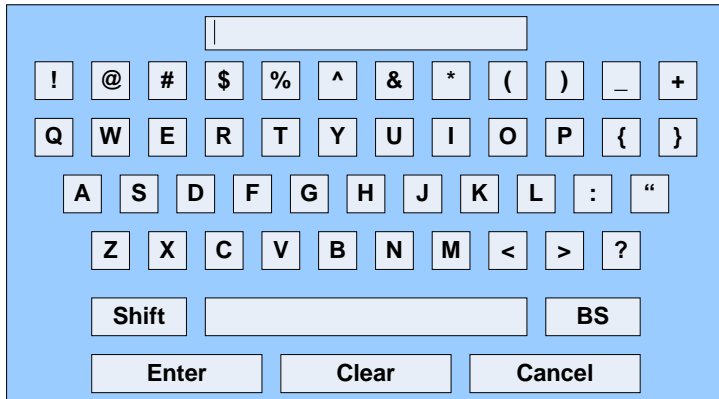
**Figure 5-99: Encoding Screen - Typical**



77. Select the **Service Name** option button and observe the keyboard screen is displayed. See [Figure 5-100](#).



**Figure 5-100: Keyboard Screen**



78. Enter the service name required, select the **Enter** key, and observe the **Encoding** screen is displayed.
79. Select the **Network Name** option button and observe the keyboard screen is displayed.
80. Enter the network name required, select the **Enter** key, and observe the **Encoding** screen is displayed.

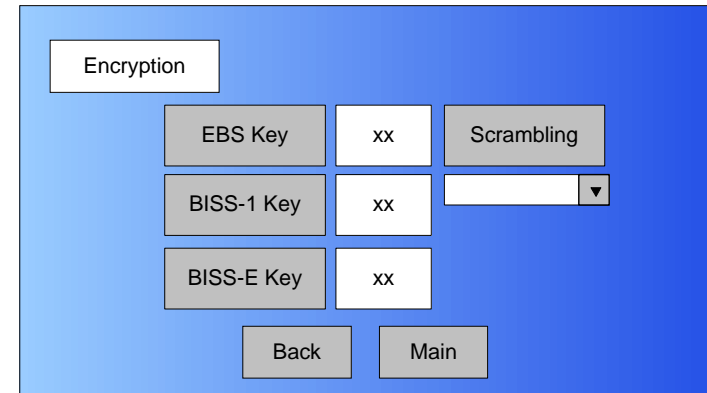
---

**Notes** If your MTX5000 IDU contains a licensed EBS or BISS encryption option, go to [step 81](#).

If your MTX5000 IDU does not contain a licensed EBS or BISS encryption option, go to [step 87](#).

- 
81. Observe the **EBS/BISS** option button is active (not greyed-out).
  82. Select the **EBS/BISS** option button and observe the **Encryption** screen is displayed. [See Figure 5-101](#).

**Figure 5-101: Encryption Screen**



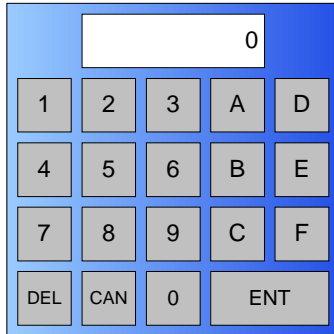

---

**Notes** You can only have one licensed encryption option contained in your MTX5000 IDU.

When the **Scrambling** pull-down menu **EBS**, **BISS-1**, or **BISS-E** option is selected in the following step, the selected option key will be active, but the two remaining option buttons will become inactive (greyed-out).

- 
83. Select the **Scrambling** pull-down menu **EBS**, **BISS-1**, or **BISS-E** option, as required, and observe the selected **EBS**, **BISS-1**, or **BISS-E** Key option button is active.
  84. Select the **EBS**, **BISS-1**, or **BISS-E** Key option button, as required, and observe the alphanumeric keypad is displayed. [See Figure 5-102 on page 5-44](#).

**Figure 5-102: Alphanumeric Keypad**



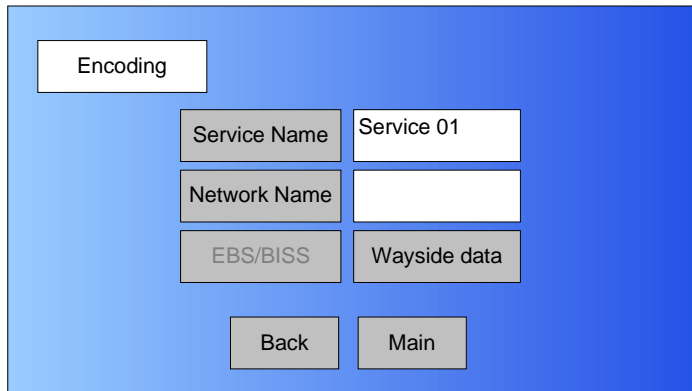
---

**Note** When the **Encryption** screen is displayed and the encryption key is entered in the following step, the encryption key will not be displayed.

---

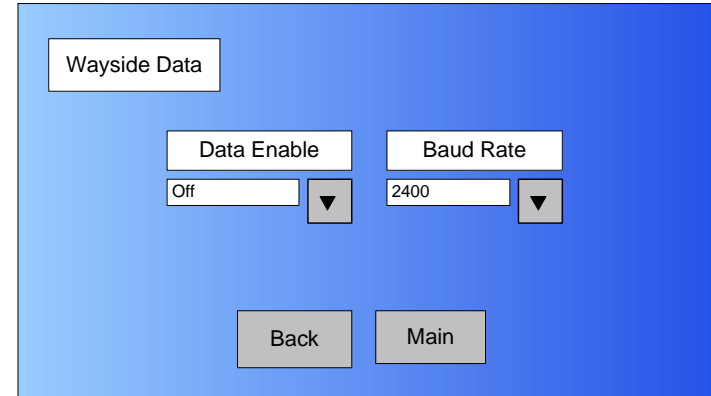
85. Enter your encryption key, select the **ENT** key, and observe the **Encryption** screen is displayed.
86. Select the **BACK** option button and observe the **Encoding** screen is displayed. [See Figure 5-103.](#)

**Figure 5-103: Encoding Screen - Typical**



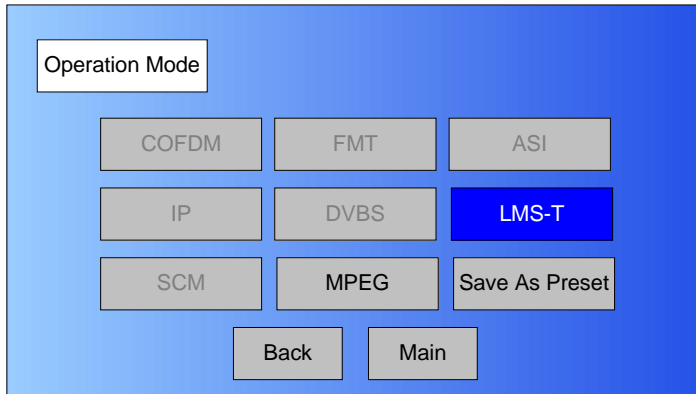
87. Select the **Wayside data** option button and observe the **Wayside Data** screen is displayed. [See Figure 5-104.](#)

**Figure 5-104: Wayside Data Screen - Typical**



88. Select the **Data Enable** pull-down menu and select the **Off**, **TTV Format**, **CJM2 Format**, or **Low Delay CJM2** option, as required.
89. Select the **Baud Rate** pull-down menu and select the **1200**, **2400**, **4800**, **9600**, **19200**, or **38400** option, as required.
90. Select the **Back** option button and observe the **Encoding** screen is displayed.
91. Select the **Back** option button and observe the **MPEG** screen is displayed.
92. Select the **Back** option button and observe the **Operation Mode** screen is displayed. [See Figure 5-105 on page 5-45.](#)

**Figure 5-105: Operation Mode Screen**



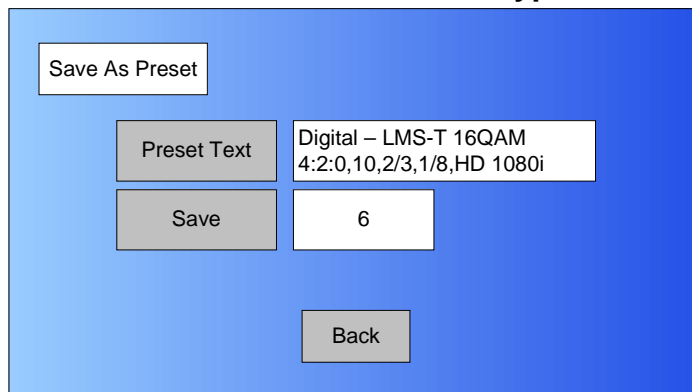
**Notes** In the following steps, if a factory default digital LMS-T Preset was used as a “make-from” to prepare this custom Preset, the **Preset Text** text box and the **Save** text box *must be* changed. **You cannot change or overwrite any factory default Presets!**

If a custom digital LMS-T Preset was used as a “make-from” to prepare this custom Preset, a brief description of the custom Preset must be entered in the **Preset Text** text box for easy identification purposes.

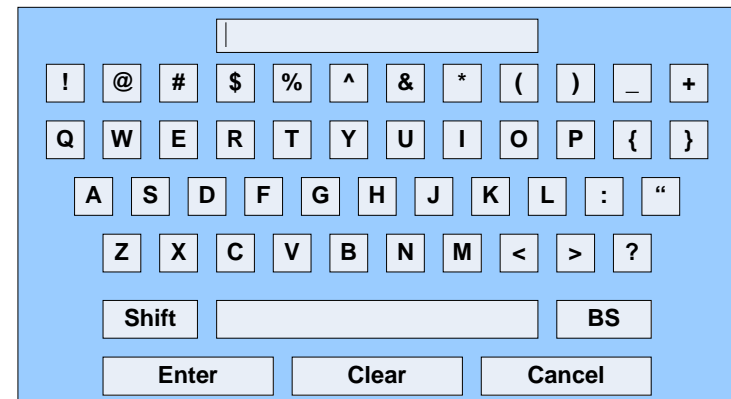
**Note** When the **Save As Preset** screen is displayed in the following step, the **Preset Text** and **Save** text boxes will display the name and identification of the digital LMS-T Preset currently being used as the digital LMS-T “make-from” for this custom Preset.

93. Select the **Save As Preset** option button and observe the **Save As Preset** screen is displayed. See [Figure 5-106](#).

**Figure 5-106: Save As Preset Screen - Typical**



**Figure 5-107: Keyboard Screen**



95. Enter a unique digital LMS-T Preset description, as required, and select the **Enter** key.
96. Observe the **Save As Preset** screen is displayed and the **Preset Text** text box displays the Preset description.

---

**Notes** When saving the new custom digital LMS-T Preset in the following step, the Preset number will automatically be increased to the next available Preset number to avoid overwriting an existing Preset.

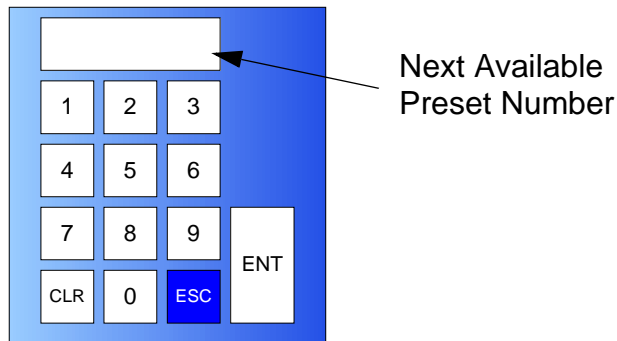
If you wish to overwrite the existing Preset number (unless it is a factory default Preset), enter the Preset number to be overwritten. A warning message will be displayed asking “**Are you sure?**”. Select the **Yes** option button.

Once an existing custom Preset is overwritten, it cannot be recovered. It must be re-entered from scratch.

---

97. Select the **Save** option button and observe the numeric keypad is displayed. See [Figure 5-108](#).

**Figure 5-108: Numeric Keypad**



---

**Notes** When saving Presets in the following steps, **Preset A** thru **Preset J** are factory default Presets. The factory default Preset numbers cannot be changed.

---

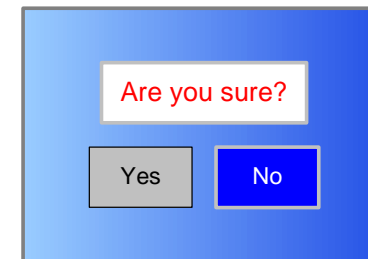
**Notes** To change the default Preset number, perform [step 98](#) and go to [step 99](#).

To accept the next available Preset number, go to [step 99](#).

---

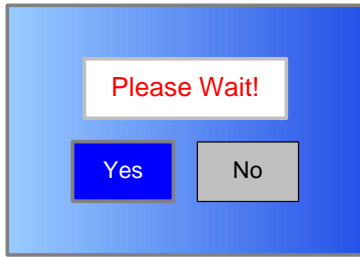
98. Select the **CLR** key and enter the Preset number required.
99. Select the **ENT** key and observe the **Are you sure?** confirmation screen is displayed. See [Figure 5-109](#).

**Figure 5-109: Confirmation Screen**



100. Select the **YES** option button and observe the **Please Wait!** message box is displayed. See [Figure 5-110 on page 5-47](#).

**Figure 5-110: Please Wait Message Box**



101. After a short delay, observe the **Save As Preset** screen is displayed.
102. Select the **Main** option button and observe the Main screen is displayed.

#### 5.4.5 Create or Update Digital DVB-S Preset Configuration Settings in Local Mode

The procedure required to create a new custom digital DVB-S Preset configuration or to update an existing digital DVB-S Preset configuration is contained in the following steps.

When preparing a new digital DVB-S Preset, you must first select an existing digital DVB-S Preset from either the digital DVB-S factory default Preset or from your own custom digital DVB-S Presets. The selected Preset will be used as a “make-from” to prepare the new digital DVB-S Preset configuration.

Please note that while factory default Presets may be used to prepare a new Preset configuration, these **factory default Presets cannot be changed or deleted**. They can only be used as “make-froms”.

When the new configuration is prepared using the factory default Preset, it cannot be saved with the factory Preset number or Preset name. A new Preset number and Preset name must be assigned to the new Preset.

When using a custom Preset as a “make-from”, the new Preset should be saved with a new Preset number. When you save the new Preset, the Preset number will automatically be increased to the next available Preset number. If you select an existing Preset number when saving the new Preset, the original custom Preset will be overwritten and cannot be recovered. The only way to restore a Preset that has been overwritten is to re-enter the custom Preset data from scratch.

If you are updating configuration settings on an existing custom Preset, when you save the configuration settings, the Preset number will automatically be increased to the next available Preset number. You must enter and save the configuration settings using the original Preset number.

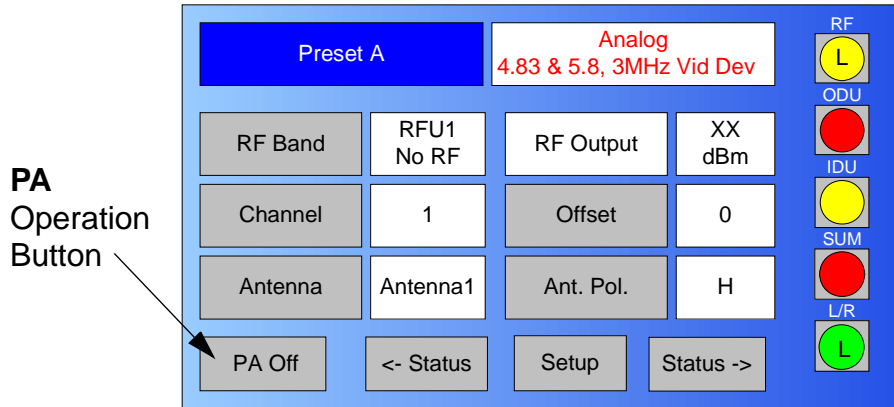
---

Note	In the following steps, the color LCD display option buttons and pull-down menu options may be selected using either the touch screen or the function keys and the <b>SEL</b> key.
------	--

---

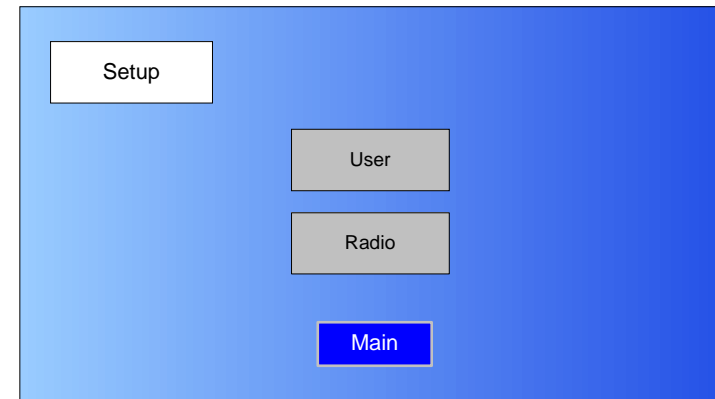
1. Verify the MTX5000 IDU is powered up. See ["Powering the MTX5000 System" on page 3-7](#).
2. Observe the Main screen is displayed. See [Figure 5-111 on page 5-48](#).

**Figure 5-111: Main Screen - Typical**



3. Select the **L/R** option button for **L** (local mode), as required.

**Figure 5-112: Setup Screen**



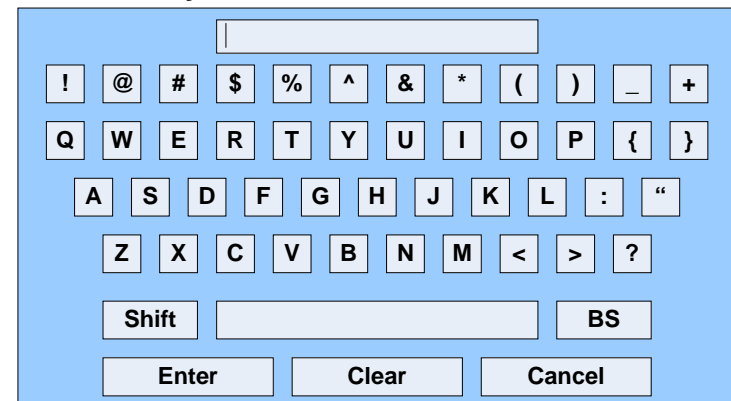
7. Select the **User** option button and observe the keyboard screen is displayed. See Figure 5-113.

**Notes** If you are updating an existing digital DVB-S Preset configuration, select the Preset to be updated in the following step.

If you are creating a new digital DVB-S Preset configuration, any digital DVB-S Preset may be selected in the following step.

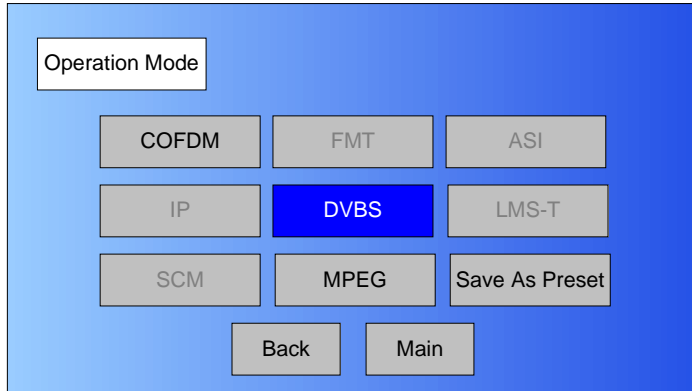
4. Perform “[Select Preset](#)” on page 3-24 to select the digital DVB-S Preset required to be updated or to be used as a “make-from”.
5. Select the Main screen **PA** operation button for **PA Off**, as required.
6. Select the Main screen **Setup** option button and observe the **Setup** screen is displayed. See Figure 5-112.

**Figure 5-113: Keyboard Screen**



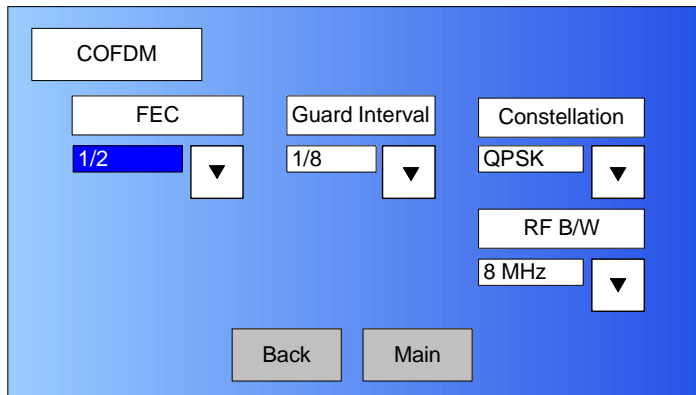
8. Enter your password, select the **Enter** key, and observe the **Operation Mode** screen is displayed. See Figure 5-114 on page 5-49.

**Figure 5-114: Operation Mode Screen**



9. Select the **COFDM** option button and observe the **COFDM** screen is displayed. See Figure 5-115.

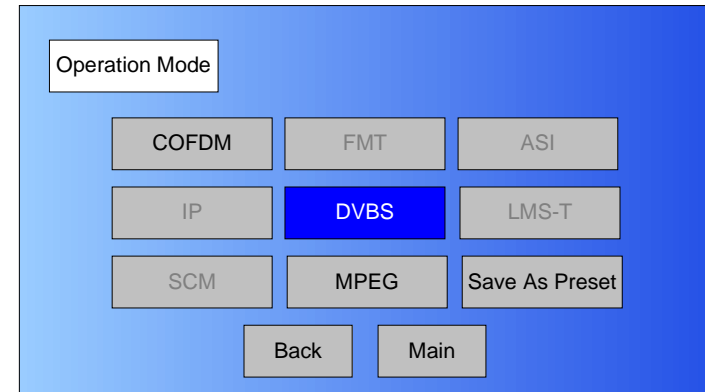
**Figure 5-115: COFDM Screen - Typical**



10. Use the **FEC** (Forward Error Correction) pull-down menu and select **1/2**, **2/3**, **3/4**, **5/6**, or **7/8**, as required.
11. Use the **Guard Interval** pull-down menu and select **1/32**, **1/16**, **1/8**, or **1/4**, as required.
12. Use the **Constellation** pull-down menu to select **QPSK**, **16-QAM** or **8-PSK**, as required.

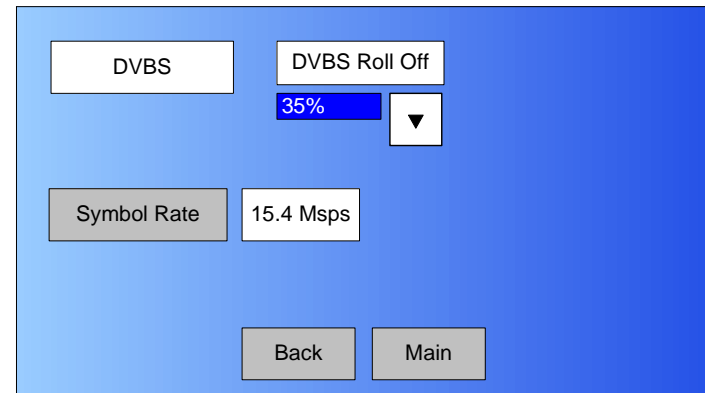
13. Use the **RF B/W** pull-down menu to select **6 MHz**, **7 MHz**, or **8 MHz**, as required.
14. Select the **Back** option button and observe the **Operation Mode** screen is displayed. See Figure 5-116.

**Figure 5-116: Operation Mode Screen**



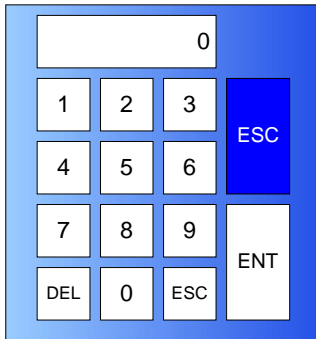
15. Select the **DVBS** option button and observe the **DVBS** screen is displayed. See Figure 5-117.

**Figure 5-117: DVBS Screen - Typical**



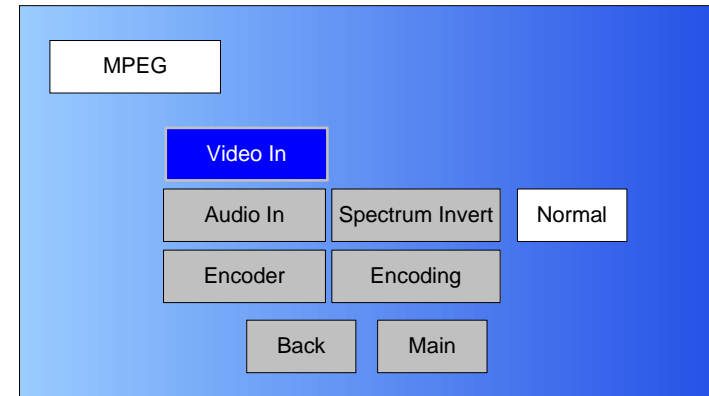
16. Use the **DVBS Roll Off** pull-down menu to select **20%**, **25%**, or **35%**, as required.
17. Select the **Symbol Rate** option button and observe the numeric keypad is displayed. See Figure 5-118.

**Figure 5-118: Numeric Keypad**



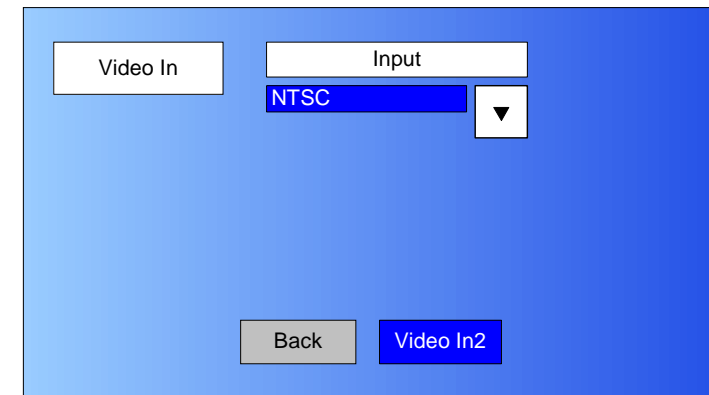
18. Enter the symbol rate required, select the **ENT** key, and observe the **DVBS** screen is displayed.
19. Select the **Back** option button and observe the **Operation Mode** screen is displayed.
20. Select the **MPEG** option button and observe the **MPEG** screen is displayed. See Figure 5-119.

**Figure 5-119: MPEG Screen - Typical**



21. Select the **Video In** option button and observe the **Video In** screen is displayed. See Figure 5-120.

**Figure 5-120: Video In Screen 1 - Typical**




---

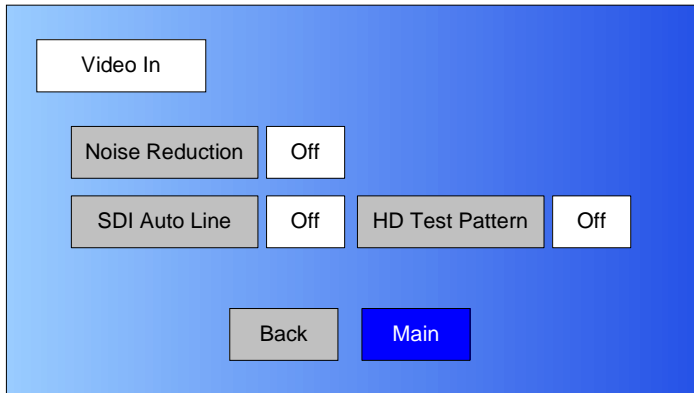
**Note** In the following step, select an **Input** option applicable to the licensed options contained in your MTX5000 IDU only. Selection of an option that is not licensed in your radio will cause the IDU to operate in the NTSC default mode.

---



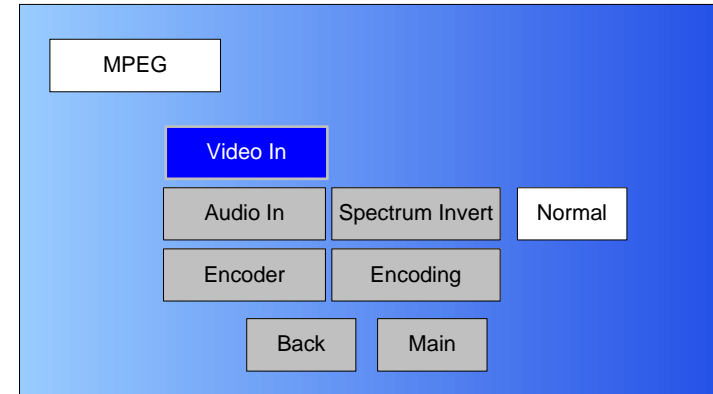
22. Use the **Input** pull-down menu to select the video input option required.
23. Select the **Video In2** option button and observe the **Video In** screen 2 is displayed. See Figure 5-121.

**Figure 5-121: Video In Screen 2 - Typical**



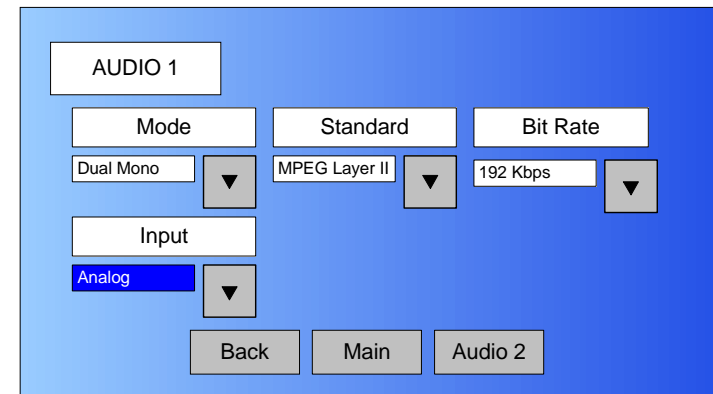
24. Select the **Noise Reduction** option button for **On** or **Off**, as required.
25. Select the **SDI Auto Line** option button for **On** or **Off**, as required.
26. Select the **HD Test Pattern** option button for **On** or **Off**, as required.
27. Select the **Back** option button and observe the **Video In** screen is displayed.
28. Select the **Back** option button and observe the **MPEG** screen is displayed. See Figure 5-122.

**Figure 5-122: MPEG Screen - Typical**



29. Select the **Audio In** option button and observe the **AUDIO 1** screen is displayed. See Figure 5-123.

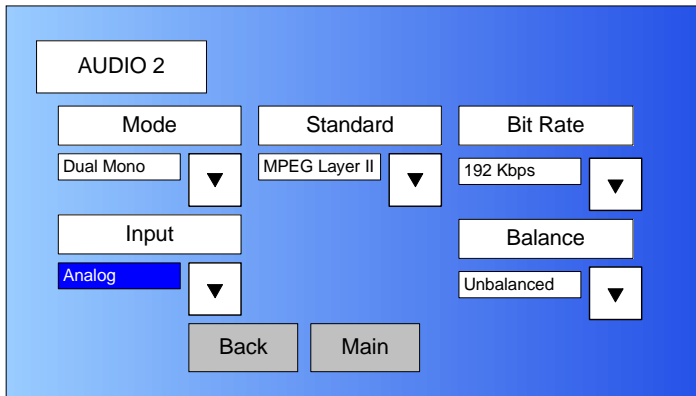
**Figure 5-123: AUDIO 1 Screen - Typical**



30. Use the **Mode** pull-down menu to select **Stereo** or **Dual Mono**, as required.
31. Use the **Standard** pull-down menu to select **Off**, **MPEG Layer II**, **Linear PCM**, or **MPEG Layer I**, as required.

32. Use the **Bit Rate** pull-down menu to select **128 Kbps**, **160 Kbps**, **192 Kbps**, **224 Kbps**, **256 Kbps**, **320 Kbps**, or **384 Kbps**, as required.
33. Use the **Input** pull-down menu to select **Test Tone**, **Analog**, or **SDI Emb**, as required.
34. Select the **Audio 2** option button and observe the **AUDIO 2** screen is displayed. See Figure 5-124.

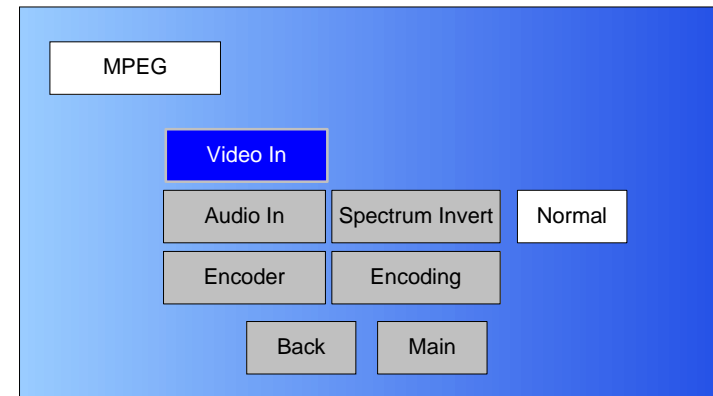
**Figure 5-124: AUDIO 2 Screen - Typical**



35. Use the **Mode** pull-down menu to select **Stereo** or **Dual Mono**, as required.
36. Use the **Standard** pull-down menu to select **Off**, **MPEG Layer II**, **Linear PCM**, or **MPEG Layer I**, as required.
37. Use the **Bit Rate** pull-down menu to select **128 Kbps**, **160 Kbps**, **192 Kbps**, **224 Kbps**, **256 Kbps**, **320 Kbps**, or **384 Kbps**, as required.
38. Use the **Input** pull-down menu to select **Test Tone**, **Analog**, **SDI Emb**, **AES-EBU**, or **Channel Ide**, as required.
39. Use the **Balance** pull-down menu to select **Unbalanced** or **Balanced**, as required.

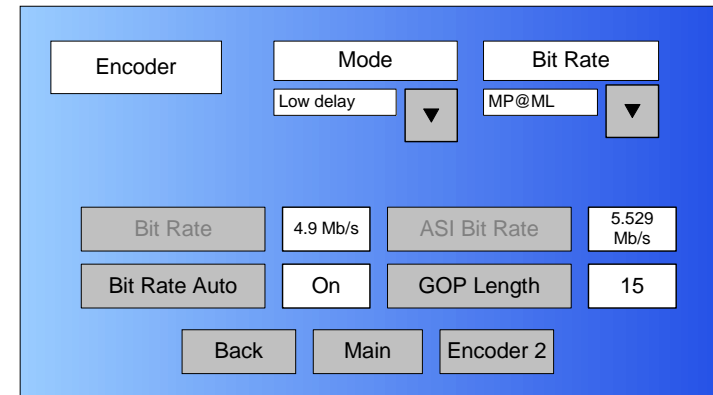
40. Select the **Back** option button and observe the **AUDIO 1** screen is displayed.
41. Select the **Back** option button and observe the **MPEG** screen is displayed. See Figure 5-125.

**Figure 5-125: MPEG Screen - Typical**



42. Select the **Spectrum Invert** option button to select **Normal** or **Inverted**, as required.
43. Select the **Encoder** option button and observe the **Encoder** screen is displayed. See Figure 5-126.

**Figure 5-126: Encoder Screen - Typical**



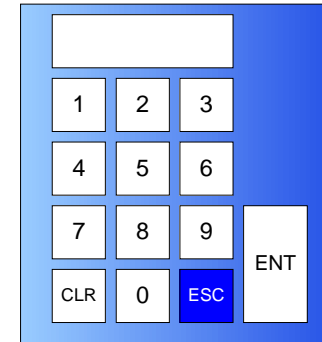
44. Select the **Mode** pull-down menu and select **Standard** or **Low delay**, as required.
45. Select the **Bit Rate** pull-down menu and select **MP@ML** or **422P@ML**, as required.

49. Select the **GOP Length** option button and observe the numeric keypad is displayed. See [Figure 5-128](#).

**Notes** In the following step, if the **Bit Rate Auto** option button selected is **On**, the **Bit Rate** option button will be inactive (greyed out). Go to [step 47](#).

If the **Bit Rate Auto** option button selected is **Off**, the **Bit Rate** option button will be active. Go to [step 46](#).

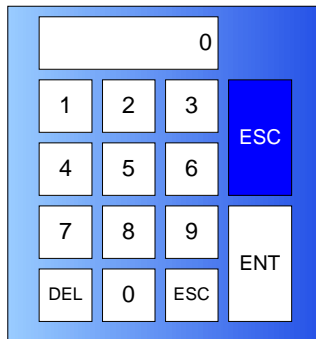
**Figure 5-128: Numeric Keypad**



46. Select the **Bit Rate Auto** option button for **Off** or **On**, as required.
47. Observe the **Bit Rate** option button is active. Select the **Bit Rate** option button and observe the numeric keypad is displayed. See [Figure 5-127](#).

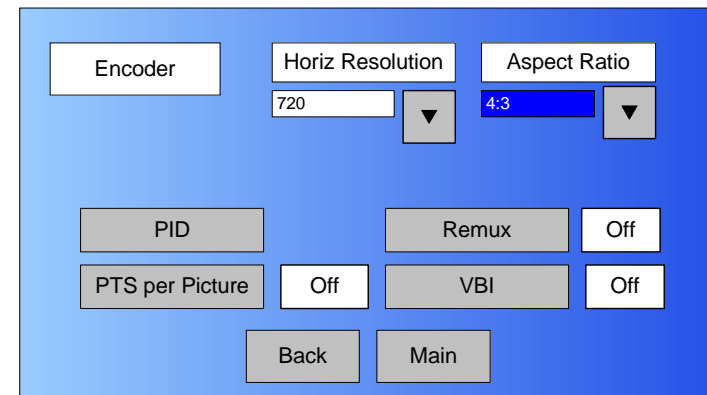
50. Enter the Group of Pictures (GOP) number required, select the **ENT** key, and observe the **Encoder** screen is displayed.
51. Select the **Encoder 2** option button and observe the **Encoder** screen is displayed. See [Figure 5-129](#).

**Figure 5-127: Numeric Keypad**



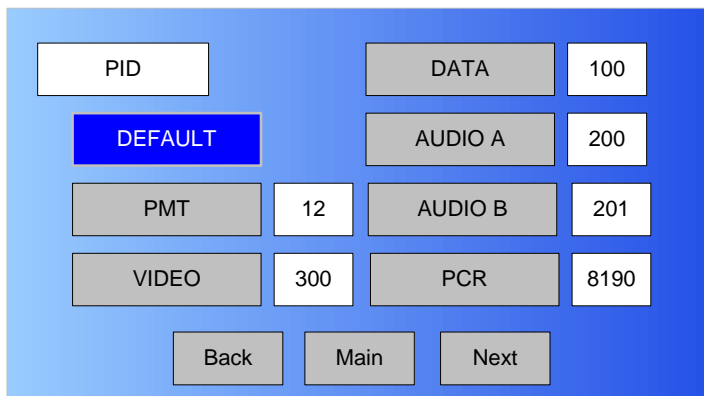
48. Enter the bit rate required, select the **ENT** key, and observe the **Encoder** screen is displayed.

**Figure 5-129: Encoder Screen 2 - Typical**



52. Select the **Horiz Resolution** pull-down menu and select **720, 704, 544, 528, 480, or 352**, as required.
53. Select the **Aspect Ratio** pull-down menu and select **4:3 or 16:9**, as required.
54. Select the **PID** option button and observe the **PID** screen is displayed. See [Figure 5-130](#).

**Figure 5-130: PID Screen - Typical**



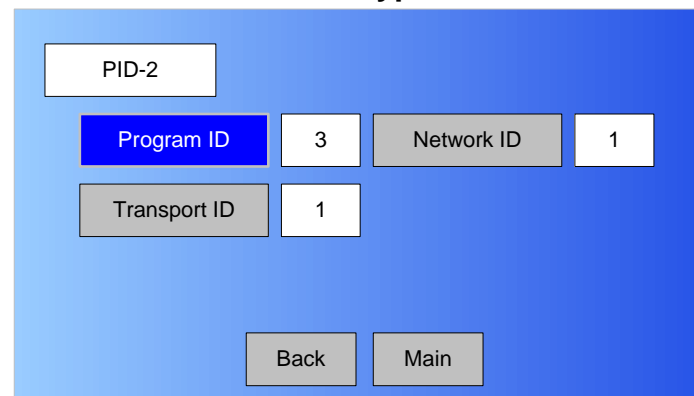
59. Enter the **AUDIO A** PID required, select the **ENT** key, and observe the **PID** screen is displayed.
60. Select the **PMT** option button and observe the numeric keypad is displayed.
61. Enter the **PMT** PID required, select the **ENT** key, and observe the **PID** screen is displayed.
62. Select the **AUDIO B** option button and observe the numeric keypad is displayed.
63. Enter the **AUDIO B** PID required, select the **ENT** key, and observe the **PID** screen is displayed.
64. Select the **VIDEO** option button and observe the numeric keypad is displayed.
65. Enter the **Video** PID required, select the **ENT** key, and observe the **PID** screen is displayed.
66. Select the **PCR** option button and observe the numeric keypad is displayed.
67. Enter the **PCR** PID required, select the **ENT** key, and observe the **PID** screen is displayed.
68. Select the **Next** option button and observe the **PID-2** screen is displayed. See [Figure 5-131](#).

**Notes** To select the default PID settings, go to [step 55](#).

To enter individual PID settings, go to [step 56](#).

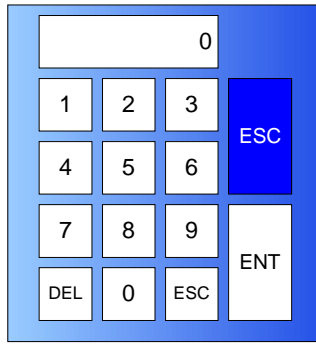
55. Select the **DEFAULT** option button and observe the default PID settings are displayed. Go to [step 75](#).
56. Select the **DATA** option button and observe the numeric keypad is displayed.
57. Enter the **DATA** PID required, select the **ENT** key, and observe the **PID** screen is displayed.
58. Select the **AUDIO A** option button and observe the numeric keypad is displayed.

**Figure 5-131: PID-2 Screen - Typical**



69. Select the **Program ID** option button and observe the numeric keypad is displayed. See [Figure 5-132](#).

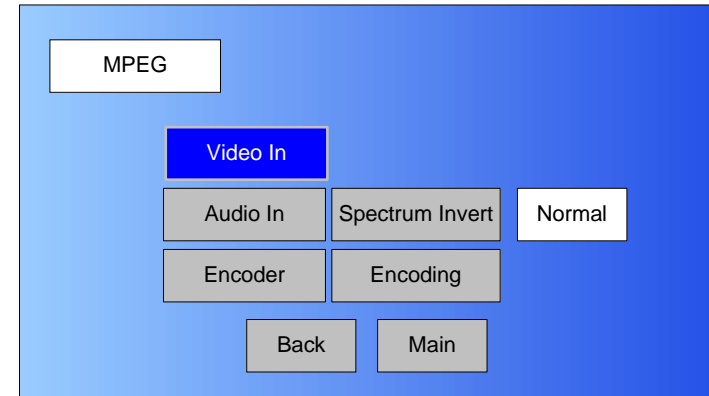
**Figure 5-132: Numeric Keypad**



70. Enter the **Program ID** PID required, select the **ENT** key, and observe the **PID-2** screen is displayed.
71. Select the **Network ID** option button and observe the numeric keypad is displayed.
72. Enter the **Network ID** PID required, select the **ENT** key, and observe the **PID-2** screen is displayed.
73. Select the **Transport ID** option button and observe the numeric keypad is displayed.
74. Enter the **Transport ID** PID required, select the **ENT** key, and observe the **PID-2** screen is displayed.
75. Select the **Back** option button and observe the **PID** screen is displayed.
76. Select the **Back** option button and observe the **Encoder** screen is displayed.
77. Select the **Remux** option button for **On** or **Off**, as required.
78. Select the **PTS per Picture** option button to select **On** or **Off**, as required.

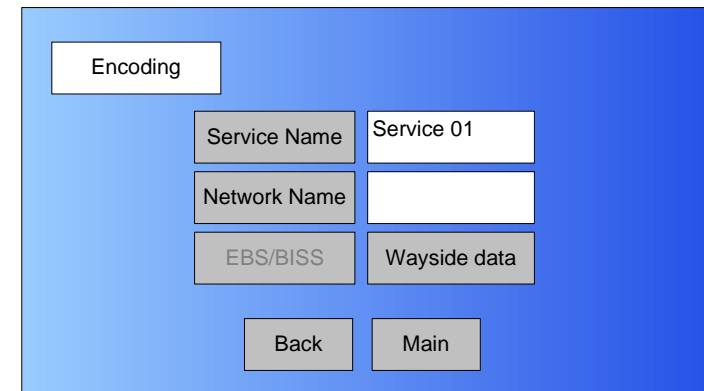
79. Select the **Back** option button and observe the **Encoder** screen is displayed.
80. Select the **Back** option button and observe the **MPEG** screen is displayed. See [Figure 5-133](#).

**Figure 5-133: MPEG Screen - Typical**



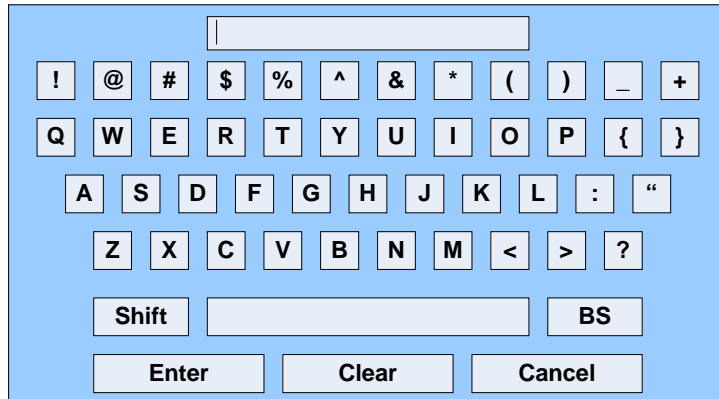
81. Select the **Encoding** option button and observe the **Encoding** screen is displayed. See [Figure 5-134](#).

**Figure 5-134: Encoding Screen - Typical**



82. Select the **Service Name** option button and observe the keyboard screen is displayed. See [Figure 5-135](#).

**Figure 5-135: Keyboard Screen**



83. Enter the service name required, select the **Enter** key, and observe the **Encoding** screen is displayed.
84. Select the **Network Name** option button and observe the keyboard screen is displayed.
85. Enter the network name required, select the **Enter** key, and observe the **Encoding** screen is displayed.

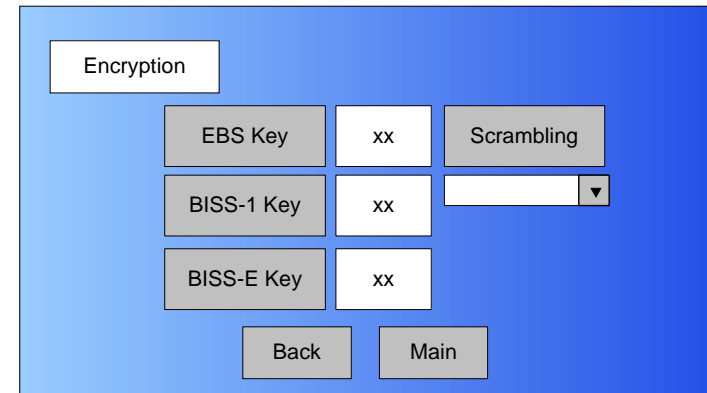
---

**Notes** If your MTX5000 IDU contains a licensed EBS or BISS encryption option, go to [step 86](#).

If your MTX5000 IDU does not contain a licensed EBS or BISS encryption option, go to [step 91](#).

86. Observe the **EBS/BISS** option button is active (not greyed-out).
87. Select the **EBS/BISS** option button and observe the **Encryption** screen is displayed. See [Figure 5-136](#).

**Figure 5-136: Encryption Screen**



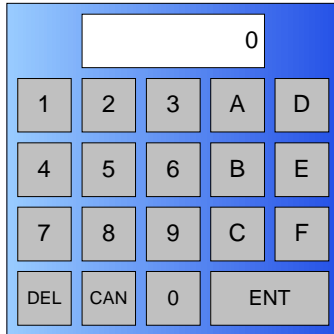

---

**Notes** You can only have one licensed encryption option contained in your MTX5000 IDU.

When the **Scrambling** pull-down menu **EBS**, **BISS-1**, or **BISS-E** option is selected in the following step, the selected option key will be active, but the two remaining option buttons will become inactive (greyed-out).

88. Select the **Scrambling** pull-down menu **EBS**, **BISS-1**, or **BISS-E** option, as required, and observe the selected **EBS**, **BISS-1**, or **BISS-E Key** option button is active.
89. Select the **EBS**, **BISS-1**, or **BISS-E Key** option button, as required, and observe the alphanumeric keypad is displayed. See [Figure 5-137 on page 5-57](#).

**Figure 5-137: Alphanumeric Keypad**



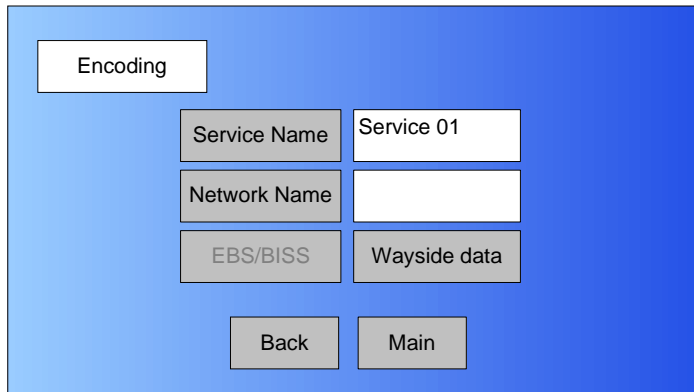
---

**Note** When the **Encryption** screen is displayed and the encryption key is entered in the following step, the encryption key will not be displayed.

---

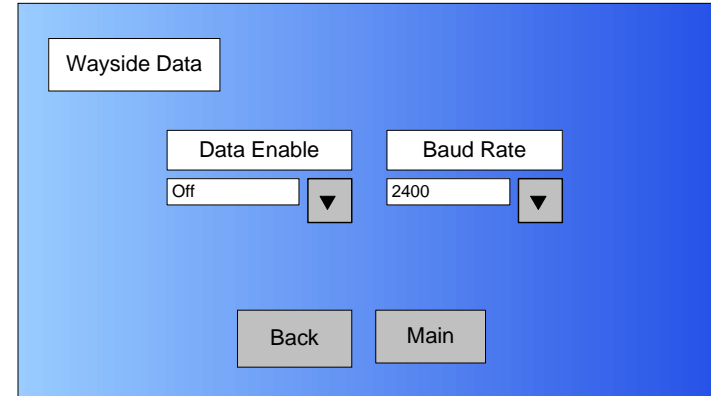
90. Enter your encryption key, select the **ENT** key, and observe the **Encryption** screen is displayed.
91. Select the **Back** option button and observe the **Encoding** screen is displayed. [See Figure 5-138.](#)

**Figure 5-138: Encoding Screen - Typical**



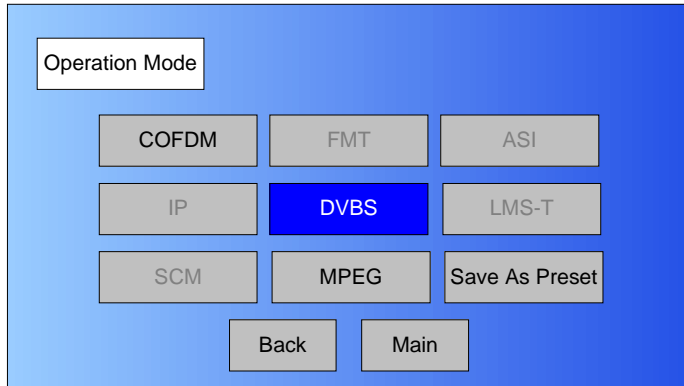
92. Select the **Wayside data** option button and observe the **Wayside Data** screen is displayed. [See Figure 5-139.](#)

**Figure 5-139: Wayside Data Screen - Typical**



93. Select the **Data Enable** pull-down menu and select the **Off**, **TTV Format**, **CJM2 Format**, or **Low Delay CJM2** option, as required.
94. Select the **Baud Rate** pull-down menu and select the **1200**, **2400**, **4800**, **9600**, **19200**, or **38400** option, as required.
95. Select the **Submit** option button.
96. Select the **Back** option button and observe the **Encoding** screen is displayed.
97. Select the **Back** option button and observe the **MPEG** screen is displayed.
98. Select the **Back** option button and observe the **Operation Mode** screen is displayed. [See Figure 5-140 on page 5-58.](#)

**Figure 5-140: Operation Mode Screen**



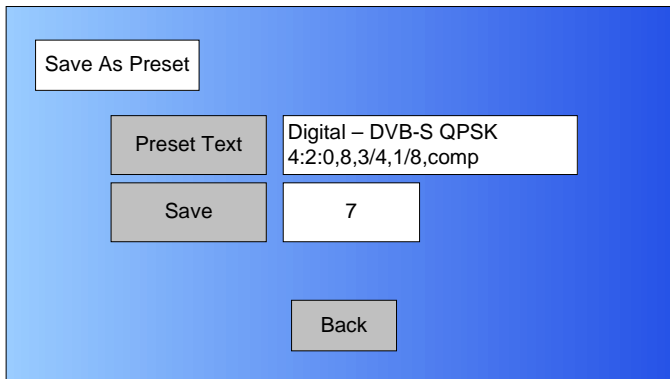
**Notes** In the following steps, if a factory default digital IP Preset was used as a “make-from” to prepare this custom Preset, the **Preset Text** text box and the **Save** text box *must be* changed. **You cannot change or overwrite any factory default Presets!**

If a custom digital IP Preset was used as a “make-from” to prepare this custom Preset, a brief description of the custom Preset must be entered in the **Preset Text** text box for easy identification purposes.

**Note** When the **Save As Preset** screen is displayed in the following step, the **Preset Text** and **Save** text boxes will display the name and identification of the digital IP Preset currently being used as the digital IP “make-from” for this custom Preset.

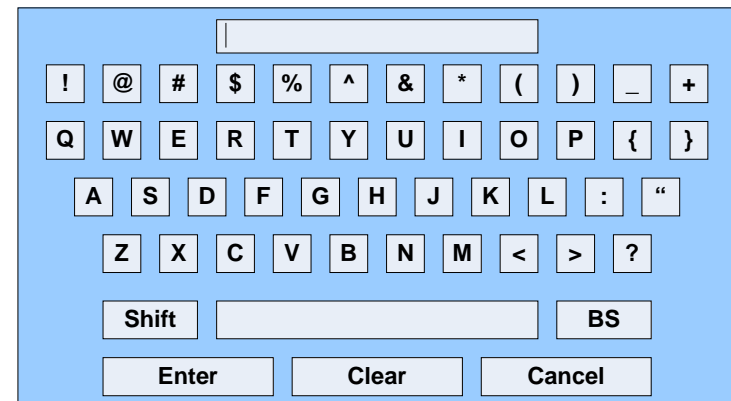
99. Select the **Save As Preset** option button and observe the **Save As Preset** screen is displayed. See [Figure 5-141](#).

**Figure 5-141: Save As Preset Screen - Typical**



100. Select the **Preset Text** option button and observe the keyboard screen is displayed. See [Figure 5-142](#).

**Figure 5-142: Keyboard Screen**



101. Enter a unique digital IP Preset description, as required, and select the **Enter** key.
102. Observe the **Save As Preset** screen is displayed and the **Preset Text** text box displays the Preset description.



---

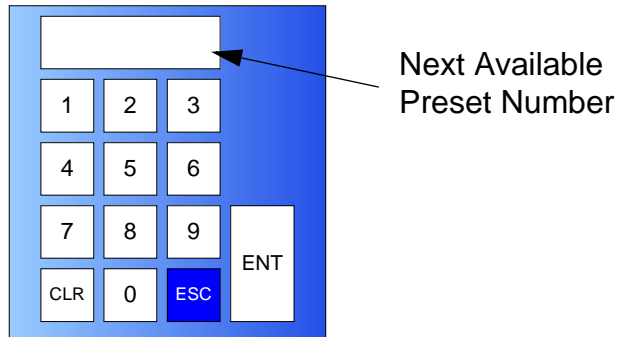
**Notes** When saving the new custom digital IP Preset in the following step, the Preset number will automatically be increased to the next available Preset number to avoid overwriting an existing Preset.

If you wish to overwrite the existing Preset number (unless it is a factory default Preset), enter the Preset number to be overwritten. A warning message will be displayed asking “**Are you sure?**”. Select the **Yes** option button.

Once an existing custom Preset is overwritten, it cannot be recovered. It must be re-entered from scratch.

- 
103. Select the **Save** option button and observe the numeric keypad is displayed. See [Figure 5-143](#).

**Figure 5-143: Numeric Keypad**



---

**Notes** When saving Presets in the following steps, **Preset A** thru **Preset J** are factory default Presets. The factory default Preset numbers cannot be changed.

---

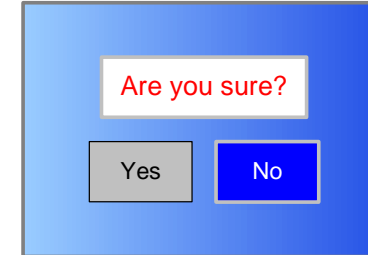
---

**Notes** To change the default Preset number, perform [step 104](#) and go to [step 105](#).

To accept the next available Preset number, go to [step 105](#).

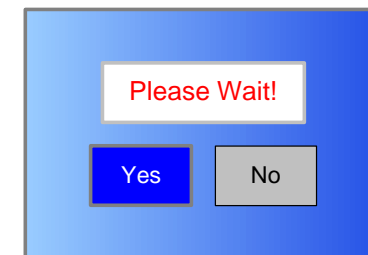
- 
104. Select the **CLR** key and enter the Preset number required.
105. Select the **ENT** key and observe the **Are you sure?** confirmation screen is displayed. See [Figure 5-144](#).

**Figure 5-144: Confirmation Screen**



106. Select the **YES** option button and observe the **Please Wait!** message box is displayed. See [Figure 5-145](#).

**Figure 5-145: Please Wait Message Box**



107. After a short delay, observe the **Save As Preset** screen is displayed.

108. Select the **Main** option button and observe the Main screen is displayed.

### 5.4.6 Create or Update Digital IP Preset Configuration Settings in Local Mode

The procedure required to create a new custom digital IP Preset configuration or to update an existing digital IP Preset configuration is contained in the following steps.

When preparing a new digital IP Preset, you must first select an existing digital IP Preset from either the digital IP factory default Preset or from your own custom digital IP Presets. The selected Preset will be used as a “make-from” to prepare the new digital IP Preset configuration.

Please note that while factory default Presets may be used to prepare a new Preset configuration, these **factory default Presets cannot be changed or deleted**. They can only be used as “make-froms”.

When the new configuration is prepared using the factory default Preset, it cannot be saved with the factory Preset number or Preset name. A new Preset number and Preset name must be assigned to the new Preset.

When using a custom Preset as a “make-from”, the new Preset should be saved with a new Preset number. When you save the new Preset, the Preset number will automatically be increased to the next available Preset number. If you select an existing Preset number when saving the new Preset, the original custom Preset will be overwritten and cannot be recovered. The only way to restore a Preset that has been overwritten is to re-enter the custom Preset data from scratch.

If you are updating configuration settings on an existing custom Preset, when you save the configuration settings, the Preset

number will automatically be increased to the next available Preset number. You must enter and save the configuration settings using the original Preset number.

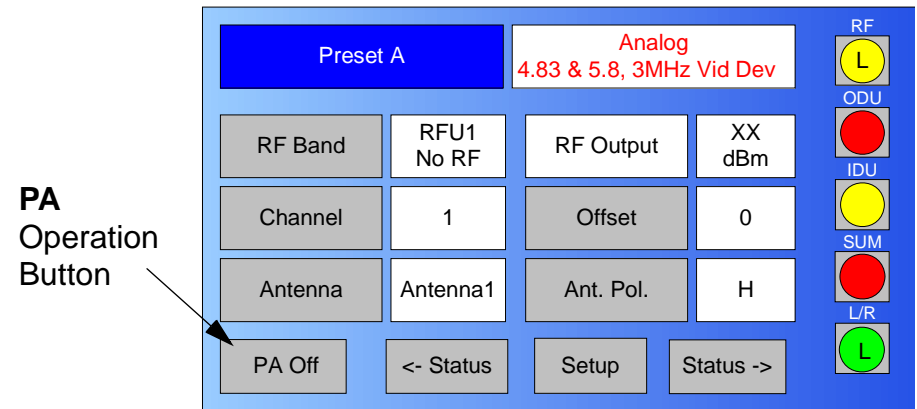
---

**Note** In the following steps, the color LCD display option buttons and pull-down menu options may be selected using either the touch screen or the function keys and the **SEL** key.

---

1. Verify the MTX5000 IDU is powered up. See ["Powering the MTX5000 System" on page 3-7](#).
2. Observe the Main screen is displayed. See [Figure 5-146](#).

**Figure 5-146: Main Screen - Typical**



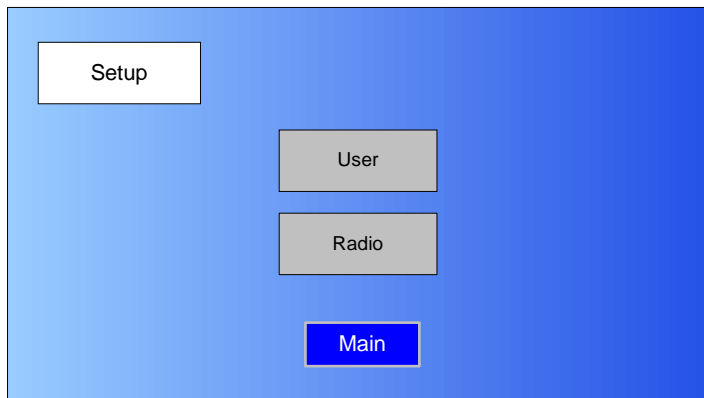
3. Select the **L/R** option button for **L** (local mode), as required.

**Notes** If you are updating an existing digital IP Preset configuration, select the Preset to be updated in the following step.

If you are creating a new digital IP Preset configuration, any digital IP Preset may be selected in the following step.

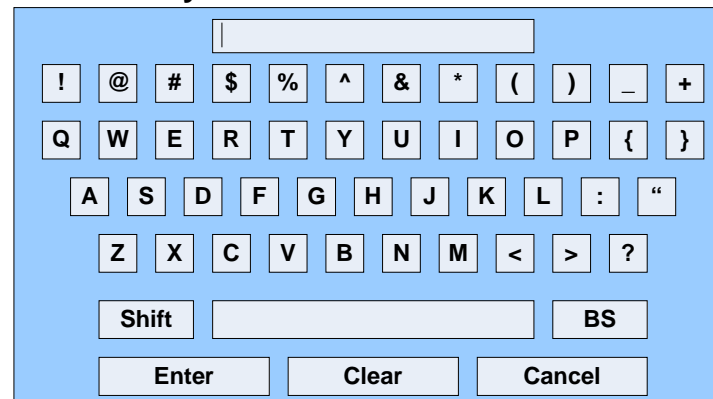
4. Perform “[Select Preset](#)” on [page 3-24](#) to select the digital IP Preset required to be updated or to be used as a “make-from”.
5. Select the Main screen **PA** operation button for **PA Off**, as required.
6. Select the Main screen **Setup** option button and observe the **Setup** screen is displayed. [See Figure 5-147](#).

**Figure 5-147: Setup Screen**



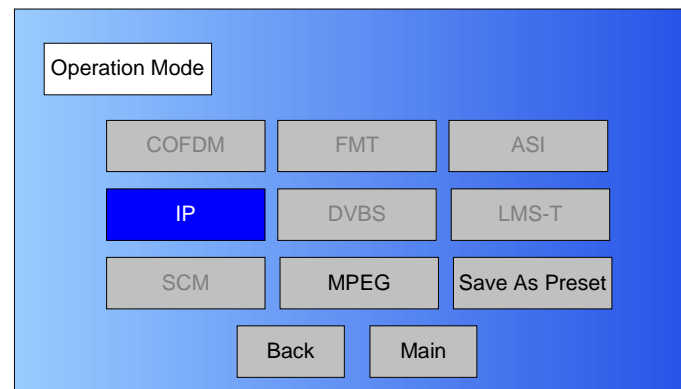
7. Select the **User** option button and observe the keyboard screen is displayed. [See Figure 5-148](#).

**Figure 5-148: Keyboard Screen**



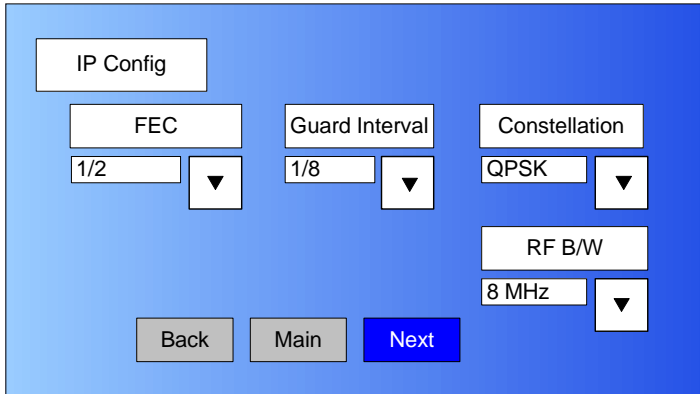
8. Enter your password, select the **Enter** key, and observe the **Operation Mode** screen is displayed. [See Figure 5-149](#).

**Figure 5-149: Operation Mode Screen**



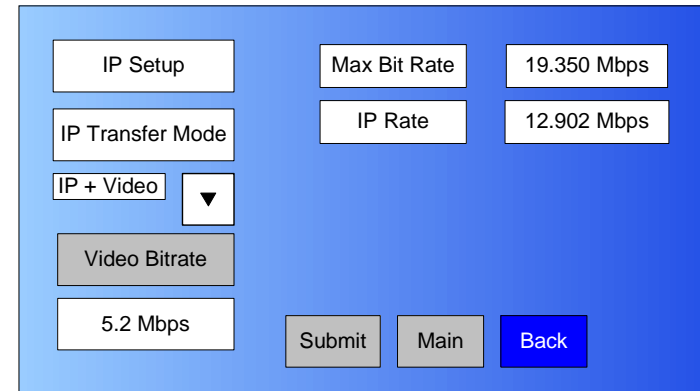
9. Select the **IP** option button and observe the **IP Config** screen is displayed. [See Figure 5-150 on page 5-62](#).

Figure 5-150: IP Config Screen - Typical



10. Use the **FEC** pull-down menu to select **1/2**, **2/3**, **3/4**, **5/6**, or **7/8**, as required
11. Use the **Guard Interval** pull-down menu and select **1/32**, **1/16**, **1/4**, or **1/8**, as required.
12. Use the **Constellation** pull-down menu to select **QPSK**, **16-QAM**, or **64-QAM**, as required.
13. Use the **RF B/W** pull-down menu to select **6 MHZ**, **7 MHZ**, or **8 MHZ**, as required.
14. Select the **Next** option button and observe the **IP Setup** screen is displayed. See [Figure 5-151](#).

Figure 5-151: IP Setup Screen - Typical



---

**Notes** If the **IP + Video** option is selected in the following step, go to [step 16](#).

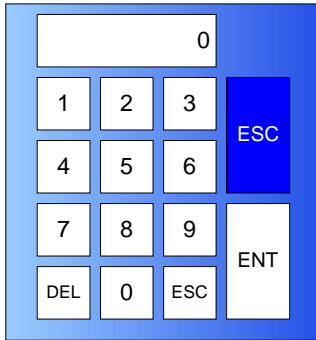
The **Video Bitrate** option button is active only if the **IP + Video** option is selected.

If the **IP Only** option is selected in the following step, go to [step 20](#).

---

15. Use the **IP Transfer Mode** pull-down menu to select **IP Only** or **IP + Video**, as required, and select the **Submit** option button.
16. Observe the **Video Bitrate** option button is active.
17. Select the **Video Bitrate** option button and observe the numeric keypad is displayed. See [Figure 5-152 on page 5-63](#).

Figure 5-152: Numeric Keypad



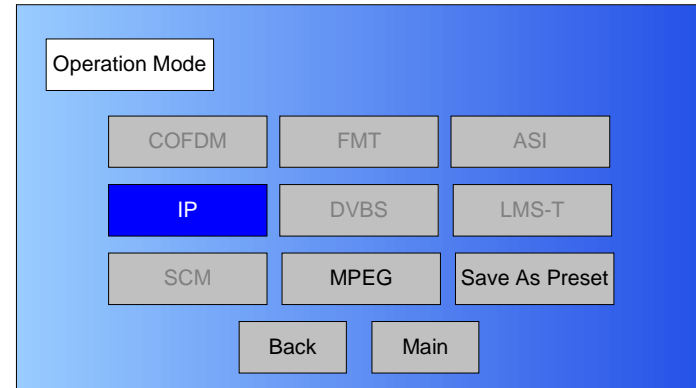
**CAUTION**

When entering the video bit rate in the following step, the bit rate value entered cannot exceed the **IP Setup** screen **Max Bit Rate** value minus 1.22 Mbps. Exceeding the **Max Bit Rate** value minus 1.22 Mbps will result in no video output.

For example, a **Max Bit Rate** value of 19.350 Mbps - 1.22 Mbps = 18.130 Mbps. Therefore, the video bit rate entered in the following step must not exceed 18.130 Mbps.

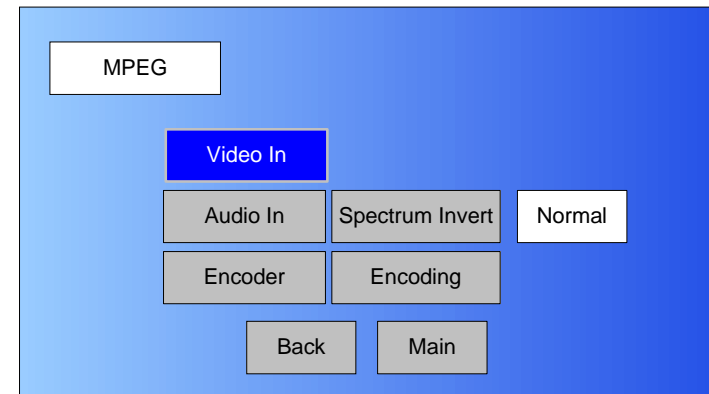
18. Enter the video bit rate required and select the **ENT** option button.
19. Select the **Submit** option button.
20. Select the **Back** option button and observe the **IP Config** screen is displayed.
21. Select the **Back** option button and observe the **Operation Mode** screen is displayed. See Figure 5-153.

Figure 5-153: Operation Mode Screen



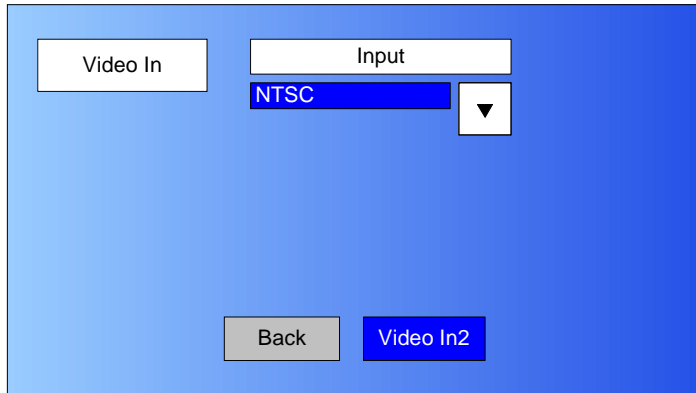
22. Select the **MPEG** option button and observe the **MPEG** screen is displayed. See Figure 5-154.

Figure 5-154: MPEG Screen - Typical

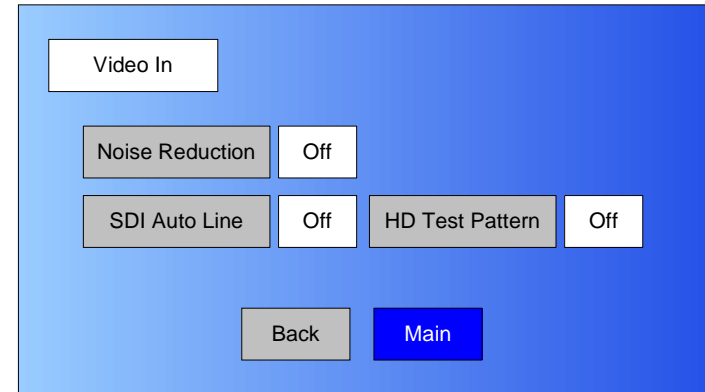


23. Select the **Video In** option button and observe the **Video In** screen is displayed. See Figure 5-155 on page 5-64.

**Figure 5-155: Video In Screen 1 - Typical**



**Figure 5-156: Video In Screen 2 - Typical**



---

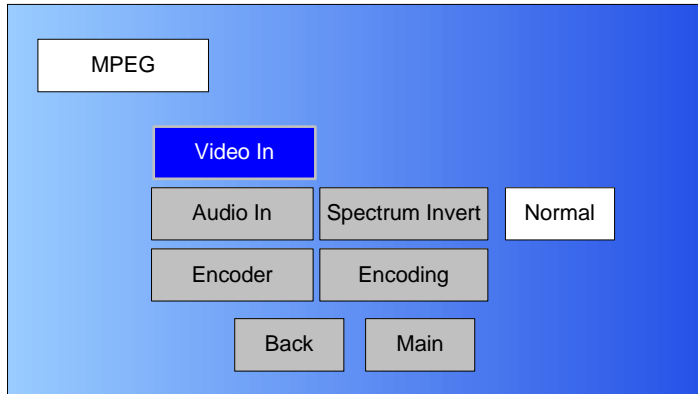
**Note** In the following step, select an **Input** option applicable to the licensed options contained in your MTX5000 IDU only. Selection of an option that is not licensed in your radio will cause the IDU to operate in the NTSC default mode.

---

24. Use the **Input** pull-down menu to select the video input option required.
25. Select the **Video In2** option button and observe the **Video In** screen 2 is displayed. [See Figure 5-156.](#)

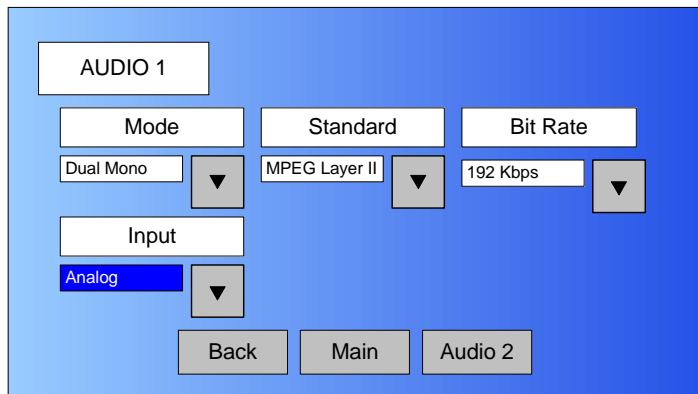
26. Select the **Noise Reduction** option button for **On** or **Off**, as required.
27. Select the **SDI Auto Line** option button for **On** or **Off**, as required.
28. Select the **HD Test Pattern** option button for **On** or **Off**, as required.
29. Select the **Back** option button and observe the **Video In** screen is displayed.
30. Select the **Back** option button and observe the **MPEG** screen is displayed. [See Figure 5-157 on page 5-65.](#)

Figure 5-157: MPEG Screen - Typical



31. Select the **Audio In** option button and observe the **AUDIO 1** screen is displayed. See Figure 5-158.

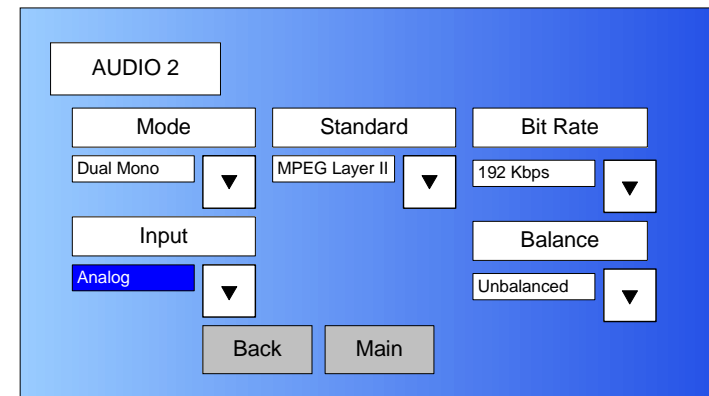
Figure 5-158: AUDIO 1 Screen - Typical



32. Use the **Mode** pull-down menu to select **Stereo** or **Dual Mono**, as required.
33. Use the **Standard** pull-down menu to select **Off**, **MPEG Layer II**, **Linear PCM**, or **MPEG Layer I**, as required.

34. Use the **Bit Rate** pull-down menu to select **128 Kbps**, **160 Kbps**, **192 Kbps**, **224 Kbps**, **256 Kbps**, **320 Kbps**, or **384 Kbps**, as required.
35. Use the **Input** pull-down menu to select **Test Tone**, **Analog**, or **SDI Emb**, as required.
36. Select the **Audio 2** option button and observe the **AUDIO 2** screen is displayed. See Figure 5-159.

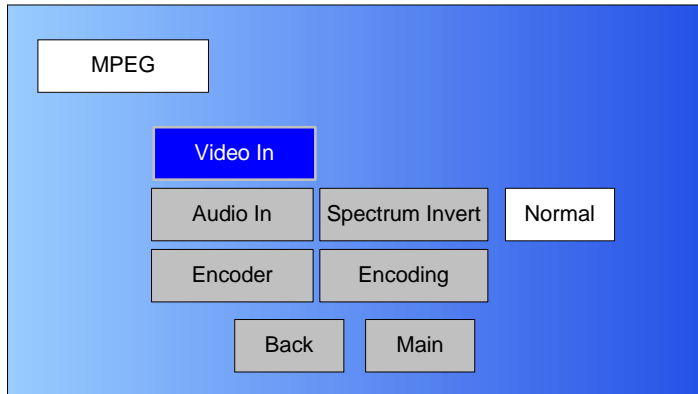
Figure 5-159: AUDIO 2 Screen - Typical



37. Use the **Mode** pull-down menu to select **Stereo** or **Dual Mono**, as required.
38. Use the **Standard** pull-down menu to select **Off**, **MPEG Layer II**, **Linear PCM**, or **MPEG Layer I**, as required.
39. Use the **Bit Rate** pull-down menu to select **128 Kbps**, **160 Kbps**, **192 Kbps**, **224 Kbps**, **256 Kbps**, **320 Kbps**, or **384 Kbps**, as required.
40. Use the **Input** pull-down menu to select **Test Tone**, **Analog**, **SDI Emb**, **AES-EBU**, or **Channel Ide**, as required.
41. Use the **Balance** pull-down menu to select **Unbalanced** or **Balanced**, as required.

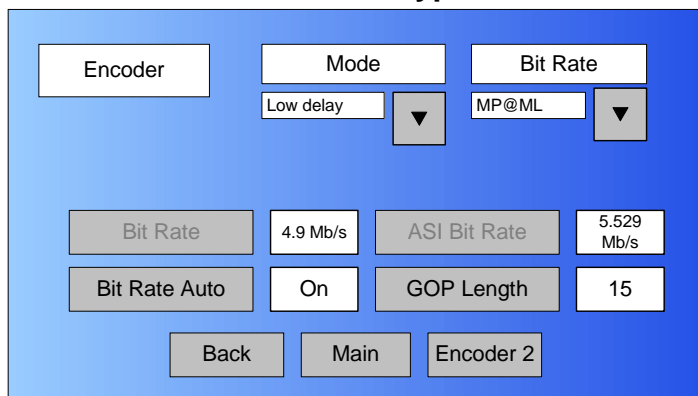
42. Select the **Back** option button and observe the **AUDIO 1** screen is displayed.
43. Select the **Back** option button and observe the **MPEG** screen is displayed. See [Figure 5-160](#).

**Figure 5-160: MPEG Screen - Typical**



44. Select the **Spectrum Invert** option button to select **Normal** or **Inverted**, as required.
45. Select the **Encoder** option button and observe the **Encoder** screen is displayed. See [Figure 5-161](#).

**Figure 5-161: Encoder Screen - Typical**



46. Select the **Mode** pull-down menu and select **Standard** or **Low delay**, as required.
47. Select the **Bit Rate** pull-down menu and select **MP@ML** or **422P@ML**, as required.

---

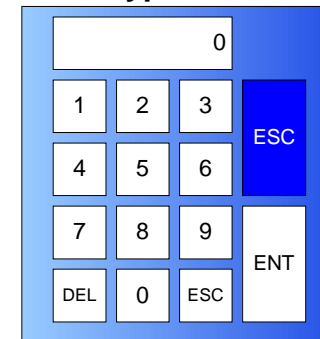
**Notes** In the following step, if the **Bit Rate Auto** option button **On** option is selected, the **Bit Rate** option button will be inactive (greyed out). Go to [step 50](#).

If the **Bit Rate Auto** option button **Off** option is selected, the **Bit Rate** option button will be active. Go to [step 49](#).

---

48. Select the **Bit Rate Auto** option button for **Off** or **On**, as required.
49. Observe the **Bit Rate** option button is active. Select the **Bit Rate** option button and observe the numeric keypad is displayed. See [Figure 5-162](#).

**Figure 5-162: Numeric Keypad**

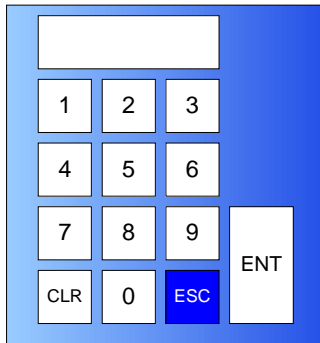


50. Enter the bit rate required, select the **ENT** key, and observe the **Encoder** screen is displayed.



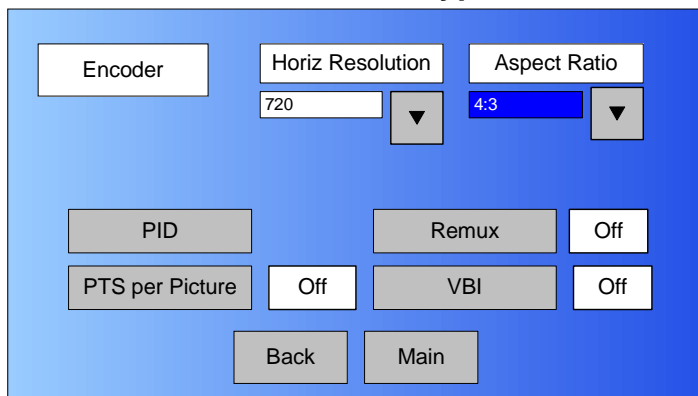
51. Select the **GOP Length** option button and observe the numeric keypad is displayed. See [Figure 5-163](#).

**Figure 5-163: Numeric Keypad**



52. Enter the Group of Pictures (GOP) number required, select the **ENT** key, and observe the **Encoder** screen is displayed.
53. Select the **Encoder 2** option button and observe the **Encoder** screen is displayed. See [Figure 5-164](#).

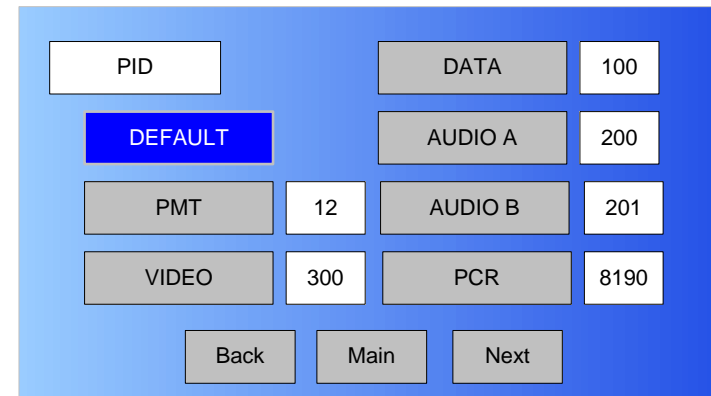
**Figure 5-164: Encoder Screen 2 - Typical**



54. Select the **Horiz Resolution** pull-down menu and select **720, 704, 544, 528, 480, or 352**, as required.

55. Select the **Aspect Ratio** pull-down menu and select **4:3 or 16:9**, as required.
56. Select the **PID** option button and observe the **PID** screen is displayed. See [Figure 5-165](#).

**Figure 5-165: PID Screen - Typical**




---

**Notes** To select the default PID settings, go to [step 57](#).

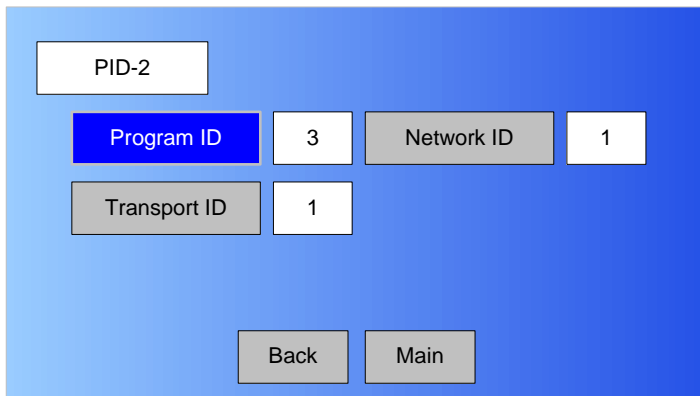
To enter individual PID settings, go to [step 58](#).

---

57. Select the **DEFAULT** option button and observe the default PID settings are displayed. Go to [step 78](#).
58. Select the **DATA** option button and observe the numeric keypad is displayed.
59. Enter the **DATA** PID required, select the **ENT** key, and observe the **PID** screen is displayed.
60. Select the **AUDIO A** option button and observe the numeric keypad is displayed.
61. Enter the **AUDIO A** PID required, select the **ENT** key, and observe the **PID** screen is displayed.

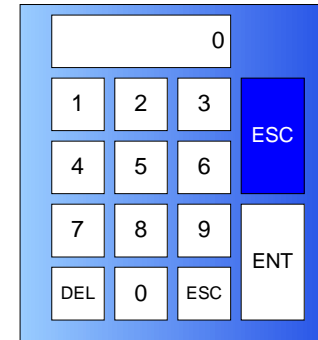
62. Select the **PMT** option button and observe the numeric keypad is displayed.
63. Enter the **PMT** PID required, select the **ENT** key, and observe the **PID** screen is displayed.
64. Select the **AUDIO B** option button and observe the numeric keypad is displayed.
65. Enter the **AUDIO B** PID required, select the **ENT** key, and observe the **PID** screen is displayed.
66. Select the **VIDEO** option button and observe the numeric keypad is displayed.
67. Enter the **Video** PID required, select the **ENT** key, and observe the **PID** screen is displayed.
68. Select the **PCR** option button and observe the numeric keypad is displayed.
69. Enter the **PCR** PID required, select the **ENT** key, and observe the **PID** screen is displayed.
70. Select the **Next** option button and observe the **PID-2** screen is displayed. See Figure 5-166.

**Figure 5-166: PID-2 Screen - Typical**



71. Select the **Program ID** option button and observe the numeric keypad is displayed. See Figure 5-167.

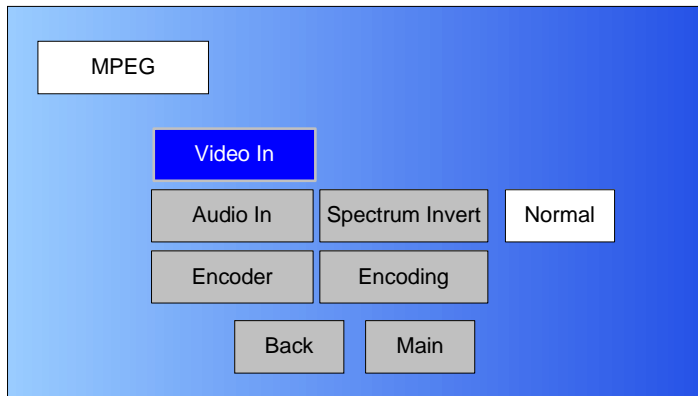
**Figure 5-167: Numeric Keypad**



72. Enter the **Program ID** PID required, select the **ENT** key, and observe the **PID-2** screen is displayed.
73. Select the **Network ID** option button and observe the numeric keypad is displayed.
74. Enter the **Network ID** PID required, select the **ENT** key, and observe the **PID-2** screen is displayed.
75. Select the **Transport ID** option button and observe the numeric keypad is displayed.
76. Enter the **Transport ID** PID required, select the **ENT** key, and observe the **PID-2** screen is displayed.
77. Select the **Back** option button and observe the **PID** screen is displayed.
78. Select the **Back** option button and observe the **Encoder** screen is displayed.
79. Select the **Remux** option button for **On** or **Off**, as required.
80. Select the **PTS per Picture** option button to select **On** or **Off**, as required.
81. Select the **VBI** option button for **On** or **Off**, as required.
82. Select the **Back** option button and observe the **Encoder** screen is displayed.

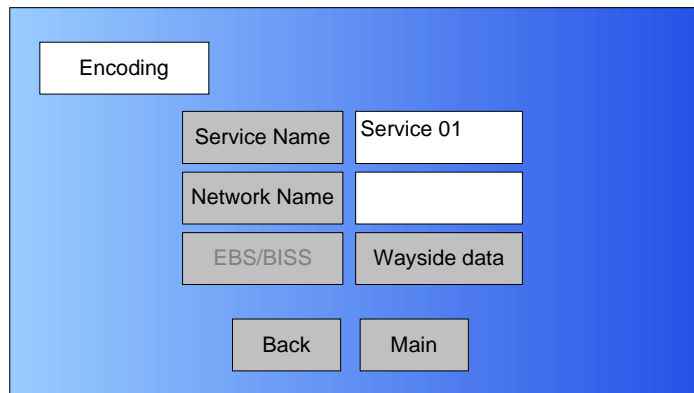
83. Select the **Back** option button and observe the **MPEG** screen is displayed. See [Figure 5-168](#).

**Figure 5-168: MPEG Screen - Typical**



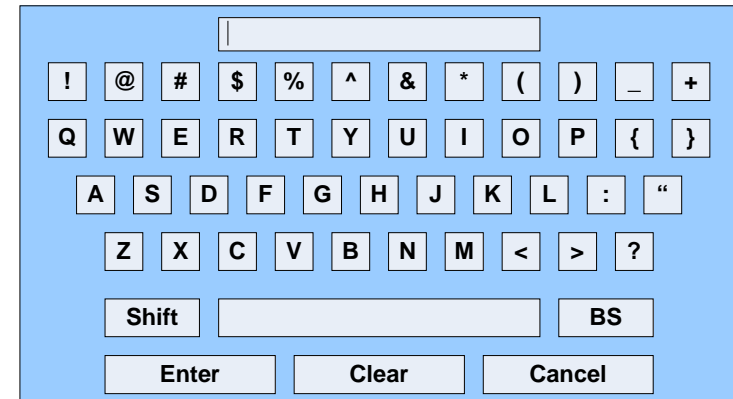
84. Select the **Encoding** option button and observe the **Encoding** screen is displayed. See [Figure 5-169](#).

**Figure 5-169: Encoding Screen - Typical**



85. Select the **Service Name** option button and observe the keyboard screen is displayed. See [Figure 5-170](#).

**Figure 5-170: Keyboard Screen**



86. Enter the service name required, select the **Enter** key, and observe the **Encoding** screen is displayed.
87. Select the **Network Name** option button and observe the keyboard screen is displayed.
88. Enter the network name required, select the **Enter** key, and observe the **Encoding** screen is displayed.

---

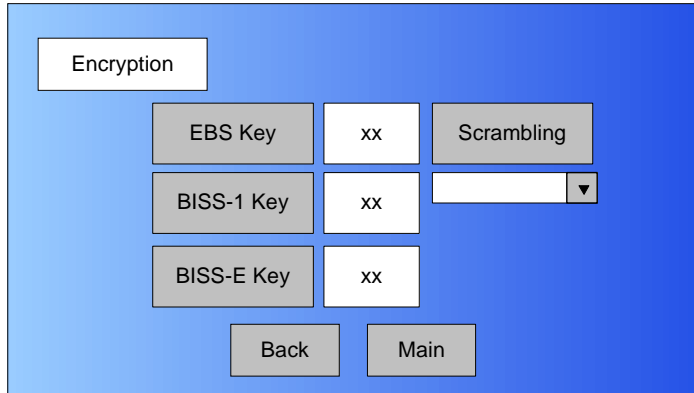
**Notes** If your MTX5000 IDU contains a licensed EBS or BISS encryption option, go to [step 89](#).

If your MTX5000 IDU does not contain a licensed EBS or BISS encryption option, go to [step 95](#).

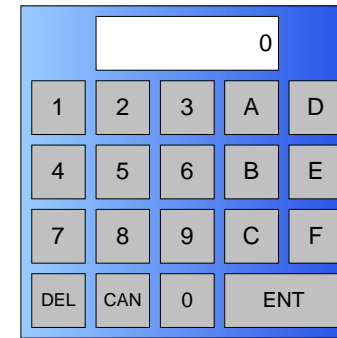
---

89. Observe the **EBS/BISS** option button is active (not greyed-out).
90. Select the **EBS/BISS** option button and observe the **Encryption** screen is displayed. See [Figure 5-171 on page 5-70](#).

**Figure 5-171: Encryption Screen**



**Figure 5-172: Alphanumeric Keypad**



---

**Notes** You can only have one licensed encryption option contained in your MTX5000 IDU.

When the **Scrambling** pull-down menu **EBS**, **BISS-1**, or **BISS-E** option is selected in the following step, the selected option key will be active, but the two remaining option buttons will become inactive (greyed-out).

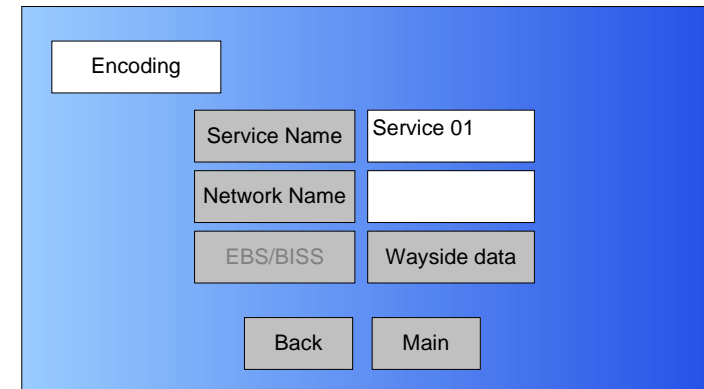
91. Select the **Scrambling** pull-down menu **EBS**, **BISS-1**, or **BISS-E** option, as required, and observe the selected **EBS**, **BISS-1**, or **BISS-E Key** option button is active.
92. Select the **EBS**, **BISS-1**, or **BISS-E Key** option button, as required, and observe the alphanumeric keypad is displayed. [See Figure 5-172.](#)

---

**Note** When the **Encryption** screen is displayed and the encryption key is entered in the following step, the encryption key will not be displayed.

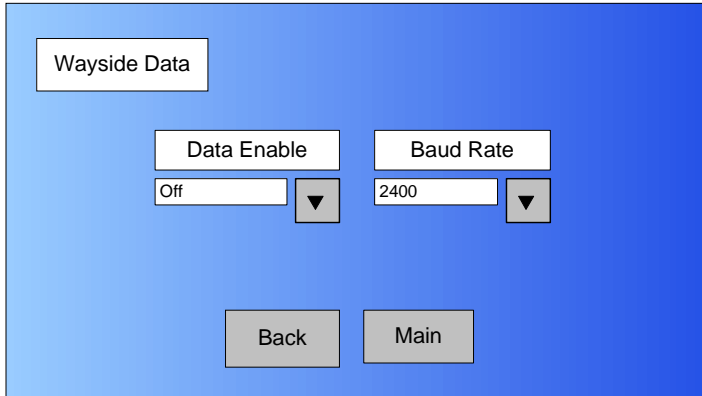
93. Enter your encryption key, select the **ENT** key, and observe the **Encryption** screen is displayed.
94. Select the **Back** option button and observe the **Encoding** screen is displayed. [See Figure 5-173.](#)

**Figure 5-173: Encoding Screen - Typical**



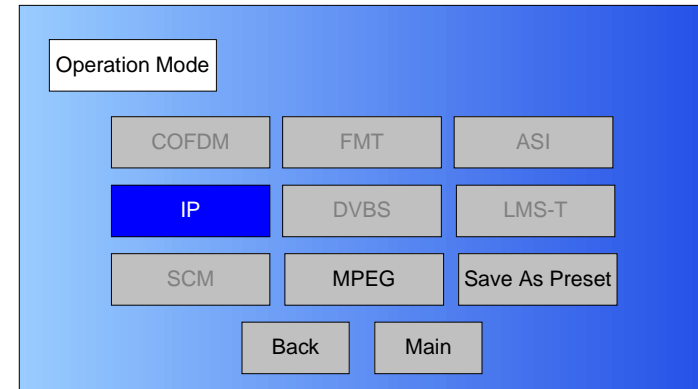
95. Select the **Wayside data** option button and observe the **Wayside Data** screen is displayed. See [Figure 5-174](#).

**Figure 5-174: Wayside Data Screen - Typical**



96. Select the **Data Enable** pull-down menu and select the **Off**, **TTV Format**, **CJM2 Format**, or **Low Delay CJM2** option, as required.
97. Select the **Baud Rate** pull-down menu and select the **1200**, **2400**, **4800**, **9600**, **19200**, or **38400** option, as required.
98. Select the **Back** option button and observe the **Encoding** screen is displayed.
99. Select the **Back** option button and observe the **MPEG** screen is displayed.
100. Select the **Back** option button and observe the **Operation Mode** screen is displayed. See [Figure 5-175](#).

**Figure 5-175: Operation Mode Screen**



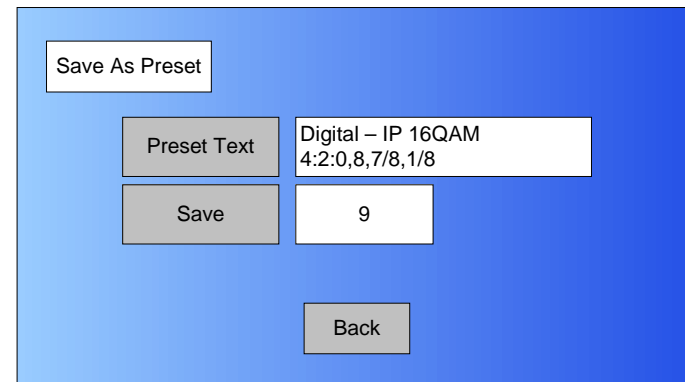

---

**Note** When the **Save As Preset** screen is displayed in the following step, the **Preset Text** and **Save** text boxes will display the name and identification of the digital IP Preset currently being used as the digital IP “make-from” for this custom Preset.

---

101. Select the **Save As Preset** option button and observe the **Save As Preset** screen is displayed. See [Figure 5-176](#).

**Figure 5-176: Save As Preset Screen - Typical**



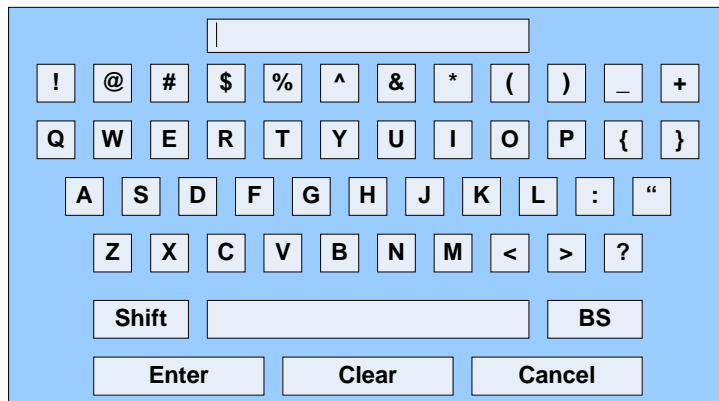
---

**Notes** In the following steps, if a factory default digital IP Preset was used as a “make-from” to prepare this custom Preset, the **Preset Text** text box and the **Save** text box *must be* changed. **You cannot change or overwrite any factory default Presets!**

If a custom digital IP Preset was used as a “make-from” to prepare this custom Preset, a brief description of the custom Preset must be entered in the **Preset Text** text box for easy identification purposes.

- 
102. Select the **Preset Text** option button and observe the keyboard screen is displayed. See Figure 5-177.

**Figure 5-177: Keyboard Screen**



103. Enter a unique digital IP Preset description, as required, and select the **Enter** key.
104. Observe the **Save As Preset** screen is displayed and the **Preset Text** text box displays the Preset description.

---

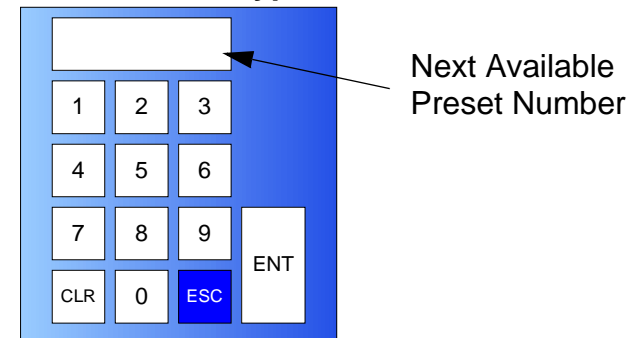
**Notes** When saving the new custom digital IP Preset in the following step, the Preset number will automatically be increased to the next available Preset number to avoid overwriting an existing Preset.

If you wish to overwrite the existing Preset number (unless it is a factory default Preset), enter the Preset number to be overwritten. A warning message will be displayed asking “**Are you sure?**”. Select the **Yes** option button.

Once an existing custom Preset is overwritten, it cannot be recovered. It must be re-entered from scratch.

- 
105. Select the **Save** option button and observe the numeric keypad is displayed. See Figure 5-178.

**Figure 5-178: Numeric Keypad**



---

**Notes** When saving Presets in the following steps, **Preset A** thru **Preset J** are factory default Presets. The factory default Preset numbers cannot be changed.

---

---

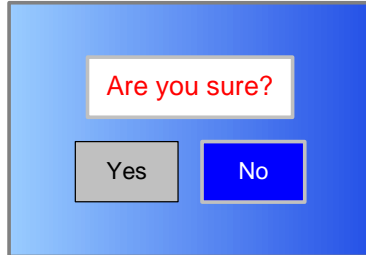
**Notes** To change the default Preset number, perform [step 106](#) and go to [step 107](#).

To accept the next available Preset number, go to [step 107](#).

---

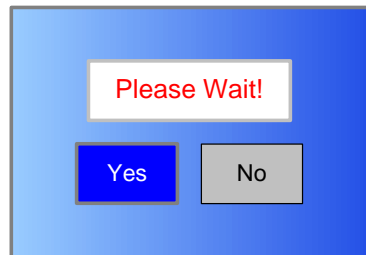
106. Select the **CLR** key and enter the Preset number required.
107. Select the **ENT** key and observe the **Are you sure?** confirmation screen is displayed. [See Figure 5-179](#).

**Figure 5-179: Confirmation Screen**



108. Select the **YES** option button and observe the **Please Wait!** message box is displayed. [See Figure 5-180](#).

**Figure 5-180: Please Wait Message Box**



109. After a short delay, observe the **Save As Preset** screen is displayed.
110. Select the **Main** option button and observe the Main screen is displayed.

## 5.5 Create or Update Preset Configuration Settings in Remote Mode

The procedures required to create or update Preset configuration settings in the Remote mode using a remote PC are contained in the following paragraphs. Preset configuration settings may be created or updated for the following types of Presets:

- Analog FMT Presets
- Digital COFDM Presets
- Digital ASI Presets
- Digital LMS-T Presets
- Digital DVB-S Presets
- Digital IP Presets.

**Please note that an External IF In Preset is available for normal operation using the factory default External IF In Preset, but no configuration settings may be made to this Preset.** No procedures are therefore applicable or are provided for External IF In Presets.

### 5.5.1 Create or Update Custom Analog Preset Configuration in Remote Mode

The procedure required to create a new custom user analog Preset configuration or to update an existing user Preset configuration in the Remote mode is contained in the following steps.

When preparing a new analog Preset, you must first select an existing analog Preset from either one of the analog factory default Presets or from your custom user analog Presets. The selected Preset will be used as a “make-from” to prepare the new user analog Preset configuration.

Please note that while factory default analog Presets may be used to prepare a new Preset configuration, these **factory default Presets cannot be changed or deleted**. They can only be used as “make-froms”.

When the new configuration is prepared using the factory default Preset, it cannot be saved with the factory Preset number or Preset name. A new Preset number and Preset name must be assigned to the new Preset.

When using a custom user Preset as a “make-from”, the new Preset should be saved with a new Preset number.

If you select an existing user Preset number when saving the new Preset, the original custom Preset will be overwritten and cannot be recovered. The only way to restore a Preset that has been overwritten is to re-enter the custom Preset data from scratch.

If you are updating configuration settings on an existing custom user Preset, when you save the configuration settings, the Preset number will automatically be increased to the next available Preset number. You must enter and save the configuration settings using the original Preset number.

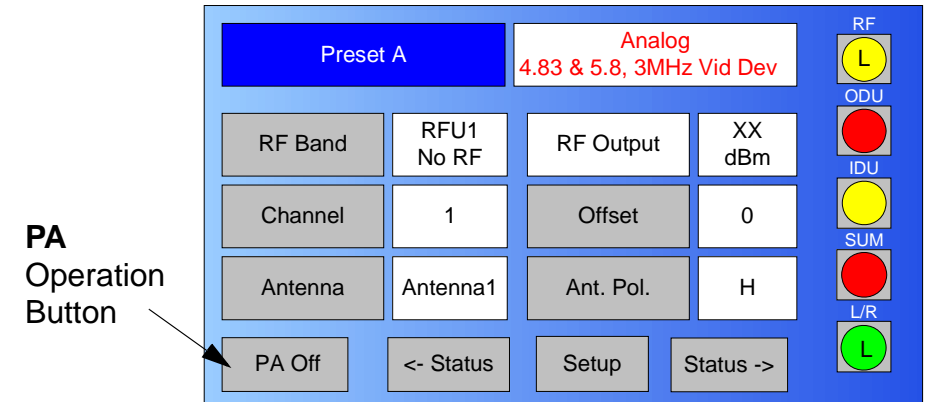
---

**Note** In the following steps, the color LCD display option buttons and pull-down menu options may be selected using either the touch screen or the function keys and the **SEL** key.

---

1. Verify the MTX5000 IDU is powered up. See ["Powering the MTX5000 System"](#) on page 3-7.
2. Observe the Main screen is displayed. See [Figure 5-181](#).

**Figure 5-181: Main Screen - Typical**



3. Select the **L/R** option button for **L** (Local), as required.
4. Select the **PA** operation button for **PA Off**, as required
5. Select the **Setup** option button and observe the **Setup** screen is displayed.
6. Select the **Radio** option button and observe the **Radio** screen is displayed.
7. Select the **Next** option button and observe the **Radio - 2** screen is displayed.
8. Select the **Remote Ctrl Option** button and observe the **Select Remote Ctrl Opt** screen is displayed.
9. Select the **Remote** option button and observe the **Radio - 2** screen is displayed.
10. Select the **Main** option button, observe the Main screen is displayed, and observe the **L/R** option button indicates **R** (Remote).



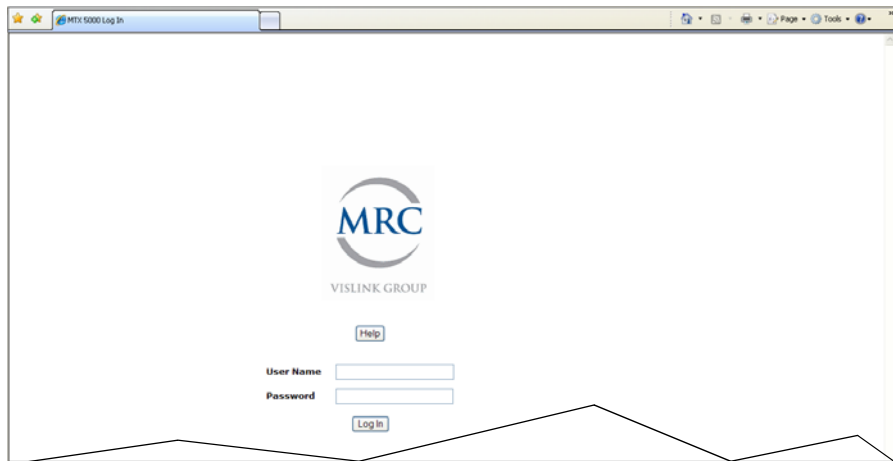
**Note** In the following step, **XXX.XXX.X.XX** is the IP address of your MTX5000 IDU.

- At the remote PC, open your web browser, enter the IP address for your MTX5000 IDU, and press the keyboard **Enter** key. The IP address should be entered as follows:

**http://XXX.XXX.X.XX/nfs/main/html**

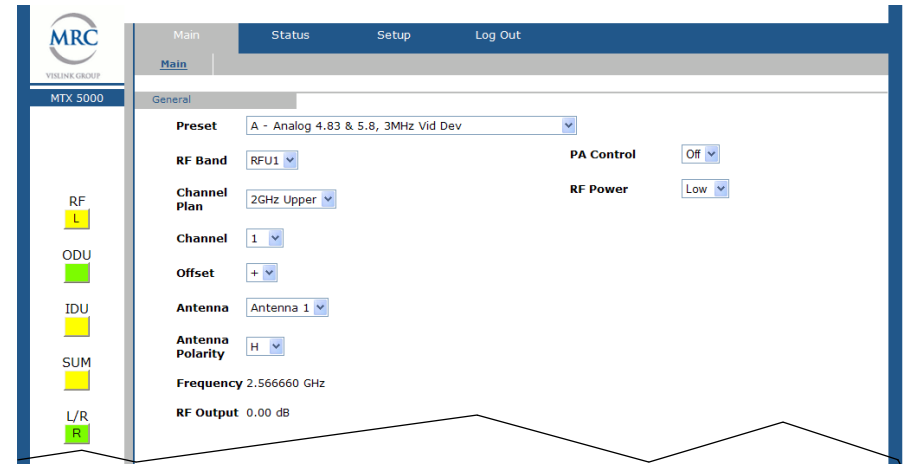
- After a short delay, observe the remote log in screen is displayed. See Figure 5-182.

**Figure 5-182: Remote Log In Screen - Typical**



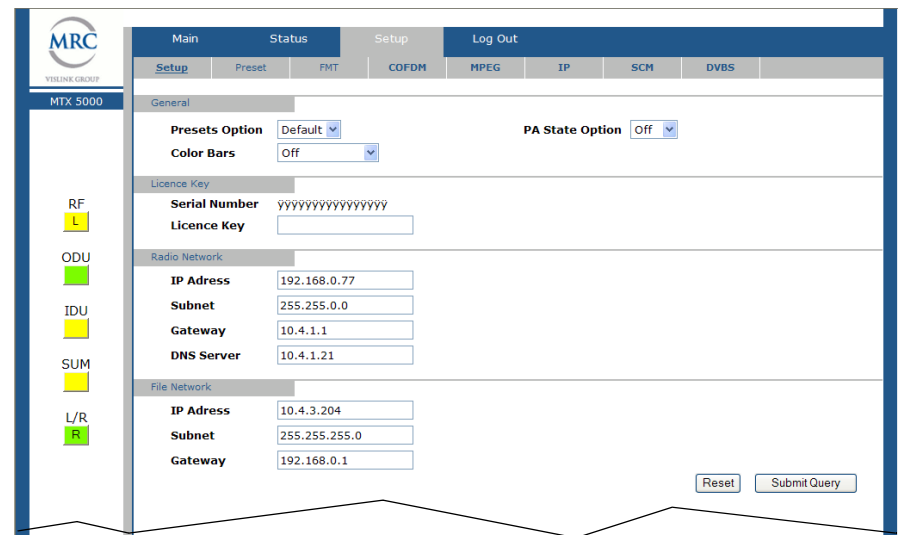
- Enter your administrator user name in the **User Name** text box, enter your administrator password in the **Password** text box, select the **Log In** option button, and observe the **MTX5000 Main Page** is displayed. See Figure 5-183.

**Figure 5-183: MTX5000 Main Page - Typical**



- Select the **Setup** tab and observe the **Setup** page is displayed by default. See Figure 5-184.

**Figure 5-184: Setup Tab - Typical**



---

**Note** In the following step, if a factory default analog Preset is to be used to prepare a new Preset configuration, select the **Default** option.

If a custom user Preset is to be updated or is to be used to prepare a new Preset, select the **User** option.

---

15. Use the **Presets Option** pull-down menu and select **Default** or **User**, as required.
16. Use the **Color Bars** pull-down menu and select **Off**, **On**, **Auto Gen**, or **Auto Standby**, as required.
17. Use the **PA State Option** pull-down menu to select **Off** or **Last**, as required.
18. Select the **Submit** option button.
19. Select the **Main** tab and observe the **Main** page is displayed.
20. Use the **Preset** pull-down menu to select the default or user custom analog Preset required.
21. Select the **Setup** tab and observe the **Setup** page is displayed.
22. Select the **FMT** tab and observe the **FMT** page is displayed.
23. Use the **Video Deviation** pull-down menu to select **3 MHz** or **4 MHz**, as required.
24. Use the **Video Input** pull-down menu to select **Composite** or **Baseband**, as required.

---

**Note** Repeat [step 25](#) thru [step 27](#) for **Audio CH1** thru **Audio CH4**, as required.

---

25. Use the **Enable** pull-down menu to select **On** or **Off**, as required.
26. Use the **Pre-Emphasis** pull-down menu to select **On** or **Off**, as required.

---

**Note** In the following step, the **Frequency** pull-down menus have 11 frequency options and a **Custom** option.

If the **Custom** option is selected, a frequency text box will be displayed adjacent to the pull-down menu.

---

27. Use the **Frequency** pull-down menu to select the frequency option required or select **Custom**.  
  
If **Custom** is selected, enter the frequency required in the active text box(es), as required. Frequency range is 4830 to 8590 kHz.
28. When **Audio CH1** thru **Audio CH4** options have all been selected, select the **Submit** option button.
29. Select the **Preset** tab and observe the **Preset** page is displayed.

---

**Notes** In the following steps, if a factory **Default** analog Preset was used as a “make-from” to prepare this custom Preset, the **Preset Text** text box and the **Preset Number** text box *must be* changed. **You cannot change or overwrite any factory default Presets!**

If a custom **User** analog Preset was used as a “make-from” to prepare this custom Preset, a brief description of the custom Preset should be entered in the **Preset Text** text box for easy identification purposes. The Preset number must be changed only if you do not wish to overwrite the custom Preset.

- 
30. Select the **Preset Text** text box and enter a unique analog Preset description.

---

**Note** If you used a factory **Default** Preset or a custom **User** Preset as a “make-from” and you want to add the new Preset to the list of **User** Presets contained in your MTX5000 IDU, you must know the highest user Preset number contained in your IDU. To add the new Preset to the list of **User** Presets, go to [step 31](#).

If you used a custom **User** Preset as a “make-from” and you want to use it to replace (overwrite) an existing custom **User** Preset, go to [step 33](#).

- 
31. Select the **Preset Number** text box and enter any Preset number that is higher than the current highest user Preset number in your MTX5000 IDU.

32. Select the **Submit** option button and observe that the **Preset Number** automatically displays the next higher Preset number available in the Preset **User** list. Go to [step 34](#).
33. Select the **Preset Number** text box, enter the Preset number that you wish to overwrite, and select the **Submit** option button.
34. Observe the new Preset configuration has been loaded into the MTX5000 IDU and the new Preset name and Preset number are displayed on the Main page.

## 5.5.2 Create or Update Custom Digital COFDM Preset Configuration in Remote Mode

The procedure required to create a new custom digital COFDM Preset configuration or to update an existing Preset configuration in the Remote mode is contained in the following steps.

When preparing a new user digital COFDM Preset, you must first select an existing digital COFDM Preset from either one of the digital COFDM factory default Presets or from your own custom digital COFDM Presets. The selected Preset will be used as a “make-from” to prepare the new digital COFDM Preset configuration.

Please note that while factory default digital COFDM Presets may be used to prepare a new Preset configuration, these **factory default Presets cannot be changed or deleted**. They can only be used as “make-froms”.

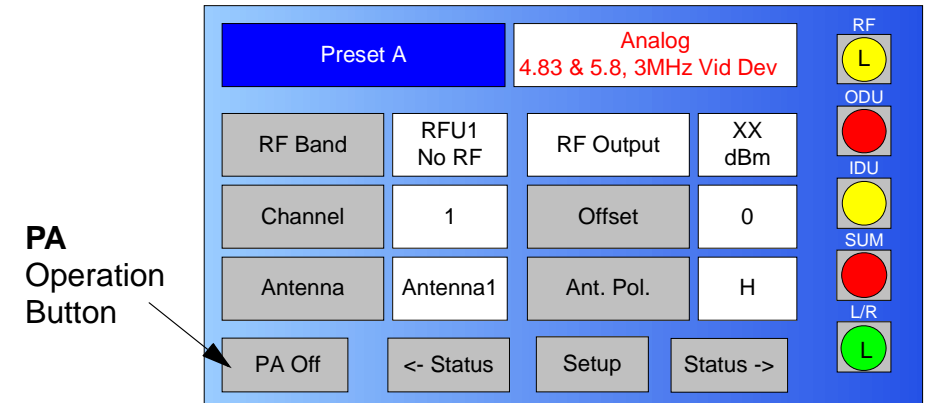
When the new configuration is prepared using the factory default Preset, it cannot be saved with the factory Preset number or Preset name. A new Preset number and Preset name must be assigned to the new Preset.

When using a custom user Preset as a “make-from”, the new Preset should be saved with a new Preset number.

If you select an existing user Preset number when saving the new Preset, the original custom Preset will be overwritten and cannot be recovered. The only way to restore a Preset that has been overwritten is to re-enter the custom Preset data from scratch.

If you are updating configuration settings on an existing custom Preset, when you save the configuration settings, the Preset number will automatically be increased to the next available Preset number. You must enter and save the configuration settings using the original Preset number.

**Figure 5-185: Main Screen - Typical**




---

**Note** In the following steps, the color LCD display option buttons and pull-down menu options may be selected using either the touch screen or the function keys and the **SEL** key.

---

1. Verify the MTX5000 IDU is powered up. See ["Powering the MTX5000 System"](#) on page 3-7.
2. Observe the Main screen is displayed. See [Figure 5-185](#).

3. Select the **L/R** option button for **L** (Local), as required.
4. Select the **PA** operation button for **PA Off**, as required
5. Select the **Setup** option button and observe the **Setup** screen is displayed.
6. Select the **Radio** option button and observe the **Radio** screen is displayed.
7. Select the **Next** option button and observe the **Radio - 2** screen is displayed.
8. Select the **Remote Ctrl Option** button and observe the **Select Remote Ctrl Opt** screen is displayed.
9. Select the **Remote** option button and observe the **Radio - 2** screen is displayed.
10. Select the **Main** option button, observe the Main screen is displayed, and observe the **L/R** option button indicates **R** (Remote).

---

**Note** In the following step, **XXX.XXX.X.XX** is the IP address of your MTX5000 IDU.

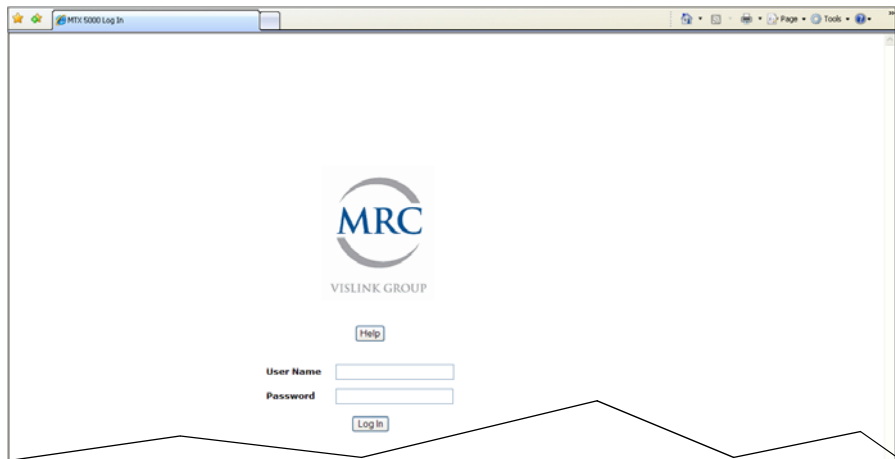
---

- At the remote PC, open your web browser, enter the IP address for your MTX5000 IDU, and press the keyboard **Enter** key. The IP address should be entered as follows:

**http://XXX.XXX.X.XX/nfs/main/html**

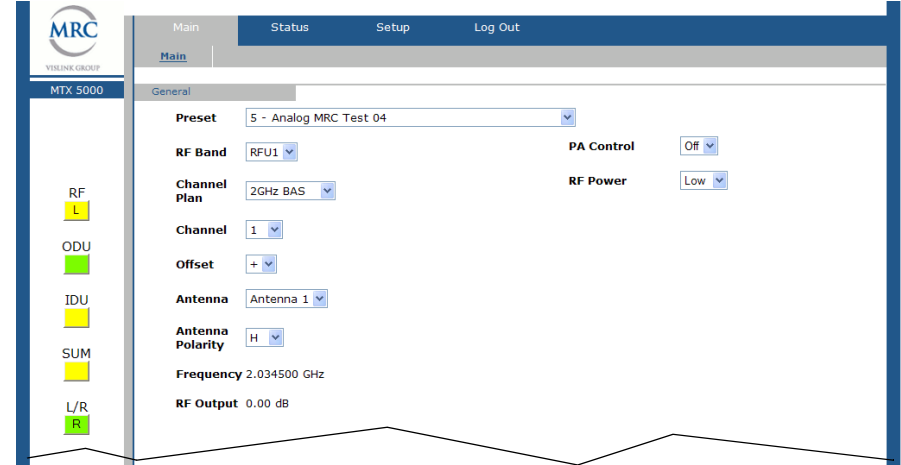
- After a short delay, observe the remote log in screen is displayed. See Figure 5-186.

**Figure 5-186: Remote Log In Screen - Typical**



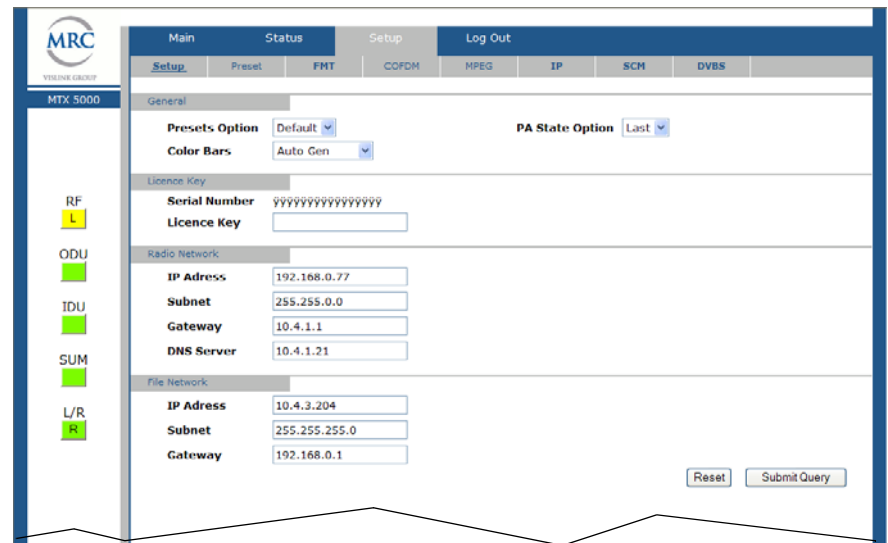
- Enter your administrator user name in the **User Name** text box, enter your administrator password in the **Password** text box, select the **Log In** option button, and observe the **MTX5000 Main Page** is displayed. See Figure 5-187.

**Figure 5-187: MTX5000 Main Page - Typical**



- Select the **Setup** tab and observe the **Setup** page is displayed by default. See Figure 5-188.

**Figure 5-188: Setup Tab - Typical**



---

**Note** In the following step, if a factory default digital COFDM Preset is to be used to prepare a new Preset configuration, select the **Default** option.

If a custom user digital COFDM Preset is to be updated or is to be used to prepare a new Preset, select the **User** option.

---

15. Use the **Presets Option** pull-down menu and select **Default** or **User**, as required.
  16. Use the **Color Bars** pull-down menu and select **Off**, **On**, **Auto Gen**, or **Auto Standby**, as required.
  17. Use the **PA State Option** pull-down menu to select **Off** or **Last**, as required, and select the **Submit** option button.
  18. Select the **Main** tab and observe the **Main** page is displayed.
  19. Use the **Preset** pull-down menu to select the default or user custom digital COFDM Preset required.
  20. Select the **Setup** tab and observe the **Setup** page is displayed.
  21. Select the **COFDM** tab and observe the **COFDM** page is displayed.
  22. Use the **Constellation** pull-down menu to select **QPSK**, **16-QAM**, or **64-QAM**, as required.
  23. Use the **FEC** pull-down menu to select **1/2**, **2/3**, **3/4**, **5/6**, or **7/8**, as required.
  24. Use the **Guard Interval** pull-down menu to select **1/32**, **1/16**, **1/8**, or **1/4**, as required.
  25. Use the **RF B/W** pull-down menu to select **6 MHz**, **7 MHz**, **8 MHz**, **10 MHz**, or **20 MHz**, as required.
  26. Select the **Submit** option button.
  27. Select the **MPEG** tab and observe the **MPEG** page is displayed.
  28. Use the **General - Spectrum Invert** pull-down menu to select **Normal** or **Inverted**, as required.
  29. Use the **Video In - Input** pull-down menu to select the input required.
  30. Use the **Video Input - Noise Reduction** pull-down menu to select **On** or **Off**, as required.
  31. Use the **Video Input - SDI Autoline** pull-down menu to select **On** or **Off**, as required.
  32. Use the **Video Input - HD Test Pattern** pull-down menu to select **On** or **Off**, as required.
  33. Use the **Audio 1 - Mode** pull-down menu to select **Dual Mono** or **Stereo**, as required.
  34. Use the **Audio 1 - Input** pull-down menu to select **Test Tone**, **Analog**, **SDI Emb**, **AES-EBU** or **Channel Ident**, as required.
  35. Use the **Audio 1 - Standard** pull-down menu to select **Off**, **MPEG Layer II**, **Linear PCM**, or **MPEG Layer I**, as required.
  36. Use the **Audio 1 - Bit Rate** pull-down menu to select the bit rate required.
  37. Use the **Audio 2 - Mode** pull-down menu to select **Dual Mono** or **Stereo**, as required.
  38. Use the **Audio 2 - Input** pull-down menu to select **Test Tone**, **Analog**, **SDI Emb**, **AES-EBU** or **Channel Ident**, as required.
  39. Use the **Audio 2 - Standard** pull-down menu to select **Off**, **MPEG Layer II**, **Linear PCM**, or **MPEG Layer I**, as required.
  40. Use the **Audio 2 - Bit Rate** pull-down menu to select the bit rate required.
-

41. Use the **Audio 2 - Balance** pull-down menu to select **Unbalanced** or **Balanced**, as required.
42. Use the **Encoder - Mode** pull-down menu to select **Standard** or **Low Delay**, as required.
43. Use the **Encoder - Bit Rate** text box to enter the bit rate required.
44. Use the **Encoder - Bit Rate Auto** pull-down menu to select **On** or **Off**, as required.
45. Use the **Encoder - PTS per Picture** pull-down menu to select **On** or **Off**, as required.
46. Use the **Encoder - Horiz Resolution** pull-down menu to select **720**, **704**, **544**, **480** or **352**, as required.
47. Use the **Encoder - Profile** pull-down menu to select **MP@HL** or **422P@HL**, as required.

---

**Note** In the following step, if the **Bit Rate Auto** pull-down menu option selected was **On**, the **ASI Bit Rate** text box is inactive and cannot be changed. Go to [step 49](#).

If the **Bit Rate Auto** pull-down menu option selected was **Off**, the **ASI Bit Rate** text box is active and the bit rate can be changed.

- 
48. Select the **Encoder - ASI Bit Rate** text box and enter the bit rate required.

---

**Note** In the following step, if the **Remux** pull-down menu **On** option is selected, the **Bit Rate Auto** pull-down menu will become inactive, the **ASI Bit Rate** text box becomes active, and the bit rate can be changed.

---

49. Use the **Encoder - Remux** pull-down menu to select **On** or **Off**, as required.
50. Select the **Encoder - GOP Length** text box and enter the group of pictures length required.
51. Use the **Encoder - Aspect ratio** pull-down menu to select **16:9** or **4:3**, as required.
52. Use the **Encoder - VBI** pull-down menu to select **On** or **Off**, as required.
53. Select the **PID - Video** text box and enter the program identifier, as required.
54. Select the **PID - PCR** text box and enter the program identifier, as required.
55. Select the **PID - PMT** text box and enter the program identifier, as required.
56. Select the **PID - Audio 2** text box and enter the program identifier, as required.
57. Select the **PID - Data** text box and enter the program identifier, as required.
58. Select the **PID - Audio 1** text box and enter the program identifier, as required.
59. Select the **Encoding - Service Name** text box and enter the service name, as required.
60. Select the **Encoding - Network Name** text box and enter the network name, as required.
61. Use the **Encoding - Data Enable** pull-down menu to select **Off**, **TTV Format**, **CJM2 Format**, or **Low Delay CJM2**, as required.
62. Use the **Encoding - Baud Rate** pull-down menu to select **1200**, **2400**, **4800**, **9600**, **19200**, or **38400**, as required.
63. Select the **Submit** option button.

64. Select the **Preset** tab and observe the **Preset** page is displayed.

---

**Notes** In the following steps, if a factory default digital COFDM Preset was used as a “make-from” to prepare this custom Preset, the **Preset Text** text box and the **Preset Number** text box *must be* changed. ***You cannot change or overwrite any factory default Presets!***

If a custom digital COFDM Preset was used as a “make-from” to prepare this custom Preset, a brief description of the custom Preset should be entered in the **Preset Text** text box for easy identification purposes. The Preset number must be changed only if you do not wish to overwrite the custom Preset.

- 
65. Select the **Preset Text** text box and enter a unique digital COFDM Preset description.

---

**Note** If you used a factory **Default** Preset or a custom **User** Preset as a “make-from” and you want to add the new Preset to the list of **User** Presets contained in your MTX5000 IDU, you must know the highest user Preset number contained in your IDU. To add the new Preset to the list of **User** Presets, go to [step 66](#).

If you used a custom **User** Preset as a “make-from” and you want to use it to replace (overwrite) an existing custom **User** Preset, go to [step 68](#).

---

66. Select the **Preset Number** text box and enter any Preset number that is higher than the current highest Preset in your MTX5000 IDU.
67. Select the **Submit** option button and observe that the **Preset Number** automatically displays the next higher Preset number available in the Preset **User** list. Go to [step 69](#).
68. Select the **Preset Number** text box, enter the Preset number that you wish to overwrite, and select the **Submit** option button.
69. Observe the new Preset configuration has been loaded into the MTX5000 IDU and the new Preset name and Preset number are displayed on the Main page.

### 5.5.3 Create or Update Custom Digital ASI Preset Configuration in Remote Mode

The procedure required to create a new custom digital ASI Preset configuration or to update an existing Preset configuration in the Remote mode is contained in the following steps.

When preparing a new digital ASI Preset, you must first select an existing digital ASI Preset from either the digital ASI factory default Preset or from your own custom digital ASI Presets. The selected Preset will be used as a “make-from” to prepare the new digital ASI Preset configuration.

Please note that while factory default digital ASI Presets may be used to prepare a new Preset configuration, these **factory default Presets cannot be changed or deleted**. They can only be used as “make-froms”.

When the new configuration is prepared using the factory default Preset, it cannot be saved with the factory Preset number or



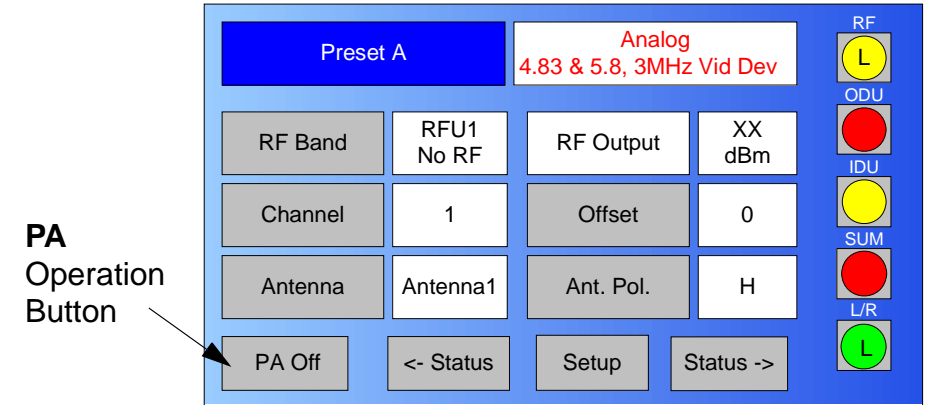
Preset name. A new Preset number and Preset name must be assigned to the new Preset.

When using a custom Preset as a “make-from”, the new Preset should be saved with a new Preset number.

If you select an existing Preset number when saving the new Preset, the original custom Preset will be overwritten and cannot be recovered. The only way to restore a Preset that has been overwritten is to re-enter the custom Preset data from scratch.

If you are updating configuration settings on an existing custom Preset, when you save the configuration settings, the Preset number will automatically be increased to the next available Preset number. You must enter and save the configuration settings using the original Preset number.

**Figure 5-189: Main Screen - Typical**



**PA**  
Operation  
Button

---

**Note** In the following steps, the color LCD display option buttons and pull-down menu options may be selected using either the touch screen or the function keys and the **SEL** key.

---

1. Verify the MTX5000 IDU is powered up. See ["Powering the MTX5000 System" on page 3-7](#).
2. Observe the Main screen is displayed. See [Figure 5-189](#).

3. Select the **L/R** option button for **L** (Local), as required.
4. Select the **PA** operation button for **PA Off**, as required
5. Select the **Setup** option button and observe the **Setup** screen is displayed.
6. Select the **Radio** option button and observe the **Radio** screen is displayed.
7. Select the **Next** option button and observe the **Radio - 2** screen is displayed.
8. Select the **Remote Ctrl Option** button and observe the **Select Remote Ctrl Opt** screen is displayed.
9. Select the **Remote** option button and observe the **Radio - 2** screen is displayed.
10. Select the **Main** option button, observe the Main screen is displayed, and observe the **L/R** option button indicates **R** (Remote).

---

**Note** In the following step, **XXX.XXX.X.XX** is the IP address of your MTX5000 IDU.

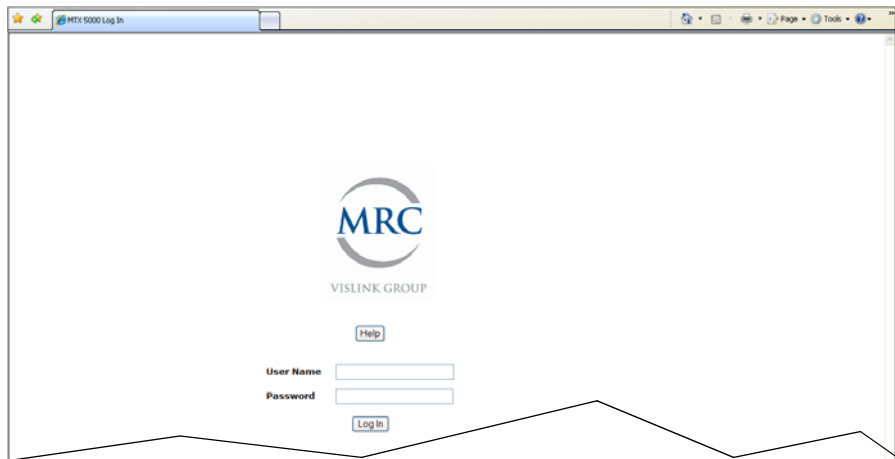
---

- At the remote PC, open your web browser, enter the IP address for your MTX5000 IDU, and press the keyboard **Enter** key. The IP address should be entered as follows:

**http://XXX.XXX.X.XX/nfs/main/html**

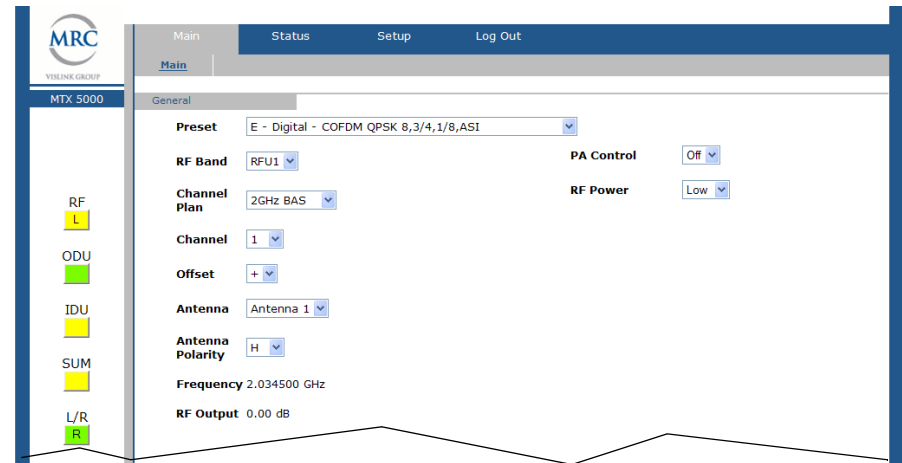
- After a short delay, observe the remote log in screen is displayed. See Figure 5-190.

**Figure 5-190: Remote Log In Screen - Typical**



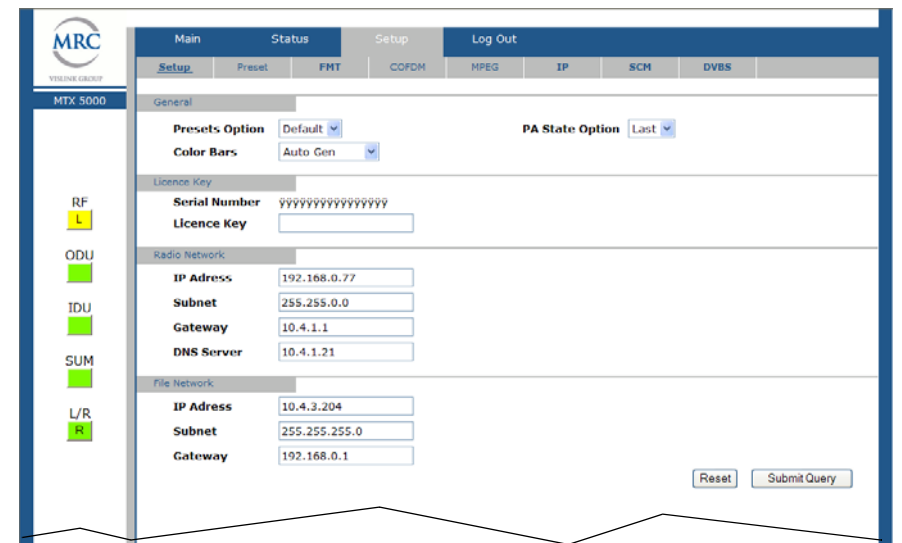
- Enter your administrator user name in the **User Name** text box, enter your administrator password in the **Password** text box, select the **Log In** option button, and observe the **MTX5000 Main Page** is displayed. See Figure 5-191.

**Figure 5-191: MTX5000 Main Page - Typical**



- Select the **Setup** tab and observe the **Setup** page is displayed by default. See Figure 5-192.

**Figure 5-192: Setup Tab - Typical**



---

**Note** In the following step, if a factory default digital ASI Preset is to be used to prepare a new Preset configuration, select the **Default** option.

If a custom digital ASI Preset is to be updated or is to be used to prepare a new Preset, select the **User** option.

---

15. Use the **Presets Option** pull-down menu and select **Default** or **User**, as required.
16. Use the **Color Bars** pull-down menu and select **Off**, **On**, **Auto Gen**, or **Auto Standby**, as required.
17. Use the **PA State Option** pull-down menu to select **Off** or **Last**, as required, and select the **Submit** option button.
18. Select the **Main** tab and observe the **Main** page is displayed.
19. Use the **Preset** pull-down menu to select the default or user custom digital ASI Preset required.
20. Select the **Setup** tab and observe the **Setup** page is displayed.
21. Select the **COFDM** tab and observe the **COFDM** page is displayed.
22. Use the **Constellation** pull-down menu to select **QPSK**, **16-QAM**, or **64-QAM**, as required.
23. Use the **FEC** pull-down menu to select **1/2**, **2/3**, **3/4**, **5/6**, or **7/8**, as required.
24. Use the **Guard Interval** pull-down menu to select **1/32**, **1/16**, **1/8**, or **1/4**, as required.
25. Use the **RF B/W** pull-down menu to select **6 MHz**, **7 MHz**, **8 MHz**, **10 MHz**, or **20 MHz**, as required.

26. Select the **Submit** option button.
27. Select the **Preset** tab and observe the **Preset** page is displayed.

---

**Notes** In the following steps, if a factory default digital ASI Preset was used as a “make-from” to prepare this custom Preset, the **Preset Text** text box and the **Preset Number** text box *must be* changed. **You cannot change or overwrite any factory default Presets!**

If a custom digital ASI Preset was used as a “make-from” to prepare this custom Preset, a brief description of the custom Preset should be entered in the **Preset Text** text box for easy identification purposes. The Preset number must be changed only if you do not wish to overwrite the custom Preset.

---

28. Select the **Preset Text** text box and enter a unique digital ASI Preset description.
- 

**Note** If you used a factory **Default** Preset or a custom **User** Preset as a “make-from” and you want to add the new Preset to the list of **User** Presets contained in your MTX5000 IDU, you must know the highest user Preset number contained in your IDU. To add the new Preset to the list of **User** Presets, go to [step 29](#).

If you used a custom **User** Preset as a “make-from” and you want to use it to replace (overwrite) an existing custom **User** Preset, go to [step 31](#).

---

29. Select the **Preset Number** text box and enter any Preset number that is higher than the current highest Preset in your MTX5000 IDU.
30. Select the **Submit** option button and observe that the **Preset Number** automatically displays the next higher Preset number available in the Preset **User** list. Go to [step 32](#).
31. Select the **Preset Number** text box, enter the Preset number that you wish to overwrite, and select the **Submit** option button.
32. Observe the new Preset configuration has been loaded into the MTX5000 IDU and the new Preset name and Preset number are displayed on the Main page.

#### 5.5.4 Create or Update Custom Digital LMS-T Preset Configuration in Remote Mode

The procedure required to create a new custom digital LMS-T Preset configuration or to update an existing Preset configuration in the Remote mode is contained in the following steps.

When preparing a new digital LMS-T Preset, you must first select an existing digital LMS-T Preset from either one of the digital LMS-T factory default Presets or from your own custom digital LMS-T Presets. The selected Preset will be used as a “make-from” to prepare the new digital LMS-T Preset configuration.

Please note that while factory default digital LMS-T Presets may be used to prepare a new Preset configuration, these **factory default Presets cannot be changed or deleted**. They can only be used as “make-froms”.

When the new configuration is prepared using the factory default Preset, it cannot be saved with the factory Preset number or

Preset name. A new Preset number and Preset name must be assigned to the new Preset.

When using a custom Preset as a “make-from”, the new Preset should be saved with a new Preset number.

If you select an existing Preset number when saving the new Preset, the original custom Preset will be overwritten and cannot be recovered. The only way to restore a Preset that has been overwritten is to re-enter the custom Preset data from scratch.

If you are updating configuration settings on an existing custom Preset, when you save the configuration settings, the Preset number will automatically be increased to the next available Preset number. You must enter and save the configuration settings using the original Preset number.

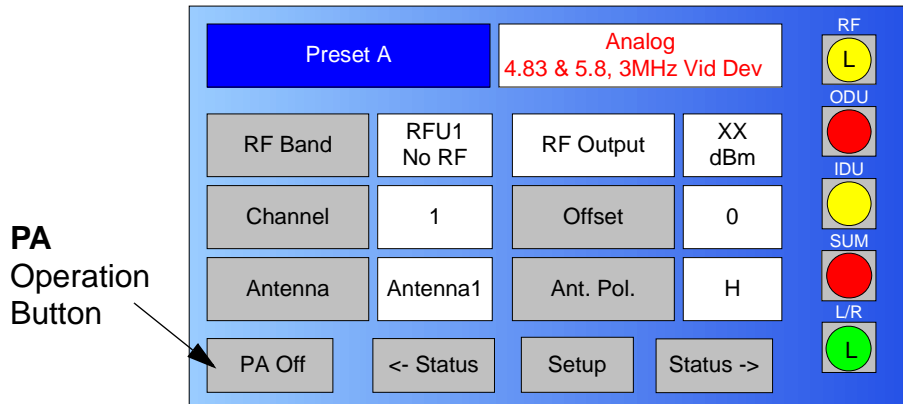
---

<b>Note</b>	In the following steps, the color LCD display option buttons and pull-down menu options may be selected using either the touch screen or the function keys and the <b>SEL</b> key.
-------------	--

---

1. Verify the MTX5000 IDU is powered up. [See "Powering the MTX5000 System" on page 3-7.](#)
2. Observe the Main screen is displayed. [See Figure 5-193 on page 5-87.](#)

**Figure 5-193: Main Screen - Typical**



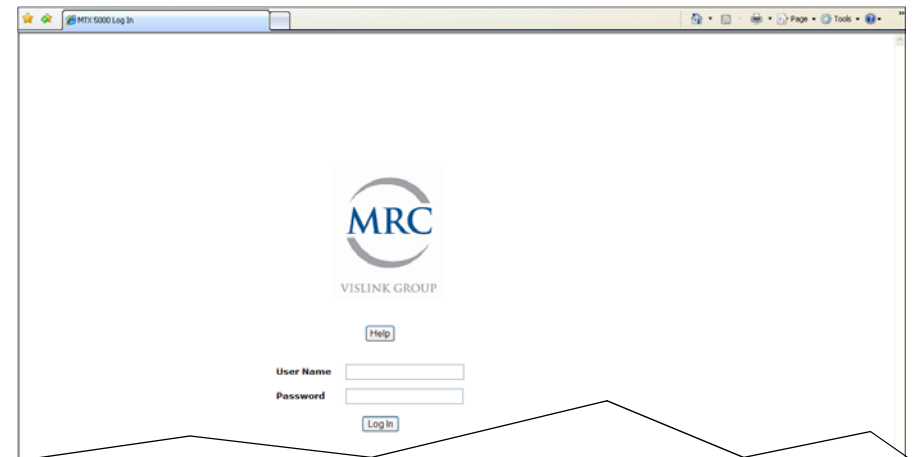
3. Select the **L/R** option button for **L** (Local), as required.
4. Select the **PA** operation button for **PA Off**, as required
5. Select the **Setup** option button and observe the **Setup** screen is displayed.
6. Select the **Radio** option button and observe the **Radio** screen is displayed.
7. Select the **Next** option button and observe the **Radio - 2** screen is displayed.
8. Select the **Remote Ctrl Option** button and observe the **Select Remote Ctrl Opt** screen is displayed.
9. Select the **Remote** option button and observe the **Radio - 2** screen is displayed.
10. Select the **Main** option button, observe the Main screen is displayed, and observe the **L/R** option button indicates **R** (Remote).

11. At the remote PC, open your web browser, enter the IP address for your MTX5000 IDU, and press the keyboard **Enter** key. The IP address should be entered as follows:

**http://XXX.XXX.X.XX/nfs/main/html**

12. After a short delay, observe the remote log in screen is displayed. See Figure 5-194.

**Figure 5-194: Remote Log In Screen - Typical**



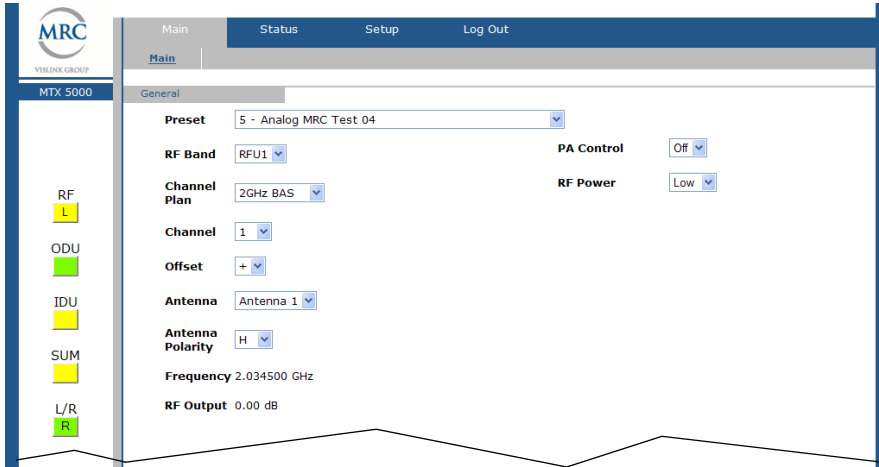
13. Enter your administrator user name in the **User Name** text box, enter your administrator password in the **Password** text box, select the **Log In** option button, and observe the **MTX50000 Main Page** is displayed. See Figure 5-195 on page 5-88.

---

**Note** In the following step, **XXX.XXX.X.XX** is the IP address of your MTX5000 IDU.

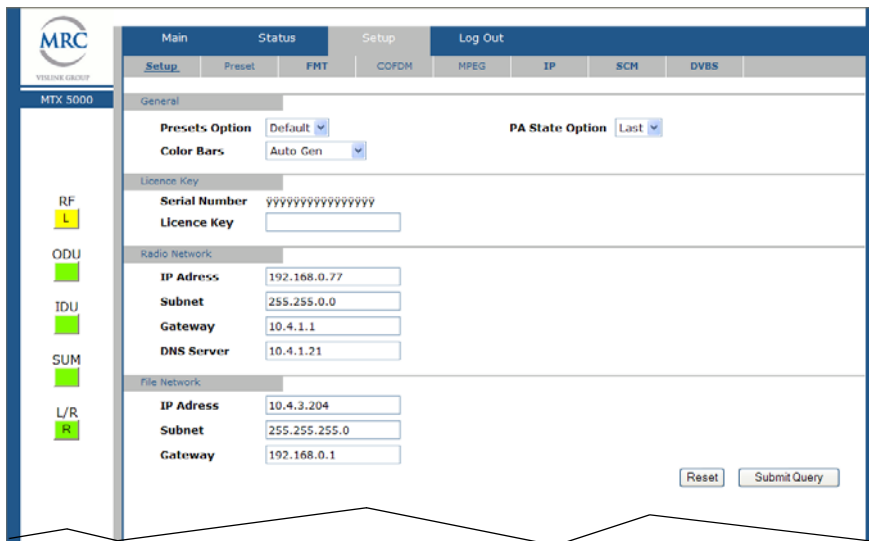
---

**Figure 5-195: MTX5000 Main Page - Typical**



14. Select the **Setup** tab and observe the **Setup** page is displayed by default. See Figure 5-196.

**Figure 5-196: Setup Tab - Typical**



**Note** In the following step, if a factory default digital LMS-T Preset is to be used to prepare a new Preset configuration, select the **Default** option.

If a custom digital LMS-T Preset is to be updated or is to be used to prepare a new Preset, select the **User** option.

15. Use the **Presets Option** pull-down menu and select **Default** or **User**, as required.
16. Use the **Color Bars** pull-down menu and select **Off**, **On**, **Auto Gen**, or **Auto Standby**, as required.
17. Use the **PA State Option** pull-down menu to select **Off** or **Last**, as required, and select the **Submit** option button.
18. Select the **Main** tab and observe the **Main** page is displayed.
19. Use the **Preset** pull-down menu to select the default or user custom digital LMS-T Preset required.
20. Select the **Setup** tab and observe the **Setup** page is displayed.
21. Select the **COFDM** tab and observe the **COFDM** page is displayed.
22. Use the **Constellation** pull-down menu to select **QPSK**, **16-QAM**, or **64-QAM**, as required.
23. Use the **FEC** pull-down menu to select **1/2**, **2/3**, **3/4**, **5/6**, or **7/8**, as required.
24. Use the **Guard Interval** pull-down menu to select **1/32**, **1/16**, **1/8**, or **1/4**, as required.
25. Use the **RF B/W** pull-down menu to select **6 MHz**, **7 MHz**, **8 MHz**, **10 MHz**, or **20 MHz**, as required.

26. Select the **Submit** option button.
27. Select the **MPEG** tab and observe the **MPEG** page is displayed.
28. Use the **General - Spectrum Invert** pull-down menu to select **Normal** or **Inverted**, as required.
29. Use the **Video In - Input** pull-down menu to select the input required.
30. Use the **Video Input - Noise Reduction** pull-down menu to select **On** or **Off**, as required.
31. Use the **Video Input - SDI Autoline** pull-down menu to select **On** or **Off**, as required.
32. Use the **Video Input - HD Test Pattern** pull-down menu to select **On** or **Off**, as required.
33. Use the **Audio 1 - Mode** pull-down menu to select **Dual Mono** or **Stereo**, as required.
34. Use the **Audio 1 - Input** pull-down menu to select **Test Tone, Analog, SDI Emb, AES-EBU** or **Channel Ident**, as required.
35. Use the **Audio 1 - Standard** pull-down menu to select **Off, MPEG Layer II, Linear PCM, or MPEG Layer I**, as required.
36. Use the **Audio 1 - Bit Rate** pull-down menu to select the bit rate required.
37. Use the **Audio 2 - Mode** pull-down menu to select **Dual Mono** or **Stereo**, as required.
38. Use the **Audio 2 - Input** pull-down menu to select **Test Tone, Analog, SDI Emb, AES-EBU** or **Channel Ident**, as required.
39. Use the **Audio 2 - Standard** pull-down menu to select **Off, MPEG Layer II, Linear PCM, or MPEG Layer I**, as required.
40. Use the **Audio 2 - Bit Rate** pull-down menu to select the bit rate required.
41. Use the **Audio 2 - Balance** pull-down menu to select **Unbalanced** or **Balanced**, as required.
42. Use the **Encoder - Mode** pull-down menu to select **Standard** or **Low Delay**, as required.
43. Use the **Encoder - Bit Rate** text box to enter the bit rate required.
44. Use the **Encoder - Bit Rate Auto** pull-down menu to select **On** or **Off**, as required.
45. Use the **Encoder - PTS per Picture** pull-down menu to select **On** or **Off**, as required.
46. Use the **Encoder - Horiz Resolution** pull-down menu to select **720, 704, 544, 480** or **352**, as required.
47. Use the **Encoder - Profile** pull-down menu to select **MP@HL** or **422P@HL**, as required.

---

**Note** In the following step, if the **Bit Rate Auto** pull-down menu option selected was **On**, the **ASI Bit Rate** text box is inactive and cannot be changed. Go to [step 49](#).

If the **Bit Rate Auto** pull-down menu option selected was **Off**, the **ASI Bit Rate** text box is active and the bit rate can be changed.

---

48. Select the **Encoder - ASI Bit Rate** text box and enter the bit rate required.

---

**Note** In the following step, if the **Remux** pull-down menu **On** option is selected, the **Bit Rate Auto** pull-down menu will become inactive, the **ASI Bit Rate** text box becomes active, and the bit rate can be changed.

---

49. Use the **Encoder - Remux** pull-down menu to select **On** or **Off**, as required.
50. Select the **Encoder - GOP Length** text box and enter the group of pictures length required.
51. Use the **Encoder - Aspect ratio** pull-down menu to select **16:9** or **4:3**, as required.
52. Use the **Encoder - VBI** pull-down menu to select **On** or **Off**, as required.
53. Select the **PID - Video** text box and enter the program identifier, as required.
54. Select the **PID - PCR** text box and enter the program identifier, as required.
55. Select the **PID - PMT** text box and enter the program identifier, as required.
56. Select the **PID - Audio 2** text box and enter the program identifier, as required.
57. Select the **PID - Data** text box and enter the program identifier, as required.
58. Select the **PID - Audio 1** text box and enter the program identifier, as required.
59. Select the **Encoding - Service Name** text box and enter the service name, as required.
60. Select the **Encoding - Network Name** text box and enter the network name, as required.

61. Use the **Encoding - Data Enable** pull-down menu to select **Off**, **TTV Format**, **CJM2 Format**, or **Low Delay CJM2**, as required.
62. Use the **Encoding - Baud Rate** pull-down menu to select **1200**, **2400**, **4800**, **9600**, **19200**, or **38400**, as required.
63. Select the **Submit** option button.
64. Select the **Preset** tab and observe the **Preset** page is displayed.

---

**Notes** In the following steps, if a factory default digital LMS-T Preset was used as a “make-from” to prepare this custom Preset, the **Preset Text** text box and the **Preset Number** text box **must be** changed. ***You cannot change or overwrite any factory default Presets!***

If a custom digital LMS-T Preset was used as a “make-from” to prepare this custom Preset, a brief description of the custom Preset should be entered in the **Preset Text** text box for easy identification purposes. The Preset number must be changed only if you do not wish to overwrite the custom Preset.

---

65. Select the **Preset Text** text box and enter a unique digital LMS-T Preset description.



---

**Note** If you used a factory **Default** Preset or a custom **User** Preset as a “make-from” and you want to add the new Preset to the list of **User** Presets contained in your MTX5000 IDU, you must know the highest user Preset number contained in your IDU. To add the new Preset to the list of **User** Presets, go to [step 66](#).

If you used a custom **User** Preset as a “make-from” and you want to use it to replace (overwrite) an existing custom **User** Preset, go to [step 68](#).

---

66. Select the **Preset Number** text box and enter any Preset number that is higher than the current highest Preset in your MTX5000 IDU.
67. Select the **Submit** option button and observe that the **Preset Number** automatically displays the next higher Preset number available in the Preset **User** list. Go to [step 69](#).
68. Select the **Preset Number** text box, enter the Preset number that you wish to overwrite, and select the **Submit** option button.
69. Observe the new Preset configuration has been loaded into the MTX5000 IDU and the new Preset name and Preset number are displayed on the Main page.

### 5.5.5 Create or Update Custom Digital DVB-S Preset Configuration in Remote Mode

The procedure required to create a new custom digital DVB-S Preset configuration or to update an existing Preset configuration in the Remote mode is contained in the following steps.

When preparing a new digital DVB-S Preset, you must first select an existing digital DVB-S Preset from either the digital DVB-S factory default Preset or from your own custom digital DVB-S Presets. The selected Preset will be used as a “make-from” to prepare the new digital DVB-S Preset configuration.

Please note that while factory default digital DVB-S Presets may be used to prepare a new Preset configuration, these **factory default Presets cannot be changed or deleted**. They can only be used as “make-froms”.

When the new configuration is prepared using the factory default Preset, it cannot be saved with the factory Preset number or Preset name. A new Preset number and Preset name must be assigned to the new Preset.

When using a custom Preset as a “make-from”, the new Preset should be saved with a new Preset number.

If you select an existing Preset number when saving the new Preset, the original custom Preset will be overwritten and cannot be recovered. The only way to restore a Preset that has been overwritten is to re-enter the custom Preset data from scratch.

If you are updating configuration settings on an existing custom Preset, when you save the configuration settings, the Preset number will automatically be increased to the next available Preset number. You must enter and save the configuration settings using the original Preset number.

---

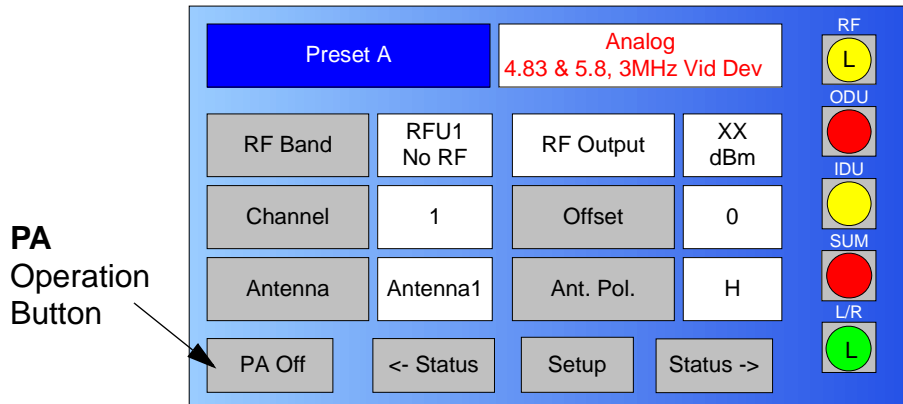
**Note** In the following steps, the color LCD display option buttons and pull-down menu options may be selected using either the touch screen or the function keys and the **SEL** key.

---

1. Verify the MTX5000 IDU is powered up. [See “Powering the MTX5000 System” on page 3-7](#).

2. Observe the Main screen is displayed. See Figure 5-197.

**Figure 5-197: Main Screen - Typical**



3. Select the **L/R** option button for **L** (Local), as required.
4. Select the **PA** operation button for **PA Off**, as required
5. Select the **Setup** option button and observe the **Setup** screen is displayed.
6. Select the **Radio** option button and observe the **Radio** screen is displayed.
7. Select the **Next** option button and observe the **Radio - 2** screen is displayed.
8. Select the **Remote Ctrl Option** button and observe the **Select Remote Ctrl Opt** screen is displayed.
9. Select the **Remote** option button and observe the **Radio - 2** screen is displayed.
10. Select the **Main** option button, observe the Main screen is displayed, and observe the **L/R** option button indicates **R** (Remote).

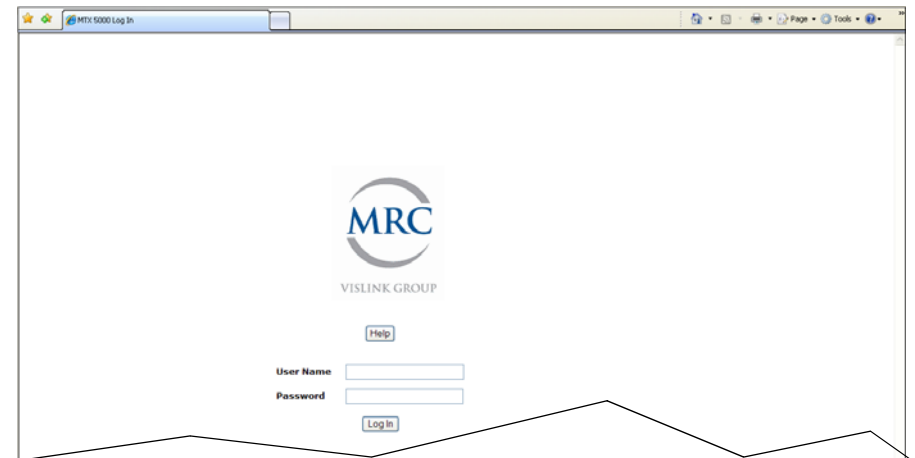
---

**Note** In the following step, **XXX.XXX.X.XX** is the IP address of your MTX5000 IDU.

---

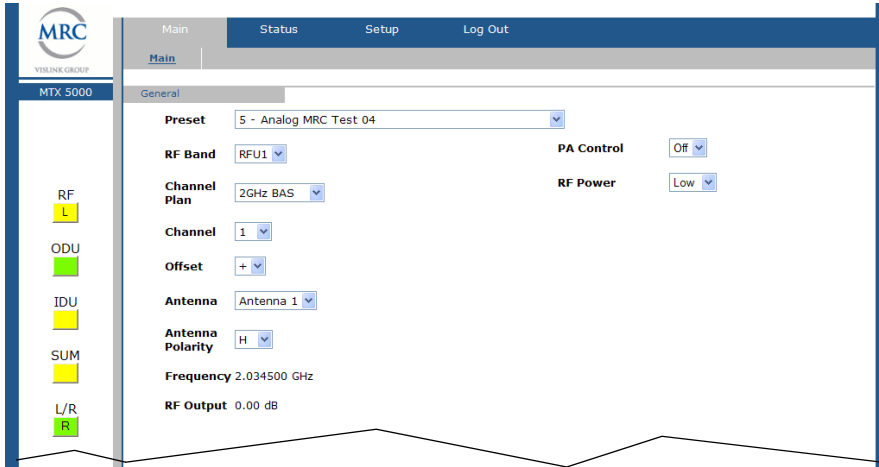
11. At the remote PC, open your web browser, enter the IP address for your MTX5000 IDU, and press the keyboard **Enter** key. The IP address should be entered as follows:  
  
**http://XXX.XXX.X.XX/nfs/main/html**
12. After a short delay, observe the remote log in screen is displayed. See Figure 5-198.

**Figure 5-198: Remote Log In Screen - Typical**



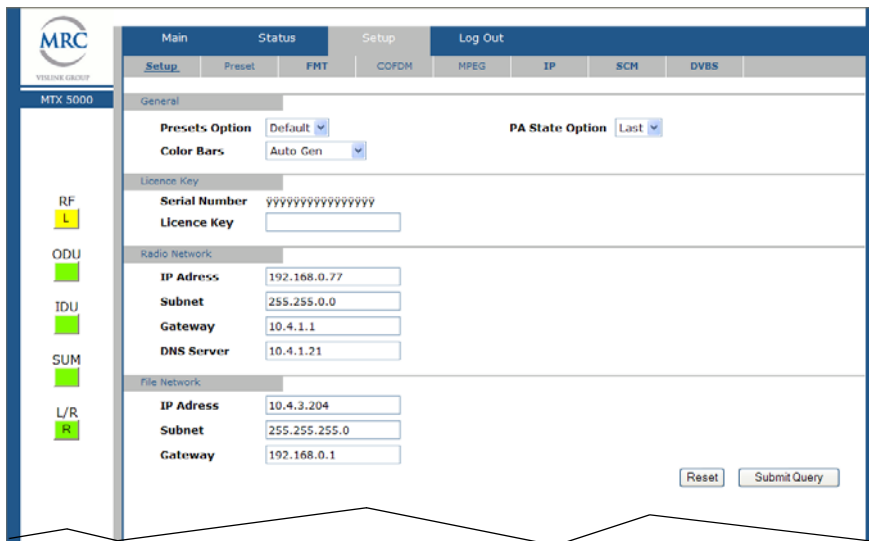
13. Enter your administrator user name in the **User Name** text box, enter your administrator password in the **Password** text box, select the **Log In** option button, and observe the **MTX50000 Main Page** is displayed. See Figure 5-199 on page 5-93.

**Figure 5-199: MTX5000 Main Page - Typical**



14. Select the **Setup** tab and observe the **Setup** page is displayed by default. See Figure 5-200.

**Figure 5-200: Setup Tab - Typical**



**Note** In the following step, if a factory default digital DVB-S Preset is to be used to prepare a new Preset configuration, select the **Default** option.

If a custom digital DVB-S Preset is to be updated or is to be used to prepare a new Preset, select the **User** option.

15. Use the **Presets Option** pull-down menu and select **Default** or **User**, as required.
16. Use the **Color Bars** pull-down menu and select **Off**, **On**, **Auto Gen**, or **Auto Standby**, as required.
17. Use the **PA State Option** pull-down menu to select **Off** or **Last**, as required, and select the **Submit** option button.
18. Select the **Main** tab and observe the **Main** page is displayed.
19. Use the **Preset** pull-down menu to select the default or user custom digital DVB-S Preset required.
20. Select the **Setup** tab and observe the **Setup** page is displayed.
21. Select the **COFDM** tab and observe the **COFDM** page is displayed.
22. Use the **Constellation** pull-down menu to select **QPSK**, **16-QAM**, or **64-QAM**, as required.
23. Use the **FEC** pull-down menu to select **1/2**, **2/3**, **3/4**, **5/6**, or **7/8**, as required.
24. Use the **Guard Interval** pull-down menu to select **1/32**, **1/16**, **1/8**, or **1/4**, as required.
25. Use the **RF B/W** pull-down menu to select **6 MHz**, **7 MHz**, **8 MHz**, **10 MHz**, or **20 MHz**, as required.
26. Select the **Submit** option button.

27. Select the **MPEG** tab and observe the **MPEG** page is displayed.
  28. Use the **General - Spectrum Invert** pull-down menu to select **Normal** or **Inverted**, as required.
  29. Use the **Video In - Input** pull-down menu to select the input required.
  30. Use the **Video Input - Noise Reduction** pull-down menu to select **On** or **Off**, as required.
  31. Use the **Video Input - SDI Autoline** pull-down menu to select **On** or **Off**, as required.
  32. Use the **Video Input - HD Test Pattern** pull-down menu to select **On** or **Off**, as required.
  33. Use the **Audio 1 - Mode** pull-down menu to select **Dual Mono** or **Stereo**, as required.
  34. Use the **Audio 1 - Input** pull-down menu to select **Test Tone, Analog, SDI Emb, AES-EBU** or **Channel Ident**, as required.
  35. Use the **Audio 1 - Standard** pull-down menu to select **Off, MPEG Layer II, Linear PCM**, or **MPEG Layer I**, as required.
  36. Use the **Audio 1 - Bit Rate** pull-down menu to select the bit rate required.
  37. Use the **Audio 2 - Mode** pull-down menu to select **Dual Mono** or **Stereo**, as required.
  38. Use the **Audio 2 - Input** pull-down menu to select **Test Tone, Analog, SDI Emb, AES-EBU** or **Channel Ident**, as required.
  39. Use the **Audio 2 - Standard** pull-down menu to select **Off, MPEG Layer II, Linear PCM**, or **MPEG Layer I**, as required.
  40. Use the **Audio 2 - Bit Rate** pull-down menu to select the bit rate required.
  41. Use the **Audio 2 - Balance** pull-down menu to select **Unbalanced** or **Balanced**, as required.
  42. Use the **Encoder - Mode** pull-down menu to select **Standard** or **Low Delay**, as required.
  43. Use the **Encoder - Bit Rate** text box to enter the bit rate required.
  44. Use the **Encoder - Bit Rate Auto** pull-down menu to select **On** or **Off**, as required.
  45. Use the **Encoder - PTS per Picture** pull-down menu to select **On** or **Off**, as required.
  46. Use the **Encoder - Horiz Resolution** pull-down menu to select **720, 704, 544, 480** or **352**, as required.
  47. Use the **Encoder - Profile** pull-down menu to select **MP@HL** or **422P@HL**, as required.
- 
- Note** In the following step, if the **Bit Rate Auto** pull-down menu option selected was **On**, the **ASI Bit Rate** text box is inactive and cannot be changed. Go to [step 49](#).
- If the **Bit Rate Auto** pull-down menu option selected was **Off**, the **ASI Bit Rate** text box is active and the bit rate can be changed.
- 
48. Select the **Encoder - ASI Bit Rate** text box and enter the bit rate required.
- 
- Note** In the following step, if the **Remux** pull-down menu **On** option is selected, the **Bit Rate Auto** pull-down menu will become inactive, the **ASI Bit Rate** text box becomes active, and the bit rate can be changed.
-

49. Use the **Encoder - Remux** pull-down menu to select **On** or **Off**, as required.
50. Select the **Encoder - GOP Length** text box and enter the group of pictures length required.
51. Use the **Encoder - Aspect ratio** pull-down menu to select **16:9** or **4:3**, as required.
52. Use the **Encoder - VBI** pull-down menu to select **On** or **Off**, as required.
53. Select the **PID - Video** text box and enter the program identifier, as required.
54. Select the **PID - PCR** text box and enter the program identifier, as required.
55. Select the **PID - PMT** text box and enter the program identifier, as required.
56. Select the **PID - Audio 2** text box and enter the program identifier, as required.
57. Select the **PID - Data** text box and enter the program identifier, as required.
58. Select the **PID - Audio 1** text box and enter the program identifier, as required.
59. Select the **Encoding - Service Name** text box and enter the service name, as required.
60. Select the **Encoding - Network Name** text box and enter the network name, as required.
61. Use the **Encoding - Data Enable** pull-down menu to select **Off**, **TTV Format**, **CJM2 Format**, or **Low Delay CJM2**, as required.
62. Use the **Encoding - Baud Rate** pull-down menu to select **1200**, **2400**, **4800**, **9600**, **19200**, or **38400**, as required.
63. Select the **Submit** option button.
64. Select the **DVB-S** tab and observe the **DVB-S** page is displayed.
65. Use the **Roll Off** pull-down menu to select **20%**, **25%**, or **35%**, as required.
66. Select the **Symbol Rate** text box and enter the symbol rate required.
67. Select the **Preset** tab and observe the **Preset** page is displayed.

---

**Notes** In the following steps, if a factory default digital DVB-S Preset was used as a “make-from” to prepare this custom Preset, the **Preset Text** text box and the **Preset Number** text box *must be* changed. ***You cannot change or overwrite any factory default Presets!***

If a custom digital DVB-S Preset was used as a “make-from” to prepare this custom Preset, a brief description of the custom Preset should be entered in the **Preset Text** text box for easy identification purposes. The Preset number must be changed only if you do not wish to overwrite the custom Preset.

- 
68. Select the **Preset Text** text box and enter a unique digital DVB-S Preset description.

---

**Note** If you used a factory **Default** Preset or a custom **User** Preset as a “make-from” and you want to add the new Preset to the list of **User** Presets contained in your MTX5000 IDU, you must know the highest user Preset number contained in your IDU. To add the new Preset to the list of **User** Presets, go to [step 69](#).

If you used a custom **User** Preset as a “make-from” and you want to use it to replace (overwrite) an existing custom **User** Preset, go to [step 71](#).

---

69. Select the **Preset Number** text box and enter any Preset number that is higher than the current highest Preset in your MTX5000 IDU.
70. Select the **Submit** option button and observe that the **Preset Number** automatically displays the next higher Preset number available in the Preset **User** list. Go to [step 72](#).
71. Select the **Preset Number** text box, enter the Preset number that you wish to overwrite, and select the **Submit** option button.
72. Observe the new Preset configuration has been loaded into the MTX5000 IDU and the new Preset name and Preset number are displayed on the Main page.

### 5.5.6 Create or Update Custom Digital IP Preset Configuration in Remote Mode

The procedure required to create a new custom digital IP Preset configuration or to update an existing Preset configuration in the Remote mode is contained in the following steps.

When preparing a new digital IP Preset, you must first select an existing digital IP Preset from either the digital IP factory default Preset or from your own custom digital IP Presets. The selected Preset will be used as a “make-from” to prepare the new digital IP Preset configuration.

Please note that while factory default digital IP Presets may be used to prepare a new Preset configuration, these **factory default Presets cannot be changed or deleted**. They can only be used as “make-froms”.

When the new configuration is prepared using the factory default Preset, it cannot be saved with the factory Preset number or Preset name. A new Preset number and Preset name must be assigned to the new Preset.

When using a custom Preset as a “make-from”, the new Preset should be saved with a new Preset number.

If you select an existing Preset number when saving the new Preset, the original custom Preset will be overwritten and cannot be recovered. The only way to restore a Preset that has been overwritten is to re-enter the custom Preset data from scratch.

If you are updating configuration settings on an existing custom Preset, when you save the configuration settings, the Preset number will automatically be increased to the next available Preset number. You must enter and save the configuration settings using the original Preset number.

---

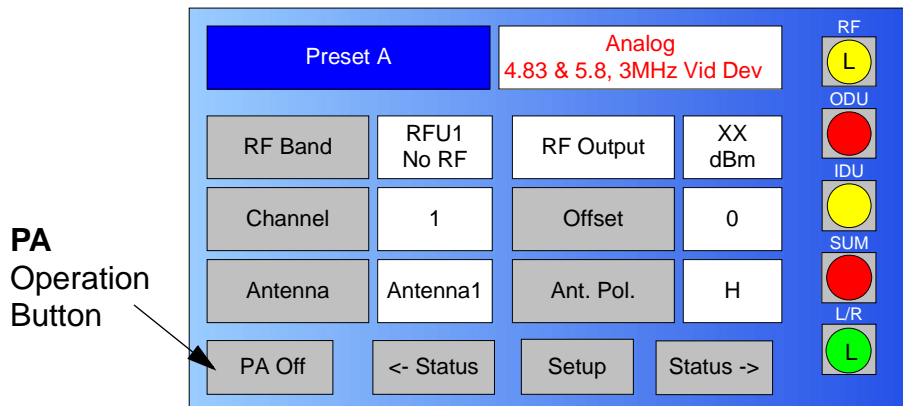
**Note** In the following steps, the color LCD display option buttons and pull-down menu options may be selected using either the touch screen or the function keys and the **SEL** key.

---

1. Verify the MTX5000 IDU is powered up. [See “Powering the MTX5000 System” on page 3-7.](#)

2. Observe the Main screen is displayed. See Figure 5-201.

**Figure 5-201: Main Screen - Typical**



3. Select the **L/R** option button for **L** (Local), as required.
4. Select the **PA** operation button for **PA Off**, as required
5. Select the **Setup** option button and observe the **Setup** screen is displayed.
6. Select the **Radio** option button and observe the **Radio** screen is displayed.
7. Select the **Next** option button and observe the **Radio - 2** screen is displayed.
8. Select the **Remote Ctrl Option** button and observe the **Select Remote Ctrl Opt** screen is displayed.
9. Select the **Remote** option button and observe the **Radio - 2** screen is displayed.
10. Select the **Main** option button, observe the Main screen is displayed, and observe the **L/R** option button indicates **R** (Remote).

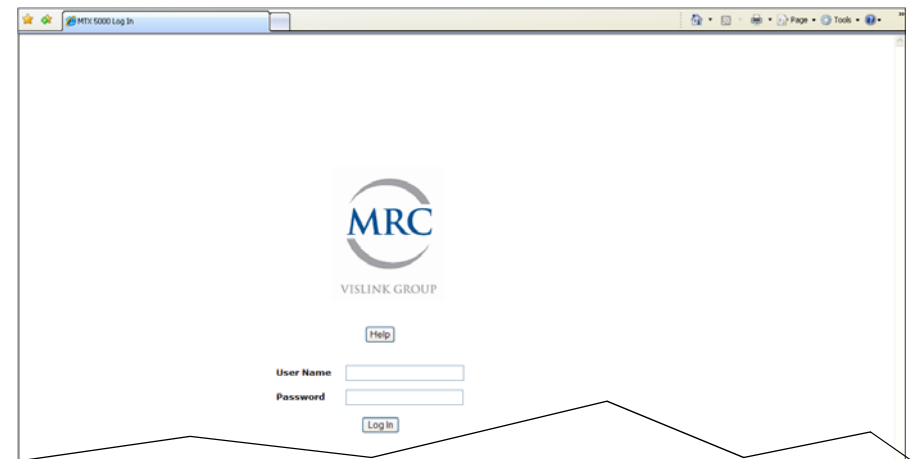
---

**Note** In the following step, **XXX.XXX.X.XX** is the IP address of your MTX5000 IDU.

---

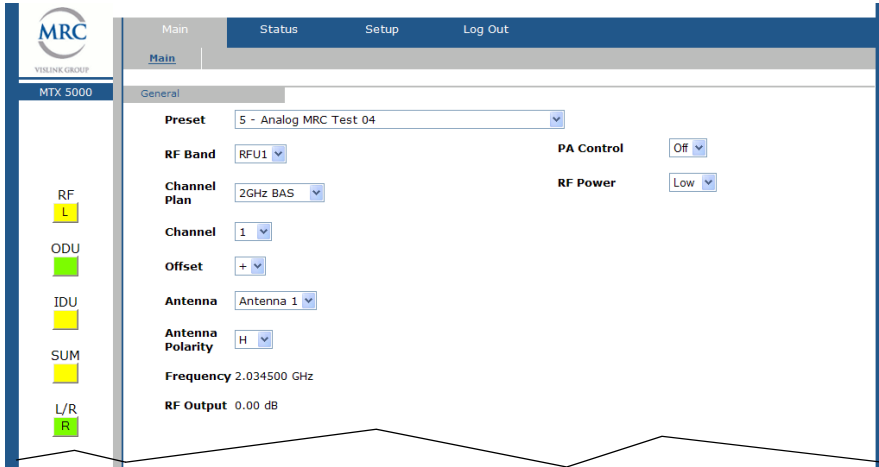
11. At the remote PC, open your web browser, enter the IP address for your MTX5000 IDU, and press the keyboard **Enter** key. The IP address should be entered as follows:  
  
**http://XXX.XXX.X.XX/nfs/main/html**
12. After a short delay, observe the remote log in screen is displayed. See Figure 5-202.

**Figure 5-202: Remote Log In Screen - Typical**



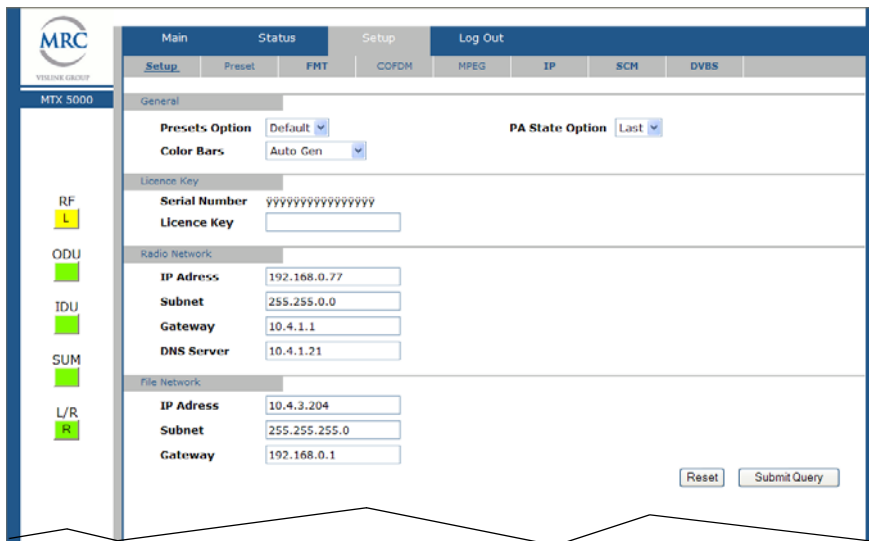
13. Enter your administrator user name in the **User Name** text box, enter your administrator password in the **Password** text box, select the **Log In** option button, and observe the **MTX5000 Main Page** is displayed. See Figure 5-203 on page 5-98.

**Figure 5-203: MTX5000 Main Page - Typical**



14. Select the **Setup** tab and observe the **Setup** page is displayed by default. See Figure 5-204.

**Figure 5-204: Setup Tab - Typical**



**Note** In the following step, if a factory default digital IP Preset is to be used to prepare a new Preset configuration, select the **Default** option.

If a custom digital IP Preset is to be updated or is to be used to prepare a new Preset, select the **User** option.

15. Use the **Presets Option** pull-down menu and select **Default** or **User**, as required.
16. Use the **Color Bars** pull-down menu and select **Off**, **On**, **Auto Gen**, or **Auto Standby**, as required.
17. Use the **PA State Option** pull-down menu to select **Off** or **Last**, as required, and select the **Submit** option button.
18. Select the **Main** tab and observe the **Main** page is displayed.
19. Use the **Preset** pull-down menu to select the default or user custom digital IP Preset required.
20. Select the **Setup** tab and observe the **Setup** page is displayed.
21. Select the **COFDM** tab and observe the **COFDM** page is displayed.
22. Use the **Constellation** pull-down menu to select **QPSK**, **16-QAM**, or **64-QAM**, as required.
23. Use the **FEC** pull-down menu to select **1/2**, **2/3**, **3/4**, **5/6**, or **7/8**, as required.
24. Use the **Guard Interval** pull-down menu to select **1/32**, **1/16**, **1/8**, or **1/4**, as required.
25. Use the **RF B/W** pull-down menu to select **6 MHz**, **7 MHz**, **8 MHz**, **10 MHz**, or **20 MHz**, as required.



26. Select the **Submit** option button.
27. Select the **MPEG** tab and observe the **MPEG** page is displayed.
28. Use the **General - Spectrum Invert** pull-down menu to select **Normal** or **Inverted**, as required.
29. Use the **Video In - Input** pull-down menu to select the input required.
30. Use the **Video Input - Noise Reduction** pull-down menu to select **On** or **Off**, as required.
31. Use the **Video Input - SDI Autoline** pull-down menu to select **On** or **Off**, as required.
32. Use the **Video Input - HD Test Pattern** pull-down menu to select **On** or **Off**, as required.
33. Use the **Audio 1 - Mode** pull-down menu to select **Dual Mono** or **Stereo**, as required.
34. Use the **Audio 1 - Input** pull-down menu to select **Test Tone, Analog, SDI Emb, AES-EBU** or **Channel Ident**, as required.
35. Use the **Audio 1 - Standard** pull-down menu to select **Off, MPEG Layer II, Linear PCM, or MPEG Layer I**, as required.
36. Use the **Audio 1 - Bit Rate** pull-down menu to select the bit rate required.
37. Use the **Audio 2 - Mode** pull-down menu to select **Dual Mono** or **Stereo**, as required.
38. Use the **Audio 2 - Input** pull-down menu to select **Test Tone, Analog, SDI Emb, AES-EBU** or **Channel Ident**, as required.
39. Use the **Audio 2 - Standard** pull-down menu to select **Off, MPEG Layer II, Linear PCM, or MPEG Layer I**, as required.
40. Use the **Audio 2 - Bit Rate** pull-down menu to select the bit rate required.
41. Use the **Audio 2 - Balance** pull-down menu to select **Unbalanced** or **Balanced**, as required.
42. Use the **Encoder - Mode** pull-down menu to select **Standard** or **Low Delay**, as required.
43. Use the **Encoder - Bit Rate** text box to enter the bit rate required.
44. Use the **Encoder - Bit Rate Auto** pull-down menu to select **On** or **Off**, as required.
45. Use the **Encoder - PTS per Picture** pull-down menu to select **On** or **Off**, as required.
46. Use the **Encoder - Horiz Resolution** pull-down menu to select **720, 704, 544, 480** or **352**, as required.
47. Use the **Encoder - Profile** pull-down menu to select **MP@HL** or **422P@HL**, as required.

---

**Note** In the following step, if the **Bit Rate Auto** pull-down menu option selected was **On**, the **ASI Bit Rate** text box is inactive and cannot be changed. Go to [step 49](#).

If the **Bit Rate Auto** pull-down menu option selected was **Off**, the **ASI Bit Rate** text box is active and the bit rate can be changed.

---

48. Select the **Encoder - ASI Bit Rate** text box and enter the bit rate required.

---

**Note** In the following step, if the **Remux** pull-down menu **On** option is selected, the **Bit Rate Auto** pull-down menu will become inactive, the **ASI Bit Rate** text box becomes active, and the bit rate can be changed.

---

49. Use the **Encoder - Remux** pull-down menu to select **On** or **Off**, as required.
50. Select the **Encoder - GOP Length** text box and enter the group of pictures length required.
51. Use the **Encoder - Aspect ratio** pull-down menu to select **16:9** or **4:3**, as required.
52. Use the **Encoder - VBI** pull-down menu to select **On** or **Off**, as required.
53. Select the **PID - Video** text box and enter the program identifier, as required.
54. Select the **PID - PCR** text box and enter the program identifier, as required.
55. Select the **PID - PMT** text box and enter the program identifier, as required.
56. Select the **PID - Audio 2** text box and enter the program identifier, as required.
57. Select the **PID - Data** text box and enter the program identifier, as required.
58. Select the **PID - Audio 1** text box and enter the program identifier, as required.
59. Select the **Encoding - Service Name** text box and enter the service name, as required.
60. Select the **Encoding - Network Name** text box and enter the network name, as required.

61. Use the **Encoding - Data Enable** pull-down menu to select **Off**, **TTV Format**, **CJM2 Format**, or **Low Delay CJM2**, as required.
62. Use the **Encoding - Baud Rate** pull-down menu to select **1200**, **2400**, **4800**, **9600**, **19200**, or **38400**, as required.
63. Select the **Submit** option button.
64. Select the **IP** tab and observe the **IP** page is displayed.
65. Use the **IP Transfer Mode** pull-down menu to select **IP Only** or **IP + Video**, as required.

---

**Note** In the following step, the **Video Bit Rate** text box is active only if the **IP Transfer Mode** menu **IP + Video** option was selected.

---

66. Select the **Video Bit Rate** text box and enter the bit rate required.
67. Select the **Symbol Rate** text box and enter the symbol rate required.
68. Select the **Preset** tab and observe the **Preset** page is displayed.

---

**Notes** In the following steps, if a factory default digital IP Preset was used as a “make-from” to prepare this custom Preset, the **Preset Text** text box and the **Preset Number** text box *must be* changed. **You cannot change or overwrite any factory default Presets!**

If a custom digital IP Preset was used as a “make-from” to prepare this custom Preset, a brief description of the custom Preset should be entered in the **Preset Text** text box for easy identification purposes. The Preset number must be changed only if you do not wish to overwrite the custom Preset.

- 
69. Select the **Preset Text** text box and enter a unique digital IP Preset description.

---

**Note** If you used a factory **Default** Preset or a custom **User** Preset as a “make-from” and you want to add the new Preset to the list of **User** Presets contained in your MTX5000 IDU, you must know the highest user Preset number contained in your IDU. To add the new Preset to the list of **User** Presets, go to [step 70](#).

If you used a custom **User** Preset as a “make-from” and you want to use it to replace (overwrite) an existing custom **User** Preset, go to [step 72](#).

- 
70. Select the **Preset Number** text box and enter any Preset number that is higher than the current highest Preset in your MTX5000 IDU.

71. Select the **Submit** option button and observe that the **Preset Number** automatically displays the next higher Preset number available in the Preset **User** list. Go to [step 73](#).
72. Select the **Preset Number** text box, enter the Preset number that you wish to overwrite, and select the **Submit** option button.
73. Observe the new Preset configuration has been loaded into the MTX5000 IDU and the new Preset name and Preset number are displayed on the Main page.

## 5.6 Preset File Management

---

### **CAUTION**

***Avoid damage to the color LCD display panel when performing the following procedures!***

*The color LCD display panel touch screen may be damaged if a sharp, hard-pointed object, such as a pencil or a pen, is used to select the displayed options.*

*Touch screen options must only be selected using your fingers, a soft-pointed stylus, or the front panel function keys.*

***Damage to the color LCD display panel caused by using a hard-pointed object or other misuse may void your warranty on the MTX5000 IDU.***

---

---

**Note** Procedures contained in this section may only be performed in the Local mode.

---

The procedures required to save Preset configuration files contained on your MTX5000 IDU to a USB flash drive, also referred to as a thumb drive, memory stick, or memory device, and to load Preset configuration files into your MTX5000 IDU are contained in the following paragraphs. The procedures contained in these paragraphs can only be performed in the Local mode.

### 5.6.1 Restore Presets to Defaults

The procedure required to restore all custom Presets to the factory default Presets is contained in the following steps.

Prior to performing this procedure, it is highly recommended that you make a copy of any custom Preset files by performing [“Save Preset Configurations to a File”](#) on page 5-104.

When performing the following steps, all custom Presets will be deleted and only the factory default Presets will remain. In addition, the password and IP address will also be changed to the factory defaults.

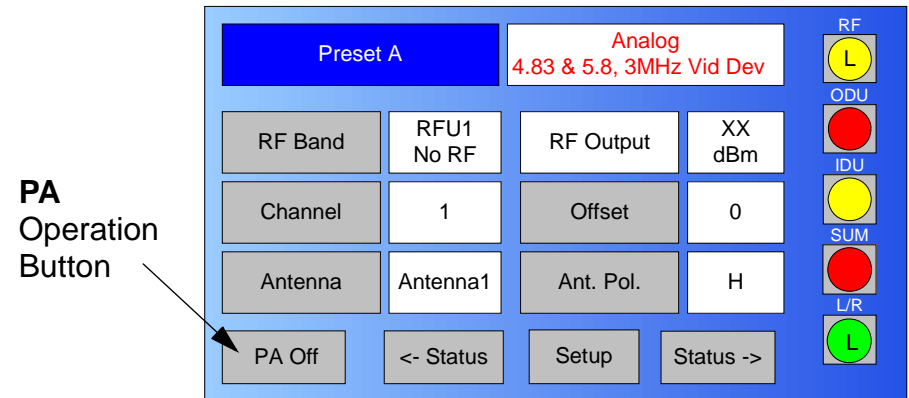
---

**Note** In the following steps, the color LCD display option buttons and pull-down menu options may be selected using either the touch screen or the function keys and the **SEL** key.

---

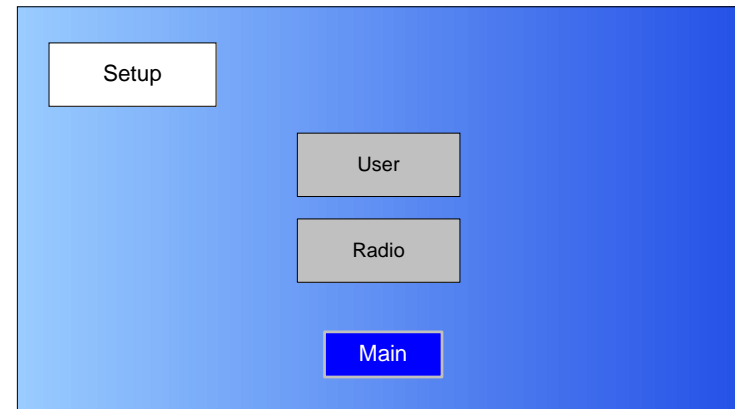
1. Verify the MTX5000 IDU is powered up. See [“Powering the MTX5000 System”](#) on page 3-7.
2. Observe the Main screen is displayed. See [Figure 5-205](#).

**Figure 5-205: Main Screen - Typical**



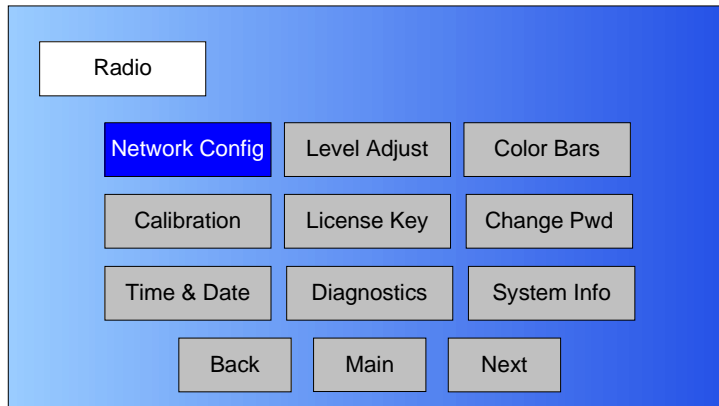
3. Select the Main screen **PA** operation button for **PA Off**, as required.
4. Select the **L/R** option button for **L** (local mode), as required.
5. Select the **Setup** option button and observe the **Setup** screen is displayed. See [Figure 5-206](#).

**Figure 5-206: Setup Screen**



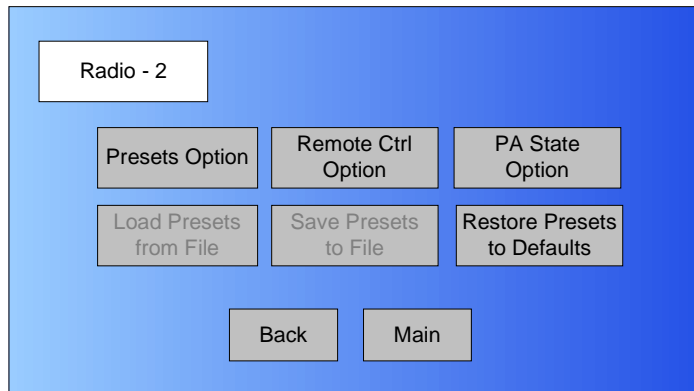
- Select the **Radio** option button and observe the **Radio** screen is displayed. See [Figure 5-207](#).

**Figure 5-207: Radio Screen**



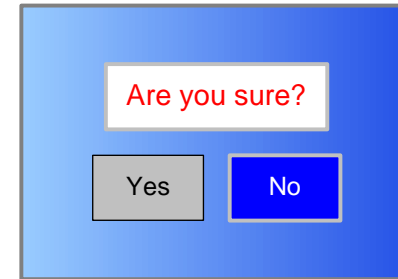
- Select the **Next** option button and observe the **Radio - 2** screen is displayed. See [Figure 5-208](#).

**Figure 5-208: Radio - 2 Screen**



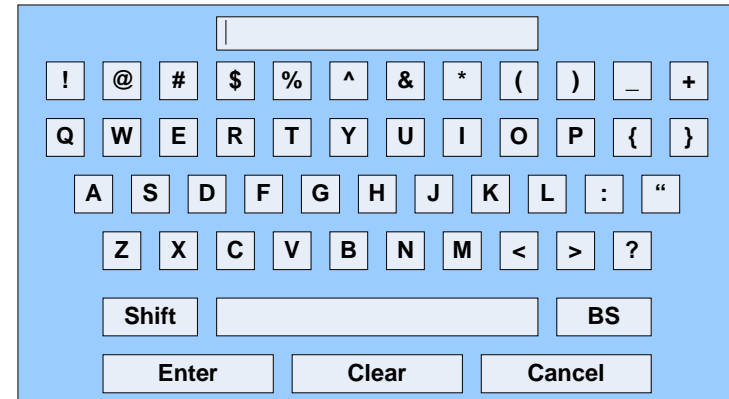
- Select the **Restore Presets to Defaults** option button and observe the **Are you sure?** screen is displayed. See [Figure 5-209](#).

**Figure 5-209: Are you sure? Screen**



- Select the **Yes** option button and observe the keyboard screen is displayed. See [Figure 5-210](#).

**Figure 5-210: Keyboard Screen**




---

**Note** When the **Enter** key is selected in the following step, the MTX5000 IDU will perform an automatic re-boot.

It will take approximately two minutes for the re-boot to be complete.

---

10. Enter your password, select the **Enter** key, observe **Please Wait** is briefly displayed, the **Operation Mode** screen is briefly displayed, and observe the MTX5000 IDU automatically re-boots.
11. Observe the Main page is displayed and the Preset description text box indicates **Default Presets**. Perform “[Select Preset](#)” on page 3-24 to select a Preset, as required.
12. Perform “[Local Mode Password Control](#)” on page 5-3.
13. Perform “[Set Network Addresses for Remote Operation](#)” on page 5-109.

### 5.6.2 Save Preset Configurations to a File

The procedure required to save the current Preset configuration settings contained in your MTX5000 IDU to a USB memory device is contained in the following steps. Saving the Preset configuration settings to a USB memory device provides you with a backup of all custom Presets that have been prepared and saved in your MTX5000 IDU.

After the Preset configuration settings are saved to a USB memory device, the USB memory device may be used to load the same Preset settings into another MTX5000 IDU.

If the Preset settings are to be loaded into another MTX5000 IDU, the IDU must contain the same hardware configuration options and must have the same licensed options as the IDU from which the Preset configuration settings were saved to the USB memory device.

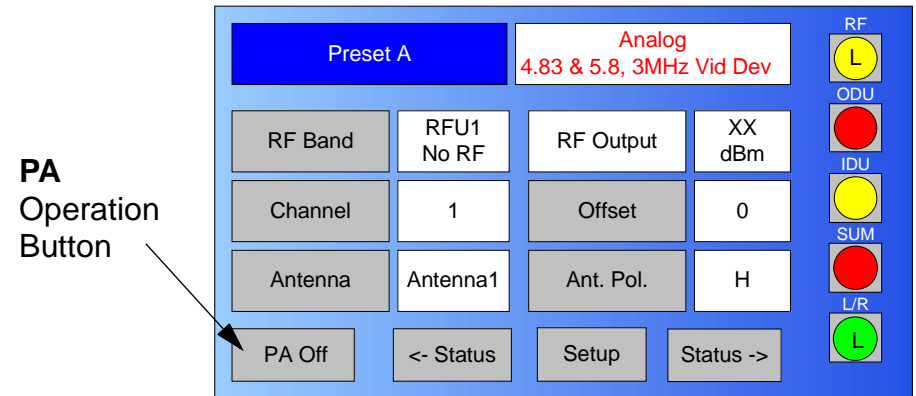
---

**Note** In the following steps, the color LCD display option buttons may be selected using either the touch screen or the function keys and the **SEL** key.

---

1. Verify the MTX5000 IDU is powered up. See “[Powering the MTX5000 System](#)” on page 3-7.
2. Observe the Main screen is displayed. See [Figure 5-211](#).

**Figure 5-211: Main Screen - Typical**

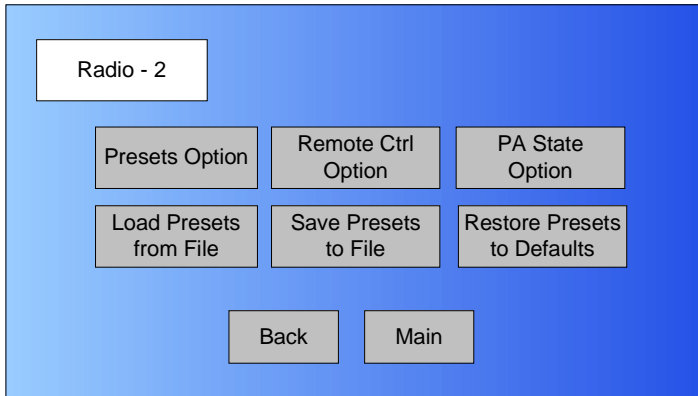


3. Select the Main screen **PA** operation button for **PA Off**, as required.
4. Select the **L/R** option button for **L** (local mode), as required.
5. Select the **Setup** option button and observe the **Setup** screen is displayed. See [Figure 5-212](#) on page 5-105.



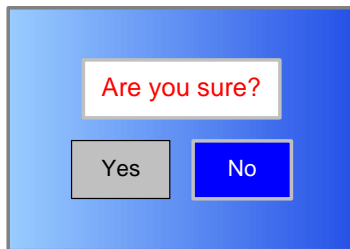
9. After a short delay, observe the **Save Presets to File** option button is active (not greyed-out). See [Figure 5-216](#).

**Figure 5-216: Preset File Screen - Typical**



10. Select the **Save Presets to File** option button and observe the **Are you sure?** screen appears. See [Figure 5-217](#).

**Figure 5-217: Are you sure? Screen**



11. Select the **Yes** option button and observe **Are you sure?** changes to read **Please wait**.
12. After a short delay, observe the **Please Wait!** text box disappears.

13. Disconnect the USB memory device and USB-A to USB-B adapter from the IDU front panel USB 2.0 connector.
14. Select the **Main** option button and observe the Main screen is displayed.

### 5.6.3 Load Preset Configurations from a File

The procedure required to load custom Preset configuration settings from a USB memory device into your MTX5000 IDU is contained in the following steps. This procedure may be used to load custom Preset configuration settings from one MTX5000 IDU into another MTX5000 IDU using the USB memory device to clone the IDU custom Preset configuration settings.

If the custom Preset settings are to be loaded into another MTX5000 IDU, the IDU must contain the same hardware configuration options and must have the same licensed options as the IDU from which the custom Preset configuration settings were saved to the USB memory device.

This procedure may also be used to recover custom Preset configuration settings in the event you suspect that your MTX5000 IDU internal software may have been corrupted during normal operation.

---

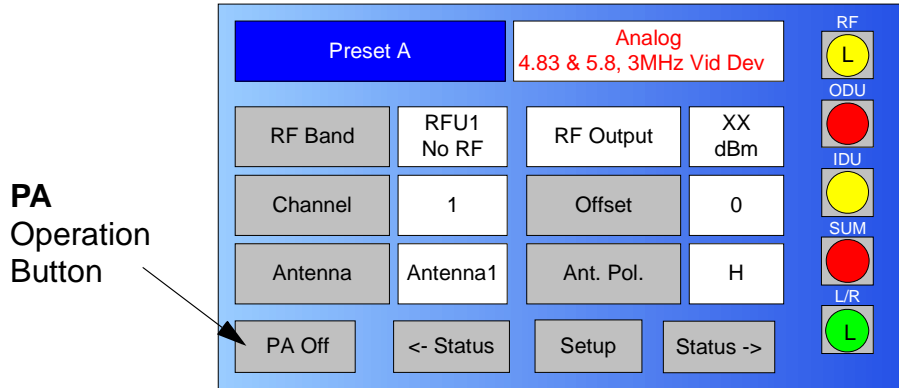
**Note** In the following steps, the color LCD display option buttons may be selected using either the touch screen or the function keys and the **SEL** key.

---

1. Verify the MTX5000 IDU is powered up. See ["Powering the MTX5000 System"](#) on page 3-7.
2. Observe the Main screen is displayed. See [Figure 5-218 on page 5-107](#).

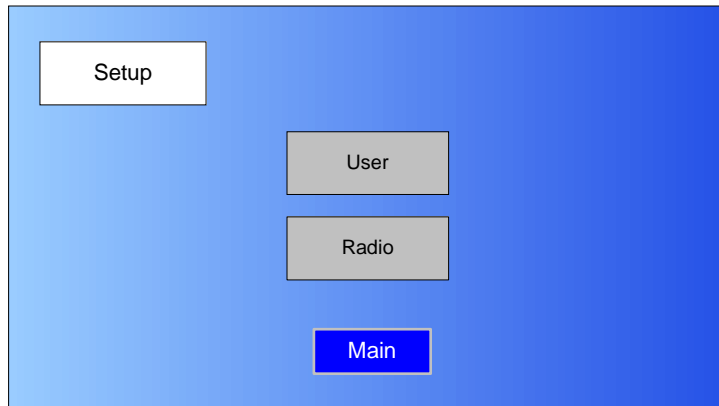


**Figure 5-218: Main Screen - Typical**



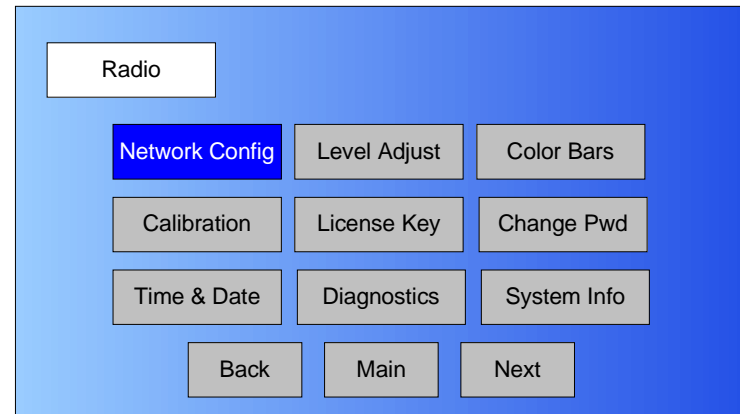
3. Select the Main screen **PA** operation button for **PA Off**, as required.
4. Select the **L/R** option button for **L** (local mode), as required.
5. Select the **Setup** option button and observe the **Setup** screen is displayed. See [Figure 5-219](#).

**Figure 5-219: Setup Screen**



6. Select the **Radio** option button and observe the **Radio** screen is displayed. See [Figure 5-220](#).

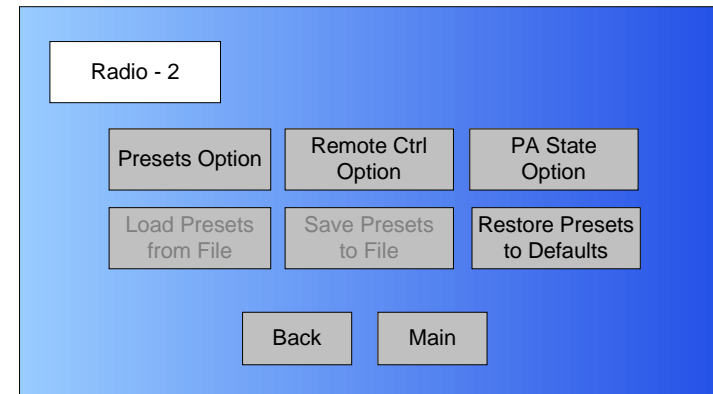
**Figure 5-220: Radio Screen**



**Note** In the following step, the **Load Presets from File** and **Save Presets to File** option buttons will be inactive (greyed-out) until a USB memory device is connected to the MTX5000 IDU front panel USB 2.0 connector.

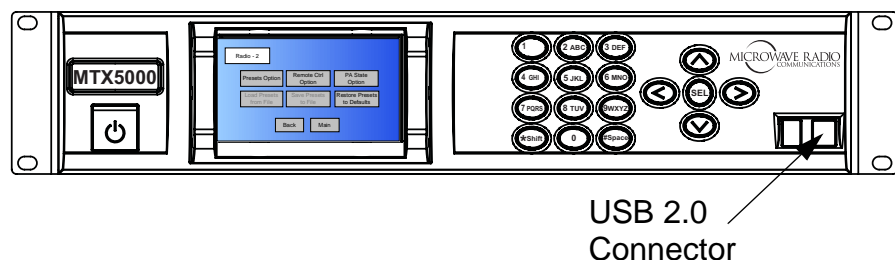
7. Select the **Next** option button and observe the **Radio - 2** screen is displayed. See [Figure 5-221](#).

**Figure 5-221: Radio - 2 Screen**

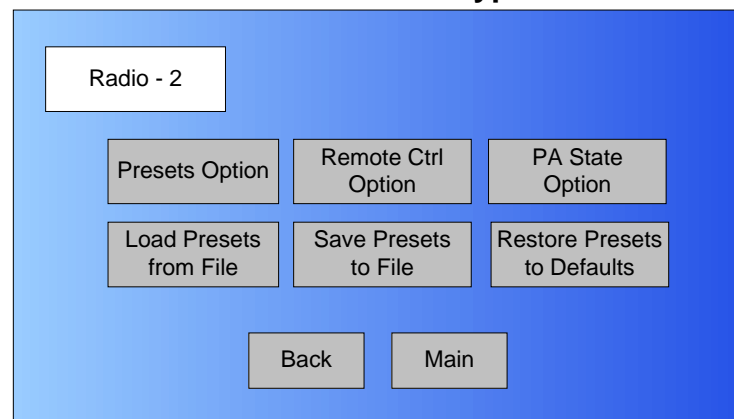


- Connect a USB memory device to a USB-A to USB-B adapter and connect the adapter to the IDU front panel USB 2.0 connector. See [Figure 5-222](#).

**Figure 5-222: IDU Front Panel USB Connector**

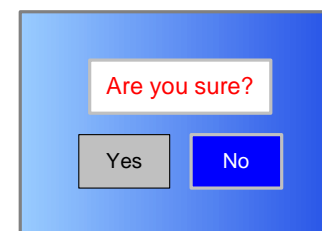


**Figure 5-223: Preset File Screen - Typical**



- Select the **Load Presets from File** option button and observe the **Are you sure?** screen is displayed. See [Figure 5-224](#).

**Figure 5-224: Verification Screen**



- Select the **Yes** option button and observe the **Please Wait!** message box is displayed. See [Figure 5-225 on page 5-109](#).

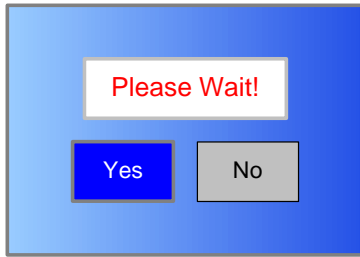
---

**Notes** Ensure your memory device contains the custom Preset setting configuration file required.

The **Load Presets from File** option button will not be active in the following step if there is no Preset setting configuration file currently contained on the USB memory device.

- After a short delay, observe the **Load Presets from File** option button is active (not greyed-out). See [Figure 5-223](#).

**Figure 5-225: Please Wait Message Box**



12. When the **Please Wait!** message box disappears, go to the following step.
13. Disconnect the USB memory device and USB-A to USB-B adapter from the IDU front panel USB 2.0 connector.
14. Select the **Main** option button and observe the Main screen is displayed.

## 5.7 Set Network Addresses for Remote Operation

The steps required to set the radio network, file network, and trap configuration addresses are contained in the following procedures. These procedures may only be performed in the Local mode of operation.

---

**CAUTION** *Avoid damage to the color LCD display panel!*

*The color LCD display panel touch screen may be damaged if a sharp, hard-pointed object, such as a pencil or a pen, is used to select the displayed options.*

*Touch screen options must only be selected using your fingers, a soft-pointed stylus, or the front panel function keys.*

*Damage to the color LCD display panel caused by using a hard-pointed object or other misuse may void your warranty on the MTX5000 IDU.*

---

The procedure required to set the network addresses to allow operation of your MTX5000 System from a remote location is contained in the following steps.

***Before proceeding with this procedure, you must obtain valid Radio IP, Subnet Mask, Gateway, and DNS Server addresses from your Network Administrator.*** All addresses must be properly entered into your MTX5000 IDU before you can operate your MTX5000 System from a remote location.

***It is important that the MTX5000 must not be transmitting when this procedure is performed.***

When updating the software in the IDU, you must observe the following **CAUTIONS** to avoid corrupting software.

---

**CAUTION** *Do not power down the MTX5000 system when the software update progress bar is displayed, as the software update can become corrupted.*

---

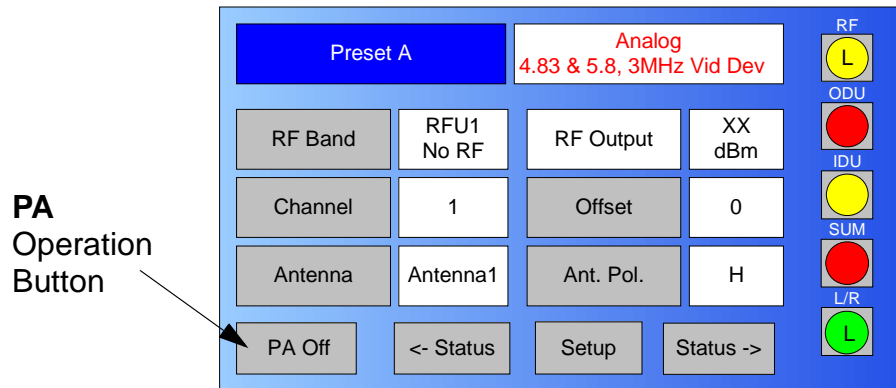
**CAUTION** Do not attempt to perform this procedure while the MTX5000 system is actively transmitting.

Attempts to perform this procedure when the system is transmitting will interrupt broadcast operations.

**Note** In the following steps, option buttons may be selected using either the touch screen or the function keys and the **SEL** key.

1. Verify the MTX5000 IDU is powered up. See "Powering the MTX5000 System" on page 3-7.
2. Observe the Main screen is displayed. See Figure 5-226.

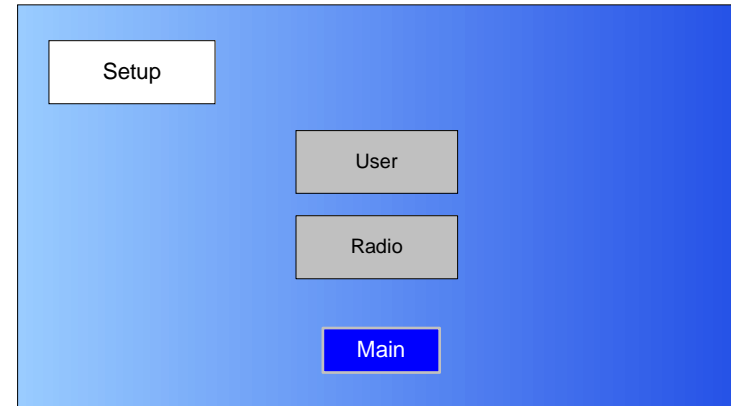
**Figure 5-226: Main Screen - Typical**



3. Select the Main screen **PA** operation button for **PA Off**, as required.

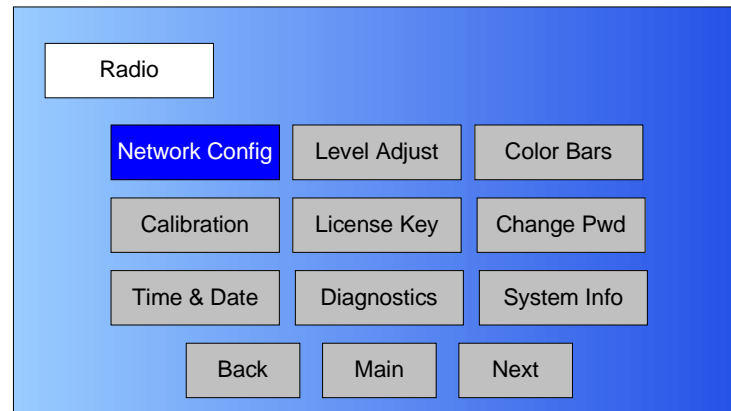
4. Select the **L/R** option button for **L** (local mode), as required.
5. Select the **Setup** option button and observe the **Setup** screen is displayed. See Figure 5-227.

**Figure 5-227: Setup Screen**



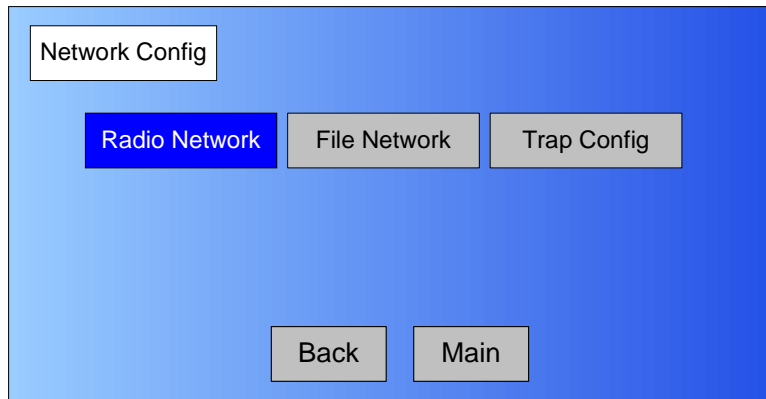
6. Select the **Radio** option button and observe the **Radio** screen is displayed. See Figure 5-228.

**Figure 5-228: Radio Screen**



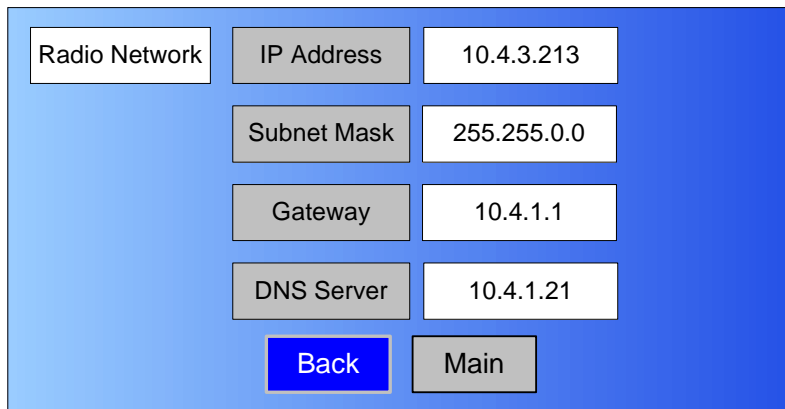
7. Select the **Network Config** option button and observe the **Network** screen is displayed. See [Figure 5-229](#).

**Figure 5-229: Network Config Screen**



8. Select the **Radio Network** option button and observe the **Radio Network** screen is displayed. See [Figure 5-230](#).

**Figure 5-230: Radio Network Screen - Typical**



---

**CAUTION**

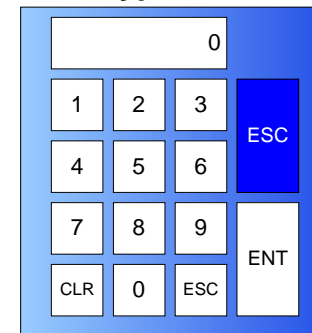
In the following steps, the **IP Address**, **Subnet Mask**, **Gateway**, and **DNS Server** addresses must all be entered correctly.

If the addresses don't match the configuration of the network to which the MTX5000 IDU is connected, the MTX5000 IDU will not be detected and cannot be used from a remote location.

---

9. Select the **IP Address** option button and observe the numeric keypad is displayed. See [Figure 5-231](#).

**Figure 5-231: Numeric Keypad**



10. Enter the IP address, select the **ENT** key, and observe the **Radio Network** screen is displayed.
11. Select the **Subnet Mask** option button and observe the numeric keypad is displayed.
12. Enter the Subnet Mask address, select the **ENT** key, and observe the **Radio Network** screen is displayed.
13. Select the **Gateway** option button and observe the numeric keypad is displayed.

14. Enter the Gateway address, select the **ENT** key, and observe the **Radio Network** screen is displayed.
15. Select the **DNS Server** option button and observe the numeric keypad is displayed.
16. Enter the DNS Server address, select the **ENT** key, and observe the **Radio Network** screen is displayed.
17. Select the **Back** option button and observe the **Network Config** screen is displayed.

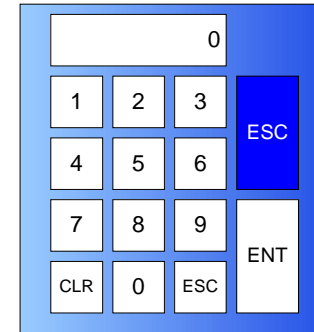
---

**Note** When entering **File Network** addresses in the following steps, the addresses cannot be the same as the **Radio Network** addresses.

---

19. Select the **IP Address** option button and observe the numeric keypad is displayed. [See Figure 5-233.](#)

**Figure 5-233: Numeric Keypad**



20. Enter the IP address, select the **ENT** key, and observe the **File Network** screen is displayed.
21. Select the **Subnet Mask** option button and observe the numeric keypad is displayed.
22. Enter the Subnet Mask address, select the **ENT** key, and observe the **File Network** screen is displayed.
23. Select the **Gateway** option button and observe the numeric keypad is displayed.
24. Enter the Gateway address, select the **ENT** key, and observe the **File Network** screen is displayed.
25. Select the **Back** option button and observe the **Network Config** screen is displayed.
26. Select the **Trap Config** option button and observe the Trap Config screen is displayed. [See Figure 5-234 on page 5-113.](#)

---

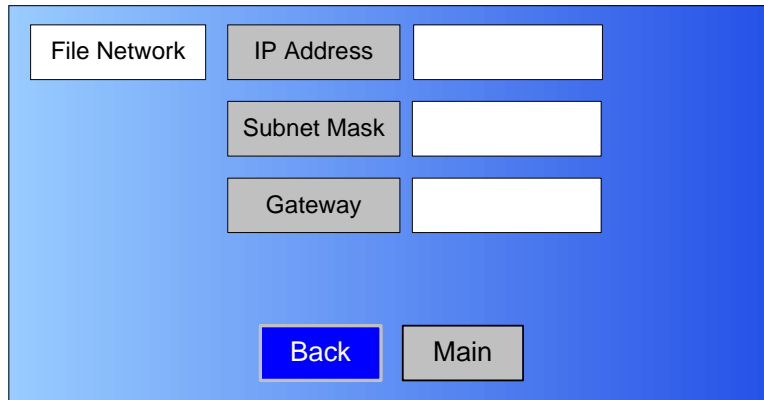
**Note** If you do not have the IP option installed, the **File Network** option button will be inactive (greyed-out) in the following step.

If the **File Network** option button is inactive, go to [step 25](#).

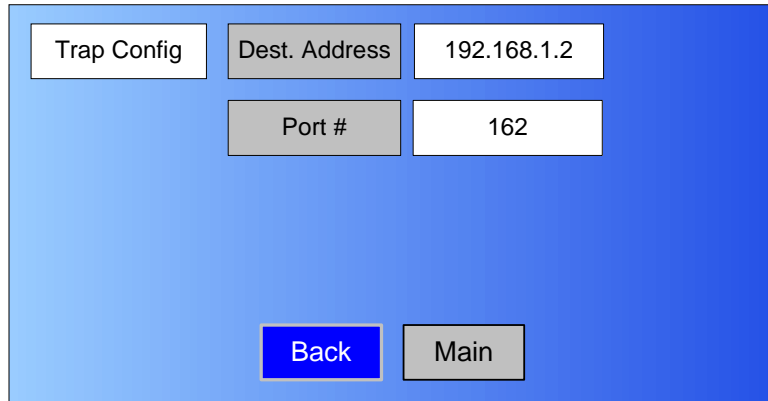
---

18. Select the **File Network** option button and observe the **File Network** screen is displayed. [See Figure 5-232.](#)

**Figure 5-232: File Network Screen - Typical**



**Figure 5-234: Trap Config Screen - Typical**



27. Select the **Dest. Address** option button and observe the numeric keypad is displayed.
28. Enter the destination address, select the **ENT** key, and observe the **Trap Config** screen is displayed.
29. Select the **Port #** option button and observe the numeric keypad is displayed.
30. Enter the port number required, select the **ENT** key, and observe the **Trap Config** screen is displayed.
31. Select the **Main** option button and observe the Main screen is displayed.
32. Press the front panel power switch to off, wait a minimum of 10 seconds, and press the power switch to on. When the Main screen is displayed, go to the following step.

---

**Notes** The following steps verify the correct **IP Address, Subnet Mask, Gateway, and DNS Server** addresses have been correctly entered by verifying that you can connect to your MTX5000 System from a remote PC.

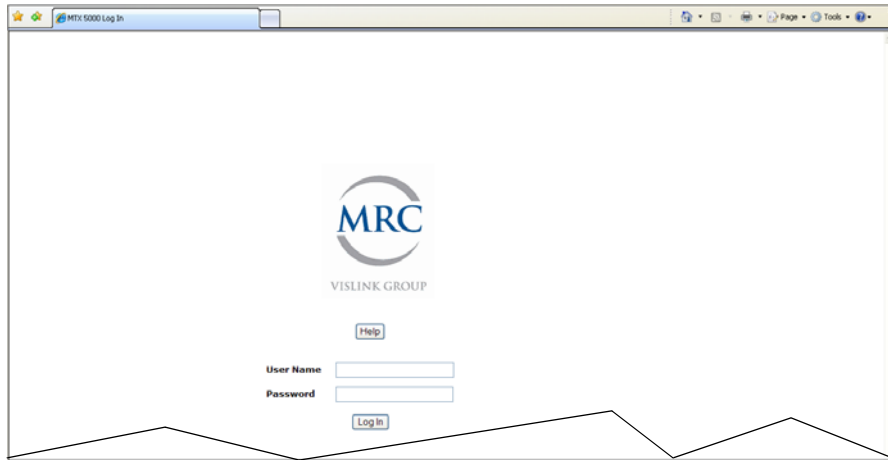
If the addresses have not been correctly entered, you will not be able to connect from a remote PC. Repeat from [step 5](#) to verify or correct addresses.

If all addresses have been correctly entered and you cannot connect from a remote PC, contact your Network Administrator for assistance.

---

33. Verify your MTX5000 IDU **ETHERNET** connector is properly connected to your network.
34. At the remote PC, open your web browser, enter the IP address for your MTX5000 IDU, and press the PC keyboard Enter key.
35. After a short delay, observe the remote screen display appears on your PC. [See Figure 5-235 on page 5-114.](#)

**Figure 5-235: Remote Screen Display - Typical**



36. Perform [“Select Local/Remote Operation Mode” on page 3-20](#) and set the MTX5000 for remote mode operation.
37. Verify operations can be performed from a remote PC by performing any selected procedure contained in [“Remote Location Operations” on page 3-67](#).
38. When remote operations are verified, select the MTX5000 IDU Main screen **L/R** option button to change it to **L** (local mode), as required.

## 5.8 Firmware Update

**CAUTION** *Avoid damage to the color LCD display panel when performing the following procedures!*

*The color LCD display panel touch screen may be damaged if a sharp, hard-pointed*

*object, such as a pencil or a pen, is used to select the displayed options.*

*Touch screen options must only be selected using your fingers, a soft-pointed stylus, or the front panel function keys.*

***Damage to the color LCD display panel caused by using a hard-pointed object or other misuse may void your warranty on the MTX5000 IDU.***

The procedure required to update firmware in your MTX5000 Indoor Unit (IDU) is contained in the following steps. Firmware updates must be obtained from the factory. The updates will be installed in the MTX5000 Indoor Unit (IDU) using a USB flash drive. The USB flash drive, also referred to as a thumb drive, memory stick, or memory device is connected to the MTX5000 IDU front panel USB 2.0 connector using a USB-A to USB-B adapter.

The firmware update procedure can be performed with the MTX5000 IDU disconnected from the system or can be performed when the IDU is installed in its normal rack-mounted position.

***It is important that the MTX5000 must not be transmitting when this procedure is performed.***

When updating the firmware in the IDU, you must observe the following **CAUTIONS** to avoid corrupting firmware.



**CAUTION** Do not power down the MTX5000 system when the firmware update progress bar is displayed, as the firmware update can become corrupted.

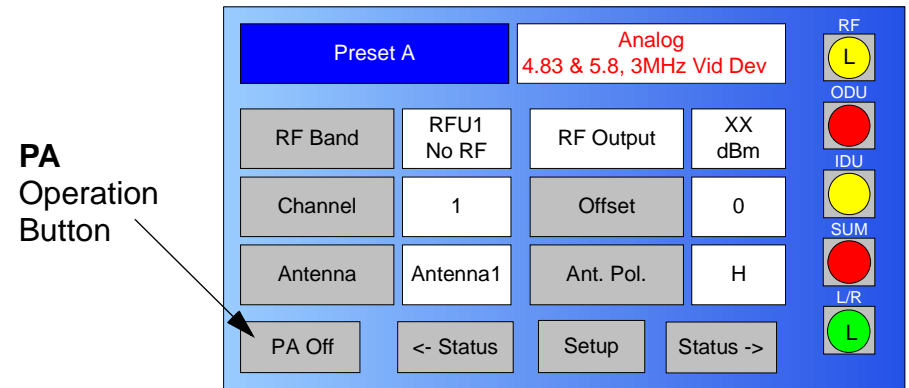
**CAUTION** Do not attempt to perform the IDU firmware update while the MTX5000 system is actively transmitting.

Attempts to program firmware updates into the IDU when the system is transmitting will interrupt broadcast operations.

**Note** In the following steps, option buttons may be selected using either the touch screen or the function keys and the **SEL** key.

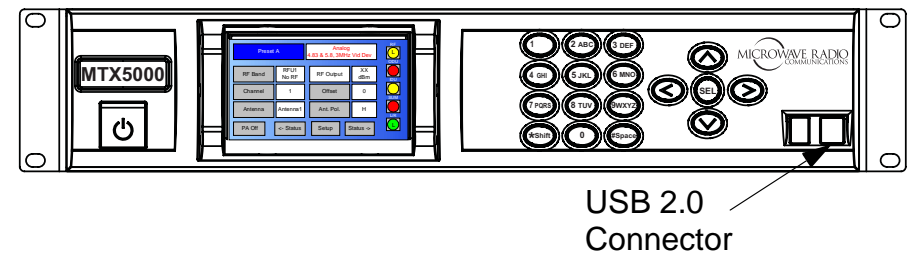
1. Verify the MTX5000 system is powered up per “Powering the MTX5000 System” on page 3-7.
2. Observe the Main screen is displayed. See Figure 5-236.

**Figure 5-236: Main Screen - Typical**



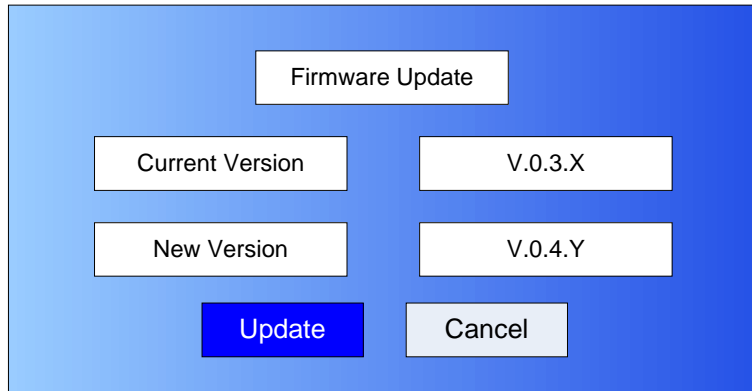
3. Select the Main screen **PA** operation button for **PA Off**, as required.
4. Select the **L/R** option button for **L** (local mode), as required.
5. Connect the USB memory device containing the software update to a USB-A to USB-B adapter and connect the adapter to the IDU front panel USB 2.0 connector. See Figure 5-237.

**Figure 5-237: IDU Front Panel USB Connector**



6. After a short delay, observe the **Firmware Update** screen is displayed. See Figure 5-238 on page 5-116.

**Figure 5-238: Firmware Update Screen - Typical**



**CAUTION** When the **Update** option button is selected in the following step, a progress bar will be displayed during the update process.

*Do not power the MTX5000 down for any reason while the progress bar is displayed, as the firmware upgrade will be corrupted.*

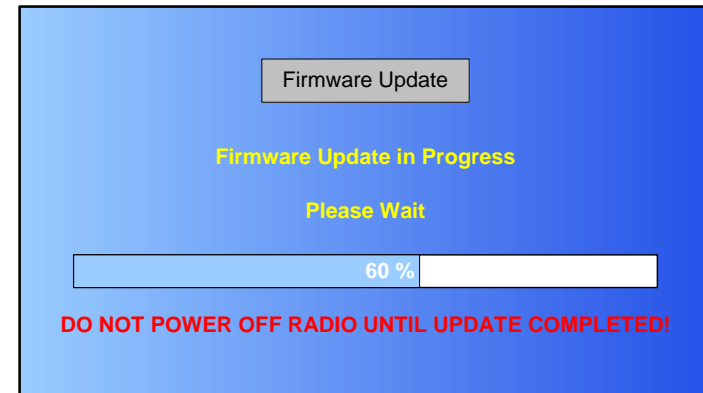
**CAUTION** To avoid corruption of the firmware update, do not remove the USB flash drive until the firmware update process is complete.

**Notes** If the **Current Version** and **New Version** are different, go to [step 7](#).

If the **Current Version** and **New Version** are identical, go to [step 10](#).

7. Select the **Update** option button and observe the **Firmware Update** screen is displayed and a progress bar is displayed during the update process. See [Figure 5-239](#).

**Figure 5-239: Firmware Update Screen - Typical**

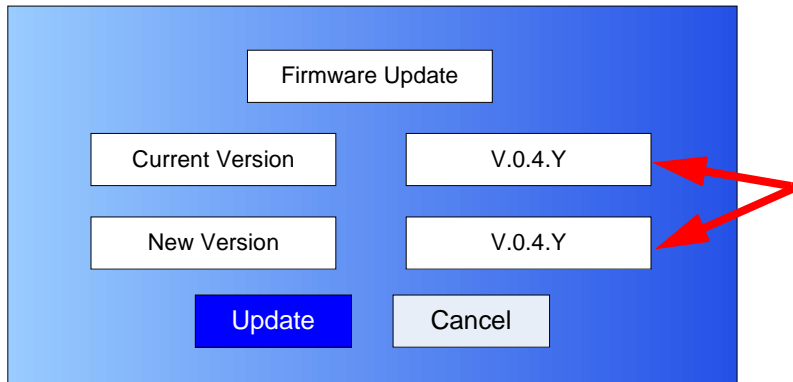


8. When the firmware update is complete, the IDU will re-boot, the Main screen will be displayed, and the **Firmware Update** screen will be displayed after a short delay.

**Note** In the following step, if the versions shown in the **Firmware Update** screen **Current Version** and the **New Version** text boxes are identical, the firmware update was successful.

9. Observe the **Current Version** and **New Version** text boxes indicate the same version. See [Figure 5-240 on page 5-117](#).

**Figure 5-240: Firmware Update Screen - Typical**



10. Disconnect the USB memory device and adapter from the IDU front panel USB 2.0 connector.
11. Select the **Cancel** option button, and observe the Main screen is displayed after a short delay.
12. Press the power switch to off, wait 10 seconds minimum, and press the power switch to on.

## 5.9 License Manager

This section describes how to add factory licensed options to your MTX5000 IDU. Only licensed options applicable to the hardware options contained in your MTX5000 IDU can be installed in your radio.

Your MTX5000 IDU does not have to be returned to the factory to add licensed options applicable to your MTX5000 IDU configuration. The internal software contains a license manager feature that allows you to add licensed options to your IDU that were not initially ordered with your radio.

The license manager procedure can be performed with the MTX5000 IDU disconnected from the system or can be

performed when the IDU is installed in its normal rack-mounted position.

***It is important, however, that the MTX5000 must not be transmitting when these procedures are performed.***

When performing procedures contained in this section, you must observe the following **CAUTIONS** to avoid corrupting software.

---

### **CAUTION**

***Avoid damage to the color LCD display panel!***

*The color LCD display panel touch screen may be damaged if a sharp, hard-pointed object, such as a pencil or a pen, is used to select the displayed options.*

*Touch screen options must only be selected using your fingers, a soft-pointed stylus, or the front panel function keys.*

***Damage to the color LCD display panel caused by using a hard-pointed object or other misuse may void your warranty on the MTX5000 IDU.***

---

### **CAUTION**

*Do not power down the MTX5000 system when the software update progress bar is displayed, as the software update can become corrupted.*

---

## CAUTION

Do not attempt to perform this procedure while the MTX5000 system is actively transmitting.

Attempts to program license manager features into the IDU when the system is transmitting will interrupt broadcast operations and may corrupt the software.

**In order to add a licensed option to your MTX5000 IDU, you must obtain a license key applicable to the option required. This license key is available only from MRC. Your IDU must also contain the hardware applicable to the licensed option.**

When ordering a license key from MRC, you must provide MRC with both the serial number of your MTX5000 IDU and the serial number of the main circuit board in the IDU. The IDU serial number is located on the right-hand side of the chassis.

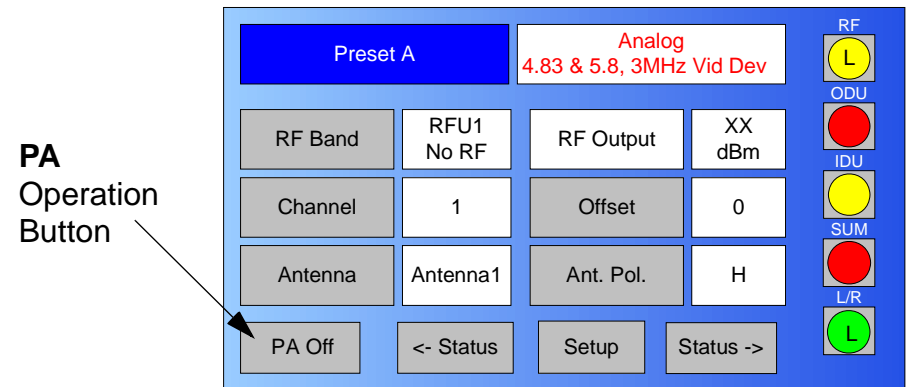
To identify the electronic serial number of the IDU Encoder/Modulator board, perform [step 1](#) thru [step 7](#) of the following procedure and record the serial number listed in the **Serial No.** text box.

The procedure required to install a new licensed option, after obtaining the license key from MRC, is contained in the following steps. This procedure is generic and can be used to install all licensed options in your MTX5000 IDU. Each licensed option contained in your MTX5000 IDU requires an individual license key.

**Note** In the following steps, the color LCD display option buttons may be selected using either the touch screen or the function keys and the **SEL** key.

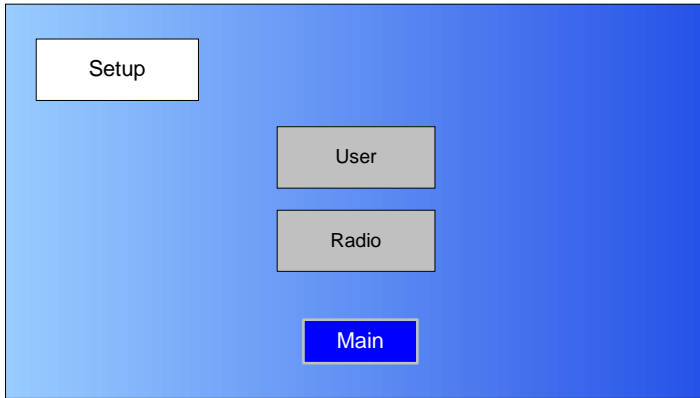
1. Verify the MTX5000 IDU is powered up. See ["Powering the MTX5000 System"](#) on page 3-7.
2. Observe the Main screen is displayed. See [Figure 5-241](#).

**Figure 5-241: Main Screen - Typical**



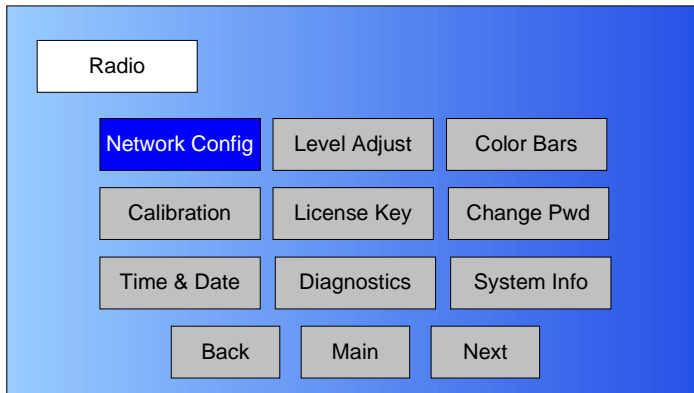
3. Select the Main screen **PA** operation button for **PA Off**, as required.
4. Select the **L/R** option button for **L** (local mode), as required.
5. Select the Main screen **Setup** option button and observe the **Setup** screen is displayed. See [Figure 5-242](#) on page 5-119.

**Figure 5-242: Setup Screen**



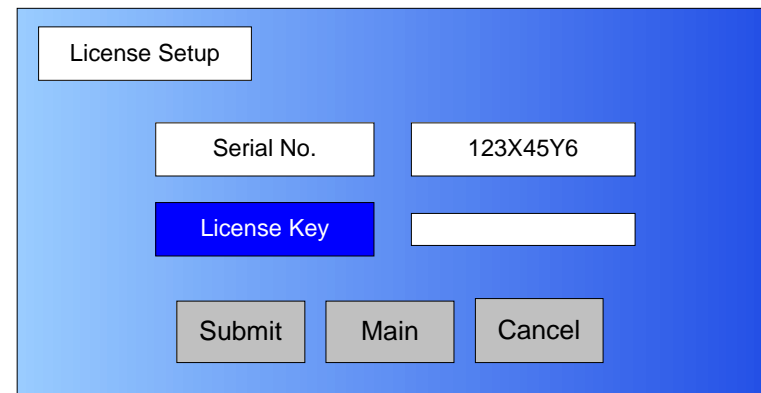
6. Select the **Radio** option button and observe the **Radio** screen is displayed. [See Figure 5-243](#)

**Figure 5-243: Radio Screen**



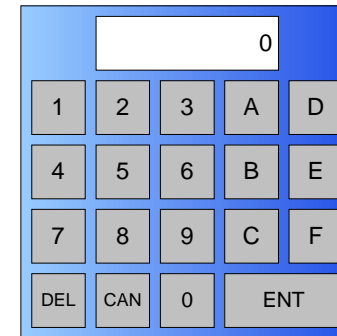
7. Select the **License Key** option button and observe the **License Setup** screen is displayed. [See Figure 5-244](#).

**Figure 5-244: License Setup Screen - Typical**



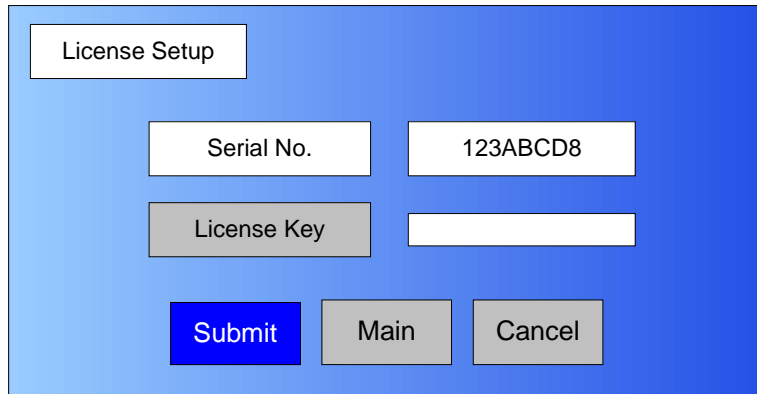
8. Select the **License Key** option button and observe the alphanumeric keyboard is displayed. [See Figure 5-245](#).

**Figure 5-245: Alphanumeric Keyboard**



9. Enter the 12-character license key obtained from MRC, select the **ENT** key, and observe the **License Setup** screen is displayed. [See Figure 5-246 on page 5-120](#).

**Figure 5-246: License Setup Screen - Typical**



The screenshot shows a 'License Setup' window with a blue background. At the top left, there is a white box containing the text 'License Setup'. Below this, there are two input fields. The first is labeled 'Serial No.' and contains the text '123ABCD8'. The second is labeled 'License Key' and is currently empty. At the bottom of the window, there are three buttons: a blue 'Submit' button, a gray 'Main' button, and a gray 'Cancel' button.

---

**Notes** When the **Submit** option button is selected in the following step, the licensed option will be enabled if the correct license key was entered.

If a typing error occurred when the license key was entered, no verification or error message will be displayed. Incorrect keys will be stored in the IDU memory.

If the licensed option does not perform as expected during normal operation, repeat from [step 7](#) to enter the correct license key.

- 
10. Select the **Submit** option button.
  11. Select the **Main** option button and observe the Main screen is displayed.

# 6 Installation

## 6.1 Chapter Overview

This chapter describes how to unpack and install your MTX5000 Transmitter System (MTX5000). The MTX5000 system consists of the MTX5000 Indoor Unit (IDU) and Outdoor Unit (ODU), also referred to as the RF Unit. The topics covered in this chapter are as follows:

Topic	Page
Unpacking	6-1
Initial Inspection	6-2
Damage in Shipment	6-2
Installing the MTX5000 IDU	6-2
Site Preparation	6-2
Mounting the MTX5000 IDU	6-3
Power Connections	6-4
Power Requirements	6-4
Power Supply and Distribution	6-4
Grounding	6-5
Defining the Wiring Harness	6-5
Steps to Define the Harness	6-5
Select the Type of RF/Power Cabling	6-5
Select the Function Cables Required	6-7
Determine the Size of Harness Required	6-9
Cabling Requirements	6-9
MTX5000 System Type “N” Connector Interface	6-11
MTX5000 System TNC Connector Interface	6-12

Installing the Fabricated Harness	6-13
Installing the Outdoor Unit	6-13
Site Preparation	6-14
Mounting the ODU	6-14
Making the Connections	6-15
Mast Top Connections	6-16
IDU Connections	6-16
Wayside Data Connections	6-24
Wayside Connections	6-24
Compatibility	6-24
Audio Connections	6-24
Audio Inputs	6-24
Analog Audio Inputs	6-25
Digital Audio Inputs	6-25
ODU Power	6-26
Remote Control Operations	6-26
Powering Up	6-27
Checks Before Power-Up	6-27
Initial Power-Up	6-27
Power Down	6-29
Product Modifications	6-29

## 6.2 Unpacking

Each MTX5000 is shipped assembled, wired, and factory tested. Each unit is packaged in appropriate shipping containers.

Here are some tips to help you with unpack your new equipment:

- Unpack the equipment carefully to avoid accidental damage.

- Be sure to locate all parts and accessories.
- Verify that the items shipped agree with those listed on the packing list.
- DO NOT discard the container(s) or packing material until you have inspected the equipment and are sure there is no shipping damage. The container(s) and packing must be available in the event that a damage claim needs to be filed with the shipping carrier.

## 6.3 Initial Inspection

After the equipment is unpacked, we recommend you inspect it using the following checklist:

- Check for any dents or scratches.
- Check that the equipment is clean and dry.
- Check that no cables or connectors are broken, damaged, or loose.
- Check that no switch, keypad, or function keys are broken, damaged, or loose.
- Check that the LCD display has not been damaged.

## 6.4 Damage in Shipment

Should any damage be discovered after unpacking the unit, use the following procedure:

- Immediately file a claim with the shipping carrier.
- Forward a copy of the damage report to MRC Customer Service.
- Contact MRC Customer Service to determine the disposition of the equipment.

## 6.5 Installing the MTX5000 IDU

For mobile applications, the MTX5000 is typically mounted in a bulkhead or compartment 19-inch (48.3 cm) rack and the cabling is permanently installed. Power comes from the mobile power source.

### 6.5.1 Site Preparation

The following requirements are designed to make initial installation easier and to allow room for future access and servicing.

**Equipment Rack** The MTX5000 mounts into the mounting rails of a standard 19-inch (48.3 cm) equipment rack. It occupies 2 rack units (2RU) of height.

- Make certain the rack and mounting rails are strong and rigid enough to support the MTX5000 and the rest of the equipment in the rack.
- It is recommended that a rack mount shelf be installed in the back of the rack to help support the MTX5000 during the high stresses of vehicle vibration.
- The rack should be securely attached to a solid surface such as a floor or wall to prevent movement or tipping over.
- Position the rack to allow easy access to the front and rear of the equipment.
- Be sure to allow room behind the equipment rack for the many cables required. The cables should not be pressed against the rear of the equipment when closing doors. This will stress the cables and may shorten their life.



## 6.5.2 Mounting the MTX5000 IDU

Mounting the MTX5000 IDU into an equipment rack is easier if one person holds the unit while another person installs the mounting screws.

---

**WARNING** Follow instructions carefully.

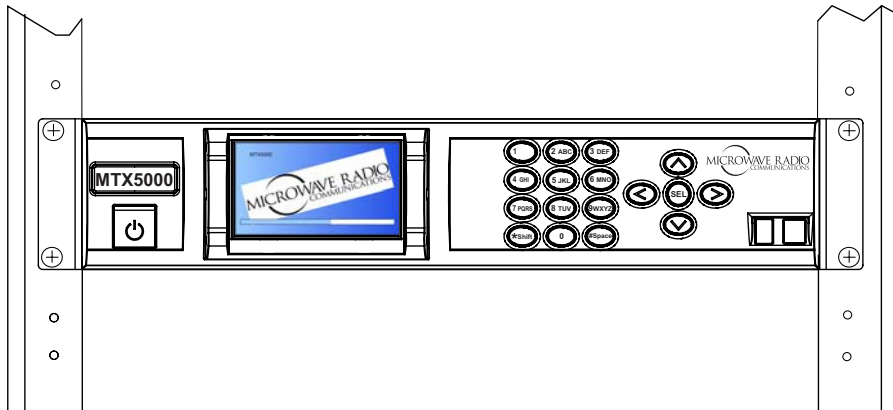


*Exercise care to avoid equipment damage or personnel injury.*

---

1. Lift the MTX5000 IDU into place, lining up its mounting holes with the holes in the rack mounting rails. See [Figure 6-1](#).

**Figure 6-1: MTX5000 IDU Mounting**



2. Install the two bottom screws first. Use lock washers to prevent loosening. Tighten securely.
3. Install the top two screws. Use lock washers to prevent loosening. Tighten securely.

### Ventilation

---

**CAUTION** *Temperatures inside a closed mounting area can be significantly higher than the ambient temperature. Always allow adequate ventilation.*

---

- If possible, install the MTX5000 IDU in a climate-controlled area.
- Installation should allow adequate air flow around the equipment. Air flow should be circulated and mixed with room air, not trapped in a closed space.
- When mounting the MTX5000 IDU in an enclosed rack with other equipment, it is good practice to allow spaces at the top and bottom of the rack, and to fill those spaces with grillwork instead of blank panels.

### Moisture

---

**WARNING** Indoor equipment is not designed to withstand water or moisture. If water does penetrate the chassis, it could cause equipment damage and/or create a safety hazard.

---



- Locate the equipment in an area protected from dripping water or excessive humidity.

### Cabling

In mobile installations, wiring is subject to extremes of temperature, humidity, and vibration. MRC recommends the following general practices be performed in all installations.

---

**CAUTION** Be sure the power being supplied matches the power required by the equipment.

---

**CAUTION** Power supply cords and cables must be protected. Do not run cords where they can be walked upon. Protect cables against pinching and chafing. Pay special attention to locations where the cables enter or exit an enclosure or make a sharp bend.

---

**CAUTION** Ensure that the electrical supply is protected by over current protection devices, as required by the applicable electrical codes.

---

- Secure all cables at close intervals along their entire lengths.
- Protect the cabling with additional sheathing or padding anywhere it passes through a hole or lays against an obstruction.
- Provide flex relief at any location where the cable must change direction sharply, to maintain a smooth bend and prevent kinking.
- Provide strain relief at each connector to absorb any pulling forces on the cable and prevent damage to the connector.

## 6.6 Power Connections

### 6.6.1 Power Requirements

The MTX5000 has the following power requirements.

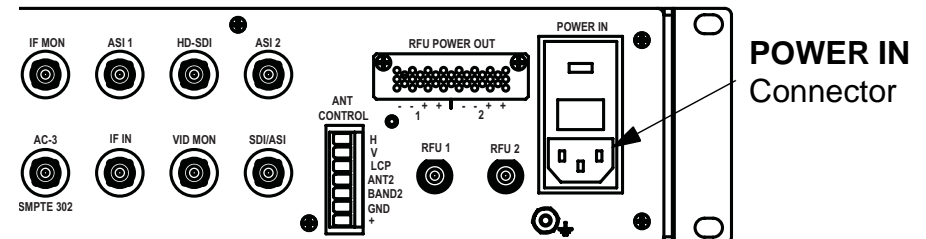
Supply Voltage: 120/240 VAC, 50/60 Hz  
IDU Power Consumption: 40 Watts Nominal  
Standard ODU Power Consumption: 65 Watts Nominal  
High Power ODU Power Consumption: 80 Watts Nominal

### 6.6.2 Power Supply and Distribution

AC power is supplied externally, from the mobile power source.

Power is distributed to the MTX5000 through the rear panel AC **POWER IN** connector. See Figure 6-2.

**Figure 6-2: AC POWER IN Connector**



**Power Connections** MRC supplies an AC power cable with each MTX5000.

**Additional Powering Notes** Check the electrical supply to be sure it can provide all the power needed at the site without overloading. Power ratings for equipment can be found on a rating plate, usually on the rear panel.

---

**CAUTION** *Be sure the power being supplied matches the power required by the equipment.*

---

---

**CAUTION** *Power supply cords and cables must be protected. Do not run cords where they can be walked upon. Protect cables against pinching and chafing. Pay special attention to locations where the cables enter or exit an enclosure or make a sharp bend.*

---

---

**CAUTION** *Ensure that the electrical supply is protected by overcurrent protection devices as required by the applicable electrical codes.*

---

## 6.7 Grounding

---

**CAUTION** *Be sure the equipment grounding follows applicable electrical codes.*

---

---

**CAUTION** *Never modify a grounded power plug to connect to an ungrounded receptacle.*

---

- The MTX5000 must be connected to the common ground on the installation. This common ground is often the vehicle ground.
- The ground wire should be as short as possible, and follow the straightest path possible.

## 6.8 Defining the Wiring Harness

This section describes how to define the wiring harness that connects the MTX5000 IDU to ODU. The wiring harness contains RF/Power cables and function cables.

Supplying main power to the MTX5000 IDU is covered in [Section 6.6 on page 6-4](#).

### 6.8.1 Steps to Define the Harness

Perform the following steps to define the wiring harness between the IDU and the ODU.

1. Select the type of RF/power cabling required. [See "Select the Type of RF/Power Cabling"](#).
2. Select the function cables required. [See Section 6.8.3 on page 6-7](#).
3. Determine the size of the wiring harness required. [See Section 6.8.4 on page 6-9](#).
4. When the wiring harness is fabricated, go to ["Installing the Fabricated Harness" on page 6-13](#).

### 6.8.2 Select the Type of RF/Power Cabling

The first step is to determine what type of RF and DC power cabling you will be using to connect the IDU to the ODU. There are three different options:

- Triax connectors (RF, control, and DC power in one cable). [See Figure 6-3 on page 6-6](#).
- Type "N" connectors (RF and control on one cable, DC power in another cable). [See Figure 6-4 on page 6-7](#).
- TNC connectors (RF and control in one cable, DC power in another cable). [See Figure 6-4 on page 6-7](#).

The MTX5000 system may be ordered with Triax, Type “N”, or TNC cable connectors. Existing installations may use Triax, Type “N”, or TNC cabling. ‘

**Special Note - Triax Installations** Over time, flexing and vibration can cause the connections inside the Triax connector to deteriorate, leading to high resistance in the DC circuit paths. This, in turn, can cause erratic and intermittent problems with the MTX5000 system.

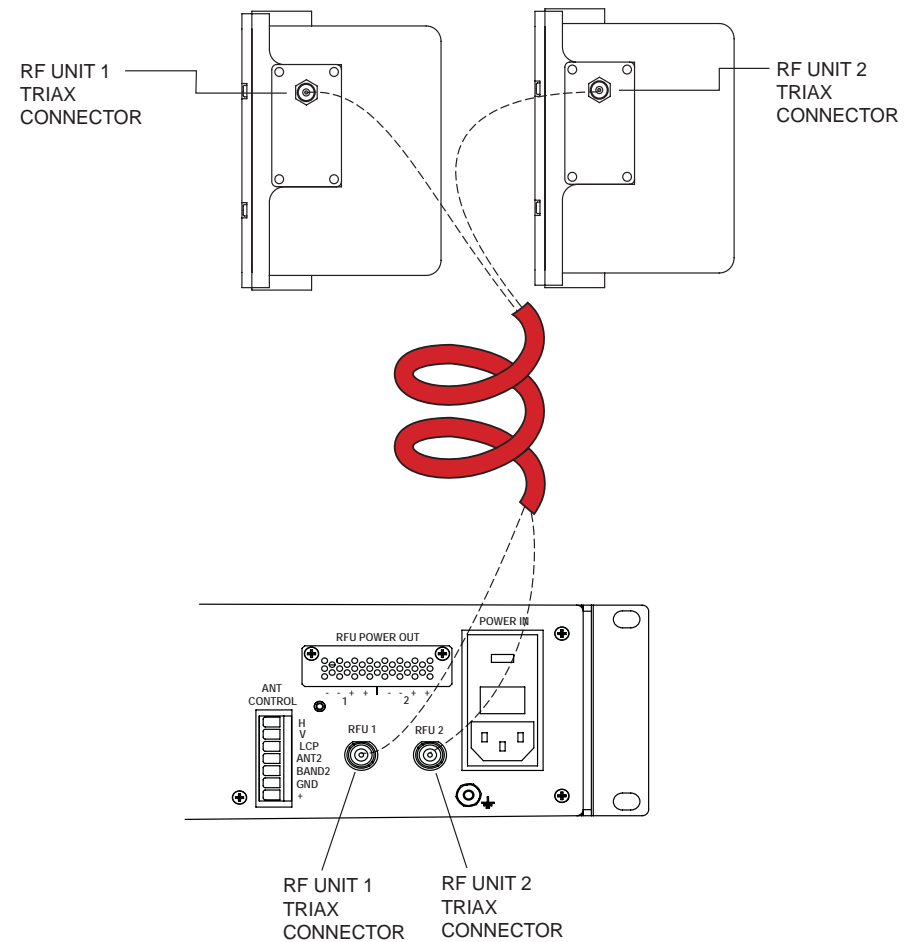
MRC recommends you avoid this possibility by performing the following:

- Install the Triax connector carefully, following the steps in [“Installing Triax Connectors” on page A-1](#).
- Support the Triax cable so that any movement of the cable does not apply stress to the Triax connector.

**Figure 6-3: Triax Cabling - Typical**

NOTE:

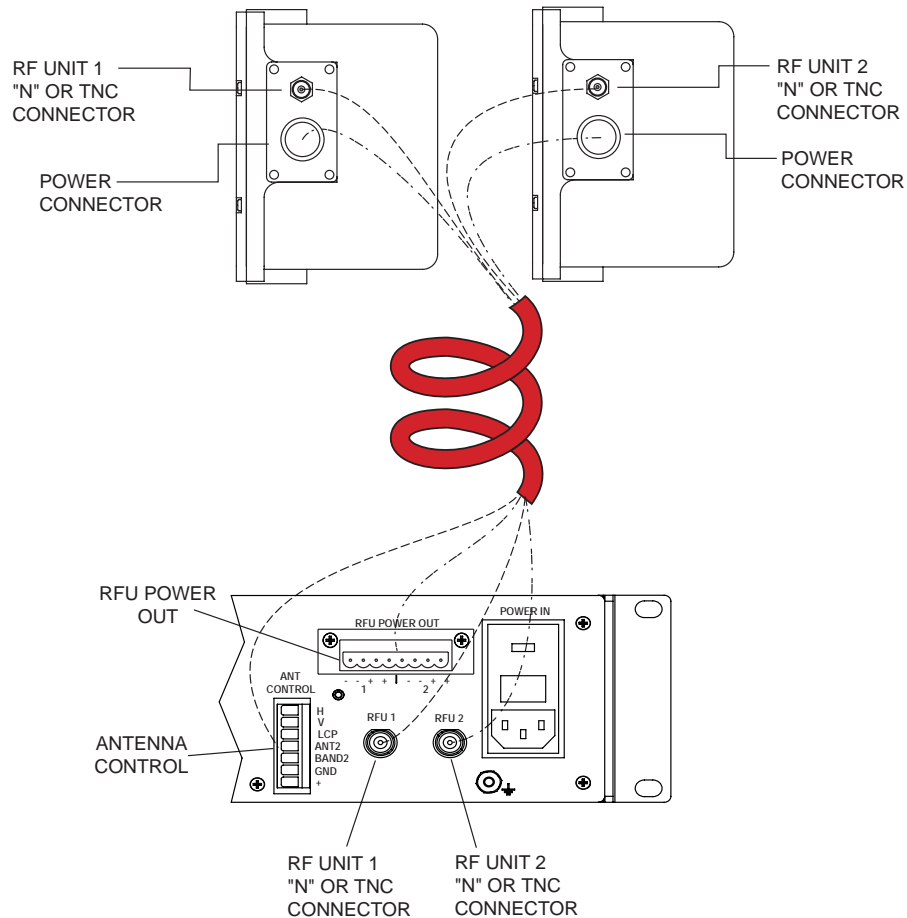
Connections from the ODU to the antenna are always Type “N”.



**Figure 6-4: Type “N” and TNC Cabling - Typical**

NOTE:

Connections from the ODU to the antenna are always Type “N”.



### 6.8.3 Select the Function Cables Required

In addition to the RF signal and DC power, the wiring harness may include several other cables which are used to control functions at the top of the mast. What cables need to be included in the wiring harness are application dependent.

You may choose to procure your own cables and Nycoil conduit and fabricate your own harness, or an ENG van integrator may procure or fabricate the harness for you.

**Selecting Function Cables** Table 6-1 on page 6-8 provides the most commonly requested functions. To select the cables for your wiring harness, perform the following:

1. Select the functions you require.
2. Read across the table to see what individual cables are applicable to your particular requirements. These are the cables that should be included in the harness.

**Table 6-1: Functions and Cables Required**

Function	Cable Description (Vendor Part Number)	Outside Diameter Inches [mm]
<b><i>IF + DC Power to ODU</i></b>		
IF signal + DC Power + ODU Control	TRIAX (Belden 8232)	.315 [8.0 mm]
<b><i>Antenna Functions</i></b>		
Antenna Polarization Control - Single Band Operation	6 Conductor 20 AWG stranded (Manhattan M33406)	.255 [6.47 mm]
Antenna Polarization Control - Dual Band Operation	10 Conductor 20 AWG stranded (Manhattan M33410)	.335 [8.5 mm]
<b><i>Existing Wiring</i></b>		
IF Signal + ODU Control	Coaxial, Type N Connectors (RG-214)	.425 [10.79 mm]
2A20 POL CTL/PA200/PA700	5 Conductor 20 AWG Stranded (Belden 9445)	.239 [6.07 mm]
Standard ODU Type N and TNC Connectors	9 Conductor 20 AWG Stranded (Belden 9455)	.317 [8.05 mm]
High Power ODU Type N Connector	7 Conductor 16 AWG Stranded (Belden 8621) <b><i>(Recommended for both Standard and High Power ODU installations)</i></b>	.458 [11.63 mm]
<b><i>Nycoil Conduit</i></b>		
	Nycoil Conduit (Nycoil 19081)	1" [25.4 mm]
	Nycoil Conduit (Nycoil 20001)	1.25" [37.5 mm]

## 6.8.4 Determine the Size of Harness Required

**Length** The length of your harness is set by the length of the mast when fully raised. Refer to Table 6-2 to locate typical dimensions, as shown in Figure 6-5. Note these are only typical dimensions. Your harness may be different.

Table 6-2: Harness Dimensions

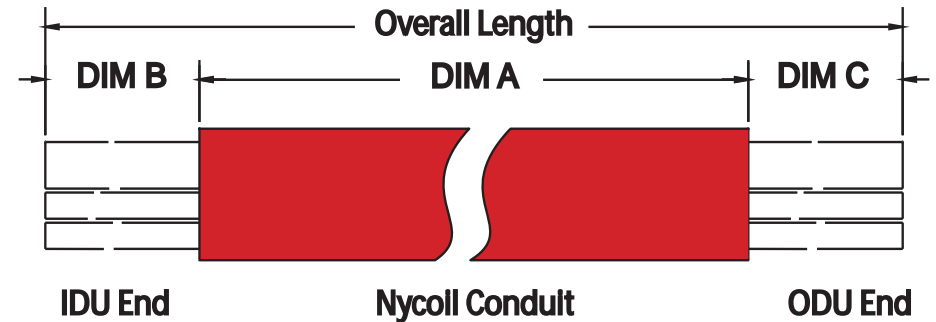
Mast Height	Overall Length	Dim. A	Dim. B	Dim. C
42' [12.8 M]	104' [31.7 M]	74' [22.5 M]	20' [6.0 M]	10' [3.0 M]
48' [14.6 M]	116' [35.4 M]	86' [26.2 M]	20' [6.0 M]	10' [3.0 M]
58' [17.7 M]	136' [41.5 M]	106' [32.3 M]	20' [6.0 M]	10' [3.0 M]

The formula used to determine theoretical end-to-end cable lengths (See Figure 6-5) is as follows:

$$\text{Overall Length} = (\text{DIM A} - 5 \text{ ft.}) \times 2 + \text{DIM B} + \text{DIM C}$$

For example, with a mast height of 58 ft., minus 5 ft. inside the truck = 53 ft.  $\times 2 = 106 \text{ ft.} + 10 \text{ ft.} + 20 \text{ ft.} = 136 \text{ ft.}$

Figure 6-5: Harness lengths



A = Length of Nycoil only

B = Length of cables outside Nycoil on IDU end

C = Length of cables outside Nycoil on RFU (RFU) end

## 6.9 Cabling Requirements

### CAUTION

To avoid potential problems, existing wiring harnesses must be carefully examined for evidence of damage, corrosion, or broken wire strands, and any damage detected must be repaired before a new MTX5000 system is placed into service.

### CAUTION

Failure to provide sufficient current carrying capacity between the MTX5000 IDU and the ODU(s) may cause performance issues, including dropouts in transmission, and may cause damage to the equipment or to the installation.

**MRC strongly recommends using a 4-conductor, 16 AWG wire combination for DC power that supports Standard and High Power ODUs.**

Specifically, wiring should be in accordance with [Table 6-3](#) for Standard ODU use and [Table 6-4 on page 6-11](#) for High Power ODU use.

MRC recommends that installations of the MTX5000 IDU and ODU be carefully considered, especially where the DC power to the ODU is concerned. All ODUs used to support digital (COFDM) transmission require higher linearity and therefore require more input current to the power amplifiers to achieve acceptable levels of Modulation Error Ratio (MER) performance. This is especially true of the optional High Power ODUs.

For new Nycoil installations where the cable length is 160 feet (48.8 M) or less, MRC suggests two 16 AWG multi-strand conductors in parallel for both power and return. In a new installation, this is less likely an issue, however for an existing installation, other alternatives may be more appropriate.

The following factory recommendation applies to existing installations. At the very least, all cabling in an existing installation must be inspected to ensure that no corrosion or broken strands are present, especially if new conductors are not used.

The acceptable cable lengths for existing Standard power ODU installations, or alternatives to the recommendation, are provided in [Table 6-3](#) as a function of mast height. The recommended lengths are end-to-end cable length vs. mast height.

**Table 6-3: Existing Installation Cable Lengths - Standard Power ODU**

Mast Height	RF Connector Type	Minimum Wiring for Power and Return	Assumed Maximum Cable Length
≤ 58 Feet	Triax	Triax	160 ft. (48.8.0 M)
≤ 58 Feet	N	4 Conductors of 16 AWG (2 Power, 2 Return)	160 ft. (48.8 M)
≤ 58 Feet	N	4 Conductors of 20 AWG (2 Power, 2 Return)	140 ft. (42.7 M)
≤ 58 Feet	N	7 Conductors of 20 AWG (4 Power, 3 Return)	160 ft. (48.8 M)
≤ 58 Feet	TNC	8 Conductors of 20 AWG (4 Power, 4 Return)	160 ft. (48.8 M)

The acceptable cable lengths for high power ODU installations, or alternatives to the recommendation, are provided in [Table 6-4 on page 6-11](#) as a function of mast height. The recommended lengths are end-to-end cable length vs. mast height.



**Table 6-4: Existing Installation Cable Lengths - High Power ODU**

Mast Height	RF Connector Type	Minimum Wiring for Power and Return	Assumed Maximum Cable Length
≤ 42 Feet	Triax	Triax	104 ft. (31.7 M)
≤ 58 Feet	N	4 Conductors of 16 AWG (2 Power, 2 Return)	160 ft. (48.8 M)
≤ 20 Feet	N, TNC	4 Conductors of 20 AWG (2 Power, 2 Return)	60 ft. (18.3 M)
≤ 52 Feet	N	7 Conductors of 20 AWG (4 Power, 3 Return)	124 ft. (37.8 M)
≤ 52 Feet	TNC	8 Conductors of 20 AWG (4 Power, 4 Return)	124 ft. (37.8 M)

Contact MRC for assistance to determine the effective maximum cable length for any desired configuration, as required.

### 6.9.1 MTX5000 System Type “N” Connector Interface

#### **CAUTION**

To avoid potential problems, existing wiring harnesses must be carefully examined for evidence of damage, corrosion, or broken wire strands.

Any damage detected must be repaired before a new MTX5000 system is placed into service.

#### **Note**

The MTX5000 IDU is available with either the **RFU 1** or with both **RFU 1** and **RFU 2** rear connectors. If you have only one ODU, disregard connections and references to the second ODU (RFU 2).

If your MTX5000 IDU and ODU contains the Type “N” connector **RFU 1** and **RFU 2** option, the IDU and ODU can be connected using an existing wiring harness after inspection, subject to the limits called out in [“Cabling Requirements” on page 6-9](#).

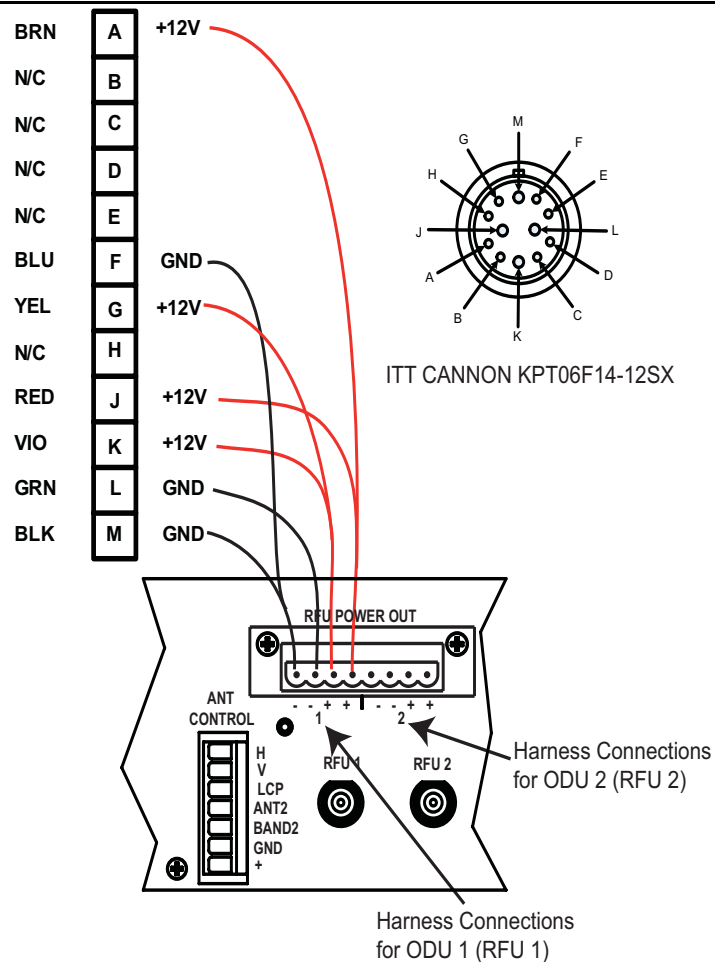
**ODU Connections** The existing connector(s) at the ODU end of the wiring harness will connect directly to your MTX5000 ODU(s). Verify that all connections have been completed, as shown in [Figure 6-6 on page 6-12](#).

**IDU Connections** At the IDU end of the wiring harness, verify the connections are as shown in [Figure 6-6 on page 6-12](#). Connections for ODU 2 (RFU 2) are identical to those for ODU 1 (RFU 1).

The ITT Cannon KPT06F14-12SX connector is utilized on MTX5000 IDU/ODU configurations that contain the Type “N” **RFU 1** and **RFU 2** connector option.

Figure 6-6: ODU Wiring

**Note** If only two conductors each for power and return are used, contacts **J**, **K**, **L**, and **M** must be used. Contacts **J**, **K**, **L**, and **M** will accommodate up to 16 AWG single conductor wiring; all other contacts will accommodate 20 AWG single conductor wiring.



## 6.9.2 MTX5000 System TNC Connector Interface

### CAUTION

To avoid potential problems, existing wiring harnesses must be carefully examined for evidence of damage, corrosion, or broken wire strands.

Any damage detected must be repaired before a new MTX5000 system is placed into service.

If your MTX5000 IDU and ODU contain the TNC **RFU 1** and **RFU 2** connectors, the IDU and ODU can be connected using an existing harness,

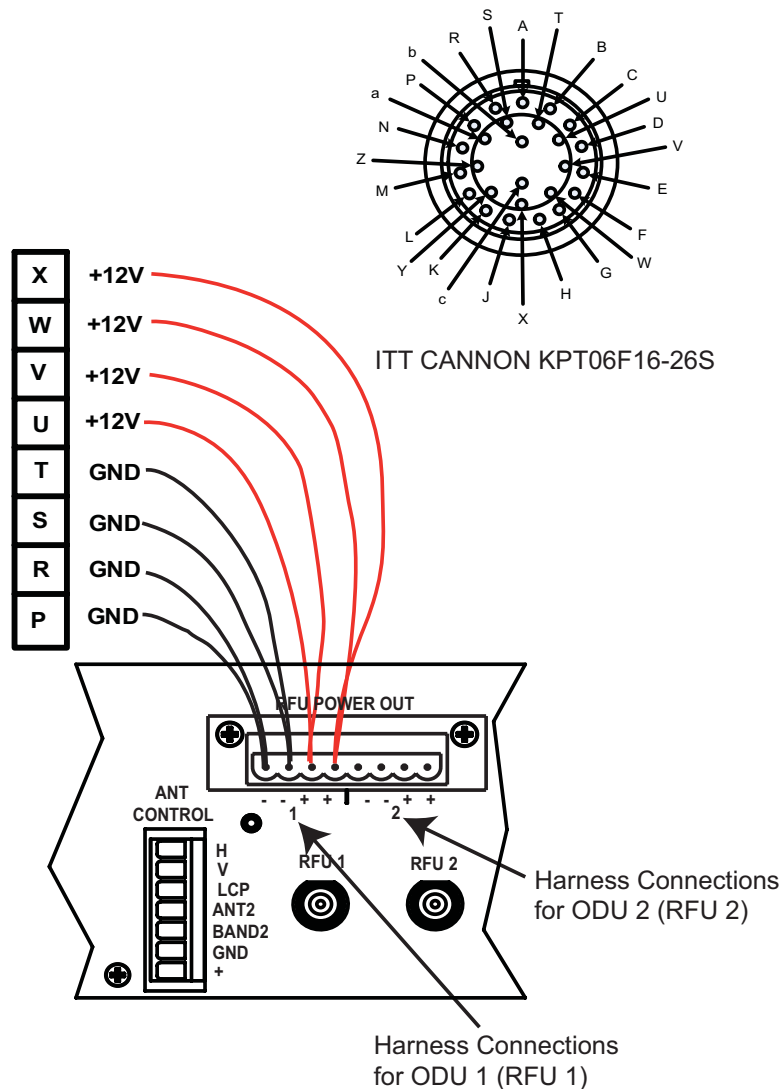
**ODU End** The existing power connector at the ODU end will plug in directly to your ODU.

**IDU End** At the IDU end, the harness connector will not plug directly into your IDU. You must cut off the terminal block at the IDU end and must connect the wiring harness to the Weidmuller connector supplied with the IDU. Verify the new connections are as shown in [Figure 6-7 on page 6-13](#). Connections for ODU 2 (RFU 2) are identical to ODU 1 (RFU 1).

The actual number of wires in your harness, and their gauges, may differ from the standard harness. To provide enough current to the RFU, MRC recommends the minimum power and ground connections specified in [“Cabling Requirements” on page 6-9](#)

**Figure 6-7: TNC Connector Option Wiring**

**Note** All contacts will accommodate 20 AWG single conductor wiring only.



## 6.10 Installing the Fabricated Harness

Wiring mounted in a moving vehicle is subject to extremes of temperature, humidity, and vibration. MRC recommends the following good general practices:

- Secure the cabling at close intervals along its entire length.
- Protect the cabling with additional sheathing or padding anywhere it passes through a hole or lays against an obstruction.
- Provide flex relief at any location where the cable must change direction sharply, to maintain a smooth bend and prevent kinking.
- Provide strain relief at each connector to absorb any pulling forces on the cable and prevent damage to the connector.

## 6.11 Installing the Outdoor Unit

This section provides the steps required to mount the ODU to a QuikSet QPT-90 Pan & Tilt Assembly, using the Mounting Plate that was provided with your MRC antenna. The mounting hardware is provided with the RFU.

The Mounting Plate is designed to fit the following antennas:

- MRC 2A20/7A30
- MRC 2A20SS/7A30SS
- MRC Ellipse 2000

Details on attaching these antennas to the Mounting Plate can be found in the installation manual that came with your MRC antenna.

If you are installing the RFU in a different configuration, consult the installation instructions that came with your hardware.

When you have installed the RFU, go to [“Making the Connections”](#) on page 6-15.

### 6.11.1 Site Preparation

Each installation will be different. In general, MRC recommends the following sequence:

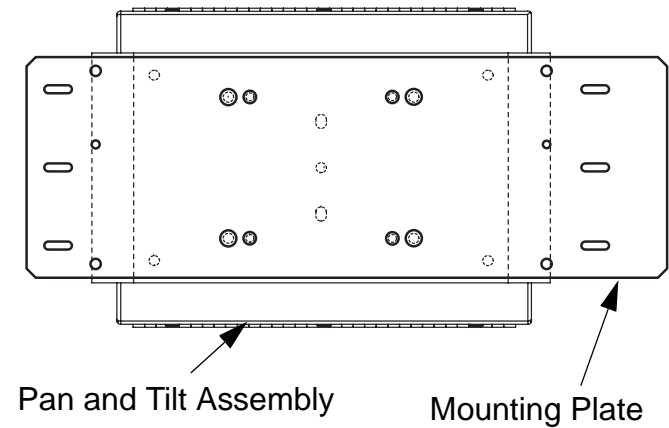
- Install the mast.
- Lower the fabricated wiring harness over the mast.
- Mount the Pan & Tilt to the mast.
- Mount the RFU(s) to the Pan & Tilt. See [“Mounting the ODU”](#).
- Mount the antenna to the Pan & Tilt.

### 6.11.2 Mounting the ODU

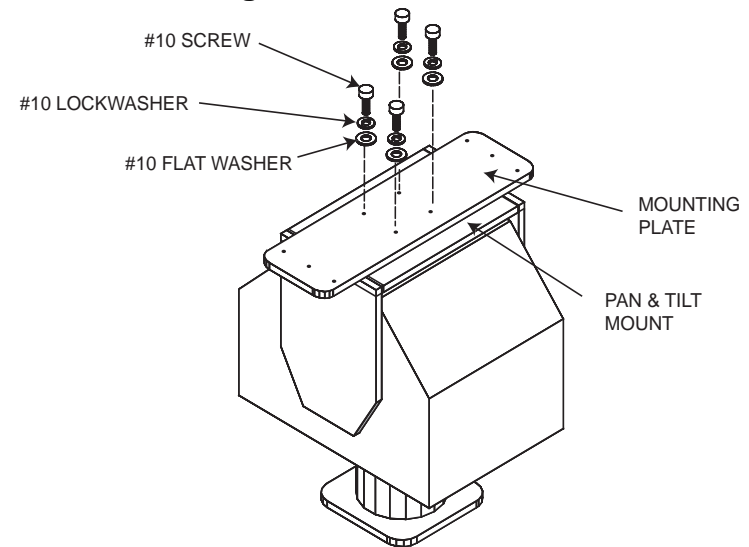
The following instructions describe mounting one ODU (RFU). To mount a second ODU, repeat the steps.

1. Attach the Mounting Plate to the Pan & Tilt Assembly.
  - Align the Mounting Plate to the Pan & Tilt mount as shown in [Figure 6-8](#).
  - Attach the Mounting Plate to the Pan & Tilt mount using #10-32 screws, lock washers, and flat washers supplied. See [Figure 6-9](#).
2. Attach the ODU to the Mounting Plate.

**Figure 6-8: Alignment of Mounting Plate to Pan and Tilt**



**Figure 6-9: Mounting Plate Attachment to Pan and Tilt**



---

**CAUTION**

Screws must not penetrate into the holes on the ODU housing more than **.25 in. (6.35 mm)**.

**DO NOT substitute longer screws** unless your installation requires the additional length.

Over-length screws can crack the housing when tightened.

---

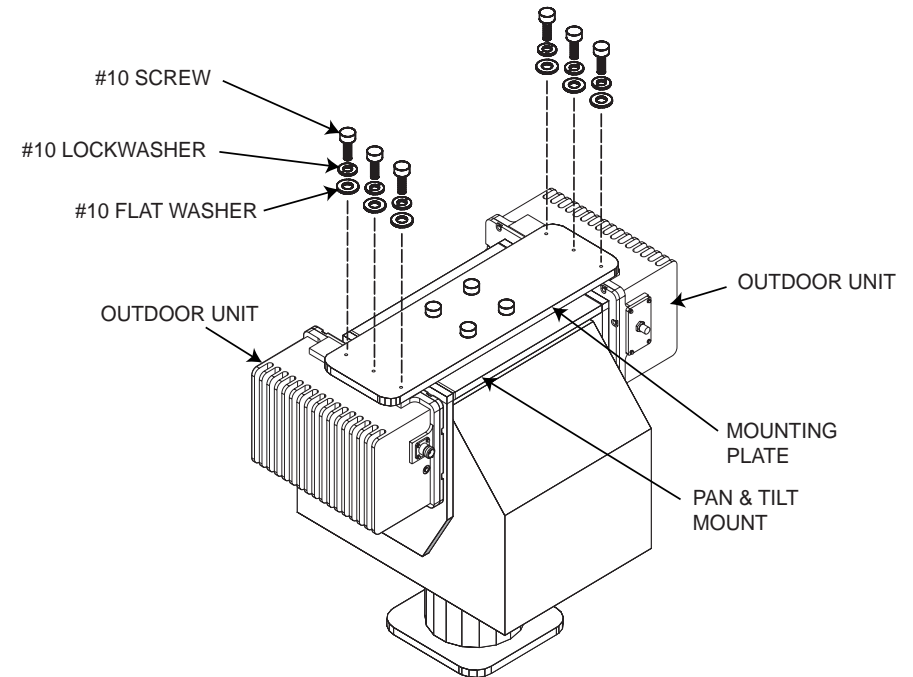
**CAUTION**

To ensure proper cooling of the ODU, the unit must always be mounted so that the cooling fins are vertical and are not blocked from free air flow.

---

3. Align the holes in the ODU with the 3 elongated holes at one end of the Mounting Plate.
4. Attach the ODU to the mounting plate using the #10-32 screws, lock washers, and flat washers supplied. See [Figure 6-10](#).

**Figure 6-10: Attaching ODU(s) to Mounting Plate**



## 6.12 Making the Connections

Now that the IDU and ODU(s) are in place and the harness is installed, make the connections at each end of the harness. While every installation is different, here are some general guidelines:

- When you're done making all connections, re-check all connections before powering up the MTX5000.
- If you need to install the Triax connector(s) onto the cable, refer to [Appendix A, "Installing Triax Connectors" on page A-1](#).

## 6.12.1 Mast Top Connections

For connections at the top of the mast, refer to [Figure 6-11 on page 6-17](#) which shows a typical installation with a parabolic antenna and an RF switch. Refer to [Figure 6-12 on page 6-18](#) which shows a typical installation with a Parabolic antenna without an RF switch. Additional resources are as follows:

- For details on connections at the ODU, refer to [Figure 6-11 on page 6-17](#) and [Figure 6-12 on page 6-18](#).
- For details on connections to the antenna(s) refer to the Installation Guide that came with the antenna.
- If you are using an MRC RF Switch, refer to the Installation Guide that came with the Switch.

## 6.12.2 IDU Connections

Refer to [Figure 6-13 on page 6-19](#) and [Table 6-5 on page 6-20](#) for connections to the IDU.

Figure 6-11: Typical Installation with RF Switch and Triax

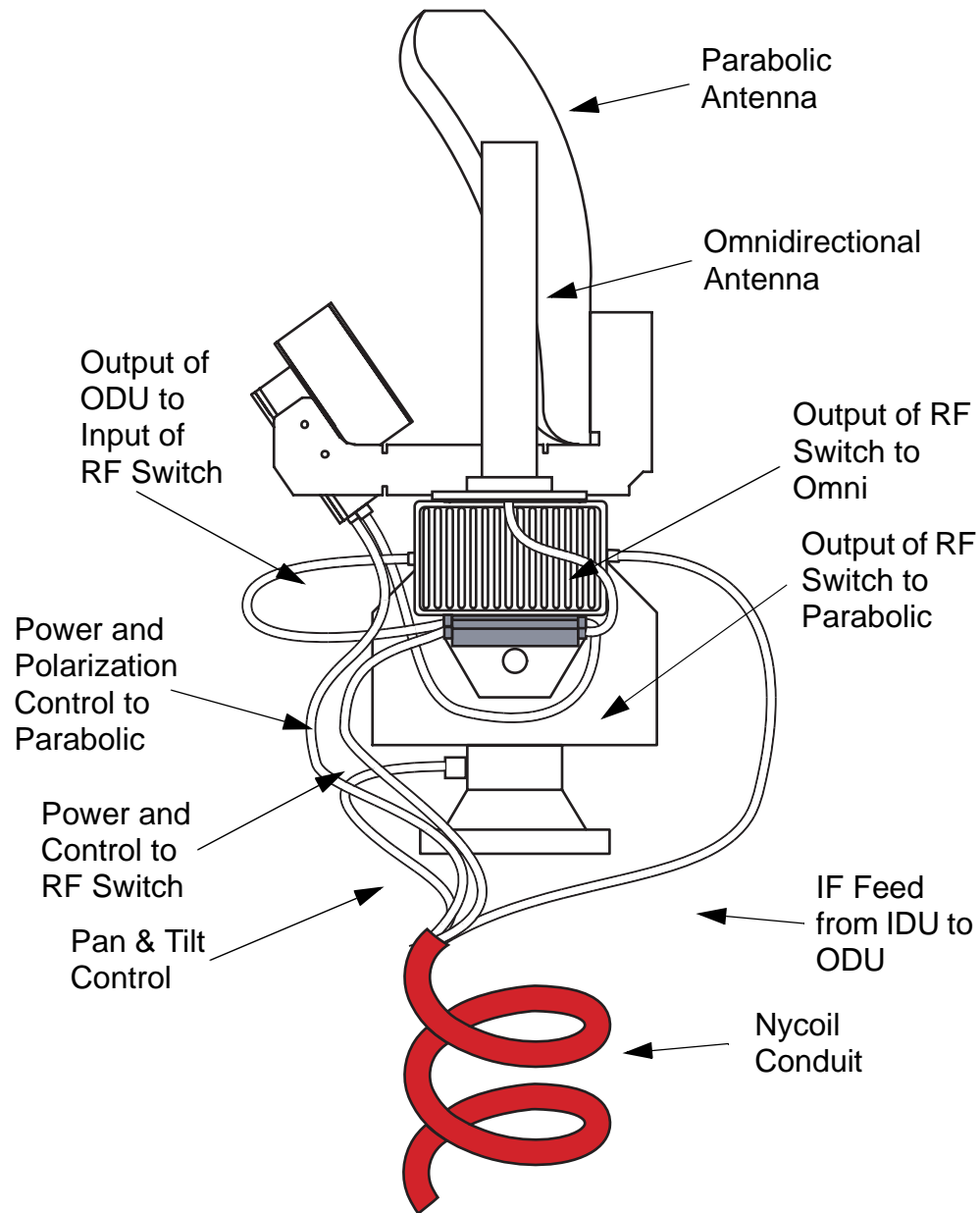
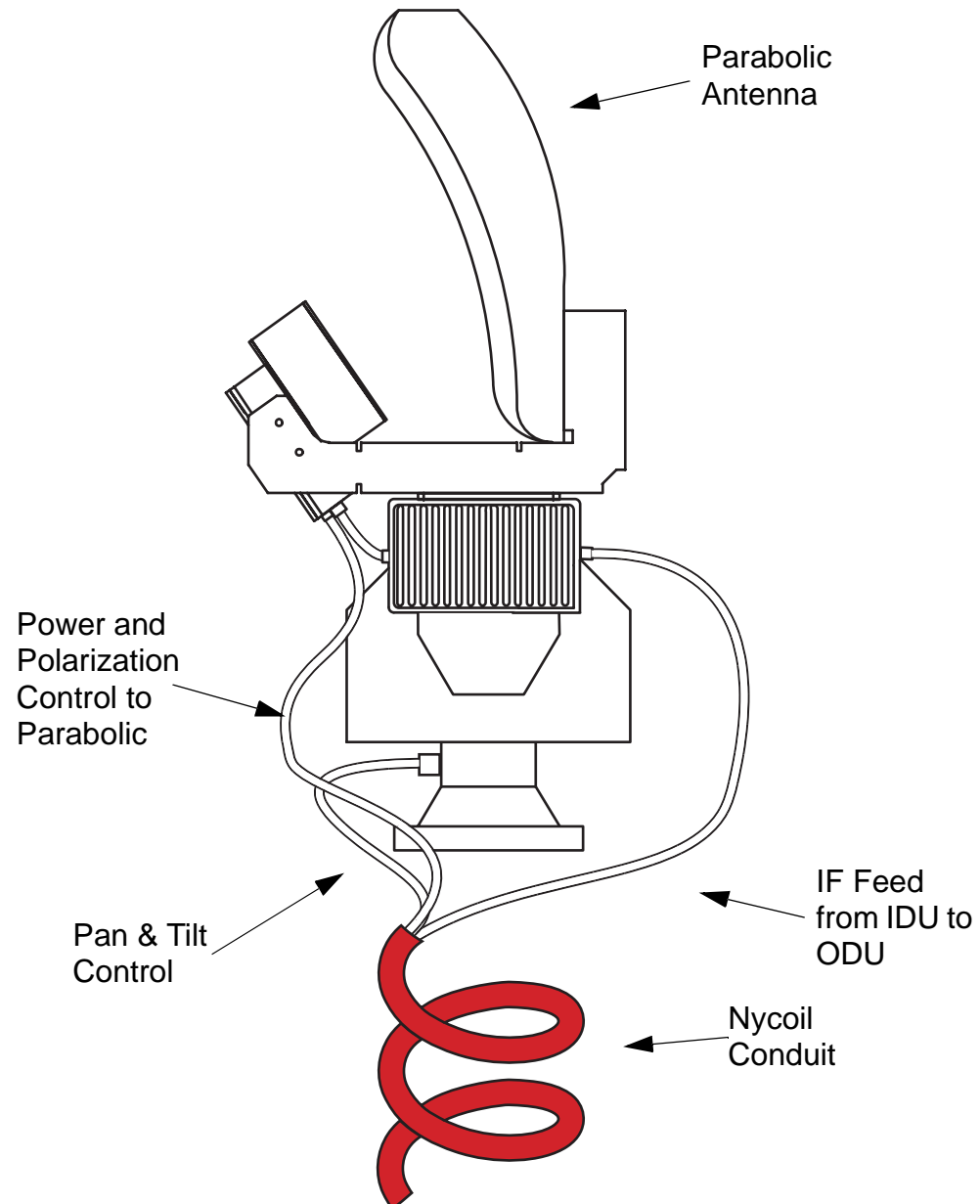
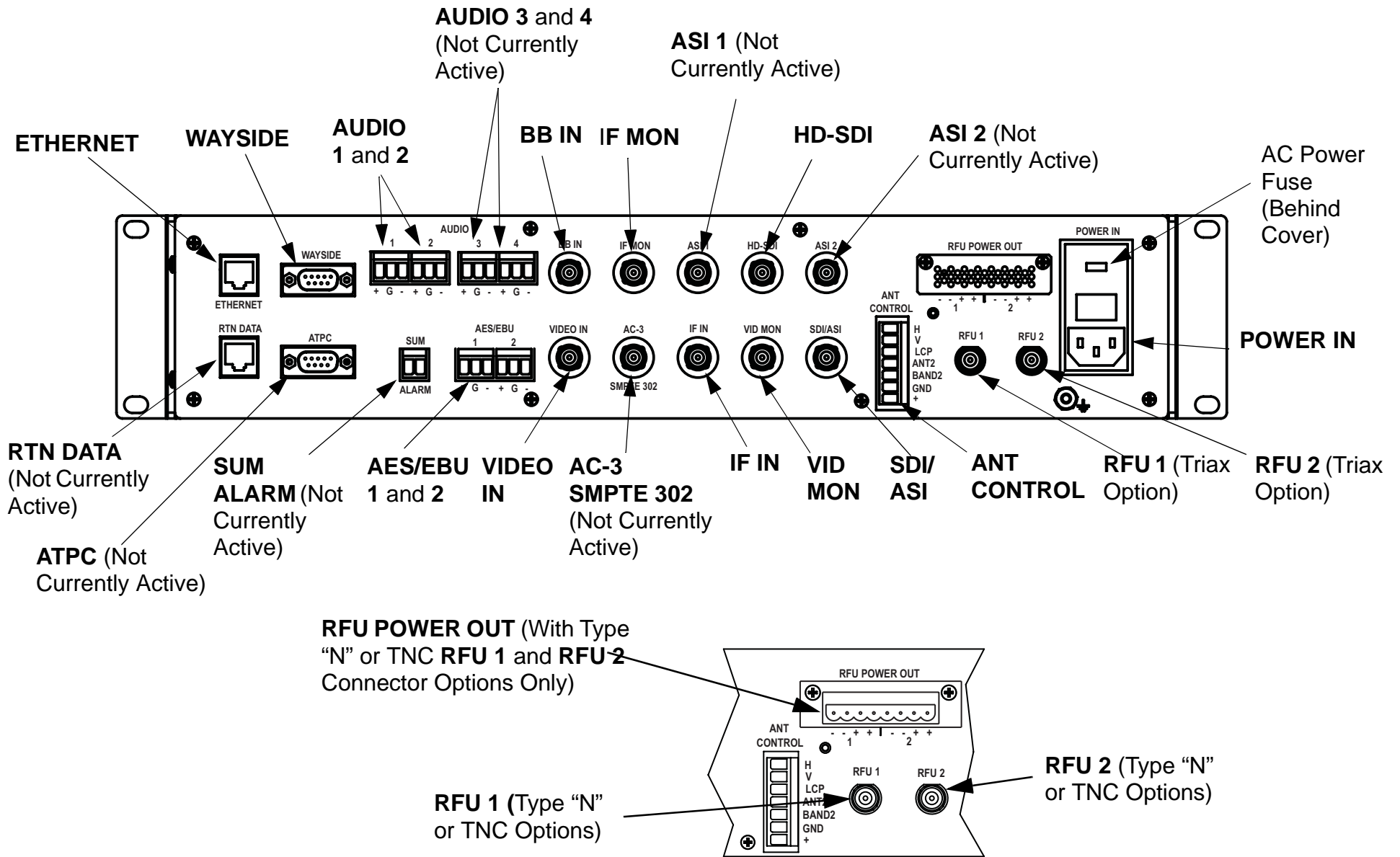


Figure 6-12: Typical Installation with Parabolic and Triax





**Figure 6-13: IDU Rear Panel Connections**



**Table 6-5: IDU Rear Panel Connections**

Connector	Type	Function	Comments
<b>ETHERNET</b>	RJ-45 connector	Provides connection via your web browser to a PC at a remote location for remote control of the MTX5000 IDU. See <a href="#">"Remote Control Operations"</a> on page 6-26	Also provides connection to the optional Remote Access Subnotebook PC for mobile operation remote control. See <a href="#">"Remote Control Operations"</a> on page 6-26.
<b>WAYSIDE</b>	9-Pin male D-connector	The <b>WAYSIDE</b> connector provides Wayside data output from the MPEG module.	See <a href="#">"Wayside Data Connections"</a> on page 6-24 for pinouts.
<b>AUDIO 1</b> thru <b>AUDIO 4</b>	<ul style="list-style-type: none"> <li>• <b>AUDIO 1</b> - 3 pin Weidmuller</li> <li>• <b>AUDIO 2</b> - 3 pin Weidmuller</li> <li>• <b>AUDIO 3</b> - 3 pin Weidmuller</li> <li>• <b>AUDIO 4</b> - 3 pin Weidmuller</li> </ul>	The <b>AUDIO 1</b> thru <b>AUDIO 4</b> male 3-pin Weidmuller connectors provide analog/digital switchable stereo audio signal inputs to the FMT or MPEG modules. ( <b>AUDIO 3</b> and <b>4</b> are currently inactive.)	See <a href="#">"Analog Audio Inputs"</a> on page 6-25 for pinouts.
<b>BB IN</b>	75 ohm BNC female connector	The <b>BB IN</b> connector provides baseband input video from an external baseband source.	Composite analog signal - video + audio subcarriers
<b>IF MON</b>	75 ohm BNC female connector	The <b>IF MON</b> connector provides a 70 MHz IF output for external signal monitoring purposes.	70 MHz IF output
<b>ASI 1</b>	75 ohm BNC female connector	(Currently inactive.)	(Currently inactive.)
<b>HD-SDI</b>	75 ohm BNC female connector	The <b>HD-SDI</b> connector provides the HD/SDI data stream input to the IDU.	The MTX5000 meets SMPTE 292M specifications for HD-SDI. The user is responsible for using cables that meet SMPTE 292M specifications.
<b>ASI 2</b>	75 ohm BNC female connector	(Currently inactive.)	(Currently inactive)

**Table 6-5: IDU Rear Panel Connections (Continued)**

Connector	Type	Function	Comments
<b>RFU POWER OUT</b>	8-pin Weidmuller male connector	The <b>RFU POWER OUT</b> connector provides DC power to the ODU(s).	The <b>RFU POWER OUT</b> connector is present only if the <b>RFU 1</b> and <b>RFU 2</b> connectors are type "N" or TNC connectors. See "ODU Power" on page 6-26 for pinouts.
<b>RTN DATA</b>	RJ-45 connector	(Currently inactive.)	(Currently inactive.)
<b>ATPC</b>	9-pin male D-connector	(Currently inactive.)	(Currently inactive.)
<b>SUM ALM</b>	2-pin Weidmuller male connector	(Currently inactive.)	(Currently inactive.)
<b>AES/EBU</b>	Two 3-pin male Weidmuller connectors	The two AES/EBU 3-pin Weidmuller connectors provide external AES/EBU digital audio inputs to the unit.	See "Digital Audio Inputs" on page 6-25 for pinouts.
<b>VIDEO IN</b>	75 ohm BNC female connector	Input for analog video. Signal is connected to both the analog video modulator module and to the MPEG/COFDM module.	Input level = 1Vpp Input impedance = 75 ohms
<b>AC-3 SMPTE 302</b>	75 ohm BNC female connector	(Currently inactive.)	(Currently inactive.)
<b>IF IN</b>	75 ohm BNC female connector	The <b>IF IN</b> connector provides a 70 MHz IF input to the unit.	Input level = 0 to -10dBm Input impedance = 75 ohms (70 MHz IF with analog or digital modulation)
<b>VID MON</b>	75 ohm BNC female connector	Analog video output to monitor the analog color bar generator. Does not contain program video. Used for setting characters generated by color bar generator.	Output is only available if analog color bar generator is installed.
<b>SDI</b>	75 ohm BNC female connector	The <b>SDI</b> connector provides SDI inputs to the unit.	The MTX5000 meets SMPTE 259M specifications for SDI. The user is responsible for using cables that meet SMPTE 259M specifications.

**Table 6-5: IDU Rear Panel Connections (Continued)**

Connector	Type	Function	Comments
<b>ANT CONTROL</b>	7-pin Weidmuller connector	The <b>ANT CONTROL</b> connector provides control for antenna polarization, antenna band selection, the RF switch, and also provides DC power for the antenna and the RF switch.	A 7-pin Weidmuller female connector is provided for new system applications. For retrofit applications, the existing 5-pin and 2-pin Weidmuller female connectors may be retained. <a href="#">See Table 6-6 on page 6-22</a> for pinouts.
<b>RFU 1 and RFU 2</b>	<ul style="list-style-type: none"> <li>• Triax</li> <li>• N or TNC (optional)</li> </ul>	<ul style="list-style-type: none"> <li>• IF + DC Power + Control to RFU</li> <li>• IF + Control to RFU (optional)</li> </ul>	Connector type depends on which connector ordered. <b>RFU 2</b> connector present only if 2 band option ordered.
<b>POWER IN</b>	AC - IEC 3 prong recessed male	Supplies power to the MTX5000 system.	110 - 220 VAC, 50/60 Hz
Grounding Lug	#8-32 threaded post	Connection to chassis ground	

**Table 6-6: Antenna Control - Feed and Relay Connections**

Pin (New Applications)	Pin (Retrofit Applications)	Function	Description	Comments
		<b>Antenna Control</b>		
1	1	<b>H</b>	Selects horizontal polarization.	Connect pins 1, 2, or 3 to GND (pin 6 or 1 in <b>Feed/Relay Power</b> below) to select desired polarization. If all are left ungrounded, antenna defaults to right circular (RC) polarization. Selecting <b>Ant. Pol.</b> option button options on color LCD display panel causes each pin, in turn, to be grounded or all to be ungrounded. When ungrounded, should have +24 volts DC returning from antenna.
2	2	<b>V</b>	Selects vertical polarization.	
3	3	<b>LCP</b>	Selects left circular polarization.	

**Table 6-6: Antenna Control - Feed and Relay Connections (Continued)**

Pin (New Applications)	Pin (Retrofit Applications)	Function	Description	Comments
4	4	<b>ANT 2</b>	Selects second antenna using RF switch.	Connect GND from RF switch here. Selecting <b>Antenna</b> option button options on color LCD display panel to select <b>Direct</b> grounds this pin and causes RF switch to select the directional antenna. Selecting the <b>Omni</b> option ungrounds this pin and switches back to the omnidirectional antenna.  When ungrounded, should have +24 volts DC returning from RF switch.
5	5	<b>BAND 2</b>	Selects second band on dual band systems.	Selecting <b>RF Band</b> option button options on color LCD display panel grounds this pin and causes band switch inside ODU to operate. Selecting the alternate band from the <b>RF Band</b> option button options ungrounds this pin and switches back to Band 1.  When ungrounded, should have +24 volts DC returning from antenna.
		<b>Feed/Relay Power</b>		
6	1	<b>GND</b>	Ground	
7	2	<b>+</b>	Supplies +24 VDC to antenna and RF switch.	

## 6.13 Wayside Data Connections

### 6.13.1 Wayside Connections

The Wayside channel is a simplex data channel transmitting data from the MTX5000 system to a receiver system. For pinouts, see [Table 6-7](#).

**Table 6-7: WAYSIDE Data Connections**

Connector Information	Pin	Signal Description
9-Pin, Male, "D" Connector.	1	UART_TX
	2	UART_RX
	3	Return
	4	NC
	5	NC
	6	NC
	7	NC
	8	NC
	9	NC

### 6.13.2 Compatibility

MRC has verified that the Wayside channel is compatible with the following receivers:

- STRATA Receiver Unit (RXU) with MPEG decoding
- STRATA Receiver Control Unit (RCU) with MPEG decoding.
- Tandberg Alteia IRD (Integrated Receiver Decoder)

## 6.14 Audio Connections

### 6.14.1 Audio Inputs

The MTX5000 IDU provides inputs for both analog or digital audio, depending on how the MTX5000 is configured. The IDU configurations all use 3-pin Weidmuller connectors. The analog **AUDIO 1** thru **AUDIO 4** and digital **AES/EBU** connectors are mounted on the rear panel of the IDU. (The **AUDIO 3** and **4** and **AES/EBU** connectors are currently inactive.)

The MTX5000 provides options for separate audio and video outputs, as well as analog composite and embedded digital formats. Analog audio inputs are factory-configured for each customer's requirements.

- Each MTX5000 is shipped with pre-installed factory Presets, as specified and ordered by the customer.
- Hardware - Internal cabling connections from the MTX5000 **AUDIO** connectors to the FMR and/or MPEG/COFDM modules are factory-configured for each MTX5000 ordered.

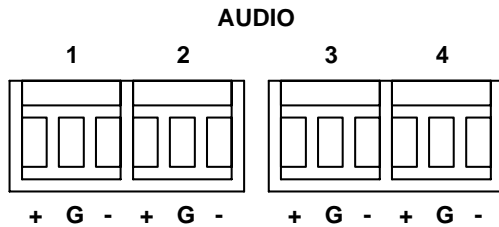
The MTX5000 provides a maximum of four analog audio circuits. Each audio circuit is a 3-wire balanced circuit capable of carrying one tone or voice signal. An audio circuit can carry one analog balanced channel or two digital AES/EBU channels.

- Analog - Four monaural or two stereo channels carried on two **AUDIO** connectors (**AUDIO 3** and **4** connectors are currently inactive.)
- Digital AES/EBU - Two digital channels carried on each **AES/EBU** connector.

## 6.14.2 Analog Audio Inputs

The pinouts of the **AUDIO 1** thru **4** analog connectors are shown in [Figure 6-14](#) and in [Table 6-8](#).

**Figure 6-14: AUDIO 1 thru 4 Connectors**



**Table 6-8: AUDIO 1 thru AUDIO 4 Connections**

Pin	Function	Comments
<b>AUDIO 1</b>		
+	Audio (+)	Input impedance = 600 ohms
G	GND	
-	Audio (-)	
<b>AUDIO 2</b>		
+	Audio (+)	Input impedance = 600 ohms
G	GND	
-	Audio (-)	
<b>AUDIO 3 (Currently inactive)</b>		
+	Audio (+)	Input impedance = 600 ohms
G	GND	
-	Audio (-)	
<b>AUDIO 4 (Currently inactive)</b>		

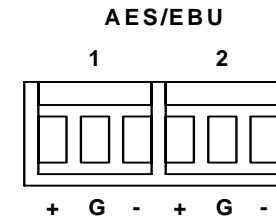
**Table 6-8: AUDIO 1 thru AUDIO 4 Connections (Continued)**

Pin	Function	Comments
+	Audio (+)	Input impedance = 600 ohms
G	GND	
-	Audio (-)	

## 6.14.3 Digital Audio Inputs

The pinouts of the **AES/EBU** channel **1** and **2** digital connectors are shown in [Figure 6-15](#) and in [Table 6-9](#).

**Figure 6-15: AES/EBU 1 and 2 Connectors**



**Table 6-9: AUDIO 1 thru AUDIO 4 Connections**

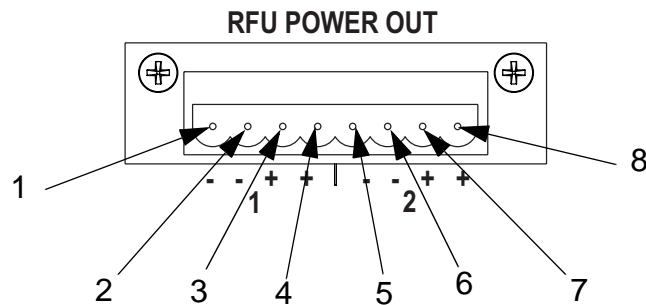
Pin	Function	Comments
<b>AES/EBU 1</b>		
+	Audio (+)	Input impedance = 600 ohms
G	GND	
-	Audio (-)	
<b>AES/EBU 2</b>		
+	Audio (+)	Input impedance = 600 ohms
G	GND	
-	Audio (-)	

## 6.15 ODU Power

DC power is supplied to the ODU(s) from the IDU **RFU POWER OUT** 8-pin Weidmuller male connector. This connector is present only on MTX5000 systems with the optional **RFU 1** and **RFU 2** type “N” or TNC connectors.

**RFU POWER OUT** connector pinouts are shown in [Figure 6-16](#) and [Table 6-10](#). If you only have one ODU (RFU), power must be provided from the **RFU 1** section of the connector.

**Figure 6-16: RFU POWER OUT Connector**



**Table 6-10: RFU POWER OUT Connections**

Pin	Function	Comments
1	GND	ODU 1 Ground
2	GND	ODU 1 Ground
3	+12 VDC	ODU 1 DC Power
4	+12 VDC	ODU 1 DC Power
5	GND	ODU 2 Ground
6	GND	ODU 2 Ground
7	+12 VDC	ODU 2 DC Power
8	+12 VDC	ODU 2 DC Power

## 6.16 Remote Control Operations

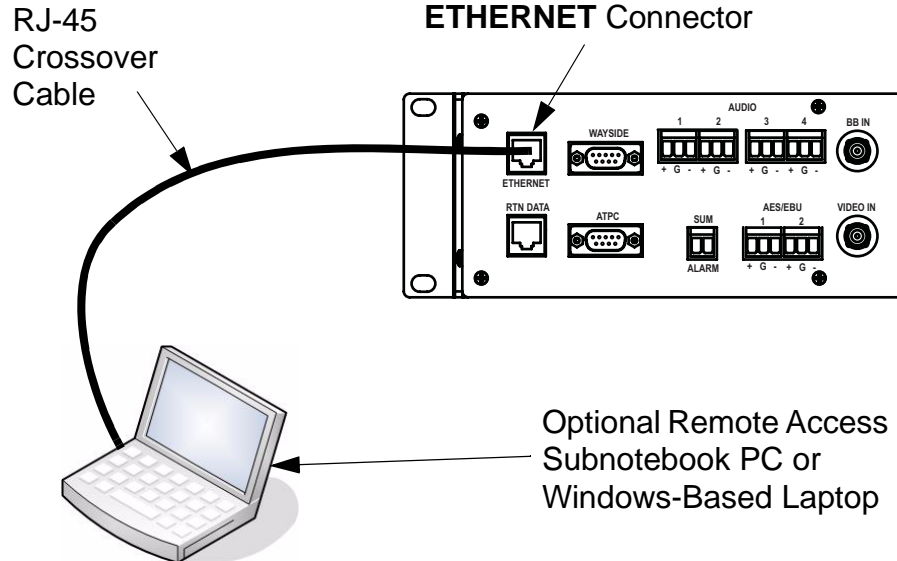
The MTX5000 system may be controlled remotely using either the optional Windows-based Remote Access Subnotebook PC or a Windows-based laptop PC. The optional Remote Access Subnotebook PC is a rugged, low cost, remote control option. Using either laptop eliminates the need for a separate panel-mounted remote control panel to control the MTX5000 system.

An RJ-45 crossover cable is required for connection to either PC for mobile remote control operations. [See Figure 6-17 on page 6-27](#). The RJ-45 crossover cable is connected between the MTX5000 IDU rear panel **ETHERNET** connector and the RJ-45 connector on the optional Remote Access Subnotebook PC or Windows-based laptop PC.

An RJ-45 crossover cable is provided with each optional Remote Access Subnotebook PC. If you use a Windows-based PC in lieu of the optional Remote Access Subnotebook PC, the RJ-45 crossover cable may be obtained from MRC or from local electronics stores.



**Figure 6-17: Mobile Operations Remote Control - Typical**



The MTX5000 system may also be controlled using a Remote Access Subnotebook or a Windows-based laptop PC from a remote location. When controlling the MTX5000 system from a remote location, the remote PC is connected to the MTX5000 system via the Ethernet. A standard RJ-45 cable is used when connecting to the MTX5000 system via the Ethernet. A crossover cable may not be used from a remote location for connection to the Ethernet.

## 6.17 Powering Up

When the wiring and installations are completed, it is time to power up the MTX5000 system. As good practice, you should make a final check of all wiring and hardware installations before power is applied.

### 6.17.1 Checks Before Power-Up

---

**CAUTION** *Be sure the power being supplied matches the power required by the equipment.*

---

Here are your final pre-power-up checks:

- Double check to verify all wiring harnesses and cables are connected to the correct connectors.
- Make sure all connections are fully mated, properly mated, and are secured.
- Verify an ODU is properly connected to the IDU.
- Verify all assemblies are properly installed and all mounting hardware is properly tightened.

### 6.17.2 Initial Power-Up

---

**CAUTION** *If power is accidentally lost or if the power switch is pressed to off, do not immediately power up the MTX5000 again.*

*Internal software corruption may occur if power is applied immediately after a power loss or if the power switch is pressed to off and immediately back to on.*

*To avoid possible software corruption, wait a minimum of 10 seconds before applying power or before pressing the power switch to on.*

---

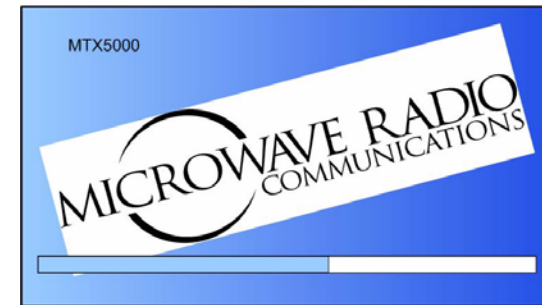
The procedure required to apply power to the MTX5000 system is contained in the following steps.

1. Verify the power cable is properly connected to the MTX5000 IDU rear panel **POWER IN** AC power connector.
2. Verify all coaxial cables and cable connectors are properly connected to the rear panel connectors and verify the ODU is properly connected.
3. Verify the MTX5000 power cable is connected to AC power of the correct type and voltage.
4. Verify the AC power source is turned on.
5. Raise the power switch protective switch cover, press the power switch, observe the symbol on the switch illuminates green, and close the protective switch cover.

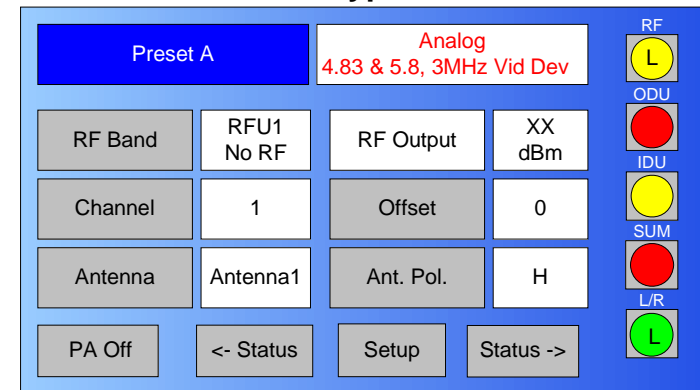
introduction screen will be displayed on the color LCD display panel. See [Figure 6-18](#).

- After another short delay (approximately 30 seconds), the Main screen will be displayed on the color LCD display panel. See [Figure 6-19](#).

**Figure 6-18: Introduction Screen**



**Figure 6-19: Main Screen - Typical**



**Note** When power is applied to the MTX5000, it will automatically enter the local normal user mode of operation.

The MTX5000 will return to the last settings that were in use when the unit was powered down, but the MTX5000 will not resume transmitting if the unit was transmitting when it was powered down.

If the MTX5000 was in the remote mode when power was removed, the IDU will not return to the remote mode.

6. The normal power-up sequence is as follows:
  - After a short delay (approximately 30 seconds), the

7. If everything appears to be normal, test the performance of your MTX5000 by setting up a link and transmitting video and audio.
  - If you have any problems, refer to the [“Troubleshooting” Chapter on page 4-1](#).

## 6.17.3 Power Down

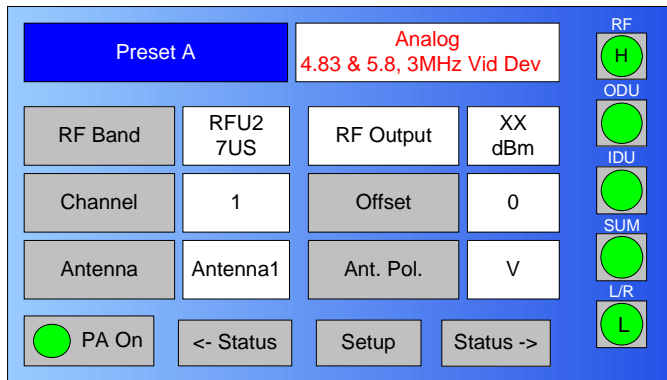
### CAUTION

To allow proper shutdown of MTX5000 internal software, the Main screen must always be displayed when the power switch is pressed to off.

Failure to properly power down the MTX5000 with the Main screen displayed may corrupt the internal software.

1. Verify the Main screen is displayed on the color LCD display panel. See Figure 6-20.

Figure 6-20: Main Screen - Typical



2. Raise the power switch protective switch cover, press the power switch, observe the symbol on the switch goes off, and close the protective switch cover.
3. Set the power source off, as required.

## 6.18 Product Modifications

The product you purchased has been carefully designed and tested, and is warranted to meet specifications when connected and operated as described in this manual.

---

**Note** If you modify a product without authorization from MRC, you will void the warranty.

---

For a complete Warranty statement, refer to the “Notices” section at the front of this manual.



# 7 Replacement Parts and Supported Repairs

## 7.1 Chapter Overview

This chapter identifies replacement parts and supported repairs applicable to the MTX5000 Transmitter System (MTX5000).

**Since there are no supported field repairs on the MTX5000, the only parts available are external cables and power fuses.**

## 7.2 External Cables and Adapters

The external cables and test cables for the MTX5000 are listed in [Table 7-1](#). If you need something that is not listed, ask your Sales Representative or consult the factory.

**Table 7-1: MTX5000 System Cables**

Description	Comments
AC Power Cable (120/240 VAC)	Connects AC power to the MTX5000 IDU.
Triax Cable Kit	Connects MTX5000 IDU to the ODU. (IDU Triax <b>RFU 1</b> and <b>RFU 2</b> connector option only.)
Color Bar Generator Test Cable	Connects optional Analog Color Bar Generator
USB-A to USB-B Adapter	Connects USB memory stick to MTX5000 IDU front panel USB-B connector

## 7.3 AC Power Fuses

The MTX5000 Indoor Unit (IDU) operates on the following AC power:

- 120/240 VAC, 50/60 Hz

Fuse ratings for the AC power sources are listed in [Table 7-2](#).

**Table 7-2:**

Operating Voltage	Fuse Rating
120 VAC, 50/60 Hz	3.0A SB 250V 3AG or 5 x 20 mm
240 VAC, 50/60 Hz	1.5A SB 250V 3AG or 5 x 20 mm

## 7.4 Supported Repairs

***There are NO supported field repairs to the MTX5000 IDU or the ODU.***

***Return the unit(s) for factory repair.***

***If you attempt field repair, you risk damaging your equipment.*** If your equipment is under warranty, you may also affect your warranty coverage.

The MTX5000 is designed to be compact, rugged and reliable.

The MTX5000 Indoor Unit (IDU) and the Outdoor Unit (ODU) require specialized test equipment and software to calibrate amplitude and frequency characteristics after repair. In addition, sealing the ODU enclosure after repair requires exacting techniques and special fixtures to ensure weather resistance of the unit.



# 8 Theory of Operation

## 8.1 Chapter Overview

This chapter provides additional details about the design and function of the MTX5000 Transmitter System (MTX5000). This chapter is intended to complement information contained in the “Product Description” Chapter on page 2-1.

The descriptions in this chapter assume you are already familiar with the information contained in Chapter 2. We recommend you review that chapter before beginning to read this one.

Here are the topics covered:

Topic	Page
<a href="#">System Architecture</a>	8-1
<a href="#">General</a>	8-1
<a href="#">Architecture</a>	8-1
<a href="#">MPEG Encoding and COFDM Transmission</a>	8-2
<a href="#">Analog Video Encoding and FM Modulation</a>	8-2
<a href="#">MTX5000 User Interface</a>	8-2
<a href="#">ODU RF Output</a>	8-3
<a href="#">MTX5000 Internal Software</a>	8-3
<a href="#">Outdoor Unit Details</a>	8-5

## 8.2 System Architecture

### 8.2.1 General

The MTX5000 is a van-mounted, High Definition (HD) ready,

video transmission system capable of both analog and digital operation in different formats. The MTX5000 system provides a sophisticated user interface with an intuitive keypad scheme, touch screen, and an adjustable color LCD display. The MTX5000 system consists of the MTX5000 Indoor Unit (IDU) and the mast-mounted Outdoor Unit(s) (ODU).

A fully equipped MTX5000 package is HD ready and provides a robust HD link from field to studio. Several digital video input formats are accepted, as well as analog composite for Digital Video Broadcasting - Terrestrial (DVB-T) and analog FM transmission. In addition, the MTX5000 can accept several digital audio input formats and up to four analog audio inputs for analog or digital transmission.

The MTX5000 has several mast-mounted ODU configurations available. These ODUs contain integrated RF up conversion circuitry and high power RF amplifiers for maximum power and signal quality. With the demands of digital modulation, the ODUs have been optimized for improved Modulation Error Ratio/Error Vector Magnitude (MER/EVM) performance with digital transmissions.

### 8.2.2 Architecture

The MTX5000 system consists of the IDU and the ODU(s). The IDU is responsible for video encoding, modulation, system control, and power distribution. The ODU contains RF up conversion circuitry and a power amplifier.

The ODU is mounted at the top of the van mast and is responsible for all aspects of the RF transmission. Modulated signals are passed from the IDU to the ODU using a 70MHz IF signal. In addition, the IDU and ODU communicate through a bidirectional Frequency-Shift Keying (FSK) modem. This FSK link allows the IDU to control, calibrate, and monitor the state of the mast-mounted ODU.

A digital attenuator in the ODU RF chain allows you to transmit at high or low power or to increment the power in single dB steps for advanced fine tuning.

Inside the IDU, a control processor is responsible for configuring the various sub-systems within the radio. The main processor stores radio information in selectable presets that can be recalled by the user.

The MTX5000 employs an advanced MPEG video encoder and digital modulator. The MTX5000 includes the FMT modulator, COFDM modulator and MPEG encoder, DC power supply, and signal control and distribution boards, depending upon the options contained in your MTX5000. A typical functional block diagram of the MTX5000 is shown in [Figure 8-1 on page 8-4](#).

### 8.2.3 MPEG Encoding and COFDM Transmission

The MTX5000 is capable of encoding both Standard Definition and High Definition video (depending on license). Available inputs include SD Serialized Digital Interface video (SD-SDI), HD-SDI, and Composite Video (CV). Audio input formats include analog, AES/EBU, and AC-3 SMPTE-302. The encoder is also capable of encoding an RS-232 signal as Wayside data.

The MTX5000 is capable of generating a fully DVB-T compliant output signal. This provides a robust digital link in any hostile transmission environment.

### 8.2.4 Analog Video Encoding and FM Modulation

When in the analog FM mode, the MTX5000 will accept a standard composite video input. It will also accept up to four analog audio inputs. The FM analog signal is useful when working with older legacy equipment or when an analog transmission is desired.

## 8.2.5 MTX5000 User Interface

**Local Mode Operation** The MTX5000 IDU front panel provides monitoring and control of the MTX5000 system. The color LCD display panel with touch screen and the function keys are used to select control and diagnostic menu screens for both the IDU and the ODU.

The user interacts with the system through the touch-screen or function keys. The user interface is broken into a normal user mode and a system setup or advanced features mode.

Normal user mode menus permit basic radio control without exposing you to the more complicated setup features available in the advanced features sections. The advanced features can be password protected to prevent an unwitting user from changing critical settings.

Option buttons displayed on the IDU color LCD display panel are used to control Preset selection, RF band selection, channel selection, offset selection, antenna selection, antenna polarization, transmitter operation (on or off), power (low or high), and to monitor the status of the IDU and ODU. For additional information, see the [“Routine Operation” Chapter on page 3-1](#).

The front panel color LCD display panel is also used to select local or remote control operation of the MTX5000 system.

**Remote Mode Operation** The MTX5000 system may also be operated from a remote location via the **ETHERNET** connector mounted on the rear panel of the IDU. The IDU can be connected to a PC at a remote location via your web browser. The remote mode allows you to control the MTX5000 in the normal user mode from the remote location using the PC display, mouse, and keyboard. You cannot perform system setup advanced features from the remote location.



Control of the local/remote mode of operation can only be controlled from the IDU. You cannot change the local/remote operating mode from the remote location.

For more information on remote operation, see [“Using the MTX5000 in Remote Mode” on page 3-60](#).

## **8.2.6 ODU RF Output**

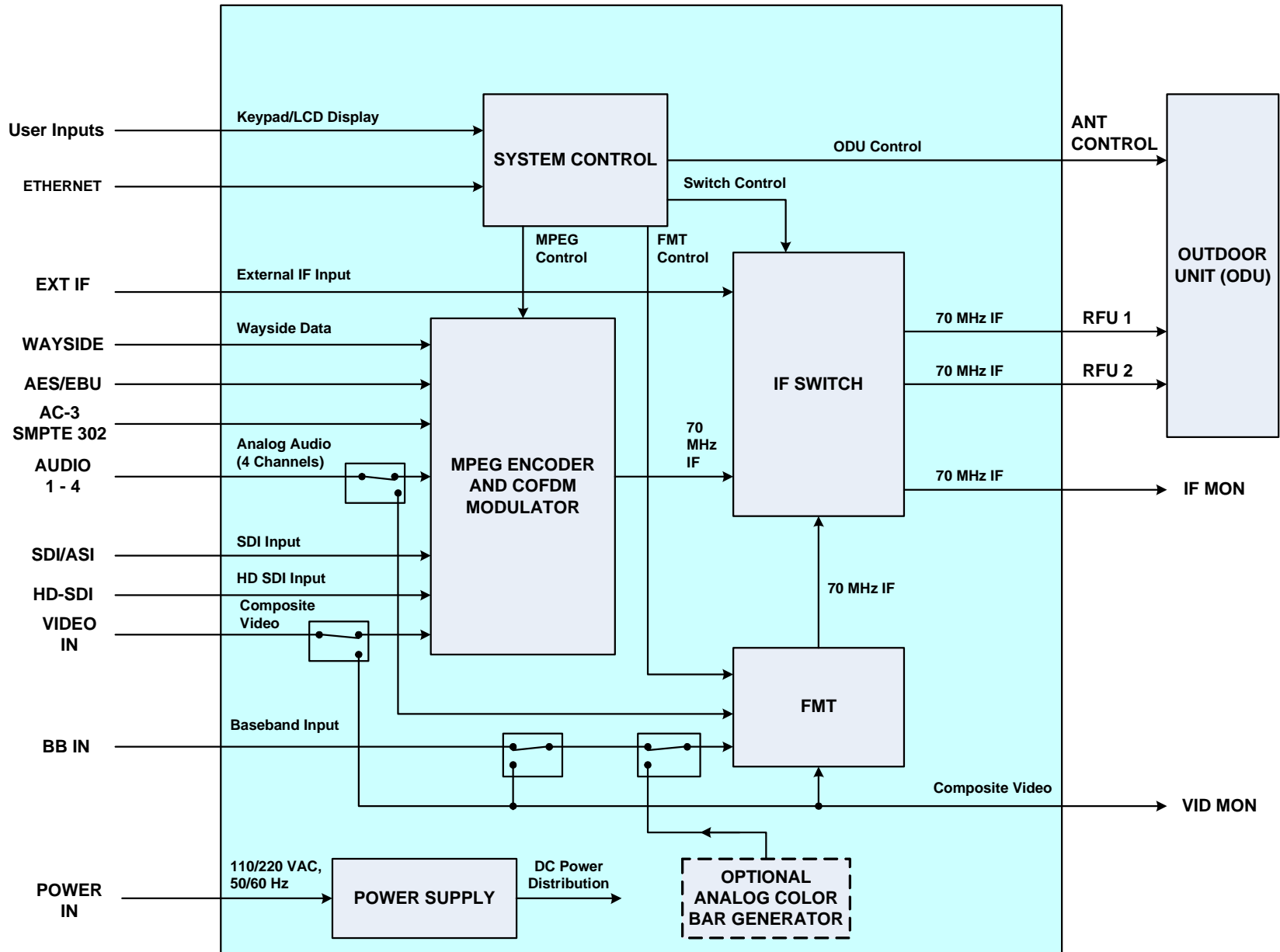
The MTX5000 communicates with the ODU to set operating frequencies and power levels. A 70 MHz IF signal is up-converted to the RF band of operation. Before up conversion, a digital attenuator adjusts the signal output power based on calibration data and user input.

## **8.2.7 MTX5000 Internal Software**

The MTX5000 internal software package consists of an embedded controller software package.

For additional information on user interface through use of the front panel color LCD display screen with touch screen and function keys, see the [“Routine Operation” Chapter on page 3-1](#).

Figure 8-1: MTX5000 Functional Block Diagram - Typical



## 8.3 Outdoor Unit Details

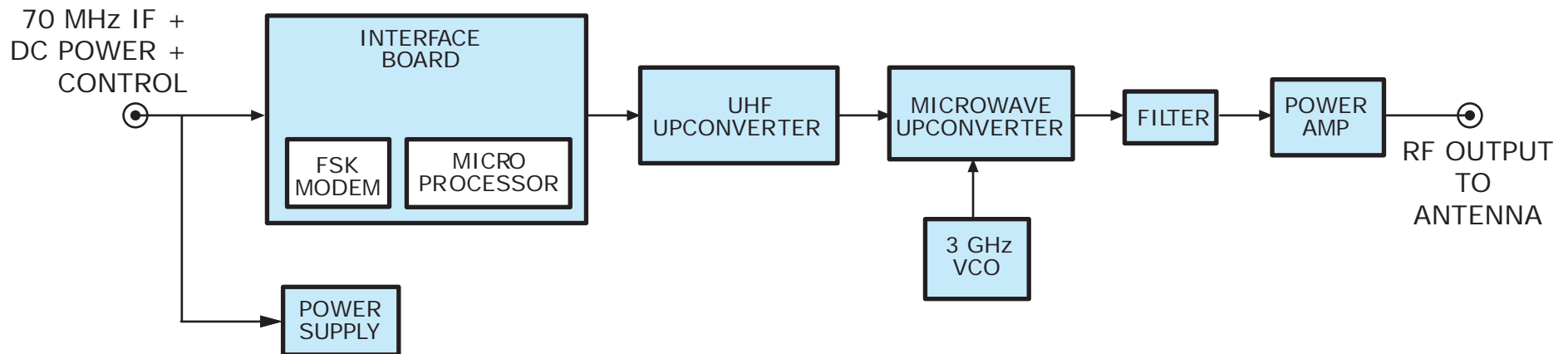
The MTX5000 ODU processes the IF signal from the MTX5000 IDU and generates the higher power microwave signal that is fed to the antenna. The ODU contains the following components:

- An IF interface module, containing a 2 FSK modem. The modem communicates with the IDU modem to send and receive alarms and operating data.
- A power supply, which converts the 12 VDC from the IDU into +15 VDC, -15 VDC, and +5 VDC for use by the other RFU modules.
- A UHF up-converter, which converts the 70 MHz IF signal to 900 MHz.

- A 3 GHz local oscillator, whose frequency is set by a control voltage from the interface module (a Voltage-Controlled Oscillator, or VCO).
- A microwave mixer/up-converter that mixes the 3 GHz with the the 900 MHz signal, to produce the frequency desired. For the 7 GHz and 13 GHz bands, this also includes a frequency doubler or tripler.
- A bandpass filter to eliminate unwanted frequency components.
- A Power Amplifier (PA) that amplifies the resulting signal to the power level desired.

A functional block diagram of the ODU is shown in [Figure 8-2](#).

**Figure 8-2: ODU Block Diagram**





# A Installing Triax Connectors

## A.1 Appendix Overview

Installing Triax connectors on a Triax cable is an exacting job. If not performed correctly, it can lead to intermittent or permanent failures due to vibration, moisture, etc.

As a service to our customers, MRC is providing a copy of our Triax Cable Assembly Instructions. We have found this procedure to work well and the results to be reliable.

## A.2 Sealing

For any outdoor application, such as mast top connections, we recommend you seal all connections with self-fusing butyl rubber or silicone tape. **Ordinary plastic electrical tape and cloth friction tape are not recommended.**

A good general practice is as follows:

- Connect and tighten the connector
- Begin wrapping the tape tightly against the enclosure, and wrap in a spiral back toward the cable
- Overlap each turn with the next turn by about half its width
- Continue wrapping and overlapping until the tape extends at least 2 inches beyond the connector.

Self-fusing tape can be purchased from industrial supply companies such as Grainger ([www.grainger.com](http://www.grainger.com)) and McMaster-Carr ([www.mcmaster.com](http://www.mcmaster.com)). Self-fusing tape is also available at larger hardware stores such as DoitBest.com ([www.doitbest.com](http://www.doitbest.com)).

REVISIONS			
REV	DESCRIPTION	DATE	APPROVED
A	REL PER ECO 00140 PO	000525	BT
B	ECO 4170-2 LJS	040427	EB
C	ECO 5084-2 EB	050322	LJS
D	ECO 5124-5 LJS	050422	EP
F	ECO 6308-3 NS	060926	BW
F	ECO 7066-7 NS	070321	BW

\*\*FOR FIRST TIME INSTALLATION OF A NEW RADIO, PERFORM STEPS 1 THROUGH 6 USING PARTS SUPPLIED WITH RADIO.

IF INSTALLING AN UPGRADED OR REPAIRED ODU TO AN EXISTING SYSTEM, PERFORM STEP 6 USING SHRINK TUBING SUPPLIED WITH RETURNED ODU.

CONTENTS OF KIT: QTY MRC P/N

- |                          |   |           |
|--------------------------|---|-----------|
| 1. CONNECTOR "TRIAX" (M) | 2 | 52160-100 |
| 2. SHRINK TUBING 6" LG   | 3 | 52160-16  |
| 3. DOCUMENT              | 1 | 907002    |

NOTE: ONE OF THE 3 PCS OF SHRINK TUBING NEEDS TO BE CUT INTO TWO 3" LENGTHS OF TUBING.

STEP 5 REQUIRES ONE 6" SHRINK TUBING ON EACH END.

STEP 6 REQUIRES ONE 3" SHRINK TUBING ON EACH END.

SEE SEPARATE PARTS LIST

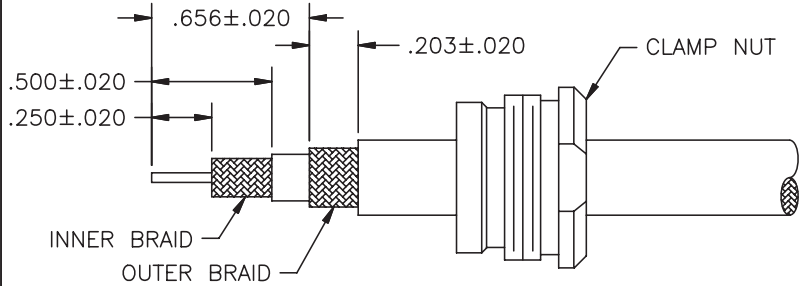


DO NOT SCALE DRAWING

ALL MATERIALS MUST BE RoHS COMPLIANT.

CONTRACT NO.		<b>MICROWAVE RADIO COMMUNICATIONS</b>	
APPROVALS	DATES	TITLE	
DRAWN P.O'TOOLE	000207	CABLE KIT, TRIAX (M)	
CHECKED B.THOMAS	000525	ASSEMBLY INSTRUCTIONS	
ENG. A.M.O.	000621	SIZE A	CAGE CODE OBDP7
J MIODUSZEWSKI	000711	DWG NO.	907002
		SCALE NONE	REV. F
			WGT
			SHEET 1 OF 5

REVISIONS			
REV	DESCRIPTION	DATE	APPROVED
F	SEE SHT 1	-	-

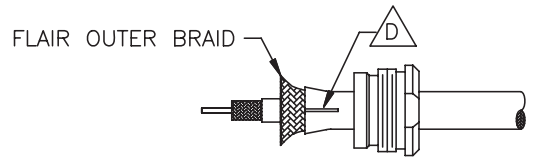


STRIPPING DIMENSIONS

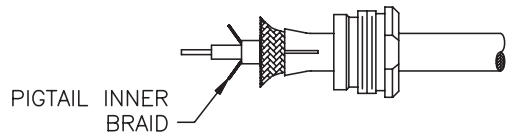
SCALE: 2/1

STEP #1

- A. PLACE CLAMP NUT ONTO CABLE.
- B. STRIP CABLE AS SHOWN.
- C. LIGHTLY TIN CENTER CONDUCTOR.



- D. FLARE OUTER BRAID TO ALLOW FREE ENTRY OF CONE, (.30 LONG LATERAL SLITS 180° APART MAY BE REQUIRED, FOR VERY INFLEXIBLE MATERIALS).



- E. TWIST INNER BRAID INTO TWO PIGTAILS 180° APART.

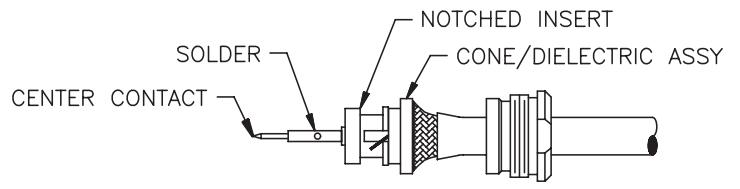


ALL MATERIALS MUST BE RoHS COMPLIANT.

SIZE	CAGE CODE	DWG NO.	REV.
A	0BDP7	907002	F

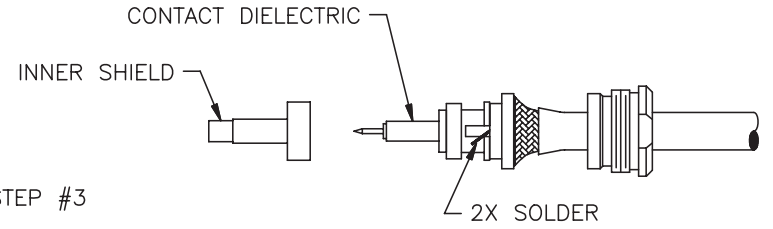
DO NOT SCALE DRAWING SCALE NONE WGT SHEET 2 OF 5

REVISIONS			
REV	DESCRIPTION	DATE	APPROVED
F	SEE SHT 1	-	-



STEP #2

- A. PUSH CONE/DIELECTRIC ASSY UNDER OUTER BRAID UNTIL BRAID IS FLUSH WITH EDGE OF CONE.
- B. INSTALL NOTCHED INSERT WITH PIGTAILS THRU SIDE SLOTS AND CENTER CONDUCTOR THRU CENTER HOLE UNTIL BOTTOMED AGAINST CONE/DIELECTRIC ASSY.
- C. POSITION CENTER CONTACT OVER CENTER CONDUCTOR UNTIL SEATED IN BORE OF NOTCHED INSERT AND SOLDER IN PLACE.



STEP #3

- A. PLACE CONTACT DIELECTRIC OVER CENTER CONTACT UNTIL BOTTOMED.
- B. WRAP PIGTAILS BETWEEN SHIELD RIDGES AND SOLDER, BEING CAREFUL NOT TO ALLOW PIGTAIL OR SOLDER TO EXTEND ABOVE SHIELD RIDGES.
- C. INSTALL INNER SHIELD\* OVER CONTACT DIELECTRIC AND NOTCHED INSERT UNTIL SEATED.

\*"INNER SHIELD" MAY BE INSIDE BODY ASSY

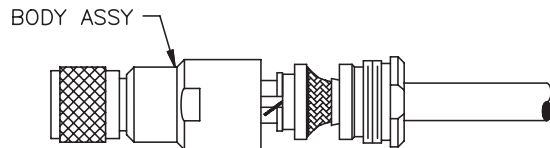


ALL MATERIALS MUST BE RoHS COMPLIANT.

SIZE	CAGE CODE	DWG NO.	REV.
A	0BDP7	907002	F

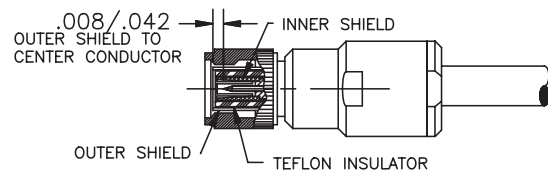
DO NOT SCALE DRAWING SCALE NONE WGT SHEET 3 OF 5

REVISIONS			
REV	DESCRIPTION	DATE	APPROVED
F	SEE SHT 1	—	—

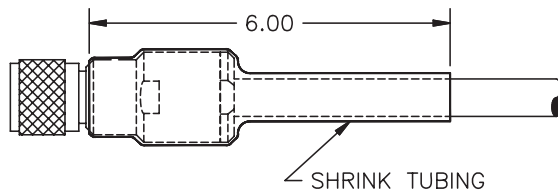


STEP #4

- A. BRING CLAMP NUT UP ONTO TAPERED PORTION OF CABLE.
- B. INSTALL BODY ASSY OVER ENTIRE ASSY AND ENGAGE WITH CLAMP NUT.



- C. TIGHTEN WITH WRENCH 30–40 IN. LB TORQUE.



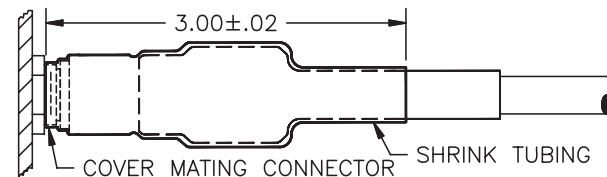
ALL MATERIALS MUST BE RoHS COMPLIANT.

SIZE	CAGE CODE	DWG NO.	REV.
A	OBDP7	907002	F
DO NOT SCALE DRAWING		SCALE NONE	WGT SHEET 4 OF 5

REVISIONS			
REV	DESCRIPTION	DATE	APPROVED
F	SEE SHT 1	—	—

STEP #5

- A. APPLY SHRINK TUBING, (ITEM 2) 6" LONG, AFTER CABLE IS ASSEMBLED (BOTH ENDS)



OUTDOOR APPLICATION ONLY

STEP #6

- A. APPLY SHRINK TUBING, (ITEM 2) 3" LONG, AFTER CABLE IS INSTALLED (BOTH ENDS)

NOTE: IF ADDING SHRINK TUBING IS NOT FEASIBLE, APPLY EQUIVALENT METHOD OF WATERTIGHT SEAL.



ALL MATERIALS MUST BE RoHS COMPLIANT.

SIZE	CAGE CODE	DWG NO.	REV.
A	OBDP7	907002	F
DO NOT SCALE DRAWING		SCALE NONE	WGT SHEET 5 OF 5

This page intentionally left blank.



# B Analog Color Bar Generator

## B.1 Appendix Overview

This appendix describes how to set up the optional Analog Color Bar Generator (CBG). The optional CBG is available in either NTSC or PAL versions.

The topics covered in this chapter are listed below.

Topic	Page
Description	B-1
Functions	B-1
Operating Modes	B-1
Configuration	B-2
Technical Background	B-2
Configuration	B-2
General	B-2
Entering Characters	B-4
Preliminary Setup Procedure	B-4
Configure Text Line A	B-8
Configure Text Line B	B-9
Configure Control Line	B-9
Check the Configuration	B-13
Configuration Reference	B-16
Button Functions	B-16
Full Character Set	B-17
Character Subsets	B-18
Delay Values	B-18

## B.2 Description

### B.2.1 Functions

The CBG provides the following functions:

- Inserts a color bar pattern conforming to SMPTE Engineering Guideline EG 1-1990 for SMPTE Color Bars
- Inserts test tones of 440 Hz and 1 kHz
- Lets you create and edit two lines of text that can be added to the color bar display, at locations you select
- Allows you to control when the color bars and tones are added to the transmitted signal and when to automatically place the MTX5000 IDU into the standby mode.

### B.2.2 Operating Modes

The CBG has four operating modes that are selected using the MTX5000 IDU color LCD display panel touch screen and/or function keys. The four operating modes are displayed on the color LCD display panel Color Bars screen and are identified as follows:

- **Off** - Color bars and audio test tones are turned off.
- **On** - Color bars and/or audio test tones are continuously on.
- **A Gen** (Auto Generated) - If a loss of video signal occurs, color bars and/or audio test tones are transmitted after a programmable delay.
- **A Stby** (Auto Standby) - If a loss of video signal occurs, the transmitter is automatically placed into standby (PA turned off).

## B.2.3 Configuration

Each of the four operating modes can be configured to meet your needs. Configuration is accomplished using four push button switches mounted on the CBG board. Configuration is normally performed only when the MTX5000 IDU is first installed, or if the CBG has been replaced by the factory.

Configuring the CBG will include specifying the following:

- If the CBG will generate audio tones, video color bars, or both
- What text will be displayed on screen whenever the color bars are displayed. There are two lines of text: Text Line A and Text Line B. Each line contains 16 character fields. Each character field can display any character in the full character set.
- Where each text line is displayed on the screen
- Which characters in a text line are visible on the default screen and which are hidden
- The foreground and background colors of the text lines
- The length of time (delay) the CBG will wait after loss of video signal before it begins generating tones and/or bars.

Configuration of the CBG consists of selecting the characters for each of the two lines of text and for a seven-character control line.

## B.2.4 Technical Background

The CBG includes circuits that provide both a video signal, and audio test tones of 1 kHz and 400 Hz on separate audio channels (1 kHz on Audio 1, 440 Hz on Audio 2).

Text lines and parameters are stored in memory and are controlled by a microprocessor. A video detection circuit notifies

the processor whenever a valid external video signal is present. Non-volatile memory preserves parameters and transmitter ID information. Once set, no battery or other power is required to save these parameters.

## B.3 Configuration

### B.3.1 General

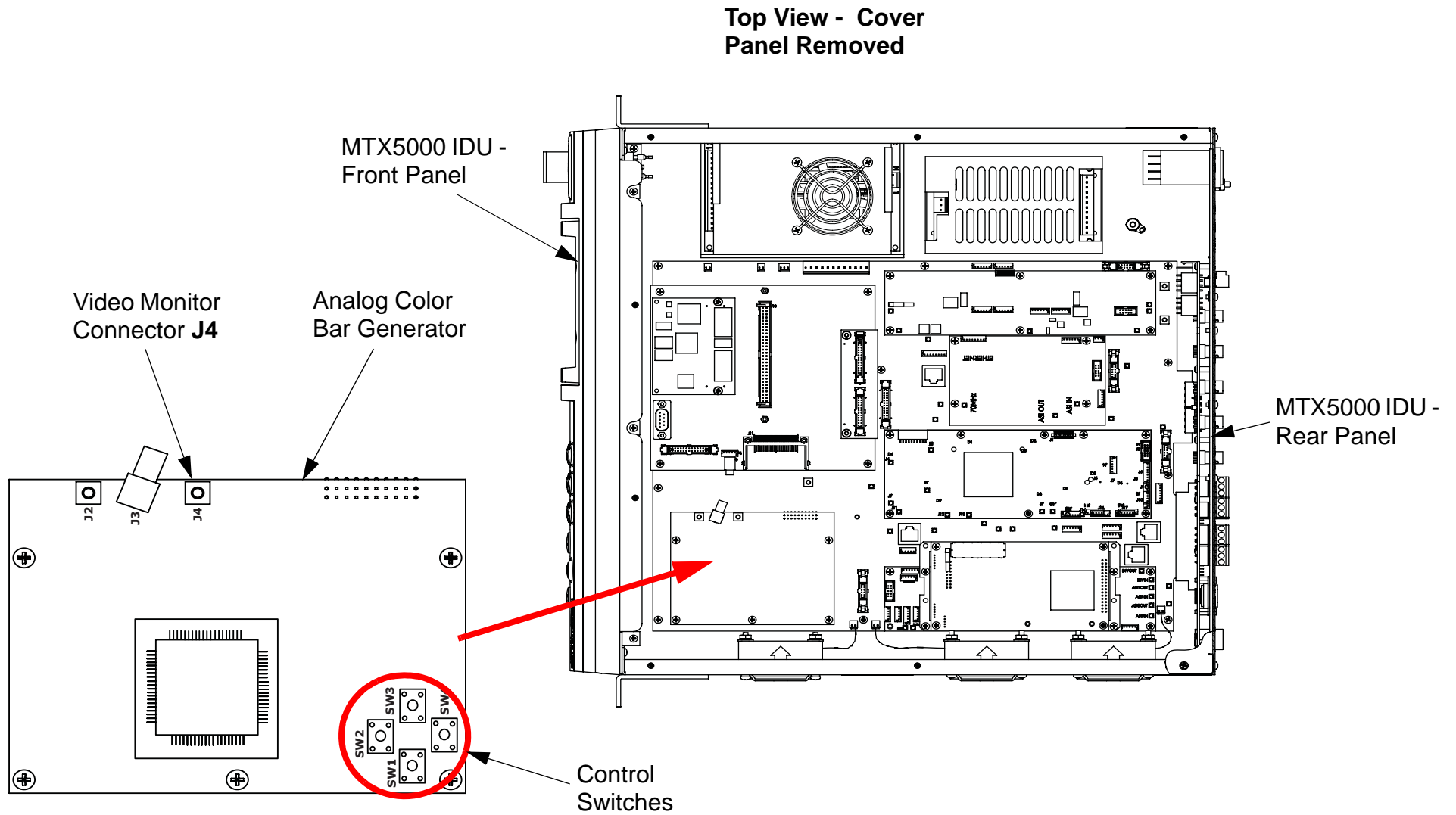
Configuration of the CBG involves using the MTX5000 IDU color LCD display panel touch screen or function keys, four control switches on the CBG board (See [Figure B-1 on page B-3](#)), and an external monitor to enter text for the text lines and the numerical parameters for the control line.

The MTX5000 IDU must be removed from its mounting rack (if installed). The top cover panel must then be removed to allow connection between the external monitor and the CBG and to allow access to the four control switches. Steps are provided in the following procedures to set all parameters in the CBG.

To avoid potential operator problems that could impact operation of the MTX5000 System, the IDU color LCD display panel **Color Bars** screen **Off** option must be selected when procedures contained in this Appendix are completed.

When performance of these procedures is complete, perform [“Select Color Bar Generator Mode” on page 3-52](#) to select the CGB operating mode required for Analog Preset operations.

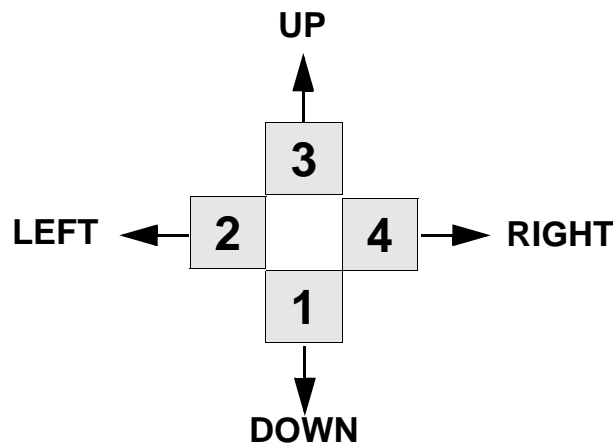
Figure B-1: MTX5000 IDU Analog Color Bar Generator



## B.3.2 Entering Characters

Entering characters utilizes the four CBG control switches in a similar way to the four arrow keys on a standard computer keyboard. See Figure B-2. In order to maximize your control using only four switches, each switch has multiple functions depending on whether the CBG is in character mode or subset mode.

Figure B-2: Button Functions



**Character Mode** In the character mode, scrolling up or down with switches **1** and **3** will change the highlighted character one character up or down in the full character set. See Table B-3 on page B-17.

**Subset Mode** To make editing the text lines faster, the full character set is divided into subsets. You can jump from one subset to the next instead of scrolling through the full character set one character at a time.

In subset mode, scrolling up or down with switches **1** and **3** will change the highlighted character one subset up or down within the list of subsets. See Table B-4 on page B-18.

**Hiding Characters** If you wish to hide any characters in the default display, press switches **1** and **3** simultaneously while the CBG is in subset mode. That character will show in inverse video and will be hidden from the default display. That character can still be viewed and changed in the editing mode. A black background is a hidden character; a white background is a character that is not hidden.

## B.3.3 Preliminary Setup Procedure

The procedure required to set up the optional Analog Color Bar Generator is contained in the following steps. This procedure must be performed prior to performing any or all of the following procedures.

- “Configure Text Line A” on page B-8
- “Configure Text Line B” on page B-9
- “Configure Control Line” on page B-10
- “Check the Configuration” on page B-13

---

### WARNING



There are electrical conditions of voltage and current in this equipment which can cause death or injury.

Use extreme care when performing this procedure.

---

---

**WARNING**

Remove all jewelry before beginning work on the equipment.

Jewelry can conduct electrical current. Accidental contact can result in electrocution or severe burns.

---

**WARNING**

Rotating equipment (cooling fans) is used in the operation of this equipment.

When performing this procedure, know the location of the rotating equipment.

---

**WARNING**

Remove all jewelry before beginning work on the equipment.

Jewelry can be caught in rotating equipment or on protruding parts, resulting in injury.

---

---

**CAUTION****Electrostatic Discharge (ESD)**

*The MTX5000 IDU and the CBG contain components that are sensitive to electrostatic discharge. Observe static precautions when configuring the CBG.*

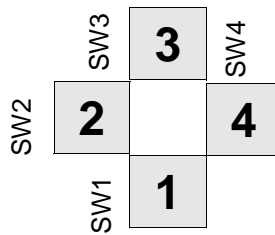
*Perform all work on a static free work surface. Use a conductive mat that is properly grounded or ensure the MTX5000 IDU is electrically connected to earth ground.*

*Use a grounded wrist strap, and ensure the strap makes good skin contact. The wrist strap must be electrically grounded to the bench or MTX5000 IDU chassis at all times.*

---

1. If you have not already done so, perform the following:
  - Power down the MTX5000 System. [See "Powering the MTX5000 System" on page 3-7.](#)
  - Disconnect all cables and remove the MTX5000 IDU from its rack (if already mounted).
2. Remove 8 screws from the top of the unit, remove 2 screws at the rear of the unit, and remove the MTX5000 IDU cover panel.
3. Position the MTX5000 IDU with its front panel to your left. This will orient the four control switches, as shown in [Figure B-3 on page B-6.](#)

**Figure B-3: Control Switch Locations**



4. Connect an AC power cable to the MTX5000 IDU rear panel AC **POWER IN** connector.
5. Connect the MTX5000 IDU power cable to AC power of the correct type and voltage.
6. Verify the power source is turned on.

**CAUTION** Exercise care to avoid damage to exposed circuitry in the MTX5000 IDU.

*When connecting test cables in the following steps, do not allow the test cable BNC connector and the BNC connector on the cable connected to the external monitor to come in contact with any circuit boards contained in the MTX5000 IDU.*

7. Connect the CBG test cable supplied with your MTX5000 IDU to the CBG video monitor connector **J4**. See [Figure B-1 on page B-3](#).
8. Connect a BNC cable between an external monitor and the CGB test cable BNC connector.
9. Verify the external monitor is powered up.

10. Raise the MTX5000 IDU power switch protective cover, press the power switch, observe the symbol on the power switch illuminates green, and close the protective cover.

---

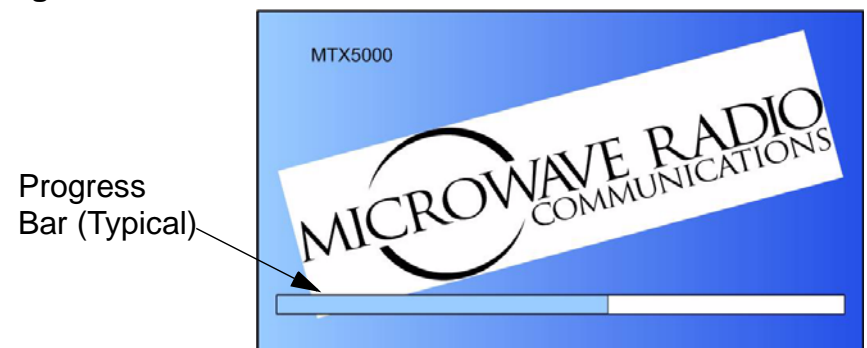
**Notes** When power is applied to the MTX5000 IDU, it will automatically enter the local mode of operation.

The MTX5000 will return to the last settings that were in use when the unit was powered down, but the unit will not resume transmitting if the unit was transmitting when it was powered down.

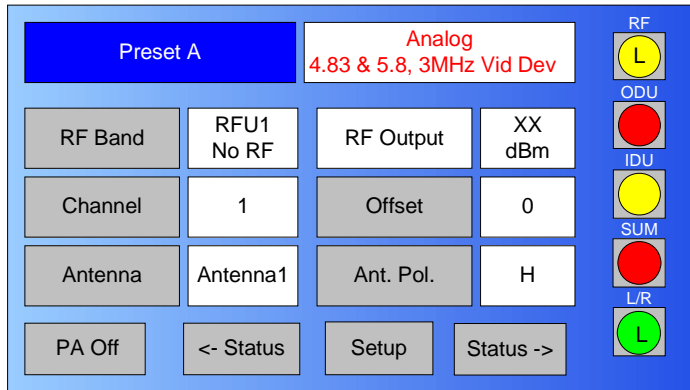
---

11. The normal power-up sequence is as follows:
  - After a short delay, the introduction screen will be displayed on the color LCD display panel. See [Figure B-4](#). A progress bar will also be displayed indicating power up progress.
  - When the power up sequence is complete, the Main screen will be displayed on the color LCD display panel. See [Figure B-5 on page B-7](#).

**Figure B-4: Introduction Screen**



**Figure B-5: Main Screen - Typical**



**CAUTION** Always wait a minimum of 5 seconds after the Main screen is displayed following power up before selecting a Preset.

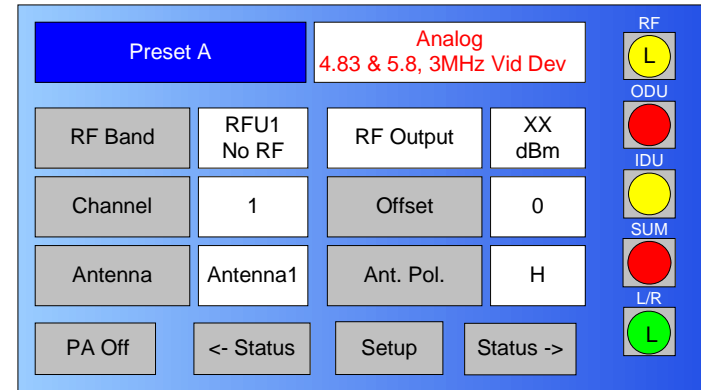
**Note** In order to set up the analog CBG, an analog Preset must be selected in the following step. Any analog Preset may be selected.

12. Select any analog Preset per "Select Preset" on page 3-24.

**Note** When performing steps at the MTX5000 IDU in the following steps, option buttons may be selected using either the touch screen or the function keys and the **SEL** key.

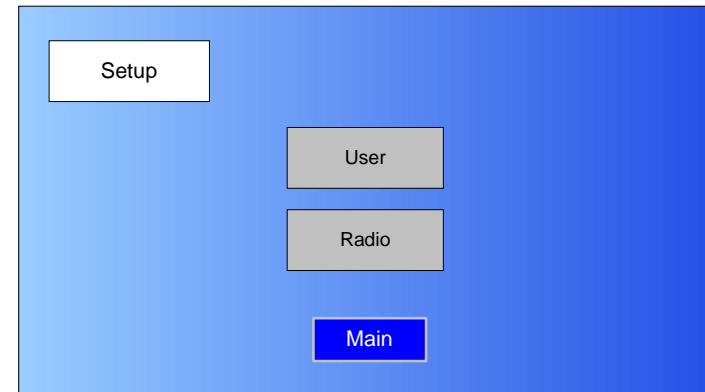
13. Observe the Main screen is displayed. See Figure B-6.

**Figure B-6: Main Screen - Typical**



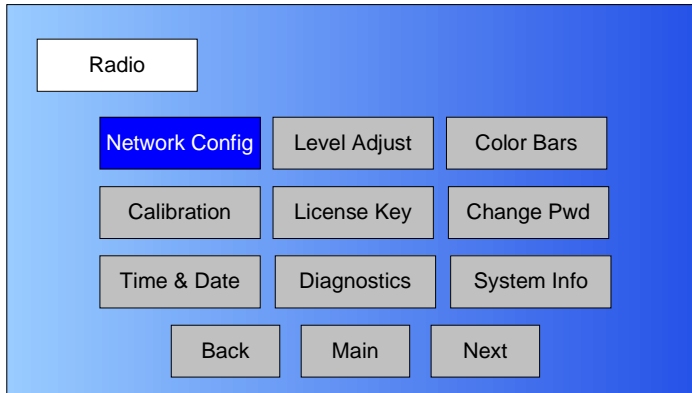
14. Select the **Setup** option button and observe the **Setup** screen is displayed. See Figure B-7.

**Figure B-7: Setup Screen**



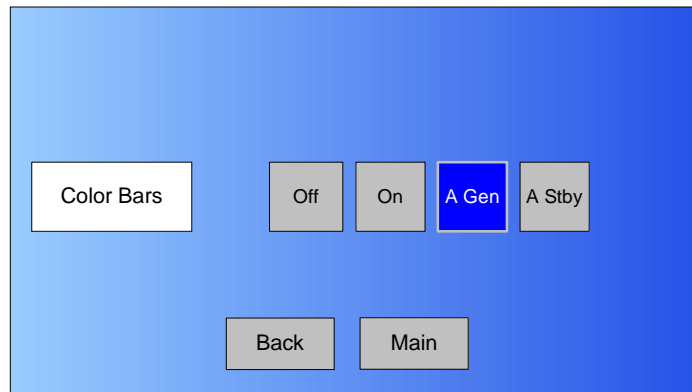
15. Select the **Radio** option button and observe the **Radio** screen is displayed. See Figure B-8 on page B-8.

**Figure B-8: Radio Screen**



16. Select the **Color Bars** option button and observe the **Color Bars** screen is displayed. See Figure B-9.

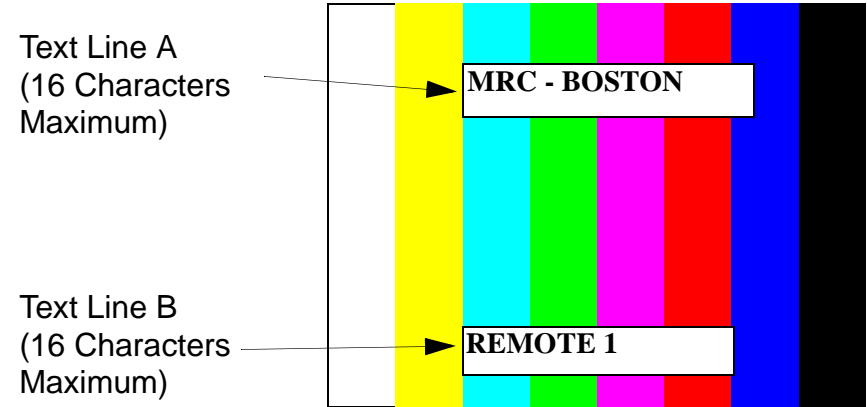
**Figure B-9: Color Bars Screen**



17. Select the **On** option button and observe the external monitor display.
  - The video display should now have color bars similar to Figure B-10. The text lines will contain different characters than those shown, and may be in different positions on the screen.

- The Color Bar Generator default screen shown in Figure B-10 will be displayed when the Color Bar Generator is active (**On**).

**Figure B-10: Color Bar Generator Default Screen**



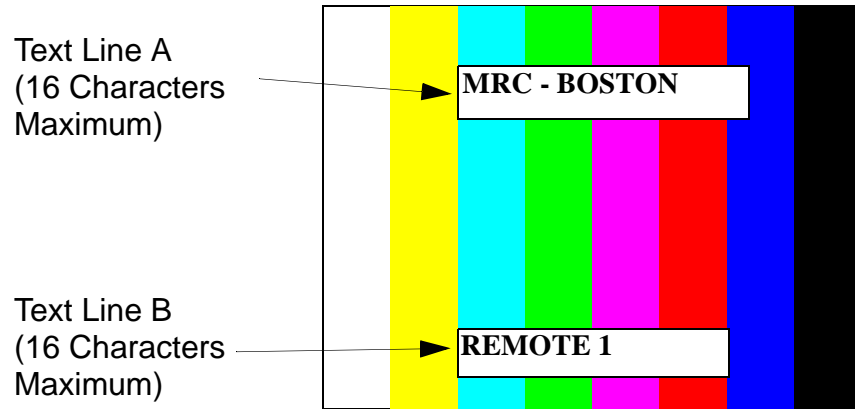
### B.3.4 Configure Text Line A

The procedure required to configure Text Line A of the color bar generator display is contained in the following steps.

1. Verify the "Preliminary Setup Procedure" on page B-4 has been performed.
2. Verify the Color Bar Generator default screen is displayed. See Figure B-11 on page B-9.

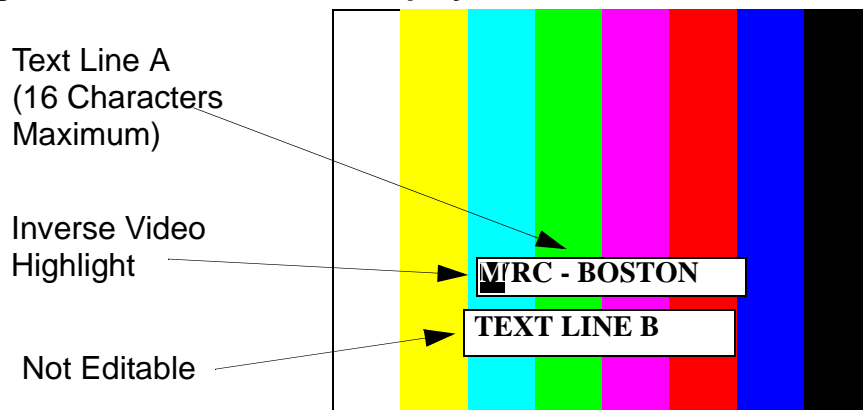


**Figure B-11: Color Bar Generator Default Screen**



3. Press control switches **2** and **3** simultaneously for approximately 5 seconds.
  - The video display should now look like [Figure B-12](#).
  - The cursor will be positioned at the first character field of Text Line A. The first character field will be highlighted in inverse video.
  - Note that the second line (**TEXT LINE B**) is for editing reference only and cannot be changed.

**Figure B-12: Text Line A Display**



4. The Color Bar Generator will now be in the Subset Mode. To use the Character Mode, go to [step 6](#).
5. To move up or down in the list of subsets, press control switches **1** or **3** until you reach the desired subset. See [Table B-4](#) on [page B-18](#).

---

<b>Note</b>	Perform <a href="#">step 6</a> thru <a href="#">step 8</a> for each character field you wish to change.
-------------	---

---

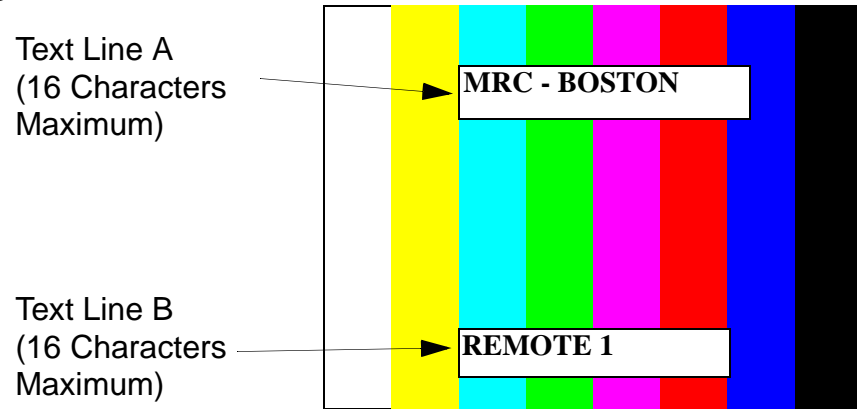
6. Press control switch **4** to enter the Character Mode.
7. Press control switches **1** or **3** to scroll up or down in the full character set until you reach the desired character. See [Table B-3](#) on [page B-17](#).
8. Press control switch **4** to move to the next character field. The next character field will be highlighted in inverse video.
9. When all of Text Line A is correct, press any 3 control switches simultaneously to save Text Line A into memory.
10. Observe the screen flashes briefly as Text Line A is stored. This is normal.

### **B.3.5 Configure Text Line B**

The procedure required to configure Text Line B of the color bar generator display is contained in the following steps.

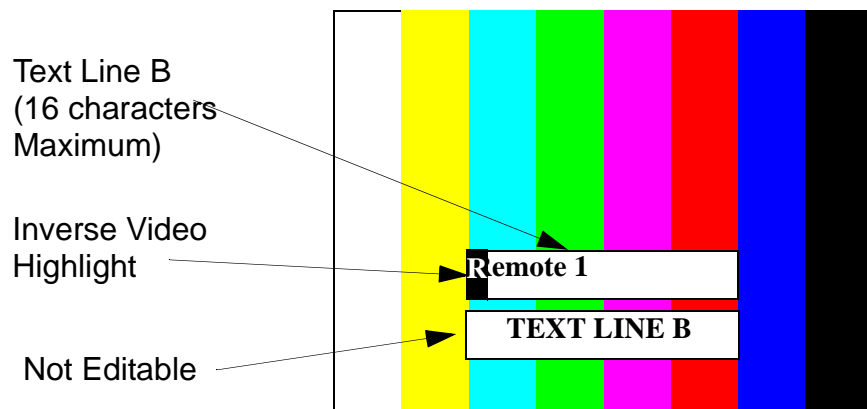
1. Verify the [“Preliminary Setup Procedure”](#) on [page B-4](#) has been performed.
2. Verify the Color Bar Generator default screen is displayed. See [Figure B-13](#) on [page B-10](#).

**Figure B-13: Color Bar Generator Default Screen**



3. Press control switches **3** and **4** simultaneously for approximately 5 seconds.
  - The video display should now look like [Figure B-14](#).
  - The cursor will be positioned at the first character field of Text Line B. The first character field will be highlighted in inverse video.
  - Note that the second line (**TEXT LINE B**) is for editing reference only and cannot be changed.

**Figure B-14: Text Line B Display**



4. The Color Bar Generator will now be in the Subset Mode. To use Character Mode go to [step 6](#).
5. To jump up or down in the list of subsets, press control switches **1** or **3** until the you reach the desired subset. See [Table B-4 on page B-18](#).

---

<b>Note</b>	Perform <a href="#">step 6</a> thru <a href="#">step 8</a> for each character field you wish to change.
-------------	---

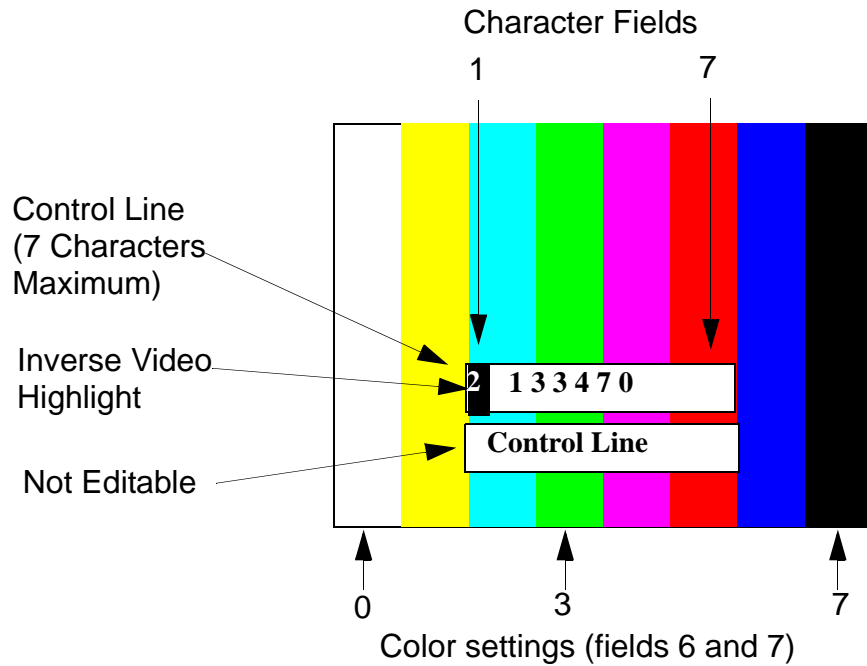
---

6. Press control switch **4** to enter Character Mode.
7. Press control switches **1** or **3** to scroll up or down in the full character set until you reach the desired character. See [Table B-3 on page B-17](#).
8. Press control switch **4** to move to the next character field. The next character field will be highlighted in inverse video.
9. When all of Text Line B is correct, press any 3 control switches simultaneously to save Text Line B into memory.
10. Observe the screen flashes briefly as Text Line A is stored. This is normal.

### B.3.6 Configure Control Line

The Control Line contains seven character fields. Each character field controls a particular aspect of the Color Bar Generator's operation. Each character field can have a value of **0** through **7** only. Alphabetic characters and character subsets are not used. See [Figure B-15 on page B-11](#) and [Table B-1 on page B-11](#).

**Figure B-15: Control Line Display**



**Table B-1: Control Line Parameters**

Character Field	Function
1 2	When CBG is set to <b>A GEN</b> or <b>A Stby</b> , sets the delay before the CBG will generate bars/tones (Auto Generated) or places the MTX5000 IDU into standby (Auto Standby). Delays can be set from 1 to 32 seconds. See <a href="#">Table B-5 on page B-18</a> for delay values.
3	Sets whether the CBG will generate bars, tones, or both. 0 = no tones, no bars 1 = tones, no bars 2 = no tones, bars 3 = tones and bars
4	Sets the position of Text Line A on the screen. Each increment in value moves the text line down a small amount. 0 = top of screen 7 = bottom of screen  NOTE - If the position values for Text Line A and Text Line B are the same, Line A and Line B are in the same location. In this case only Line A will be visible.

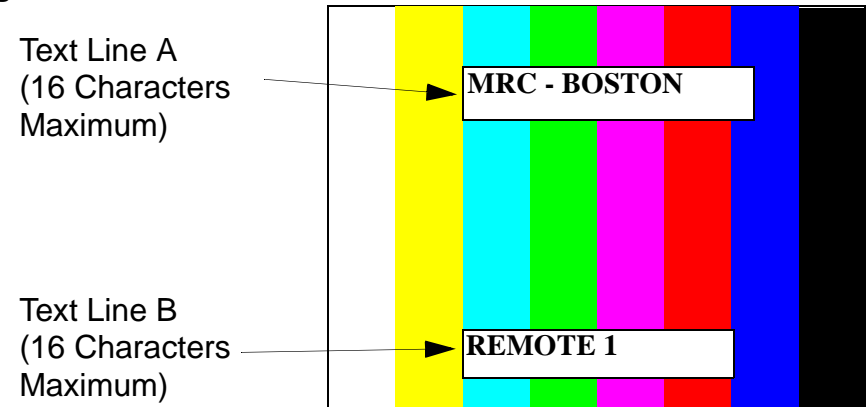
**Table B-1: Control Line Parameters**

5	<p>Sets the position of Text Line B on the screen. Each increment in value moves the text line down a small amount.</p> <p>0 = top of screen 7 = bottom of screen</p> <p>NOTE - If the position values for Text Line A and Text Line B are the same, Line A and Line B are in the same location. In this case only Line A will be visible.</p>
6	<p>Sets the foreground color of both text lines.</p> <p>0 = white 7 = black</p> <p>See <a href="#">Figure B-15 on page B-11</a> for which value sets which color.</p>
7	<p>Sets the foreground color of both text lines.</p> <p>0 = white 7 = black</p> <p>See <a href="#">Figure B-15 on page B-11</a> for which value sets which color.</p>

The procedure required to configure the Color Bar Generator display control line is contained in the following steps.

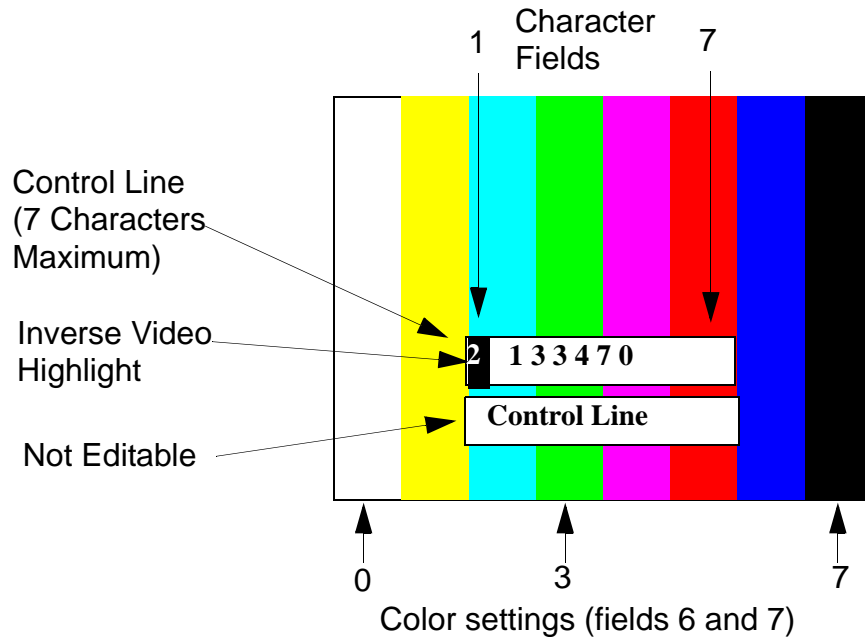
1. Verify the [“Preliminary Setup Procedure” on page B-4](#) has been performed.
2. Verify the Color Bar Generator default screen is displayed. See [Figure B-16](#).

**Figure B-16: Color Bar Generator Default Screen**



3. Press control switches **2** and **4** simultaneously.
4. The video display should now look like [Figure B-17 on page B-13](#).  
The cursor will be positioned at the first character field of the Control Line.
  - The first character field will be highlighted in inverse video.
  - Note that the second line Control Line is for editing reference only and cannot be changed.

**Figure B-17: Control Line Display**



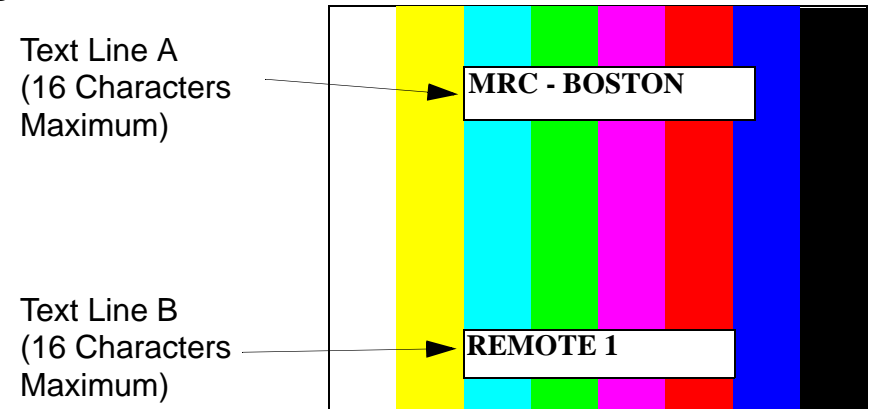
### B.3.7 Check the Configuration

When all the characters and parameters have been entered, check to be sure the Color Bar Generator is operating the way you want it to. Perform this check before you install the MTX5000 IDU in its rack.

#### Check Text Lines

1. Verify the "Preliminary Setup Procedure" on page B-4 has been performed.
2. Verify the Color Bar Generator default screen is displayed. See Figure B-18.

**Figure B-18: Color Bar Generator Default Screen**

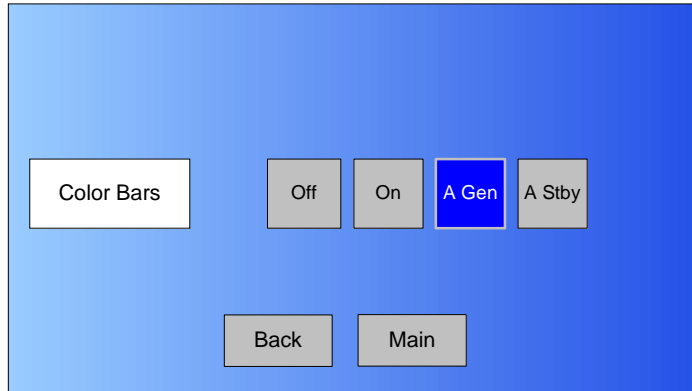


3. Verify the **Color Bars** screen is displayed on the MTX5000 IDU color LCD display panel and verify the **Color Bars** screen **On** option button is selected. See Figure B-19 on page B-14.

**Note** Repeat [step 5](#) and [step 6](#) for each character field you wish to change.

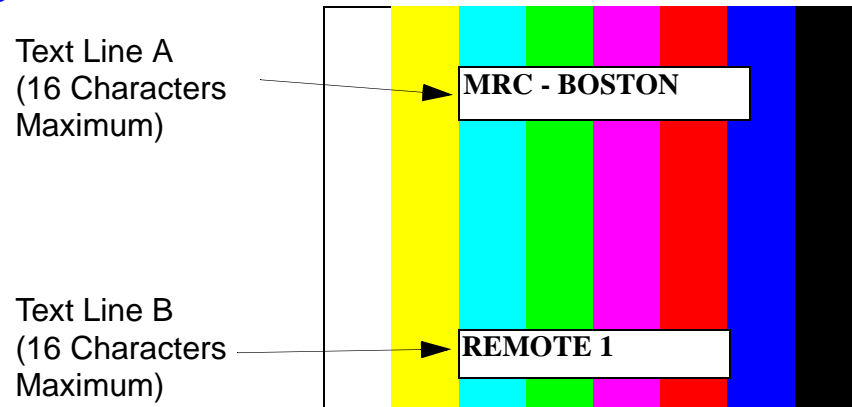
5. Press control switches **1** or **3** to scroll up or down through numbers 0 through 7 until you reach the desired number.
6. Press control switch **4** to move to the next character field. The next character field will be highlighted in inverse video.
7. When the Control Line is correct, press any 3 control switches simultaneously to save the Control Line into memory.
8. Observe the screen flashes briefly as Text Line A is stored. This is normal.

**Figure B-19: Color Bars Screen**



4. The video display should display color bars similar to [Figure B-20](#). The text lines should be displayed where you intended, and should contain the characters you entered.

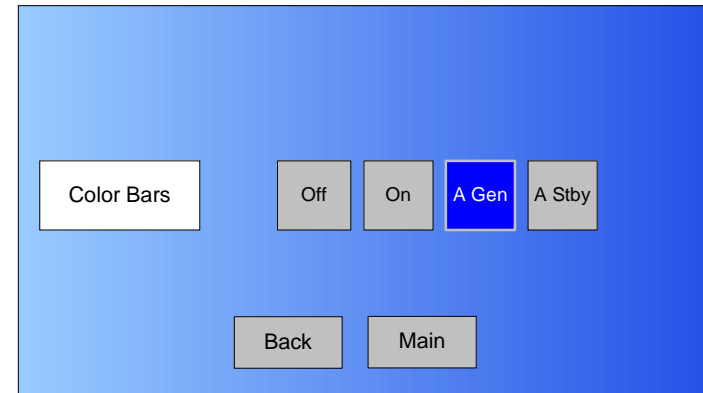
**Figure B-20: Color Bar Generator Default Screen**



**Check Auto Generate**

1. Select the MTX5000 IDU color LCD display panel **A Gen** option using the touch screen or the function keys. [See Figure B-21](#).

**Figure B-21: Color Bars Screen**



2. Apply a video input to the MTX5000 IDU. If **A Gen** is correctly configured, the color bars and text lines should disappear from the video display.
3. Disconnect the video input while watching the video monitor. After the **A Gen** delay you configured, the bars and text should appear.

**Check Auto Standby**

1. Connect external antennas or RF dummy loads to the MTX5000 IDU **RFU 1** and **RFU 2** output connectors.

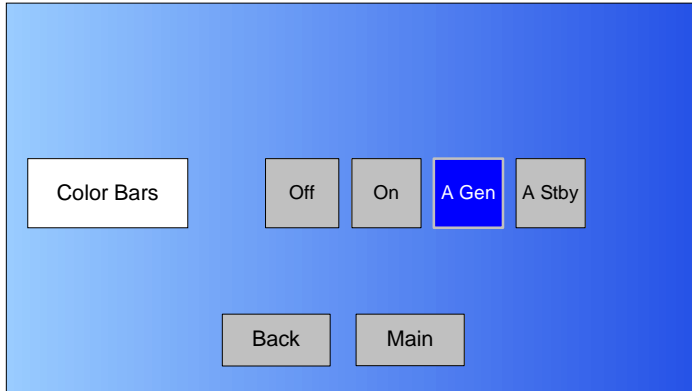
---

**Note** When performing the following steps at the MTX5000 IDU color LCD display panel, option buttons may be selected using either the touch screen or the function keys and the **SEL** key.

---

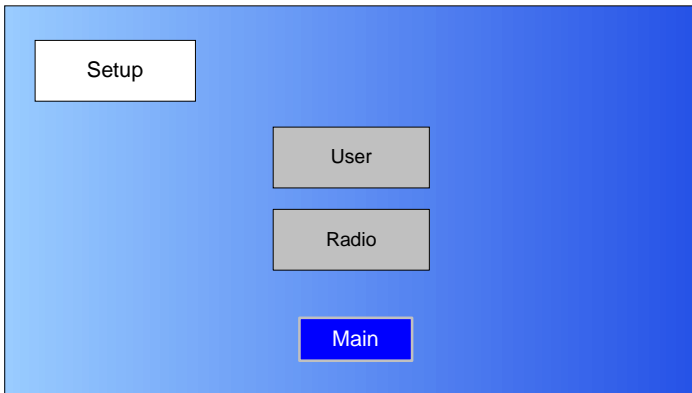
2. Select the MTX5000 IDU color LCD display panel **Color Bars** screen **A Stby** option button. [See Figure B-22 on page B-15](#).

**Figure B-22: Color Bars Screen**



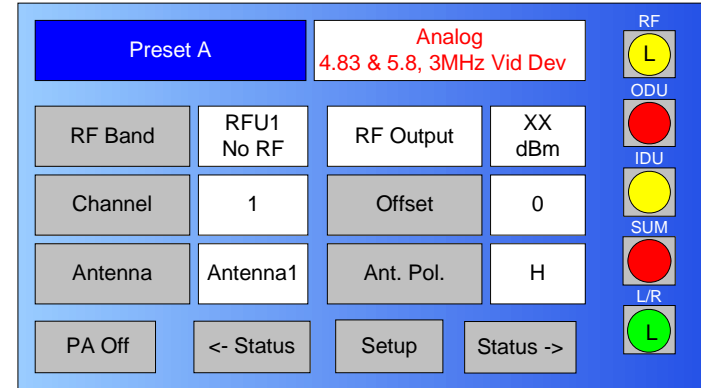
3. Select the **Color Bars** screen **BACK** option button and observe the **Setup** screen is displayed. See [Figure B-23](#).

**Figure B-23: Setup Screen**



4. Select the **Setup** screen **Back** option button and observe the Main page is displayed. See [Figure B-24](#).
5. Apply a video input to the MTX5000 IDU. If **A Stby** is correctly configured, the color bars and text lines should disappear from the video display.

**Figure B-24: Main Screen - Typical**



6. Select the **PA** operation button and observe the status indicator changes to green.
7. Disconnect the video input from the MTX5000 IDU.
8. The **PA** status indicator should now change to inactive (grey).
9. Perform "[Select Color Bar Generator Mode](#)" on [page 3-52](#) to select the CGB operating mode required for Analog Preset operations.
10. Power down the MTX5000 System. See "[Powering the MTX5000 System](#)" on [page 3-7](#).
11. Disconnect the external antennas or RF dummy loads from the **RFU 1** and **RFU 2** connectors.
12. Disconnect the BNC cable from the external monitor and the test cable and disconnect the test cable from the CBG video monitor connector **J4**.
13. Set the power source to off and disconnect the AC power cable from the MTX5000 IDU rear panel **AC POWER IN** connector.
14. Install the MTX5000 IDU cover panel and secure with 8 screws on the top of the unit and 2 screws at the rear of the unit.

- Connect all cables and install the MTX5000 IDU in its mounting rack. See "Installation" on page 6-1.

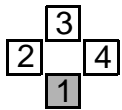
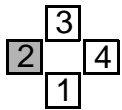
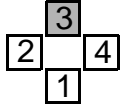
## B.4 Configuration Reference

The following tables provide additional configuration information, including button functions, character sets, and delay values.

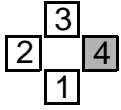
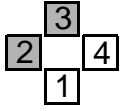
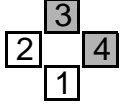
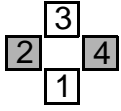
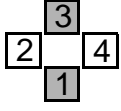
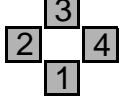
### B.4.1 Button Functions

Table B-2 provides details of how the buttons on the Color Bar Generator board work:

**Table B-2: CBG Button Functions**

Switch #	Switch Location	Function	First Press	Second press
<b>Single Button Functions</b>				
1		Scroll down	Scroll down one character or character subset	
2		Cursor left	Switches to character mode	moves cursor to next character field to left
3		Scroll up	Scroll up one character or character subset	

**Table B-2: CBG Button Functions (Continued)**

Switch #	Switch Location	Function	First Press	Second press
4		Cursor right	Switches to character mode	Moves cursor to next character field to right
<b>Two Button Functions</b>				
SW2 & SW3				Moves cursor to first character in Text Line A
SW3 & SW4				Moves cursor to first character in Text Line B
SW2 & SW4				Moves cursor to first character in Control Line
SW1 & SW3				Hides/unhides characters. CBG must be in subset mode first.
<b>Three Key Functions</b>				
Press any 3 keys				Saves the current configuration to memory. Video flashes briefly when configuration is stored.



## B.4.2 Full Character Set

Table B-3 contains all of the characters the Color Bar Generator can display. .

**Table B-3: Full Character Set**

Character	Subset #	Note
	0	space
<b>A</b>	1	
<b>B</b>	2	
<b>C</b>	3	
<b>D</b>	4	
<b>E</b>	5	
<b>F</b>	6	
<b>G</b>	7	
<b>H</b>	0	
<b>I</b>	1	
<b>J</b>	2	
<b>K</b>	3	
<b>L</b>	4	
<b>M</b>	5	
<b>N</b>	6	
<b>O</b>	7	
<b>P</b>	0	
<b>Q</b>	1	
<b>R</b>	2	
<b>S</b>	3	
<b>T</b>	4	
<b>U</b>	5	
<b>V</b>	6	
<b>W</b>	7	
<b>X</b>	0	

**Table B-3: Full Character Set (Continued)**

Character	Subset #	Note
<b>Y</b>	1	
<b>Z</b>	2	
<b>!</b>	3	exclamation
<b>.</b>	4	period
<b>,</b>	5	comma
<b>=</b>	6	equals
<b>^</b>	7	caret
<b>(</b>	0	left parenthesis
<b>)</b>	1	right parenthesis
<b>-</b>	2	hyphen
<b>_</b>	3	underline
<b>+</b>	4	plus
<b>&lt;</b>	5	less than
<b>&gt;</b>	6	greater than
<b> </b>	7	vertical bar
<b>/</b>	0	forward slash
<b>'</b>	1	apostrophe
<b>\</b>	2	back slash
<b>:</b>	3	colon
<b>;</b>	4	semicolon
<b>■</b>	5	half height bullet
<b>■</b>	6	full height bullet
<b>■</b>	7	solid block
<b>ø</b>	0	space
<b>1</b>	1	
<b>2</b>	2	
<b>3</b>	3	

**Table B-3: Full Character Set (Continued)**

Character	Subset #	Note
4	4	
5	5	
6	6	
7	7	
8	0	
9	1	
∇	2	T above a V
#	3	number
\$	4	dollars
%	5	percent
&	6	ampersand (and)
*	7	asterisk

**B.4.3 Character Subsets**

Table B-4 provides the character subsets the Color Bar Generator uses. Note: the subsets are also shown in Table B-3 on page B-17.

**Table B-4: Character Subsets**

Subset #	Character
0	(space), H, P, X, ([, /, ø, 8
1	A, I, Q, Y, (, [, 1, 9
2	B, J, R, Z, \, 2, ∇
3	C, K, S, !, _, [:, 3, #
4	D, L, T, [., _ [, 4, \$
5	E, M, U, [., +, ■, 5, %

6	F, N, V, =, <, ■, 6, &
7	G, O, W, ^,  , ■, 7, *

**B.4.4 Delay Values**

Table B-5 provides the delay in seconds corresponding to each value in Control Line fields 1 and 2. Note that the delay values repeat themselves so that a setting of 4,0 results in the same delay as a setting of 0,0 (1 second).

**Table B-5: Delay Values**

Field Position 1	Field Position 2	Delay in Seconds
0	0	1
0	1	2
0	2	3
0	3	4
0	4	5
0	5	6
0	6	7
0	7	8
1	0	9
1	1	10
1	2	11
1	3	12
1	4	13
1	5	14
1	6	15
1	7	16

**Table B-5: Delay Values (Continued)**

Field Position 1	Field Position 2	Delay in Seconds
2	0	17
2	1	18
2	2	19
2	3	20
2	4	21
2	5	22
2	6	23
2	7	24
3	0	25
3	1	26
3	2	27
3	3	28
3	4	29
3	5	30
3	6	31
3	7	32
4	0	1
4	1	2
4	2	3
4	3	4
4	4	5
4	5	6
4	6	7
4	7	8
5	0	9
5	1	10

**Table B-5: Delay Values (Continued)**

Field Position 1	Field Position 2	Delay in Seconds
5	2	11
5	3	12
5	4	13
5	5	14
5	6	15
5	7	16
6	0	17
6	1	18
6	2	19
6	3	20
6	4	21
6	5	22
6	6	23
6	7	24
7	0	25
7	1	26
7	2	27
7	3	28
7	4	29
7	5	30
7	6	31
7	7	32

This page intentionally left blank.

# Index

## A

About This Manual	Notices-i
AC power	
MTX5000 IDU	2-7
AC power cable	6-4
advanced features	8-2
Advanced Operations	5-1
Advanced operations	
add licensed options	5-117
configuring your MTX5000 IDU	5-3
create a new custom analog Preset	5-7, 5-73
create a new custom digital ASI Preset	5-82
create a new custom digital COFDM Preset	5-77
create a new custom digital COFDM Preset configuration	5-17
create a new custom digital DVB-S Preset	5-91
create a new custom digital DVB-S Preset configuration	5-47
create a new custom digital IP Preset	5-96
create a new custom digital LMS-T Preset	5-86
default password	5-4
Firmware updates	5-114
license manager	5-117
load custom Preset configuration settings from file	5-106
local mode password control	5-4
password control	5-1
restore custom Presets to factory defaults	5-102
save current Preset configuration settings to a file	5-104
set network addresses for remote operation	5-109
Software updates	
factory licensed options	5-117

memory stick	5-102, 5-114
thumb drive	5-102, 5-114
USB flash drive	5-114
System Rules	5-2
update an existing analog Preset configuration	5-73
update an existing digital ASI Preset configuration	5-82
update an existing digital COFDM Preset configuration	5-17, 5-77
update an existing digital DVB-S Preset configuration	5-47, 5-91
update an existing digital IP Preset configuration	5-96
update an existing digital LMS-T Preset configuration	5-86
update an existing Preset configuration	5-7
analog CBG	
Text lines and parameters	B-2
Analog Color Bar Generator	B-1
Audio Connections	6-24

## C

Cabling	
mobile installations	6-3
CAUTIONS	Notices-iv
Character Set, CBG	B-17
Character Subsets, CBG	B-18
Color Bar Generator	
Button Functions	B-16
Character Subsets	B-18
Check AUTOGEN	B-14
Check AUTOSTDBY	B-14
Check Text Lines	B-13
Check the Configuration	B-13
Configuration	B-2
Character Mode	B-4
character mode	B-4

Control Line	B-10
Entering Characters	B-4
Hiding Characters	B-4
Setup	B-4
Text Line A	B-8
Text Line B	B-9
Configuration Reference	B-16
Button Functions	B-16
Character Subsets	B-18
Full Character Set	B-17
Configure Text Line A	B-8
Configure Text Line B	B-9
Configure the Control Line	B-10
control switches	B-4
Delay Values	B-18
Full Character Set	B-17
Functions	B-1
functions	B-1
hide characters	B-4
Operating Modes	B-1
operating modes	B-1
subset mode	B-4
Technical Background	B-2
Composite Video (CV)	8-2
Connections	
IDU Rear Panel	6-19
Control Line	B-10
Conventions	Notices-iv
Copyright	Notices-i
<b>D</b>	
Damage in Shipment	6-2
default password	5-4
Documents	
Ordering	1-1

## E

E-mail	
Feedback	1-2
Technical Support team	1-2

## F

factory default analog Presets	5-7, 5-74
factory default digital ASI Presets	5-82
factory default digital COFDM Presets	5-77
factory default digital DVB-S Presets	5-91
factory default digital IP Presets	5-96
factory default digital LMS-T Presets	5-86
factory default Presets	5-3
Feedback	1-2

## G

Grounding	6-5
-----------	-----

## H

How to Use This Manual	1-2
------------------------	-----

## I

Installation	6-1
AES/EBU connections	6-24
AUDIO 1 thru AUDIO 4 connections	6-24
Cabling	6-3, 6-4
Checks before power-up	6-27
connections to the IDU	6-16
define wiring harness	6-5
Defining the Wiring Harness	
Determine the Size of Harness Required	6-9
Equipment Rack	6-2
Ethernet	6-27
function cables	6-7
grounding	6-5

Initial power-up	6-27
mobile applications	6-2
Moisture	6-3
moisture	6-3
mount ODU	6-13
mounting one ODU	6-14
Mounting the MRX4000	6-3
optional Remote Access Subnotebook PC	6-26
pinouts of AES/EBU channel 1 and 2 digital connectors	6-25
pinouts of AUDIO 1 thru 4 analog connectors	6-25
remote control option	6-26
RF and DC power cabling	6-5
RFU POWER OUT connector pinouts	6-26
RJ-45 crossover cable	6-26
Site Preparation	6-2
Triax connectors	6-6, A-1
Ventilation	6-3
ventilation	6-3
Installing the MRX4000	6-2
<b>L</b>	
license manager	5-117
licensed options	5-117
<b>M</b>	
Mast Top Connections	6-16
Mounting the MTX5000 IDU	6-3
Mounting the ODU	6-14
MRC Customer Service	1-1, 6-2
Business Hours	1-1
Telephone	1-1
MRC Technical Support	
Business Hours	1-1
E-mail	1-1
Telephone	1-1

MTX5000	
components and capabilities	2-1
configurations	2-1
Menu Screens	3-10
<b>O</b>	
ODU	
Mounting	6-14
On-Line Viewing	Notices-v
ordering a license key from MRC	5-118
<b>P</b>	
passwords	5-4
personal password	5-4
Power Connections	6-4
Additional Powering Notes	6-4
Power Requirements	6-4
IDU Power Consumption	6-4
ODU Power Consumption (Dual ODU System)	6-4
Standard ODU Power Consumption	6-4
Supply Voltage	6-4
power requirements	6-4
Preparing for Operation	3-7
Proprietary Material	Notices-i
<b>Q</b>	
Quality Certification	Notices-i
<b>R</b>	
Radio IP, Subnet Mask, Gateway, and DNS Server addresses	5-109
Replacement Parts	7-1
External Cables	7-1
<b>S</b>	
SD Serialized Digital Interface video	8-2
site power requirements	6-4

Site preparation .....	6-14
Symbols Used .....	Notices-v
<b>T</b>	
Technical Support .....	1-1
Text Line A .....	B-8
Text Line B .....	B-9
Theory of Operation .....	8-1
analog FM transmission .....	8-1
Digital Video Broadcasting - Terrestrial (DVB-T) .....	8-1
encoding SD and HD video .....	8-2
Frequency-Shift Keying (FSK) modem .....	8-1
IDU and the ODU .....	8-1
Modulation Error Ratio/Error Vector Magnitude (MER/ EVM) .....	8-1
MRX4000 internal software .....	8-3
MTX5000 ODU .....	8-5
MTX5000 system architecture .....	8-1
MTX5000 user interface .....	8-2
ODU functional block diagram .....	8-5

ODU output .....	8-3
remote operation .....	8-2
RF transmission .....	8-1
user interface .....	8-1
Troubleshooting .....	4-1
<b>U</b>	
Unpacking .....	6-1
update firmware .....	5-114
<b>W</b>	
WARNINGS .....	Notices-iv
Warranty statement .....	6-29
Waste Electrical and Electronic Equipment .....	Notices-v
Wayside Data	
Compatibility .....	6-24
What This Manual Covers .....	1-2
Wiring Harness	
Determine Size .....	6-9