



Engineering and Testing for EMC and Safety Compliance



Accredited under NVLAP Lab Code 200061-0

### Certification Application Report FCC Part 15.247 & Industry Canada RSS-210

<b>Test Lab:</b> Rhein Tech Laboratories, Inc. Tel: 703-689-0368 360 Herndon Parkway Fax: 703-689-2056 Suite 1400 Herndon, VA 20170 E-Mail: atcbinfo@rheintech.com Web: http://www.rheintech.com		<b>Applicant:</b> Fleetwood Group, Inc. Tel: (616) 820-8271 P.O. Box 1259 Fax: (616) 820-8300 Holland, MI 49422 Contact: Will Buehler Email: <a href="mailto:WillB@fleetwoodgroup.com">WillB@fleetwoodgroup.com</a>	
<b>FCC ID/ IC ID:</b>	FBRWRS960X/ 1859A-WRS960X	<b>Test Report Date:</b>	June 15, 2007
<b>Platform:</b>	N/A	<b>RTL Work Order #:</b>	2007182
<b>Model Name/ Model Number:</b>	WRS960X	<b>RTL Quote #:</b>	QRTL07-158
<b>American National Standard Institute:</b>	ANSI C63.4-2003: Methods of Measurement of Radio-Noise Emissions from Low-Voltage Electrical and Electronic Equipment in the Range of 9 kHz to 40 GHz		
<b>FCC Classification:</b>	DSS – Part 15 Spread Spectrum Transmitter		
<b>FCC Rule Part(s)/Guidance:</b>	FCC Rules Part 15.247: Operation within the bands 920-928 MHz, 2400-2483.5 MHz and 5725-5850 MHz Direct Sequence System October 1, 2006, DA 00-705		
<b>Industry Canada:</b>	RSS-210 Issue 7: Low Power License-Exempt Communications Devices		
<b>Digital Interface Information</b>	Digital Interface was found to be compliant		
<b>Frequency Range (MHz)</b>	<b>Output Power (W)</b>	<b>Frequency Tolerance</b>	<b>Emission Designator</b>
2401 – 2475	0.0002*	N/A	930KFXD

\* power is peak conducted

I, the undersigned, hereby declare that the equipment tested and referenced in this report conforms to the identified standard(s) as described in this test report. No modifications were made to the equipment during testing in order to achieve compliance with these standards. Furthermore, there was no deviation from, additions to, or exclusions from, the applicable parts of FCC Part 2, FCC Part 15 and ANSI C63.4.

Signature: 

Date: June 15, 2007

Typed/Printed Name: Desmond A. Fraser

Position: President

*This report may not be reproduced, except in full, without the written approval of Rhein Tech Laboratories, Inc.  
The test results relate only to the item(s) tested.*

## Table of Contents

---

1	General Information .....	5
1.1	Scope .....	5
1.2	Description of EUT .....	5
1.3	Test Facility .....	5
1.4	Related Submittal(s)/Grant(s) .....	5
1.5	Modifications .....	5
2	Test Information .....	6
2.1	Description of Test Modes .....	6
2.2	Exercising the EUT .....	6
2.3	Test Result Summary .....	6
2.4	Test System Details .....	7
2.5	Configuration of Tested System .....	8
3	Duty Cycle Calculation - FCC §15.35(c), RSS-Gen 4.3 .....	8
4	Peak Output Power - §15.247(b)(1); RSS-GEN .....	9
4.1	Power Output Test Procedure .....	9
4.2	Power Output Test Data .....	9
5	Compliance with the Band Edge – FCC §15.247(d); RSS-GEN .....	10
5.1	Band Edge Test Procedure .....	10
5.2	Band Edge Test Results .....	10
5.2.1	Calculation of Lower Band Edge .....	10
5.2.2	Conducted Lower Band Edge Plots .....	11
5.2.3	Calculation of Upper Band Edge .....	13
5.2.4	Conducted Upper Band Edge Plots .....	13
6	Antenna Conducted Spurious Emissions - §15.247(d); RSS-Gen .....	15
6.1	Antenna Conducted Spurious Emissions Test Procedures .....	15
6.2	Antenna Conducted Spurious Emissions Test Results .....	15
7	20 dB Bandwidth – FCC §15.247(a)(1); IC RSS-Gen .....	17
7.1	20 dB Bandwidth Test Procedure .....	17
7.2	20 dB Modulated Bandwidth Test Data .....	17
7.3	20 dB Bandwidth Plots .....	18
8	Carrier Frequency Separation - §15.247(a)(1) .....	21
8.1	Carrier Frequency Separation Test Procedure .....	21
8.2	Carrier Frequency Separation Test Data .....	21
8.3	Hopping Characteristics Test Procedure .....	22
8.4	Number of Hopping Frequencies .....	22
8.5	Average Time of Occupancy .....	23
9	Radiated Emissions - §15.209; RSS-210 §6.2.1 .....	25
9.1	Limits of Radiated Emissions Measurement .....	25
9.2	Radiated Emissions Measurement Test Procedure .....	25
9.3	Radiated Emissions Test Results .....	27
9.3.1	Radiated Emissions Digital/Receiver Test Data .....	27
9.3.2	Radiated Emissions Harmonics/Spurious Test Data .....	27
10	Conclusion .....	29

---

### Figure Index

---

Figure 2-1:	Configuration of System Under Test.....	8
-------------	---	---

---

### Table Index

---

Table 2-1:	Channels Tested.....	6
Table 2-2:	Test Result Summary – FCC Part 15, Subpart C (Section 15.247) .....	6
Table 2-3:	Equipment Under Test.....	7
Table 4-1:	Power Output Test Equipment.....	9
Table 4-2:	Power Output Test Data .....	9
Table 5-1:	Band Edge Test Equipment.....	10
Table 6-1:	Antenna Conducted Spurious Emissions Test Equipment.....	15
Table 6-2:	Antenna Conducted Spurious Emissions (2401 MHz = -6.8 dBm).....	15
Table 6-3:	Antenna Conducted Spurious Emissions (2437 MHz = -8.7 dBm).....	15
Table 6-4:	Antenna Conducted Spurious Emissions (2475 MHz = -8.1 dBm).....	16
Table 7-1:	20 dB Bandwidth Test Equipment.....	17
Table 7-2:	20 dB Modulated Bandwidth Test Data.....	17
Table 8-1:	Carrier Frequency Separation Test Equipment.....	21
Table 8-2:	Time of Occupancy Test Equipment .....	23
Table 9-1:	Radiated Emissions Test Equipment .....	26
Table 9-2:	Digital/Receiver Radiated Emissions Test Data.....	27
Table 9-3:	Radiated Emissions Harmonics/Spurious 2401 MHz.....	27
Table 9-4:	Radiated Emissions Harmonics/Spurious 2437 MHz.....	28
Table 9-5:	Radiated Emissions Harmonics/Spurious 2475 MHz.....	28
Table 9-6:	Radiated Emissions Harmonics/Spurious Hopping Mode.....	29

---

### Plot Index

---

Plot 5-1:	Conducted Lower Band Edge – Fixed Low Channel Operation .....	11
Plot 5-2:	Conducted Lower Band Edge – Hopping .....	12
Plot 5-3:	Conducted Upper Band Edge – Fixed High Channel Operation .....	13
Plot 5-4:	Conducted Upper Band Edge – Hopping .....	14
Plot 7-1:	20 dB Bandwidth Channel 1 .....	18
Plot 7-2:	20 dB Bandwidth Channel 37.....	19
Plot 7-3:	20 dB Bandwidth Channel 75.....	20
Plot 8-1:	Carrier Frequency Separation .....	21
Plot 8-2:	Number of Hopping Frequencies.....	22
Plot 8-3:	Time of Occupancy (Dwell Time) .....	23
Plot 8-4:	Time of Occupancy (Dwell Time 30 Second Sweep) .....	24

---

### Appendix Index

---

Appendix A:	FCC Part 1.1307, 1.1310, 2.1091, 2.1093; IC RSS-Gen: RF Exposure .....	30
Appendix B:	Agency Authorization Letter.....	31
Appendix C:	Confidentiality Request Letter.....	32
Appendix D:	IC Letters .....	33
Appendix E:	Label and Label Location .....	34
Appendix F:	Technical Operational Description.....	35
Appendix G:	Schematics.....	36
Appendix H:	Block Diagram .....	37
Appendix I:	Manual .....	38
Appendix J:	Test Photographs .....	39
Appendix K:	External Photographs .....	41
Appendix L:	Internal Photographs .....	45

---

### Photograph Index

---

Photograph 1:	ID Label Sample.....	34
Photograph 2:	ID Label Location .....	34
Photograph 3:	Radiated Testing – Front View .....	39
Photograph 4:	Radiated Testing – Back View .....	40
Photograph 5:	Top of Case.....	41
Photograph 6:	Bottom of Case .....	42
Photograph 7:	Side Face Top.....	43
Photograph 8:	Side Face Bottom.....	43
Photograph 9:	Side Face Right.....	44
Photograph 10:	Side Face Left.....	44
Photograph 11:	Top of PCB.....	45
Photograph 12:	Bottom of PCB .....	46

## 1 General Information

### 1.1 Scope

This is an original certification application request.

Applicable Standards:

- FCC Rules Part 15.247: Frequency Hopping, Direct Spread Spectrum and Hybrid Systems that are in operation within the bands of 902-928 MHz, 2400-2483.5 MHz and 5725-5850 MHz.
- Industry Canada RSS-210: Low Power License-Exempt Communications Devices

### 1.2 Description of EUT

<b>Equipment Under Test</b>	Base Station
<b>Model Name/Number</b>	WRS960X
<b>Power Supply</b>	Battery - 3 AA batteries (4.5 VDC)
<b>Modulation Type</b>	FHSS
<b>Frequency Range</b>	2401 – 2475 MHz
<b>Antenna Connector Type</b>	PCB F type
<b>Antenna Types</b>	Internal

### 1.3 Test Facility

The open area test site and conducted measurement facility used to collect the radiated data is located at 360 Herndon Parkway, Suite 1400, Herndon, Virginia 20170. This site has been fully described in a report and approved by the Federal Communications Commission to perform AC line conducted and radiated emissions testing (ANSI C63.4-2003).

### 1.4 Related Submittal(s)/Grant(s)

This is an original application for Fleetwood Group, Inc., Model Name: WRS960X, FCC ID: FBRWRS960X, IC: 1859A-WRS960X.

### 1.5 Modifications

To pass radiated spurious emissions, C18 and C19 were replaced with 1.2 pF capacitors, and C17 was inverted from its existing pad 180° to ground and connected to the pad located between C15 and L2/C18.

## 2 Test Information

### 2.1 Description of Test Modes

In accordance with FCC 15.31(m), and because the EUT utilizes an operating band greater than 10 MHz, the following frequencies were tested:

**Table 2-1: Channels Tested**

Channel	Frequency
Low	2401
Middle	2437
High	2475

### 2.2 Exercising the EUT

The EUT was supplied with test firmware programmed with a high, mid, and low channel for testing, as well as in an original configuration for hopping mode. The EUT was tested in all three orthogonal planes in order to determine worst-case emissions. The EUT was provided with software to continuously transmit during testing. The carrier was also checked to verify that information was being transmitted. There were no deviations from the test standard(s) and/or methods. The test results reported relate only to the item tested.

### 2.3 Test Result Summary

**Table 2-2: Test Result Summary – FCC Part 15, Subpart C (Section 15.247)**

Standard	Test	Pass/Fail or N/A
FCC 15.207	AC Power Conducted Emissions	N/A
FCC 15.209	Radiated Emissions	Pass
FCC 15.247(b)	Maximum Peak Power Output	Pass
FCC 15.247(d)	Antenna Conducted Spurious Emissions	Pass
FCC 15.247(d)	Band Edge Measurement	Pass
FCC 15.247(a)(1)	Carrier Frequency Separation	Pass
FCC 15.247(a)(1)(ii)	20 dB Bandwidth	Pass
FCC 15.247(a)(1)(iii)	Hopping Characteristics	Pass
FCC 15.247(a)(1)(iii)	Average Time of Occupancy	Pass

## 2.4 Test System Details

The test samples were received on June 7 and 14, 2007. The FCC identifiers for all applicable equipment, plus descriptions of all cables used in the tested system, are identified in the following table.

**Table 2-3: Equipment Under Test**

Part	Manufacturer	Model	Serial Number	FCC ID	Cable Description	RTL Bar Code
Radio	Fleetwood Group Inc.	WRS960X	N/A	FBRWRS960X	N/A	17953
Radio	Fleetwood Group Inc.	WRS960X	1	FBRWRS960X	N/A	17944
Radio	Fleetwood Group Inc.	WRS960X	3	FBRWRS960X	N/A	17942
Video Cable	Fleetwood Group Inc.	N/A	N/A	N/A	.03 m Unshielded Video	17948

## 2.5 Configuration of Tested System

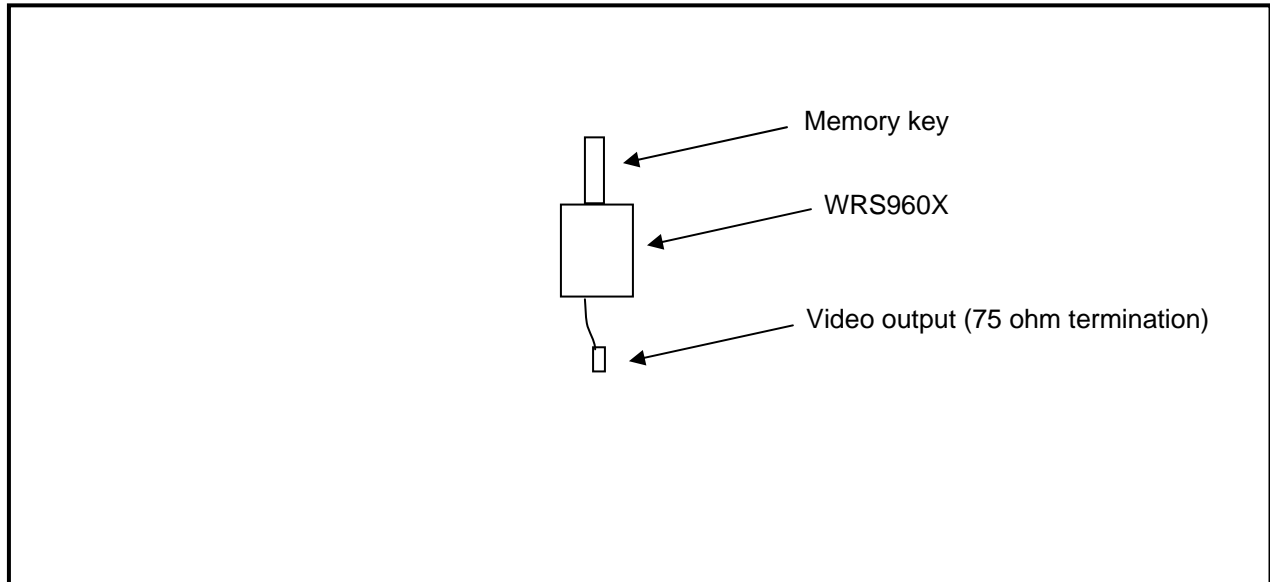

**Figure 2-1: Configuration of System Under Test**

### 3 Duty Cycle Calculation - FCC §15.35(c), RSS-Gen 4.3

A standard transmission consists of a 1.05 ms data packet, followed by a 292.5 ms blanking interval for a total transmission period of 293.55 ms. Therefore, the aggregate on time within a transmission period of 100 ms is 1.05 ms, or  $20\text{Log}(1.05/100) = 39.5\text{dB}$  or 20 dB, which is the maximum allowed.

The duty cycle correction is 20 dB.



#### 4 Peak Output Power - §15.247(b)(1); RSS-GEN

##### 4.1 Power Output Test Procedure

A conducted power measurement of the EUT was taken using an Agilent 4416A EPM-P Series Power Meter with an E9323A Peak and Average Power Sensor.

**Table 4-1: Power Output Test Equipment**

RTL Asset #	Manufacturer	Model	Part Type	Serial Number	Calibration Due Date
901356	Agilent Technologies	E9323A	Power Sensor	31764-264	10/03/07
901184	Agilent Technologies	E4416A	EPM-P Power Meter, single channel	GB41050573	10/03/07

##### 4.2 Power Output Test Data

**Table 4-2: Power Output Test Data**

Channel	Frequency (MHz)	Peak Power Conducted Output (dBm)
Low	2401	-6.8
Middle	2437	-8.7
High	2475	-8.1

##### Test Personnel:

Daniel W. Baltzell  
 Test Engineer

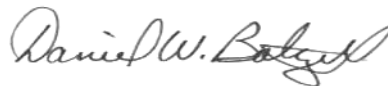

Signature

June 15, 2007  
 Date Of Test

## 5 Compliance with the Band Edge – FCC §15.247(d); RSS-GEN

### 5.1 Band Edge Test Procedure

The transmitter output was connected to its appropriate antenna. A conducted antenna port delta measurement was performed from the highest peak in the restricted band to the peak of the fundamental, and subtracted from the radiated field strength; the result was compared to the limit.

**Table 5-1: Band Edge Test Equipment**

RTL Asset #	Manufacturer	Model	Part Type	Serial Number	Calibration Due Date
900878	Rhein Tech Labs	AM3-1197-0005	3 meter Antenna Mast, polarizing	Outdoor Range 1	Not Required
901425	Insulated Wire, Inc.	KPS-1503-2400-KPS	RF cable, 20'	NA	12/05/07
901424	Insulated Wire Inc.	KPS-1503-360-KPS	RF cable 36"	NA	12/05/07
901242	Rhein Tech Labs	WRT-000-0003	Wood Rotating Table	N/A	Not Required
900814	Electro-Metrics	EM-6961 (RGA-60)	Double Ridged Guide Antenna (1 - 18 GHz)	2310	03/30/09
N/A	Hewlett Packard	8563E	Spectrum Analyzer	02816	09/06/07
900913	Hewlett Packard	85462A	EMI Receiver RF Section (9 KHz – 6.5 GHz)	3325A00159	03/21/08

### 5.2 Band Edge Test Results

#### 5.2.1 Calculation of Lower Band Edge

78.3 dBuV/m is the field strength measurement, from which the delta measurement of 41.6 dB is subtracted, resulting in a level of 36.7 dB. This level has a margin of 17.3 dB below the limit of 54 dBuV/m.

Calculation:  $78.3 \text{ dBuV/m} - 41.6 \text{ dB} - 54 \text{ dBuV/m} = -17.3 \text{ dB}$

Peak Field Strength of Lower Band Edge (100 kHz RBW/300 kHz VBW) = 98.3 dBuV/m

Quasi-Peak Field Strength of Lower Band Edge (120 kHz RBW/300 kHz VBW) = 78.3 dBuV/m

Delta measurement = 41.6 dB

### 5.2.2 Conducted Lower Band Edge Plots

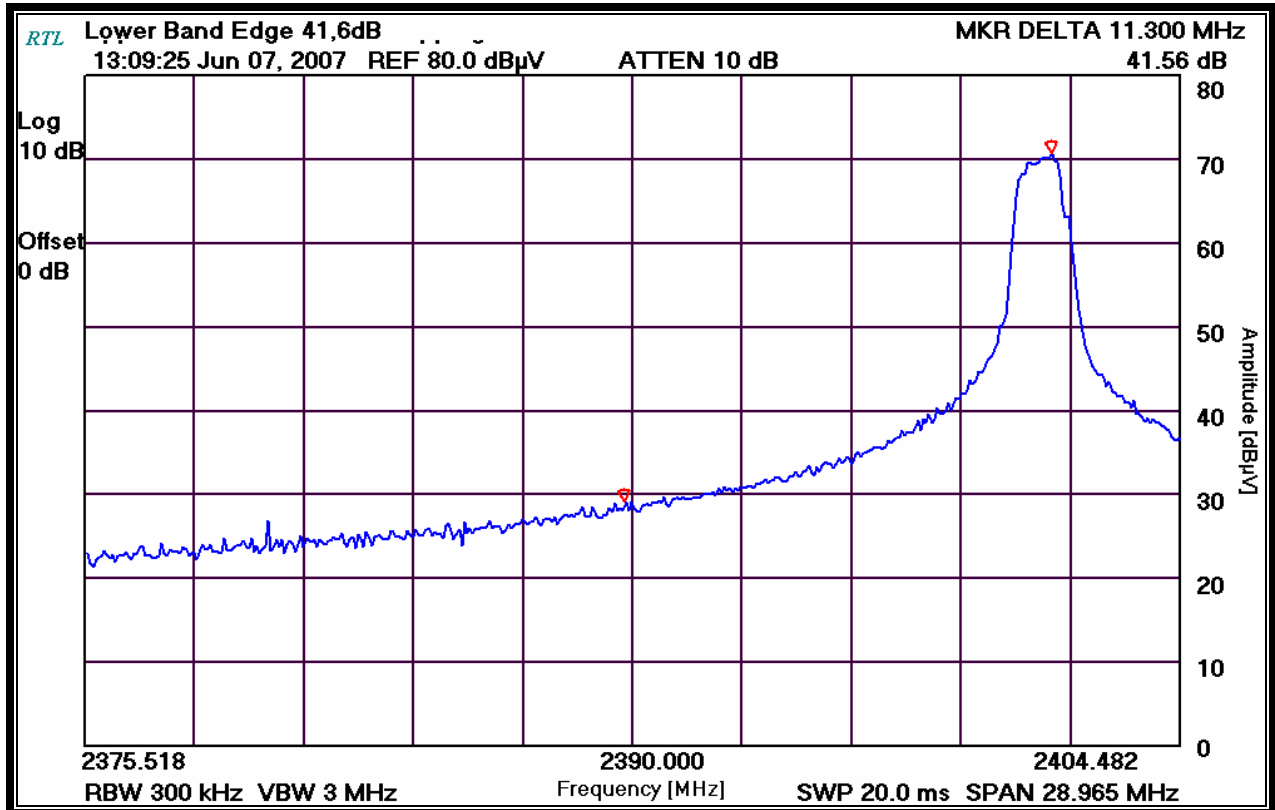

Plot 5-1: Conducted Lower Band Edge – Fixed Low Channel Operation

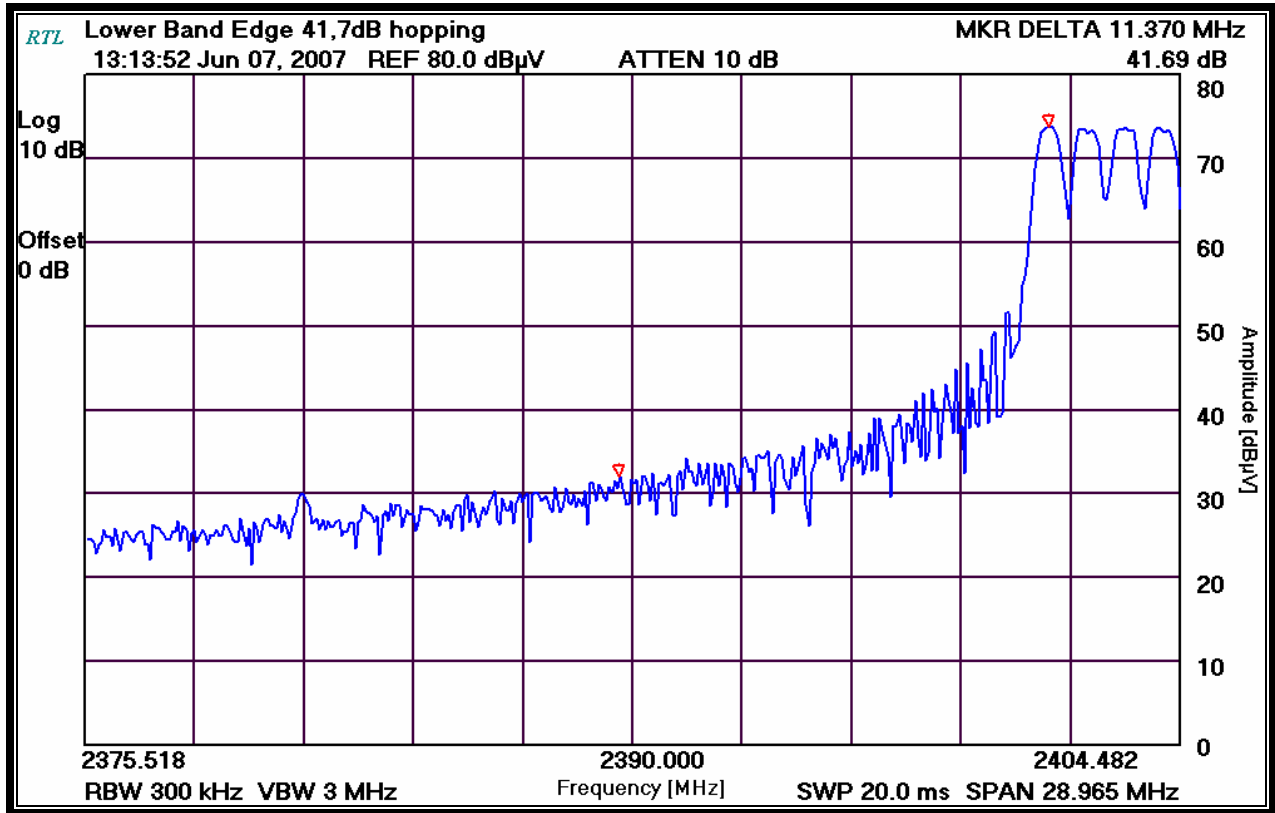

Plot 5-2: Conducted Lower Band Edge – Hopping

### 5.2.3 Calculation of Upper Band Edge

76.4 dBuV/m is the field strength measurement, from which the delta measurement of 40.9 dB is subtracted (reference hopping plot), resulting in a level of 35.5 dB. This level has a margin of 18.5 dB below the limit of 54 dBuV/m.

Calculation:  $76.4 \text{ dBuV/m} - 40.9 \text{ dB} - 54 \text{ dBuV/m} = -18.5 \text{ dB}$

Peak Field Strength of Upper Band Edge (1 MHz RBW/1 MHz VBW) = 96.4 dBuV/m  
 Average Field Strength of Upper Band Edge (1 MHz RBW/10 Hz VBW) = 76.4 dBuV/m  
 Delta measurement = 40.9 dB

### 5.2.4 Conducted Upper Band Edge Plots

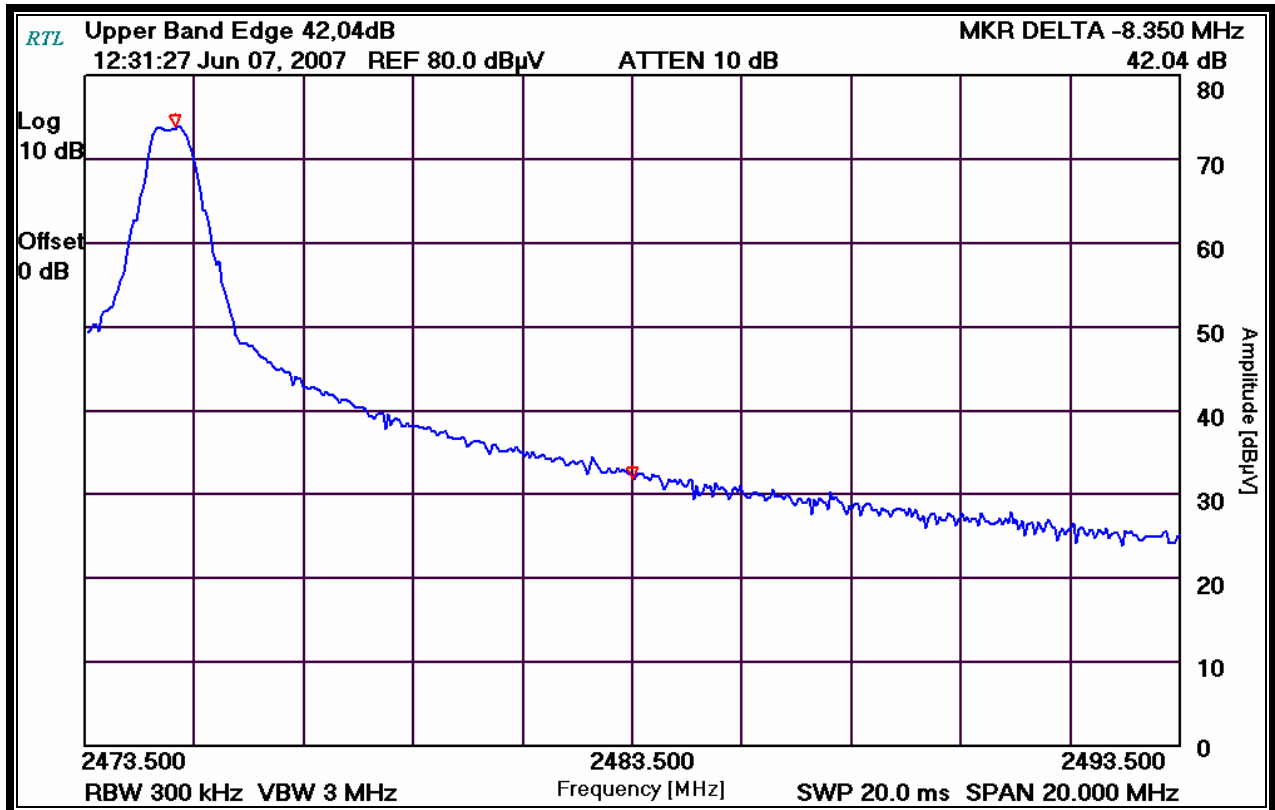

Plot 5-3: Conducted Upper Band Edge – Fixed High Channel Operation

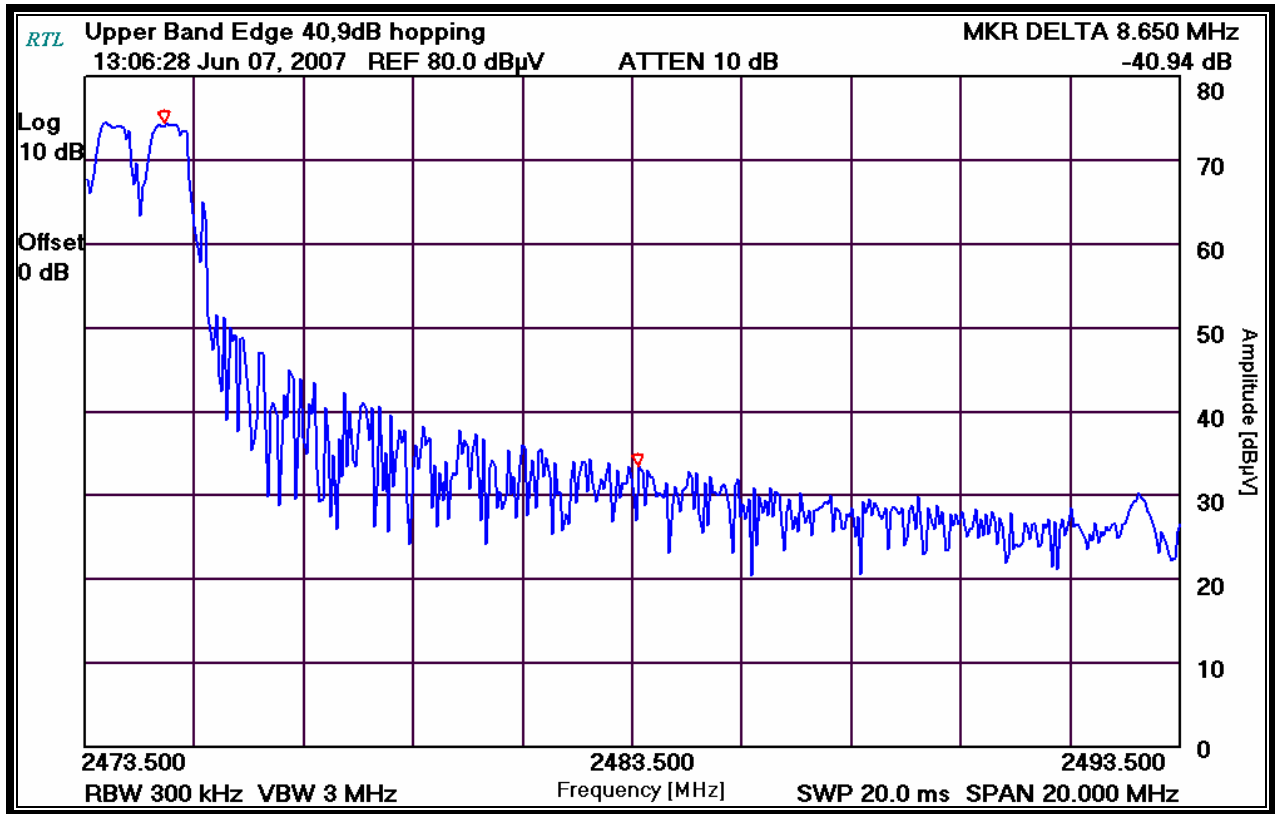

Plot 5-4: Conducted Upper Band Edge – Hopping

Test Personnel:

Daniel W. Baltzell  
 Test Engineer

Signature

June 7, 2007  
 Date Of Test

## 6 Antenna Conducted Spurious Emissions - §15.247(d); RSS-Gen

### 6.1 Antenna Conducted Spurious Emissions Test Procedures

Antenna conducted spurious emissions per FCC 15.247(c) were measured from the EUT antenna port using a 50 ohm spectrum analyzer with the resolution bandwidth set at 100 kHz, and the video bandwidth set at 1 MHz. The modulated carrier was identified at the following frequencies: 2401 MHz, 2437 MHz and 2475 MHz.

**Table 6-1: Antenna Conducted Spurious Emissions Test Equipment**

RTL Asset #	Manufacturer	Model	Part Type	Serial Number	Calibration Due Date
N/A	Hewlett Packard	8563E	Spectrum Analyzer	02816	09/06/07

### 6.2 Antenna Conducted Spurious Emissions Test Results

**Table 6-2: Antenna Conducted Spurious Emissions (2401 MHz = -6.8 dBm)**

Frequency (MHz)	Level (dBm)	Limit (dBm)	Margin (dB)	Result
4802.0	-46.2	-26.8	-19.4	Pass
7203.0	-33.3	-26.8	-6.5	Pass
9604.0	-50.3	-26.8	-23.5	Pass
12005.0	-62.0	-26.8	-35.2	Pass
14406.0	-69.2	-26.8	-42.4	Pass
16807.0	-70.2	-26.8	-43.4	Pass
19208.0	-70.3	-26.8	-43.5	Pass
21609.0	-71.8	-26.8	-45.0	Pass
24010.0	-72.5	-26.8	-45.7	Pass

**Table 6-3: Antenna Conducted Spurious Emissions (2437 MHz = -8.7 dBm)**

Frequency (MHz)	Level (dBm)	Limit (dBm)	Margin (dB)	Result
4874.0	-40.3	-28.7	-11.6	Pass
7311.0	-31.0	-28.7	-2.3	Pass
9748.0	-53.5	-28.7	-24.8	Pass
12185.0	-64.8	-28.7	-36.1	Pass
14622.0	-69.5	-28.7	-40.8	Pass
17059.0	-71.7	-28.7	-43.0	Pass
19496.0	-73.0	-28.7	-44.3	Pass
21933.0	-75.7	-28.7	-47.0	Pass
24370.0	-76.8	-28.7	-48.1	Pass

**Table 6-4: Antenna Conducted Spurious Emissions (2475 MHz = -8.1 dBm)**

Frequency (MHz)	Level (dBm)	Limit (dBm)	Margin (dB)	Result
4950.0	-35.0	-28.1	-6.9	Pass
7425.0	-37.7	-28.1	-9.6	Pass
9900.0	-57.8	-28.1	-29.7	Pass
12375.0	-67.7	-28.1	-39.6	Pass
14850.0	-71.5	-28.1	-43.4	Pass
17325.0	-77.7	-28.1	-49.6	Pass
19800.0	-74.0	-28.1	-45.9	Pass
22275.0	-80.0	-28.1	-51.9	Pass
24750.0	-77.3	-28.1	-49.2	Pass

**Test Personnel:**

Daniel W. Baltzell  
Test Engineer

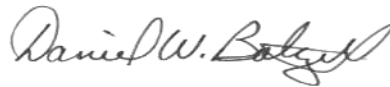

Signature

June 14, 2007  
Date Of Test



## 7 20 dB Bandwidth – FCC §15.247(a)(1); IC RSS-Gen

### 7.1 20 dB Bandwidth Test Procedure

The minimum 20 dB bandwidths per RSS-210 were measured using a 50 ohm spectrum analyzer. The modulated carrier was adjusted on the analyzer so that it was displayed entirely on the spectrum analyzer. The sweep time was auto and allowed through several sweeps with the max hold function used in peak detector mode. The resolution bandwidth was set to 100 kHz, and the video bandwidth set at 1 MHz. The minimum 20 dB bandwidths were measured using the spectrum analyzer delta marker set 20 dB down from the peak of the carrier. The table below contains the bandwidth measurement results.

**Table 7-1: 20 dB Bandwidth Test Equipment**

RTL Asset #	Manufacturer	Model	Part Type	Serial Number	Calibration Due Date
900913	Hewlett Packard	85462A	EMI Receiver RF Section (9 KHz – 6.5 GHz)	3325A00159	03/21/08

### 7.2 20 dB Modulated Bandwidth Test Data

**Table 7-2: 20 dB Modulated Bandwidth Test Data**

#### Minimum 20 dB bandwidths

Channel	20 dB Bandwidth (kHz)
1	863
37	915
75	930

### 7.3 20 dB Bandwidth Plots

Channel: 1  
Channel Frequency (MHz): 2401  
Resolution Bandwidth (kHz): 100  
Video Bandwidth (MHz): 1  
Span (MHz): 3

Plot 7-1: 20 dB Bandwidth Channel 1

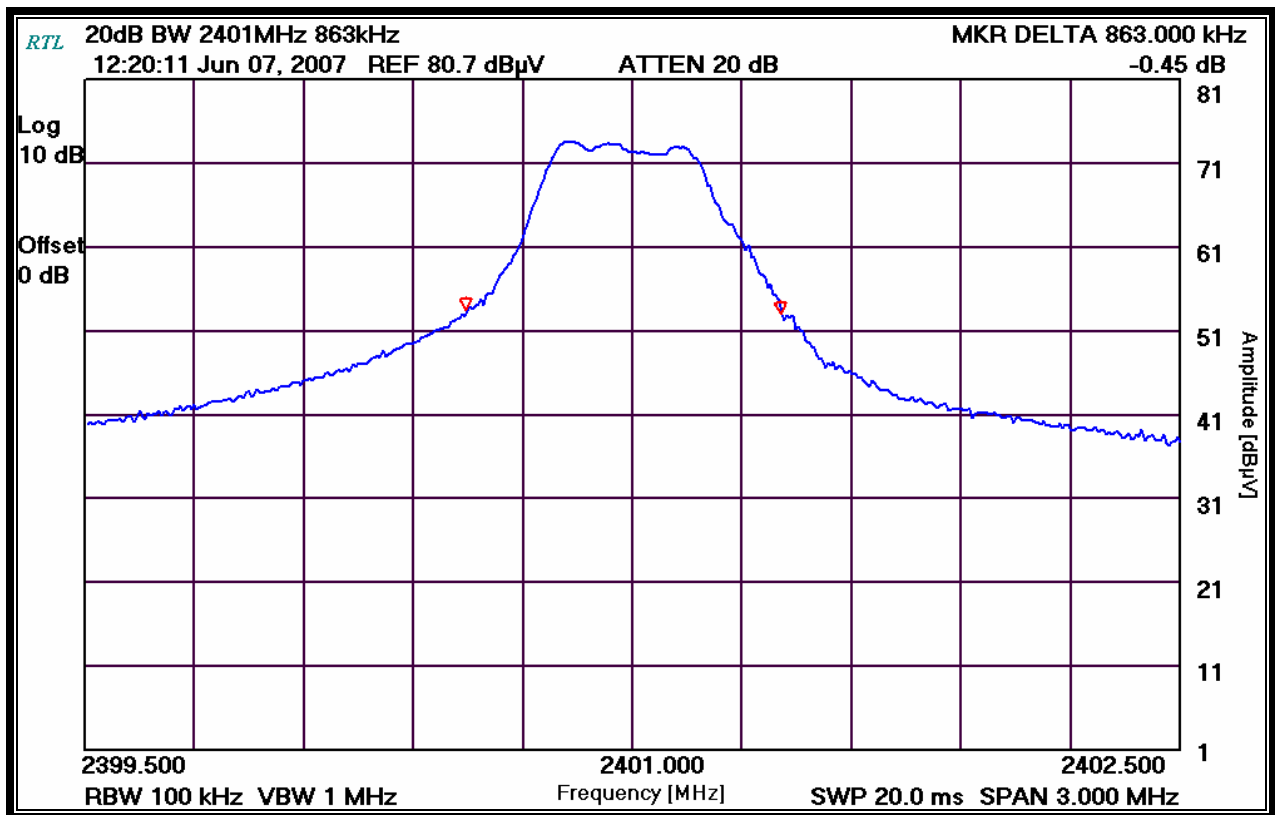

Channel: 37  
Channel Frequency (MHz): 2437  
Resolution Bandwidth (kHz): 100  
Video Bandwidth (MHz): 1  
Span (MHz): 3

Plot 7-2: 20 dB Bandwidth Channel 37

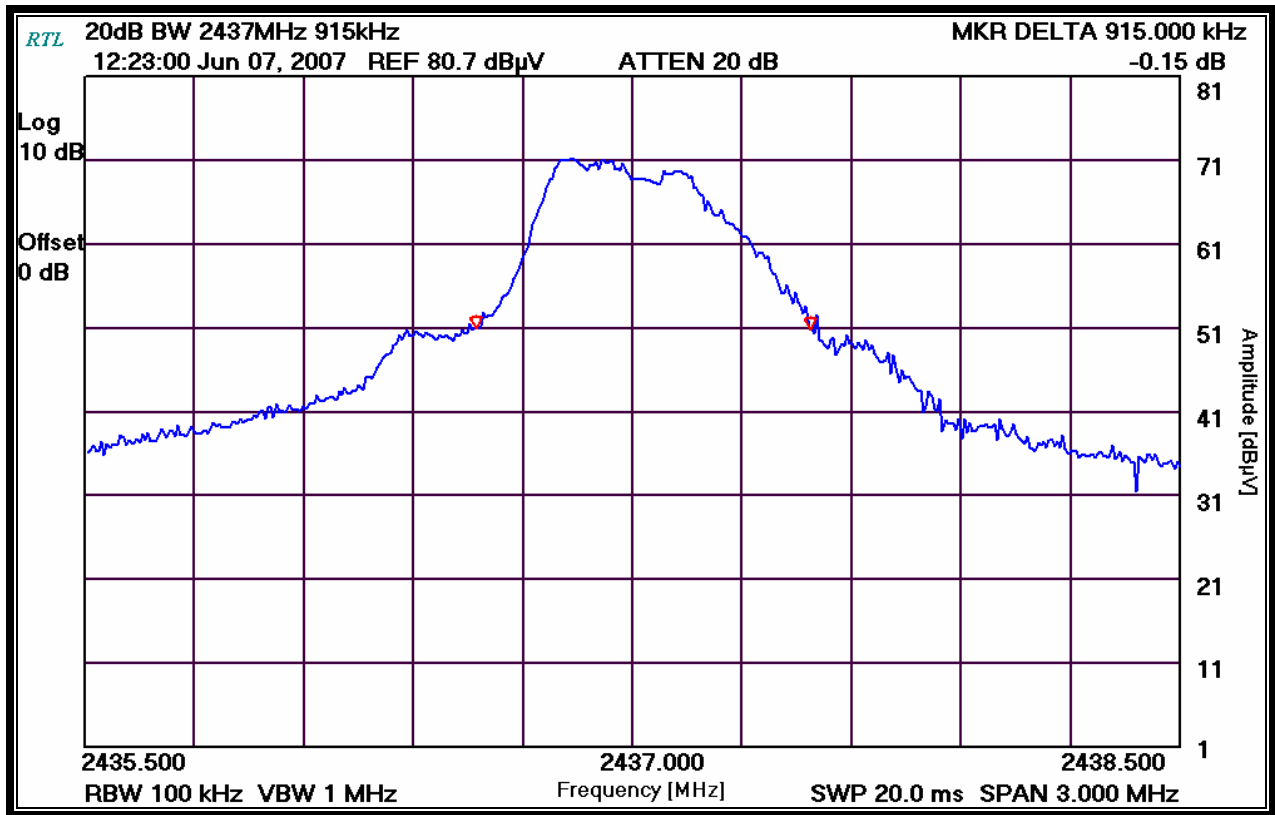

Channel: 75  
Channel Frequency (MHz): 2475  
Resolution Bandwidth (kHz): 100  
Video Bandwidth (MHz): 1  
Span (MHz): 3

Plot 7-3: 20 dB Bandwidth Channel 75

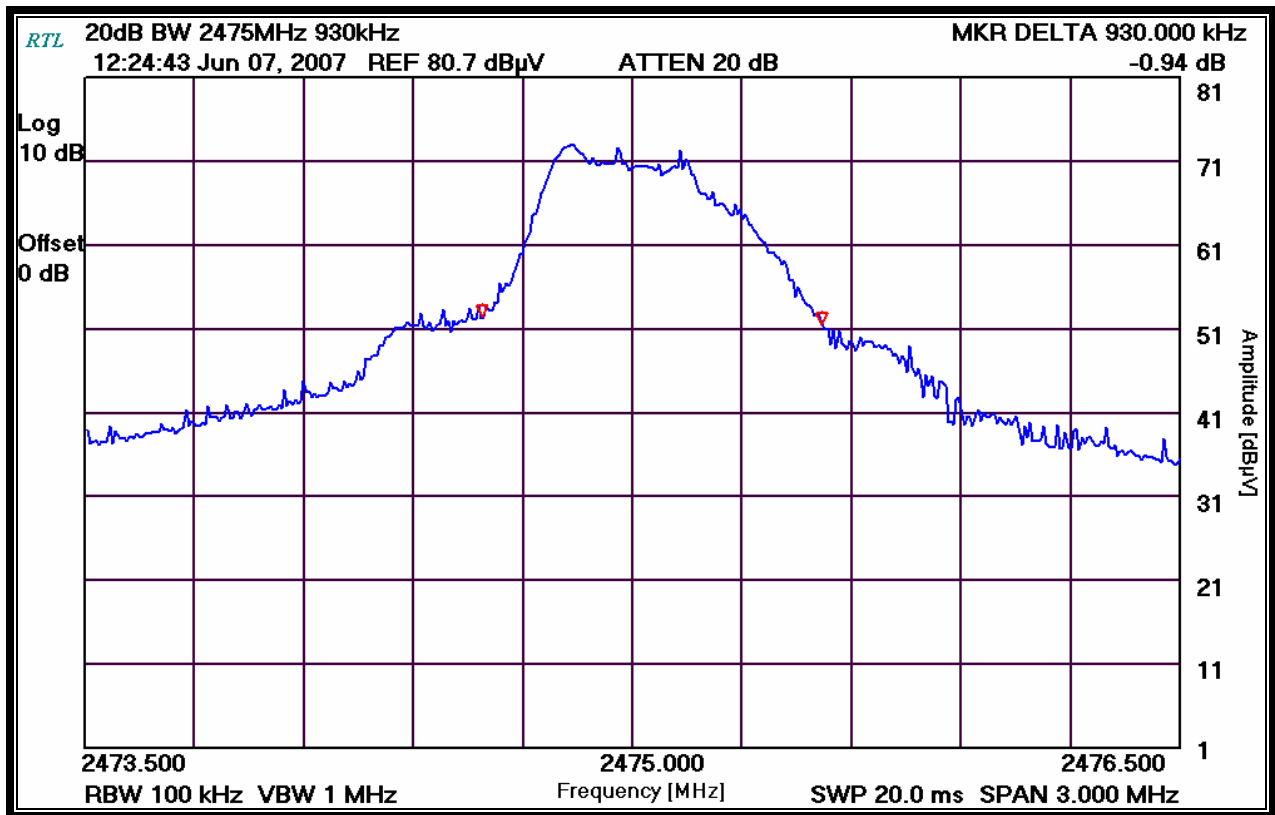

Test Personnel:

Daniel W. Baltzell  
Test Engineer

Signature

June 7, 2007  
Date Of Test

## 8 Carrier Frequency Separation - §15.247(a)(1)

### 8.1 Carrier Frequency Separation Test Procedure

Frequency Hopping systems shall have hopping channel carrier frequencies separated by a minimum of 25 kHz or the 20 dB bandwidth of the hopping channel, whichever is greater.

Measured frequency separation = 998 kHz

**Table 8-1: Carrier Frequency Separation Test Equipment**

RTL Asset #	Manufacturer	Model	Part Type	Serial Number	Calibration Due Date
900913	Hewlett Packard	85462A	EMI Receiver RF Section (9 KHz – 6.5 GHz)	3325A00159	03/21/08

### 8.2 Carrier Frequency Separation Test Data

**Plot 8-1: Carrier Frequency Separation**

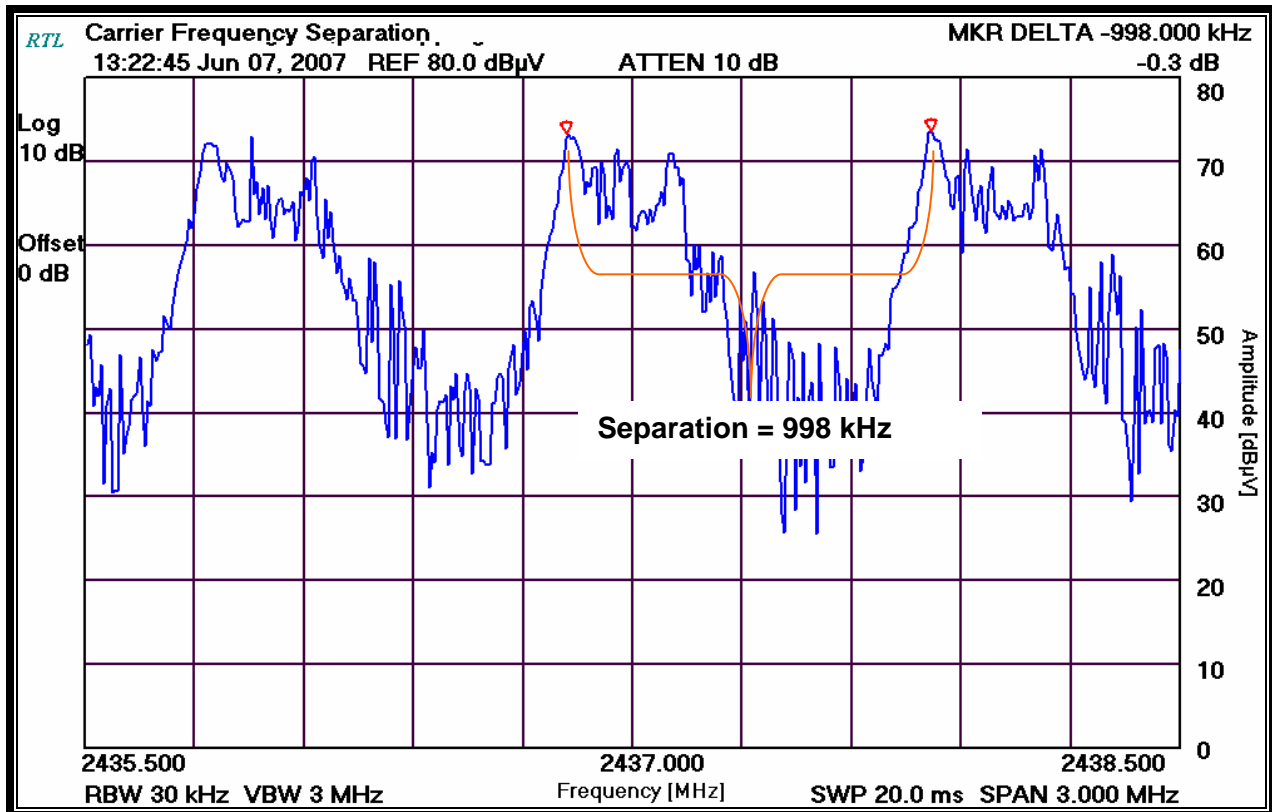

### 8.3 Hopping Characteristics Test Procedure

Frequency hopping systems in the 2400–2483.5 MHz band shall use at least 15 channels. The average time of occupancy on any channel shall not be greater than 0.4 seconds within a period of 0.4 seconds multiplied by the number of hopping channels employed. Frequency hopping systems may avoid or suppress transmissions on a particular hopping frequency provided that a minimum of 15 channels are used.

### 8.4 Number of Hopping Frequencies

Measured number of hopping frequencies = 75

Plot 8-2: Number of Hopping Frequencies

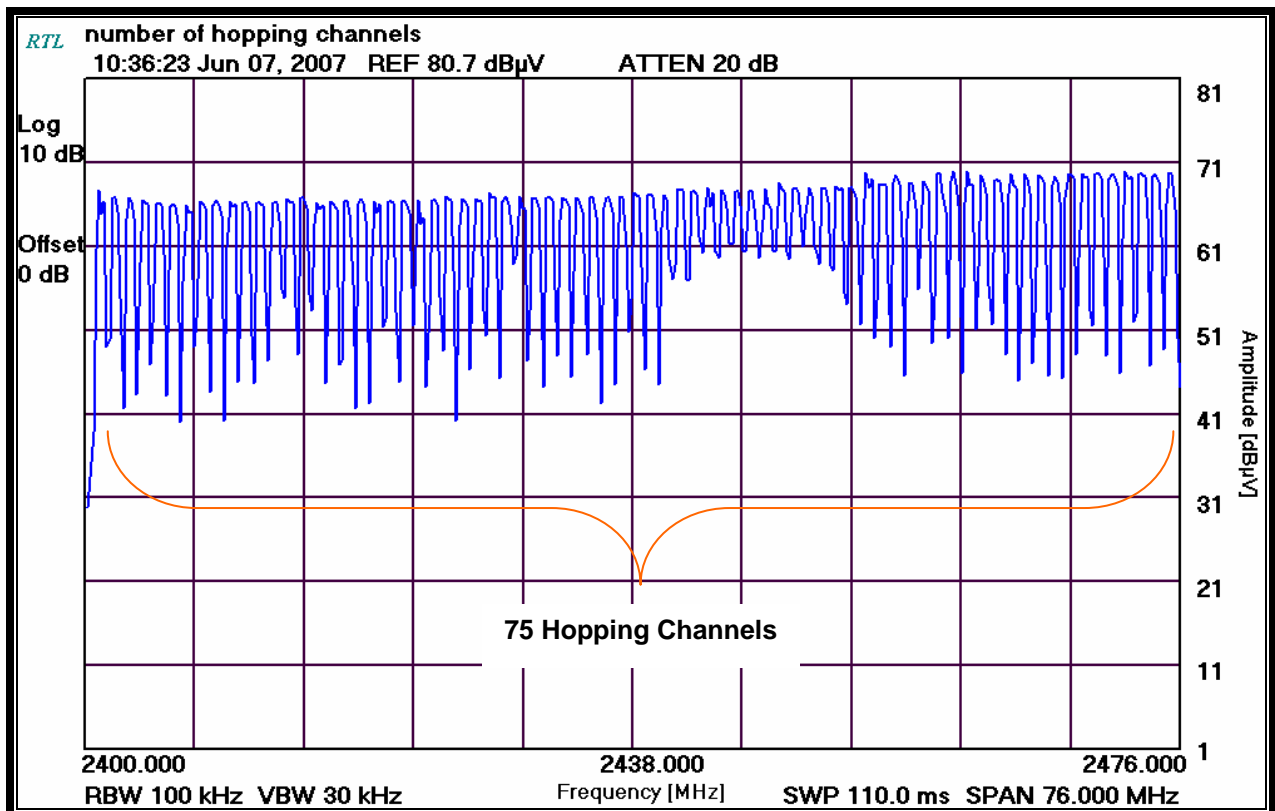

### 8.5 Average Time of Occupancy

The spectrum analyzer sweep was set to 20 ms, with a zero span and max hold until a pulse from the device under test was captured. A marker delta was used to measure the dwell time for this pulse. The sweep was then set to single sweep for 30 and the number of pulses counted.

The number of pulses in a period of 0.4 seconds X 75 hopping channels (30 s) was 101.  
 The average time of occupancy in the above period (30 s) is equal to 101 pulses X 1.05 ms = 106.1 ms, which meets the limit of 0.4 seconds as defined by 15.247(a)(1)(iii).

**Table 8-2: Time of Occupancy Test Equipment**

RTL Asset #	Manufacturer	Model	Part Type	Serial Number	Calibration Due Date
900913	Hewlett Packard	85462A	EMI Receiver RF Section (9 KHz – 6.5 GHz)	3325A00159	03/21/08

**Plot 8-3: Time of Occupancy (Dwell Time)**

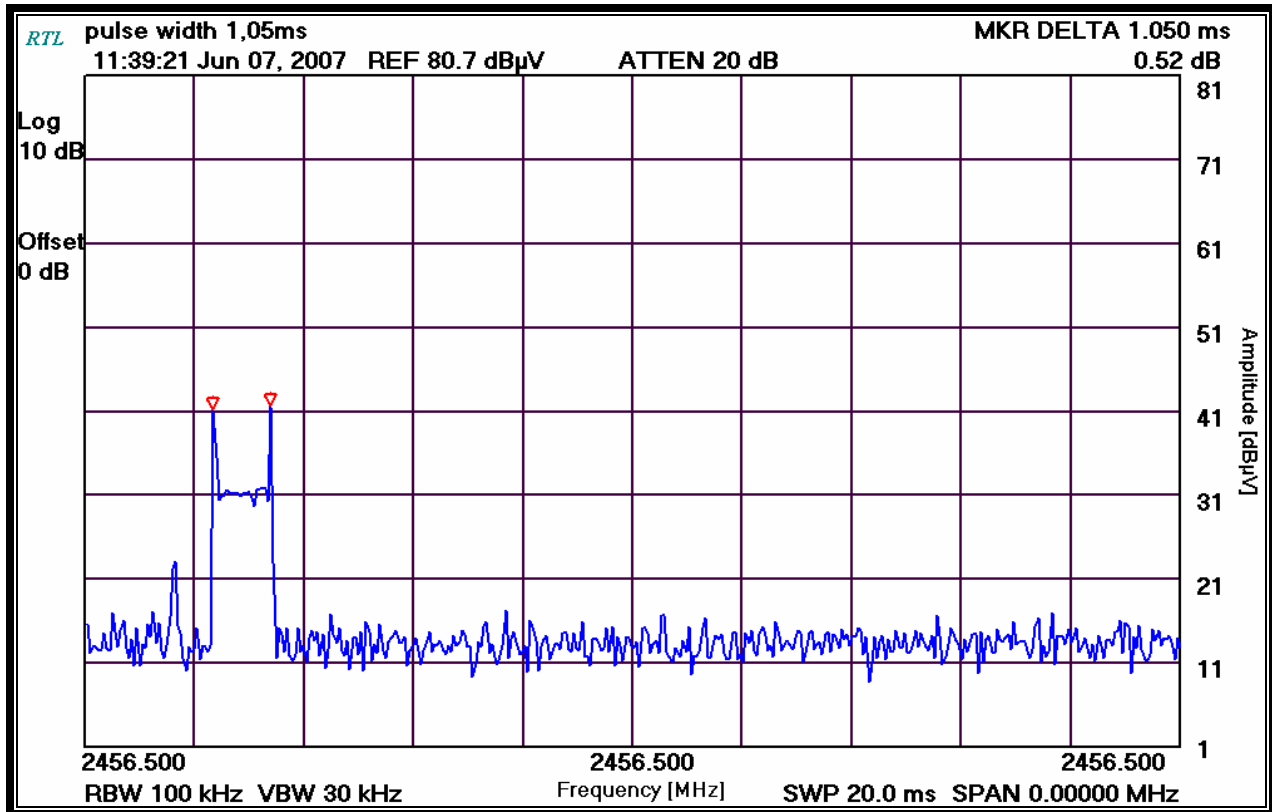

**Plot 8-4: Time of Occupancy (Dwell Time 30 Second Sweep)**

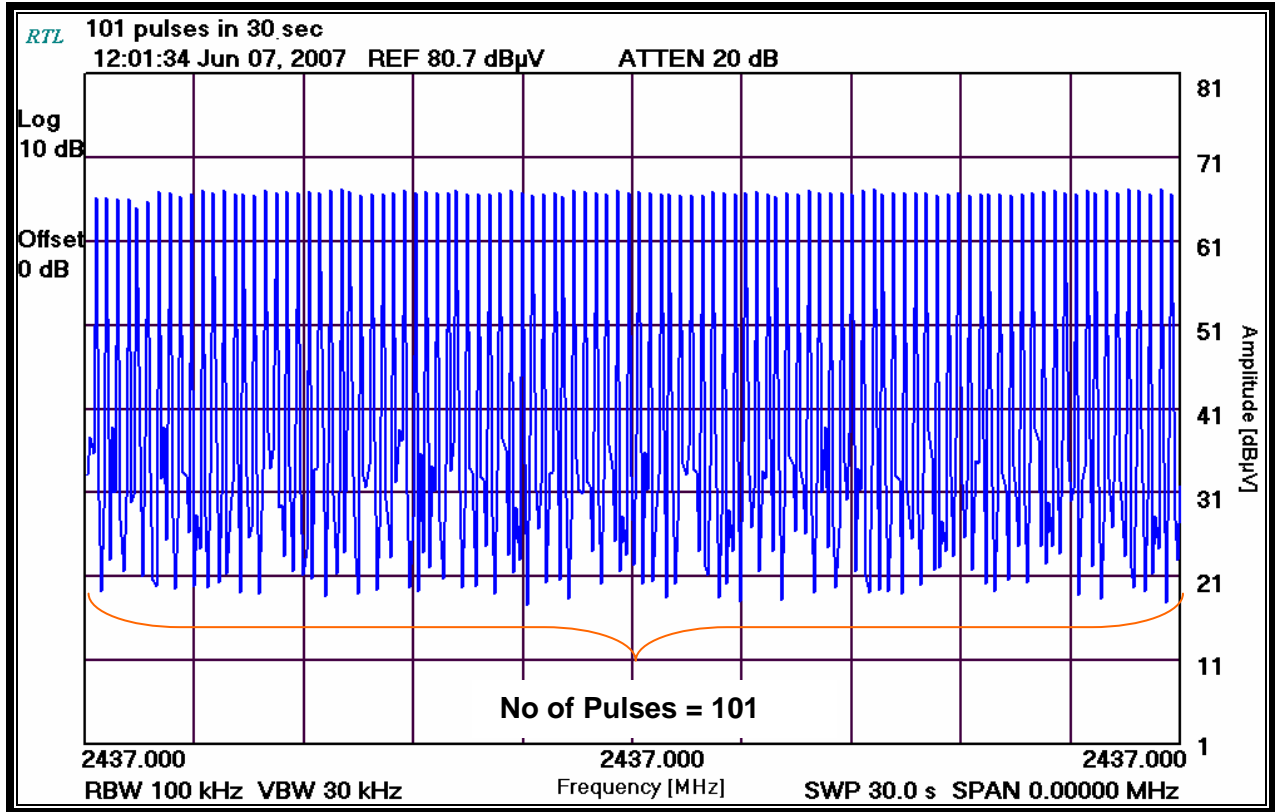

Number of pulses in 30 seconds: 101

**Test Personnel:**

Daniel W. Baltzell  
Test Engineer

Signature

June 7, 2007  
Date Of Tests



## 9 Radiated Emissions - §15.209; RSS-210 §6.2.1

### 9.1 Limits of Radiated Emissions Measurement

Frequency (MHz)	Field Strength (uV/m)	Measurement Distance (m)
0.009-0.490	2400/f (kHz)	300
0.490-1.705	2400/f (kHz)	30
1.705-30.0	30	30
30-88	100	3
88-216	150	3
216-960	200	3
Above 960	500	3

As shown in 15.35(b), for frequencies above 1000 MHz, the field strength limits are based on average detector, however, the peak field strength of any emission shall not exceed the maximum permitted average limits, specified above by more than 20 dB under any circumstances of modulation.

### 9.2 Radiated Emissions Measurement Test Procedure

Before final measurements of radiated emissions were made on the open-field three/ten meter range, the EUT was scanned indoors at one and three meter distances. This was done in order to determine its emissions spectrum signature. The physical arrangement of the test system and associated cabling was varied in order to determine the effect on the EUT's emissions in amplitude, direction and frequency. This process was repeated during final radiated emissions measurements on the open-field range, at each frequency, in order to ensure that maximum emission amplitudes were attained.

Final radiated emissions measurements were made on the three/ten-meter, open-field test site. The EUT was placed on a nonconductive turntable 0.8 meters above the ground plane. The spectrum was examined from 9 kHz to the 10<sup>th</sup> harmonic of the highest fundamental transmitter frequency (24.8 GHz).

At each frequency, the EUT was rotated 360°, and the antenna was raised and lowered from 1 to 4 meters in order to determine the emission's maximum level. Measurements were taken using both horizontal and vertical antenna polarizations. For frequencies between 30 and 1000 MHz, the spectrum analyzer's 6 dB bandwidth was set to 120 kHz, and the analyzer was operated in the CISPR quasi-peak detection mode. For emissions above 1000 MHz, emissions are measured using the average detector function with a minimum resolution bandwidth of 1 MHz. No video filter less than 10 times the resolution bandwidth was used. The highest emission amplitudes relative to the appropriate limit were measured and recorded in this report.

**Table 9-1: Radiated Emissions Test Equipment**

RTL Asset #	Manufacturer	Model	Part Type	Serial Number	Calibration Due Date
900151	Rohde and Schwarz	HFH2-Z2	Loop Antenna (9 kHz - 30 MHz)	827525/019	09/15/09
900932	Hewlett Packard	8449B OPT H02	Preamplifier (1 - 26.5 GHz)	3008A00505	09/13/07
901281	Rhein Tech Laboratories, Inc.	PR-1040	Amplifier (10 MHz - 2 GHz)	1004	01/19/08
900878	Rhein Tech Laboratories, Inc.	AM3-1197-0005	3 meter antenna mast, polarizing	Outdoor Range 1	Not Required
901425	Insulated Wire, Inc.	KPS-1503-2400-KPS	RF cable, 20'	NA	12/05/07
901424	Insulated Wire Inc.	KPS-1503-360-KPS	RF cable 36"	NA	12/05/07
901242	Rhein Tech Laboratories, Inc.	WRT-000-0003	Wood rotating table	N/A	Not Required
900913	Hewlett Packard	85462A	EMI Receiver RF Section (9 KHz – 6.5 GHz)	3325A00159	03/21/08
N/A	Hewlett Packard	8563E	Spectrum Analyzer	02816	09/06/07
900814	Electro-Metrics	EM-6961 (RGA-60)	Double Ridged Guide Antenna (1 - 18 GHz)	2310	03/30/09

### 9.3 Radiated Emissions Test Results

#### 9.3.1 Radiated Emissions Digital/Receiver Test Data

**Table 9-2: Digital/Receiver Radiated Emissions Test Data**

Temperature: 79°F Humidity: 66%										
Emission Frequency (MHz)	Test Detector	Antenna Polarity (H/V)	Turntable Azimuth (deg)	Antenna Height (m)	Analyzer Reading (dBuV)	Site Correction Factor (dB/m)	Emission Level (dBuV/m)	Limit (dBuV/m)	Margin (dB)	Pass/Fail
30.000	Qp	H	0	1.0	40.9	-11.8	29.1	40.0	-10.9	Pass
250.000	Qp	H	0	1.0	37.5	-15.1	22.4	46.0	-23.6	Pass
275.000	Qp	V	0	1.0	38.1	-14.2	23.9	46.0	-22.1	Pass
314.880	Qp	H	0	1.0	35.9	-13.0	22.9	46.0	-23.1	Pass
316.500	Qp	H	0	1.0	40.8	-12.9	27.9	46.0	-18.1	Pass
579.630	Qp	H	0	1.0	35.3	-6.4	28.9	46.0	-17.1	Pass

#### 9.3.2 Radiated Emissions Harmonics/Spurious Test Data

**Table 9-3: Radiated Emissions Harmonics/Spurious 2401 MHz**

Fundamental amplitude = 78.3 dBuV/m

Emission Frequency (MHz)	Peak Analyzer Reading (dBuV) (1 MHz RBW/VBW)	Average Analyzer Reading (dBuV) (1 MHz RBW/10 Hz VBW)	Site Correction Factor (dB/m)	Average Emission Level (dBuV/m)	Average Limit (dBuV/m)	Average Margin (dB)
4802.078	41.0	21.0	24.8	45.8	54.0	-8.2
7203.078	35.3	15.3	23.6	38.9	58.3	-19.4
9604.078	30.0	10.0	23.7	33.7	58.3	-24.6
12005.078	25.8	5.8	33.3	39.1	54.0	-14.9
14406.078	21.8	1.8	28.8	30.6	58.3	-27.7
16807.078	22.8	2.8	26.5	29.3	58.3	-29.0

**Table 9-4: Radiated Emissions Harmonics/Spurious 2437 MHz**

Fundamental amplitude = 80.5 dBuV/m

Emission Frequency (MHz)	Peak Analyzer Reading (dBuV) (1 MHz RBW/VBW)	Average Analyzer Reading (dBuV) (1 MHz RBW/10 Hz VBW)	Site Correction Factor (dB/m)	Average Emission Level (dBuV/m)	Average Limit (dBuV/m)	Average Margin (dB)
4874.084	36.2	16.2	24.9	41.1	54.0	-12.9
7311.126	31.0	11.0	24.7	35.7	54.0	-18.3
9748.168	29.2	9.2	24.8	34.0	60.5	-26.5
12185.210	26.0	6.0	29.6	35.6	54.0	-18.4
14622.252	20.3	0.3	31.3	31.6	60.5	-28.9
17059.294	24.7	4.7	29.1	33.8	60.5	-26.7

**Table 9-5: Radiated Emissions Harmonics/Spurious 2475 MHz**

Fundamental amplitude = 76.4 dBuV/m

Emission Frequency (MHz)	Peak Analyzer Reading (dBuV) (1 MHz RBW/VBW)	Average Analyzer Reading (dBuV) (1 MHz RBW/10 Hz VBW)	Site Correction Factor (dB/m)	Average Emission Level (dBuV/m)	Average Limit (dBuV/m)	Average Margin (dB)
4950.0830	38.8	18.8	25.1	43.9	54.0	-10.1
7425.1245	30.5	10.5	25.7	36.2	54.0	-17.8
9900.1660	26.2	6.2	26.2	32.4	56.4	-24.0
12375.2075	24.3	4.3	29.4	33.7	54.0	-20.3
14850.2490	21.8	1.8	30.4	32.2	56.4	-24.2
17325.2905	22.2	2.2	28.2	30.4	56.4	-26.0

**Table 9-6: Radiated Emissions Harmonics/Spurious Hopping Mode**

Fundamental amplitude = 76.4 dBuV/m

Emission Frequency (MHz)	Peak Analyzer Reading (dBuV) (1 MHz RBW/VBW)	Average Analyzer Reading (dBuV) (1 MHz RBW/10 Hz VBW)	Site Correction Factor (dB/m)	Average Emission Level (dBuV/m)	Average Limit (dBuV/m)	Average Margin (dB)
4923.4	39.2	19.2	24.8	44.0	54.0	-10.0
7345.5	30.3	10.3	24.0	34.3	54.0	-19.7
9853.1	25.2	5.2	24.8	30.0	56.4	-26.4
12319.5	25.7	5.7	29.5	35.2	54.0	-18.8
14803.4	26.2	6.2	30.8	37.0	56.4	-19.4
16826.0	25.7	5.7	28.9	34.6	56.4	-21.8

**Test Personnel:**

Daniel W. Baltzell Test Engineer	 Signature	June 13, 2007 Date Of Test
-------------------------------------	--	-------------------------------

**10 Conclusion**

The data in this measurement report shows that the EUT as tested, Fleetwood Group, Inc., Model: WRS960X, FCC ID: FBRWRS960X, IC ID: 1859A-WRS960X, complies with all the applicable requirements of Parts 2 and 15 of the FCC Rules and Regulations and IC RSS-210.