

COMMSCOPE®

FlexWave® Prism Remote Unit and RF Module

Installation Guide • FWPP-504-02 • May 2017

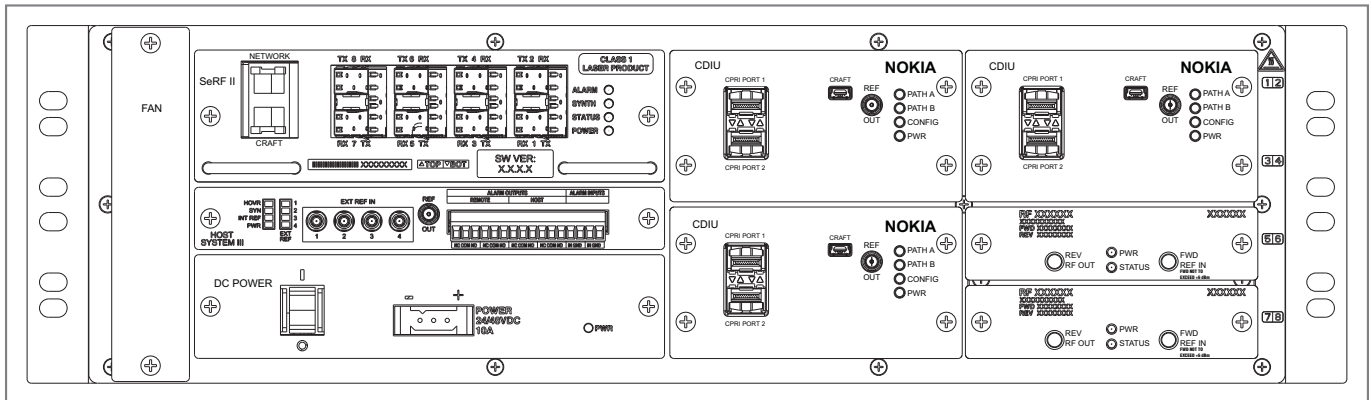

DISCLAIMER

This document has been developed by CommScope, and is intended for the use of its customers and customer support personnel. The information in this document is subject to change without notice. While every effort has been made to eliminate errors, CommScope disclaims liability for any difficulties arising from the interpretation of the information contained herein. The information contained herein does not claim to cover all details or variations in equipment, nor to provide for every possible incident to be met in connection with installation, operation, or maintenance. This document describes the performance of the product under the defined operational conditions and does not cover the performance under adverse or disturbed conditions. Should further information be desired, or should particular problems arise which are not covered sufficiently for the purchaser's purposes, contact CommScope.

CommScope reserves the right to change all hardware and software characteristics without notice.

COPYRIGHT

© 2017 CommScope, Inc. All Rights Reserved. All trademarks identified by ® or ™ are registered trademarks or trademarks, respectively, of CommScope, Inc.

This document is protected by copyright. No part of this document may be reproduced, stored in a retrieval system, or transmitted, in any form or by any means, electronic, mechanical photocopying, recording, or otherwise without the prior written permission of CommScope.

OTHER TRADEMARKS

Names of other products mentioned herein are used for identification purposes only and may be trademarks and/or registered trademarks of their respective companies.

TABLE OF CONTENTS

Document Overview	1
Document Revision History.....	3
Document Cautions and Notes.....	3
Abbreviations Used in this Guide.....	4
Overview of Prism Remote Units	5
Prism Remote Unit Components.....	6
Ports and Connectors.....	7
Bottom of an AC-Powered Quad-Bay PRU.....	8
DC-Powered Quad-Bay PRU.....	9
Remote Unit Status LED.....	10
SeRF Module LEDs.....	11
Overview of RF Modules for Prism Remote Units	12
RF Module Digital/Analog Radio Transceivers.....	12
RF Module Types.....	14
Single- and Dual-Bay RF Modules with Classic or SuperDARTs.....	15
HDM RF Modules.....	16
Legacy Dual-Bay 40W RF Modules.....	17
RF Module Components.....	18
Linear Power Amplifiers.....	19
Duplexer and Low Noise Amplifier.....	20
Digital Processing Module.....	20
Cables.....	20
LEDS on Narrowband HDM RF Modules.....	21
LEDS on Wideband and Fullband HDM RF Modules.....	22
Configuring the System with RF	23
RF Group Assignments for PRU RF Module Bays.....	23
Understanding RF Cable Rules.....	26
RF Module Cables and Supported Bay Use for Single-Card, Dual-Card, and HDM RF Modules.....	26
RF Module Cables and Supported Bay Installations for Legacy Dual-Bay 40W RF Modules.....	27
Install the Prism Remote Unit	29
Planning for a Prism Remote Unit Installation.....	29
Safety Precautions.....	29
Mounting Plans.....	30
Installation Tools and Supplies.....	36
Tools Required for All Mounting Methods.....	36
Additional Tools and Supplies Required for Steel-Pole Mounting.....	36
Additional Tools and Supplies Required for Wood-Pole Mounting.....	37
Additional Tools and Supplies Required for Flat-Surface Mounting.....	37
Tools and Supplies Required to Connect a PRU.....	38
Unpack and Inspect the Prism Remote Unit and Components.....	39
Mount the Prism Remote Unit.....	42
Mounting Cautions.....	42
Mounting Methods.....	42
Steel Pole Installation Using Steel Banding.....	43
Pole Mount Installation Using Bolts.....	46
Wood-Framed Wall Mounting Procedure.....	47
Masonry Wall Mounting.....	49
Installing a PRU on the Mounting Bracket.....	51
Ground the PRU Chassis.....	52
Connect a Network Cable to the PRU Chassis.....	54
Connect Fiber Cable to the PRU Chassis.....	56
Option A: Hardened Multi-Fiber Optic Connector.....	56
Option B: Fiber Pass-Through Connector.....	62
Option C: ProAx Connector (Legacy AC-Powered PRUs).....	67
Connect the Antenna Cable.....	71
Determine the Circuit Breaker or Fuse for the PRU.....	72
Power Consumption.....	73
Power Consumption Tables.....	74

Connect the Power Wiring	76
Option 1: Connect the AC Power Wiring	76
Option 2: Connect the DC Power Wiring	79
(Optional) Connect the Prism Remote Unit to a UPS	82
Install the RF Module(s)	84
Safety Precautions	84
Guard against Damage from Electro-Static Discharge	85
Unpack and Inspect the RF Module	85
Remove Release Liners from the RF Module	86
Check the DC Power Switch for the Module Bay	88
Dual-Bay Modules Only—Remove the Module Bay Shelf	89
Install the RF Module into the Prism Remote Chassis	90
Secure RF Module Latches	97
Connect Latches on Single-Bay and HDM RF Modules	98
Connect Latches on Dual-Bay RF Modules	99
Latches on Legacy Dual-Bay 40W RF Modules	100
Verify that the RF Module Mounting Hook is Engaged	101
Connect the RF Module Cables to the PRU Chassis	101
Connecting Cables in a Single-Bay RF Module Installation	101
Connecting Cables in a Dual-Bay RF Module Installation	106
Power on the RF Module(s) and the Prism Remote Unit	110
Close the Remote Unit Door and Solar Shield	112
Provision the Prism Remote Unit	113
FlexWave Notch Filter (FWP-SPRINTFILTER)	114
Fan Module Maintenance	118
Annual Fan Checkup	118
Potential Fan Alarms	118
Replacing the Fan Module	118
Specifications	121
Standards Certification	123
DCCS Global Technical Support	124
Telephone Helplines	124
Online Support	124
DCCS Technical Training	125
Accessing FlexWave User Documentation	126
Accessing Prism User Documentation	126
Accessing Spectrum User Documentation	126

DOCUMENT OVERVIEW

This document provides the information you need to install a CommScope FlexWave® Prism Remote Unit (PRU). Installation instructions are also provided for the following Prism Remote Unit RF Modules that reside in a PRU:

- Single-Bay RF Modules, which includes the HDM and TDD RF Modules
- Dual-Bay RF Modules, which includes the Dual-Band RF Modules and Legacy 40W RF Modules.

NOTE: RF Modules are ordered separately and must be installed in a Prism Remote Unit in the field.

Table 1 lists the Prism Remote Unit chassis and Table 2 through Table 8 on page 3 list the Prism RF Modules that this installation guide supports.

Table 1. Supported FlexWave Prism Remote Unit Chassis

Catalog Number	Description
FP1-XXXXXXXXXXRU	Single-Bay Prism Remote
FP2-XXXXXXXXXXRU	Dual-Bay Prism Remote
FP3-XXXXXXXXXXRU	Tri-Bay Prism Remote
FP4-XXXXXXXXXXRU	Quad-Bay Prism Remote

Table 2. Supported High-Density Module (HDM), Single Bay RF Modules

Catalog Number	Description
FWP-L4MT000MOD	20W Dual 700 Lower ABC, MIMO
FWP-L4MTU4MMOD	20W Dual 700 Lower ABC / 700 Upper C Non-Diversity
FWP-U4MT000MOD	20W 700 Upper C, MIMO
FWP-44MT000MOD	20W Dual 800 MIMO, with two External Filters
FWP-441T841MOD	20W Dual 800 SMR/ 1900 PCS, with 800 External Filter
FWP-C4MT000MOD	20W Dual 850 Cell/1900 PCS, Non-Diversity
FWP-B4MT000MOD	20W 850 MIMO
FWP-B410000MOD	20W 850 Wideband Cell, Non-Diversity
FWP-B810100MOD	40W 850 Wideband Cell, Non-Diversity
FWP-84MT000MOD	20W 1900 PCS MIMO, Non-Diversity
FWP-84MTA4MMOD	20W Dual 1900 PCS/2100
FWP-Z4MT000MOD	20W 2100 AWS-3 MIMO
FWP-W4MT000MOD	20W 2300 WCS, MIMO
FWP-T4MT000MOD-L	20W 2500 TDD Low, MIMO, 2496.5-2571.5 MHz
FWP-T4ST000MOD-H	20W 2500 TDD High, SISO, 2615-2690 MHz
FWP-A4MT000MOD	20W 2100 AWS MIMO, Non-Diversity
FWP-A416000MOD	20W 2100 AWS, Non-Diversity
FWP-A81T000MOD	40W 2100 AWS SISO, Non-Diversity
FWP-8416000MOD	20W 1900 PCS SISO, Non-Diversity
FWP-881T000MOD	40W 1900 PCS SISO, Non-Diversity

Table 3. *Supported Classic DART, Single Bay RF Modules*

Catalog Number	Description
FWP-I210000MOD	6.5W 800 APAC, Non-Diversity, Classic (Extended 1 MHz)
FWP-4210000MOD	6.5W 800 SMR Module, Non-Diversity
FWP-J410D00MOD	20W 850 Cell (870-890), Diversity Ready
FWP-8420000MOD	20W 1900 PCS Diversity
FWP-8410000MOD	20W 1900 PCS Non-Diversity
FWP-A420000MOD	20W 2100 AWS Diversity
FWP-A410000MOD	20W 2100 AWS Non-Diversity
FWP-B420000MOD	20W 850 Wideband Cell, Diversity

Table 4. *Supported Classic DART, Two Bay RF Modules*

Catalog Number	Description
FWP-8810000MOD	40W 1900 PCS, Non-Diversity
FWP-A810000MOD	40W 2100 AWS, Non-Diversity

Table 5. *Supported Single SuperDART, Non-Diversity, Single Bay RF Modules*

Catalog Number	Description
FWP-6216000MOD	10W 900 EGSM, Non-Diversity
FWP-K216000MOD	10W 900 P-GSM, Non-Diversity
FWP-F216000MOD	10W APAC EGSM, Non-Diversity
FWP-7416000MOD	20W 1800 GSM, Non-Diversity
FWP-9416D00MOD	20W 2100 UMTS Module, Diversity Ready
FWP-9416000MOD	20W 2100 UMTS, Non-Diversity
FWP-L416000MOD	20W 700 Lower ABC Module, Non-Diversity
FWP-U416000MOD	20W 700 LTE, UPPER C, SISO, Non-Diversity
FWP-U816100MOD	40W 700 Upper C, Non-Diversity

Table 6. *Supported Dual SuperDART, Single Bay, Non-Diversity RF Modules*

Catalog Number	Description
FWP-741S000MOD	20W 1800 GSM
FWP-841S000MOD	20W 1900 PCS
FWP-A41S000MOD	20W 2100 AWS
FWP-941S000MOD	20W 2100 UMTS

Table 7. Supported Single SuperDARTs, Diversity, Single Bay RF Modules

Catalog Number	Description
FWP-6226000MOD	10W 900 EGSM
FWP-K226000MOD	10W 900 P-GSM
FWP-7426000MOD	20W 1800 GSM
FWP-9426000MOD	20W 2100 UMTS
FWP-A426000MOD	20W 2100 AWS
FWP-8426000MOD	20W 1900 PCS

Table 8. Supported Dual Classic DART, Two Bay RF Modules

Catalog Number	Description
FWP-D210000MOD	6.5W 800/900 ESMR, Non-Diversity

Document Revision History

Issue	Document Date	Technical Updates
FWPP-504-02	May 2017	Adds support for RF Module FWP-Z4MT000MOD (20W 2100 AWS-3 MIMO); see Table 2 on page 1 .
FWPP-504-01	July 2016	The initial release of this installation guide (FWPP-504-01) was released when CommScope acquired TE Connectivity's telecom, enterprise and wireless business, which included the FlexWave Prism product line. CommScope document FWPP-504-01 replaced TE document TECP-77-275. FWPP-504-01 also added support for the HDM TDD RF Modules FWP-T4MT000MOD-L (20W 2500 TDD Low, MIMO, 2496.5-2571.5 MHz) and FWP-T4ST000MOD-H (20W 2500 TDD High, SISO, 2615-2690 MHz), changed RF Module installation instructions as PRUs no longer ship with any RF Modules factory installed, and added cautions to ensure that the AC/DC Power switch to the Remote Unit chassis and the DC power switch to all RF Module bays are in their OFF position before connecting or disconnecting coaxial cables.

DOCUMENT CAUTIONS AND NOTES

Two types of messages, identified below, appear in the text:

CAUTION! Cautions indicate operations or steps that could cause personal injury, induce a safety problem in a managed device, destroy or corrupt information, or interrupt or stop services.

NOTE: Notes contain information about special circumstances.

ABBREVIATIONS USED IN THIS GUIDE

AC	Alternating Current	M	Meter
AMP	Amperes	Mbps	Megabits Per Second
AUX	Auxiliary	MDI	Medium Dependent Interface
AWG	American Wire Gauge	MHz	Megahertz
C	Centigrade	MIMO	Multiple-Input Multiple-Output
CAT	Category	MM	Millimeter
CDRH	Center for Diseases and Radiological Health	MOD	Module
cm	Centimeter	MPE	Maximum Permissible Exposure
DART	Digital/Analog Radio Transceiver	NC	Normally Closed
dB	Decibel	NO	Normally Open
dBm	Decibel-milliwatts	NOC	Network Operations Center
DC	Direct Current	OSP	Outside Plant
DCS	Distributed Call Signaling	PA	Power Amplifier
DD	Digital Dividend	PA	Power Amplifier
DIV	Diversity	PRIM	Primary
DPA	Dynamic Phase Alignment	PRU	Prism Remote Unit
DPM	Digital Processing Module	PWR	Power
EMEA	Europe, Middle east, Africa	REV	Reverse
EMC	Electromagnetic Compatibility	RF	Radio Frequency
ESD	Electro-Static Discharge	Rx	Receive
EU	European Union	SDART	Super Digital/Analog Radio Transceiver
F	Fahrenheit	SeRF	Serialized RF
FCC	Federal Communications Commission	SFP	Small Form-Factor Pluggable
FDA	Food and Drug Administration	SYNTH	Synthesizer
FRU	Fullband Remote Unit	TDD	Time-Division Duplex
FWD	Forward	TIM	Thermal-Interface Material
HDM	High Density Module	Tx	Transmit
HMFOC	Hardened Multi-Fiber Optic Connector	UL	Underwriters' Laboratories, Inc.
Hz	Hertz	UMTS	Universal Mobile Telecommunications System
IC	Industry Canada	UPS	Uninterrupted Power Supply
IP	Internet Protocol	VAC	Volts, Alternating Current
LAN	Local Area Network	W	Watt
LC	Lead Covered	WCS	Wireless Communications Services
LED	Light-Emitting Diode	WDM	Wavelength Division Multiplexer
LVDS	Low-Voltage Differential Signaling		

OVERVIEW OF PRISM REMOTE UNITS

FlexWave PRUs control RF emissions, interface with the FlexWave Prism Host Unit II and perform the optical to electrical conversion for transport to the antennas. The PRU is an environmentally-sealed unit designed for outdoor use that houses the electronic assemblies such as the Digital/Analog Radio Transceiver (DART) board and the Power Amplifier, and seals out dirt and moisture. The PRU uses fans located on the top of each unit to cool its chassis. The antenna cable connectors, fiber connectors, AC or DC power connector, and the unit status indicator are located on the bottom of the unit.

A PRU supports or provides the following basic functions:

- Receives on the forward path the digitized spectrum from the Host and converts the spectrum back into an RF signal to be distributed via an externally mounted antenna system. On the reverse path, the PRU digitizes the designated RF spectrum and digitally transports it over single mode fiber or Millimeter Wave (MMW) to the Host.
- Provides RF interface (antenna port) for the antennas.
- Accepts either AC or DC power input.

PRISM REMOTE UNIT COMPONENTS

Figure 1 shows the main components of the PRU and its corresponding RF Modules.

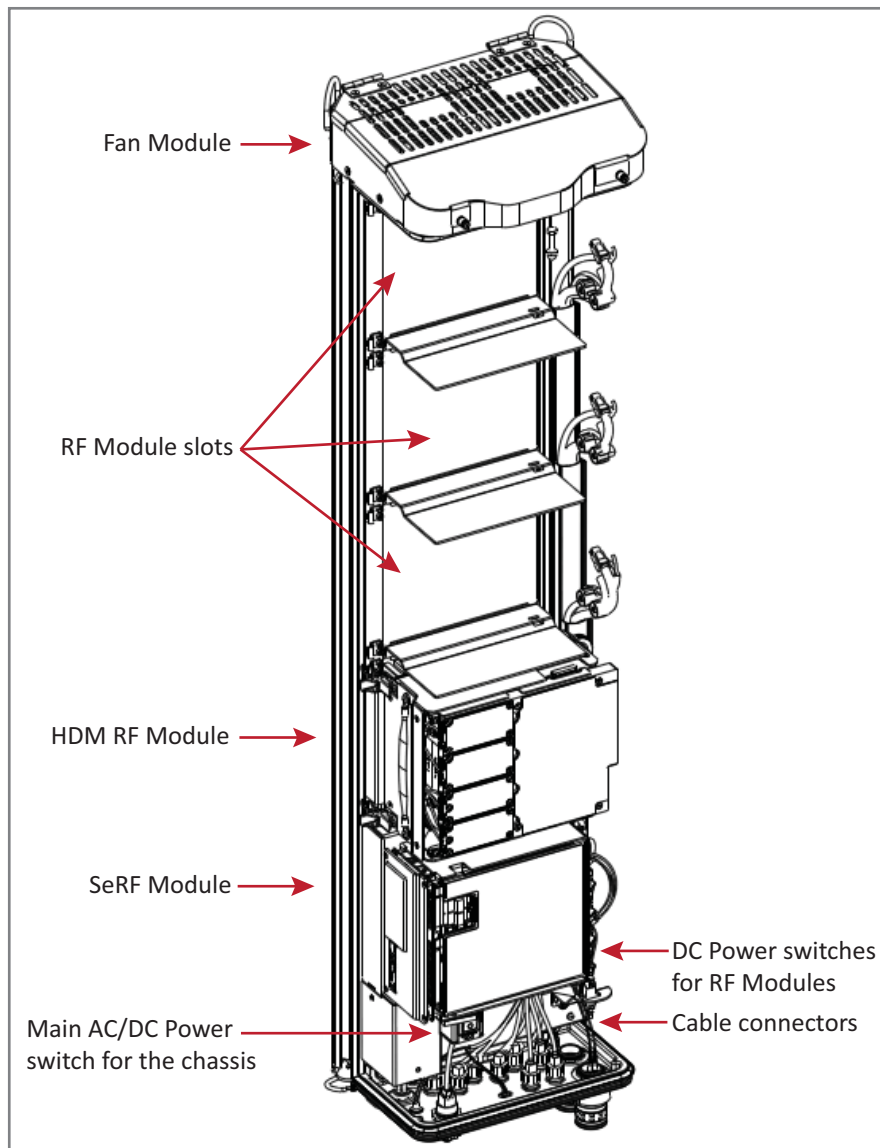

Figure 1. Prism Remote Unit Components

PORTS AND CONNECTORS

Make sure you refer to the section that describes the PRU deployed in your installation. "[Bottom of an AC-Powered Quad-Bay PRU](#)" on page 8 and "[DC-Powered Quad-Bay PRU](#)" on page 9 shows the differences between an AC-powered and a DC-powered PRU. The differences will be the same for Single-Bay, Dual-Bay, and Tri-Bay chassis. Additionally, for both the AC-Powered and DC-Powered PRUs:

- The number of Antenna connectors on the bottom of a PRU corresponds to the number of RF Module bays in that PRU model, where there are two Antenna connectors per bay. For example:
 - There are four RF Module bays in a Quad-Bay PRU, so there are eight Antenna connectors.
 - There is one RF Module bay in the Single-Bay PRU, so there are two Antenna connectors.
- The Single-Bay PRU only has one Fiber connector whereas the other three PRU models have two.

Bottom of an AC-Powered Quad-Bay PRU

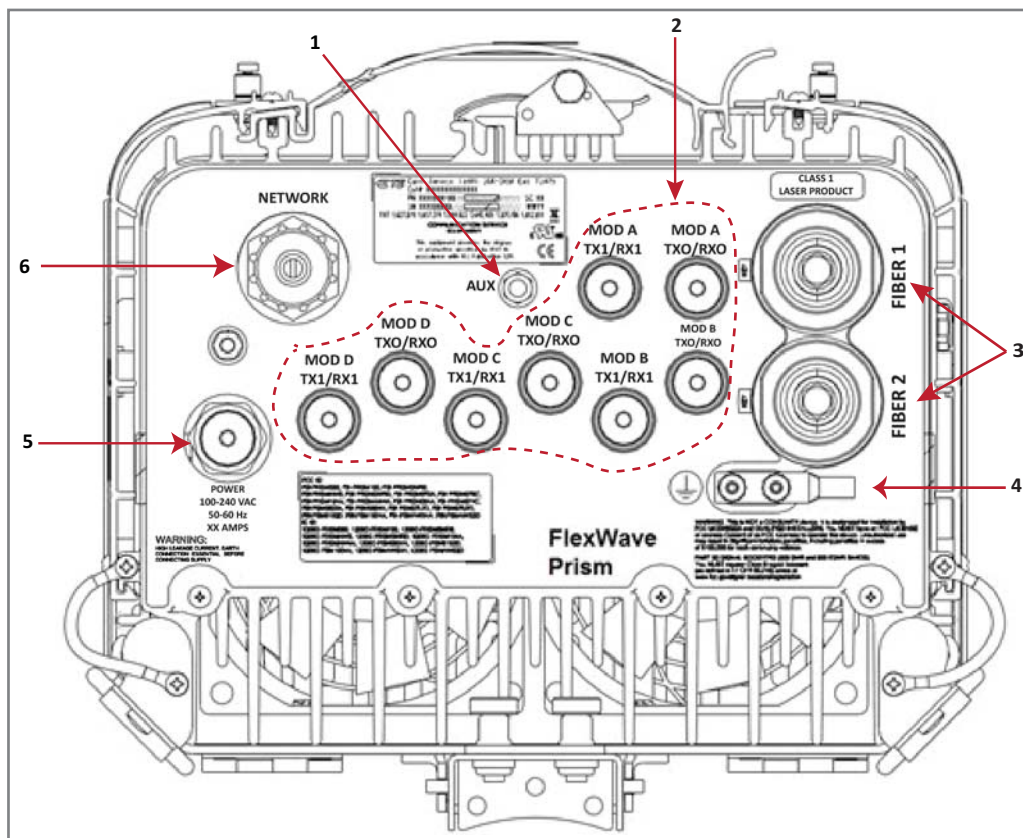

Ref #	Component	Device	Function
1	AUX connector	Four contact closure inputs	Connection points for two external alarm inputs.
2	Antenna connectors	Eight Input/Output Impedance 50Ω N-Type connectors (female)	Connection points between the PRU and antennas that are labeled Mod X TXO/RXO or Mod X TX1/RX1 (where the first X can be A, B, C, or D). For further information, see "Understanding RF Cable Rules" on page 26.
3	Fiber connectors	One of the following: <ul style="list-style-type: none"> • Hardened Multi-Fiber Optic Connector (shown) • Fiber Pass-Through • ProAx connectors that provide four BX5 connectors (Legacy PRUs) 	Connection points between the PRU and the Outside Plant (OSP) box. The Single-BAY PRU only has the Fiber 1 connector. For further information on the three Fiber connector types, see "Connect Fiber Cable to the PRU Chassis" on page 56.
4	Dual-Ground connector	Ground connector	Grounds the PRU.
5	AC Power port	Sealed 3-pin port	Connection point between the PRU and an AC power junction box.
6	Network Connector port	RJ-45 female connector	LAN Extension of the Host Unit Network that provides access to the Prism Network for access and monitoring via an up to a 100 Mbps IP back-haul connection to remote devices.

DC-Powered Quad-Bay PRU

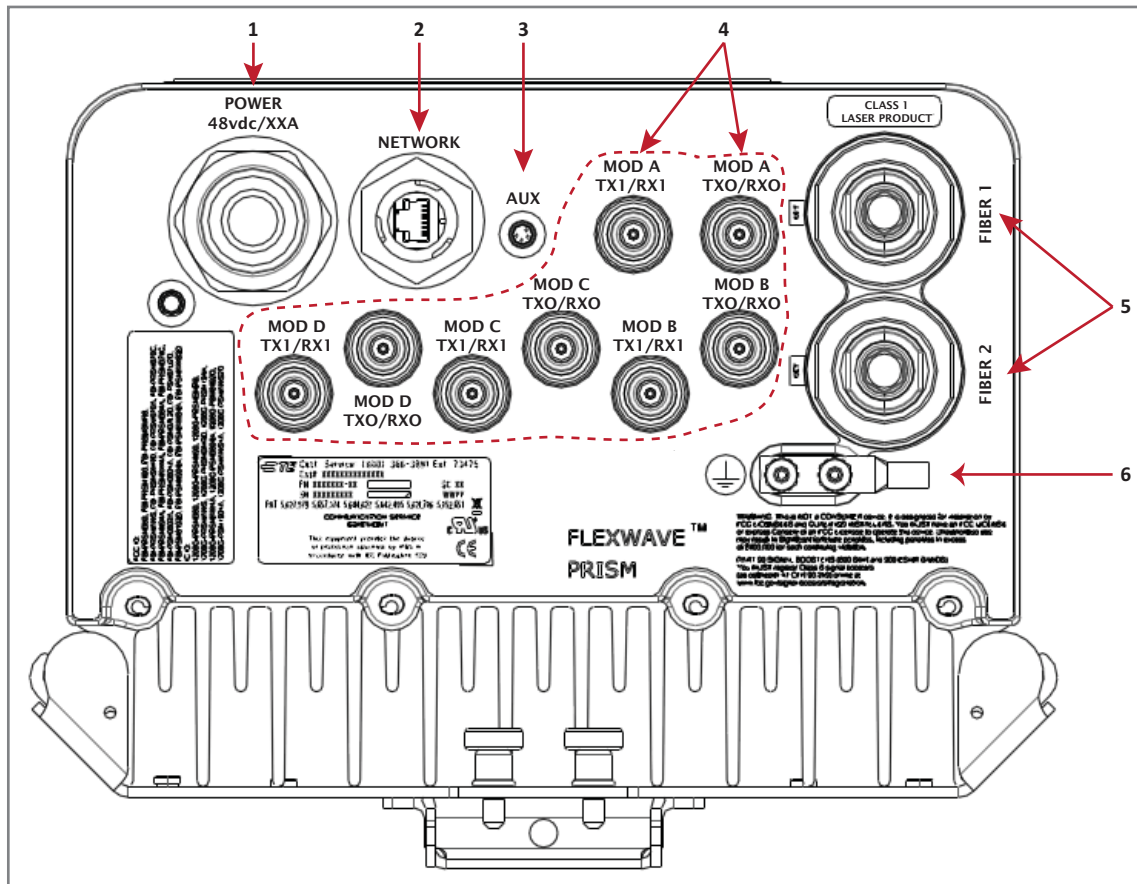

Ref #	Component	Device	Function
1	DC Power port	Pass-through gland	Connection point between the PRU and a -40 to -60 Vdc power source.
2	Network Connector port	RJ-45 female connector	LAN Extension of the Host Unit Network that provides access to the Prism Network for access and monitoring via an up to a 100 Mbps IP back-haul connection to remote devices.
3	AUX connector	Four contact closure inputs	Connection points for two external alarm inputs.
4	Antenna connectors	Eight Input/Output Impedance 50Ω N-Type connectors (female)	Connection points between the PRU and up to eight antennas that are labeled Mod X TXO/RXO or Mod X TX1/RX1 (where the first X can be A, B, C, or D). For further information, see " Understanding RF Cable Rules " on page 26.
5	Fiber connectors	One of the following: <ul style="list-style-type: none"> Hardened Multi-Fiber Optic Connector (shown) Fiber Pass-Through ProAx connectors that provide four BX5 connectors (Legacy PRUs) 	Connection points between the PRU and the Outside Plant (OSP) box. For further information on the three Fiber connector types, see " Connect Fiber Cable to the PRU Chassis " on page 56.
6	Dual-Ground connector	Ground connector	Grounds the PRU.

Remote Unit Status LED

This section illustrates the Status LED on a Quad-Bay PRU. The Status LED for the Single-Bay, Dual-Bay, and Tri-Bay PRUs is in the same location and functions the same as the Status LED for the Quad-Bay PRU.

The Remote Unit has a single red Status LED that is located on the bottom of the chassis. At system startup, the Status LED is red to indicate that the Remote Unit is powering up and that the SeRF processor does not yet control the Remote Unit; the Status LED will remain red for approximately one minute. If after three minutes the Status LED is still red, it indicates the Remote Unit is unable to boot up. (Some common failures that can prevent the PRU from booting up include a faulty Power Supply, SeRF, or Compact Flash Card.)

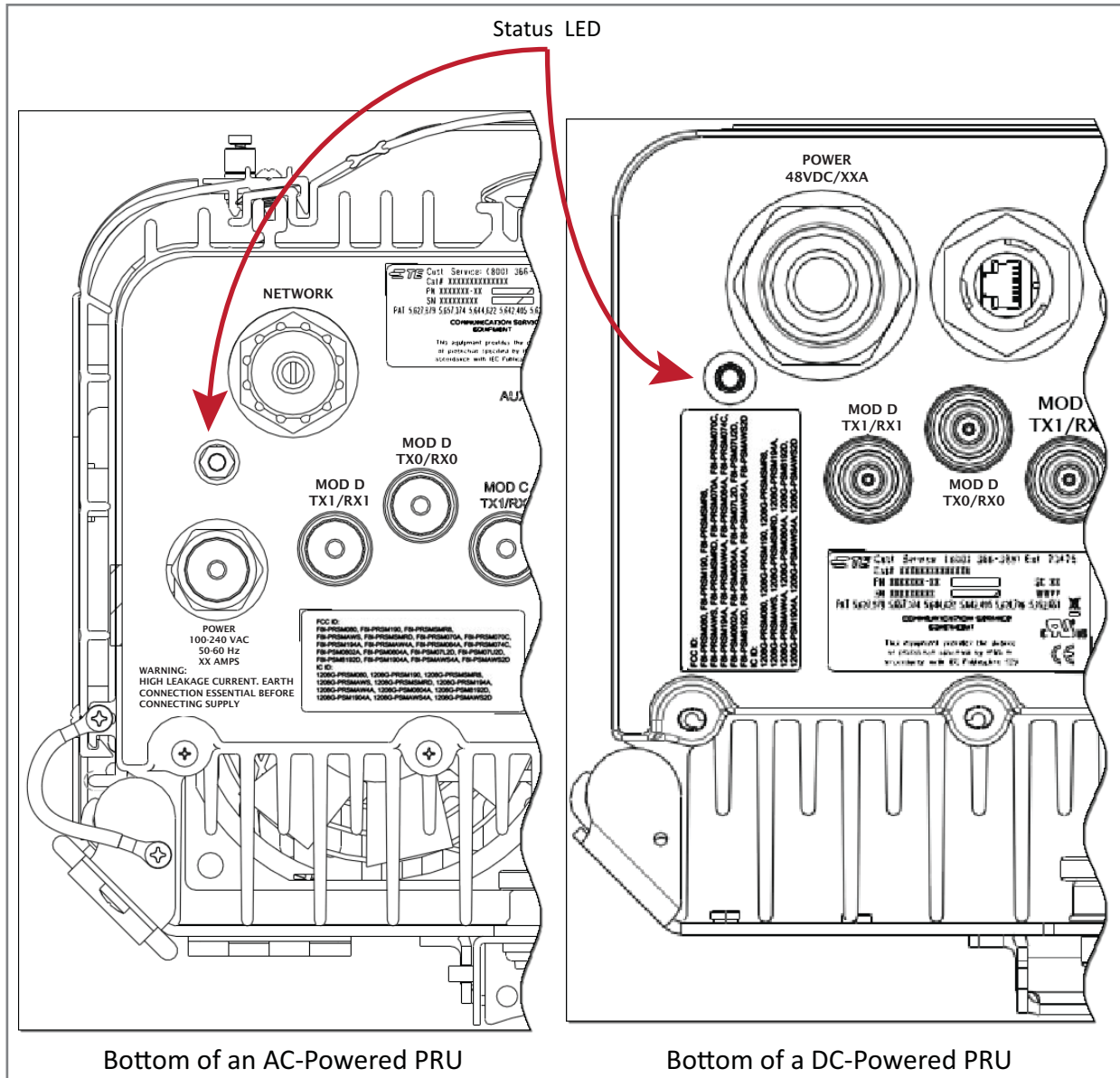

SeRF Module LEDs

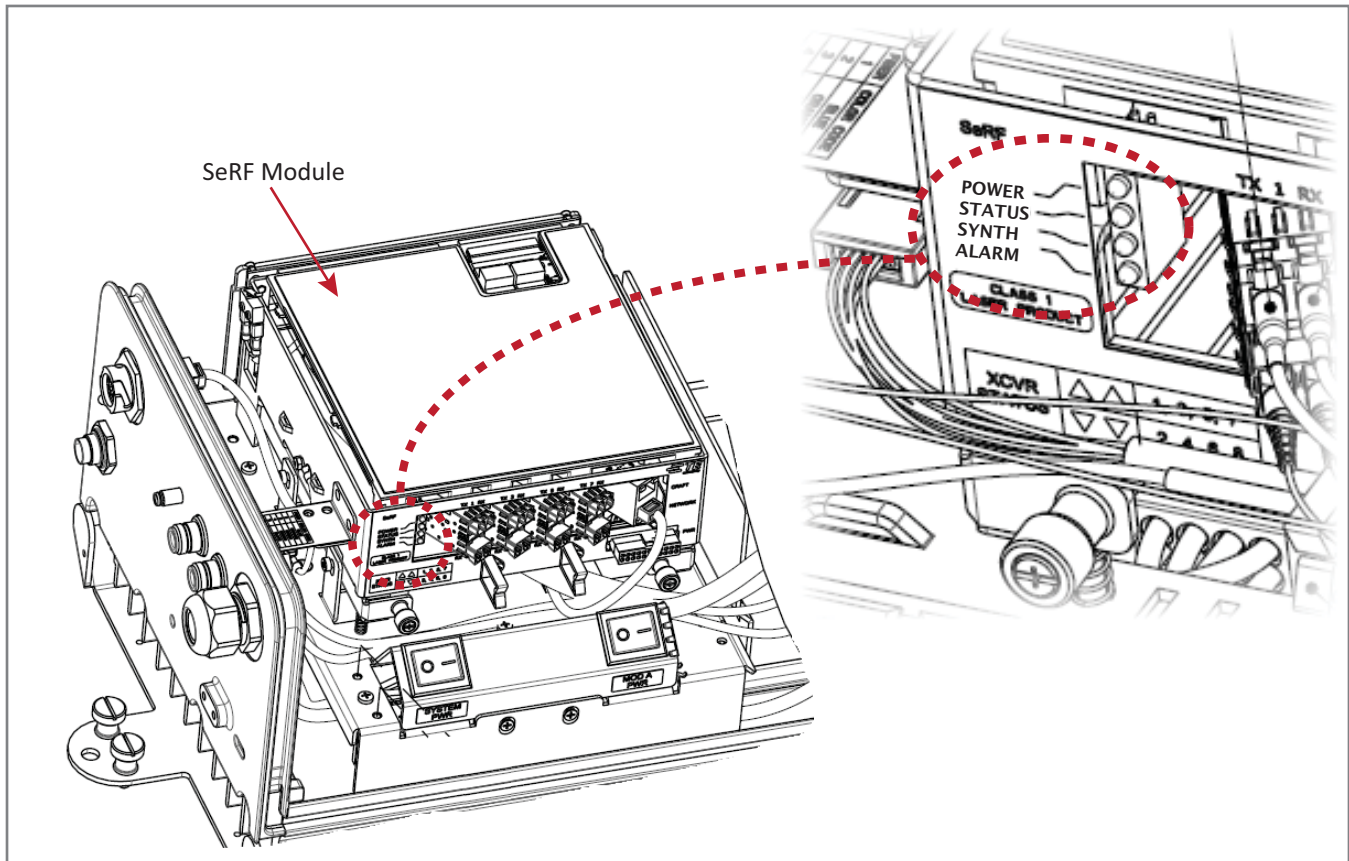

LED	LED Color	Description
POWER	• GREEN	• Power OK and operating properly
	• RED	• Power supply out of tolerance
	• OFF	• No power present
STATUS	• GREEN	• No alarm for the SeRF II Module
	• RED	• Initial bootup sequence and should become GREEN within 1 minute; if RED after bootup, a Major alarm exists for the SeRF Module
SYNTH	• GREEN	• Locked
	• RED	• Unlocked or is in initial bootup sequence
ALARM	• GREEN	• No major alarm is present in the PRU or in any downstream unit
	• RED	• Initial bootup sequence, or a major alarm is present in the PRU or in any downstream unit

NOTE: The SeRF Module LEDs automatically enter a LED Roll Test sequence (cycle through its colors) when the SeRF FPGA is loaded (approximately 4 minutes after initial power up) or when a SeRF synthesizer failure occurs. The LED Roll Test sequence takes approximately two seconds to complete, and cycles the ALARM, SYNTH, and STATUS LEDs, after which the LEDs begin normal operation. Additionally, an active SeRF Synthesizer failure causes the same LED sequencing approximately every minute until the SeRF failure clears.

OVERVIEW OF RF MODULES FOR PRISM REMOTE UNITS

Dependent on the Prism Remote Unit model, a PRU enclosure can have from one to four RF Module bays and can support up to four RF Modules, as indicated by the model name. That is, the Single-Bay PRU has one RF Module bay and can only support one RF Module, and the Quad-Bay PRU has four RF Module bays and can support up to four RF Modules.

The function of the Remote Unit RF Modules on the Forward Path is to:

- convert the digitized RF transported from the Host to Analog RF
- amplify the Analog RF signal
- provide signal filtering.

The function of the Remote Unit RF Modules on the Reverse Path is to:

- convert the Analog RF from the handset to Digital RF for transport to the Host
- amplify the Digital RF signal
- provide signal filtering.

NOTE: The RF Modules are field replaceable, but cannot be serviced in the field.

RF MODULE DIGITAL/ANALOG RADIO TRANSCEIVERS

Each RF Module can support any of the following Digital/Analog Radio Transceiver (DART) combinations:

- one Classic DART or one Single SuperDART
- two Classic DARTs (i.e., the 6.5W 800/900 ESMR Module, Non-Diversity, Classic)
- two Classic DARTs—Diversity
- two Single SuperDARTs—Diversity
- one Dual SuperDART
- one or two sets of Tx and Rx Boards (HDM).

Each RF Module will have up to two 6-timeslot DARTs or one 12-timeslot DART per RF Module.

The DART type determines the maximum number of links, where there can be up to eight Classic DARTs or Single SuperDARTs that support 35 MHz each, or up to 4 Dual SuperDARTs that support up to 75MHz each.

Prism supports the DART Module types listed below.

- Classic DARTs are 6-timeslot DARTs that support up to 35 MHz contiguous bandwidth (see [Table 9](#)).
- Single SuperDARTs are 6-timeslot DARTs that support two non-contiguous bands in the entire frequency range of the DART, but cannot exceed 35 MHz total RF bandwidth (see [Table 10](#)).
- Dual SuperDARTs are 12-timeslot DARTs that support up to 60-75 MHz (see [Table 11 on page 14](#))

NOTE: Industry Canada PCS 20 dB nominal bandwidth is less than 61.5 MHz.

NOTE: Industry Canada AWS 20 dB nominal bandwidth is less than 47.2 MHz

Table 9. Single-Position Classic DARTs

DART Module Type	Maximum Bandwidth (MHz)	Maximum Fiber Slots
800 APAC iDEN Classic	19	3
800 SMR Classic	7*	3
850 Cell Classic	25	4
900 SMR Classic	5	1
* Classic Prism RF Modules and Spectrum RAU support 18 MHz; Prism HDM 800 only supports 7 MHz, per Sprint direction.		

Table 10. Single-Position SuperDARTs*

DART Name	Used in...		Maximum Frequency Span (MHz)	Maximum Bandwidth (MHz)	Maximum Fiber Slots
	Host Units	HEUs			
700 IABC SGL SuperDART	Yes	Yes	18	18	3
700 uC SGL SuperDART	Yes	Yes	10	10	2
900 EGSM SGL SuperDART	Yes	No	35	35	6
1800 GSM SGL SuperDART	Yes	No	75	35	6
1900 PCS SGL SuperDART	Yes	Yes	70	35	6
2100 AWS SGL SuperDART	Yes	Yes	45	35	6
20W 2100 AWS-3 MIMO	Yes	Yes	70	35	12
2100 UMTS SGL SuperDART	Yes	No	60	35	6
2300 WCS, MIMO	Yes	No	10	10	2
2500 TDD Low, MIMO	Yes	No	75	35	6
2500 TDD High, SISO	Yes	No	75	75	12
* When using a Host Unit with both a SeRF II and System Board II or III, the bandwidths and fiber for the following Single SuperDARTs can be greater than 6 fiber slots, for full-band capability, when used in Host Unit Slots 1 and 3: 1800 GSM SGL SuperDART; 1900 PCS SGL SuperDART; 2100 AWS SGL SuperDART; 2100 UMTS SGL SuperDART. This requires 12 fiber slots when full-band passband is selected for these Single SuperDARTs in Host Unit DART positions 1 and 3.					

Table 11. *Dual-Position SuperDARTs*

DART Module Type	Maximum Bandwidth (MHz)	Maximum Fiber Slots
1800 GSM DL SuperDART	75	12
1900 PCS DL SuperDART	70	12
2100 AWS DL SuperDART	45	8
2100 UMTS DL SuperDART	60	12

RF MODULE TYPES

The Remote Unit RF Modules are available in the following formats, and as described in the following sections:

- ["Single- and Dual-Bay RF Modules with Classic or SuperDARTs"](#) on page 15
- ["HDM RF Modules"](#) on page 16
- ["Legacy Dual-Bay 40W RF Modules"](#) on page 17.

Single- and Dual-Bay RF Modules with Classic or SuperDARTs

Figure 2 shows examples of Single- and Dual-Bay RF Modules, both of which have two DARTs.

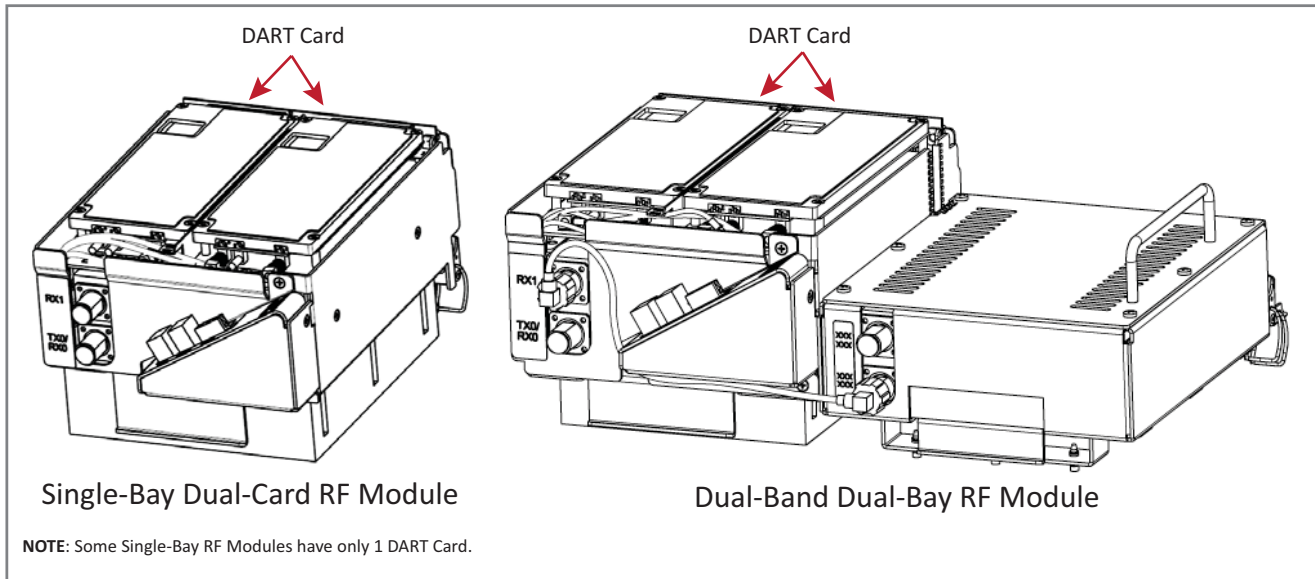

Figure 2. Single- and Dual-Bay RF Modules

Single-Bay RF Modules have the following elements:

- one or two DARTs
- one Duplexer that comprises
 - one Low Noise Amplifier (LNA)
 - one Power Detector (PD)
- one Linear Power Amplifier (LPA)
- one Remote DART Interface (RDI) board.

Dual-Band Dual-Bay RF Modules have the following elements:

- two DARTs
- two Duplexers, each of which comprises
 - one Low Noise Amplifier (LNA)
 - one Power Detector (PD)
- one Linear Power Amplifier (LPA)
- one Remote DART Interface (RDI) board.

HDM RF Modules

High-Density Module (HDM) RF Modules ([Figure 3](#)) are designed to provide the ability to deploy either a two 20W Multiple Input Multiple Output (MIMO) paths of the same band, known as a MIMO RF Module; two 20W Single Input Single Output (SISO) with two different bands, known as dual RF Module; or a single 40W Single Input Single Output (SISO) RF Module within a single-bay of a PRU.

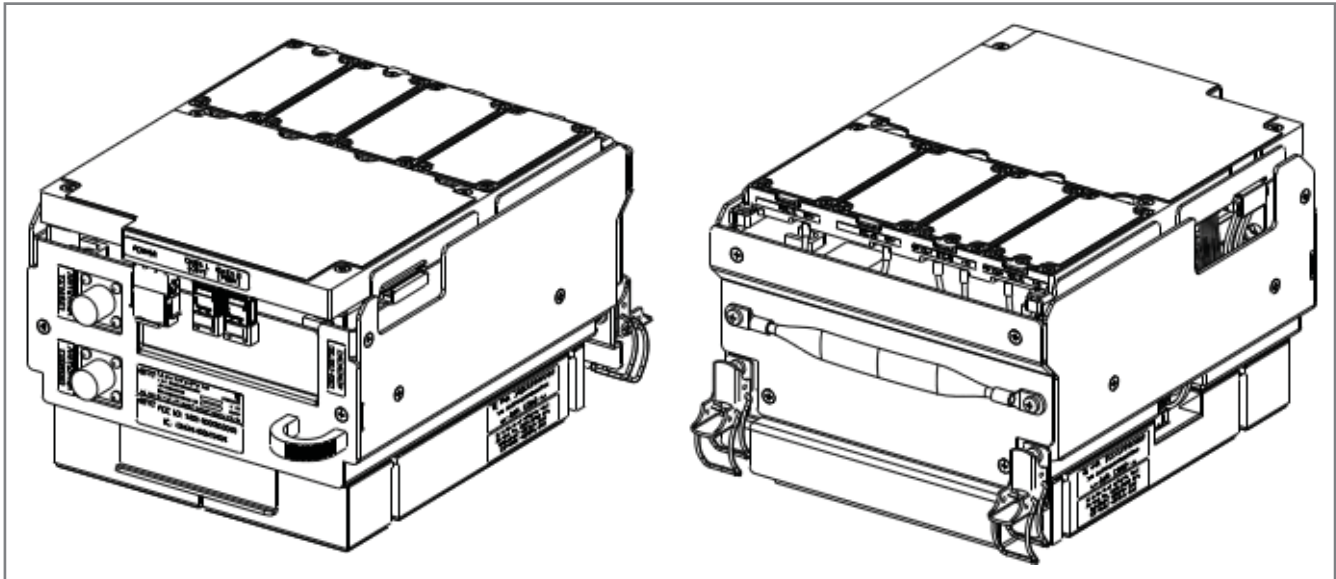

Figure 3. HDM RF Modules

An HDM RF Module does the following:

- interfaces with one Host DART-either Classic or SuperDART, or one CDIU
- supports two non-contiguous RF slices up to 35 MHz total bandwidth in a Dual or MIMO configuration
- supports full bandwidth in a SISO configuration, up to 75 MHz
- supports 20W per band/Path in a Dual/MIMO RF Module
- supports up to 40W RF output power in a SISO RF Module.

The components of a PRU HDM RF Module are dependent on the module type, as listed in [Table 12](#).

Table 12. Components of PRU HDM RF Modules

RF Module Type	DPM	LPA	Duplexer	LNA	Power Detector	Rx Card	Tx Card
SISO	1	1	1	1	1	1	1
MIMO/Dual Band Module	1	2	2	2	2	2	2

Legacy Dual-Bay 40W RF Modules

The Legacy Dual-Bay 40W RF Module ([Figure 5](#)) is designed for AWS and PCS frequencies and is supported only by Classic DARTs. The Legacy Dual-Bay 40W RF Module comprises:

- one Classic DART
- one Duplexer that comprises
 - one Low Noise Amplifier (LNA)
 - one Power Detector (PD)
- two Power Amplifiers (PAs)
- one Remote DART Interface (RDI) board.

NOTE: This manual describes how to install the PCS 1900 and AWS 2100 Non-Diversity RF Modules.

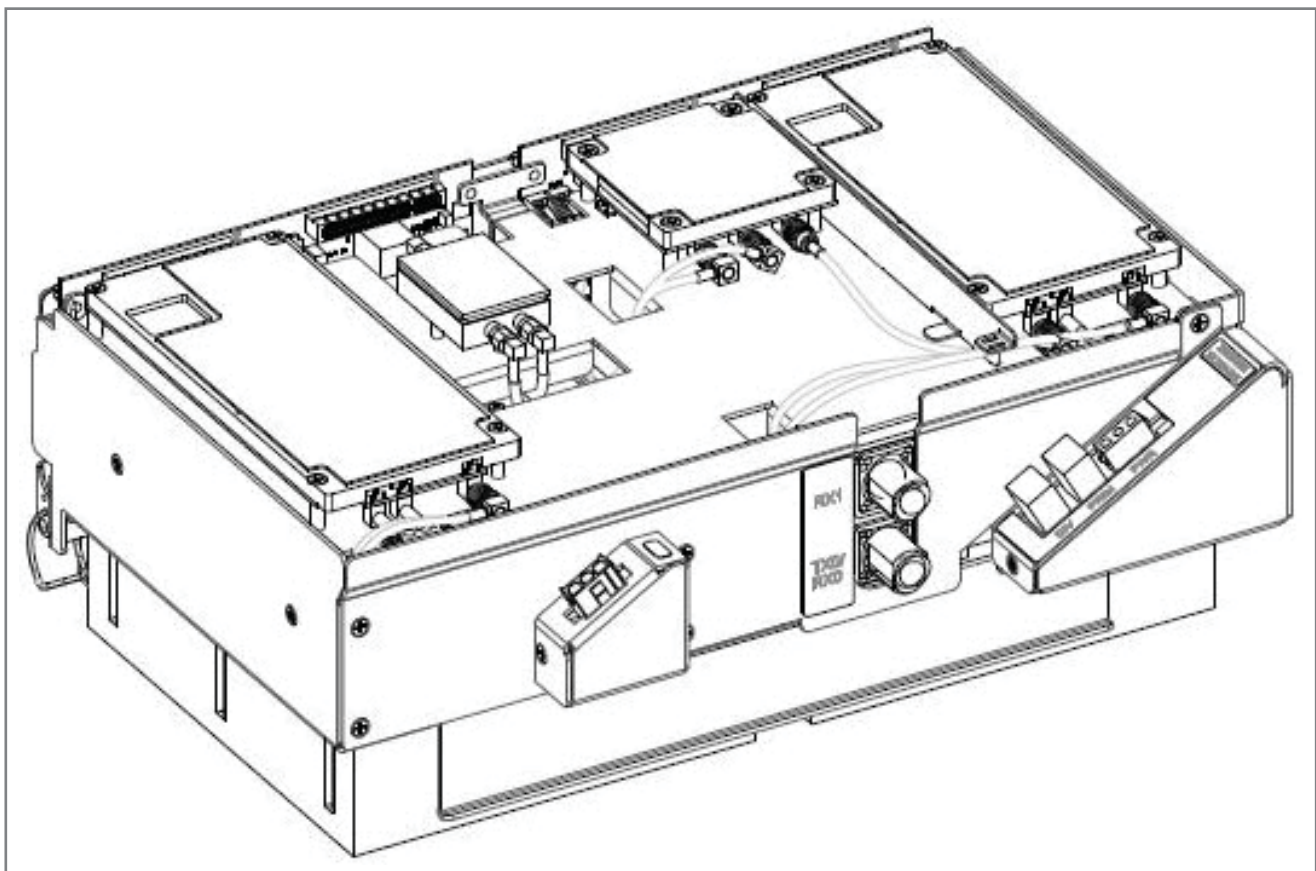

Figure 4. Legacy Dual-Bay 40W RF Module

RF MODULE COMPONENTS

Figure 5 shows typical RF Module components, using the Single-Bay RF Module as an example, and Figure 6 shows the components of an HDM RF Module.

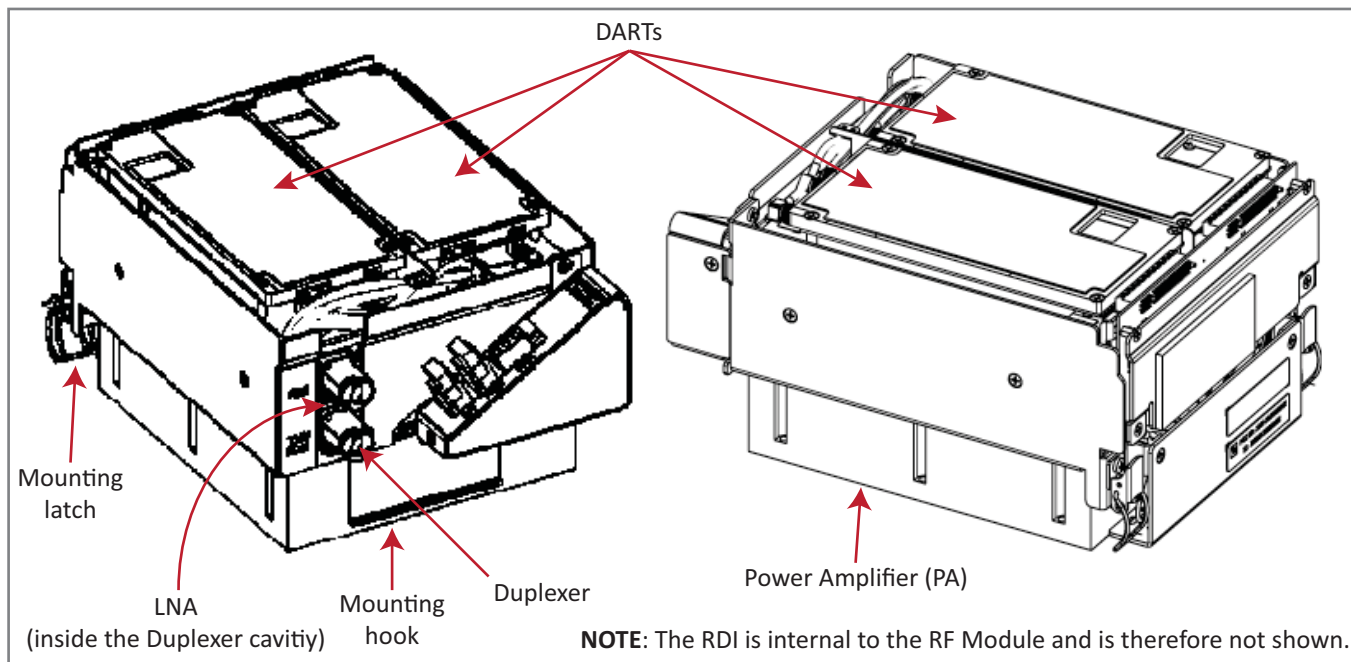

Figure 5. Single-Bay RF Module Components

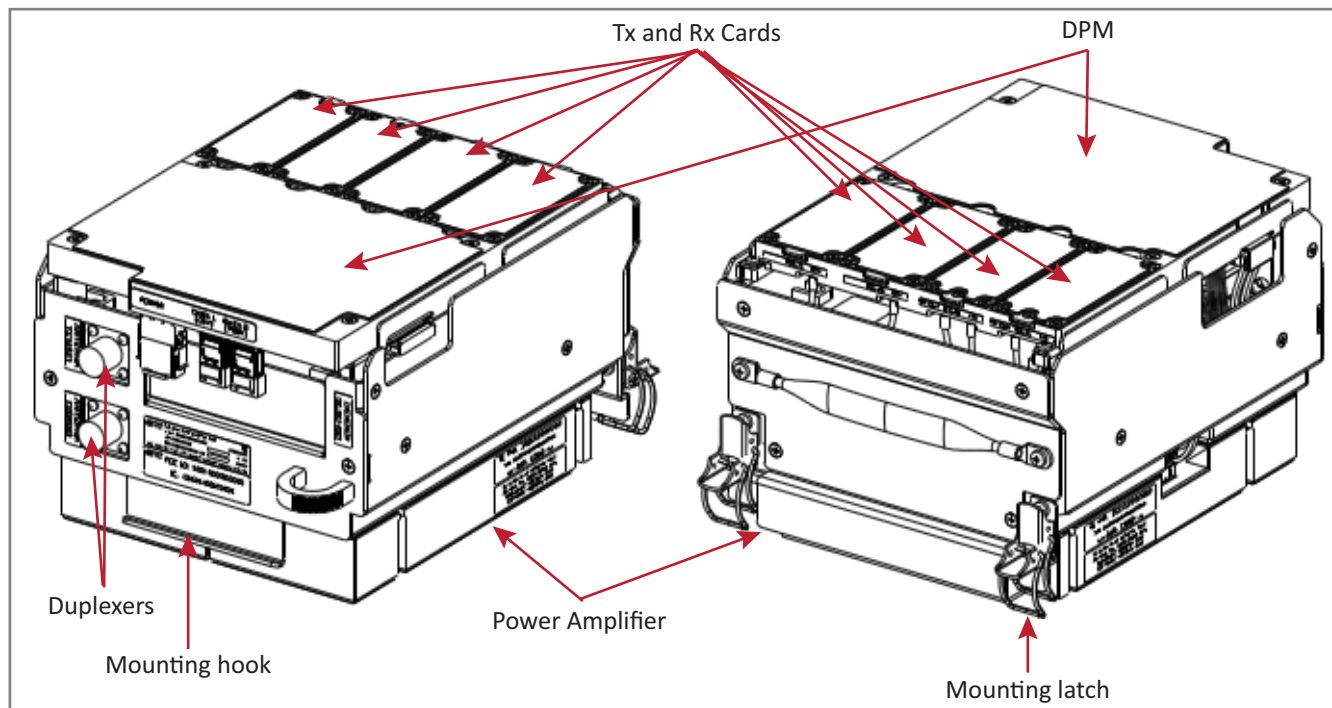

Figure 6. HDM RF Module Components

Linear Power Amplifiers

The Linear Power Amplifier (LPA) is a high quality broadband RF amplifier used for achieving Prism product-rated power for the Remote Unit Tx forward path RF. The PAs are pass-band specific, with the maximum composite Tx power levels listed in [Table 13](#) for Single-Card, Dual-Card, and HDM RF Modules and [Table 14](#) on [page 19](#) for Legacy Dual-Bay 40W RF Modules. The LPA is housed within the RF Module, and is not field serviceable.

Table 13. LPA Maximum Composite Tx Power Levels for Single-Card, Dual-Card, and HDM RF Modules

Passband	Maximum dBm	Watts	Bandwidth (MHz) supported across entire spectrum*				
			HDM		Single SuperDART	Classic DART	Dual SuperDART
			Dual/MIMO	SISO			
700 LTE Lower ABC	43	20	18	18	18	NA	NA
700 LTE Upper C	43	20	10	10	10	NA	NA
	46	40	10	10	10	NA	NA
800 SMR	43	20	7	7	NA	18	NA
850 Cellular	43	20	25	25	NA	25	NA
	46	40	25	25	NA	25	NA
900 EGSM	40	10	35	35	35	NA	NA
900 PGSM	40	10	25	25	25	NA	NA
900 SMR	38	6.5	NA	NA	NA	5	NA
1800 DCS	42	15.8	35	NA	35	NA	75
1900 PCS	43	20	35	65	35	NA	70
	46	40	NA	65	35	NA	70
2100 AWS	43	20	35	45	35	NA	45
	46	40	NA	45	35	NA	45
2100 AWS-3	43	20	35	NA	70	NA	70
2100 UMTS	42	15.8	35	NA	35	NA	60
2300 WCS	43	20	10	10	10	NA	NA
2500 TDD Low	43	20	35	NA	35	NA	NA
2500 TDD High	43	20	NA	75	75	NA	75

* The International bands (1800 DCS, 2100 UMTS, 2600 MIMO) Dual/MIMO RF Modules only support 35 MHz contiguous, as opposed to 35 MHz non-contiguous for PCS and AWS Dual/MIMO RF Modules.

Table 14. LPA Maximum Composite Tx Power Levels for Legacy Dual-Bay 40W RF Modules

Passband	Maximum dBm	Watts	Bandwidth (MHz) supported across entire spectrum Classic DART
PCS 1900	+46	40	35
AWS 2100	+46	40	35

NOTE: Industry Canada 20 dB Pass Band Model Number FWP-C4MT000MOD Cellular 850 MHz = 26.3 MHz and the PCS 1900 = 66.8 MHz.

Duplexer and Low Noise Amplifier

The RF Module provides the Remote Unit with an internal Duplexer that is optimized to provide the desired RF band-pass filtering and in-band equipment isolation between FWD and REV paths. The Duplexer provides the filtering necessary to the transmit and receive paths to and from the connected antenna.

The Duplexer for the Single- and Dual-Bay RF Modules and the Legacy Dual-Bay 40W RF Modules contains up to two REV path Low Noise Amplifiers (LNA for PRI and/or SEC reverse paths).

The Duplexer for an HDM RF Module does not have a Low Noise Amplifier.

Duplexers are not field serviceable.

Digital Processing Module

The Digital Processing Module (DPM) is found only in the HDM RF Modules. The DPM provides the primary processing and logic functions for the HDM RF Module. It also provides the primary power interface for the HDM RF Module, and conversion of the native 28 Vdc voltage to lower voltages as necessary for functionality.

The DPM has a Transmit (Tx) Board and a Receive (Rx) Board:

- Tx Board—provides band specific filtering for the intended Transmit path.
- Rx Board—provides band specific filtering for the intended Receive path.

Cables

Always provided at each RF Module shelf are five cables:

- two High-Speed Data Cables, which in this document are referred to as LVDS (Low-Voltage Differential Signaling) cables
- two RF Cables (TX0/RX0) and (TX1/RX1)
- one Power (PWR) Cable.

The RF Module cables that are pre-installed in the PRU connect to the corresponding connectors on the RF Module. The RF Module cables correlate to the antenna connectors on the bottom of the Remote Unit chassis.

LEDS on Narrowband HDM RF Modules

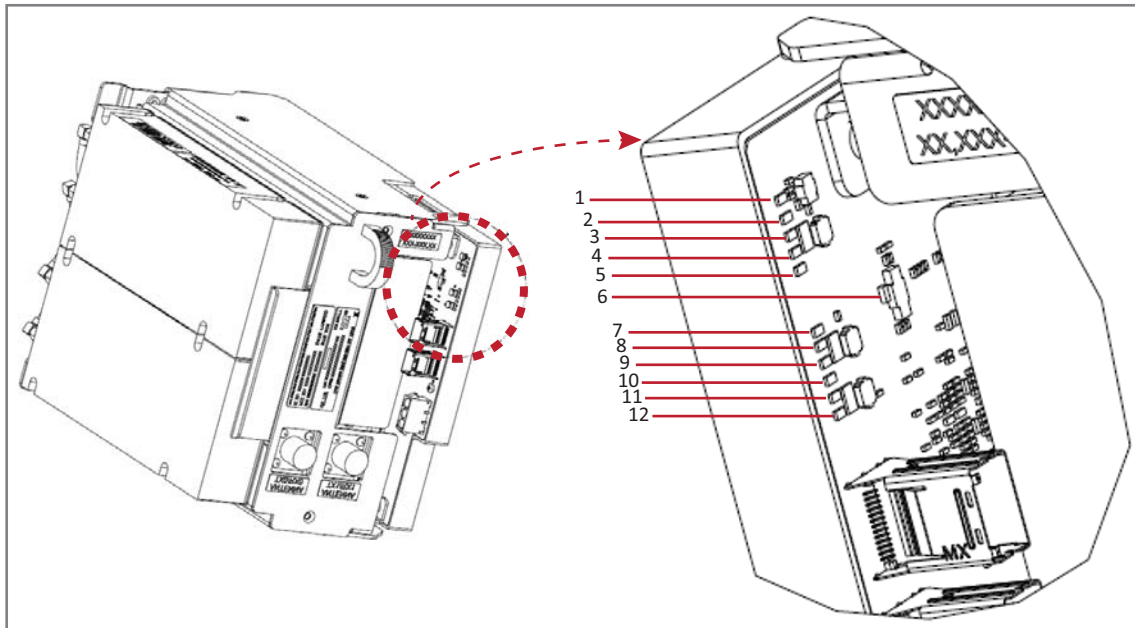

Ref #	LED	LED Color	Description
1	DPM Power	Green	HDM RF Module is powered on.
		Red	Problem with the HDM RF Module power.
2	FPGA Status	Blinking Green	Blinks as heartbeat of the HDM RF Module.
3	LVDS 0 Status	Green	Primary LVDS Dynamic Phase Alignment (DPA) connector is operating as expected.*
		Red	Primary LVDS DPA connector is not operating as expected.
4	LVDS 1 Status	Green	Primary LVDS Dynamic Phase Alignment (DPA) connector is operating as expected.*
		Red	Primary LVDS DPA connector is not operating as expected.
5	DSP/GC Status	—	Not used.
6	FPGA Load Status	Red	FPGA is in startup mode.
		Off	FPGA load is complete.
7	TXA Status	Green	All synthesizers are locked.
		Blinking Green	One or more synthesizer is unlocked.
		Red	Overflow on RX.
8	RXA Status	Green	All synthesizers are locked.
		Blinking Green	One or more synthesizer is unlocked.
		Red	Overflow on RX.
9	TMA A Status	—	Not used.
10	TXB Status	Green	All synthesizers are locked.
		Blinking Green	One or more synthesizer is unlocked.
		Red	Overflow on RX.
11	RXB Status	Green	All synthesizers are locked.
		Blinking Green	One or more synthesizer is unlocked.
		Red	Overflow on RX.
12	TMA A Status	—	Not used.

1 LED is only applicable to the Primary connector; it is not tied to the status of the Secondary DPA connector.

LEDS on Wideband and Fullband HDM RF Modules

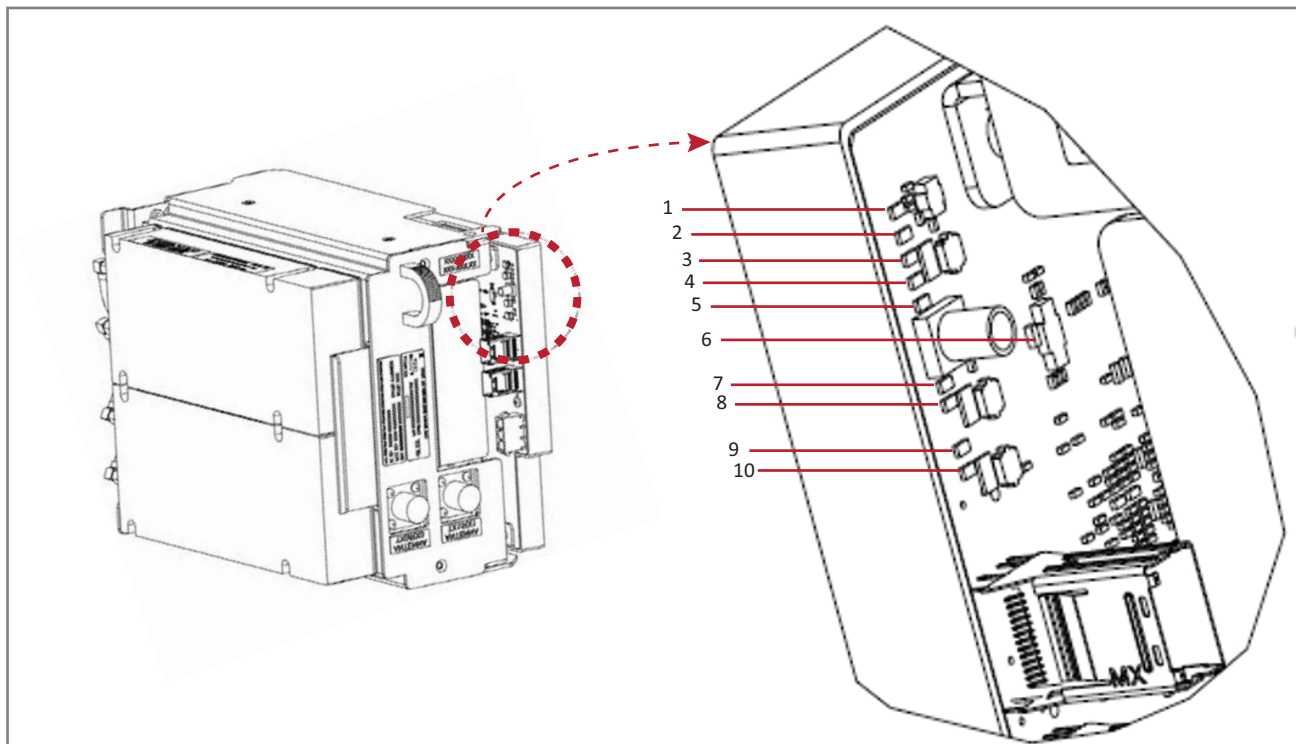

Ref #	LED	LED Color	Description
1	DPM Power	Green	HDM RF Module is powered on.
		Red	Problem with the HDM RF Module power.
2	FPGA Status	—	Not used.
3	LVDS 0 Status	—	Not used.
4	LVDS 1 Status	—	Not used.
5	DSP/GC Status	—	Not used.
6	FPGA Load Status	Red	FPGA is in startup mode.
		Off	FPGA load is complete.
7	TXA Status	Green	All synthesizers are locked.
		Blinking Green	One or more synthesizer is unlocked.
		Red	Overflow on RX.
8	RXA Status	Green	All synthesizers are locked.
		Blinking Green	One or more synthesizer is unlocked.
		Red	Overflow on RX.
9	TXB Status	Green	All synthesizers are locked.
		Blinking Green	One or more synthesizer is unlocked.
		Red	Overflow on RX.
10	RXB Status	Green	All synthesizers are locked.
		Blinking Green	One or more synthesizer is unlocked.
		Red	Overflow on RX.

CONFIGURING THE SYSTEM WITH RF

The following sections describe how to correctly pair RF Modules with PRU slots, cables, and Antenna connectors.

RF GROUP ASSIGNMENTS FOR PRU RF MODULE BAYS

A PRU comprises from one to four RF Module bays. [Figure 7](#) illustrates the numbering of RF Module bays and DARTs.

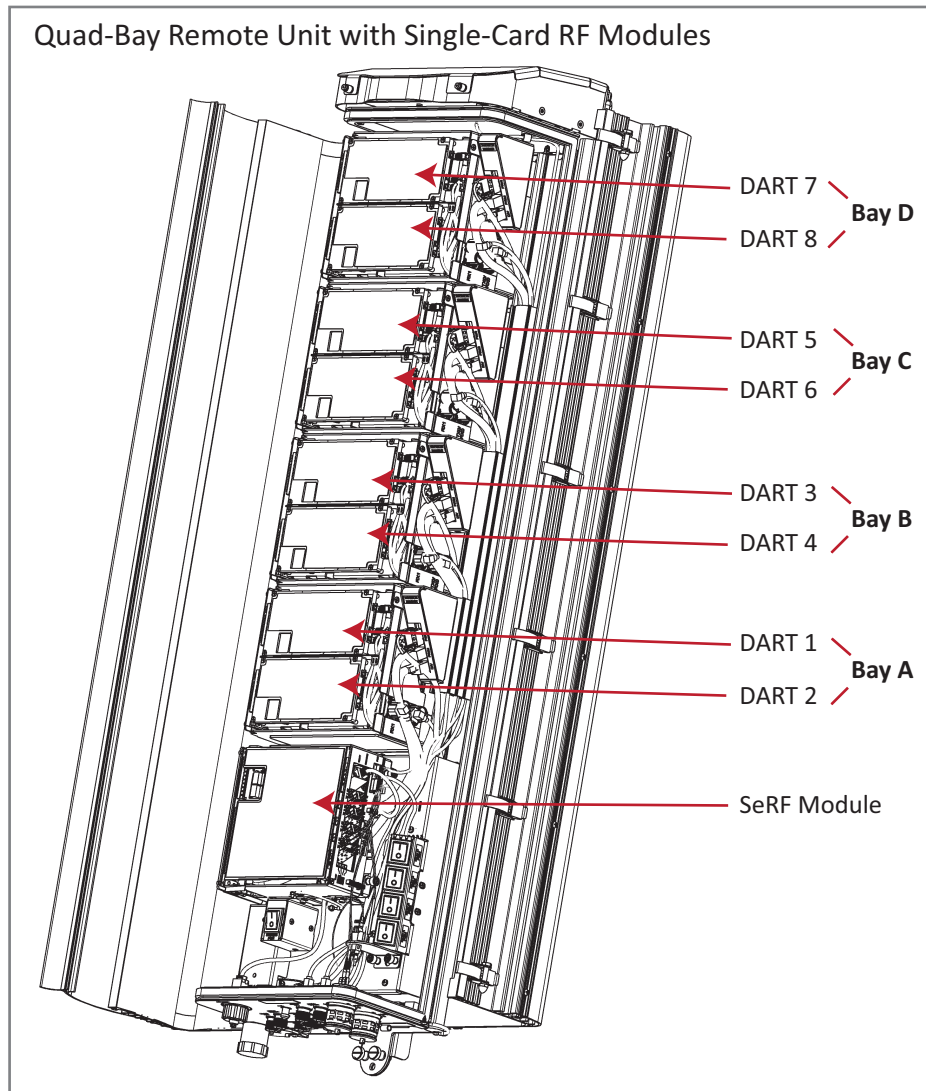

Figure 7. RF Modules Bays in a PRU

Table 15 lists how the FlexWave Prism EMS references the RF group assignments and corresponding components of each RF Module.

Table 15. Remote Unit RF Group Assignments (from Top/Down)

Physical RF Bay	DART Number	LNA Number		LPA Number for Single LPA	LPA Number for Dual LPAs	Power Detector Number for Single PD	Power Detector Number for Dual PDs
		Primary	Diversity				
D	8		8	7	8	7	8
	7	7			7		7
C	6		6	5	6	5	6
	5	5			5		5
B	4		4	3	4	3	4
	3	3			3		3
A	2		2	1	2	1	2
	1	1			1		1

NOTE: For software releases prior to 7.3, the LPAs were labeled as 1, 2, 3, and 4.

NOTE: For Classic dual position 40W RF Modules only: in a dual LPA system, the Configure Remote Forward Gain page shows two values for the LPA status, one for each LPA. Changing the LPA Mode or resetting the LPA applies to both LPAs at the same time.

CAUTION! Should your system experience an LPA problem, refer to Table 15 to ensure that you apply new settings or troubleshoot the correct RF Module.

The Legacy Dual-Bay 40W RF Module occupies two bays in a PRU. Figure 8 on page 25 shows the main components in a PRU enclosure, with a Legacy 40W RF Module occupying Bays A and B. The controlling DART will always be in the upper bay (B or D), and the second LPA is always in the lower bay (A or C).

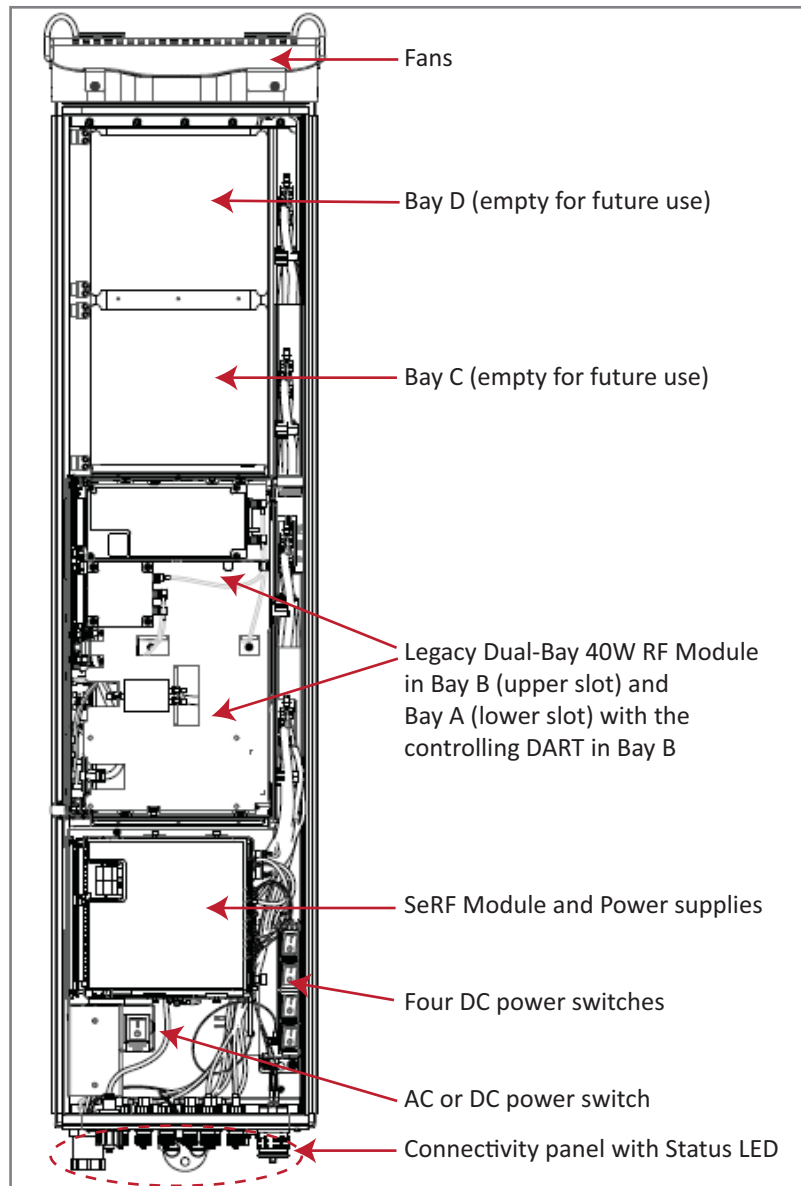

Figure 8. Legacy Dual-Bay 40W RF Module in a Quad-Bay PRU

NOTE: If a Legacy Dual-Bay 40W RF Module AWS 2100 and a Legacy Dual-Bay 40W RF Module PCS 1900 are both installed in a Quad-Bay PRU, it is recommended that the PCS 1900 be installed in upper-most bay, and the AWS 2100 be installed in the lower-most bay.

NOTE: To accommodate two-bay modules, you need to remove a module bay shelf as described in "[Dual-Bay Modules Only—Remove the Module Bay Shelf](#)" on page 89.

UNDERSTANDING RF CABLE RULES



CAUTION! To avoid the risk of equipment damage, ensure that the AC/DC Power switch to the PRU chassis and all RF Module DC power switches are in their OFF position before connecting or disconnecting coaxial cables; otherwise equipment damage may occur.

- When installing a Diversity, MIMO or Dual-Band RF Module, both RF cables labeled MOD N TX0/RX0 and MOD N TX1/RX1 shall be connected to the N-Style connections of the RF Module. Note that older labeling schemes used “PRI” and “DIV”. To match old labeling schemes to current labeling:

Old Label	New Label
PRI	TX0/RX0
DIV	TX1/RX1

- When installing a Non-Diversity or SISO RF Module, or an SMR 800/900 Dual-Band Dual-Bay RF Module:
 - Connect the MOD N TX0/RX0 cable to the single available N-Style RF Connection of the RF Module.
 - Constrain the MOD N TX1/RX1 cable with the existing cables using a tie wrap or similarly accepted fastener so it cannot be pinched or prevent the Remote Unit door from closing. Do not cut or attempt to otherwise remove this RF Cable.
- RF cables are hand-malleable; however, cables must adhere to a minimum bend radius of 1-inch from the outlet of the integrated cable guide to the respective N-Style RF connection on the RF Module.

RF Module Cables and Supported Bay Use for Single-Card, Dual-Card, and HDM RF Modules

The RF cable and connector labels correspond to the RF Module bays in the Remote Unit chassis, where **MOD A** is the bottom bay and **MOD D** is the top bay.

- The cables and connectors have corresponding labels as shown in [Table 16 on page 27](#) for Single-Card, Dual-Card, and HDM RF Modules. For Dual-Bay installations, the RF cables and connectors are labeled as **MOD N TX0/RX0** and **MOD N TX1/RX1**, where **N** refers to the top bay of the double-bay installation. For example:
 - For a Dual-Bay installation in a Quad-Bay chassis in which the RF Module is installed in the Bay D and Bay C combination, the RF cables and connectors are labeled as **MOD D TX0/RX0** and **MOD D TX1/RX1**.
 - For a Dual-Bay installation in a Tri-Bay chassis in which the RF Module is installed in the Bay B and Bay A combination, the RF cables and connectors are labeled as **MOD B TX0/RX0** and **MOD B TX1/RX1**.
- [Table 16 on page 27](#) also shows which RF Module type can be installed in which PRU bay or bay combination.

Table 16. Supported Bay Use and RF Antenna Labels for Single-Card, Dual-Card, and HDM RF Modules
(From Top of Remote Unit Chassis Down)

	Supported Bay Configurations for Single-Bay RF Modules	Supported Bay Combinations for Dual-Bay RF Modules			RF Module Cable, RF Module Connector, and Remote Antenna Connector Label	Function
		Supported Bays in Dual-Bay Chassis	Supported Bays in Tri-Bay Chassis	Supported Bays in Quad-Bay Chassis		
Bay D	MOD D	N/A	N/A	MOD D	Mod D TX0/RX0	Transmit RF power and primary/Path 1 receive to/from the antenna for RF Module D
					Mod D TX1/RX1	Transmit RF power and secondary/Path 2 receive to/from the antenna for RF Module D
Bay C	MOD C	N/A	MOD C		Mod C TX0/RX0	Transmit RF power and primary/Path 1 receive to/from the antenna for RF Module C
					Mod C TX1/RX1	Diversity receive/Path 2 for Transmit RF power and secondary/Path 2 receive to/from the antenna for RF Module C
Bay B	MOD B	MOD B	MOD B	MOD B	Mod B TX0/RX0	Transmit RF power and primary/Path 1 receive to/from the antenna for RF Module B
Bay A	MOD A				Mod B TX1/RX1	Transmit RF power and secondary/Path 2 receive to/from the antenna for RF Module B
		Mod A TX0/RX0	Transmit RF power and primary/Path 1 receive to/from the antenna for RF Module A			
					Mod A TX1/RX1	Transmit RF power and secondary/Path 2 receive to/from the antenna for RF Module A

RF Module Cables and Supported Bay Installations for Legacy Dual-Bay 40W RF Modules

The cables and connectors have corresponding labels as shown in [Table 17 on page 28](#) for Legacy Dual-Bay 40W RF Modules. [Table 17 on page 28](#) also shows which RF Module type can be installed in which PRU bay(s) when a 40W Dual-Bay RF Module is part of the RF Module mix in a PRU chassis. The Single-Bay chassis is not included in [Table 17 on page 28](#).

For Dual-Bay installations, the RF cables and connectors are labeled as **MOD N TX0/RX0** and **MOD N TX1/RX1**, where **N** refers to the top bay of the double-bay installation. For example:

- For a Dual-Bay installation in a Quad-Bay chassis in which the RF Module is installed in the Bay D and Bay C combination, the RF cables and connectors are labeled as **MOD D TX0/RX0** and **MOD D TX1/RX1**.
- For a Dual-Bay installation in a Tri-Bay chassis in which the RF Module is installed in the Bay C and Bay B combination, the RF cables and connectors are labeled as **MOD C TX0/RX0** and **MOD C TX1/RX1**.

Table 17. Supported Bay Assignments and RF Antenna Labels for Legacy Dual-Bay 40W RF Modules (From Top of Remote Unit Chassis Down)

	Supported Bay Combinations for Legacy 40W Dual-Bay RF Modules						RF Module Cable, RF Module Connector, and Remote Antenna Connector Label	Function
	Dual-Bay	Tri-Bay	Tri-Bay	Quad-Bay				
Bay D	N/A	N/A	N/A	MOD D	MOD D	MOD C	Mod D TX0/RX0	Transmit RF power and primary/Path 1 receive to/from the antenna for RF Module D
							Mod D TX1/RX1	Transmit RF power and secondary/Path 2 receive to/from the antenna for RF Module D
Bay C	N/A	MOD C	MOD C	MOD D	MOD C	MOD C	Mod C TX0/RX0	Transmit RF power and primary/Path 1 receive to/from the antenna for RF Module C
							Mod C TX1/RX1	Transmit RF power and secondary/Path 2 receive to/from the antenna for RF Module C
Bay B	MOD B	MOD B	MOD C	MOD B	MOD B	MOD B	Mod B TX0/RX0	Transmit RF power and primary/Path 1 receive to/from the antenna for RF Module B
							Mod B TX1/RX1	Transmit RF power and secondary/Path 2 receive to/from the antenna for RF Module B
Bay A	MOD B	MOD B	MOD A	MOD B	MOD B	MOD A	Mod A TX0/RX0	Transmit RF power and primary/Path 1 receive to/from the antenna for RF Module A
							Mod A TX1/RX1	Transmit RF power and secondary/Path 2 receive to/from the antenna for RF Module A

NOTE: For Dual Module installations, the center module shelf needs to be removed; see ["Dual-Bay Modules Only—Remove the Module Bay Shelf"](#) on page 89.

NOTE: Install the Legacy Dual-Bay 40W RF Module in the lower-most bay in the chassis. If, however, if two Legacy Dual-Bay 40W RF Modules are present, install the 2100 Module in the lower-most Bay and the 1900 Module in the upper-most Bay.