



**Test Report Summary**  
**FCC CFR 47, Part 22**  
**Subpart H Cellular Radiotelephone Service**  
**FCC CFR 47, Part 24**  
**Subpart E Broadband PCS**

**Manufacturer:** ADC Telecommunications, Inc

**Name of Equipment:** FlexWave™ Prism – HDM 850/1900 MHz RF Module

**Model Number(s):** FWP-C41T000MOD

**Manufacturer's Address:** P.O. Box 1101  
Minneapolis, MN 55440-1101

**Test Report Number:** MN121114 FCC Prism HDM 850/1900  
FCC-ID: F8I-PSM8192D

**Test Date(s):** 26 October, 2012 (Intertek)  
25, 30, 31 October & 1, 2, 6, 7, 8 November  
(ADC)

According to testing performed at Intertek, the above-mentioned unit is in accordance with the applicable electromagnetic compatibility (EMC) portions of the requirements defined in FCC Part 22 and 24.

It is the manufacturer's responsibility to assure that additional production units of this model are manufactured with identical electrical and mechanical characteristics. Any modifications necessary for compliance made during testing on the above mentioned date(s) must be implemented in all production units for compliance to be maintained.

All testing was done in accordance with the Federal Communications Commission's CFR 47 Part 22 and 24. The EUT fulfills the requirements of the Federal Communications Commission's CFR 47 Part 22 and 24.

Date: 14 November, 2012

Location: Intertek Testing Services (INTERTEK)  
7250 Hudson Blvd., Suite 100  
Oakdale, MN 55128  
Phone: (651) 730-1188  
Fax: (651) 730-1282

ADC Telecommunications  
1187 Park Place  
Shakopee, MN 55379  
Phone: (952) 403-8322

Testing Conducted by (ADC):  
And Report Written by:

  
Joshua J. Wittman  
Compliance Engineer





## 1.0 TABLE OF CONTENTS

1.0	Table of Contents.....	3
2.0	Revision Description.....	4
3.0	Documentation.....	4
3.1	Test Regulations.....	4
3.2	Summary:.....	5
3.3	Test Operation Mode.....	5
3.4	Configuration of the Device Under Test:.....	5
3.5	Product Options:.....	5
3.6	EUT Specifications and Requirements:.....	5
3.7	Cables:.....	5
3.8	Power Requirements:.....	6
3.9	Typical Installation and/or Operating Environment:.....	6
3.10	Other Special Requirements:.....	6
3.11	EUT Software:.....	6
3.12	EUT System Components.....	6
3.13	Deviations from Standard:.....	6
3.14	General Remarks:.....	7
4.0	Test Set-Up Drawings and Photos.....	8
4.1	Test Set-up Photo, Radiated Emissions.....	8
4.2	Test Set-up Drawings.....	9
5.0	Test Equipment.....	11
6.0	Test Results.....	12
6.1	FCC 22.917 & 24.238 Emissions Limits – Band Edge.....	12
6.2	FCC 2.1049, 22.917, & 24.238 – Occupied Bandwidth.....	28
6.3	FCC 2.1046, 22.913, & 24.232 Power Limits – Output Power.....	44
6.4	FCC 2.1051, 22.917, & 24.238 Emissions Limits – Spurious Emissions at Antenna.....	47
6.5	FCC 2.1055, 22.355, & 24.235 – Frequency Stability.....	154
7.0	Appendix B.....	157
8.0	Appendix C.....	159



## 2.0 REVISION DESCRIPTION

Rev	Total Pages	Date	Description
A	159	14 November, 2012	Original Release

## 3.0 DOCUMENTATION

### 3.1 Test Regulations

The emissions tests were performed according to the following regulations:

- FCC Part 22
- FCC Part 24

<u>FCC Section</u>	<u>Test</u>	<u>Results</u>
22.355	Frequency Stability	Pass
22.913	Effective Radiated Power Limits	Pass
22.917	Emissions Limits for Cellular	Pass
24.235	Frequency Stability	Pass
24.232	Effective Radiated Power Limits	Pass
24.238	Emissions Limits for PCS	Pass

### 3.2 Summary:

The requirements according to the technical regulations are

- **met**
- not Met

The equipment under test does

- **fulfill the general approval requirements mentioned in Section 3.1.**
- not fulfill the general approval requirements mentioned in Section 3.1.

### 3.3 Test Operation Mode

- Standby
- Test Program
- Practice Operation
- **Max composite in and out**

### 3.4 Configuration of the Device Under Test:

Normal Operation – Cellular - 869 to 894 MHz

Normal Operation – PCS - 1930 to 1995 MHz

### 3.5 Product Options:

None

### 3.6 EUT Specifications and Requirements:

Length: 10.0"

Width: 12.0"

Height: 40.0"

Weight: 150 pounds

### 3.7 Cables:

Cable Type	Length	From	To
RF	> 3M	Ancillary Equip	EUT
RF	< 3M	EUT	50 Ohm Load
Power	< 3M	Power	Input Power
Fiber	> 3M	Ancillary Equip	EUT

**3.8 Power Requirements:**

Voltage: 120 VAC

Amps: 5.8 A

**Power Supply Utilized:**

Power Supply System : 120 VAC, Single Phase

**3.9 Typical Installation and/or Operating Environment:**

Outdoor/Indoor - System is typically employed as an outdoor repeater.

**3.10 Other Special Requirements:**

None

**3.11 EUT Software:**

Revision Level: Version V.6 or greater

Description: Internet Explorer

**3.12 EUT System Components**

Description	Model #	Serial #	FCC ID #
Prism Chassis	FP3-0000000000000111	None	
HDM 850/1900 RF Module	FWP-C41T000MOD	None	

**3.13 Deviations from Standard:**

Modifications required to pass:

As indicated on the data sheet(s)

**None**

Test Specification Deviations; Additions to or Exclusions from:

As indicated in the Test Plan

**None**

### 3.14 General Remarks:

The Host unit connects directly to the BTS via coax. The Host unit does not connect to an antenna or amplifier, thus it is a Part 15 device and has been tested and is compliant as such. No FCC ID is necessary.

Industry practice has generally set the input signal power level. Test signal used was  $\approx -25$  dBm input to DHU. Industry practice has generally set the output signal power level.

Prism Remote:

Range: 100 - 240 VAC

Tested @: 120 VAC

Tested @: 5.8 A

Digital Host Unit (DHU):

Range: 21-60 VDC

Tested @: 48 VDC

Tested @: 3.5 A

Application details for 2.1033(c)(8), 2.1033(c)(10), and 2.1033(c)(13):

RF amplifier output stage has three devices with 27.5 VDC voltage applied. Current for device #1 is 3.5A max. Devices #2 and #3 have 1.5A max.

The input to the host unit has a digital attenuation chip (ALC) to provide protection from overdrive with 5-10 millisecond attack time / 100 millisecond decay time and 31 dB of head room, such that single channel operation, or multi-channel operation will not exceed nominal gain of the system.

The frequency stability is derived by the BTS, base transceiver station. This product uses internal frequency stability to keep the signal inside our filter bandwidths. This means that the frequency can change, but the frequency that transmits is still at the original frequency. The remote system uses the data over the fiber optic path to phase/frequency lock to the host. The purpose is to frequency lock the up- and down-conversion local oscillators, and thereby eliminate any end-to-end frequency shift.

The spurious limitation is completed with the duplexer. The ALC also suppresses in-band spurious by preventing PA overdrive, while the duplexer suppresses out-of-band spurious. Internal to the electronics, the use of SAW filters provides for higher Q roll-off at band edges.

This equipment does not modulate the RF, so there is no modulation limiter. This equipment does not change the modulation of the RF or the occupied bandwidth of any channel. It transports the signal, as is, over an optical link. The RF input is not changed in the RF output.

This is a constant gain device, so the setup controls the output. There is an overdrive and overpower limit control that prevents excess power.

## **4.0 TEST SET-UP DRAWINGS AND PHOTOS**

[Table of Contents; Section 1.0](#)

### **4.1 Test Set-up Photo, Radiated Emissions**

Reference Intertek Report 100913866MIN-001



## 4.2 Test Set-up Drawings

### Band Edge Test

### Output Power Test

### Spurious Emission Test

### Occupied Bandwidth Test

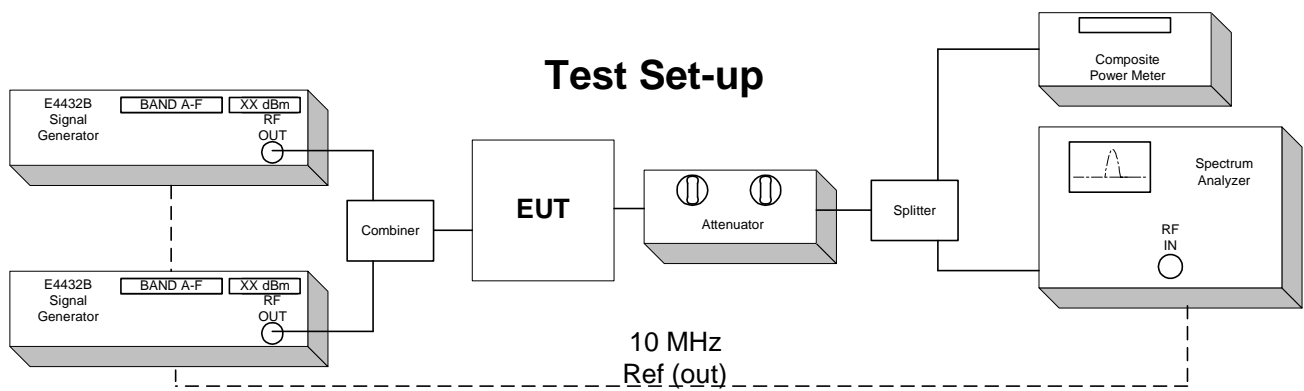

# Frequency Tolerance Test

EUT is specified for outdoor use with temperature range of  $-30^{\circ}$  to  $+50^{\circ}$  C, and was tested with its range.

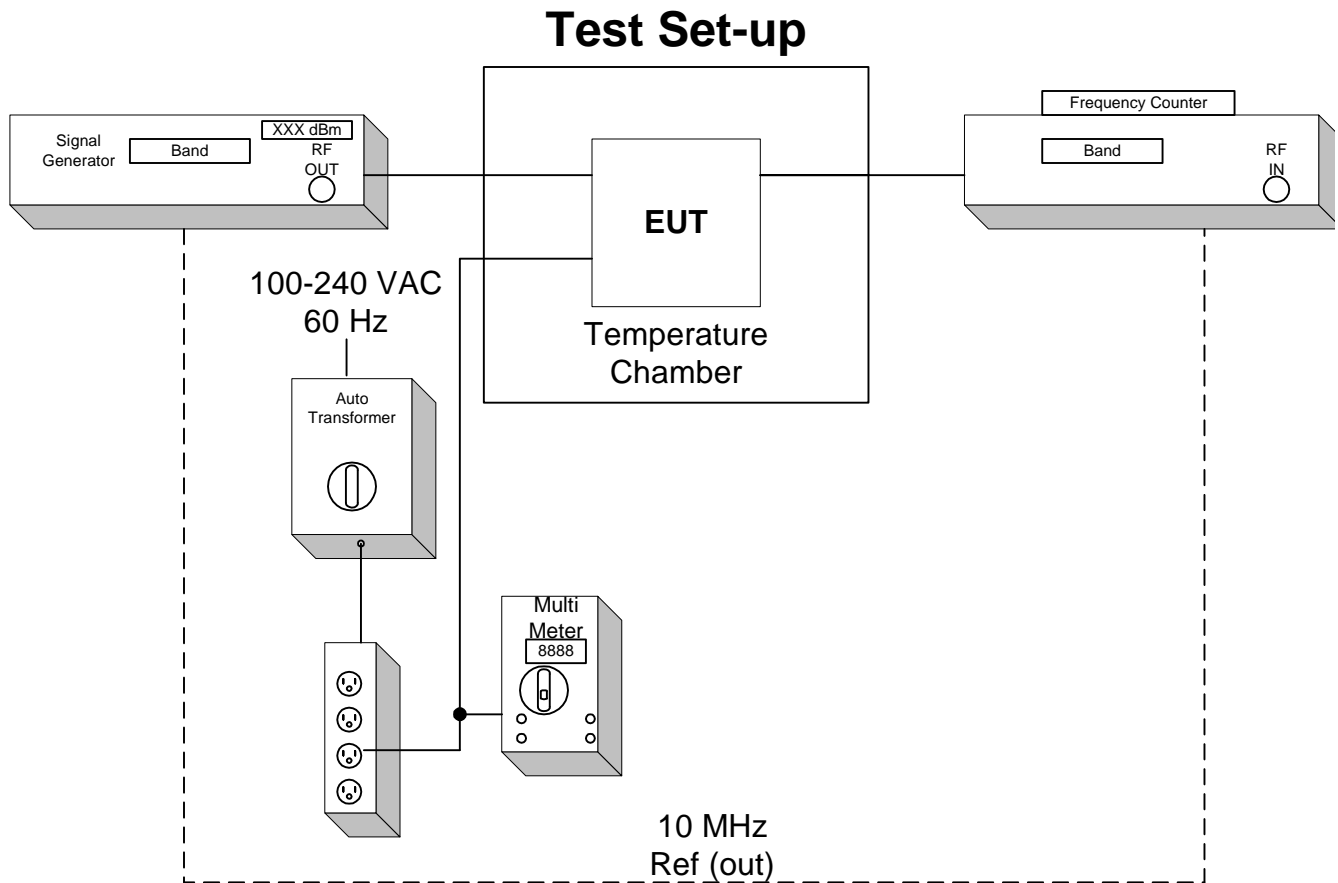

## 5.0 TEST EQUIPMENT

### [Table of Contents; Section 1.0](#)

Number	Description	Manufacturer	Model	ADC TELECOMMUNICATIONS Serial Number	Cal Due	Used
1	Spectrum Analyzer	HP	8563E	MC27690	6-30-13	<input checked="" type="checkbox"/>
2	Power Meter	HP	437B	MC27754	6-30-13	<input checked="" type="checkbox"/>
3	Multimeter	Fluke	79	MC16178	10-11-13	<input checked="" type="checkbox"/>
4	Frequency Counter	HP	5347A	MC27569	6-30-13	<input checked="" type="checkbox"/>
5	Temperature Chamber	ESPEC	PSL-4G	MC10075	9-10-13	<input checked="" type="checkbox"/>
6	Signal Generator	Aeroflex	3413	MC57343	2-9-13	<input checked="" type="checkbox"/>
7	Signal Generator	Aeroflex	3413	MC57947	6-26-14	<input checked="" type="checkbox"/>
8	Variable Auto Transformer	Staco	1520CT	MC44655	CNR	<input checked="" type="checkbox"/>
9	Digital Barometer	Fisher Scientific	02-403	MC50719	1-25-13	<input checked="" type="checkbox"/>
10	Attenuator	Aeroflex	49-30-33	N/A	CNR	<input checked="" type="checkbox"/>
11	Attenuator	Aeroflex	86-30-12	N/A	CNR	<input checked="" type="checkbox"/>
12	RF Power Sensor	HP	8482A	MC48747	6-30-13	<input checked="" type="checkbox"/>

Equipment with a Calibration Not Required (CNR) listing is verified and compensated for with NIST traceable calibrated equipment

## 6.0 TEST RESULTS

### 6.1 FCC 22.917 & 24.238 Emissions Limits – Band Edge

#### Test Summary:

- The requirements are:                   • **MET**                   ◦ NOT MET

#### Test Methods Used:

TIA-603-C 2004, ANSI C63.4-2003, FCC 22.917, & 24.238

#### Test Procedure:

The RF Output of the transmitter was connected to input of the spectrum analyzer through sufficient attenuation.

Band Edge compliance is demonstrated using a GSM, EDGE, CDMA, WCDMA, LTE 3 MHz, LTE 5MHz, LTE 10MHz, & LTE 15MHz Channel Bandwidths signal at the upper and lower limits of the band.

#### Test Limit:

Out of band emissions:

Attenuated below the transmitting power (P) by a factor of at least  $43 + 10\log(P)$  dB, or  $-13$  dBm.

**Test Dates: 11/1/12 & 11/2/12**

**Tests Conducted By: Joshua J. Wittman**

**Test Equipment: 1, 2, 6, 9, 12**

Number	Description	Manufacturer	Model	ADC TELECOMMUNICATIONS Serial Number	Cal Due	Used
1	Spectrum Analyzer	HP	8563E	MC27690	6-30-13	<input checked="" type="checkbox"/>
2	Power Meter	HP	437B	MC27754	6-30-13	<input checked="" type="checkbox"/>
6	Signal Generator	Aeroflex	3413	MC57343	2-9-13	<input checked="" type="checkbox"/>
9	Digital Barometer	Fisher Scientific	02-403	MC50719	1-25-13	<input checked="" type="checkbox"/>
12	RF Power Sensor	HP	8482A	MC48747	6-30-13	<input checked="" type="checkbox"/>

#### Environmental Conditions in the lab:

**Temperature:** 28° C

**Relative Humidity:** 20%

**Atmospheric Pressure:** 99.0 kPa

**Test Results:**

Band\_Edge CDMA CELL 20W  
Center: 869.75 MHz Span: 2 MHz RBW: 10 kHz VBW: 10 kHz

ATTEN 30dB VAUG 100 MKR -31.16dBm  
RL 50.2dBm 10dB/ 869.000MHz

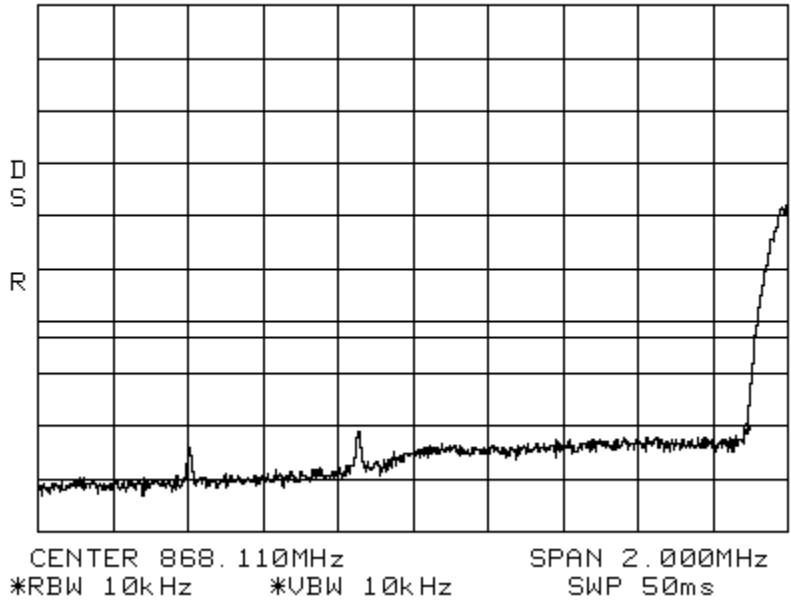

Band\_Edge CDMA CELL 20W  
Center: 893.25 MHz Span: 2 MHz RBW: 10 kHz VBW: 10 kHz

ATTEN 30dB VAUG 100 MKR -29.50dBm  
RL 50.2dBm 10dB/ 894.000MHz

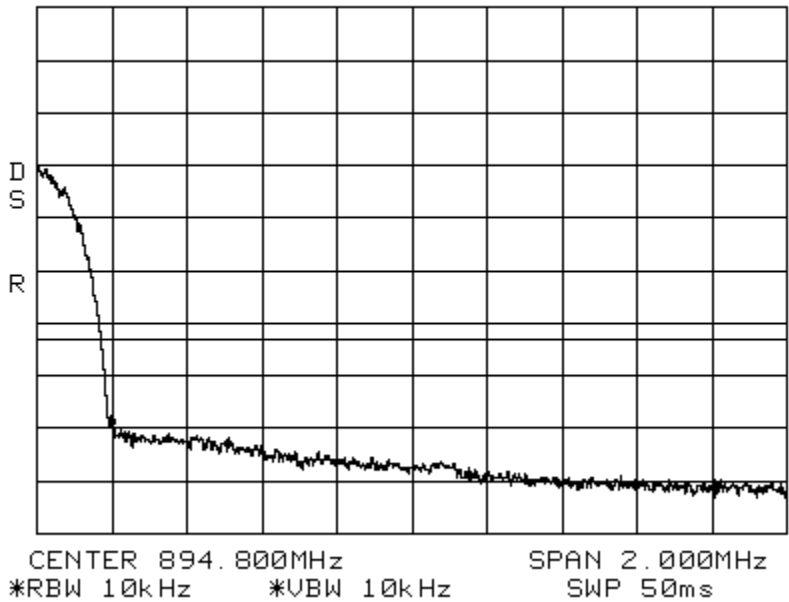

Band\_Edge EDGE CELL 20W  
Center: 869.2 MHz Span: 1.5 MHz RBW: 3 kHz VBW: 10 kHz

ATTEN 30dB VAUG 100 MKR -20.50dBm  
RL 50.2dBm 10dB/ 869.000MHz

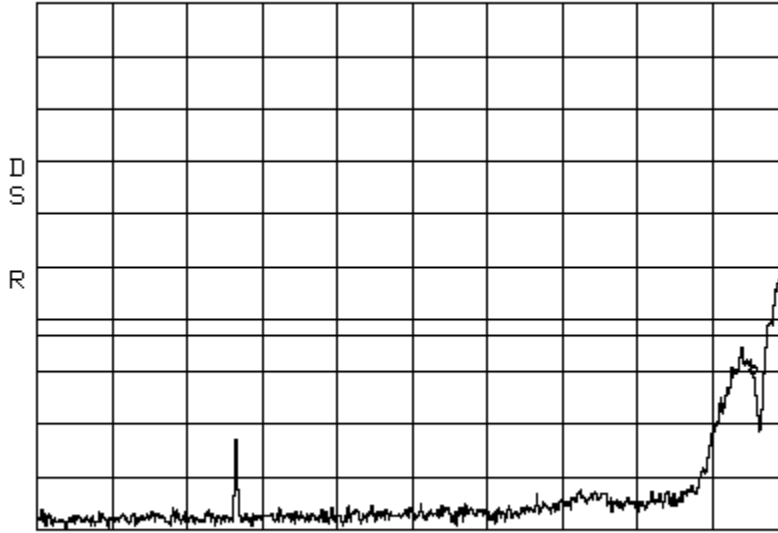

CENTER 868.318MHz SPAN 1.500MHz  
\*RBW 3.0kHz \*VBW 10kHz SWP 420ms

Band\_Edge EDGE CELL 20W  
Center: 893.8 MHz Span: 1.5 MHz RBW: 3 kHz VBW: 10 kHz

ATTEN 30dB VAUG 100 MKR -20.16dBm  
RL 50.2dBm 10dB/ 894.000MHz

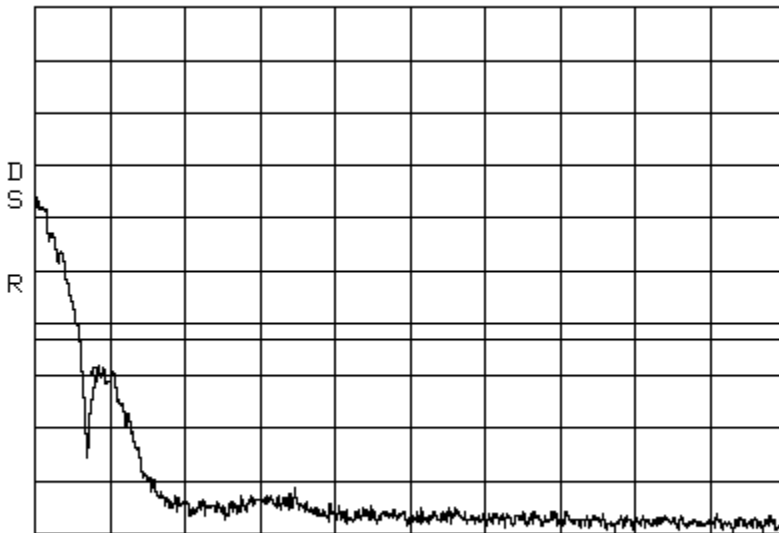

CENTER 894.630MHz SPAN 1.500MHz  
\*RBW 3.0kHz \*VBW 10kHz SWP 420ms

Band\_Edge GSM CELL 20W  
 Center: 869.2 MHz Span: 1 MHz RBW: 3 kHz VBW: 10 kHz  
 ATTN 30dB VAVG 100 MKR -24.66dBm  
 RL 50.2dBm 10dB/ 869.000MHz

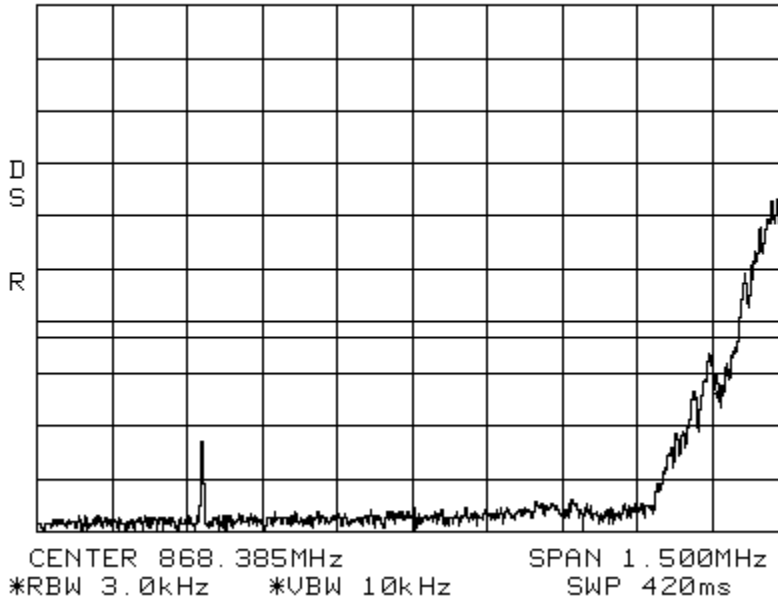

Band\_Edge GSM CELL 20W  
 Center: 893.8 MHz Span: 1 MHz RBW: 3 kHz VBW: 10 kHz  
 ATTN 30dB VAVG 100 MKR -29.33dBm  
 RL 50.2dBm 10dB/ 894.000MHz

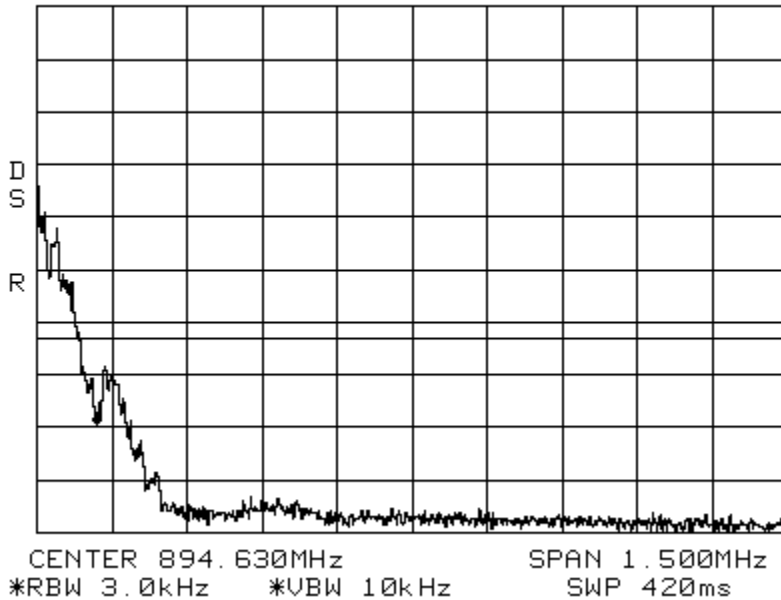

Band\_Edge                    LTE 3 MHz Channel Bandwidth                    CELL 20W  
Center: 870.5 MHz    Span: 5 MHz                    RBW: 30 kHz VBW: 100 kHz  
ATTEN 30dB    VAVG 100    MKR -24.00dBm  
RL 50.2dBm    10dB/    869.002MHz

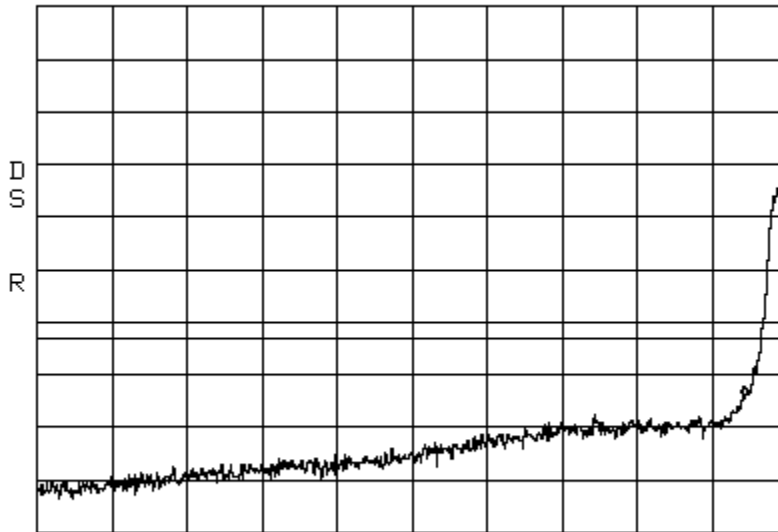

CENTER 866.785MHz                    SPAN 5.000MHz  
\*RBW 30kHz                    \*VBW 100kHz                    SWP 50ms

Band\_Edge                    LTE 3 MHz Channel Bandwidth                    CELL 20W  
Center: 892.5MHz    Span: 5 MHz                    RBW: 30 kHz VBW: 100 kHz  
ATTEN 30dB    VAVG 100    MKR -19.83dBm  
RL 50.2dBm    10dB/    894.000MHz

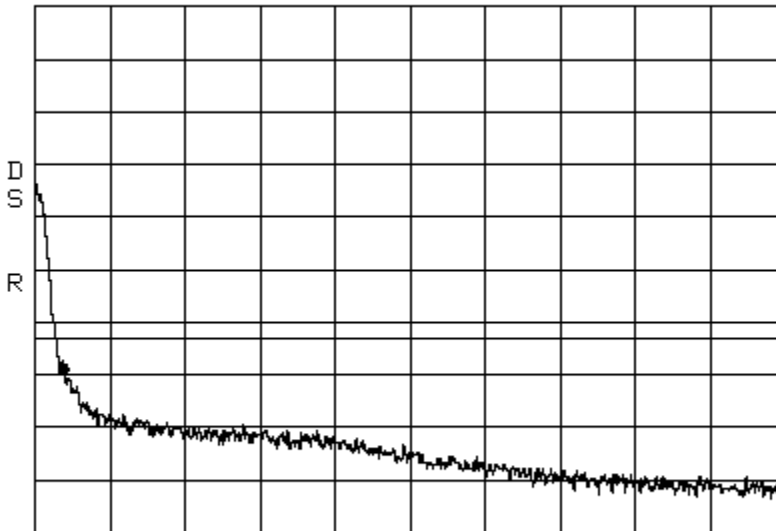

CENTER 896.300MHz                    SPAN 5.000MHz  
\*RBW 30kHz                    \*VBW 100kHz                    SWP 50ms



Band\_Edge                    LTE 5 MHz Channel Bandwidth                    CELL 20W  
 Center: 871.5MHz    Span: 5 MHz                    RBW: 30 kHz VBW: 100 kHz  
 ATTN 30dB    VAVG 100    MKR -27.66dBm  
 RL 50.2dBm    10dB/    869.000MHz

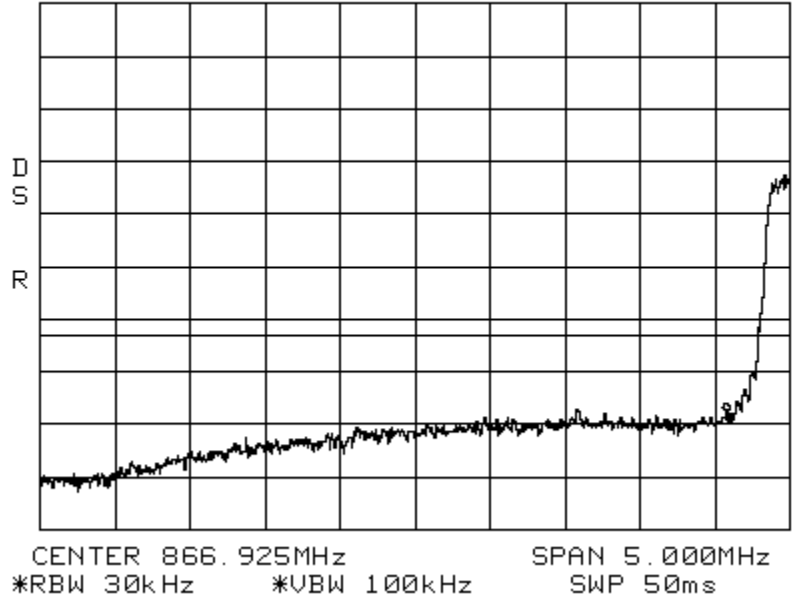

Band\_Edge                    LTE 5 MHz Channel Bandwidth                    CELL 20W  
 Center: 891.5MHz    Span: 5 MHz                    RBW: 30 kHz VBW: 100 kHz  
 ATTN 30dB    VAVG 100    MKR -25.83dBm  
 RL 50.2dBm    10dB/    894.000MHz

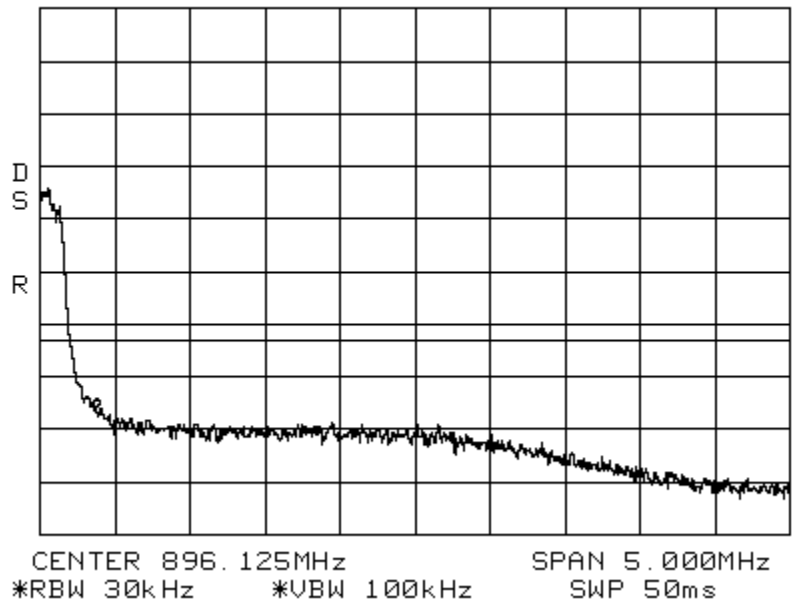

Band\_Edge LTE 10 MHz Channel Bandwidth  
Center: 874.0MHz Span: 15 MHz RBW: 100 kHz  
ATTEN 30dB VAUG 100 MKR -23.83dBm  
RL 50.2dBm 10dB/ 869.00MHz

CELL 20W  
VBW: 100 kHz

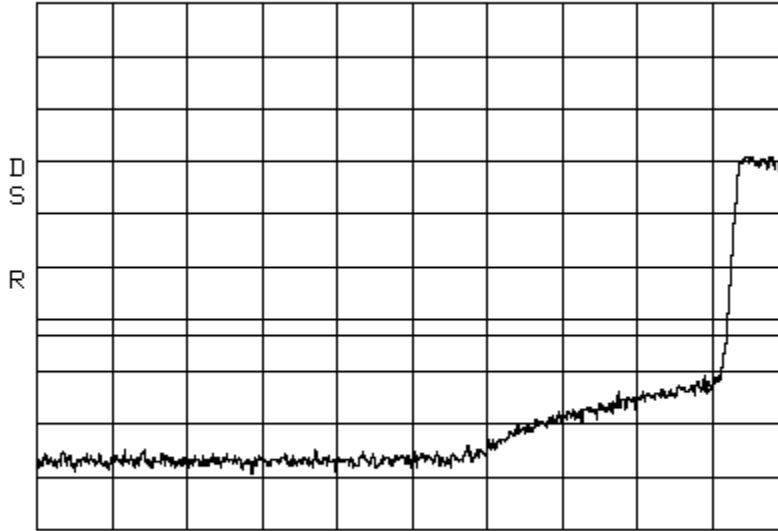

CENTER 863.10MHz SPAN 15.00MHz  
\*RBW 100kHz \*VBW 100kHz SWP 50ms

Band\_Edge LTE 10 MHz Channel Bandwidth  
Center: 889.0MHz Span: 15 MHz RBW: 100 kHz

CELL 20W  
VBW: 100 kHz

ATTEN 30dB VAUG 100 MKR -22.50dBm  
RL 50.2dBm 10dB/ 894.00MHz

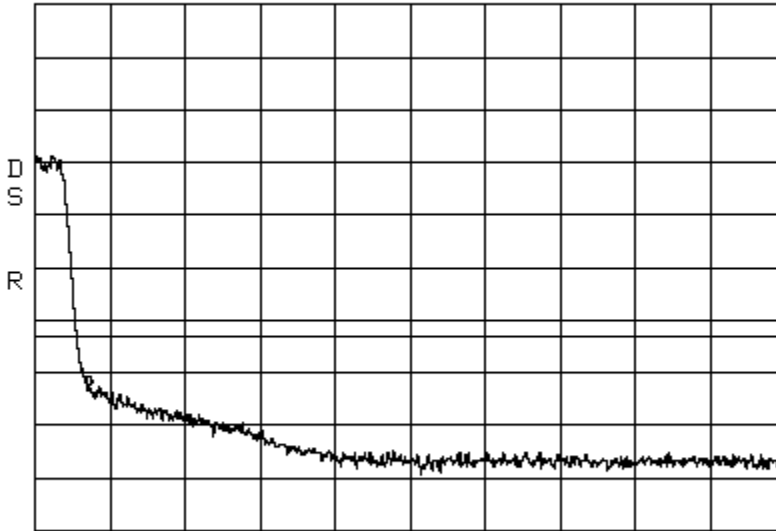

CENTER 900.43MHz SPAN 15.00MHz  
\*RBW 100kHz \*VBW 100kHz SWP 50ms

Band\_Edge WCDMA CELL 20W  
 Center: 867.125MHz Span: 5.5 MHz RBW: 30 kHz VBW: 100 kHz  
 ATTN 30dB VAUG 100 MKR -24.00dBm  
 RL 50.2dBm 10dB/ 869.000MHz

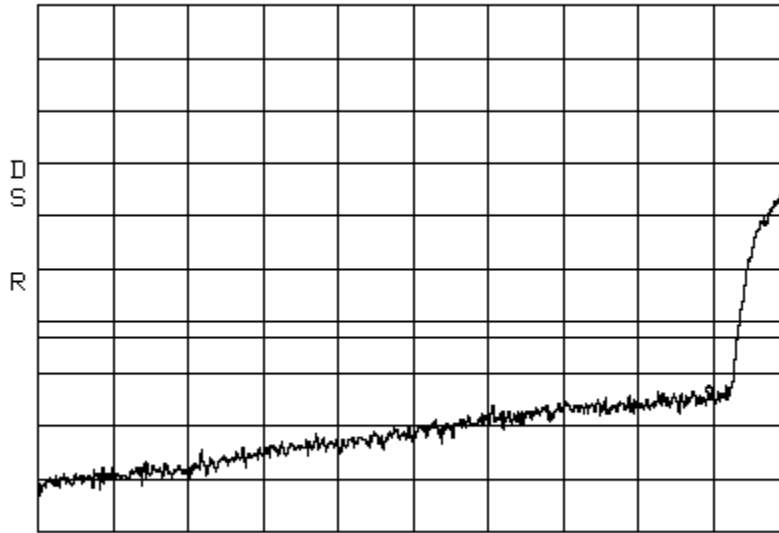

CENTER 867.025MHz SPAN 5.000MHz  
 \*RBW 30kHz \*VBW 100kHz SWP 50ms

Band\_Edge WCDMA CELL 20W  
 Center: 895.825 MHz Span: 5.5 MHz RBW: 30 kHz VBW: 100 kHz  
 ATTN 30dB VAUG 100 MKR -25.00dBm  
 RL 50.2dBm 10dB/ 894.000MHz

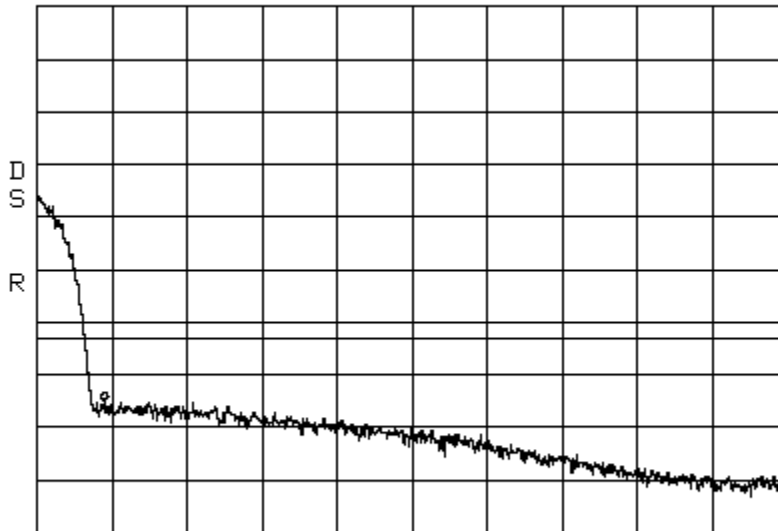

CENTER 896.050MHz SPAN 5.000MHz  
 \*RBW 30kHz \*VBW 100kHz SWP 50ms

Band\_Edge CDMA PCS 20W  
Center: 1930.75 MHz Span: 10 MHz RBW: 10 kHz VBW: 10 kHz

ATTEN 30dB VAUG 100 MKR -27.66dBm  
RL 50.2dBm 10dB/ 1.93000GHz

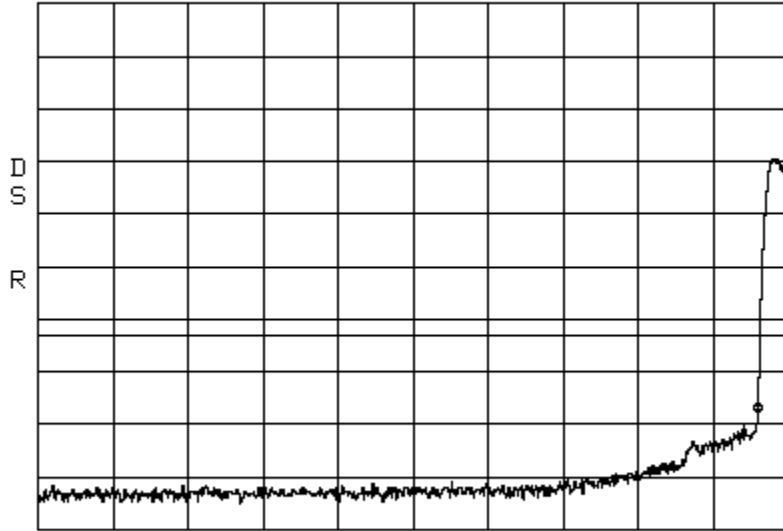

CENTER 1.92540GHz SPAN 10.00MHz  
\*RBW 10kHz \*UBW 10kHz SWP 250ms

Band\_Edge CDMA PCS 20W  
Center: 1994.25 MHz Span: 10 MHz RBW: 10 kHz VBW: 10 kHz

ATTEN 30dB VAUG 100 MKR -34.66dBm  
RL 50.2dBm 10dB/ 1.99500GHz

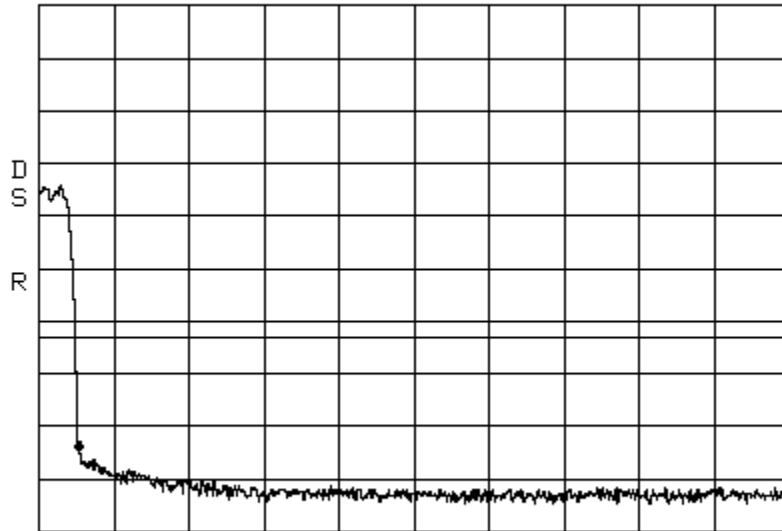

CENTER 1.99947GHz SPAN 10.00MHz  
\*RBW 10kHz \*UBW 10kHz SWP 250ms

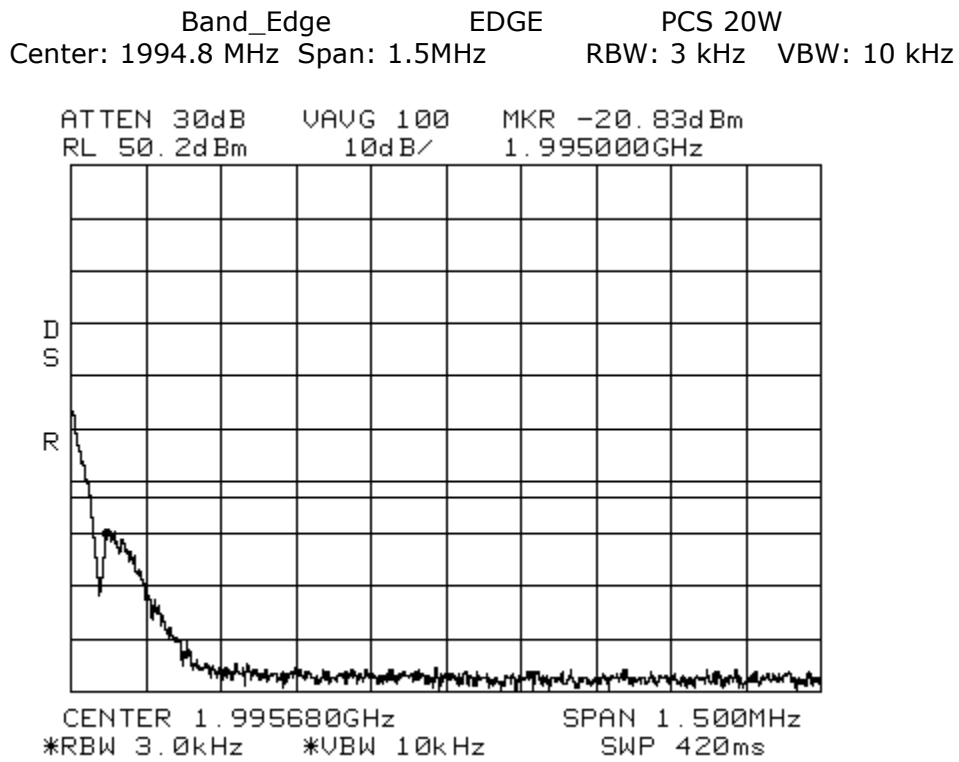
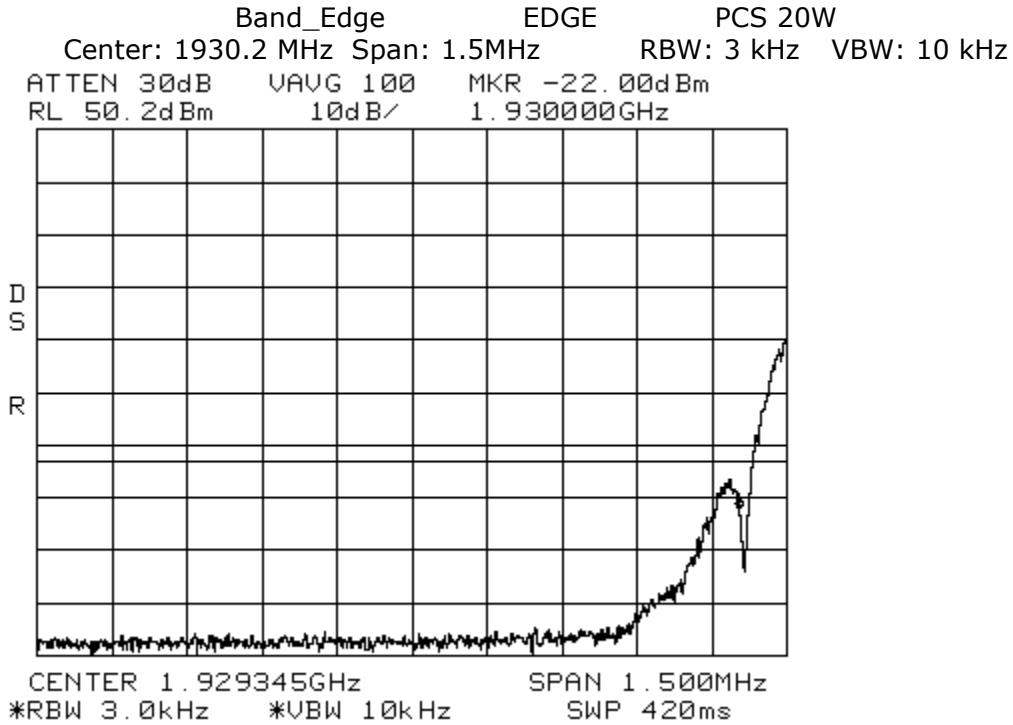

Band\_Edge GSM PCS 20W  
Center: 1930.2 MHz Span: 1.5MHz RBW: 3 kHz VBW: 10 kHz

ATTEN 30dB VAUG 25 MKR -22.33dBm  
RL 50.2dBm 10dB/ 1.930000GHz

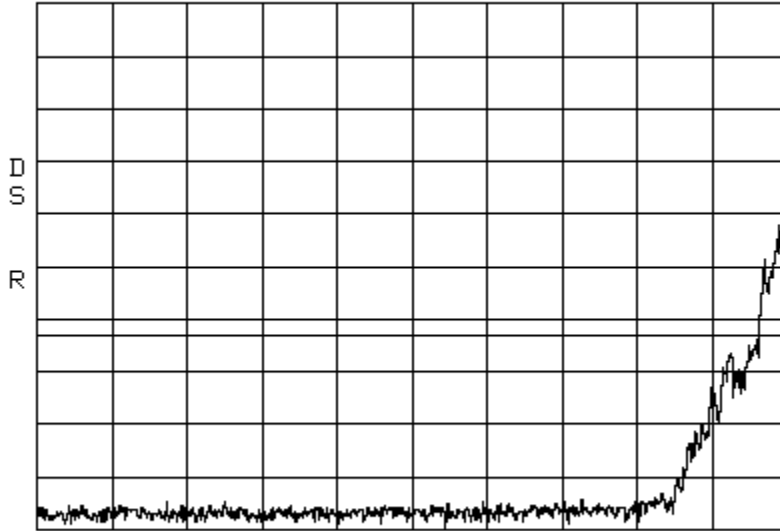

CENTER 1.929345GHz SPAN 1.500MHz  
\*RBW 3.0kHz \*VBW 10kHz SWP 420ms

Band\_Edge GSM PCS 20W  
Center: 1994.8 MHz Span: 1.5MHz RBW: 3 kHz VBW: 10 kHz

ATTEN 30dB VAUG 40 MKR -28.00dBm  
RL 50.2dBm 10dB/ 1.995000GHz

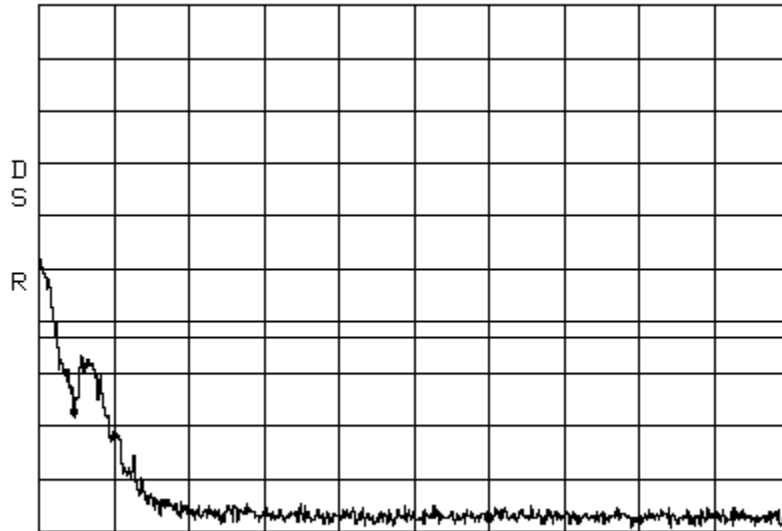

CENTER 1.995680GHz SPAN 1.500MHz  
\*RBW 3.0kHz \*VBW 10kHz SWP 420ms

Band\_Edge                    LTE 3 MHz Channel Bandwidth                    PCS 20W  
Center: 1931.5 MHz Span: 10 MHz                    RBW: 30 kHz VBW: 100 kHz

ATTEN 30dB    VAUG 100    MKR -23.33dBm  
RL 50.2dBm    10dB/    1.93000GHz

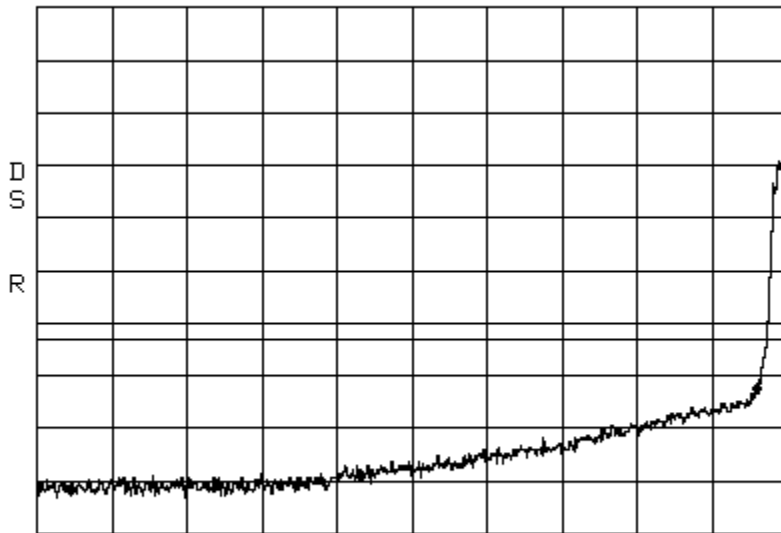

CENTER 1.92540GHz                    SPAN 10.00MHz  
\*RBW 30kHz    \*VBW 100kHz    SWP 50ms

Band\_Edge                    LTE 3MHz Channel Bandwidth                    PCS 20W  
Center: 1993.5MHz Span: 10 MHz                    RBW: 30 kHz VBW: 100 kHz

ATTEN 30dB    VAUG 100    MKR -19.50dBm  
RL 50.2dBm    10dB/    1.99501GHz

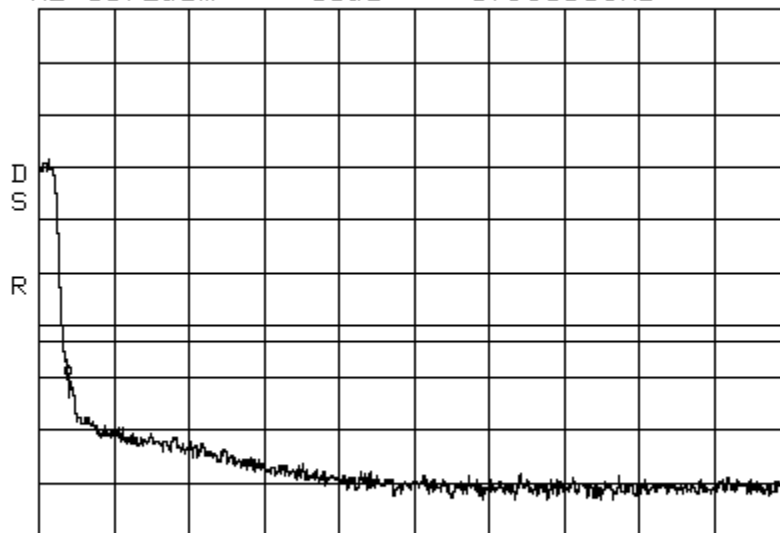

CENTER 1.99963GHz                    SPAN 10.00MHz  
\*RBW 30kHz    \*VBW 100kHz    SWP 50ms

Band\_Edge                    LTE 5 MHz Channel Bandwidth                    PCS 20W  
 Center: 1932.5MHz    Span: 10 MHz                    RBW: 30 kHz    VBW: 100 kHz  
 ATTN 30dB    VAUG 100    MKR -31.16dBm  
 RL 50.2dBm    10dB/    1.93000GHz

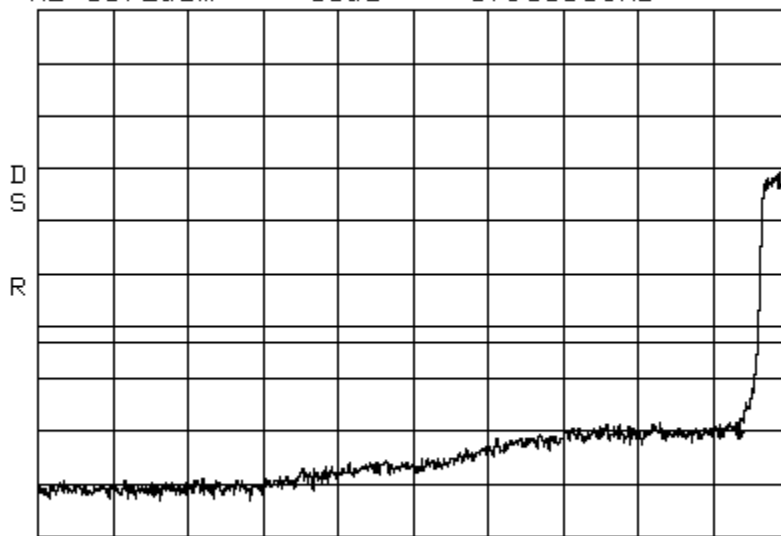

CENTER 1.92565GHz                    SPAN 10.00MHz  
 \*RBW 30kHz                    \*VBW 100kHz                    SWP 50ms

Band\_Edge                    LTE 5 MHz Channel Bandwidth                    PCS 20W  
 Center: 1992.5MHz    Span: 10 MHz                    RBW: 30 kHz    VBW: 100 kHz

ATTN 30dB    VAUG 100    MKR -26.50dBm  
 RL 50.2dBm    10dB/    1.99501GHz

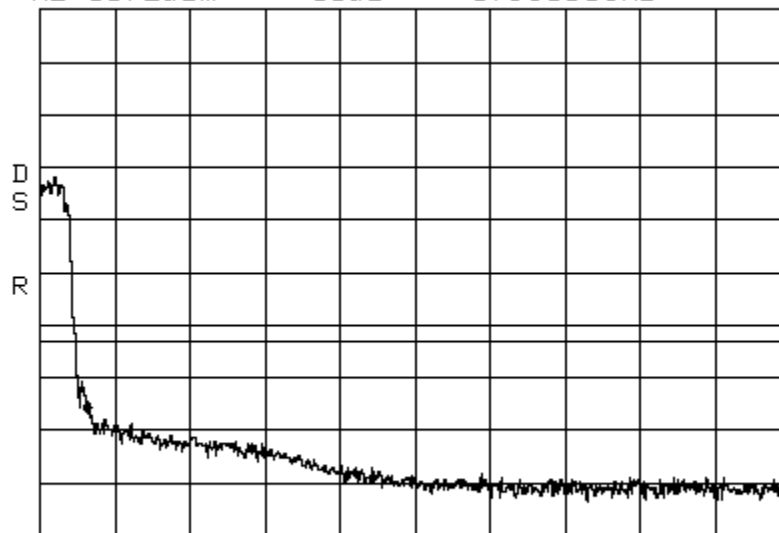

CENTER 1.99938GHz                    SPAN 10.00MHz  
 \*RBW 30kHz                    \*VBW 100kHz                    SWP 50ms



Band\_Edge                      LTE 10 MHz Channel Bandwidth                      PCS 20W  
 Center: 1935.0MHz                      Span: 15 MHz                      RBW: 100 kHz                      VBW: 100 kHz  
 ATTN 30dB                      VAUG 100                      MKR -22.33dBm  
 RL 50.2dBm                      10dB/                      1.93000GHz

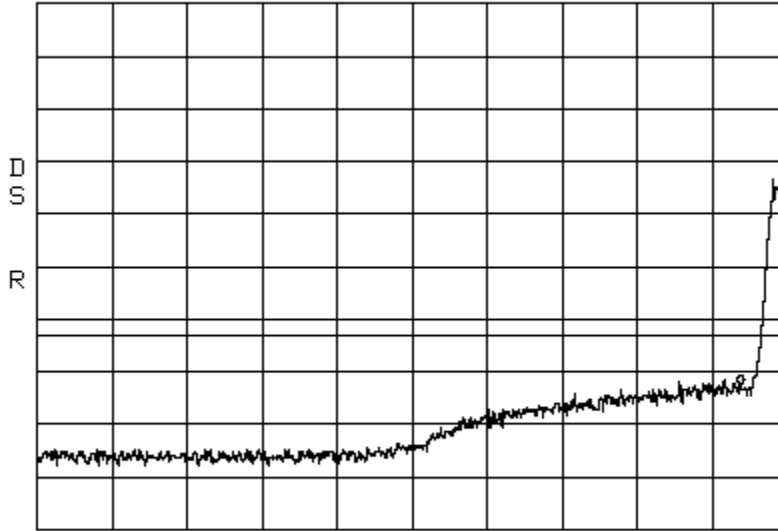

CENTER 1.92342GHz                      SPAN 15.00MHz  
 \*RBW 100kHz                      \*VBW 100kHz                      SWP 50ms

Band\_Edge                      LTE 10 MHz Channel Bandwidth                      PCS 20W  
 Center: 1990.0MHz                      Span: 15 MHz                      RBW: 100 kHz                      VBW: 100 kHz

ATTN 30dB                      VAUG 100                      MKR -25.00dBm  
 RL 50.2dBm                      10dB/                      1.99500GHz

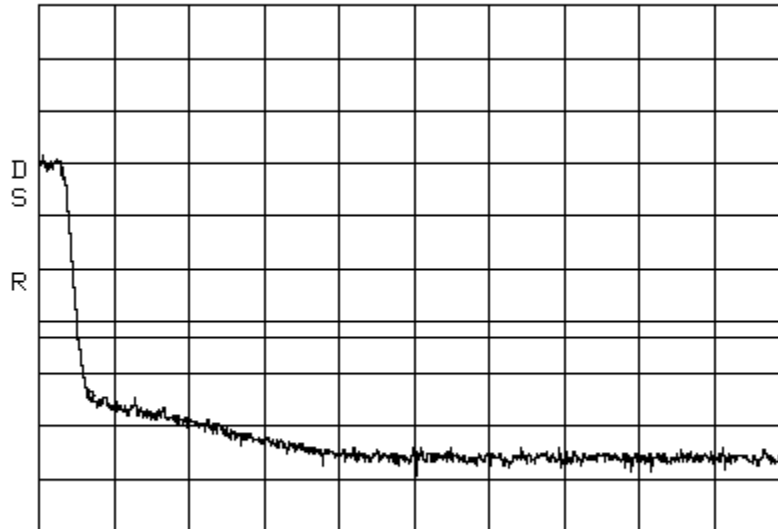

CENTER 2.00148GHz                      SPAN 15.00MHz  
 \*RBW 100kHz                      \*VBW 100kHz                      SWP 50ms

Band\_Edge                    LTE 15 MHz Channel Bandwidth                    PCS 20W  
 Center: 1937.5MHz    Span: 15 MHz                    RBW: 100 kHz                    VBW: 100 kHz  
 ATTN 30dB    VAUG 100    MKR -24.83dBm  
 RL 50.2dBm    10dB/    1.93000GHz

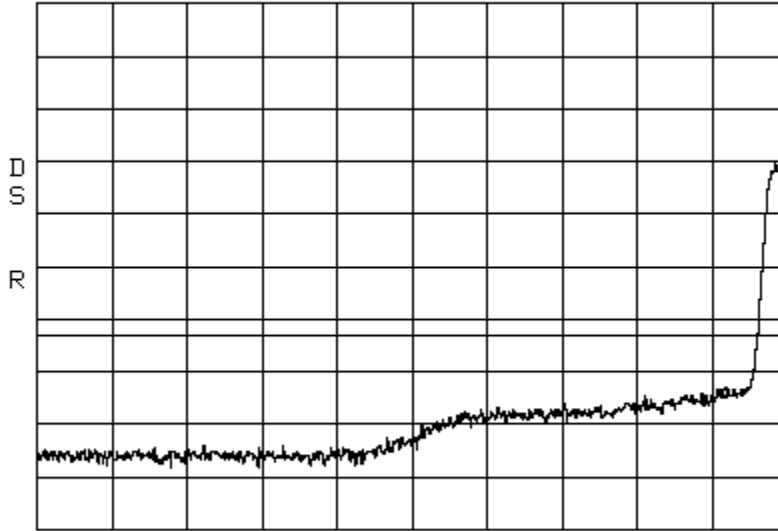

CENTER 1.92372GHz                    SPAN 15.00MHz  
 \*RBW 100kHz    \*VBW 100kHz                    SWP 50ms

Band\_Edge                    LTE 15 MHz Channel Bandwidth                    PCS 20W  
 Center: 1987.5MHz    Span: 15 MHz                    RBW: 100kHz VBW: 100 kHz

ATTN 30dB    VAUG 100    MKR -24.33dBm  
 RL 50.2dBm    10dB/    1.99500GHz

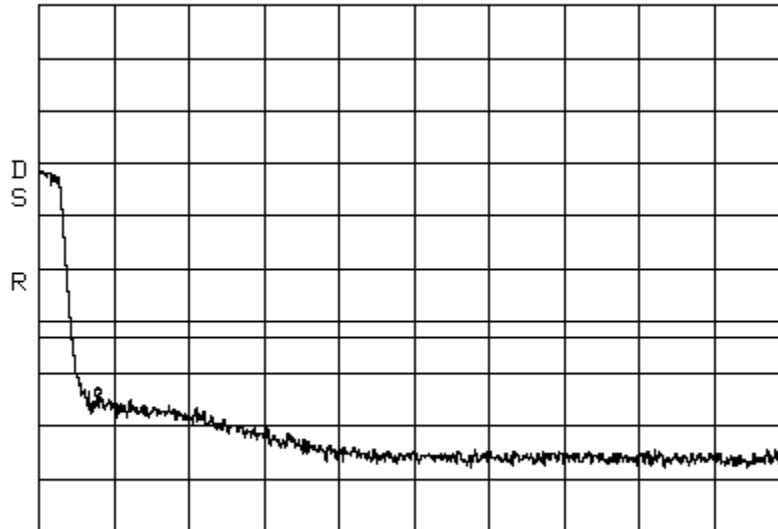

CENTER 2.00133GHz                    SPAN 15.00MHz  
 \*RBW 100kHz    \*VBW 100kHz                    SWP 50ms

Band\_Edge WCDMA PCS 20W  
Center: 1932.5 MHz Span: 10 MHz RBW: 30 kHz VBW: 100 kHz

ATTEN 30dB VAUG 100 MKR -26.33dBm  
RL 50.2dBm 10dB/ 1.93000GHz

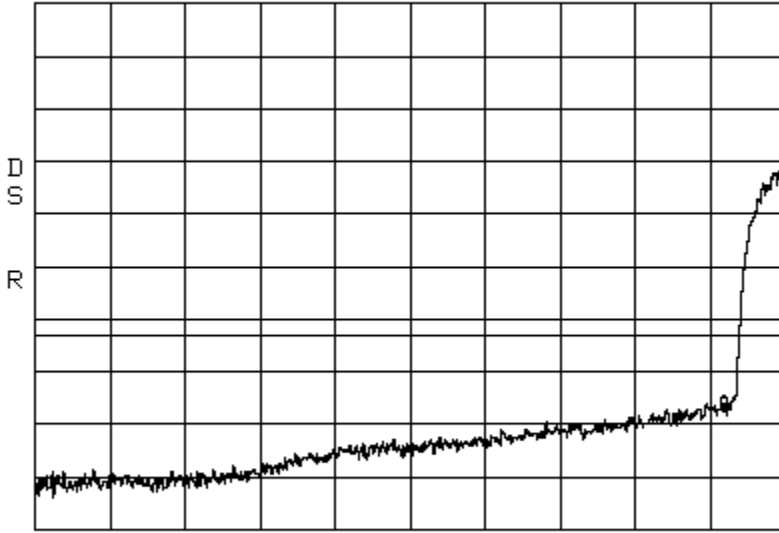

CENTER 1.92582GHz SPAN 10.00MHz  
\*RBW 30kHz \*VBW 100kHz SWP 50ms

Band\_Edge WCDMA PCS 20W  
Center: 1992.5 MHz Span: 10 MHz RBW: 30 kHz VBW: 100 kHz

ATTEN 30dB VAUG 100 MKR -30.66dBm  
RL 50.2dBm 10dB/ 1.99500GHz

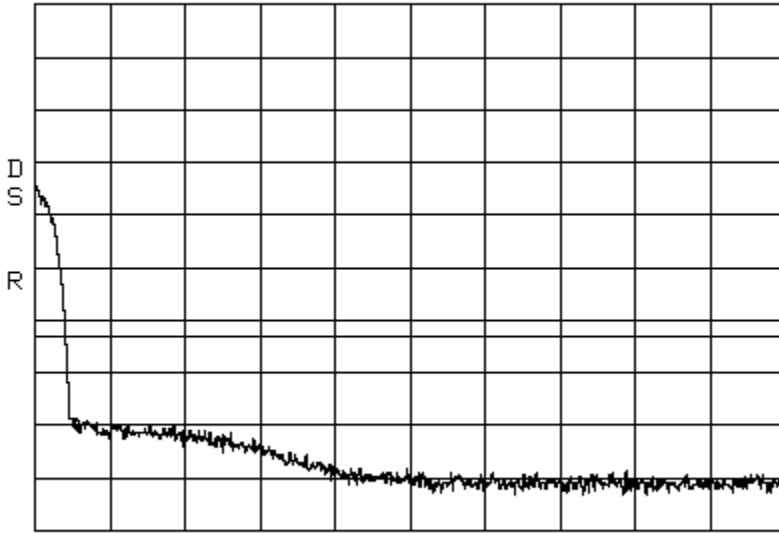

CENTER 1.99945GHz SPAN 10.00MHz  
\*RBW 30kHz \*VBW 100kHz SWP 50ms

## 6.2 FCC 2.1049, 22.917, & 24.238 – Occupied Bandwidth

### Test Summary:

- The requirements are:                   • **MET**                   ◦ NOT MET

### Test Methods Used:

TIA-603-C 2004, ANSI C63.4-2003, FCC 2.0149, 22.917, & 24.238

### Test Procedure:

The RF Output of the transmitter was connected to input of the spectrum analyzer through sufficient attenuation.

An input/output Occupied Bandwidth test was done with modulation types: GSM, EDGE, CDMA, WCDMA, LTE 3 MHz, LTE 5MHz, LTE 10MHz, & LTE 15MHz Channel Bandwidths. The purpose was to determine the amount of distortion added to different types of modulation schemes by the EUT.

The resolution bandwidth is reduced to 1% of the estimated emission bandwidth and the video bandwidth is set to 3 times the resolution bandwidth. The markers are moved to the -20 dB points (from the previously established center frequency level) on either side of center frequency.

**Test Date: 10/30/12**

**Tests Conducted By: Joshua J. Wittman**

**Test Equipment: 1, 2, 6, 9, 12**

Number	Description	Manufacturer	Model	ADC TELECOMMUNICATIONS Serial Number	Cal Due	Used
1	Spectrum Analyzer	HP	8563E	MC27690	6-30-13	<input checked="" type="checkbox"/>
2	Power Meter	HP	437B	MC27754	6-30-13	<input checked="" type="checkbox"/>
6	Signal Generator	Aeroflex	3413	MC57343	2-9-13	<input checked="" type="checkbox"/>
9	Digital Barometer	Fisher Scientific	02-403	MC50719	1-25-13	<input checked="" type="checkbox"/>
12	RF Power Sensor	Agilent	8482A	MC48747	6-30-13	<input checked="" type="checkbox"/>

### Environmental Conditions in the lab:

**Temperature:** 28° C

**Relative Humidity:** 20%

**Atmospheric Pressure:** 99.0 kPa

**Test Results:**

Occupied Bandwidth  
Span: 1.5 MHz

CDMA\_Signal\_In CELL 20W  
RBW: 30 kHz VBW: 100 kHz

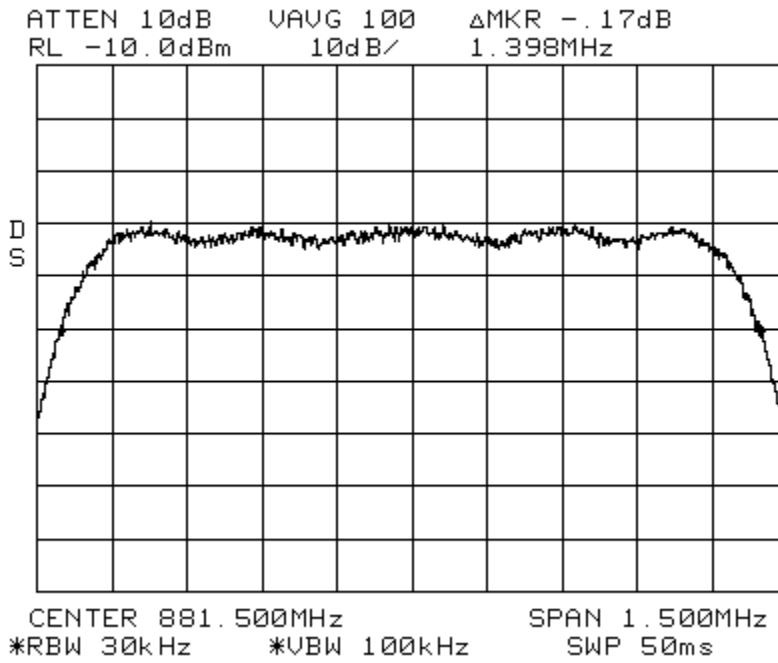

Occupied Bandwidth  
Span: 1.5 MHz

CDMA\_Signal\_Out CELL 20W  
RBW: 30 kHz VBW: 100 kHz

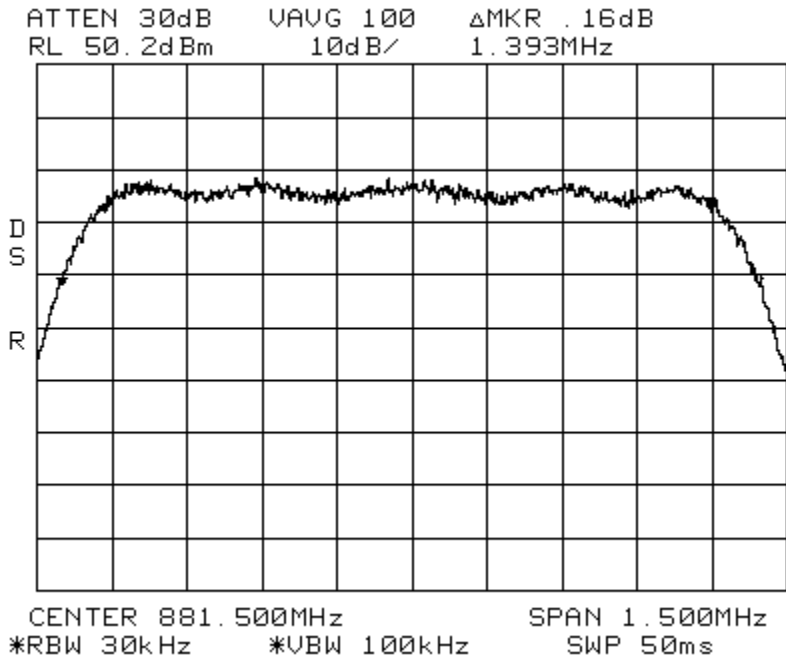

Occupied Bandwidth  
Span: 350 kHz

EDGE\_Signal\_In

RBW: 3 kHz VBW: 10 kHz

CELL 20W

ATTEN 10dB VAUG 100 ΔMKR .16dB  
RL -10.0dBm 10dB/ 268.3kHz

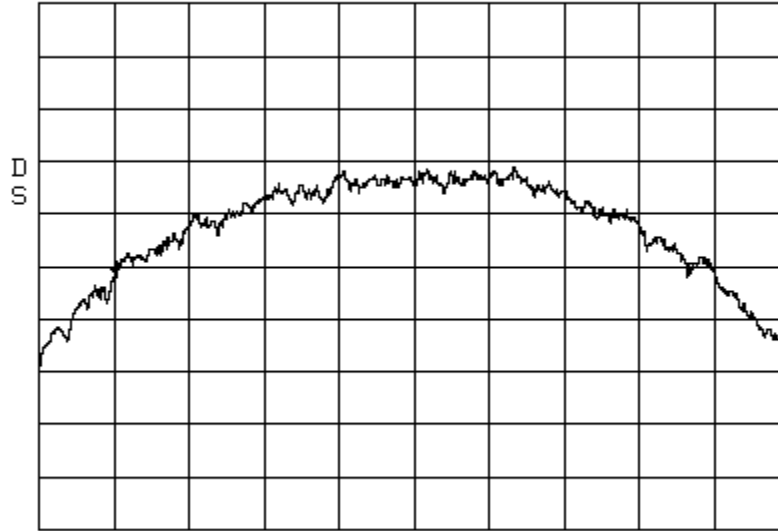

CENTER 881.5000MHz SPAN 350.0kHz  
\*RBW 3.0kHz \*VBW 10kHz SWP 98ms

Occupied Bandwidth  
Span: 350 kHz

EDGE\_Signal\_Out

RBW: 3 kHz VBW: 10 kHz

CELL 20W

ATTEN 30dB VAUG 100 ΔMKR -.50dB  
RL 50.2dBm 10dB/ 266.6kHz

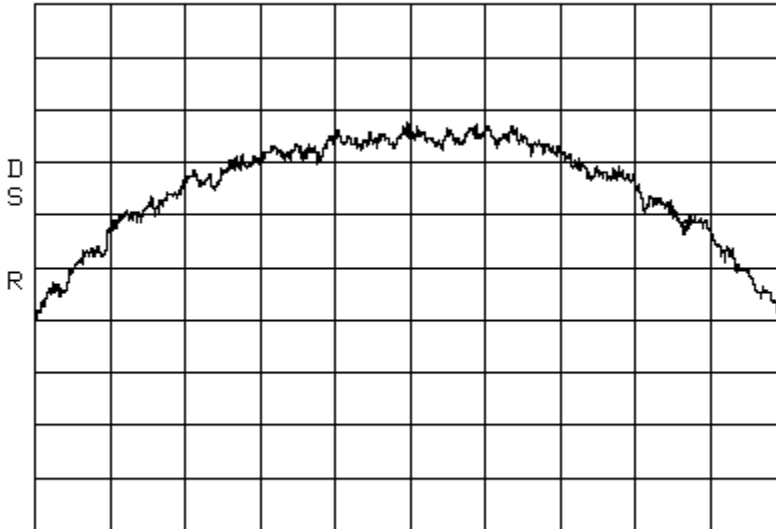

CENTER 881.5000MHz SPAN 350.0kHz  
\*RBW 3.0kHz \*VBW 10kHz SWP 98ms

Occupied Bandwidth  
Span: 350 kHz

GSM\_Signal\_In CELL 20W  
RBW: 3 kHz VBW: 10 kHz

ATTEN 10dB VAUG 100 ΔMKR -.17dB  
RL -10.0dBm 10dB/ 256.7kHz

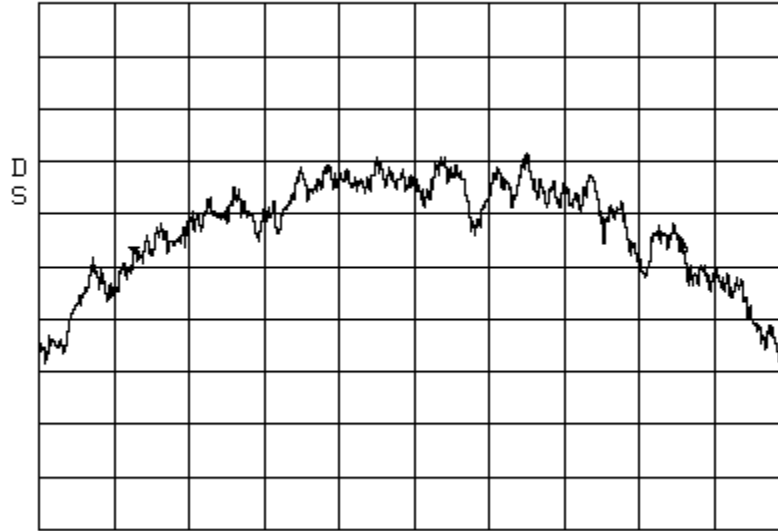

CENTER 881.5000MHz SPAN 350.0kHz  
\*RBW 3.0kHz \*VBW 10kHz SWP 98ms

Occupied Bandwidth  
Span: 350 kHz

GSM\_Signal\_Out CELL 20W  
RBW: 3 kHz VBW: 10 kHz

ATTEN 30dB VAUG 100 ΔMKR -1.00dB  
RL 50.2dBm 10dB/ 258.4kHz

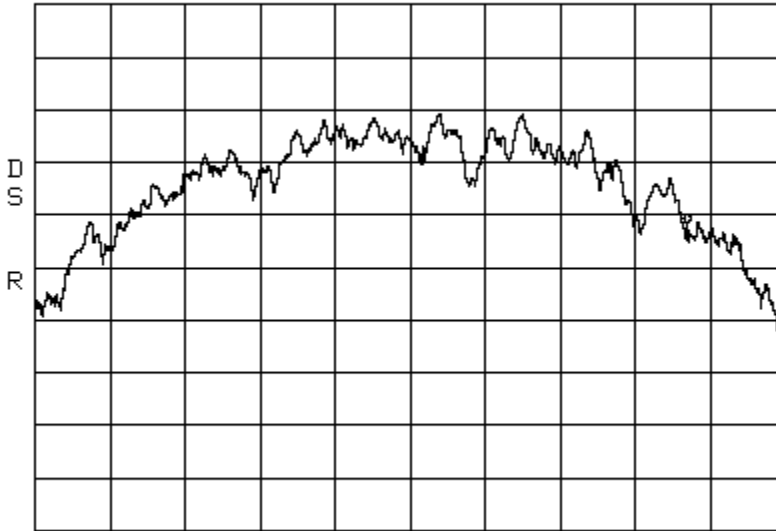

CENTER 881.5000MHz SPAN 350.0kHz  
\*RBW 3.0kHz \*VBW 10kHz SWP 98ms

Occupied Bandwidth

LTE 3 MHz Channel Bandwidth\_Signal\_In

CELL 20W

Span: 3 MHz

RBW: 30kHz VBW: 100 kHz

ATTEN 10dB

VAUG 100

$\Delta$ MKR -.67dB

RL -10.0dBm

10dB/

2.830MHz

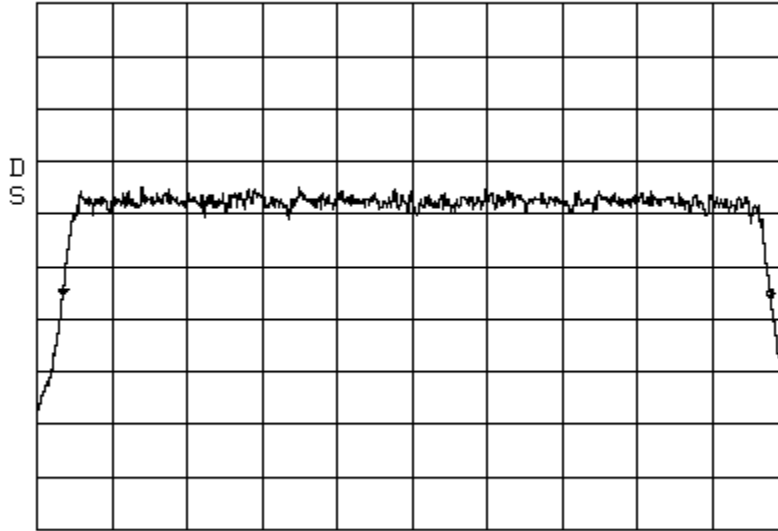

CENTER 881.500MHz SPAN 3.000MHz  
\*RBW 30kHz \*VBW 100kHz SWP 50ms

Occupied Bandwidth

LTE 3 MHz Channel Bandwidth\_Signal\_Out

CELL 20W

Span: 3 MHz

RBW: 30 kHz VBW: 100 kHz

ATTEN 30dB

VAUG 100

$\Delta$ MKR .33dB

RL 50.2dBm

10dB/

2.835MHz

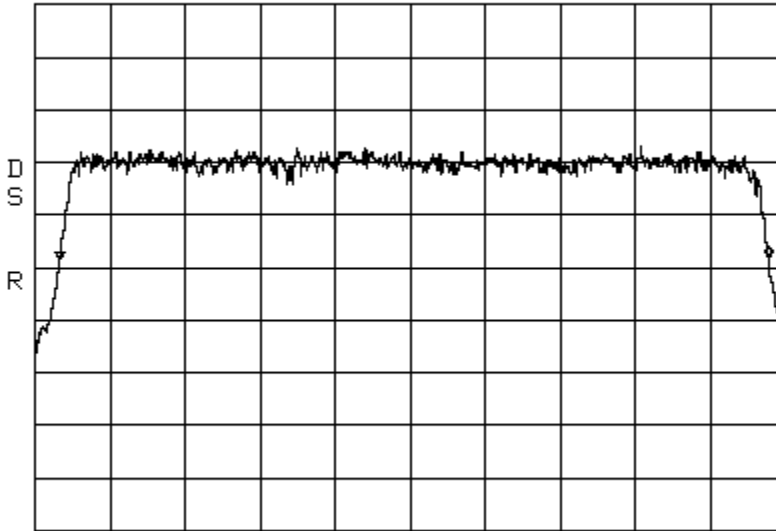

CENTER 881.500MHz SPAN 3.000MHz  
\*RBW 30kHz \*VBW 100kHz SWP 50ms



Occupied Bandwidth LTE 5 MHz Channel Bandwidth\_Signal\_In  
Span: 5 MHz RBW: 30 kHz VBW: 100 kHz

CELL 20W

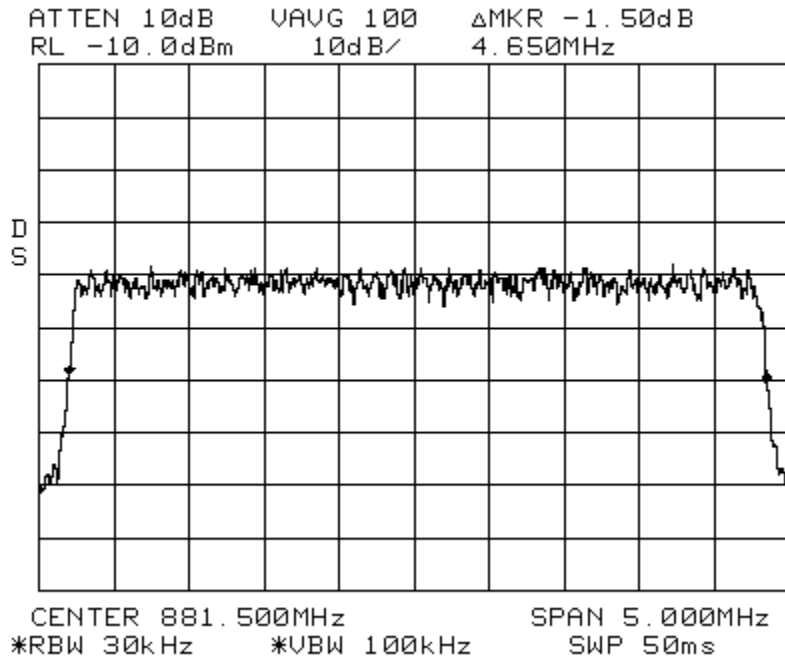

Occupied Bandwidth LTE 5 MHz Channel Bandwidth\_Signal\_Out  
Span: 5 MHz RBW: 30 kHz VBW: 100 kHz

CELL 20W

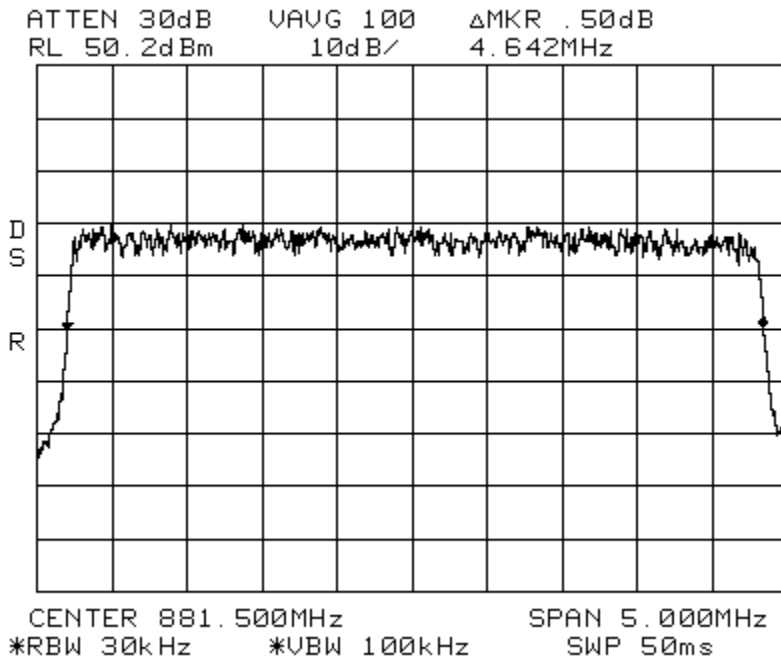

Occupied Bandwidth

LTE 10 MHz Channel Bandwidth\_Signal\_In  
Span: 10 MHz

CELL 20W

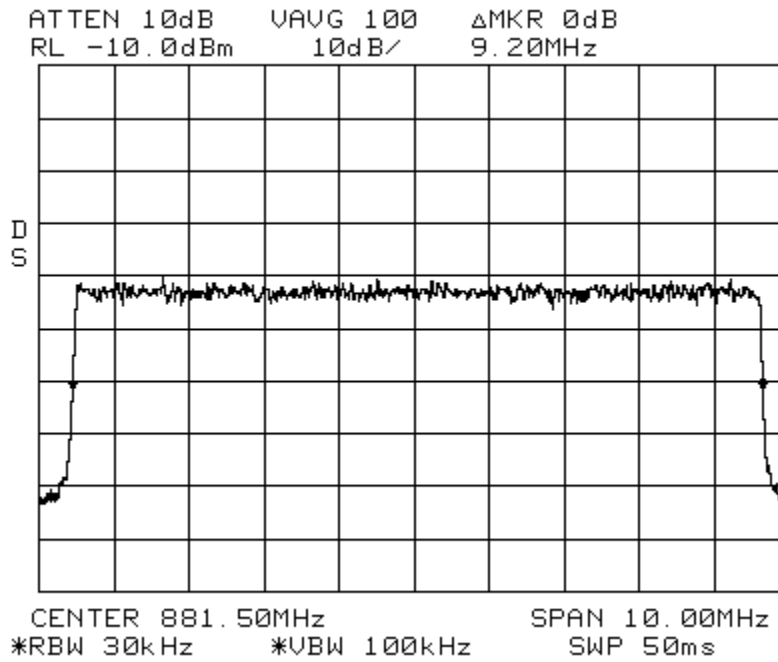

Occupied Bandwidth

LTE 10 MHz Channel Bandwidth\_Signal\_Out  
Span: 10 MHz

CELL 20W

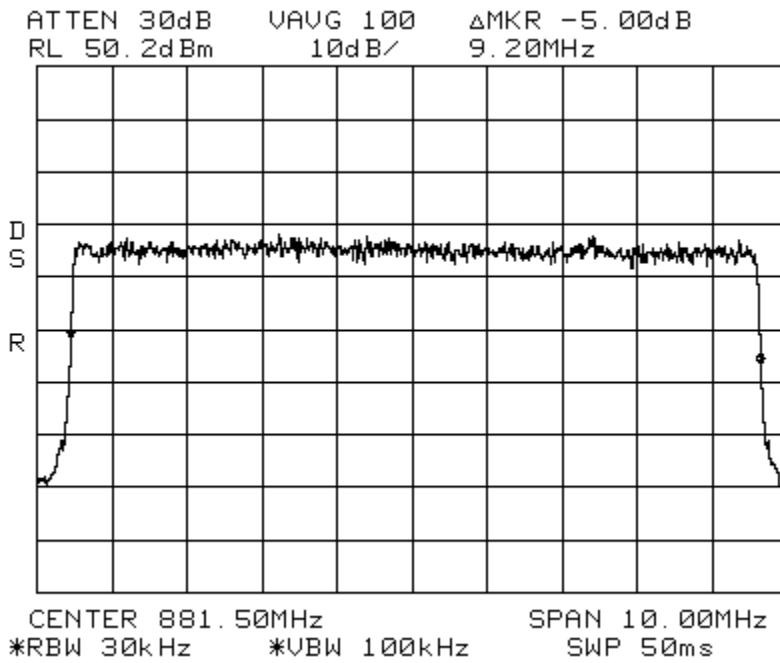

Occupied Bandwidth  
Span: 5.0 MHz

WCDMA\_Signal\_In  
RBW: 30 kHz VBW: 100 kHz

CELL 20W

ATTEN 10dB VAUG 100 ΔMKR -.33dB  
RL -10.0dBm 10dB/ 4.592MHz

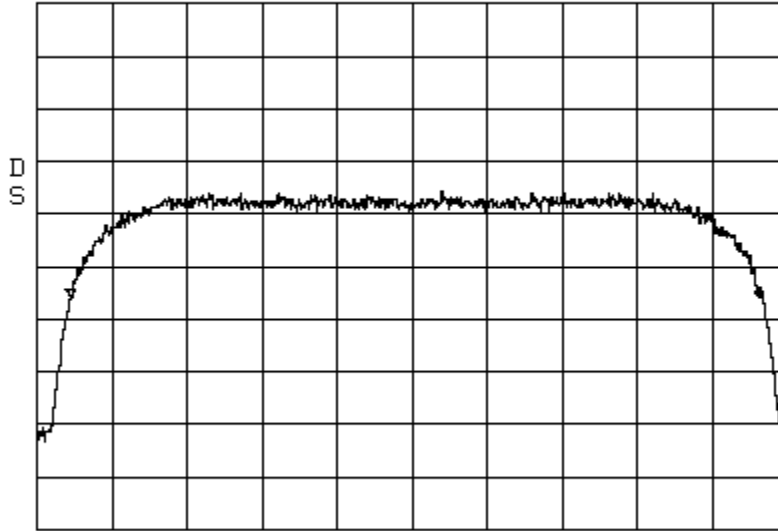

CENTER 881.500MHz SPAN 5.000MHz  
\*RBW 30kHz \*VBW 100kHz SWP 50ms

Occupied Bandwidth  
Span: 5.0 MHz

WCDMA\_Signal\_Out  
RBW: 30 kHz VBW: 100 kHz

CELL 20W

ATTEN 30dB VAUG 100 ΔMKR -.50dB  
RL 50.2dBm 10dB/ 4.617MHz

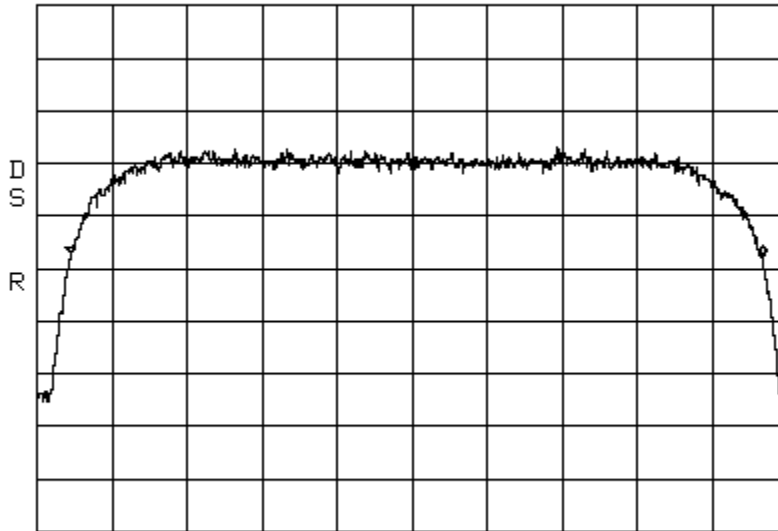

CENTER 881.500MHz SPAN 5.000MHz  
\*RBW 30kHz \*VBW 100kHz SWP 50ms

Occupied Bandwidth      CDMA\_Signal\_In      PCS 20W  
 Span: 1.5 MHz      RBW: 30 kHz VBW: 100 kHz  
 ATTN 10dB      VAUG 100      ΔMKR .17dB  
 RL -10.0dBm      10dB/      1.400MHz

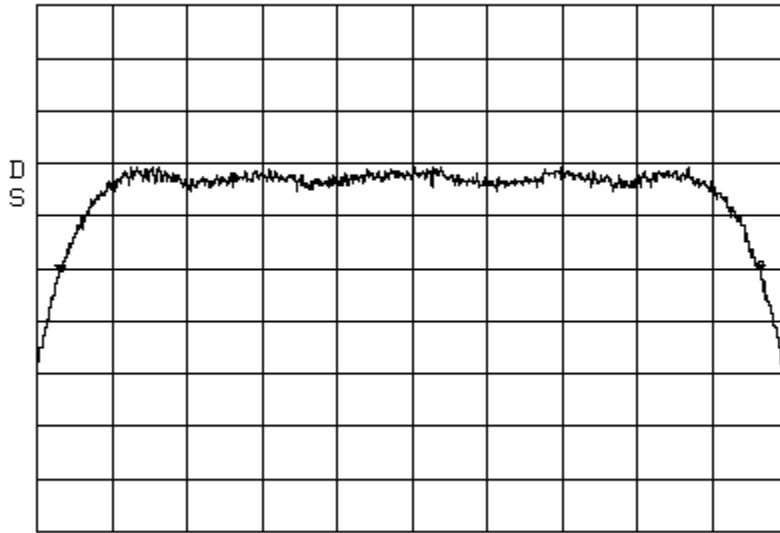

CENTER 1.962500GHz      SPAN 1.500MHz  
 \*RBW 30kHz      \*VBW 100kHz      SWP 50ms

Occupied Bandwidth      CDMA\_Signal\_Out      PCS 20W  
 Span: 1.5 MHz      RBW: 30 kHz VBW: 100 kHz  
 ATTN 30dB      VAUG 100      ΔMKR 0dB  
 RL 50.2dBm      10dB/      1.400MHz

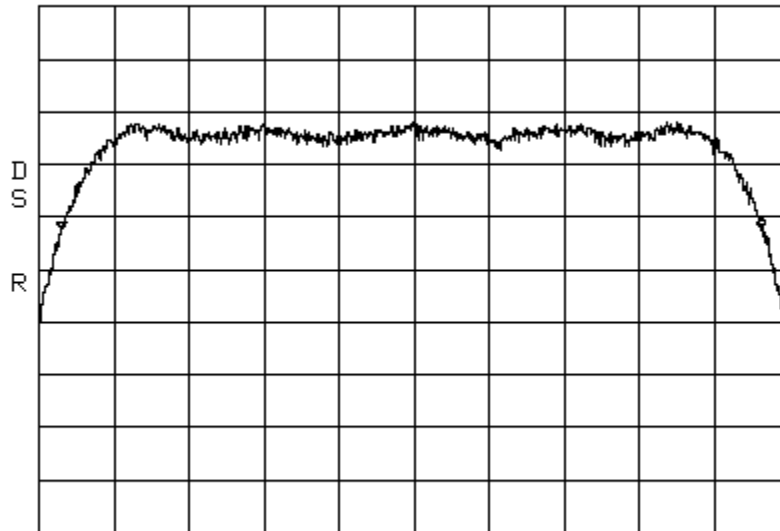

CENTER 1.962500GHz      SPAN 1.500MHz  
 \*RBW 30kHz      \*VBW 100kHz      SWP 50ms

Occupied Bandwidth  
Span: 350 kHz

EDGE\_Signal\_In PCS 20W  
RBW: 3 kHz VBW: 10 kHz

ATTEN 10dB VAUG 100 ΔMKR .16dB  
RL -10.0dBm 10dB/ 278.8kHz

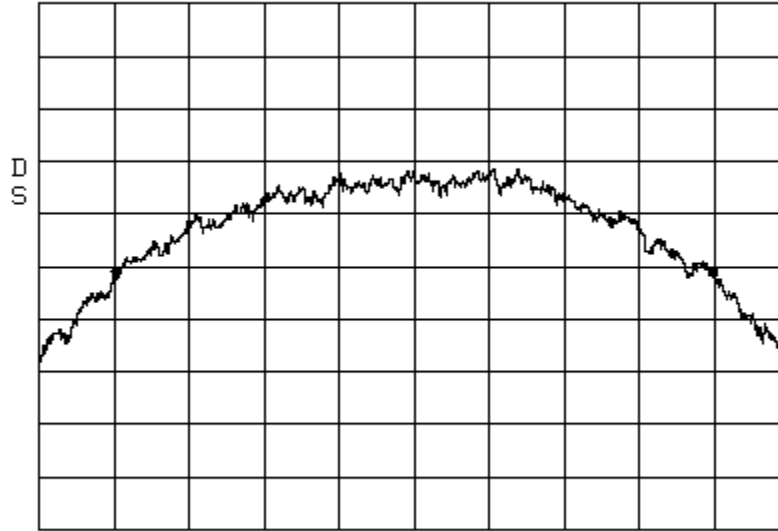

CENTER 1.9625000GHz SPAN 350.0kHz  
\*RBW 3.0kHz \*VBW 10kHz SWP 98ms

Occupied Bandwidth  
Span: 350 kHz

EDGE\_Signal\_Out PCS 20W  
RBW: 3 kHz VBW: 10 kHz

ATTEN 30dB VAUG 100 ΔMKR 0dB  
RL 50.2dBm 10dB/ 280.0kHz

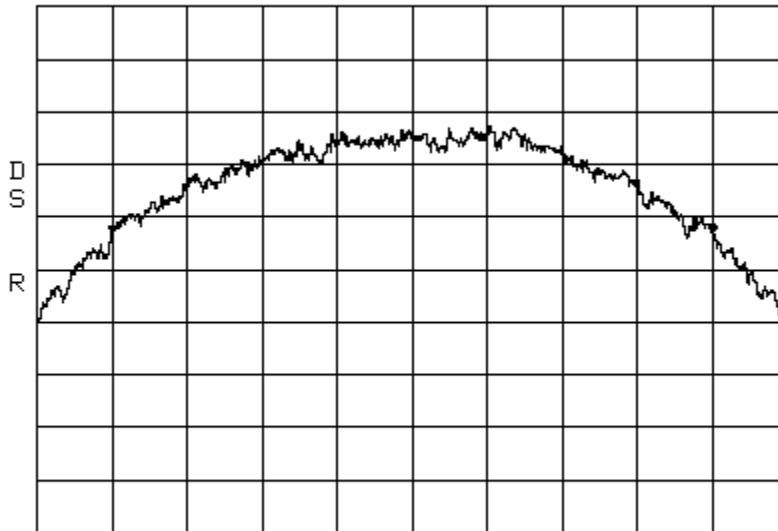

CENTER 1.9625000GHz SPAN 350.0kHz  
\*RBW 3.0kHz \*VBW 10kHz SWP 98ms

Occupied Bandwidth  
Span: 350 kHz

GSM\_Signal\_In PCS 20W  
RBW: 3 kHz VBW: 10 kHz

ATTEN 10dB VAUG 100 ΔMKR -.33dB  
RL -10.0dBm 10dB/ 260.8kHz

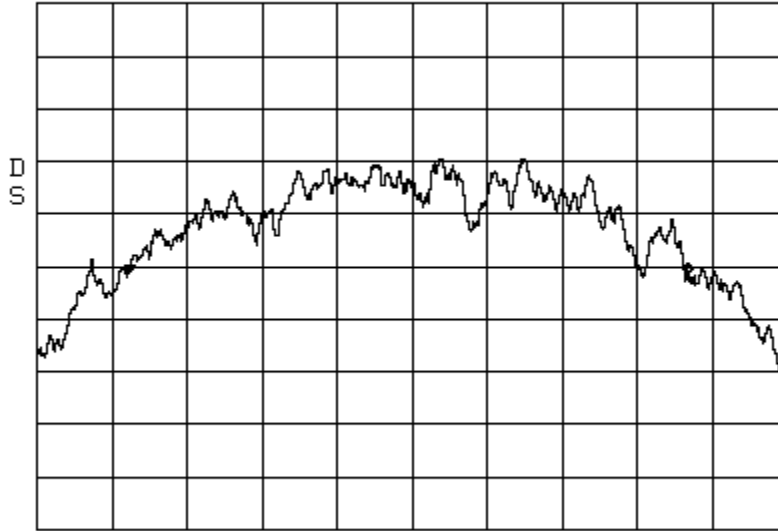

CENTER 1.962500GHz SPAN 350.0kHz  
\*RBW 3.0kHz \*VBW 10kHz SWP 98ms

Occupied Bandwidth  
Span: 350 kHz

GSM\_Signal\_Out PCS 20W  
RBW: 3 kHz VBW: 10 kHz

ATTEN 30dB VAUG 100 ΔMKR -.67dB  
RL 50.2dBm 10dB/ 267.2kHz

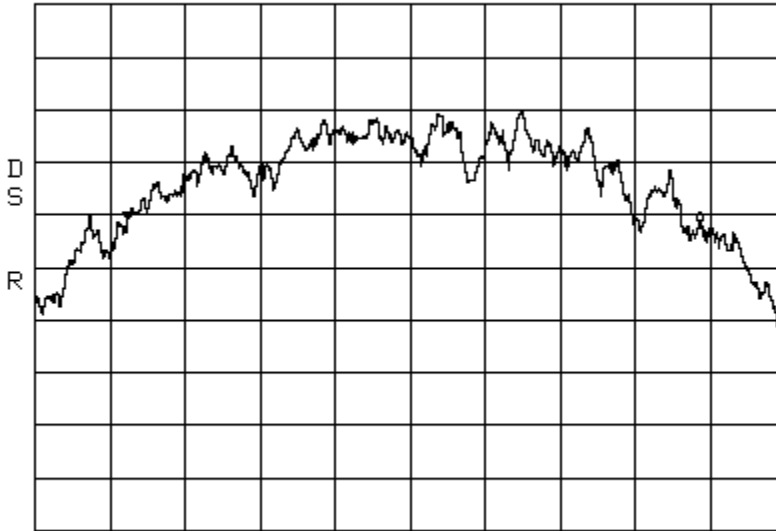

CENTER 1.962500GHz SPAN 350.0kHz  
\*RBW 3.0kHz \*VBW 10kHz SWP 98ms

Occupied Bandwidth

LTE 3 MHz Channel Bandwidth\_Signal\_In

PCS 20W

Span: 3 MHz

RBW: 30kHz VBW: 100 kHz

ATTEN 10dB

$\Delta$ MKR .17dB

RL -20.0dBm

10dB/

2.850MHz

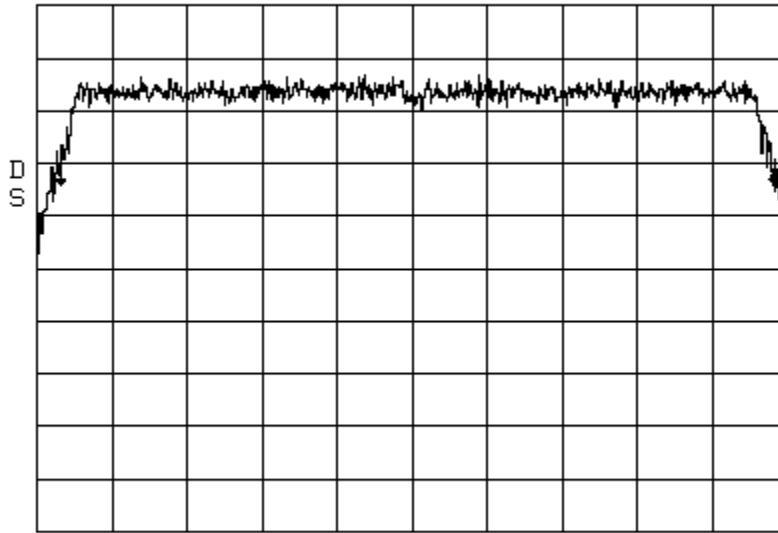

CENTER 1.96250GHz SPAN 3.000MHz  
\*RBW 30kHz \*VBW 100kHz SWP 50ms

Occupied Bandwidth

LTE 3 MHz Channel Bandwidth\_Signal\_Out

PCS 20W

Span: 3 MHz

RBW: 30 kHz VBW: 100 kHz

ATTEN 30dB

UAUG 100

$\Delta$ MKR .83dB

RL 50.2dBm

10dB/

2.820MHz

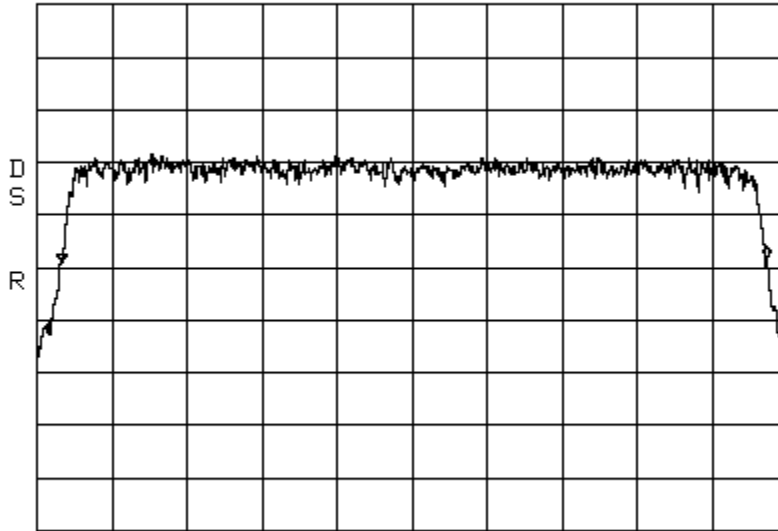

CENTER 1.96250GHz SPAN 3.000MHz  
\*RBW 30kHz \*VBW 100kHz SWP 50ms

Occupied Bandwidth

LTE 5 MHz Channel Bandwidth\_Signal\_In

PCS 20W

Span: 5 MHz

RBW: 30 kHz VBW: 100 kHz

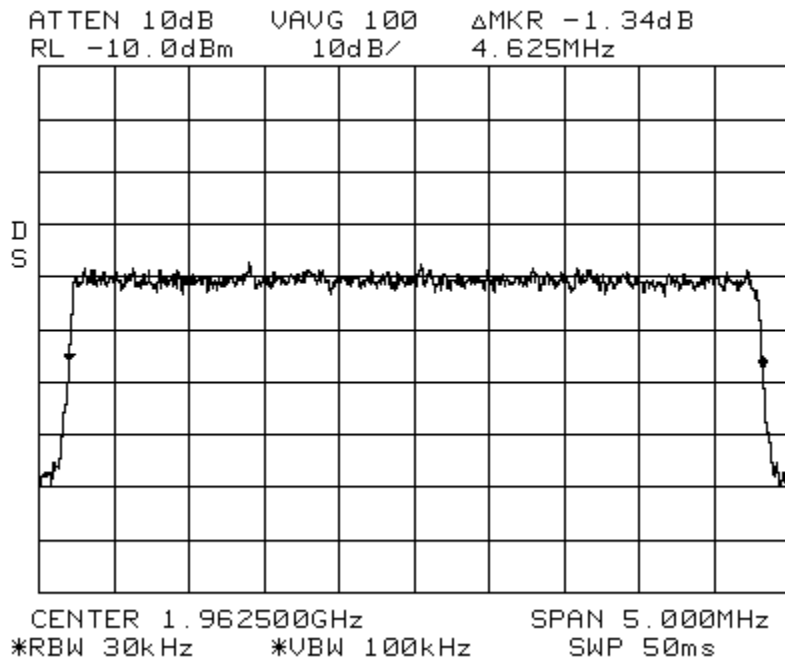

Occupied Bandwidth

LTE 5 MHz Channel Bandwidth\_Signal\_Out

PCS 20W

Span: 5 MHz

RBW: 30 kHz VBW: 100 kHz

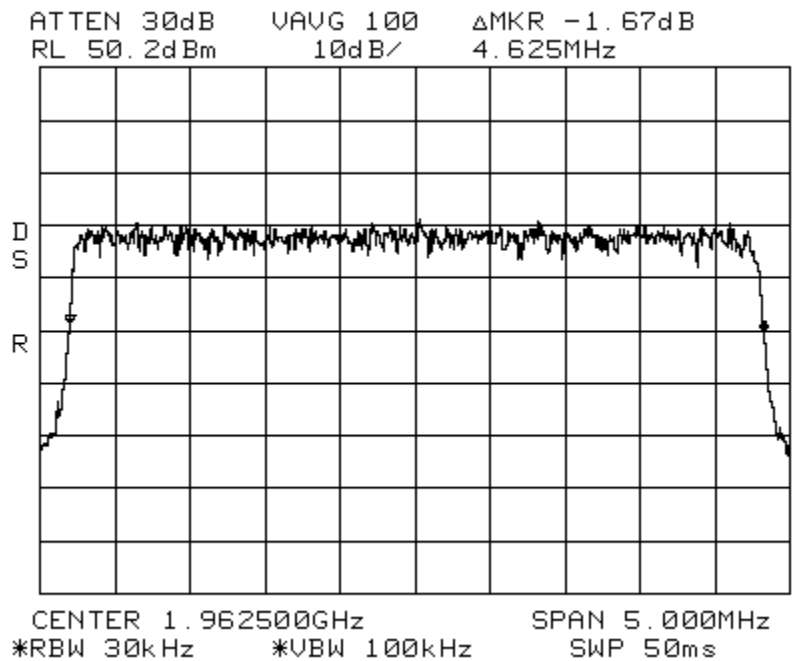



Occupied Bandwidth

LTE 10 MHz Channel Bandwidth\_Signal\_In

PCS 20W

Span: 10 MHz

RBW: 30 kHz VBW: 100 kHz

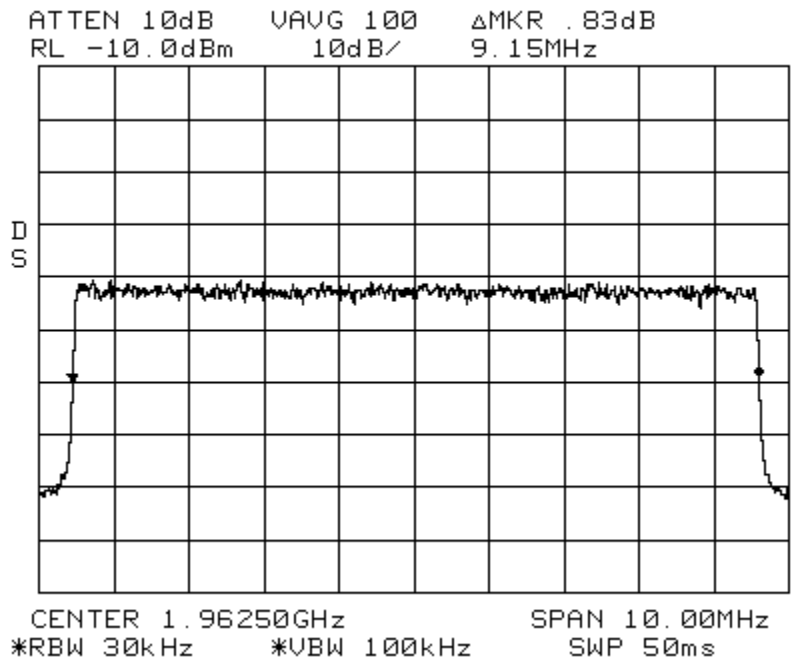

Occupied Bandwidth

LTE 10 MHz Channel Bandwidth\_Signal\_Out

PCS 20W

Span: 10 MHz

RBW: 30 kHz VBW: 100 kHz

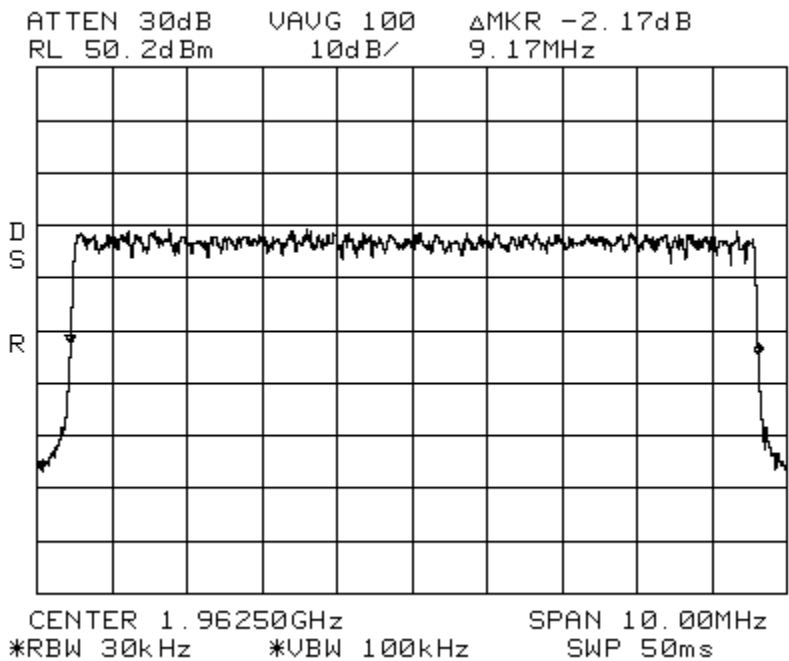

Occupied Bandwidth

LTE 15 MHz Channel Bandwidth\_Signal\_In

PCS 20W

Span: 15 MHz

RBW: 30 kHz VBW: 100 kHz

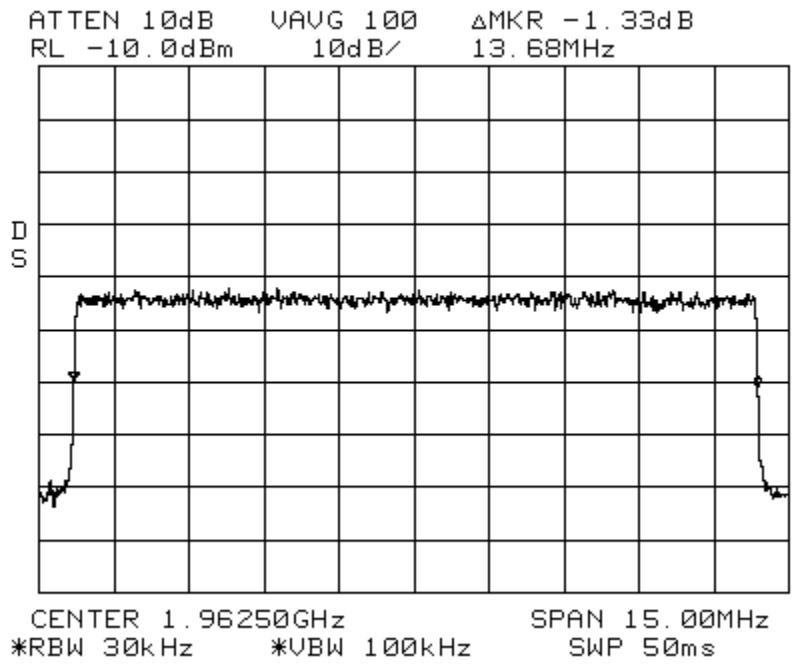

Occupied Bandwidth

LTE 15 MHz Channel Bandwidth\_Signal\_Out

PCS 20W

Span: 15 MHz

RBW: 30 kHz VBW: 100 kHz

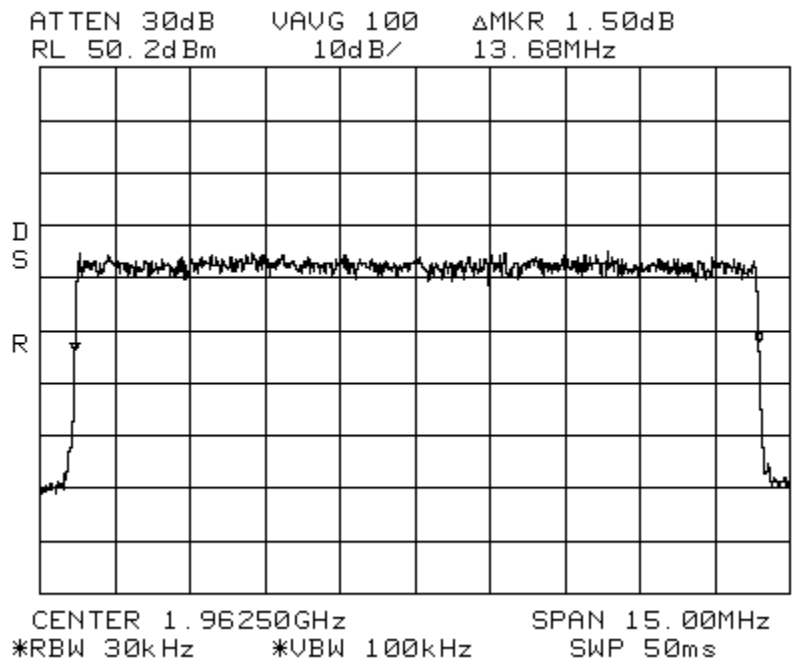

Occupied Bandwidth  
Span: 5 MHz

WCDMA\_Signal\_In  
RBW: 30 kHz VBW: 100 kHz

PCS 20W

ATTEN 10dB VAUG 100 ΔMKR .50dB  
RL -10.0dBm 10dB/ 4.567MHz

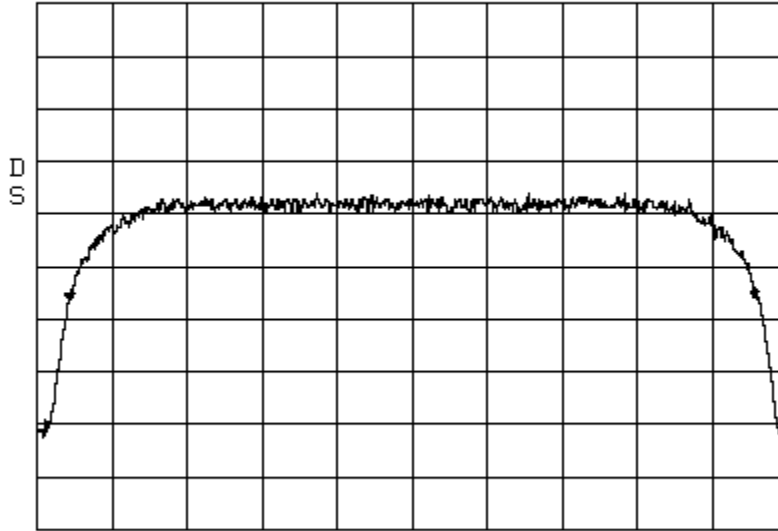

CENTER 1.96250GHz SPAN 5.000MHz  
\*RBW 30kHz \*VBW 100kHz SWP 50ms

Occupied Bandwidth  
Span: 5 MHz

WCDMA\_Signal\_Out  
RBW: 30 kHz VBW: 100 kHz

PCS 20W

ATTEN 30dB VAUG 100 ΔMKR 0dB  
RL 50.2dBm 10dB/ 4.558MHz

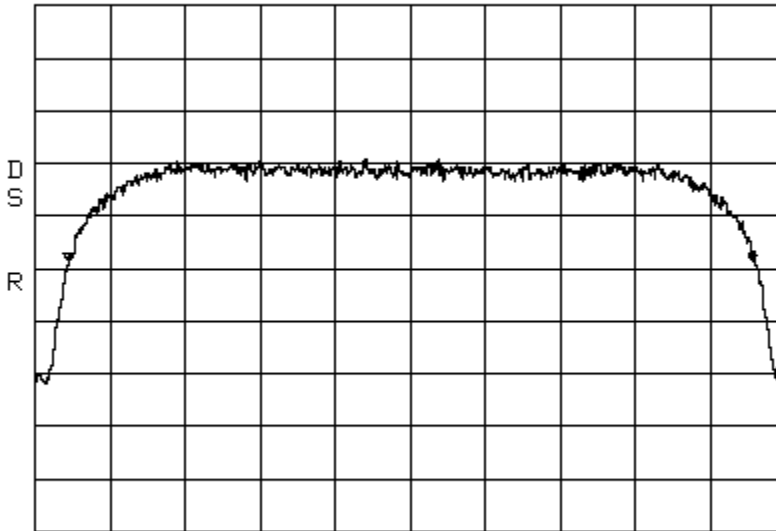

CENTER 1.96250GHz SPAN 5.000MHz  
\*RBW 30kHz \*VBW 100kHz \*SWP 50ms

### 6.3 FCC 2.1046, 22.913, & 24.232 Power Limits – Output Power

**Test Summary:**

- The requirements are:                    **• MET**                    ◦ NOT MET
- Minimum margin of compliance is 43.78 dB at 881.5 MHz (CDMA)
- Minimum margin of compliance is 43.68 dB at 881.5 MHz (GSM)
- Minimum margin of compliance is 44.10 dB at 881.5 MHz (EDGE)
- Minimum margin of compliance is 43.34 dB at 881.5 MHz (W-CDMA)
- Minimum margin of compliance is 43.45 dB at 881.5 MHz (LTE3MHz)
- Minimum margin of compliance is 43.14 dB at 881.5 MHz (LTE5MHz)
- Minimum margin of compliance is 43.16 dB at 881.5 MHz (LTE10MHz)
- Minimum margin of compliance is 43.12 dB at 1930.8 MHz (CDMA)
- Minimum margin of compliance is 43.10 dB at 1962.5 MHz (GSM)
- Minimum margin of compliance is 44.05 dB at 1962.5 MHz (EDGE)
- Minimum margin of compliance is 43.06 dB at 1962.5 MHz (W-CDMA)
- Minimum margin of compliance is 43.10 dB at 1993.5 MHz (LTE3MHz)
- Minimum margin of compliance is 43.25 dB at 1962.5 MHz (LTE5MHz)
- Minimum margin of compliance is 43.20 dB at 1962.5 MHz (LTE10MHz)
- Minimum margin of compliance is 43.04 dB at 1962.5 MHz (LTE15MHz)

**Test Methods Used:**

TIA-603-C 2004, ANSI C63.4-2003, FCC 2.1046, 22.913, & 24.232

**Test Procedure:**

Conducted: The RF Output of the transmitter was connected to the input of the spectrum analyzer through sufficient attenuation.

This measurement was made as a direct conducted emission measurement. The output from the EUT antenna connector was connected to the power meter. The carrier output, below, was conducted using a single GSM, EDGE, CDMA, WCDMA, LTE 3 MHz, LTE 5MHz, LTE 10MHz, LTE 15MHz Channel Bandwidths & signal generator.

A signal was used at the low, mid and high parts of the selected band.

**Test Limit:**

100 Watts or 50 dBm Limit

**Test Date: 10/30/12**

**Tests Conducted By: Joshua J. Wittman**

**Test Equipment: 2, 6, 9, 12, 13**

Number	Description	Manufacturer	Model	ADC TELECOMMUNICATIONS Serial Number	Cal Due	Used
2	Power Meter	HP	437B	MC27754	6-30-13	<input checked="" type="checkbox"/>
6	Signal Generator	Aeroflex	3413	MC57343	11-9-12	<input checked="" type="checkbox"/>
9	Digital Barometer	Fisher Scientific	02-403	MC50719	1-25-13	<input checked="" type="checkbox"/>
12	RF Power Sensor	Agilent	8481A	MC48747	6-30-13	<input checked="" type="checkbox"/>
13	Spectrum Analyzer	Rohde & Schwarz	FSQ-8	MC57131	2-15-13	<input checked="" type="checkbox"/>

**Environmental Conditions in the lab:**

**Temperature:** 28° C

**Relative Humidity:** 20%

**Atmospheric Pressure:** 99.0 kPa

**Test Results:**

**CELL**

**CDMA** 23.878 Watts

Carrier Frequency	Carrier Output
869.8 MHz	<u>42.60</u> dBm
881.5 MHz	<u>43.78</u> dBm
893.2 MHz	<u>42.73</u> dBm

**CELL**

**GSM** 23.014 Watts

Carrier Frequency	Carrier Output
869.2 MHz	<u>42.62</u> dBm
881.5 MHz	<u>43.62</u> dBm
893.8 MHz	<u>42.57</u> dBm

**CELL**

**EDGE** 25.703 Watts

Carrier Frequency	Carrier Output
869.2 MHz	<u>43.04</u> dBm
881.5 MHz	<u>44.10</u> dBm
893.8 MHz	<u>43.06</u> dBm

**CELL**

**WCDMA** 21.577 Watts

Carrier Frequency	Carrier Output
871.5 MHz	<u>42.45</u> dBm
881.5 MHz	<u>43.34</u> dBm
891.5 MHz	<u>42.35</u> dBm

**CELL**

**LTE 3.0 MHz** 22.130 Watts

Carrier Frequency	Carrier Output
870.5 MHz	<u>42.80</u> dBm
881.5 MHz	<u>43.45</u> dBm
892.5 MHz	<u>42.40</u> dBm

**CELL**

**LTE 5.0 MHz** 20.606 Watts

Carrier Frequency	Carrier Output
871.5 MHz	<u>42.10</u> dBm
881.5 MHz	<u>43.14</u> dBm
891.5 MHz	<u>42.05</u> dBm

**CELL**

**LTE 10.0 MHz** 20.701 Watts

Carrier Frequency	Carrier Output
874.0 MHz	<u>42.54</u> dBm
881.5 MHz	<u>43.16</u> dBm
889.0 MHz	<u>42.47</u> dBm

PCS  
**CDMA** **20.511 Watts**

Carrier Frequency	Carrier Output
1930.8 MHz	<u>43.12</u> dBm
1962.5 MHz	<u>43.03</u> dBm
1994.2 MHz	<u>42.62</u> dBm

PCS  
**GSM** **20.417 Watts**

Carrier Frequency	Carrier Output
1930.2 MHz	<u>42.15</u> dBm
1962.5 MHz	<u>43.10</u> dBm
1994.8 MHz	<u>42.74</u> dBm

PCS  
**EDGE** **25.409 Watts**

Carrier Frequency	Carrier Output
1930.2 MHz	<u>43.13</u> dBm
1962.5 MHz	<u>44.05</u> dBm
1994.8 MHz	<u>43.07</u> dBm

PCS  
**WCDMA** **20.230 Watts**

Carrier Frequency	Carrier Output
1932.5 MHz	<u>42.83</u> dBm
1962.5 MHz	<u>43.06</u> dBm
1992.5 MHz	<u>42.81</u> dBm

PCS  
**LTE 3.0 MHz** **20.417 Watts**

Carrier Frequency	Carrier Output
1931.5 MHz	<u>42.30</u> dBm
1962.5 MHz	<u>43.01</u> dBm
1993.5 MHz	<u>43.10</u> dBm

PCS  
**LTE 5.0 MHz** **21.134 Watts**

Carrier Frequency	Carrier Output
1932.5 MHz	<u>42.72</u> dBm
1962.5 MHz	<u>43.25</u> dBm
1992.5 MHz	<u>43.05</u> dBm

PCS  
**LTE 10.0 MHz** **20.892 Watts**

Carrier Frequency	Carrier Output
1935.0 MHz	<u>43.11</u> dBm
1962.5 MHz	<u>43.20</u> dBm
1990.0 MHz	<u>43.10</u> dBm

PCS  
**LTE 15.0 MHz** **20.137 Watts**

Carrier Frequency	Carrier Output
1937.5 MHz	<u>41.40</u> dBm
1962.5 MHz	<u>43.04</u> dBm
1987.5 MHz	<u>41.45</u> dBm

## 6.4 FCC 2.1051, 22.917, & 24.238 Emissions Limits – Spurious Emissions at Antenna

### Test Summary:

- The requirements are:
  - **MET**
  - NOT MET

### Test Methods Used:

TIA-603-C 2004, ANSI C63.4-2003, FCC 2.1051, 22.917, & 24.238

### Test Procedure:

The RF Output of the transmitter was connected to input of the spectrum analyzer through sufficient attenuation.

The out of band emissions were measured directly from the EUT antenna output in the TX path using a spectrum analyzer from 30 MHz to the 10<sup>th</sup> harmonic of the highest carrier frequency. Test signals used are GSM, EDGE, CDMA, WCDMA, LTE 3 MHz, LTE 5MHz, LTE 10MHz, & LTE 15MHz Channel Bandwidths. The different signals were input one at a time to the EUT.

The inter-modulation products test was performed for the EUT. Three tests were performed with the modulation type. Test 1 was with 2 signals input to the EUT at lower end channels. Test 2 was with 2 signals input to the EUT at upper end channels. Test 3 was with 2 signals input to the EUT at upper and lower end channels. The modulation types tested were GSM, EDGE, CDMA, WCDMA, 3 MHz, 5MHz, 10MHz, & 15MHz Channel Bandwidths.

### Test Limit:

The spectrum shall be investigated to the tenth harmonics of the highest fundamental frequency as specified in FCC 2.1057

Out of band emissions:

Attenuated below the transmitting power (P) by a factor of at least  $43 + 10\log(P)$  dB, or  $-13$  dBm.

**Test Dates: 10/31/12, 11/1/12, 11/2/12, 11/6/12, 11/7/12, & 11/8/12**

**Tests Conducted By: Joshua J. Wittman**

**Test Equipment: 1, 2, 6, 7, 9, 12, 13**

Number	Description	Manufacturer	Model	ADC TELECOMMUNICATIONS Serial Number	Cal Due	Used
1	Spectrum Analyzer	HP	8563E	MC27690	6-30-13	<input checked="" type="checkbox"/>
2	Power Meter	HP	437B	MC27754	6-30-13	<input checked="" type="checkbox"/>
6	Signal Generator	Aeroflex	3413	MC57343	2-9-13	<input checked="" type="checkbox"/>
7	Signal Generator	Aeroflex	3413	MC57947	6-26-14	<input checked="" type="checkbox"/>
9	Digital Barometer	Fisher Scientific	02-403	MC50719	1-25-13	<input checked="" type="checkbox"/>
12	RF Power Sensor	Agilent	8482A	MC48747	6-30-13	<input checked="" type="checkbox"/>
13	Spectrum Analyzer	Rohde & Schwarz	FSQ-8	MC57131	2-15-13	<input checked="" type="checkbox"/>

### Environmental Conditions in the lab:

**Temperature:** 28° C

**Relative Humidity:** 20%

**Atmospheric Pressure:** 99.0 kPa

**Test Results:**

Conducted Emissions      CDMA      CELL 20 W  
Center: 881.5 MHz    Span: 5 MHz      RBW/VBW: 100 kHz

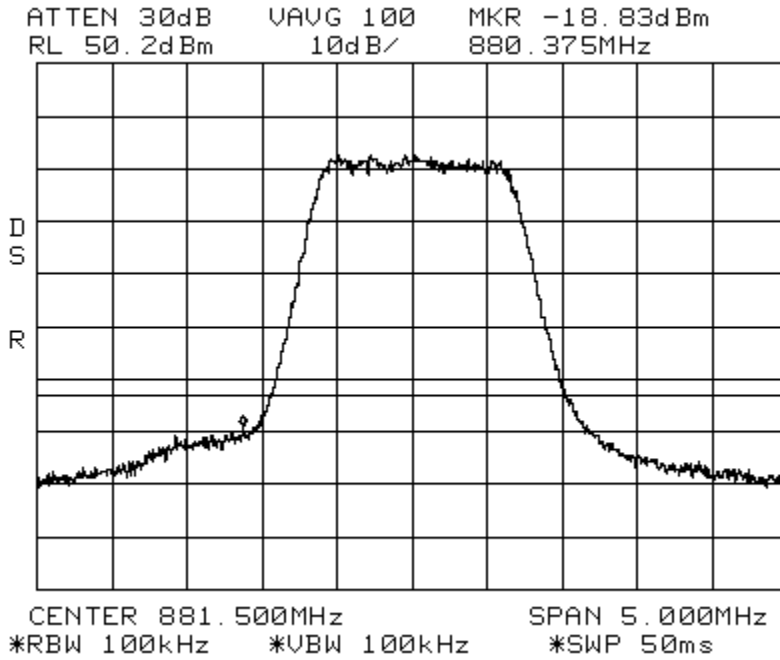

Conducted Emissions      CDMA      CELL 20 W  
Span: 30 MHz to 1 GHz      RBW/VBW: 300 kHz

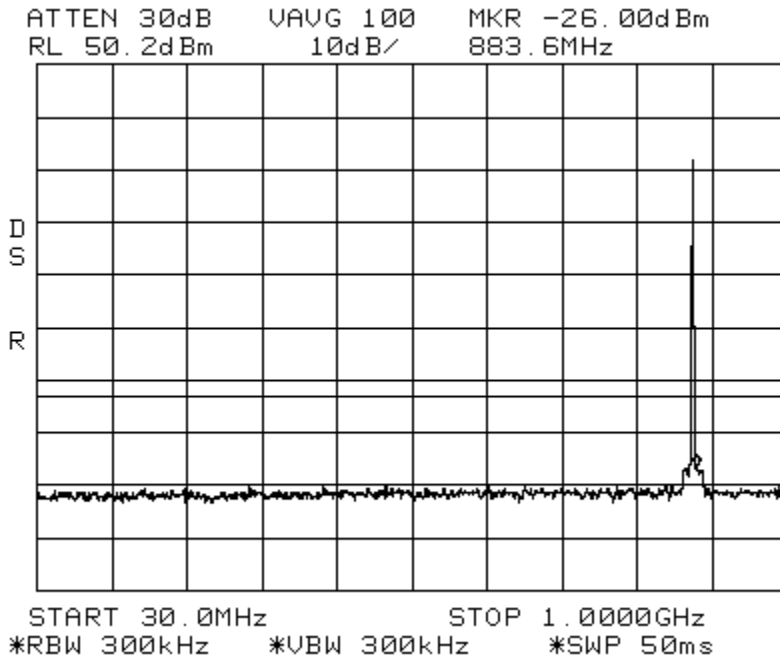



Conducted Emissions  
Span: 1 GHz to 10 GHz

CDMA

CELL 20 W  
RBW/VBW: 1 MHz

ATTEN 30dB VAUG 100 MKR -23.83dBm  
RL 50.2dBm 10dB/ 2.590GHz

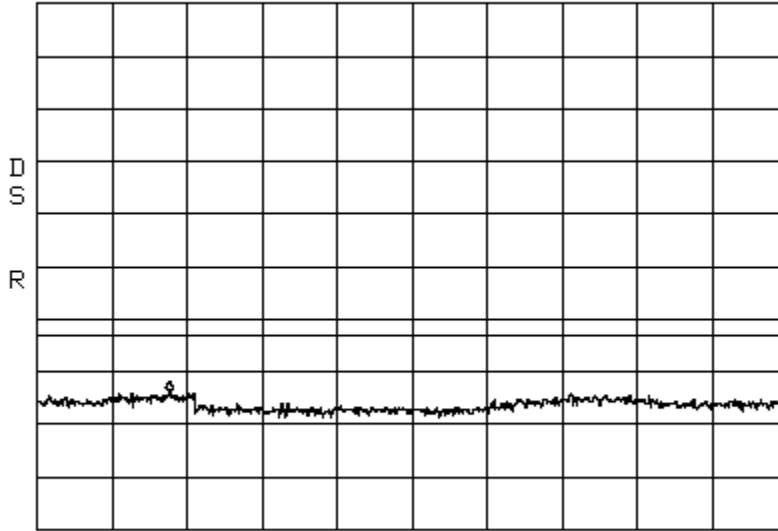

START 1.000GHz STOP 10.000GHz  
\*RBW 1.0MHz \*VBW 1.0MHz SWP 180ms

Conducted Emissions  
Center: 881.5 MHz Span: 5 MHz

EDGE  
CELL 20 W  
RBW/VBW: 100 kHz

ATTEN 30dB VAUG 100 MKR -29.50dBm  
RL 50.2dBm 10dB/ 879.975MHz

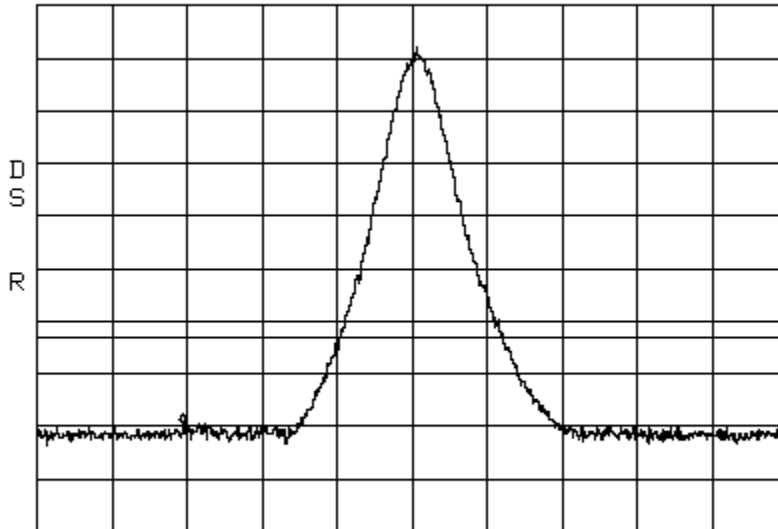

CENTER 881.500MHz SPAN 5.000MHz  
\*RBW 100kHz \*VBW 100kHz SWP 50ms

Conducted Emissions  
Span: 30 MHz to 1 GHz

EDGE

CELL 20 W  
RBW/VBW: 300 kHz

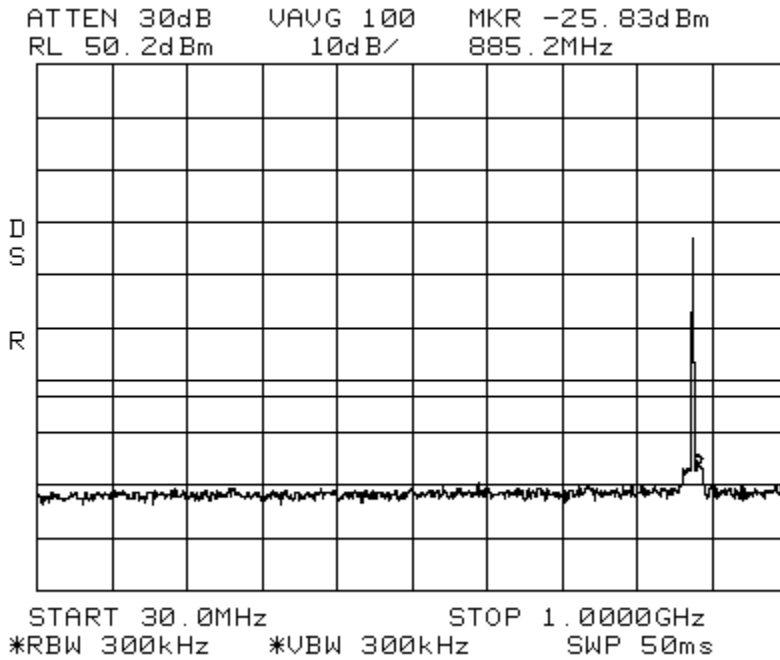

Conducted Emissions  
Span: 1 GHz to 10 GHz

EDGE

CELL 20 W  
RBW/VBW: 1 MHz

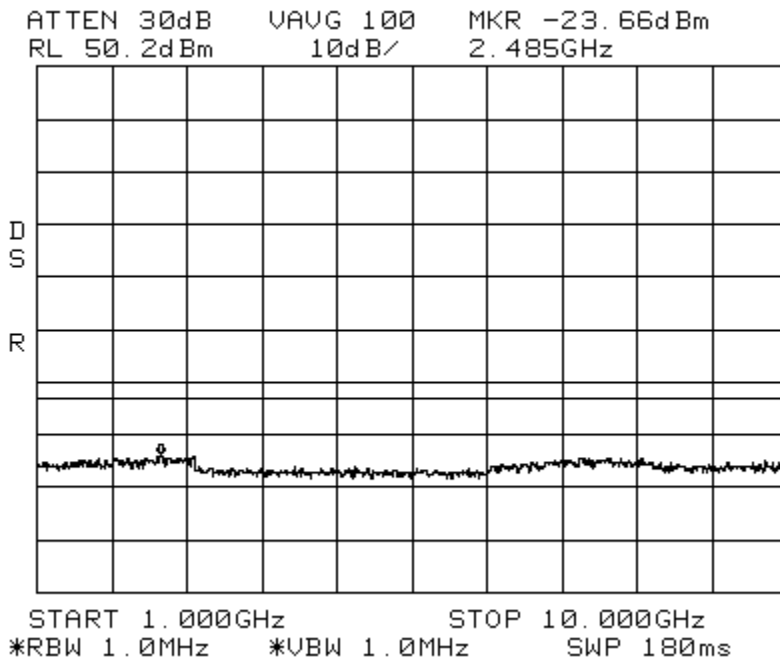

Conducted Emissions  
Center: 881.5 MHz

GSM  
Span: 5 MHz

CELL 20W  
RBW/VBW: 100 kHz

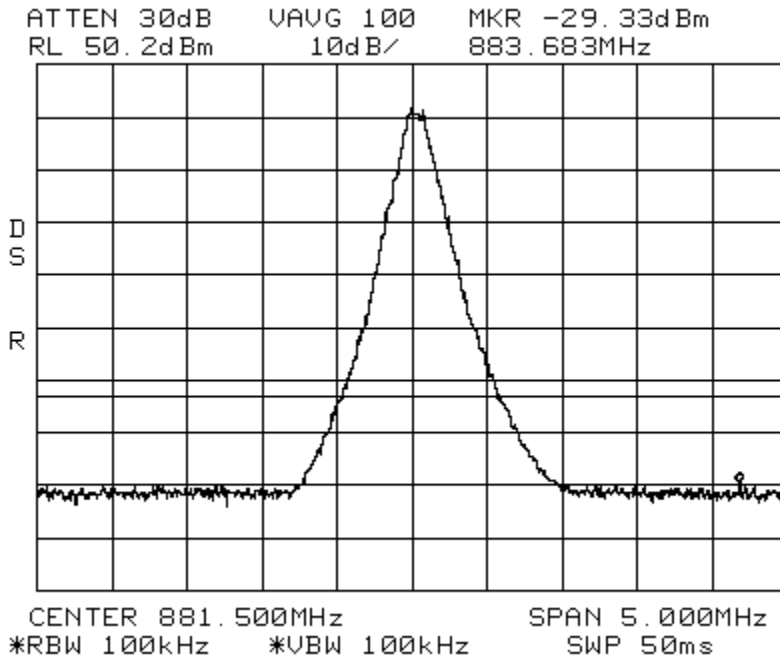

Conducted Emissions  
Span: 30 MHz to 1 GHz

GSM

CELL 20W  
RBW/VBW: 300 kHz

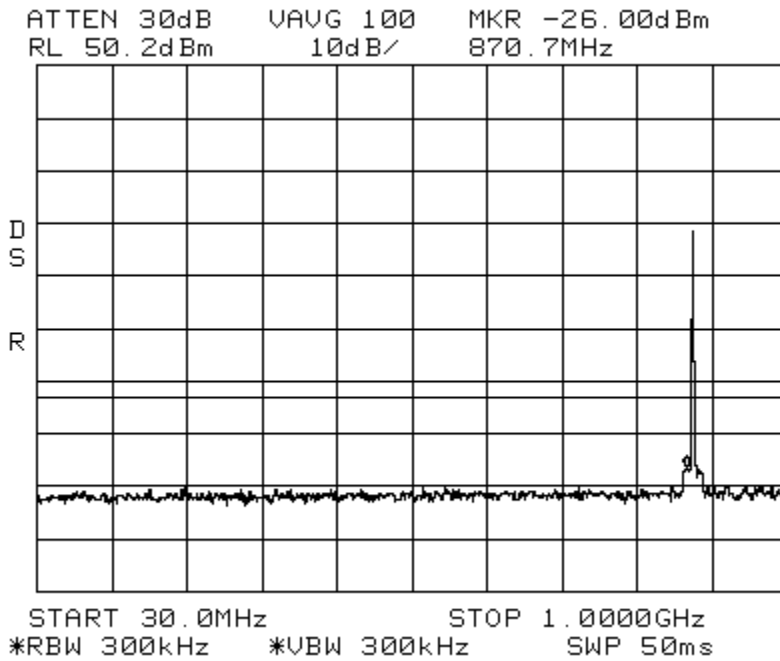

Conducted Emissions  
Span: 1 GHz to 10 GHz

GSM

CELL 20W  
RBW/VBW: 1 MHz

ATTEN 30dB VAUG 100 MKR -23.83dBm  
RL 50.2dBm 10dB/ 2.770GHz

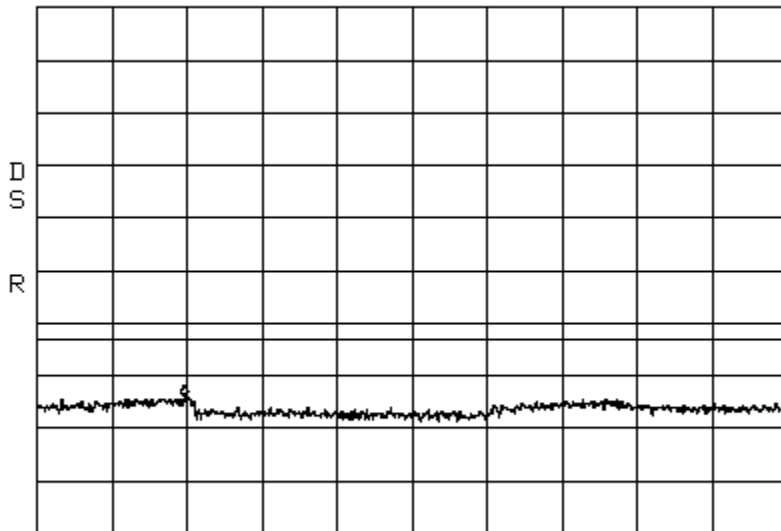

START 1.000GHz STOP 10.000GHz  
\*RBW 1.0MHz \*VBW 1.0MHz SWP 180ms

Conducted Emissions

LTE 3 MHz Channel Bandwidth

CELL 20W

Center: 881.5 MHz

Span: 5 MHz

RBW/VBW: 100 kHz

ATTEN 30dB VAUG 100 MKR -20.16dBm  
RL 50.2dBm 10dB/ 879.617MHz

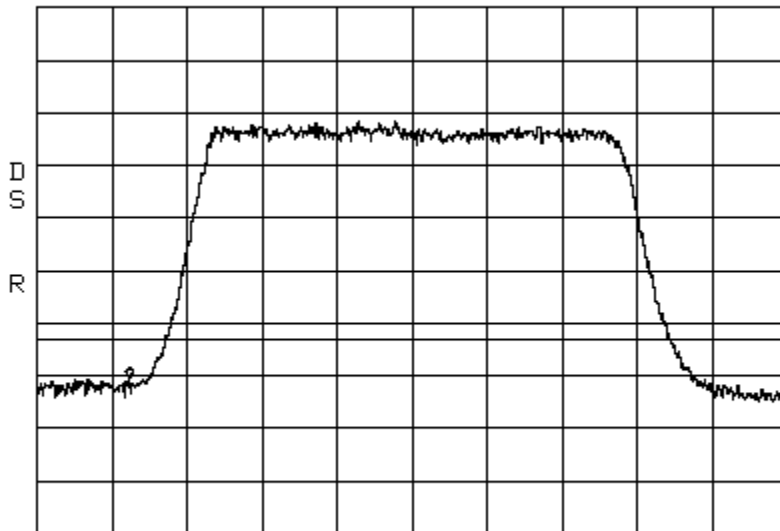

CENTER 881.500MHz SPAN 5.000MHz  
\*RBW 100kHz \*VBW 100kHz SWP 50ms

Conducted Emissions

LTE 3 MHz Channel Bandwidth

CELL 20W

Span: 30 MHz to 1 GHz

RBW/VBW: 300 kHz

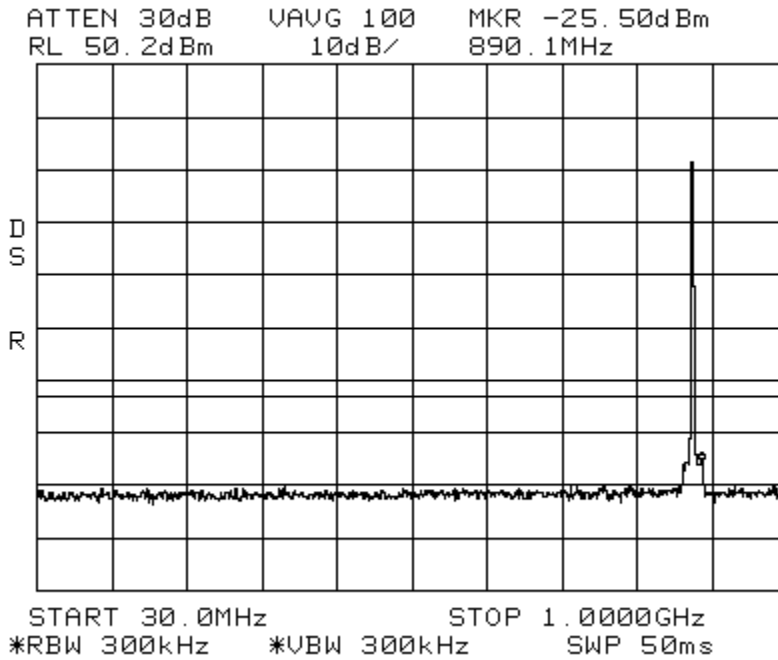

Conducted Emissions

LTE 3 MHz Channel Bandwidth

CELL 20W

Span: 1 GHz to 10 GHz

RBW/VBW: 1 MHz

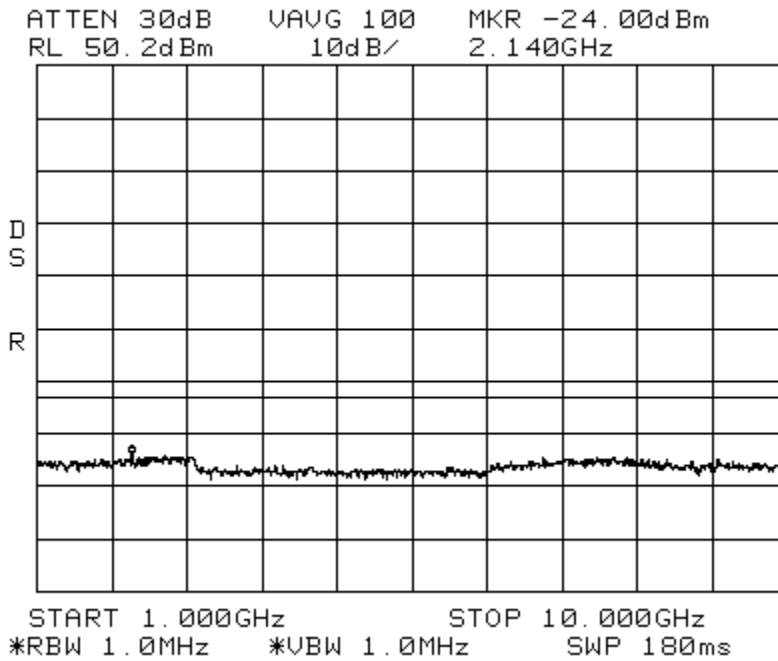

Conducted Emissions  
Center: 881.5 MHz

LTE 5 MHz Channel Bandwidth  
Span: 10 MHz

CELL 20W  
RBW/VBW: 100 kHz

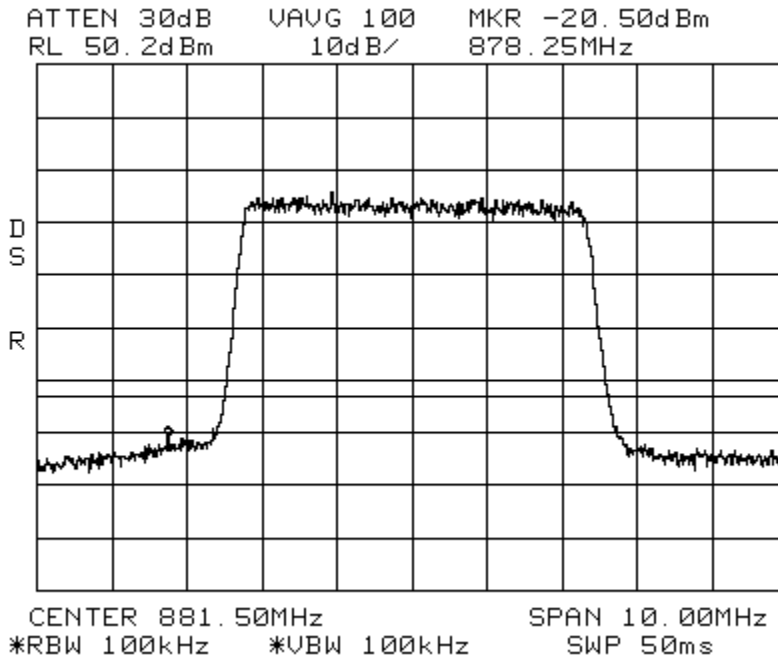

Conducted Emissions  
Span: 30 MHz to 1 GHz

LTE 5 MHz Channel Bandwidth  
RBW/VBW: 300 kHz

CELL 20W

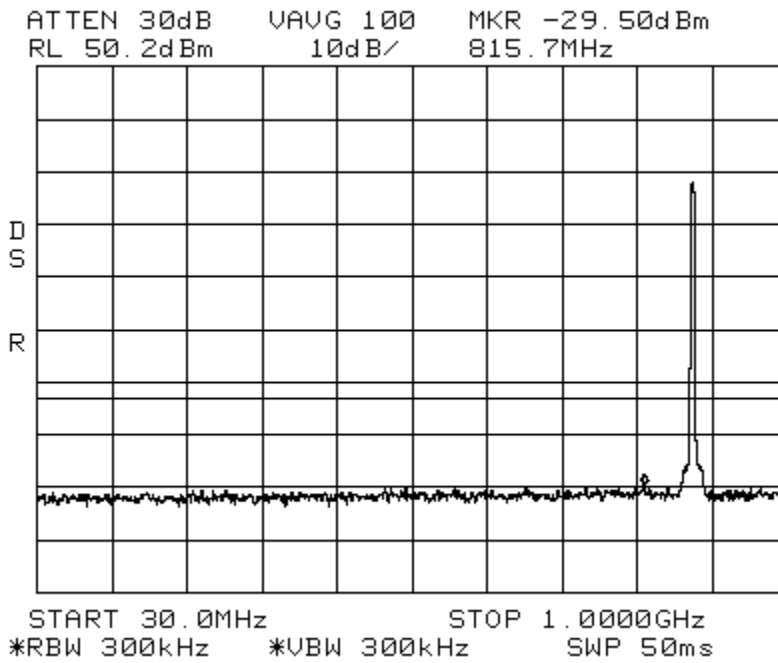

Conducted Emissions      LTE 5 MHz Channel Bandwidth      CELL 20W  
 Span: 1 GHz to 10 GHz      RBW/VBW: 1 MHz

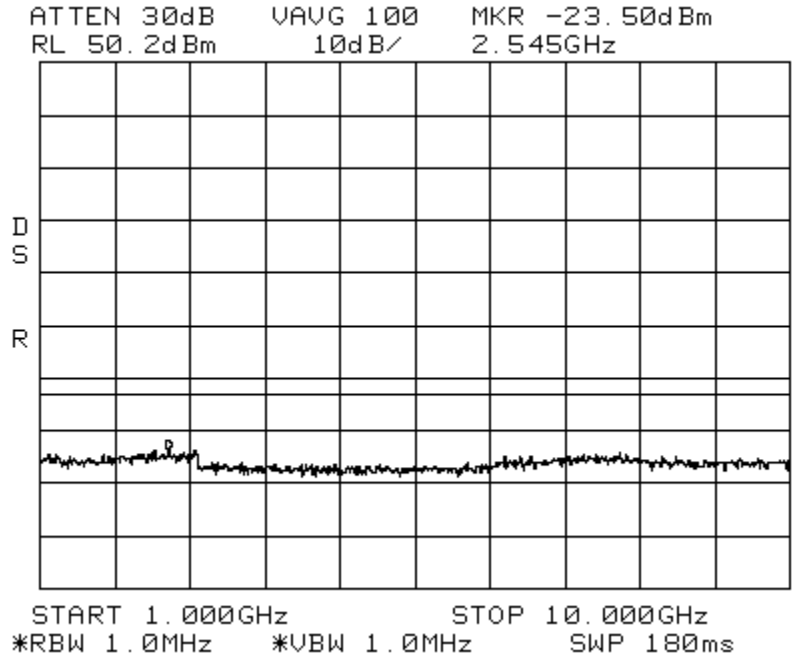

Conducted Emissions      LTE 10 MHz Channel Bandwidth      CELL 20W  
 Center: 881.5 MHz      Span: 20MHz      RBW/VBW: 100 kHz

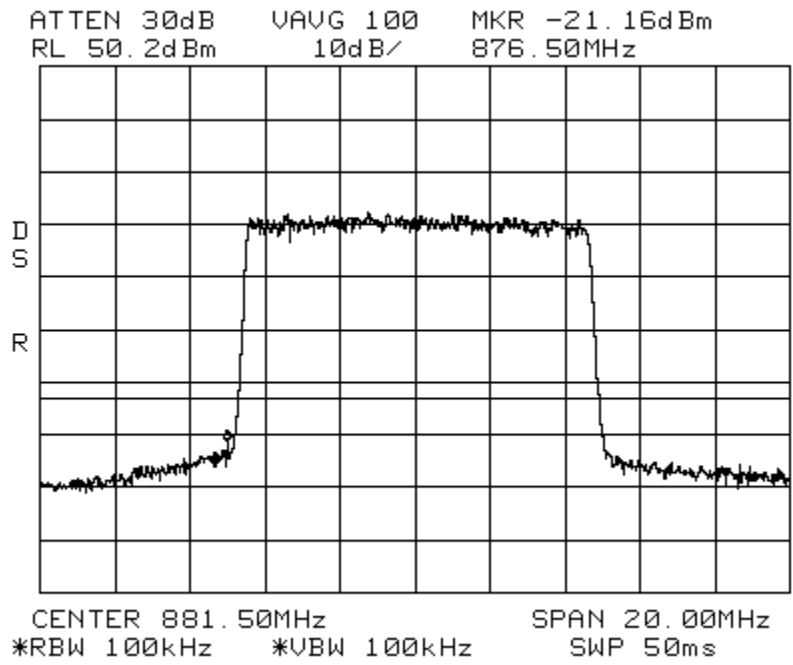

Conducted Emissions

LTE 10 MHz Channel Bandwidth

CELL 20W

Span: 30 MHz to 1 GHz

RBW/VBW: 300 kHz

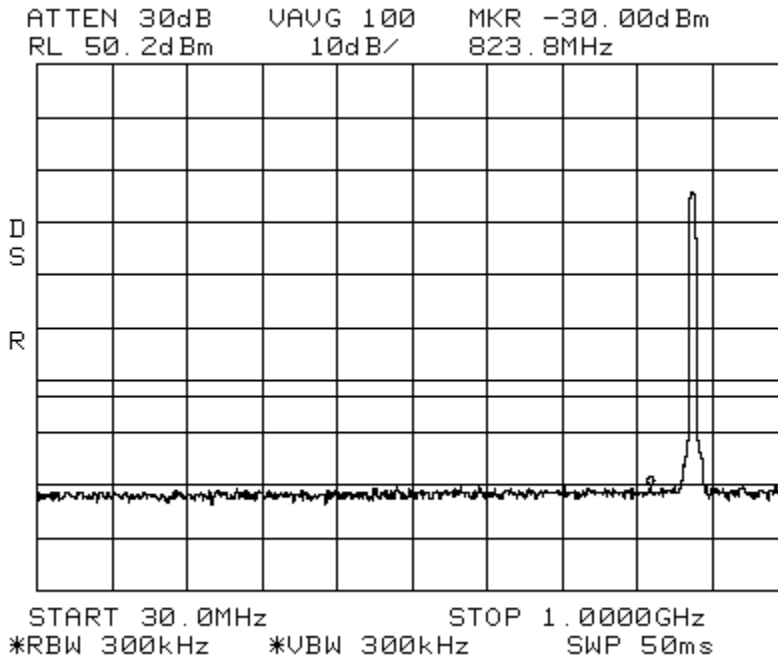

Conducted Emissions

LTE 10 MHz Channel Bandwidth

CELL 20W

Span: 1 GHz to 10 GHz

RBW/VBW: 1 MHz

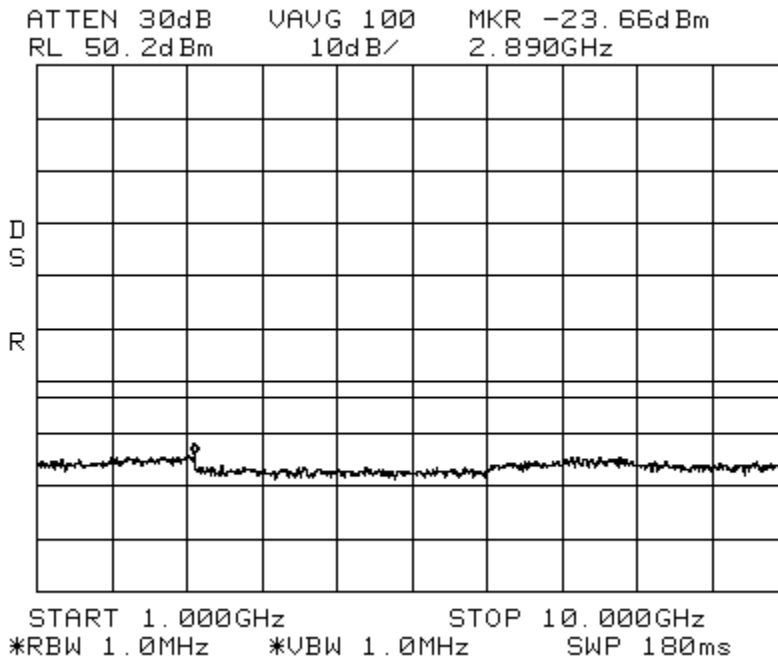



Conducted Emissions      WCDMA      CELL 20W  
 Center: 881.5 MHz      Span: 10 MHz      RBW/VBW: 100 kHz  
 ATTEN 30dB      VAVG 100      MKR -20.83dBm  
 RL 50.2dBm      10dB/      878.80MHz

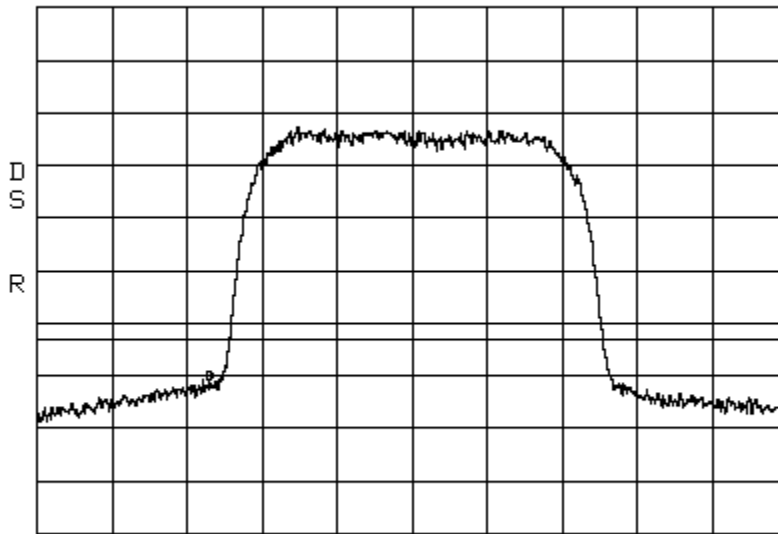

CENTER 881.50MHz      SPAN 10.00MHz  
 \*RBW 100kHz      \*VBW 100kHz      SWP 50ms

Conducted Emissions      WCDMA      CELL 20W  
 Span: 30 MHz to 1 GHz      RBW/VBW: 300 kHz  
 ATTEN 30dB      VAVG 100      MKR -30.00dBm  
 RL 50.2dBm      10dB/      830.3MHz

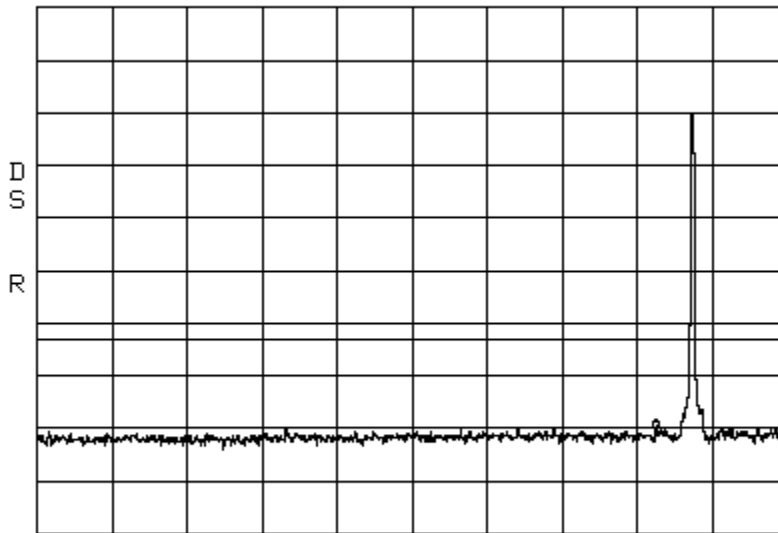

START 30.0MHz      STOP 1.0000GHz  
 \*RBW 300kHz      \*VBW 300kHz      SWP 50ms

Conducted Emissions  
Span: 1 GHz to 10 GHz

WCDMA

CELL 20W  
RBW/VBW: 1 MHz

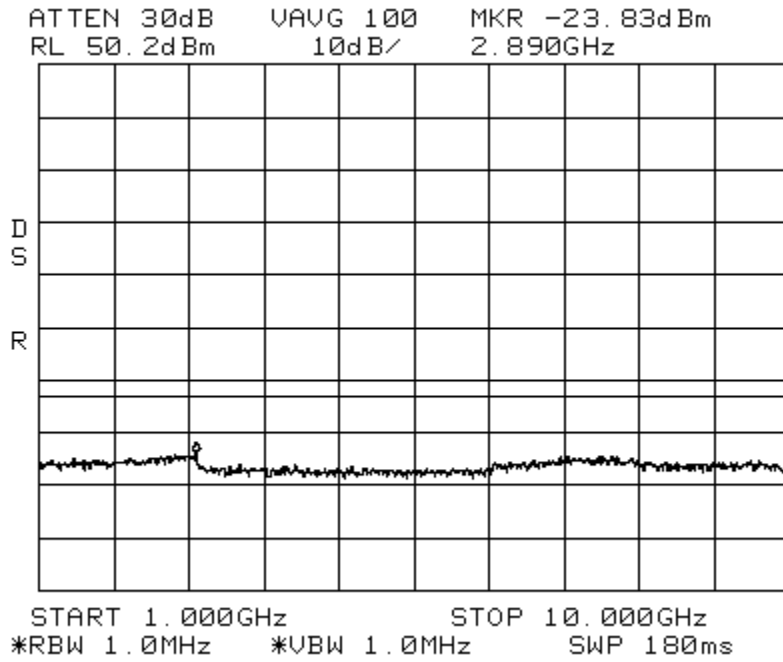

Conducted Emissions  
Center: 1962.5 MHz Span: 5 MHz

CDMA  
PCS 20W  
RBW/VBW: 100 kHz

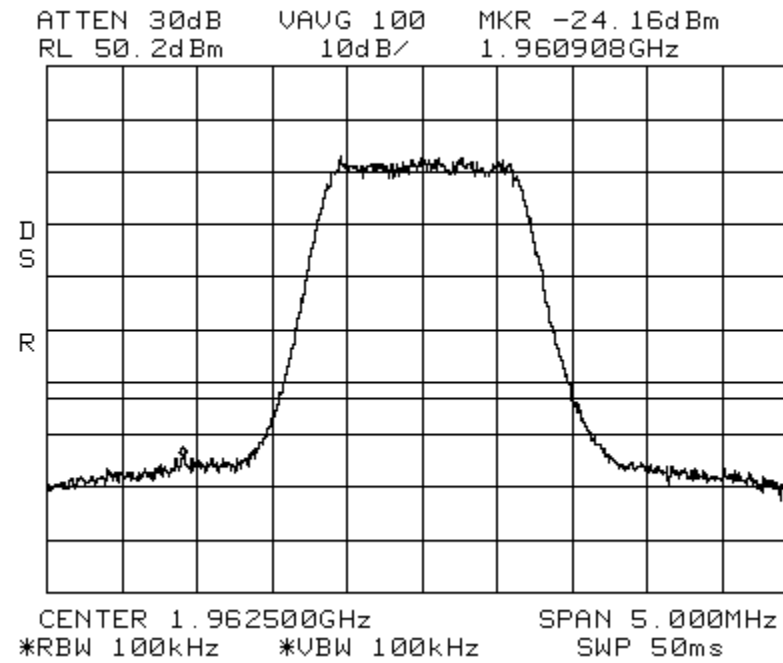

Conducted Emissions  
Span: 30 MHz to 1 GHz

CDMA PCS 20W  
RBW/VBW: 300 kHz

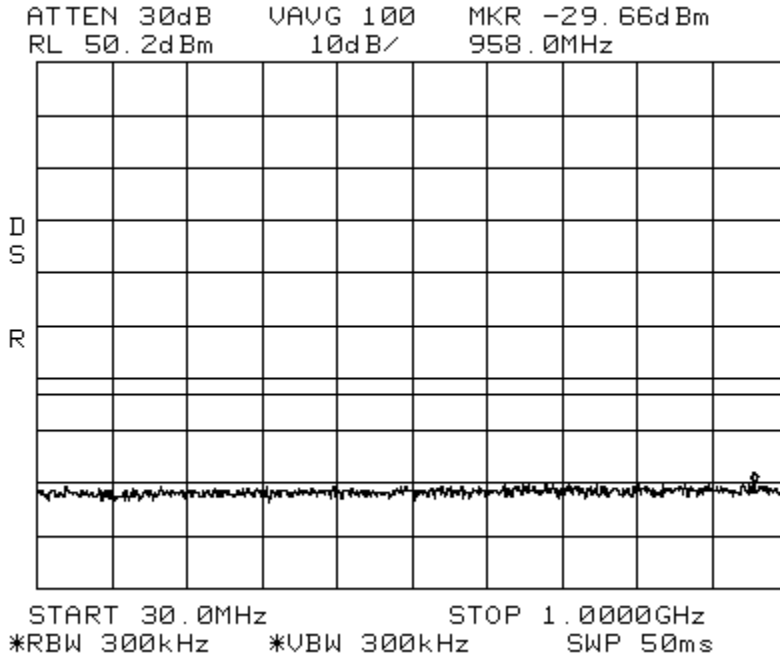

Conducted Emissions  
Span: 1 GHz to 5GHz

CDMA PCS 20W  
RBW/VBW: 1 MHz

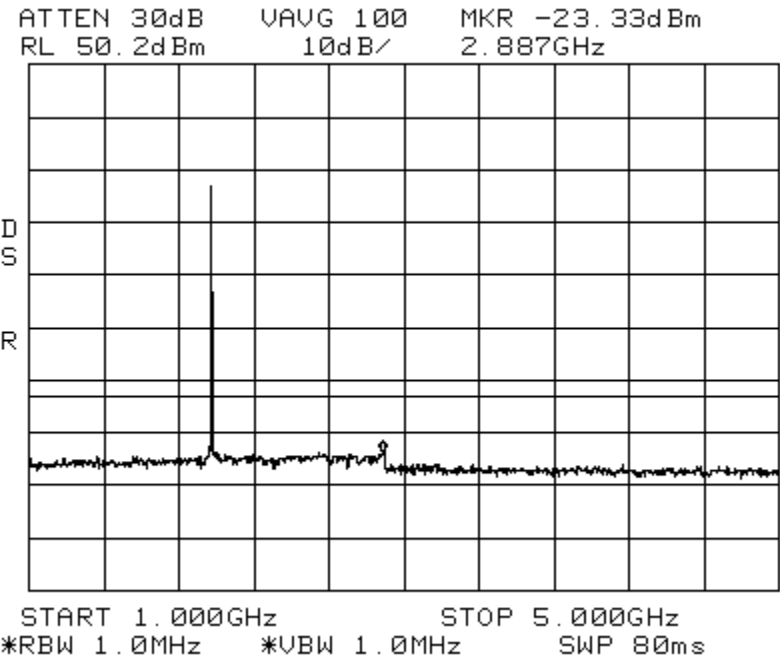

Conducted Emissions  
Span: 5 GHz to 20 GHz

CDMA

PCS 20W  
RBW/VBW: 1 MHz

ATTEN 30dB    VAUG 100    MKR -22.83dBm  
RL 50.2dBm    10dB/    14.95GHz

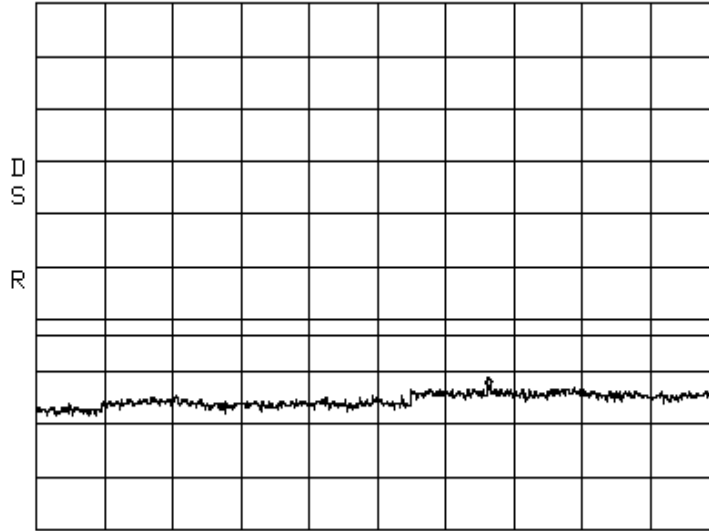

START 5.00GHz    STOP 20.00GHz  
\*RBW 1.0MHz    \*VBW 1.0MHz    SWP 300ms

Conducted Emissions  
Center: 1962.5 MHz

EDGE  
Span: 5 MHz

PCS 20W  
RBW/VBW: 100 kHz

ATTEN 30dB    VAUG 100    MKR -31.33dBm  
RL 50.2dBm    10dB/    1.961133GHz

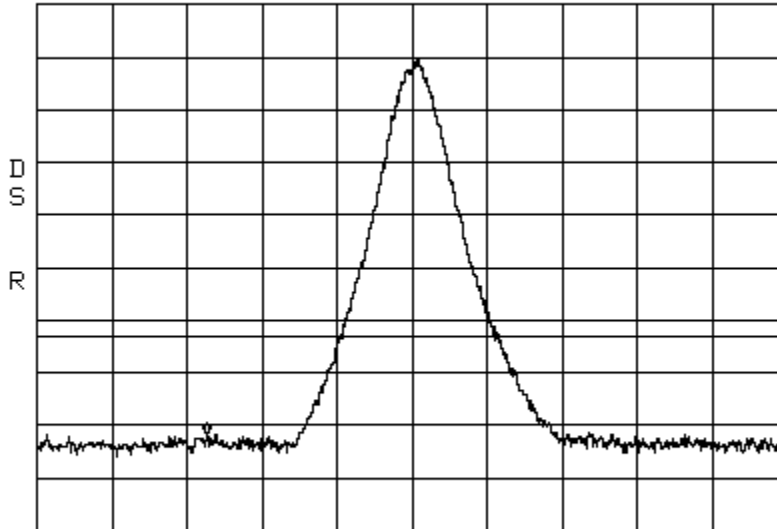

CENTER 1.962500GHz    SPAN 5.000MHz  
\*RBW 100kHz    \*VBW 100kHz    SWP 50ms

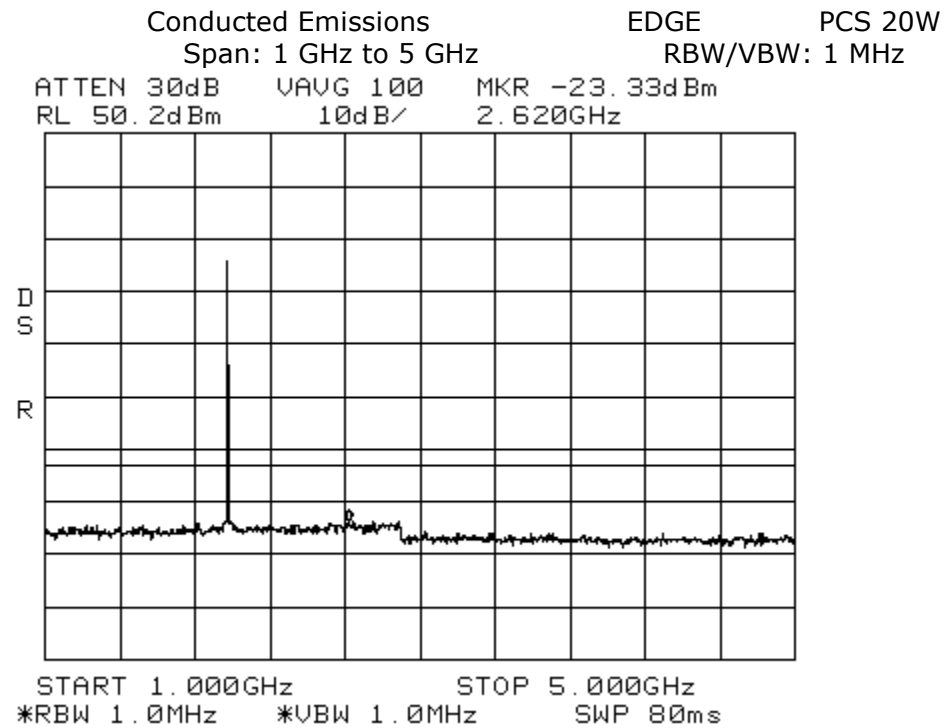
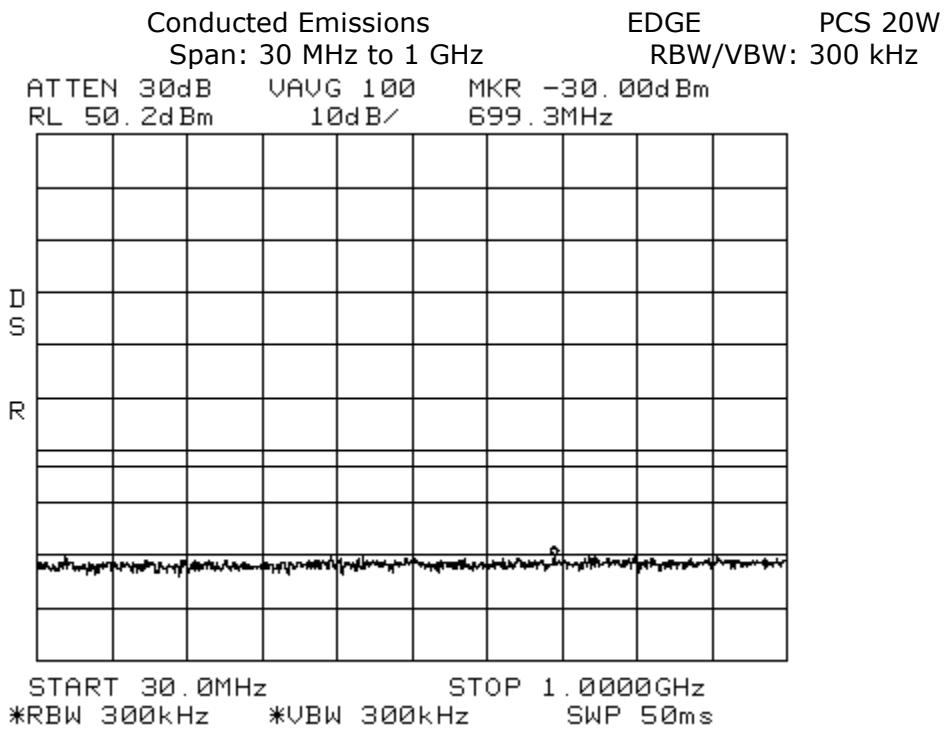

Conducted Emissions  
Span: 5 GHz to 20 GHz

EDGE PCS 20W  
RBW/VBW: 1 MHz

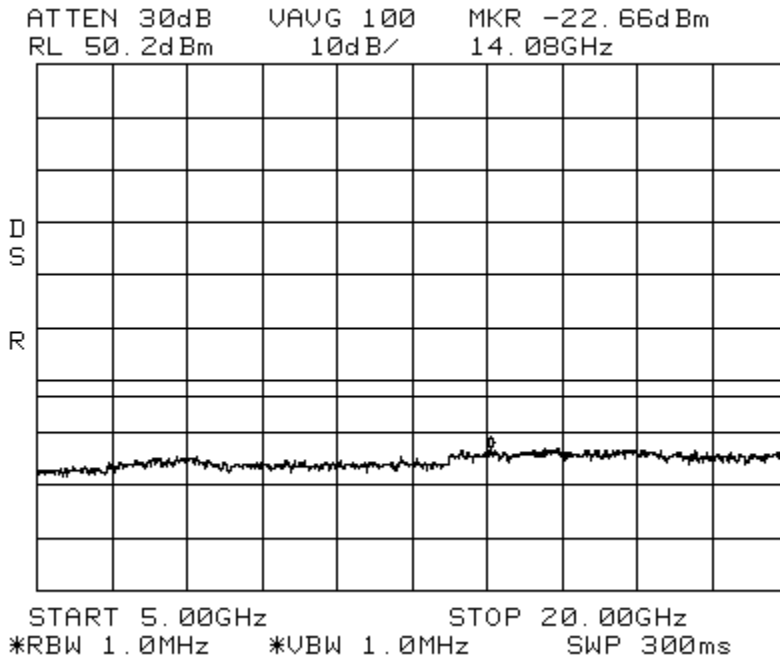

Conducted Emissions  
Center: 1962.5 MHz

GSM  
Span: 5 MHz

PCS 20W  
RBW/VBW: 100 kHz

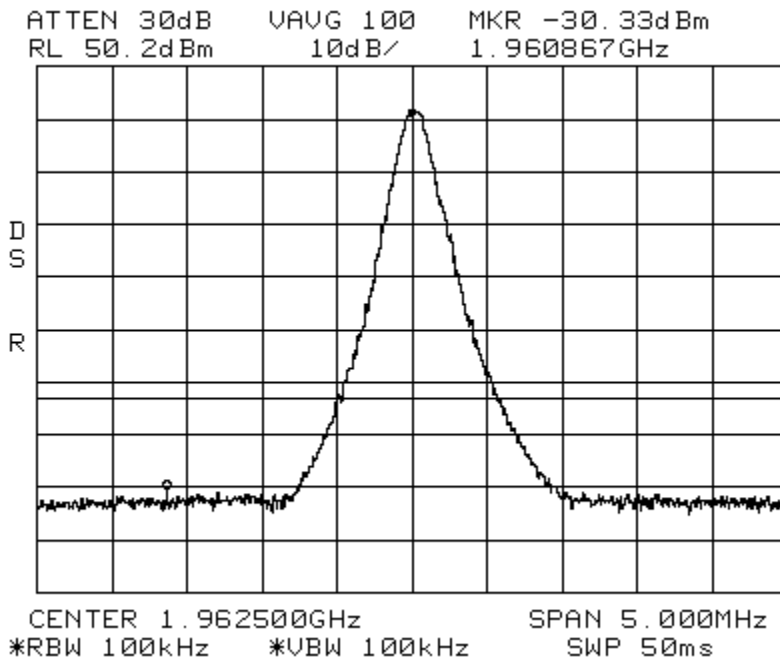

Conducted Emissions  
Span: 30 MHz to 1 GHz

GSM PCS 20W  
RBW/VBW: 300 kHz

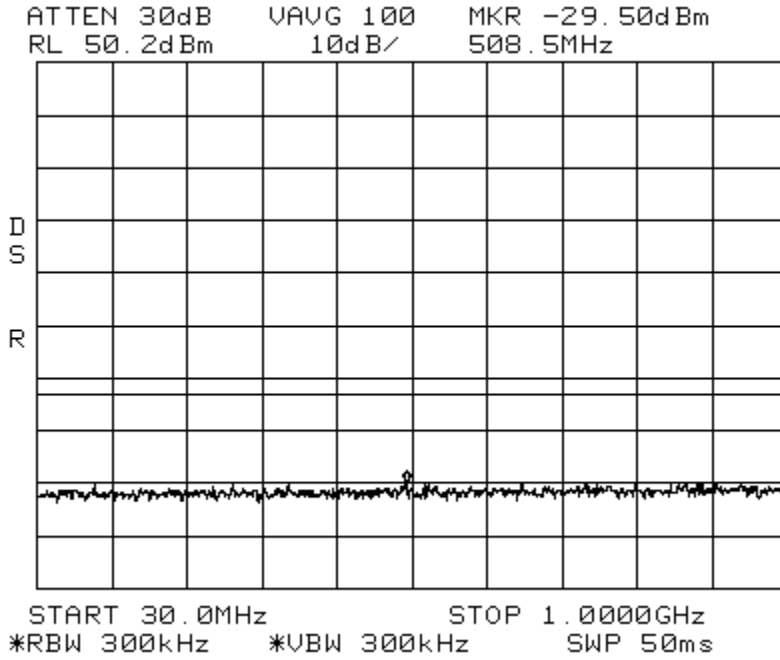

Conducted Emissions  
Span: 1 GHz to 5 GHz

GSM PCS 20W  
RBW/VBW: 1 MHz

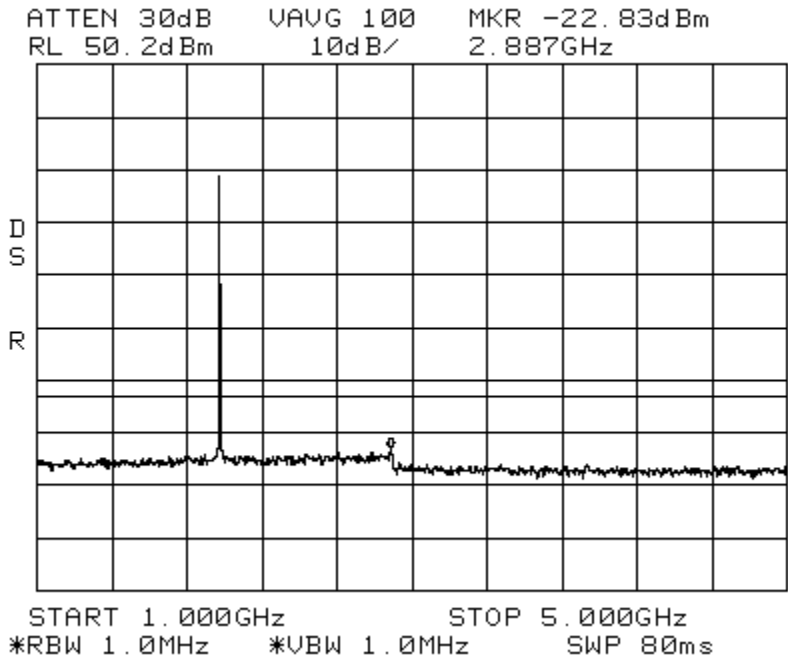

Conducted Emissions  
Span: 5 GHz to 20 GHz

GSM PCS 20W  
RBW/VBW: 1 MHz

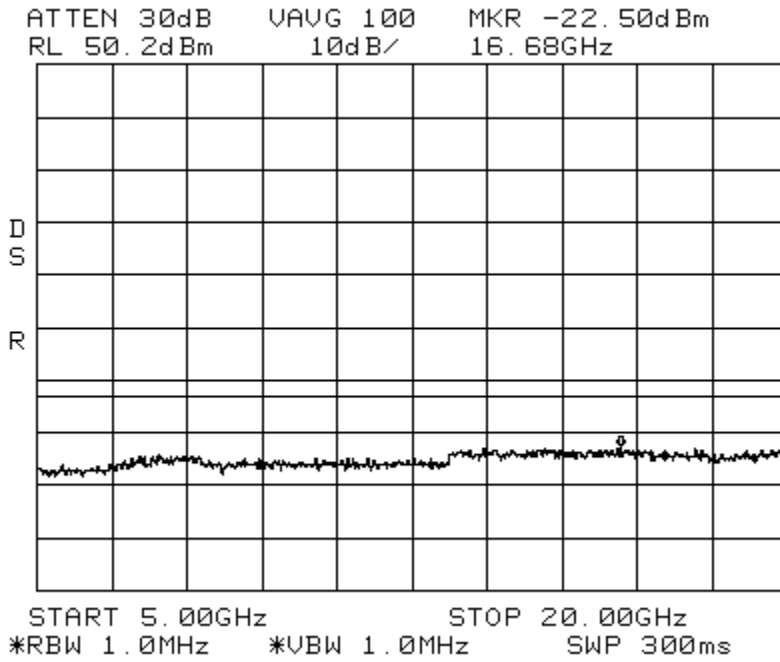

Conducted Emissions LTE 3 MHz Channel Bandwidth PCS 20W  
Center: 1962.5 MHz Span: 5 MHz RBW/VBW: 100 kHz  
ATTEN 30dB VAUG 100 MKR -23.16dBm  
RL 50.2dBm 10dB/ 1.964692GHz

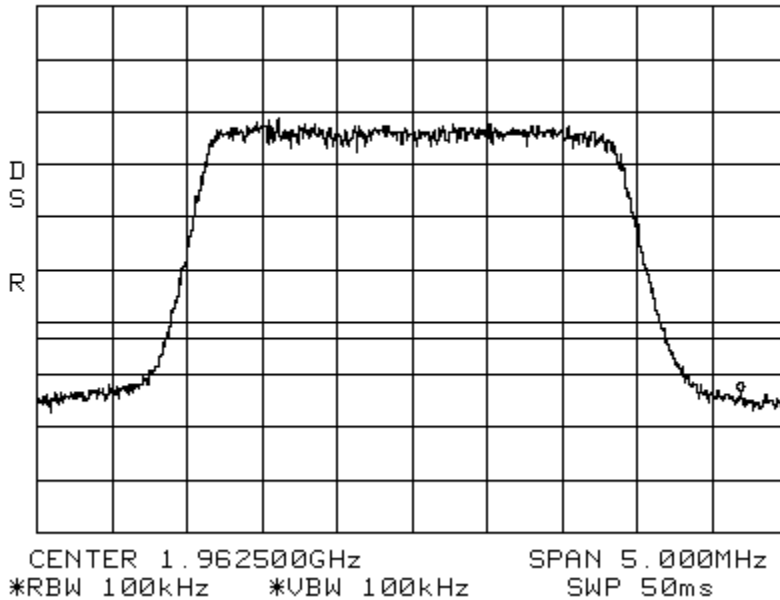



Conducted Emissions      LTE 3 MHz Channel Bandwidth      PCS 20W  
Span: 30 MHz to 1 GHz      RBW/VBW: 300 kHz

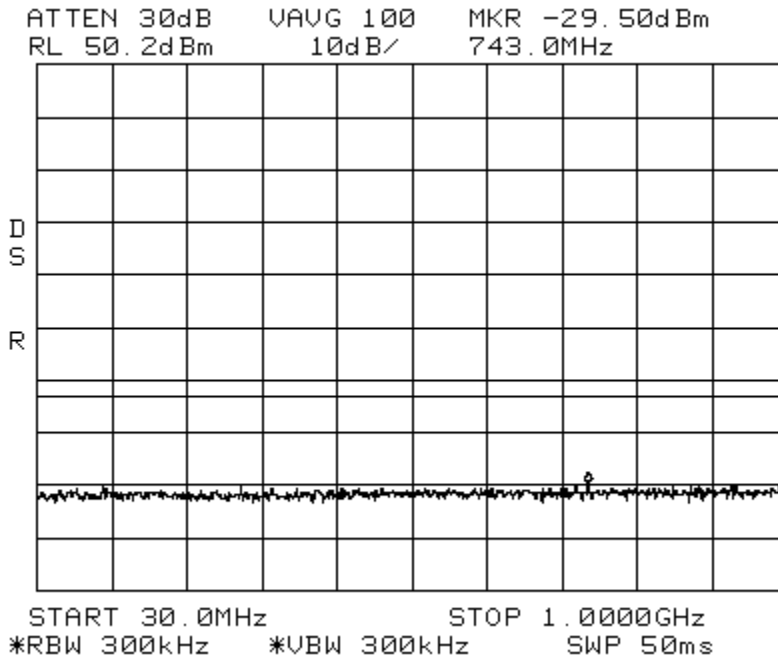

Conducted Emissions      LTE 3 MHz Channel Bandwidth      PCS 20W  
Span: 1 GHz to 5 GHz      RBW/VBW: 1 MHz

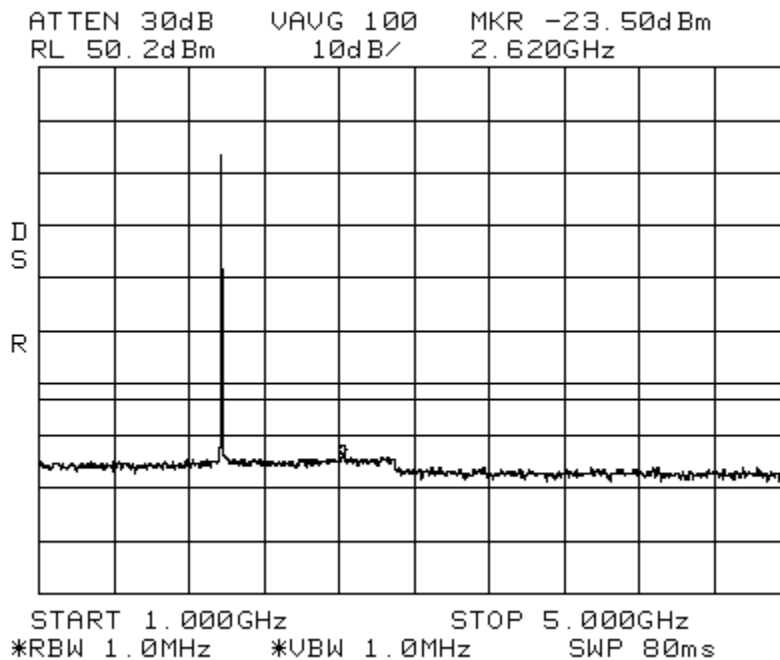

Conducted Emissions      LTE 3 MHz Channel Bandwidth      PCS 20W  
Span: 5 GHz to 20 GHz      RBW/VBW: 1 MHz

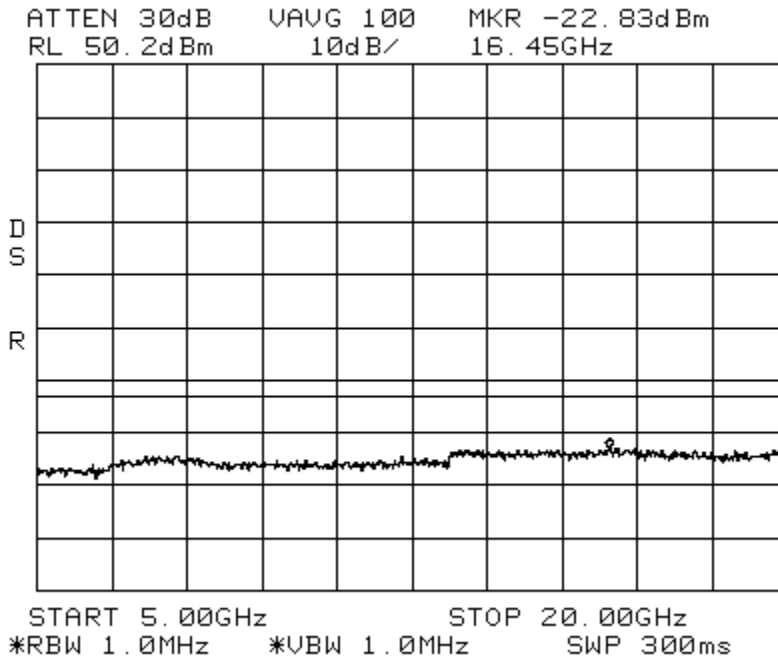

Conducted Emissions      LTE 5 MHz Channel Bandwidth      PCS 20W  
Center: 1962.5 MHz      Span: 10 MHz      RBW/VBW: 100 kHz

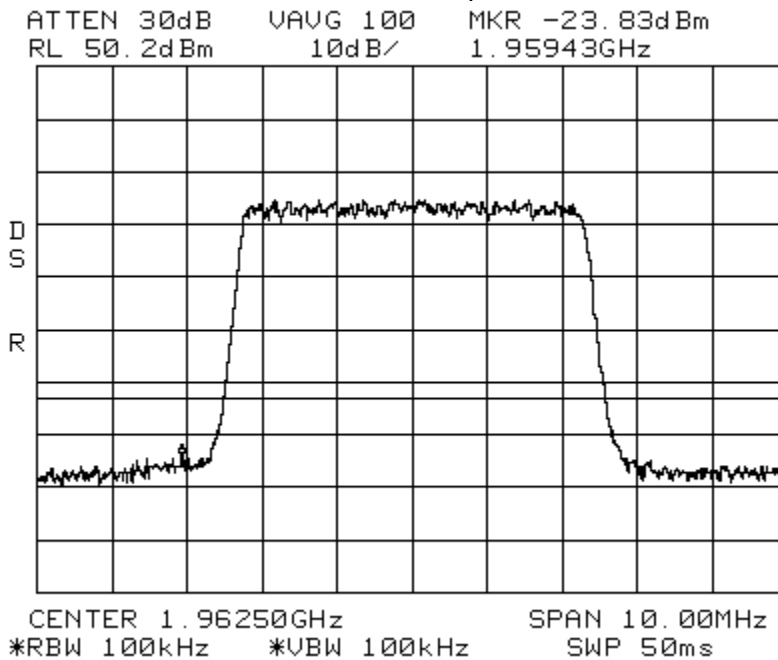

Conducted Emissions      LTE 5 MHz Channel Bandwidth      PCS 20W  
Span: 30 MHz to 1 GHz      RBW/VBW: 300 kHz

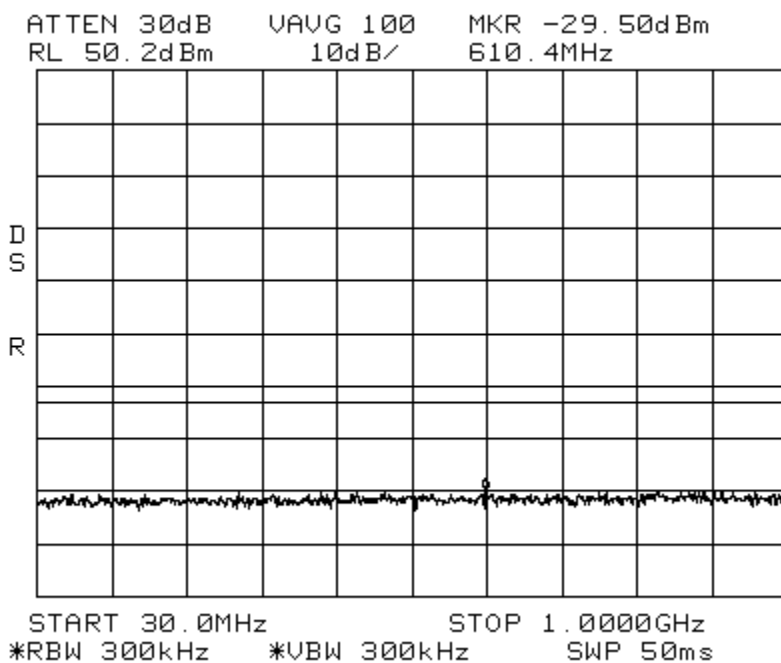

Conducted Emissions      LTE 5 MHz Channel Bandwidth      PCS 20W  
Span: 1 GHz to 5 GHz      RBW/VBW: 1 MHz

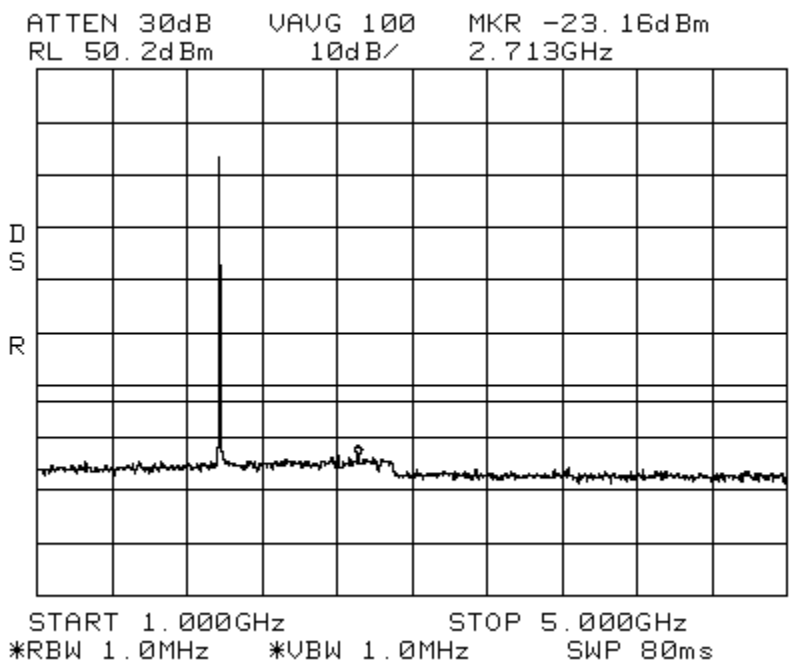

Conducted Emissions      LTE 5 MHz Channel Bandwidth      PCS 20W  
Span: 5 GHz to 20 GHz      RBW/VBW: 1 MHz

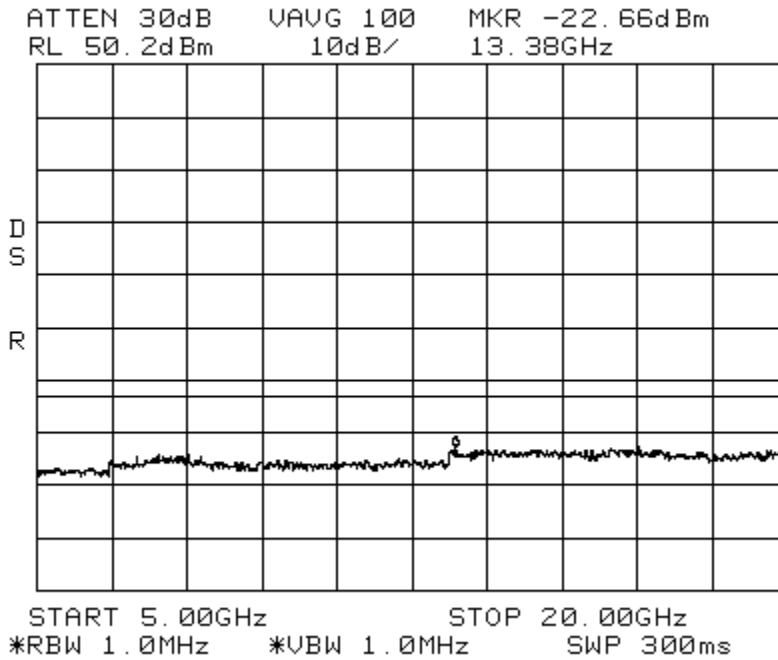

Conducted Emissions      LTE 10 MHz Channel Bandwidth      PCS 20W  
Center: 1962.5 MHz      Span: 20MHz      RBW/VBW: 100 kHz

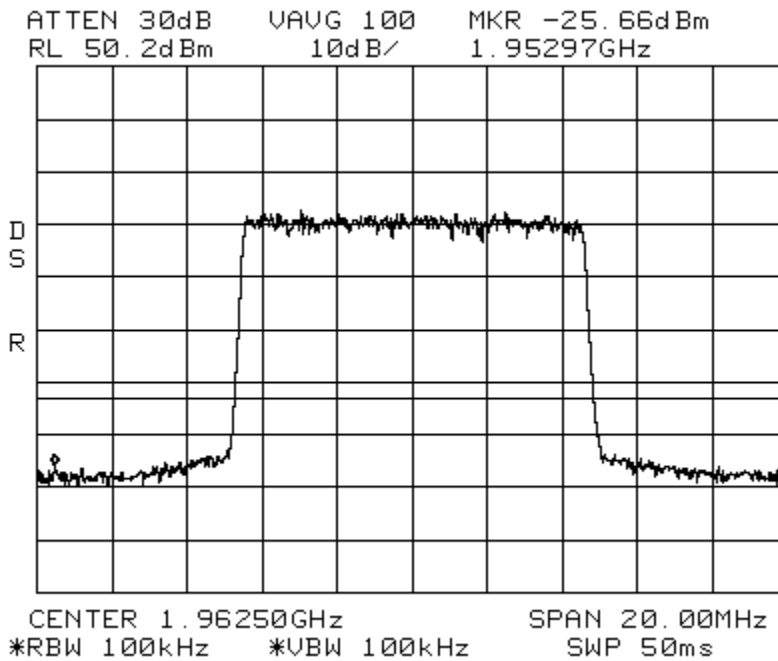

Conducted Emissions

LTE 10 MHz Channel Bandwidth

PCS 20W

Span: 30 MHz to 1 GHz

RBW/VBW: 300 kHz

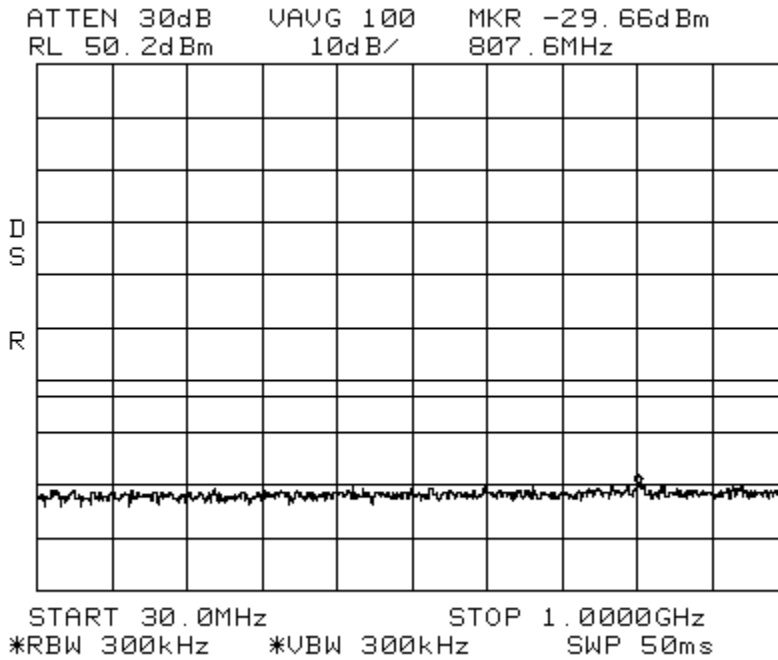

Conducted Emissions

LTE 10 MHz Channel Bandwidth

PCS 20W

Span: 1 GHz to 5 GHz

RBW/VBW: 1 MHz

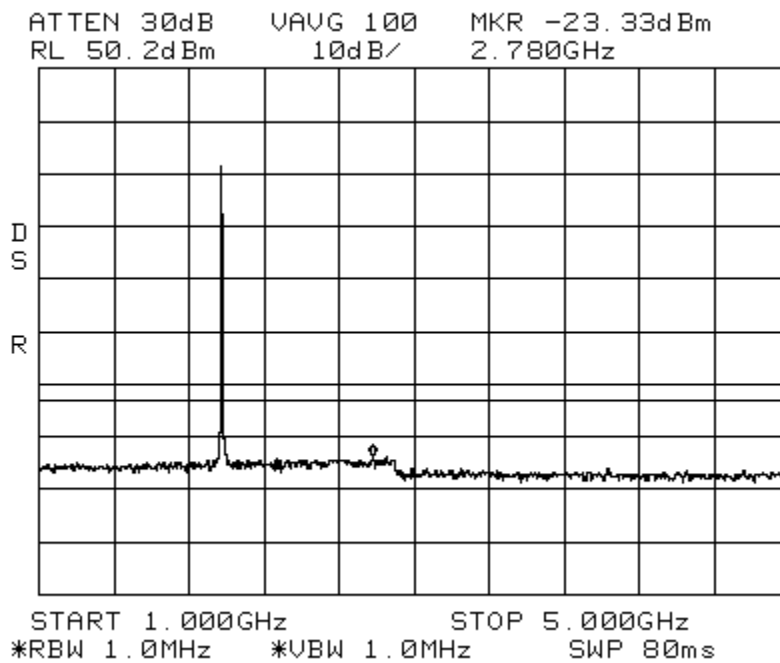

Conducted Emissions      LTE 10 MHz Channel Bandwidth      PCS 20W  
Span: 5 GHz to 20 GHz      RBW/VBW: 1 MHz

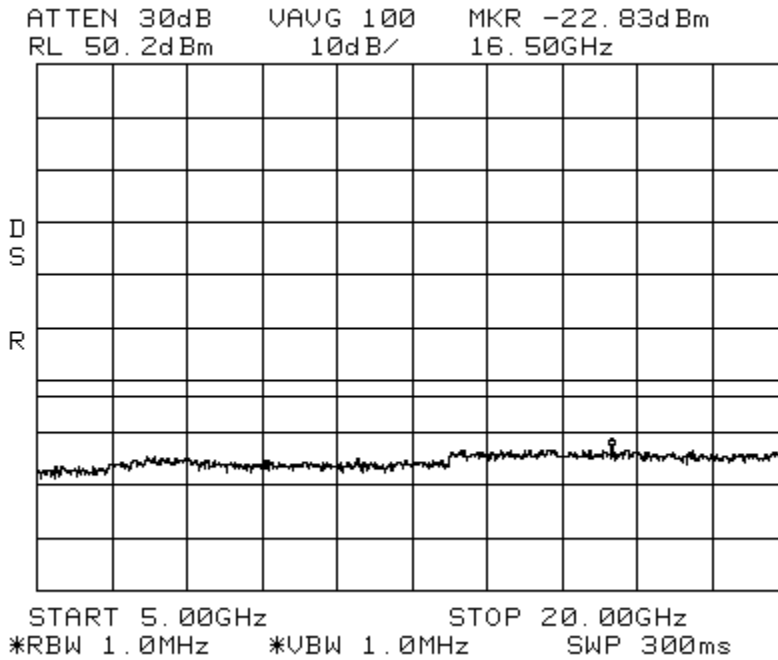

Conducted Emissions      LTE 15 MHz Channel Bandwidth      PCS 20W  
Center: 1962.5 MHz      Span: 30 MHz      RBW/VBW: 100 kHz

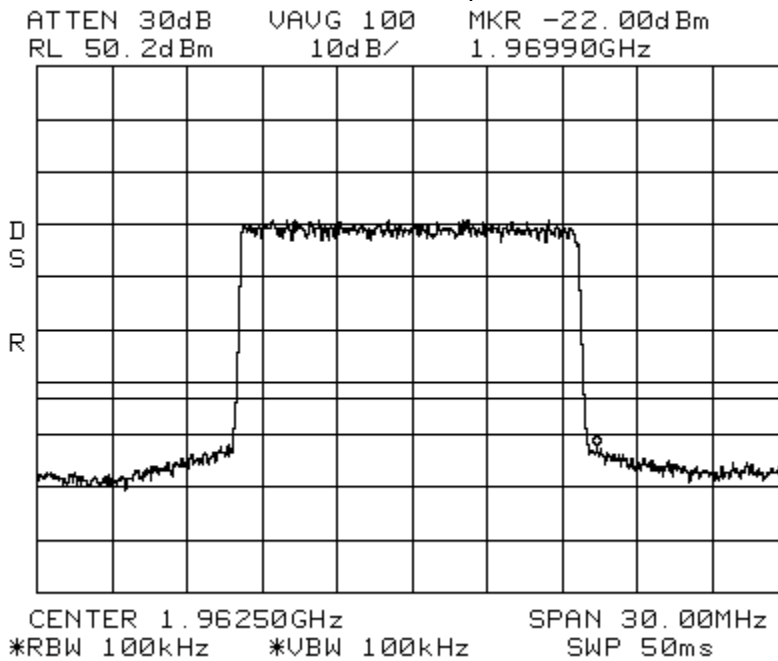

Conducted Emissions

LTE 15 MHz Channel Bandwidth

PCS 20W

Span: 30 MHz to 1 GHz

RBW/VBW: 300 kHz

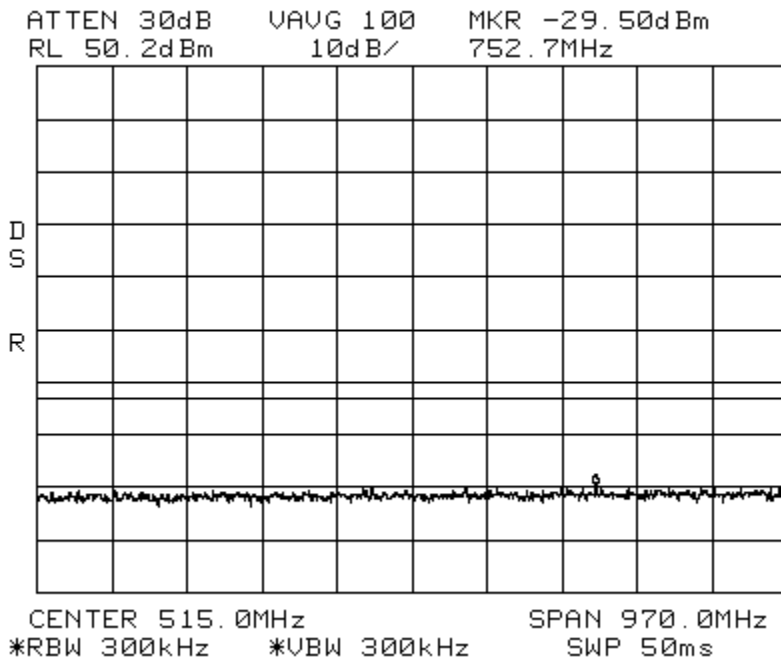

Conducted Emissions

LTE 15 MHz Channel Bandwidth

PCS 20W

Span: 1 GHz to 5 GHz

RBW/VBW: 1 MHz

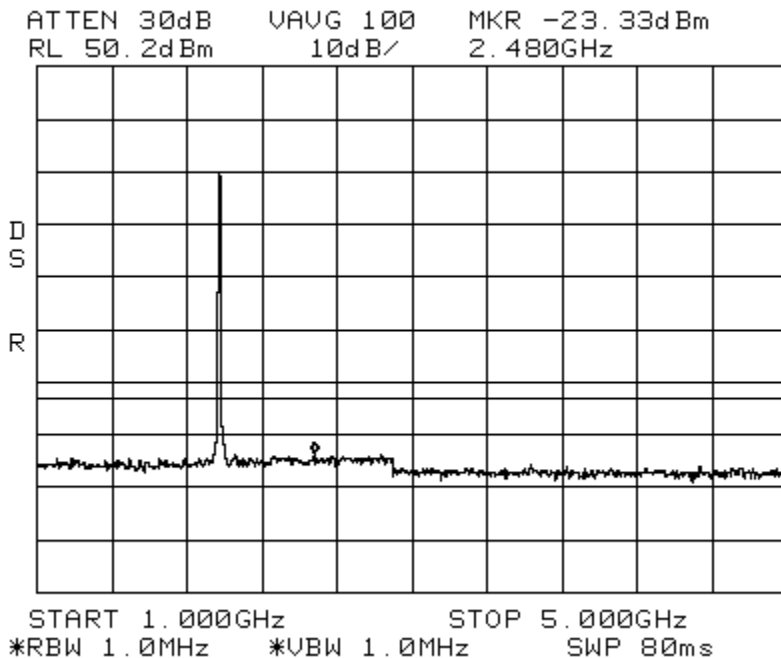

Conducted Emissions

LTE 15 MHz Channel Bandwidth

PCS 20W

Span: 5 GHz to 20 GHz

RBW/VBW: 1 MHz

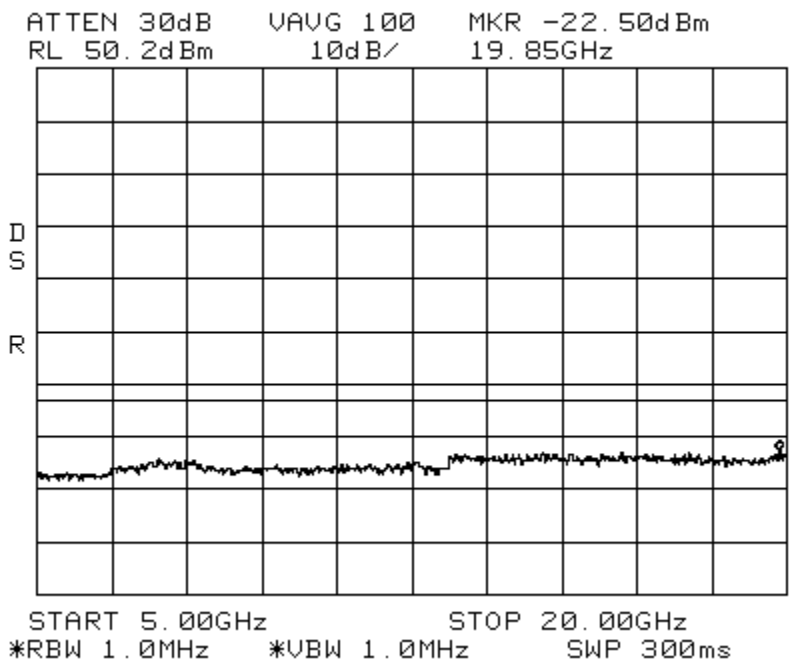

Conducted Emissions  
Center: 1962.5 MHz

WCDMA  
Span: 10 MHz

PCS 20W  
RBW/VBW: 100 kHz

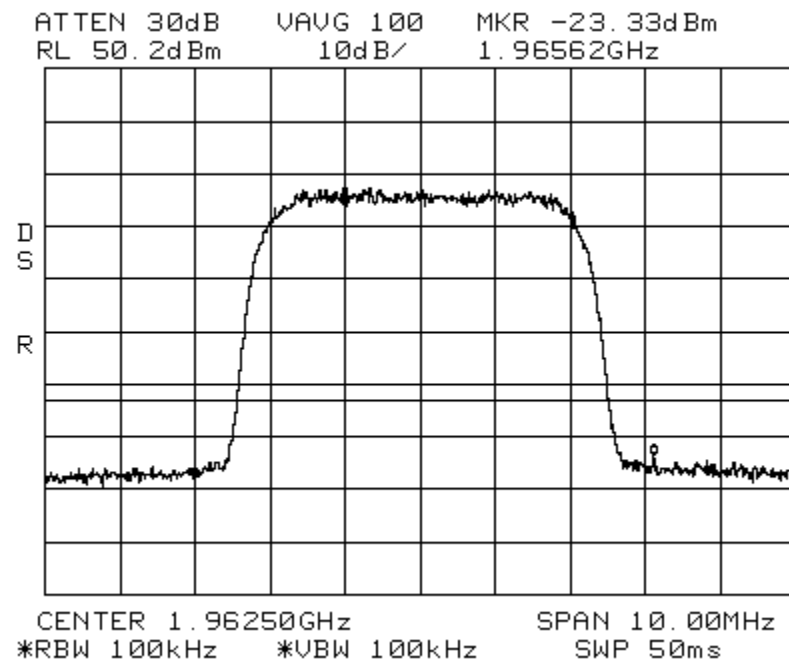



Conducted Emissions  
Span: 30 MHz to 1 GHz

WCDMA  
PCS 20W  
RBW/VBW: 300 kHz

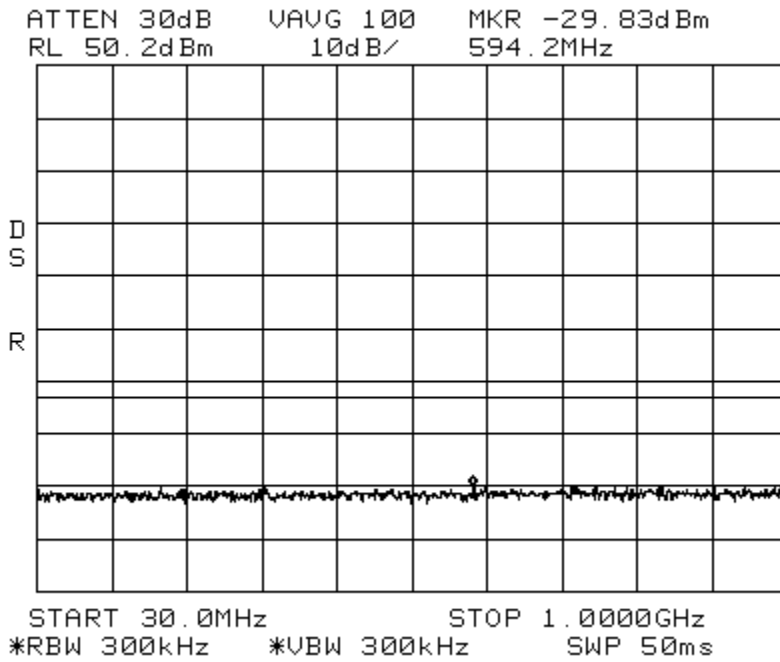

Conducted Emissions  
Span: 1 GHz to 5 GHz

WCDMA  
PCS 20W  
RBW/VBW: 1 MHz

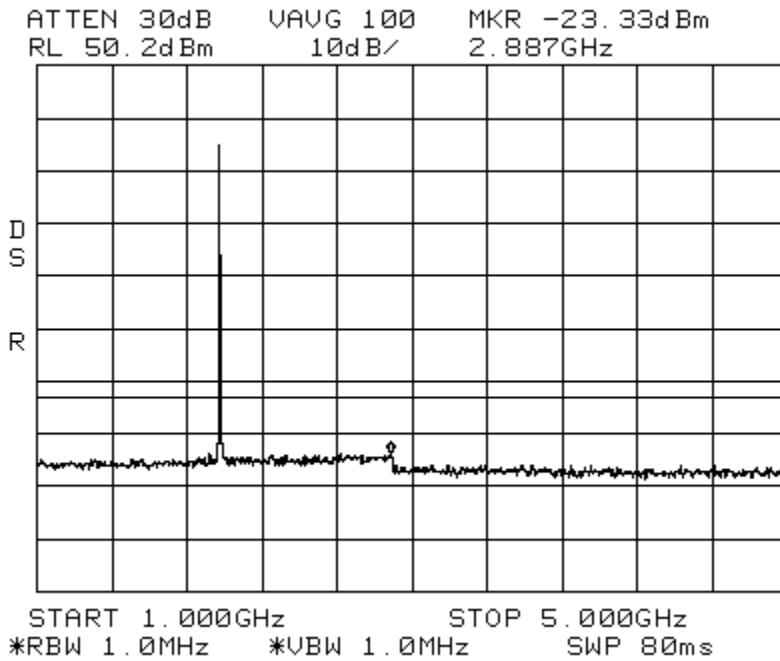

Conducted Emissions  
Span: 5 GHz to 20 GHz

WCDMA  
PCS 20W  
RBW/VBW: 1 MHz

ATTEN 30dB VAUG 100 MKR -22.66dBm  
RL 50.2dBm 10dB/ 13.78GHz

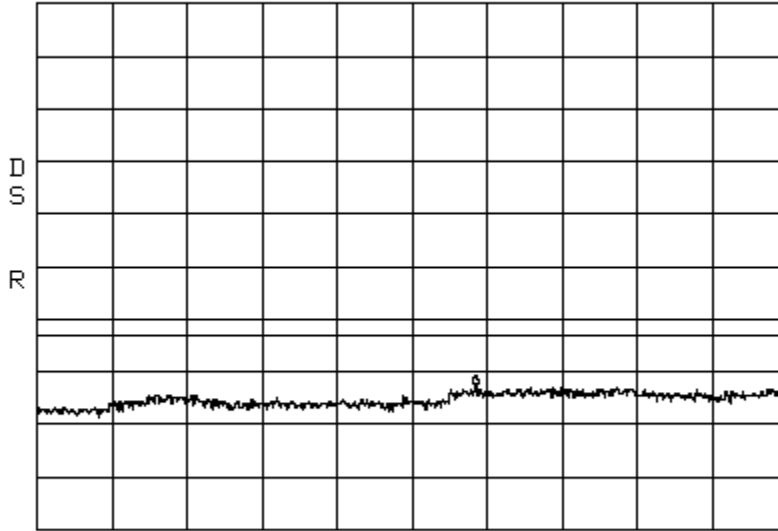

START 5.00GHz STOP 20.00GHz  
\*RBW 1.0MHz \*VBW 1.0MHz SWP 300ms

Intermodulation  
Center: 881.5 MHz

CDMA\_Low  
Span: 35 MHz

CELL 20W  
RBW/VBW: 100 kHz

ATTEN 30dB VAUG 100 MKR -23.33dBm  
RL 50.2dBm 10dB/ 876.31MHz

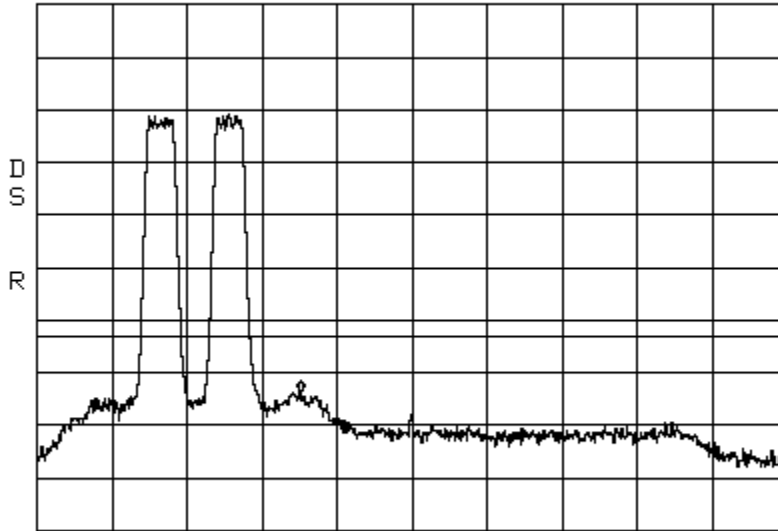

CENTER 881.50MHz SPAN 35.00MHz  
\*RBW 100kHz \*VBW 100kHz SWP 50ms

Intermodulation  
Span: 30 MHz to 1 GHz

CDMA\_Low  
CELL 20W  
RBW/VBW: 300 kHz

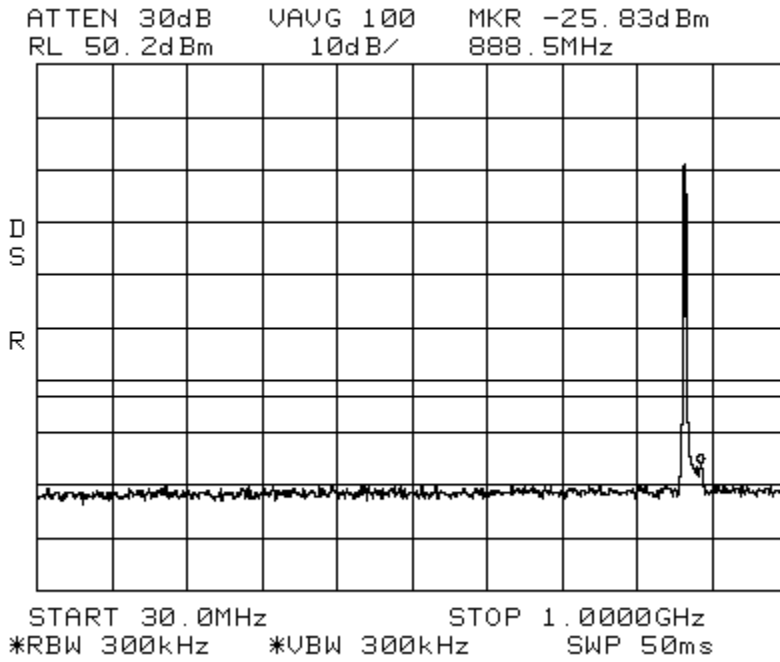

Intermodulation  
Span: 1 GHz to 10 GHz

CDMA\_Low  
CELL 20W  
RBW/VBW: 1 MHz

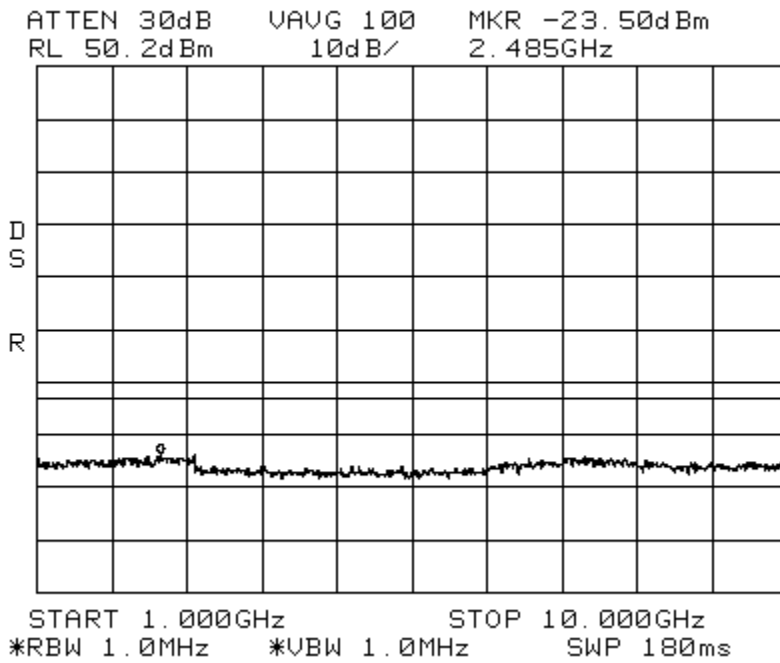

Intermodulation  
Center: 881.5 MHz

CDMA\_High  
Span: 35 MHz

CELL 20W  
RBW/VBW: 100 kHz

ATTEN 30dB    VAUG 100    MKR -23.83dBm  
RL 50.2dBm    10dB/    887.39MHz



CENTER 881.50MHz    SPAN 35.00MHz  
\*RBW 100kHz    \*VBW 100kHz    SWP 50ms

Intermodulation  
Span: 30 MHz to 1 GHz

CDMA\_High  
RBW/VBW: 300 kHz

CELLULAR

ATTEN 30dB    VAUG 100    MKR -29.33dBm  
RL 50.2dBm    10dB/    920.8MHz

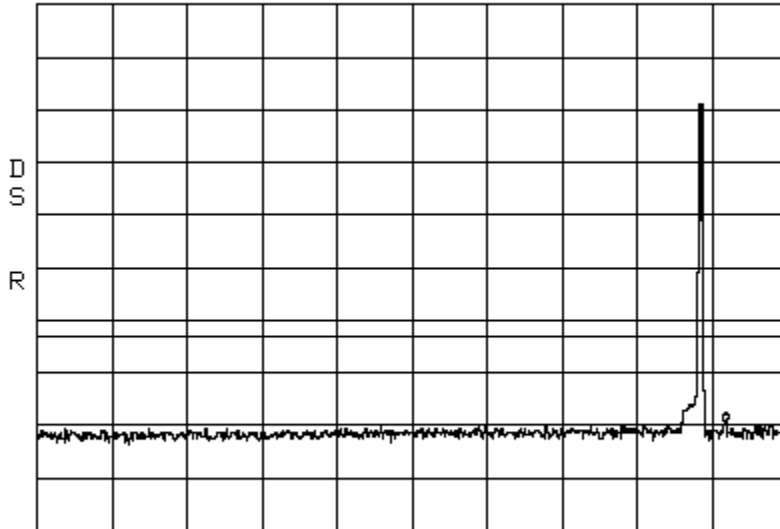

START 30.0MHz    STOP 1.0000GHz  
\*RBW 300kHz    \*VBW 300kHz    SWP 50ms

Intermodulation  
Span: 1 GHz to 10 GHz

CDMA\_High

CELL 20W

RBW/VBW: 1 MHz

ATTEN 30dB    VAUG 100    MKR -23.33dBm  
RL 50.2dBm    10dB/    7.840GHz

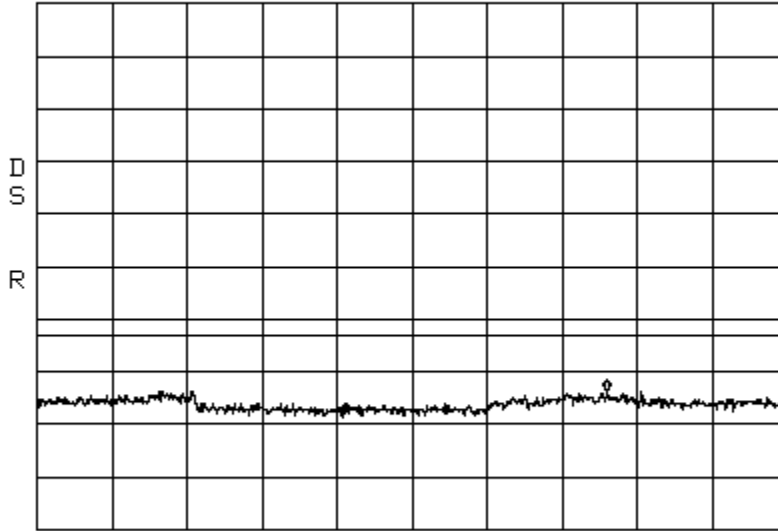

START 1.000GHz    STOP 10.000GHz  
\*RBW 1.0MHz    \*VBW 1.0MHz    SWP 180ms

Intermodulation  
Center: 881.5 MHz

CDMA\_Apart  
Span: 75 MHz

CELL 20W  
RBW/VBW: 100 kHz

ATTEN 30dB    VAUG 100    MKR -27.83dBm  
RL 50.2dBm    10dB/    881.38MHz

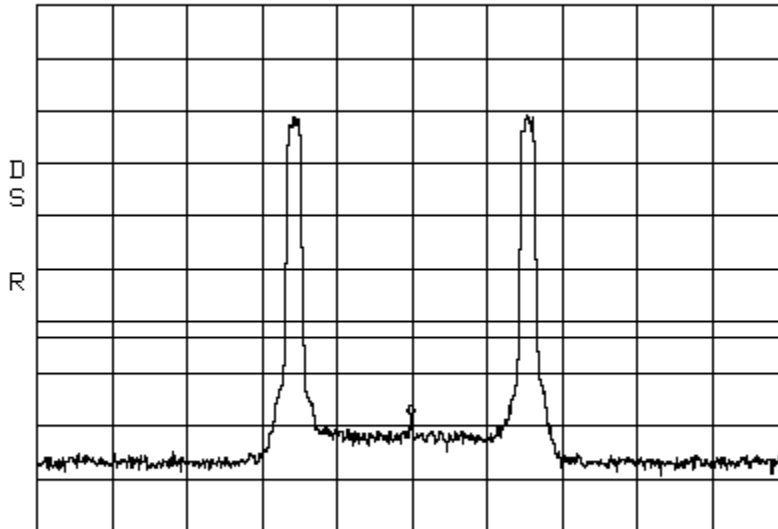

CENTER 881.50MHz    SPAN 75.00MHz  
\*RBW 100kHz    \*VBW 100kHz    SWP 50ms

Intermodulation

CDMA\_Apart

CELL 20W

Span: 30 MHz to 1 GHz

RBW/VBW: 300 kHz

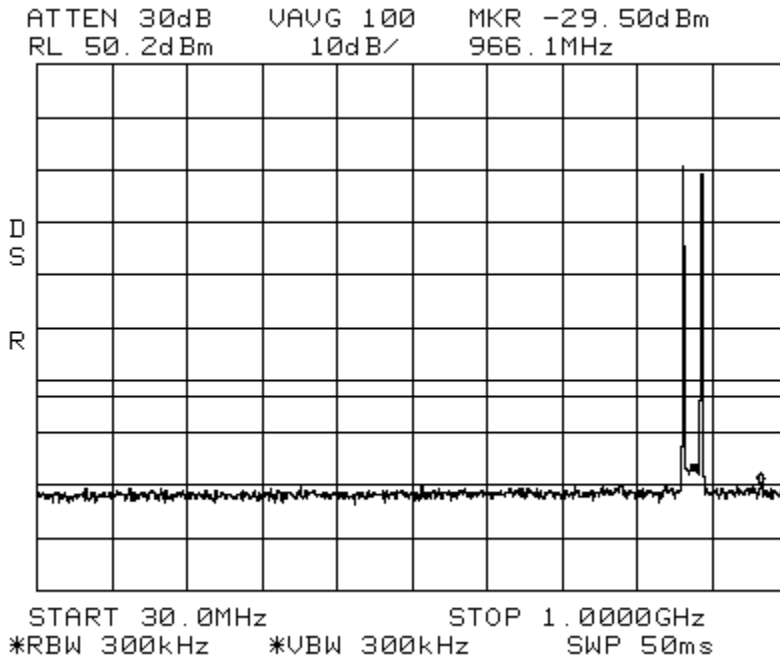

Intermodulation

CDMA\_Apart

CELL 20W

Span: 1 GHz to 10 GHz

RBW/VBW: 1 MHz

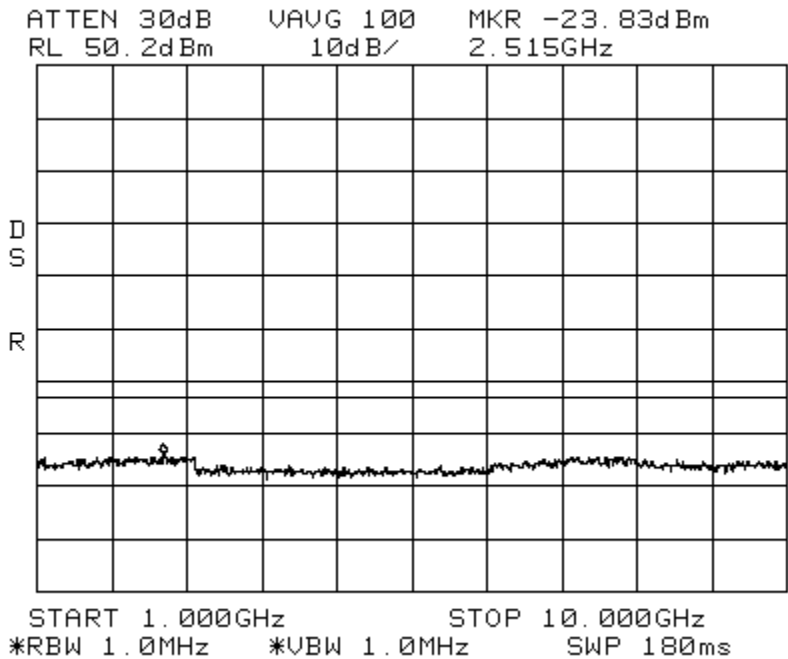

Intermodulation  
Center: 881.5 MHz

EDGE\_Low  
Span: 35 MHz

CELL 20W  
RBW/VBW: 100 kHz

ATTEN 30dB    VAUG 100    MKR -23.16dBm  
RL 50.2dBm    10dB/    872.75MHz

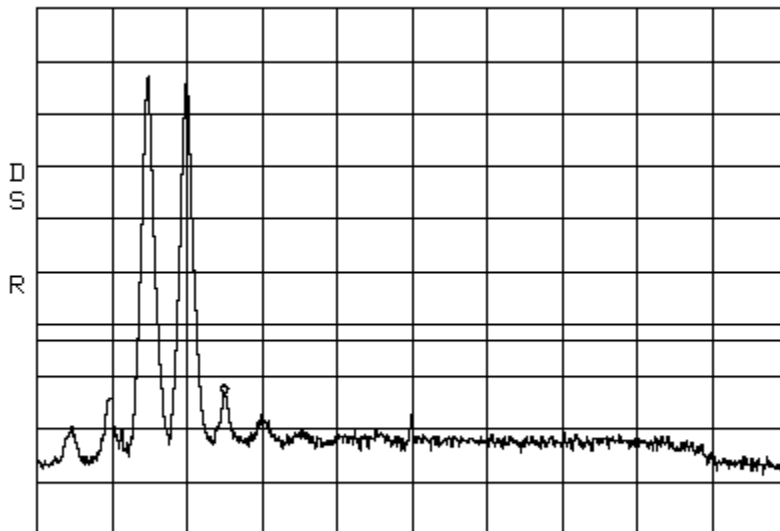

CENTER 881.50MHz    SPAN 35.00MHz  
\*RBW 100kHz    \*VBW 100kHz    SWP 50ms

Intermodulation  
Span: 30 MHz to 1 GHz

EDGE\_Low  
RBW/VBW: 300 kHz

ATTEN 30dB    VAUG 100    MKR -26.16dBm  
RL 50.2dBm    10dB/    880.4MHz

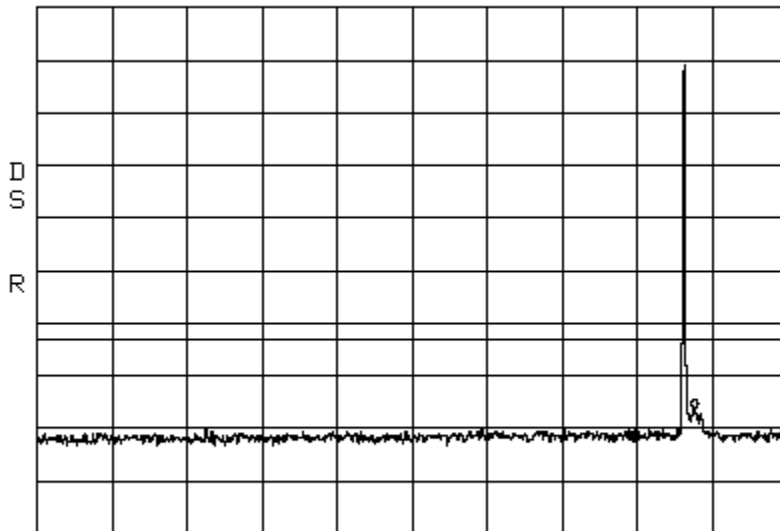

START 30.0MHz    STOP 1.0000GHz  
\*RBW 300kHz    \*VBW 300kHz    SWP 50ms

Intermodulation  
Span: 1 GHz to 10 GHz

EDGE\_Low

CELL 20W

RBW/VBW: 1 MHz

ATTEN 30dB    VAUG 100    MKR -23.66dBm  
RL 50.2dBm    10dB/    2.680GHz

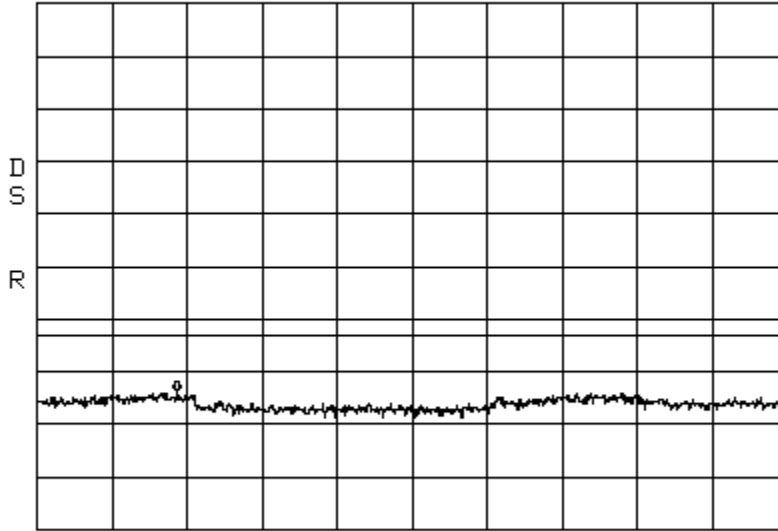

START 1.000GHz    STOP 10.000GHz  
\*RBW 1.0MHz    \*VBW 1.0MHz    SWP 180ms

Intermodulation  
Center: 881.5 MHz

EDGE\_High  
Span: 35 MHz

CELL 20W  
RBW/VBW: 100 kHz

ATTEN 30dB    VAUG 100    MKR -21.83dBm  
RL 50.2dBm    10dB/    890.19MHz

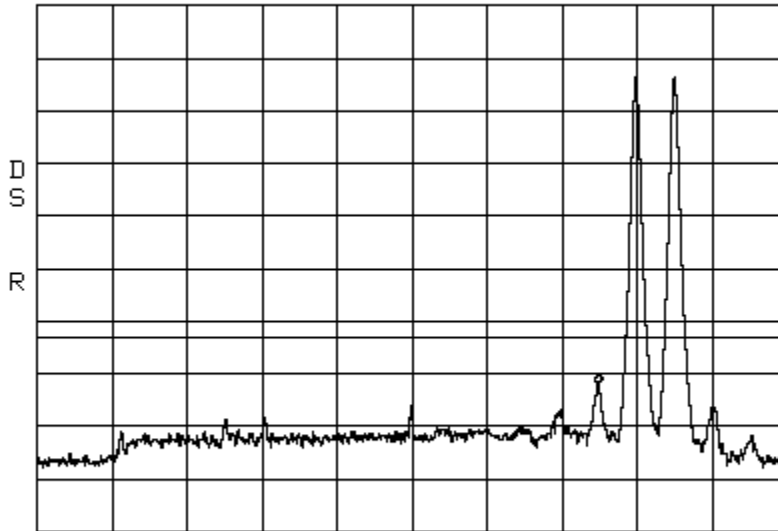

CENTER 881.50MHz    SPAN 35.00MHz  
\*RBW 100kHz    \*VBW 100kHz    SWP 50ms



Intermodulation  
Span: 30 MHz to 1 GHz

EDGE\_High  
CELL 20W  
RBW/VBW: 300 kHz

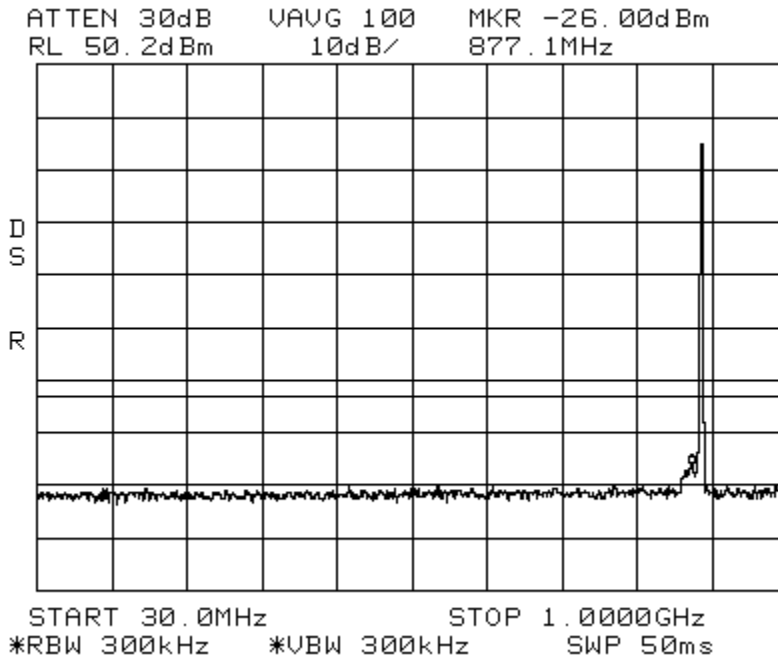

Intermodulation  
Span: 1 GHz to 10 GHz

EDGE\_High  
CELL 20W  
RBW/VBW: 1 MHz

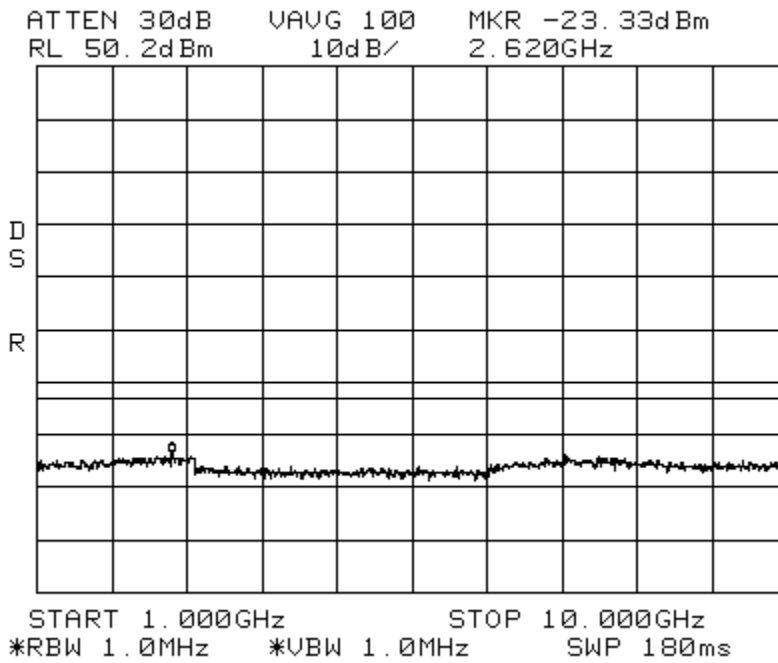

Intermodulation                      EDGE\_Apart                      CELL 20W  
 Center: 881.5 MHz                      Span: 75 MHz                      RBW/VBW: 100 kHz  
 ATTN 30dB      VAUG 100      MKR -27.50dBm  
 RL 50.2dBm      10dB/      872.75MHz

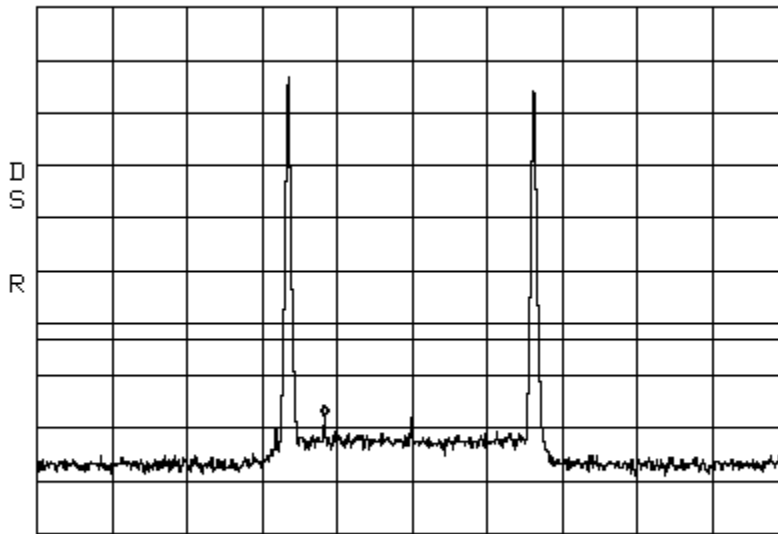

CENTER 881.50MHz                      SPAN 75.00MHz  
 \*RBW 100kHz      \*VBW 100kHz      SWP 50ms

Intermodulation                      EDGE\_Apart                      CELL 20W  
 Span: 30 MHz to 1 GHz                      RBW/VBW: 300 kHz

ATTN 30dB      VAUG 100      MKR -29.66dBm  
 RL 50.2dBm      10dB/      836.7MHz

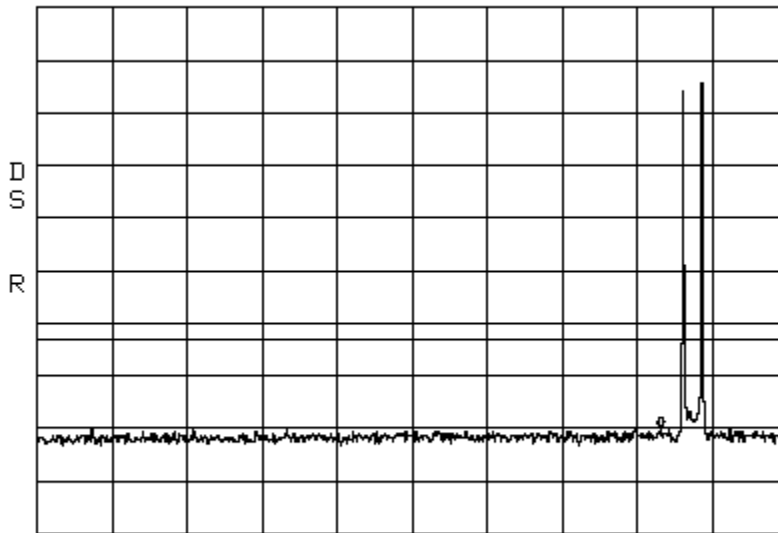

START 30.0MHz                      STOP 1.0000GHz  
 \*RBW 300kHz      \*VBW 300kHz      SWP 50ms

Intermodulation  
Span: 1 GHz to 10 GHz

EDGE\_Apart

CELL 20W

RBW/VBW: 1 MHz

ATTEN 30dB VAUG 100 MKR -23.66dBm  
RL 50.2dBm 10dB/ 2.890GHz

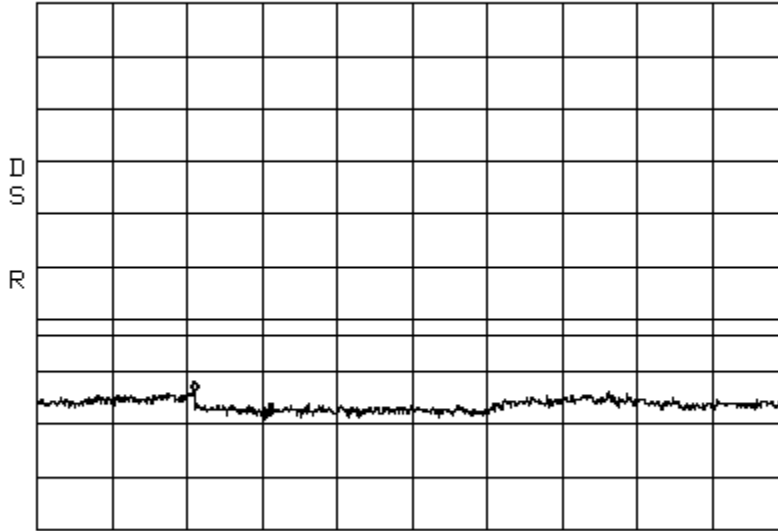

START 1.000GHz STOP 10.000GHz  
\*RBW 1.0MHz \*VBW 1.0MHz SWP 180ms

Intermodulation  
Center: 881.5 MHz

GSM\_Low  
Span: 35 MHz

CELL 20W  
RBW/VBW: 100 kHz

ATTEN 30dB VAUG 100 MKR -23.50dBm  
RL 50.2dBm 10dB/ 867.38MHz

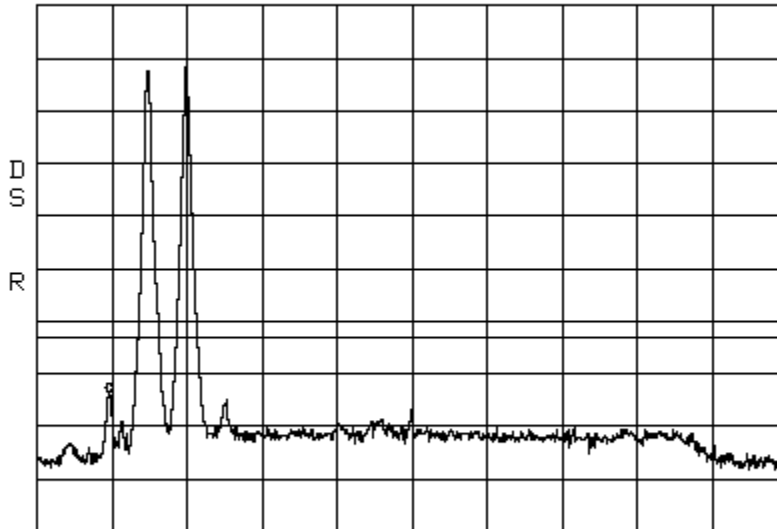

CENTER 881.50MHz SPAN 35.00MHz  
\*RBW 100kHz \*VBW 100kHz SWP 50ms

Intermodulation  
Span: 30 MHz to 1 GHz

GSM\_Low

CELL 20W

RBW/VBW: 300 kHz

ATTEN 30dB    VAUG 100    MKR -30.16dBm  
RL 50.2dBm    10dB/    948.3MHz

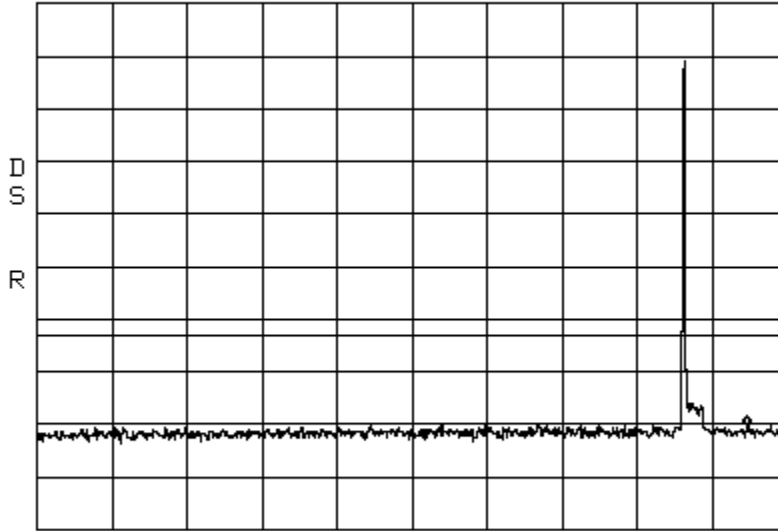

START 30.0MHz    STOP 1.0000GHz  
\*RBW 300kHz    \*VBW 300kHz    SWP 50ms

Intermodulation  
Span: 1 GHz to 10 GHz

GSM\_Low

CELL 20W

RBW/VBW: 1 MHz

ATTEN 30dB    VAUG 100    MKR -23.50dBm  
RL 50.2dBm    10dB/    2.890GHz

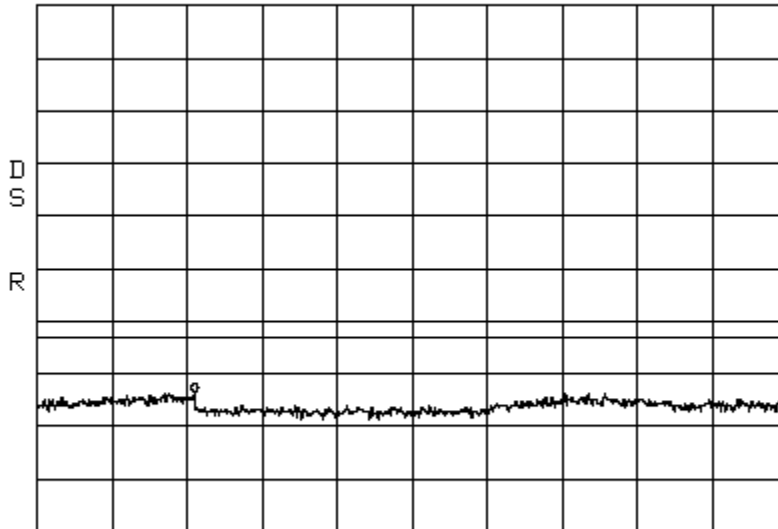

START 1.000GHz    STOP 10.000GHz  
\*RBW 1.0MHz    \*VBW 1.0MHz    SWP 180ms

Intermodulation  
Center: 881.5 MHz

GSM\_High  
Span: 35 MHz

CELL 20W  
RBW/VBW: 100 kHz

ATTEN 30dB    VAUG 100    MKR -26.16dBm  
RL 50.2dBm    10dB/    890.25MHz

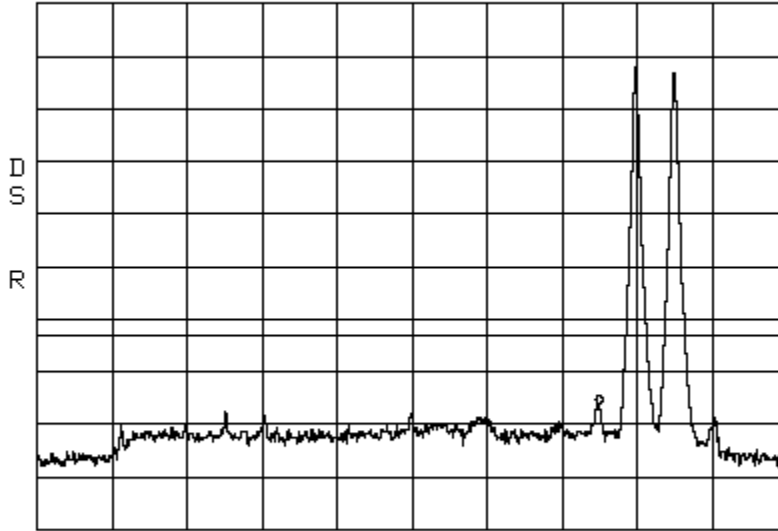

CENTER 881.50MHz    SPAN 35.00MHz  
\*RBW 100kHz    \*VBW 100kHz    SWP 50ms

Intermodulation  
Span: 30 MHz to 1 GHz

GSM\_High

CELL 20W

RBW/VBW: 300 kHz

ATTEN 30dB    VAUG 100    MKR -29.66dBm  
RL 50.2dBm    10dB/    626.6MHz

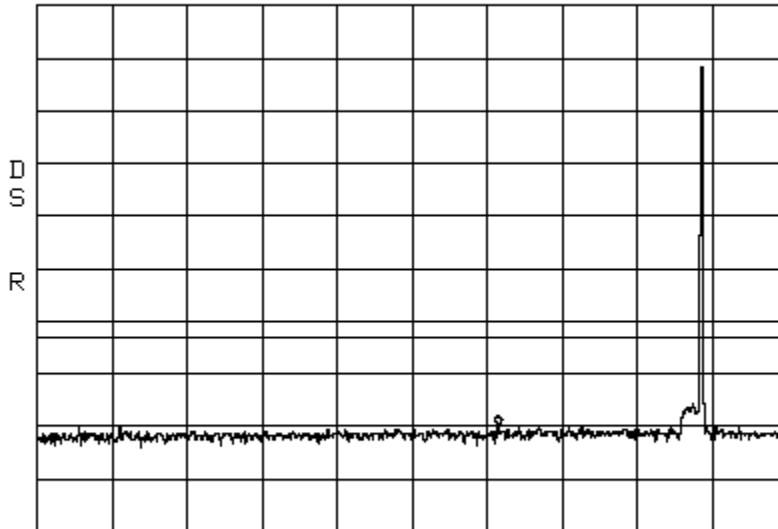

START 30.0MHz    STOP 1.0000GHz  
\*RBW 300kHz    \*VBW 300kHz    SWP 50ms

Intermodulation  
Span: 1 GHz to 10 GHz

GSM\_High

CELL 20W

RBW/VBW: 1 MHz

ATTEN 30dB    VAVG 100    MKR -23.33dBm  
RL 50.2dBm    10dB/    2.860GHz

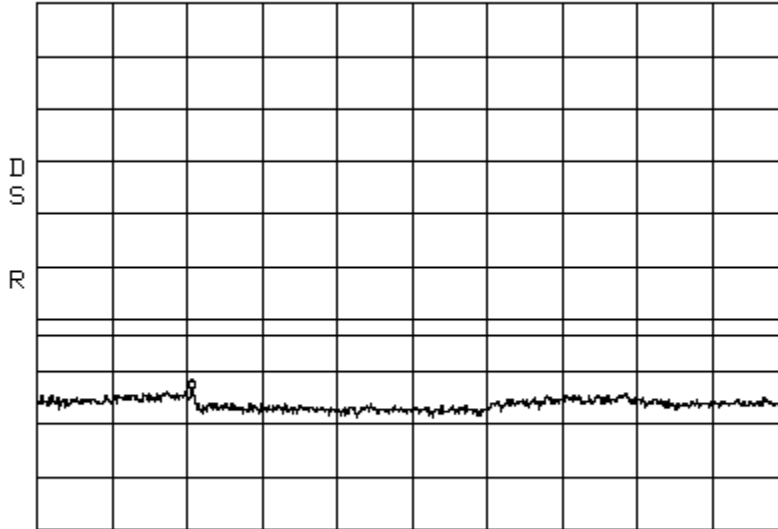

START 1.000GHz    STOP 10.000GHz  
\*RBW 1.0MHz    \*VBW 1.0MHz    SWP 180ms

Intermodulation  
Center: 881.5 MHz

GSM\_Apart  
Span: 75 MHz

CELL 20W  
RBW/VBW: 100 kHz

ATTEN 30dB    VAVG 100    MKR -27.83dBm  
RL 50.2dBm    10dB/    872.75MHz

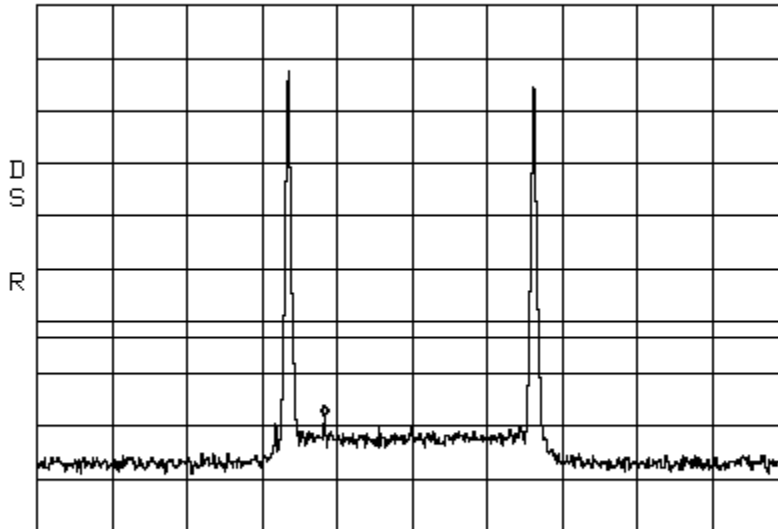

CENTER 881.50MHz    SPAN 75.00MHz  
\*RBW 100kHz    \*VBW 100kHz    SWP 50ms

Intermodulation  
Span: 30 MHz to 1 GHz

GSM\_Apart

CELL 20W

RBW/VBW: 300 kHz

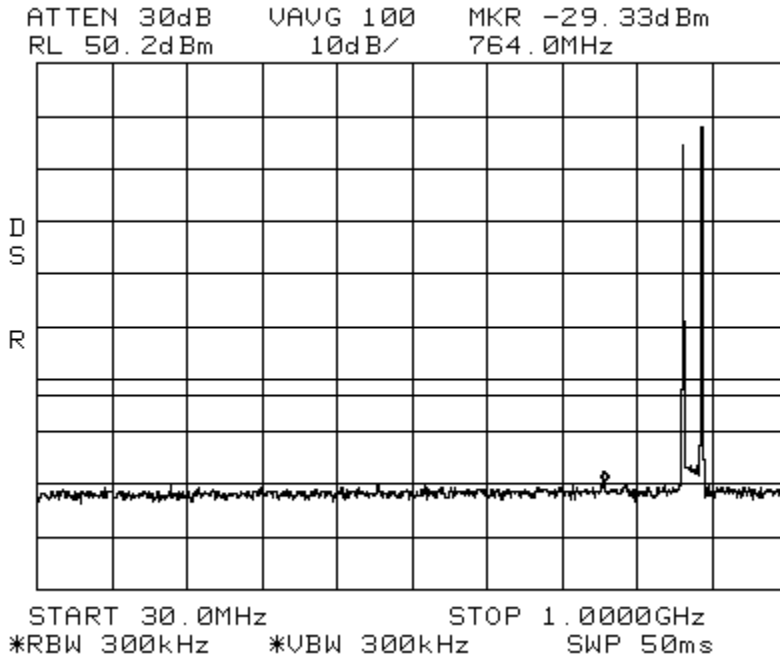

Intermodulation  
Span: 1 GHz to 10 GHz

GSM\_Apart

CELL 20W

RBW/VBW: 1 MHz

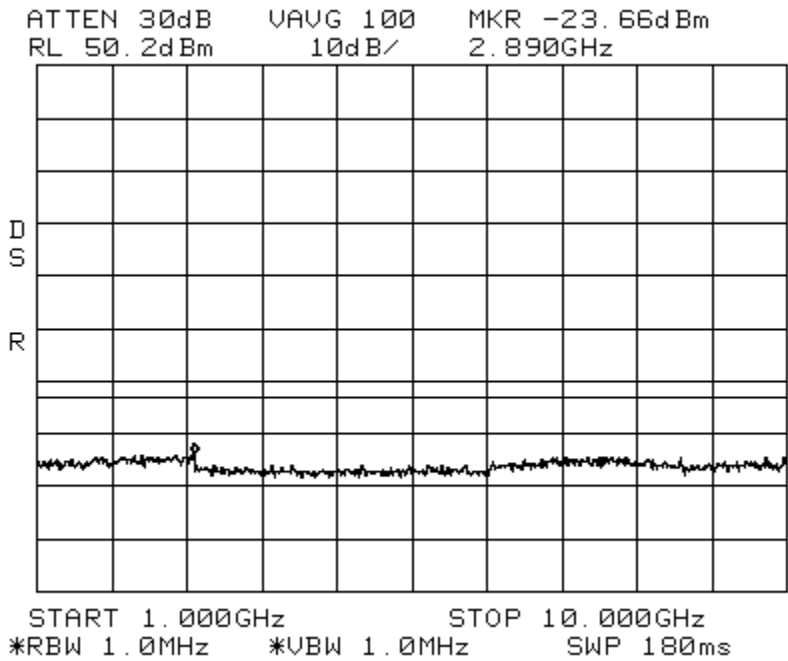

Intermodulation      LTE 3MHz Channel Bandwidth \_LowCELL 20W  
Center: 881.5 MHz      Span: 35 MHz      RBW/VBW: 100 kHz

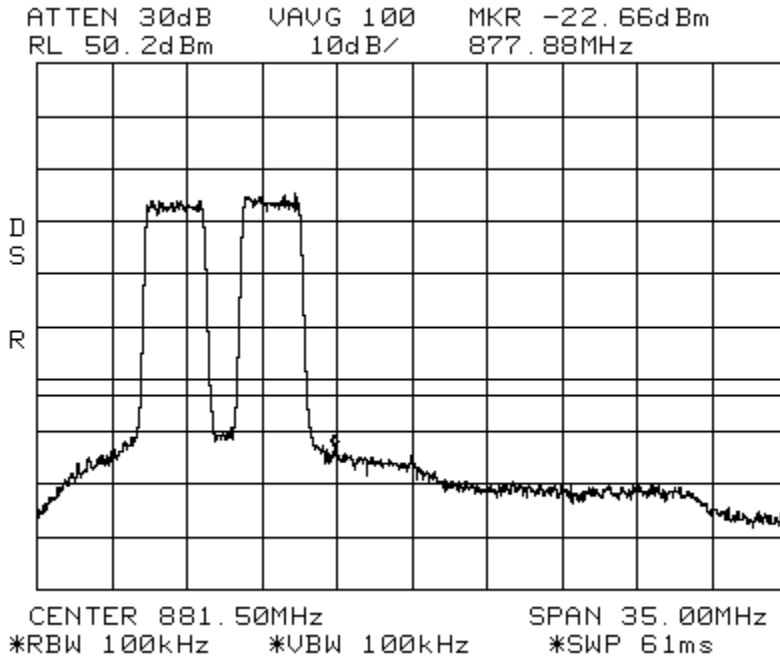

Intermodulation      LTE 3MHz Channel Bandwidth \_LowCELL 20W  
Span: 30 MHz to 1 GHz      RBW/VBW: 300 kHz

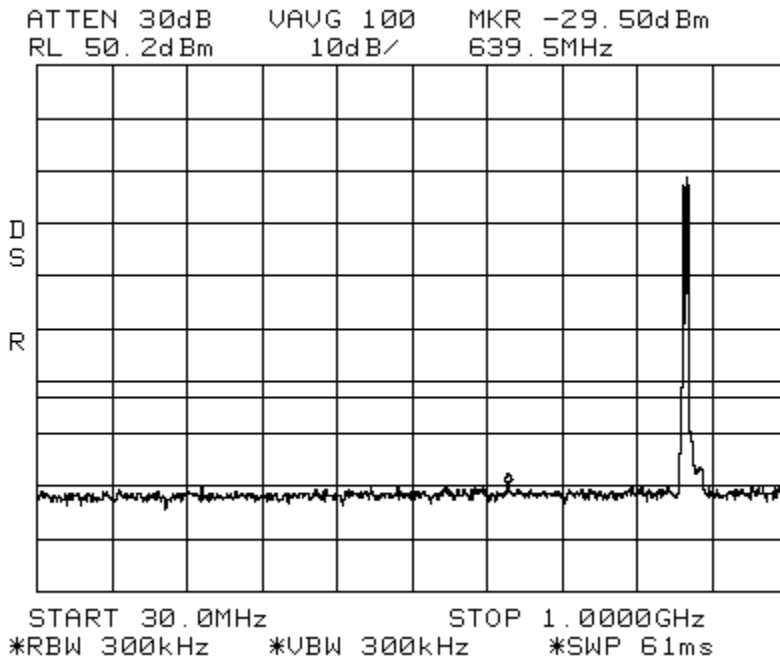



Intermodulation      LTE 3 MHz Channel Bandwidth \_Low      CELL 20W  
Span: 1 GHz to 10 GHz      RBW/VBW: 1 MHz

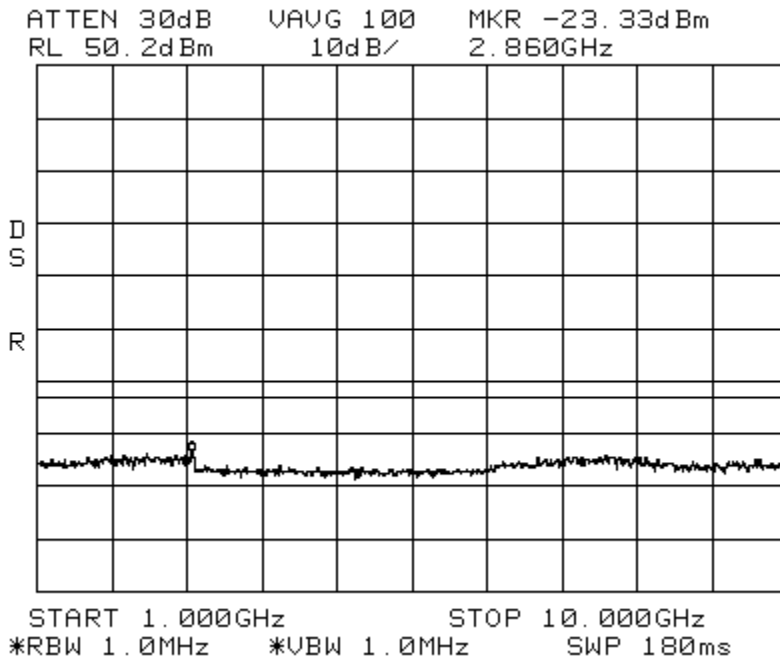

Intermodulation      LTE 3 MHz Channel Bandwidth \_High      CELL 20W  
Center: 881.5 MHz      Span: 35 MHz      RBW/VBW: 100 kHz

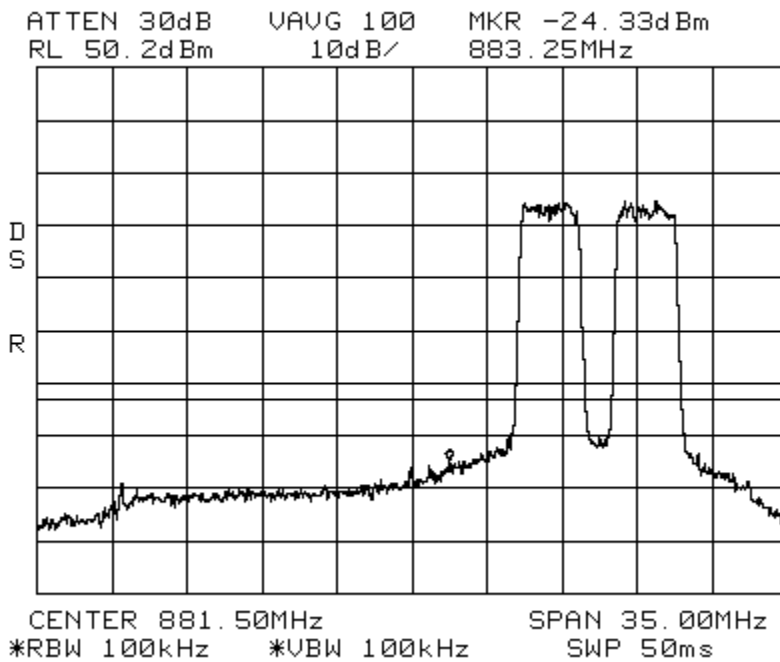

Intermodulation      LTE 3 MHz Channel Bandwidth\_High      CELL 20W  
Span: 30 MHz to 1 GHz      RBW/VBW: 300 kHz

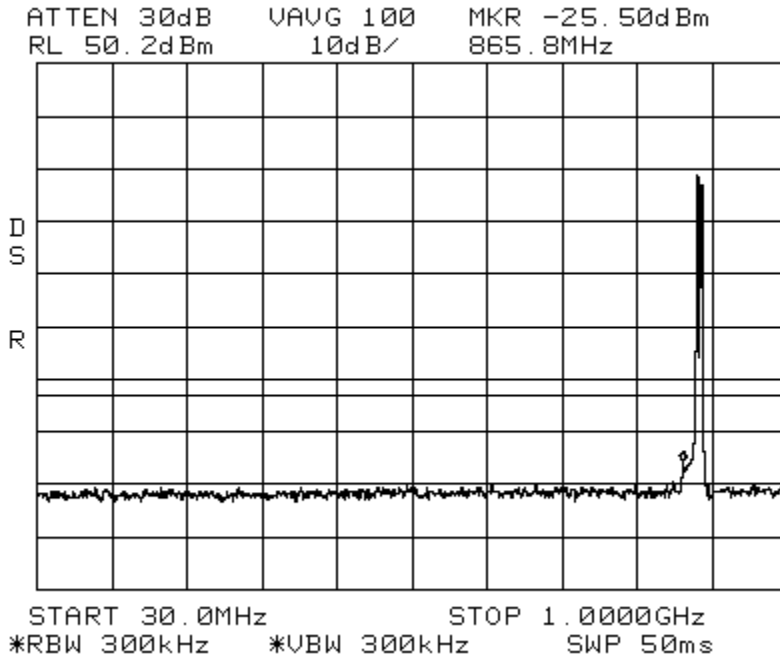

Intermodulation      LTE 3 MHz Channel Bandwidth\_High      CELL 20W  
Span: 1 GHz to 10 GHz      RBW/VBW: 1 MHz

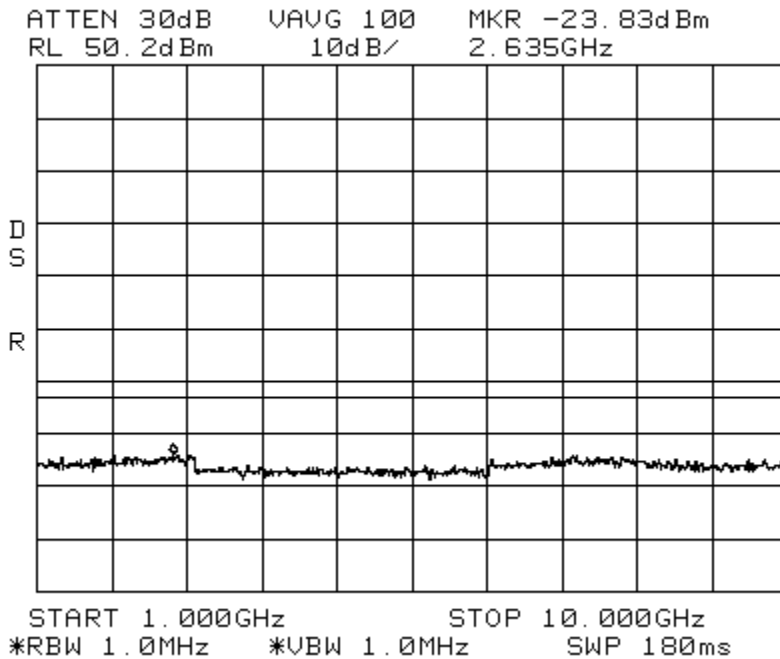

Intermodulation LTE 3 MHz Channel Bandwidth \_Apart CELL 20W  
Center: 881.5 MHz Span: 70 MHz RBW/VBW: 100 kHz

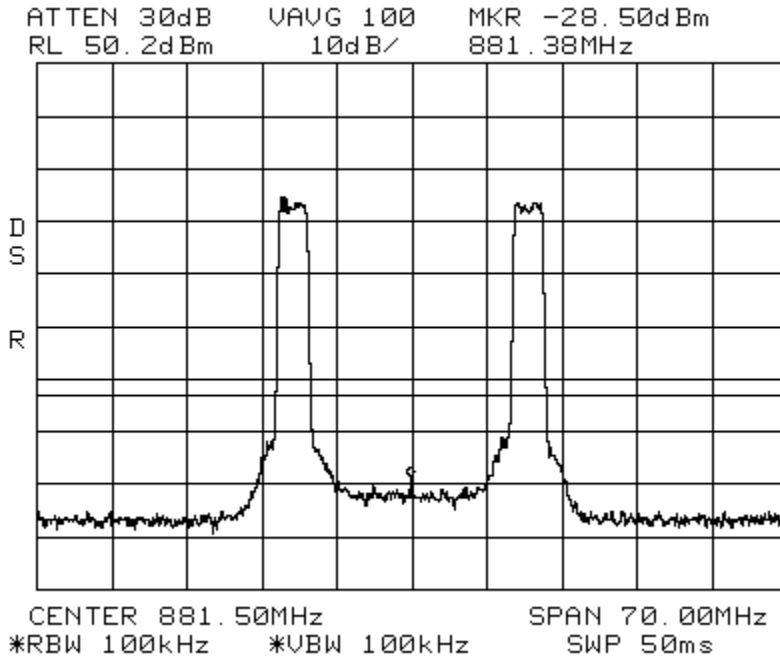

Intermodulation LTE 3 MHz Channel Bandwidth \_Apart CELL 20W  
Span: 30 MHz to 1 GHz RBW/VBW: 300 kHz

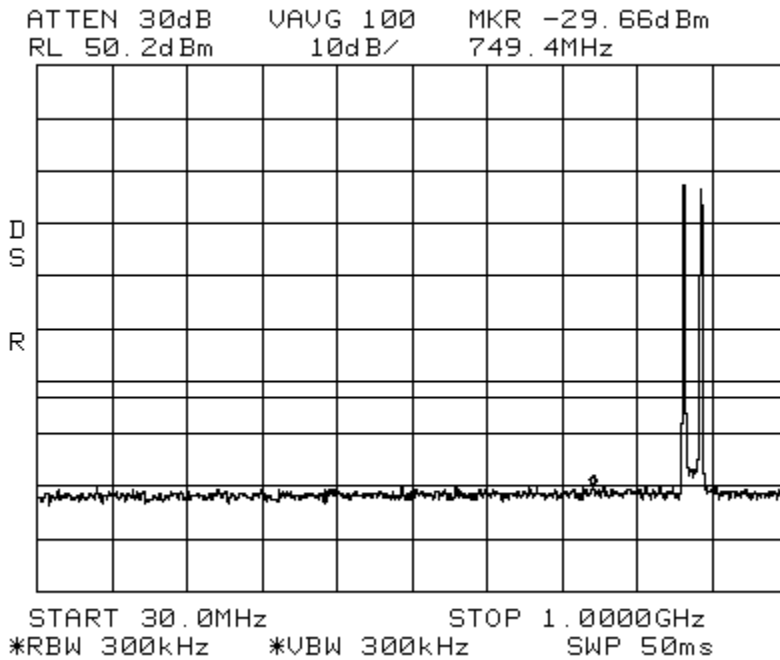

Intermodulation LTE 3 MHz Channel Bandwidth\_Apart CELL 20W  
Span: 1 GHz to 10 GHz RBW/VBW: 1 MHz

ATTEN 30dB VAUG 100 MKR -23.66dBm  
RL 50.2dBm 10dB/ 2.845GHz

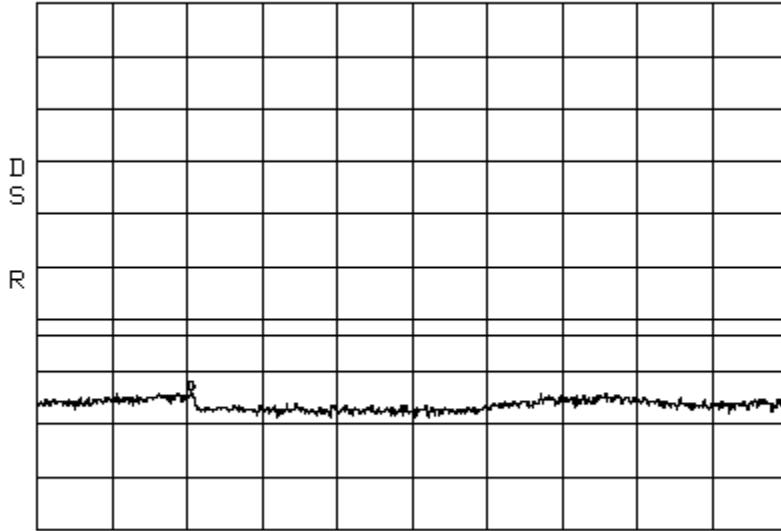

START 1.000GHz STOP 10.000GHz  
\*RBW 1.0MHz \*VBW 1.0MHz SWP 180ms

Intermodulation LTE 5 MHz Channel Bandwidth\_Low CELL 20W  
Center: 881.5 MHz Span: 35 MHz RBW/VBW: 100 kHz

ATTEN 30dB VAUG 100 MKR -23.66dBm  
RL 50.2dBm 10dB/ 881.50MHz

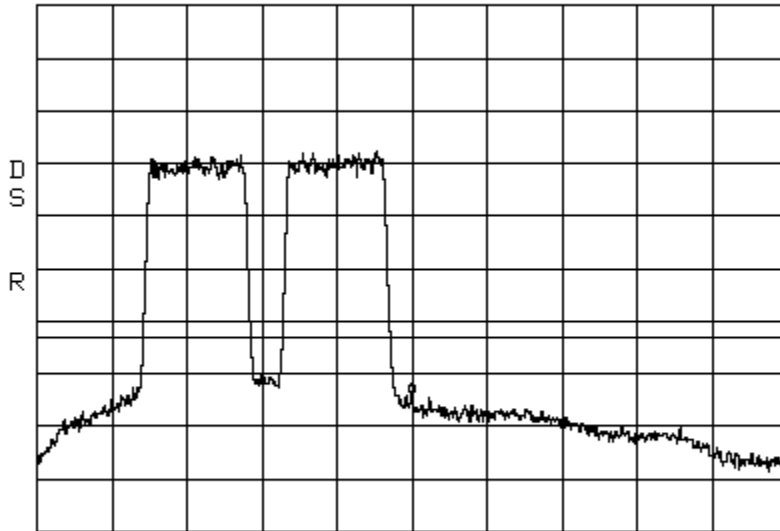

CENTER 881.50MHz SPAN 35.00MHz  
\*RBW 100kHz \*VBW 100kHz SWP 50ms

Intermodulation LTE 5 MHz Channel Bandwidth\_Low CELL 20W  
Span: 30 MHz to 1 GHz RBW/VBW: 300 kHz

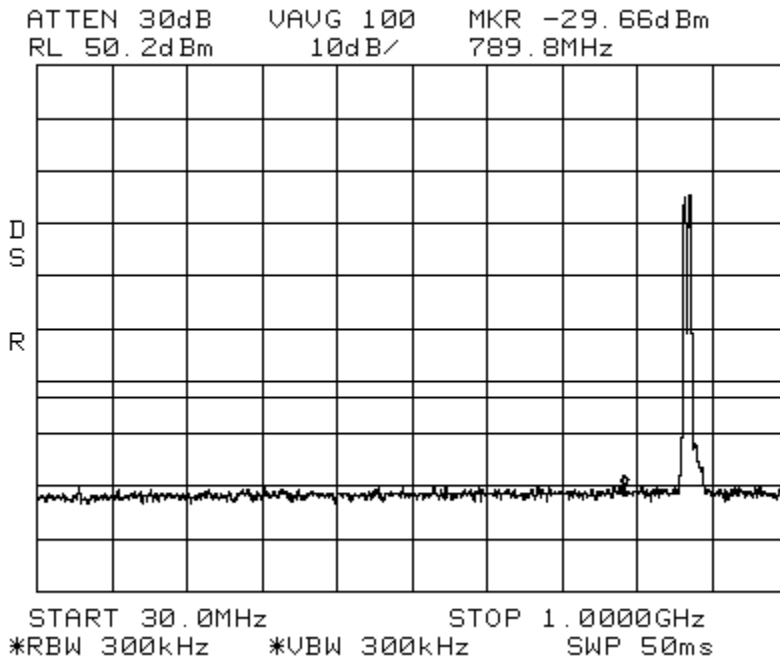

Intermodulation LTE 5 MHz Channel Bandwidth\_Low CELL 20W  
Span: 1 GHz to 10 GHz RBW/VBW: 1 MHz

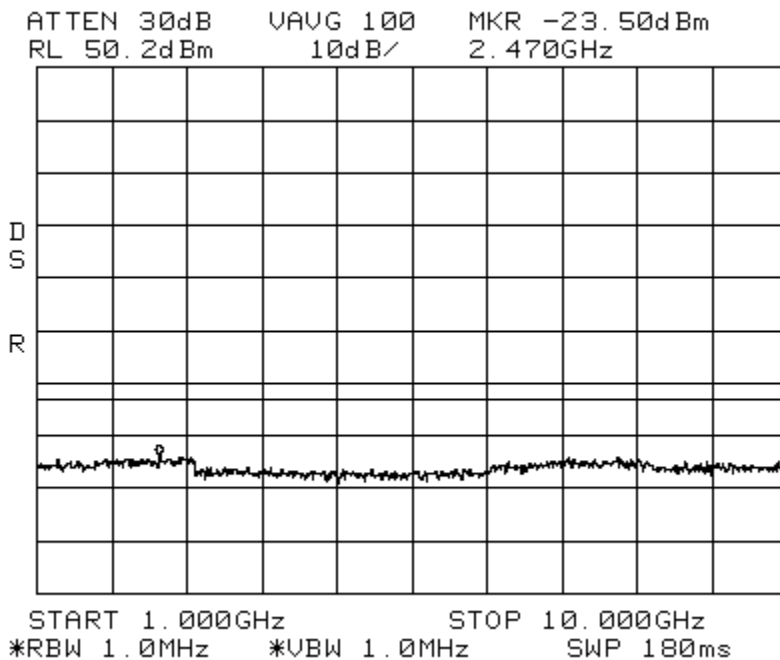

Intermodulation LTE 5 MHz Channel Bandwidth\_High CELL 20W  
Center: 881.5 MHz Span: 35 MHz RBW/VBW: 100 kHz

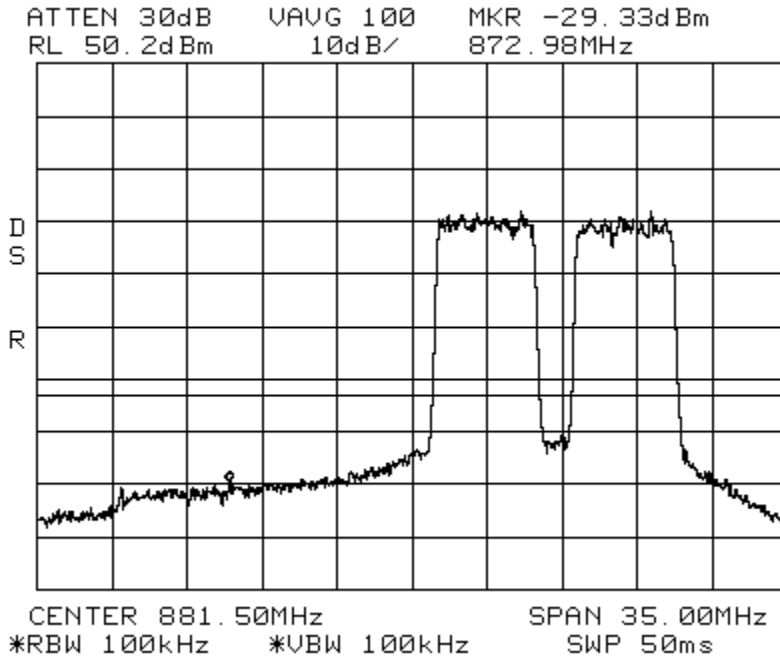

Intermodulation LTE 5 MHz Channel Bandwidth\_High CELL 20W  
Span: 30 MHz to 1 GHz RBW/VBW: 300 kHz

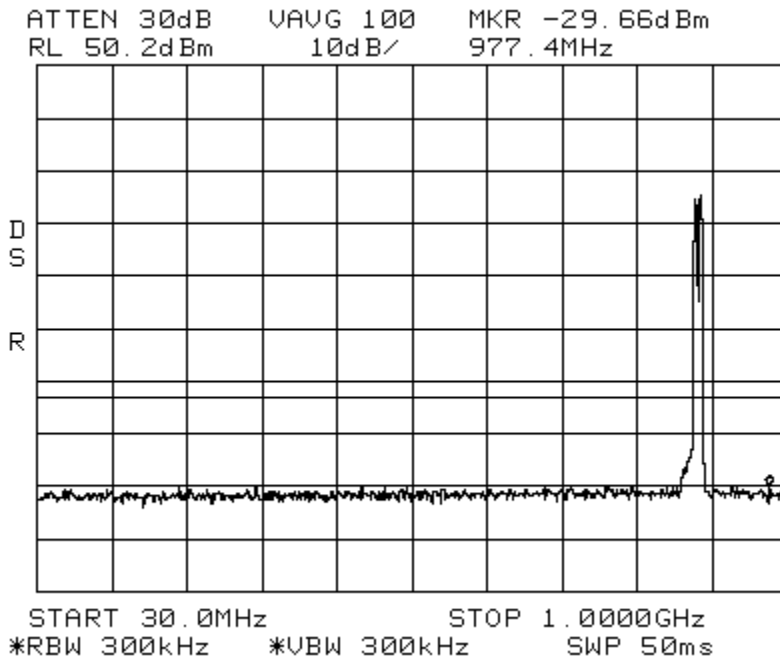

Intermodulation      LTE 5 MHz Channel Bandwidth\_High      CELL 20W  
Span: 1 GHz to 10 GHz      RBW/VBW: 1 MHz

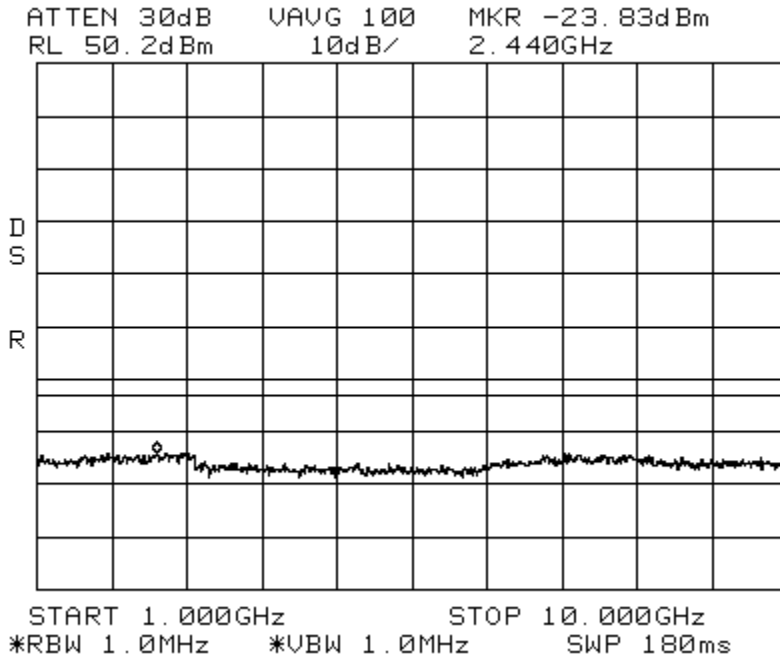

Intermodulation      LTE 5 MHz Channel Bandwidth\_Apart      CELL 20W  
Center: 881.5 MHz      Span: 70 MHz      RBW/VBW: 100 kHz

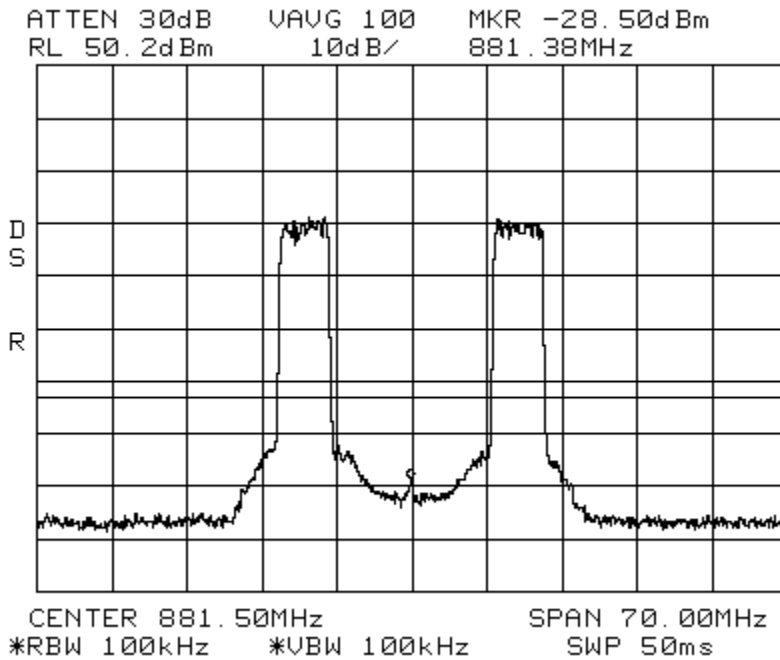

Intermodulation LTE 5 MHz Channel Bandwidth \_Apart CELL 20W  
Span: 30 MHz to 1 GHz RBW/VBW: 300 kHz

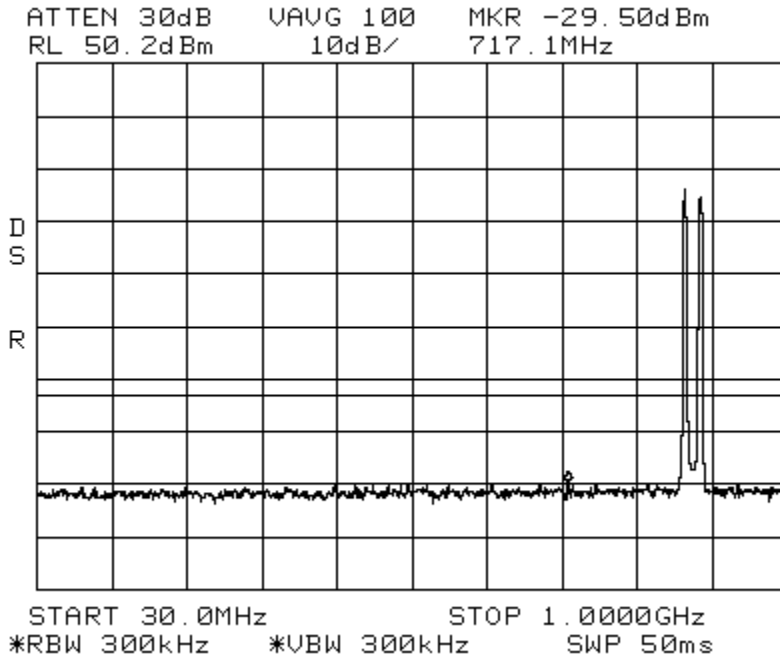

Intermodulation LTE 5 MHz Channel Bandwidth \_Apart CELL 20W  
Span: 1 GHz to 10 GHz RBW/VBW: 1 MHz

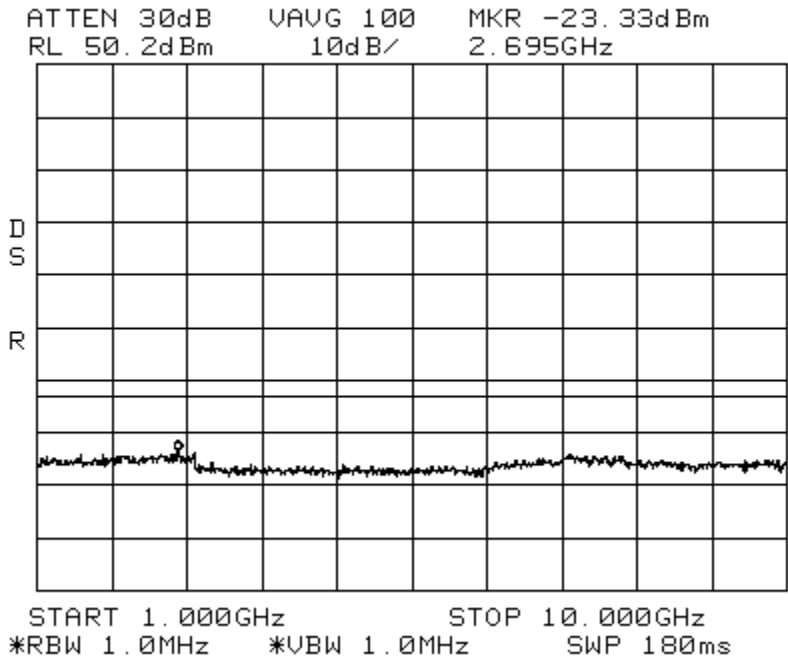



Intermodulation LTE 10 MHz Channel Bandwidth\_Low CELL 20W  
Center: 881.5 MHz Span: 70 MHz RBW/VBW: 100 kHz

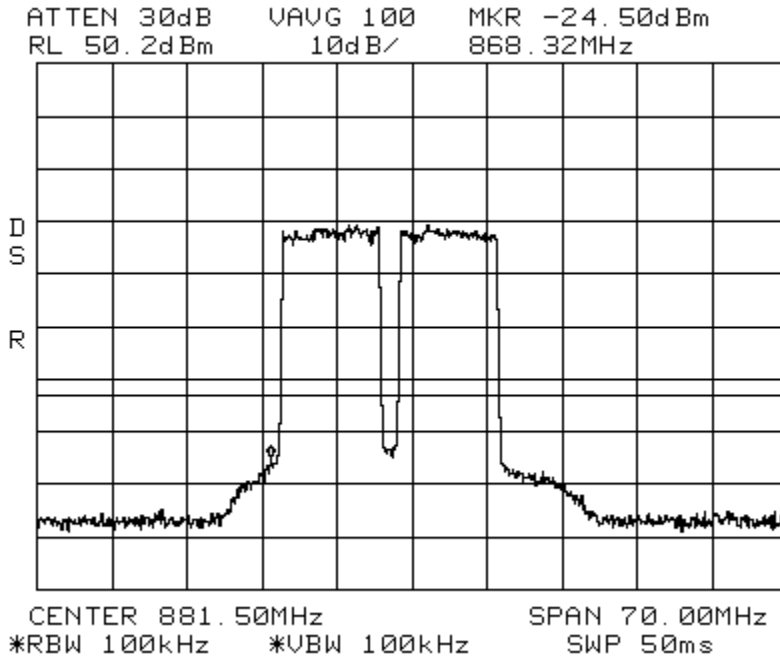

Intermodulation LTE 10 MHz Channel Bandwidth\_Low CELL 20W  
Span: 30 MHz to 1 GHz RBW/VBW: 300 kHz

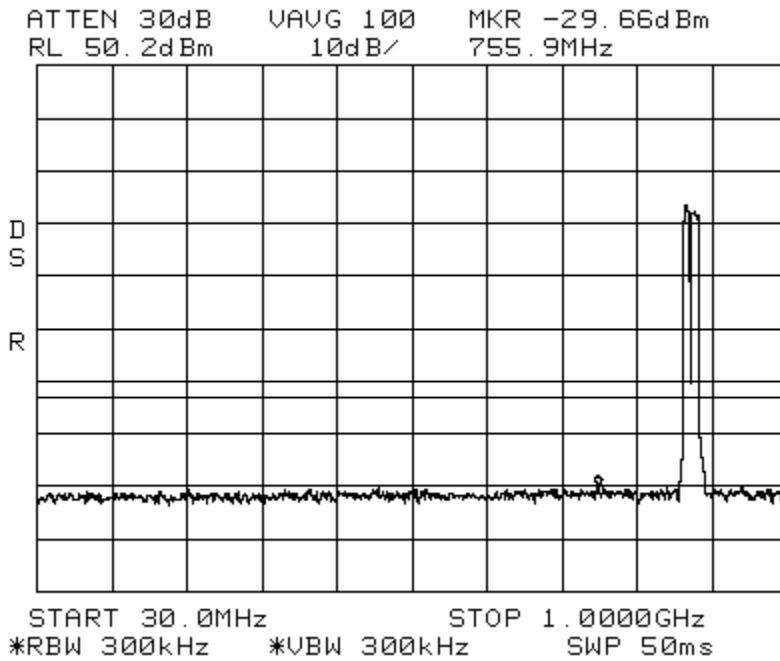

Intermodulation LTE 10 MHz Channel Bandwidth\_Low CELL 20W  
Span: 1 GHz to 10GHz RBW/VBW: 1 MHz

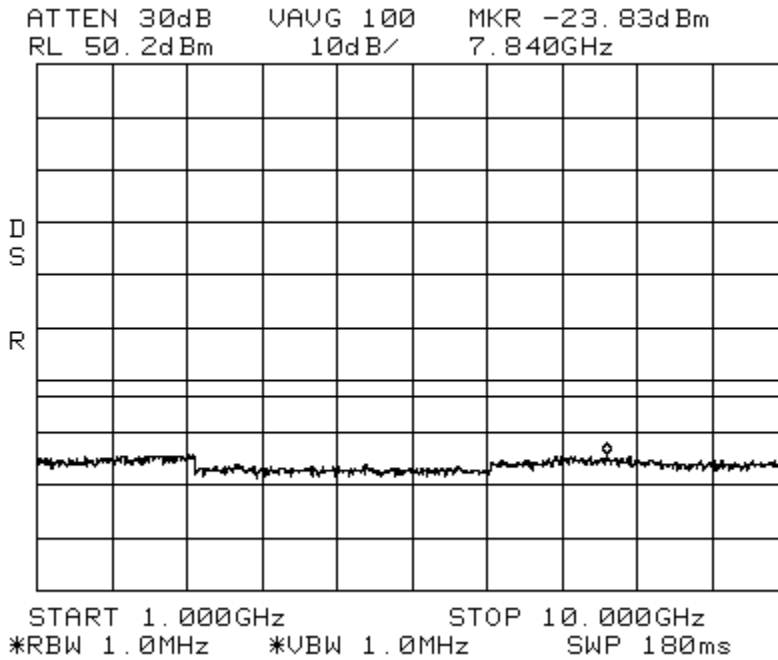

Intermodulation LTE 10 MHz Channel Bandwidth\_High CELL 20W  
Center: 881.5 MHz Span: 70 MHz RBW/VBW: 100 kHz

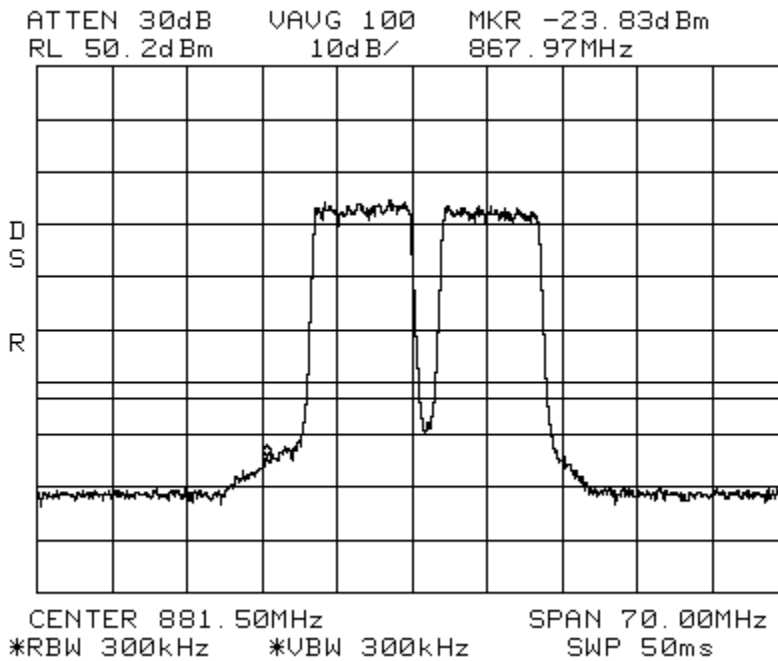

Intermodulation LTE 10 MHz Channel Bandwidth\_High CELL 20W  
Span: 30 MHz to 1 GHz RBW/VBW: 300 kHz

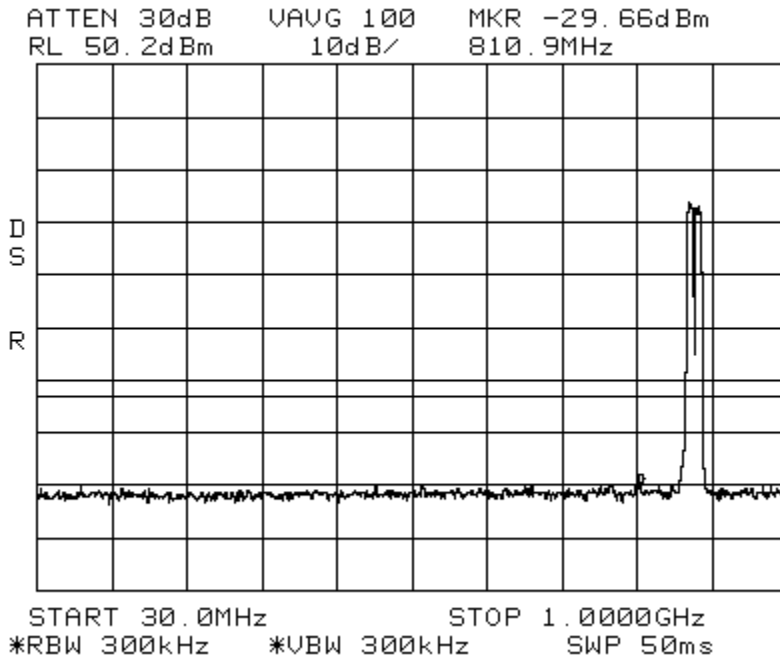

Intermodulation LTE 10 MHz Channel Bandwidth\_High CELL 20W  
Span: 1 GHz to 10 GHz RBW/VBW: 1 MHz

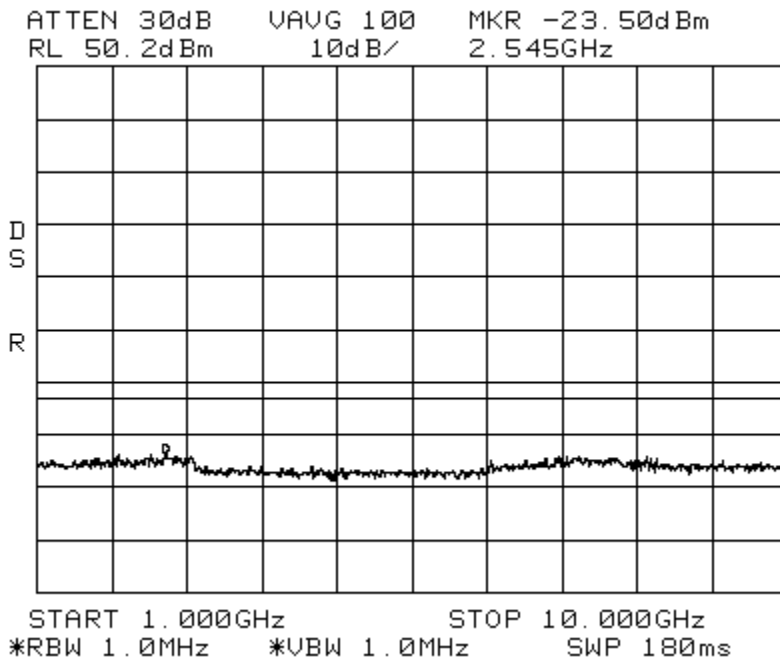

Intermodulation      LTE 10 MHz Channel Bandwidth\_Apart      CELL 20W  
Center: 881.5 MHz      Span: 175 MHz      RBW/VBW: 100 kHz

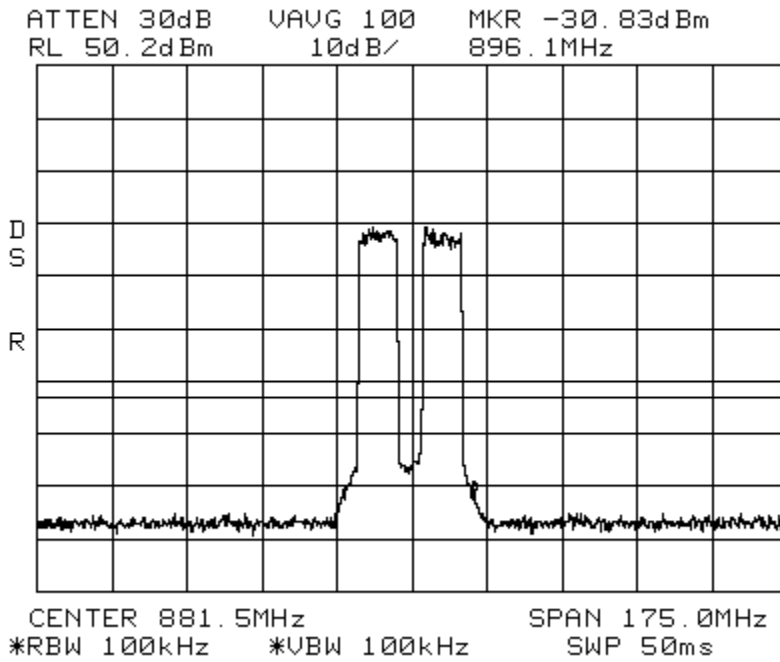

Intermodulation      LTE 10 MHz Channel Bandwidth\_Apart      CELL 20W  
Span: 30 MHz to 1 GHz      RBW/VBW: 300 kHz

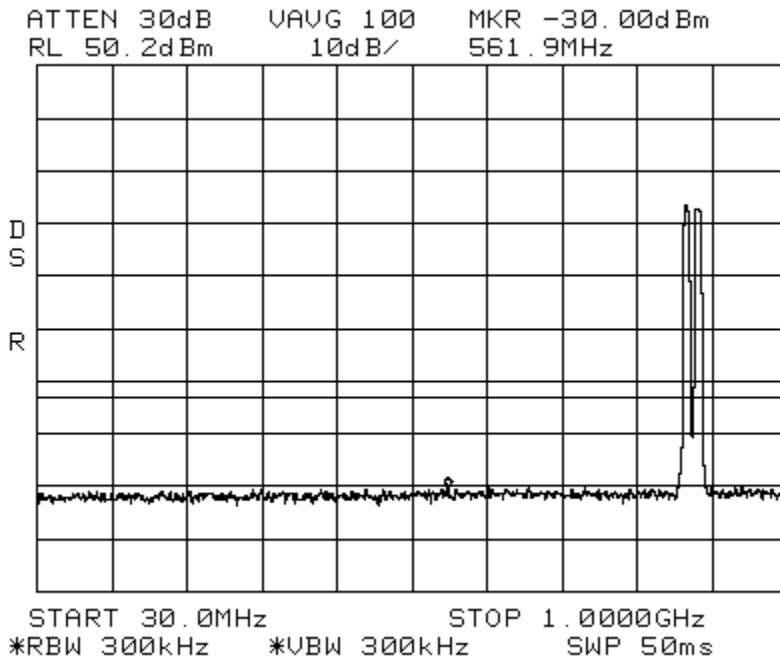

Intermodulation      LTE 10 MHz Channel Bandwidth\_Apart      CELL 20W  
Span: 1 GHz to 10 GHz      RBW/VBW: 1 MHz

ATTEN 30dB      VAUG 100      MKR -23.16dBm  
RL 50.2dBm      10dB/      2.875GHz

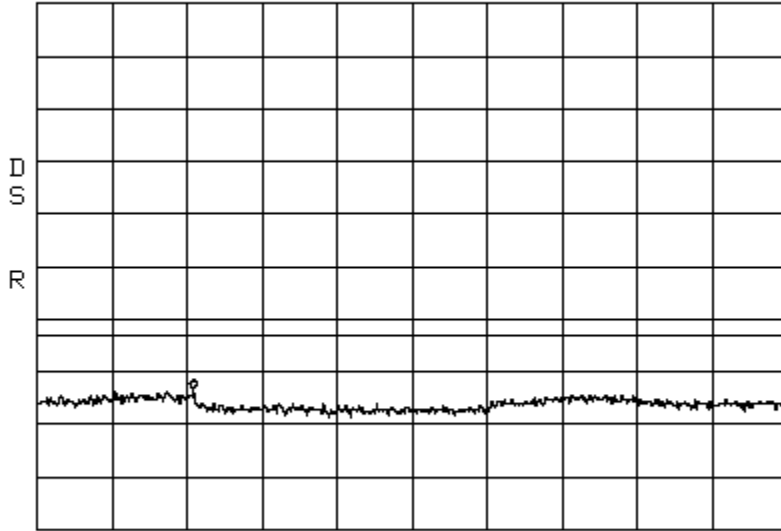

START 1.000GHz      STOP 10.000GHz  
\*RBW 1.0MHz      \*VBW 1.0MHz      SWP 180ms

Intermodulation      WCDMA\_Low      CELL 20W  
Center: 881.5 MHz      Span: 35 MHz      RBW/VBW: 100 kHz

ATTEN 30dB      VAUG 100      MKR -22.16dBm  
RL 50.2dBm      10dB/      883.66MHz



CENTER 881.50MHz      SPAN 35.00MHz  
\*RBW 100kHz      \*VBW 100kHz      SWP 50ms

Intermodulation  
Span: 30 MHz to 1 GHz

WCDMA\_Low  
CELL 20W  
RBW/VBW: 300 kHz

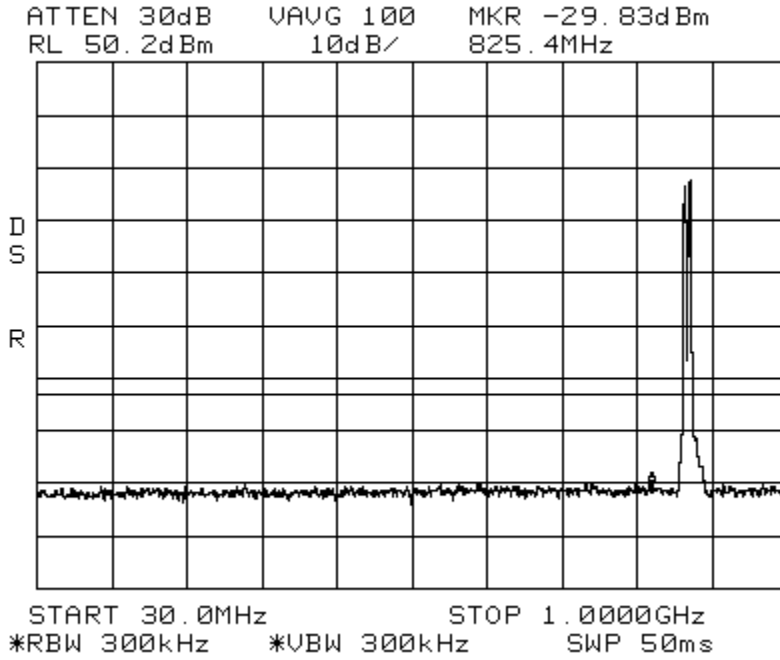

Intermodulation  
Span: 1 GHz to 10 GHz

WCDMA\_Low  
CELL 20W  
RBW/VBW: 1 MHz

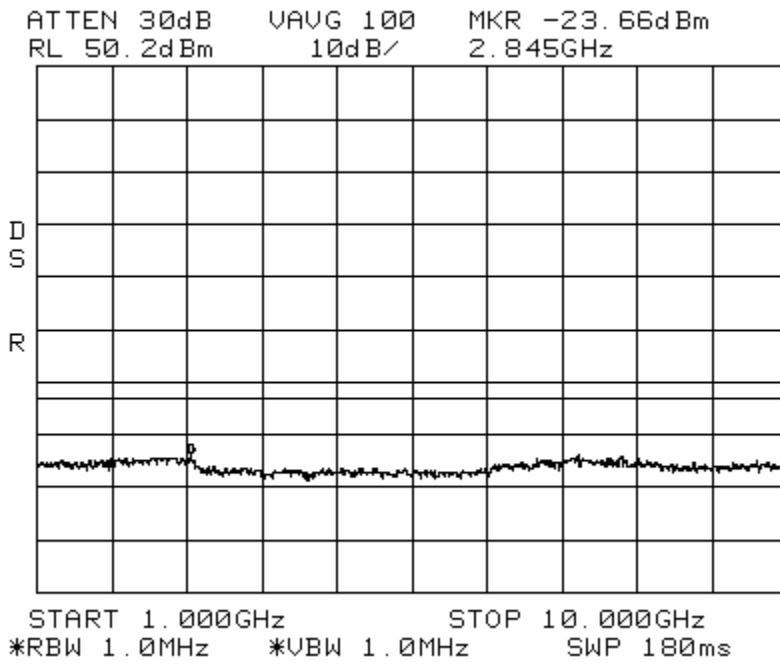

Intermodulation  
Center: 881.5 MHz

WCDMA\_High  
Span: 35 MHz

CELL 20W  
RBW/VBW: 100 kHz

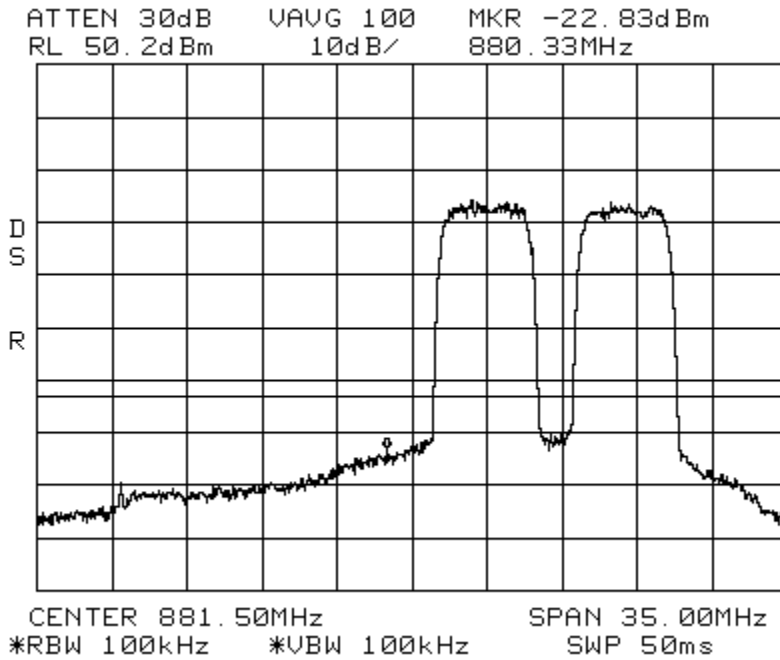

Intermodulation  
Span: 30 MHz to 1 GHz

WCDMA\_High

CELL 20W  
RBW/VBW: 300 kHz

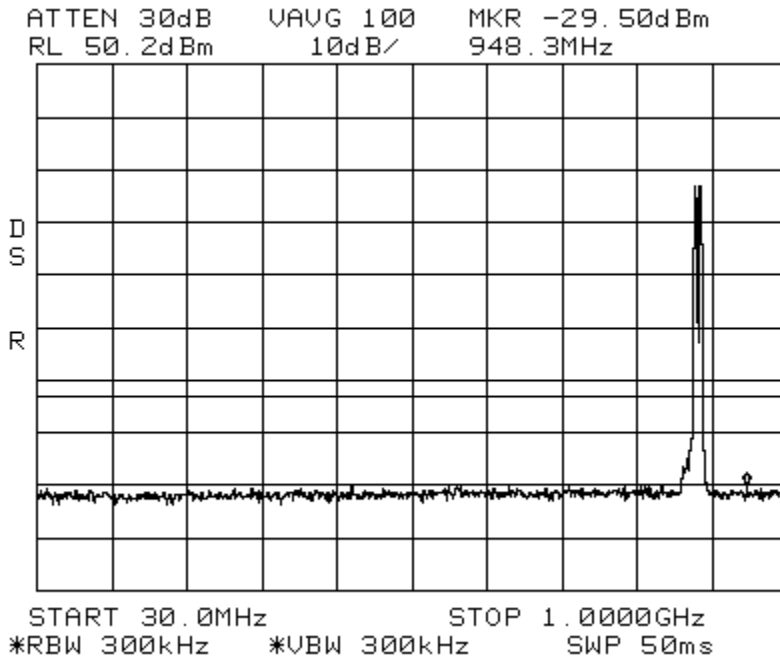

Intermodulation  
Span: 1 GHz to 10 GHz

WCDMA\_High

CELL 20W

RBW/VBW: 1 MHz

ATTEN 30dB    VAUG 100    MKR -23.16dBm  
RL 50.2dBm    10dB/    2.860GHz

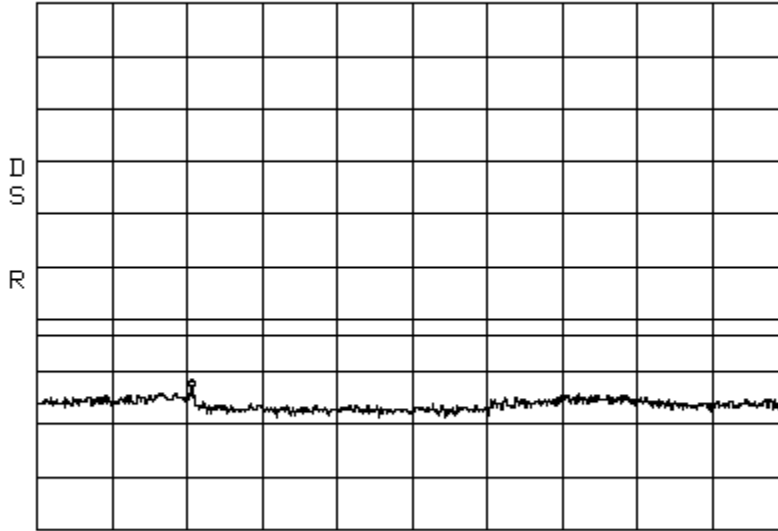

START 1.000GHz    STOP 10.000GHz  
\*RBW 1.0MHz    \*VBW 1.0MHz    SWP 180ms

Intermodulation  
Center: 881.5 MHz

WCDMA\_Apart  
Span: 75 MHz

CELL 20W  
RBW/VBW: 100 kHz

ATTEN 30dB    VAUG 100    MKR -34.00dBm  
RL 50.2dBm    10dB/    849.00MHz

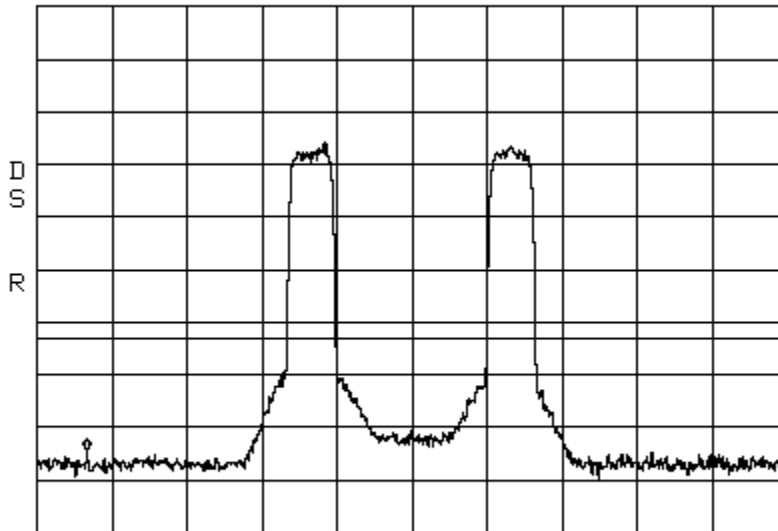

CENTER 881.50MHz    SPAN 75.00MHz  
\*RBW 100kHz    \*VBW 100kHz    SWP 50ms



Intermodulation

WCDMA\_Apart

CELL 20W

Span: 30 MHz to 1 GHz

RBW/VBW: 300 kHz

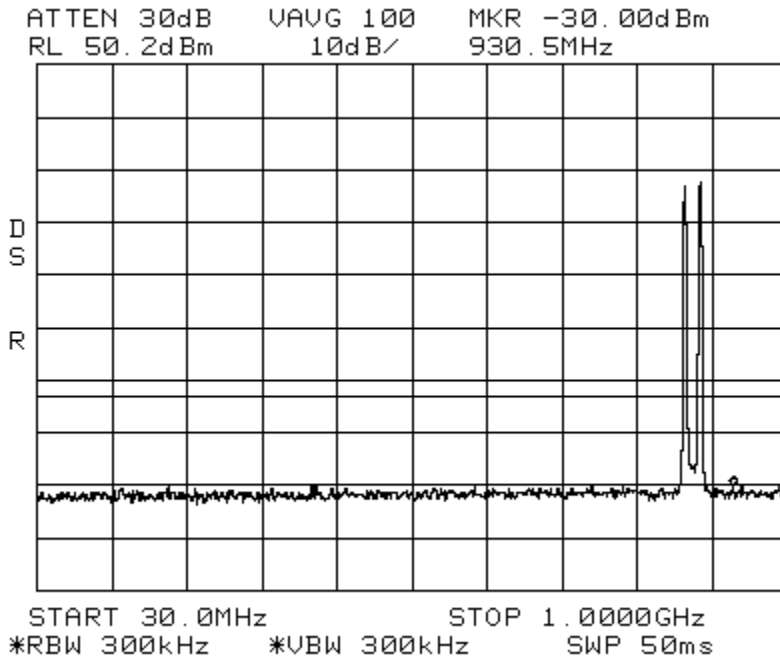

Intermodulation

WCDMA\_Apart

CELL 20W

Span: 1 GHz to 10 GHz

RBW/VBW: 1 MHz

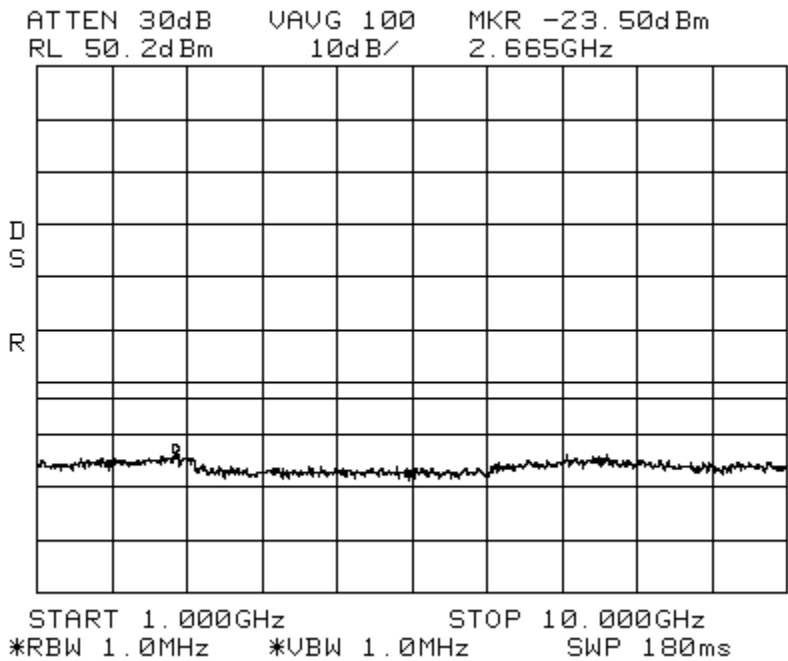

Intermodulation                      CDMA\_Low                      PCS 20W  
 Center: 1962.5 MHz                      Span: 90 MHz                      RBW/VBW: 100 kHz  
 ATTN 30dB      VAUG 100      MKR -26.66dBm  
 RL 50.2dBm      10dB/      1.94735GHz

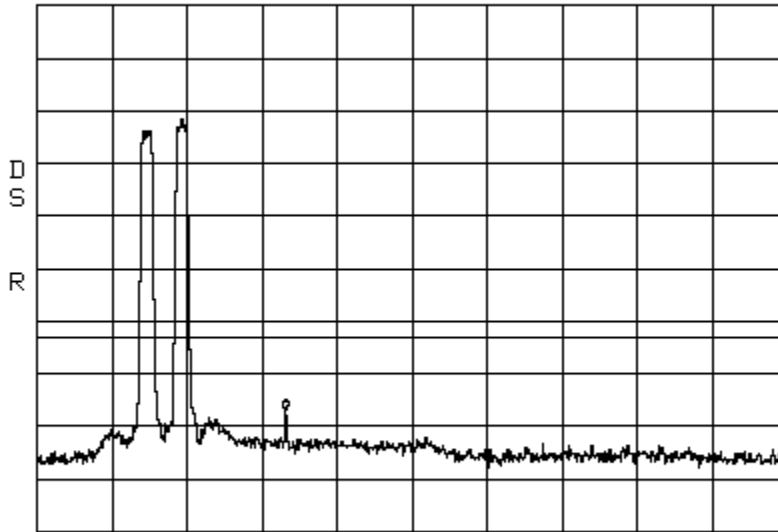

CENTER 1.96250GHz                      SPAN 90.00MHz  
 \*RBW 100kHz      \*VBW 100kHz      SWP 50ms

Intermodulation                      CDMA\_Low                      PCS 20W  
 Span: 30 MHz to 1 GHz                      RBW/VBW: 300 kHz

ATTN 30dB      VAUG 100      MKR -29.83dBm  
 RL 50.2dBm      10dB/      259.6MHz

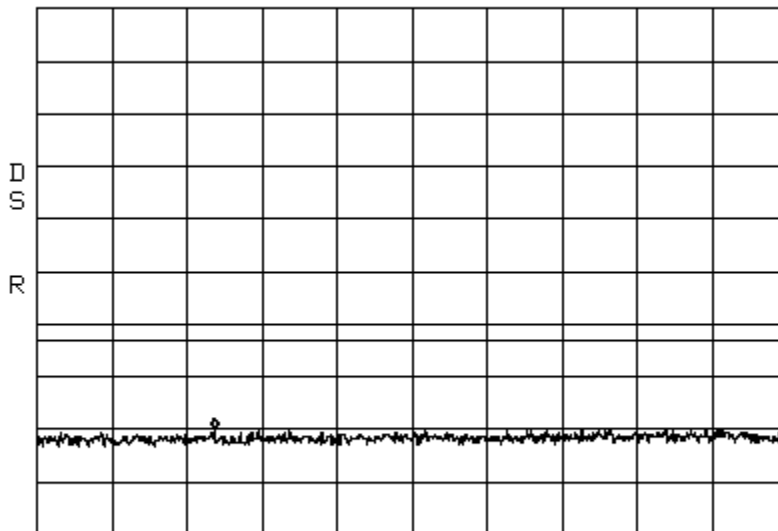

START 30.0MHz                      STOP 1.0000GHz  
 \*RBW 300kHz      \*VBW 300kHz      SWP 50ms

Intermodulation  
Span: 1 GHz to 5 GHz

CDMA\_Low PCS 20W  
RBW/VBW: 1 MHz

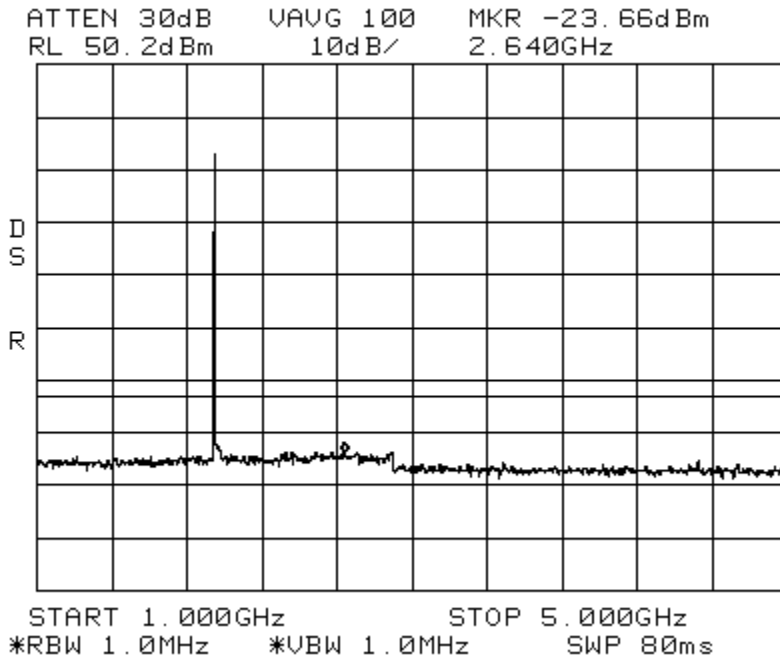

Intermodulation  
Span: 5 GHz to 20 GHz

CDMA\_Low PCS 20W  
RBW/VBW: 1 MHz

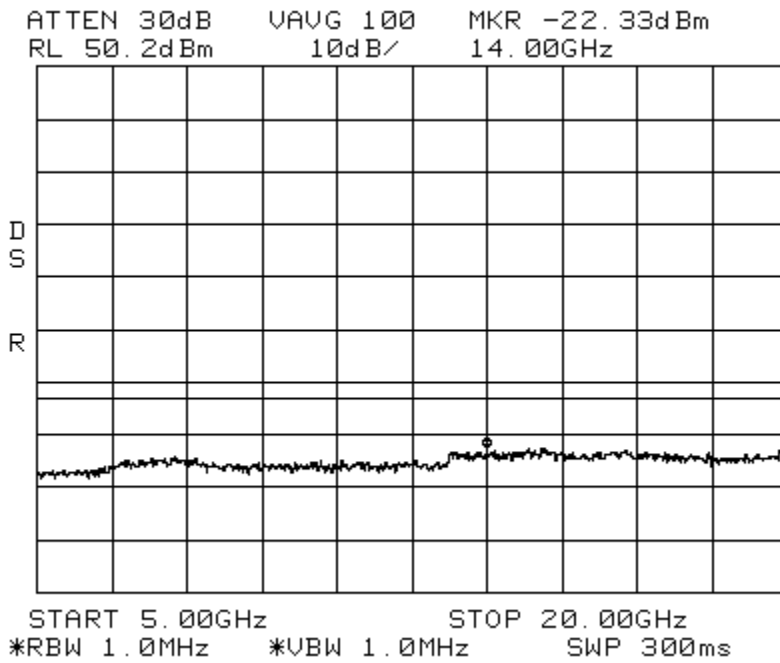

Intermodulation  
Center: 1962.5 MHz

CDMA\_High  
Span: 90 MHz

PCS 20W  
RBW/VBW: 100 kHz

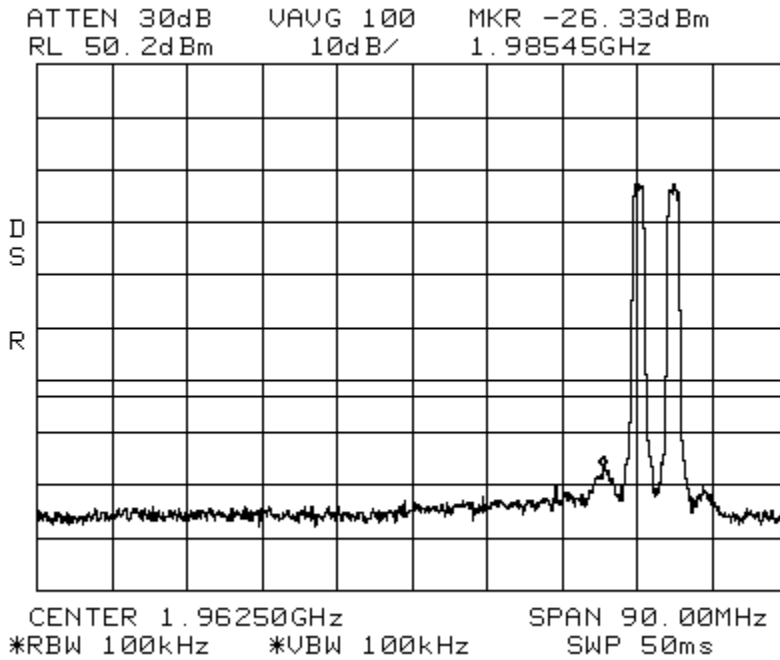

Intermodulation  
Span: 30 MHz to 1 GHz

CDMA\_High    PCS 20W  
RBW/VBW: 300 kHz

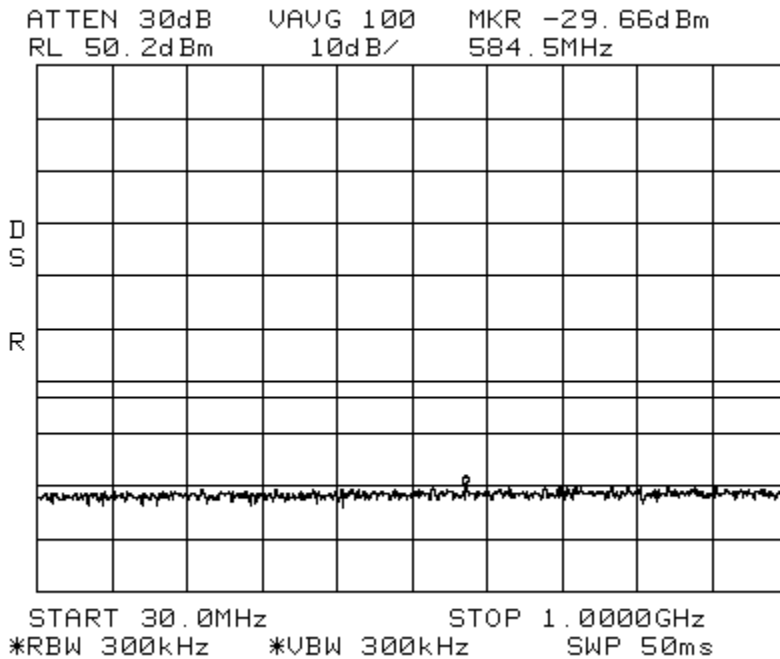

Intermodulation  
Span: 1 GHz to 5 GHz

CDMA\_High

PCS 20W

RBW/VBW: 1 MHz

ATTEN 30dB    VAUG 100    MKR -23.33dBm  
RL 50.2dBm    10dB/    2.567GHz

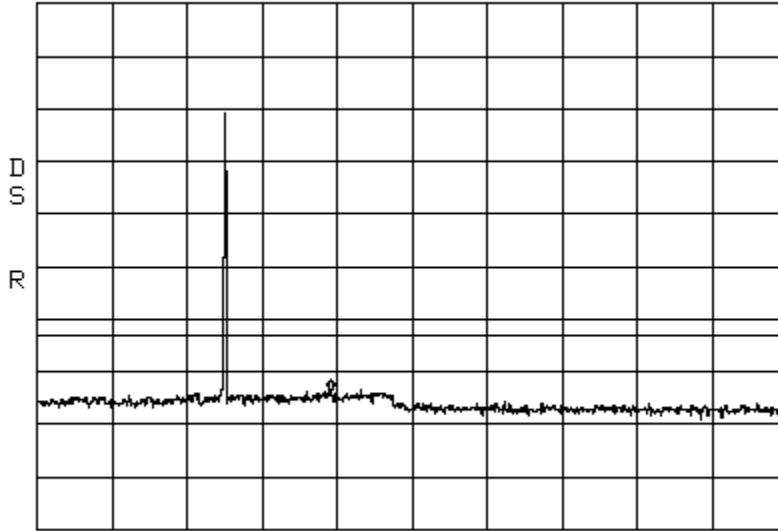

START 1.000GHz    STOP 5.000GHz  
\*RBW 1.0MHz    \*VBW 1.0MHz    SWP 80ms

Intermodulation  
Span: 5 GHz to 20 GHz

CDMA\_High

PCS 20W

RBW/VBW: 1 MHz

ATTEN 30dB    VAUG 100    MKR -22.33dBm  
RL 50.2dBm    10dB/    14.15GHz

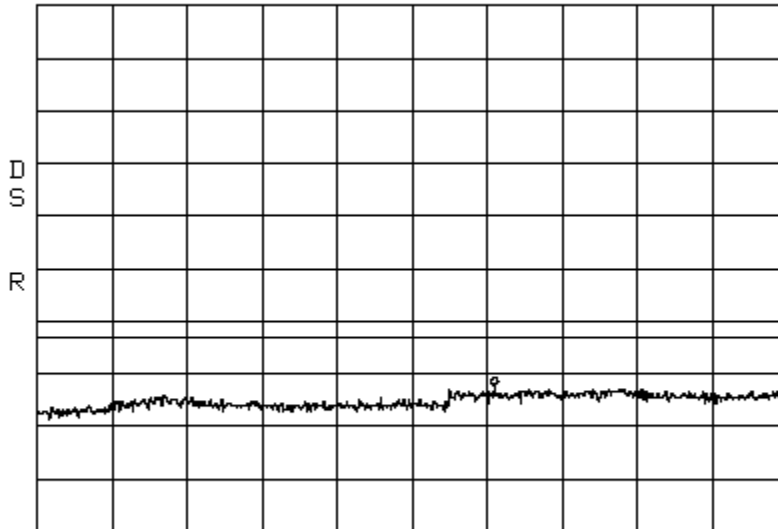

START 5.000GHz    STOP 20.000GHz  
\*RBW 1.0MHz    \*VBW 1.0MHz    SWP 300ms

Intermodulation  
Center: 1962.5 MHz

CDMA\_Apart  
Span: 175 MHz

PCS 20W  
RBW/VBW: 100 kHz

ATTEN 30dB    VAUG 100    MKR -31.83dBm  
RL 50.2dBm    10dB/    1.9823GHz

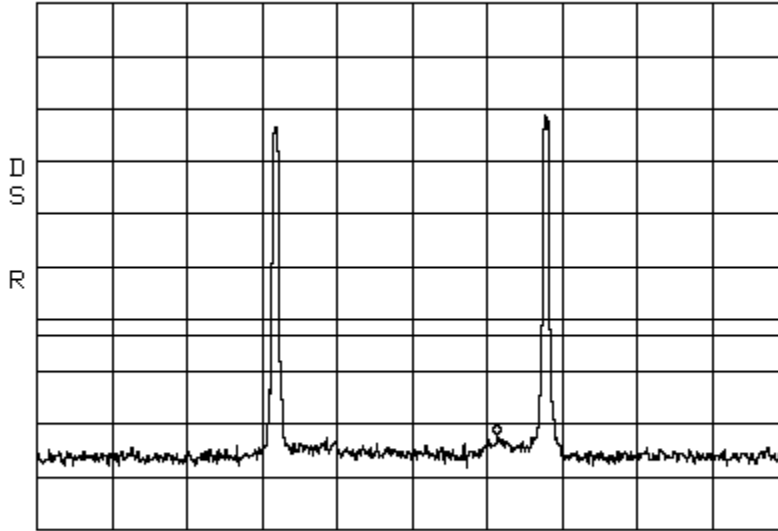

CENTER 1.9625GHz    SPAN 175.0MHz  
\*RBW 100kHz    \*VBW 100kHz    SWP 50ms

Intermodulation  
Span: 30 MHz to 1 GHz

CDMA\_Apart    PCS 20W  
RBW/VBW: 300 kHz

ATTEN 30dB    VAUG 100    MKR -28.83dBm  
RL 50.2dBm    10dB/    961.2MHz

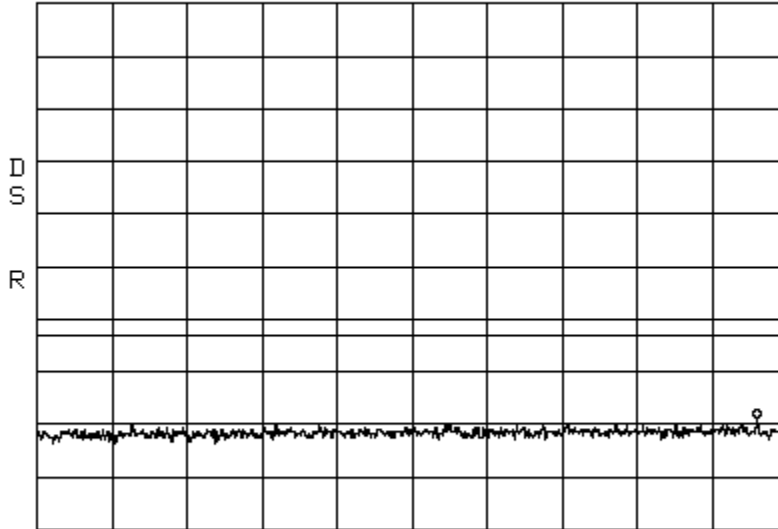

START 30.0MHz    STOP 1.0000GHz  
\*RBW 300kHz    \*VBW 300kHz    SWP 50ms

Intermodulation  
Span: 1 GHz to 5 GHz

CDMA\_Apart PCS 20W  
RBW/VBW: 1 MHz

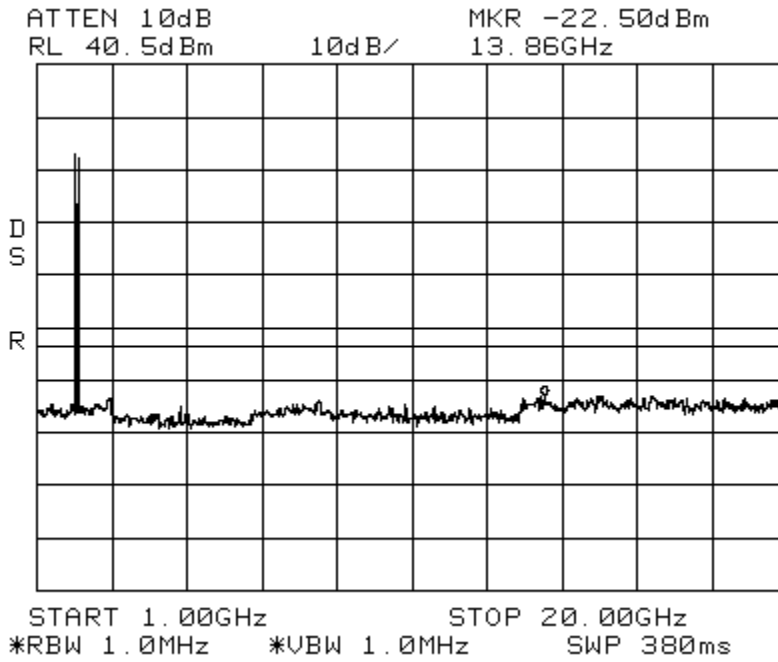

Intermodulation  
Span: 5 GHz to 20 GHz

CDMA\_Apart PCS 20W  
RBW/VBW: 1 MHz

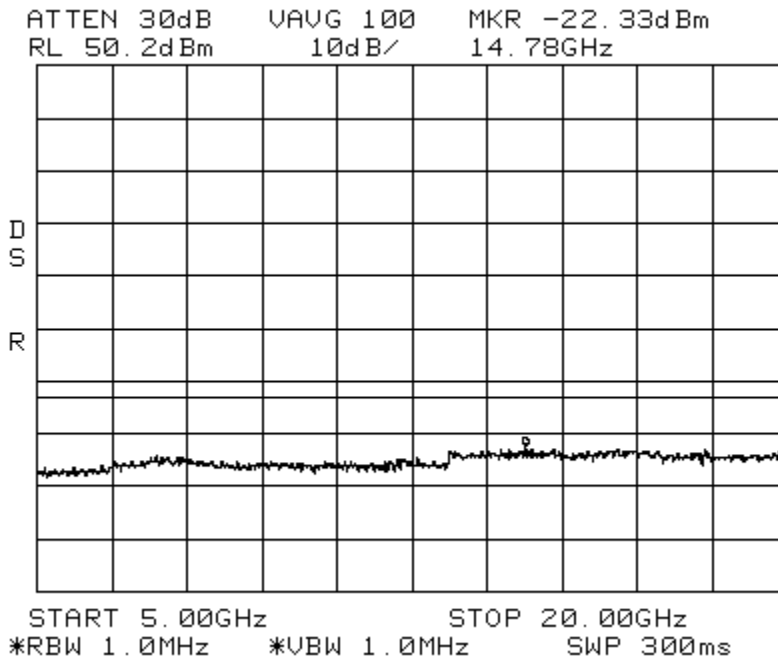

Intermodulation  
Center: 1962.5 MHz

EDGE\_Low  
Span: 90 MHz

PCS 20W  
RBW/VBW: 100 kHz

ATTEN 30dB    VAVG 100    MKR -22.66dBm  
RL 50.2dBm    10dB/    1.93775GHz

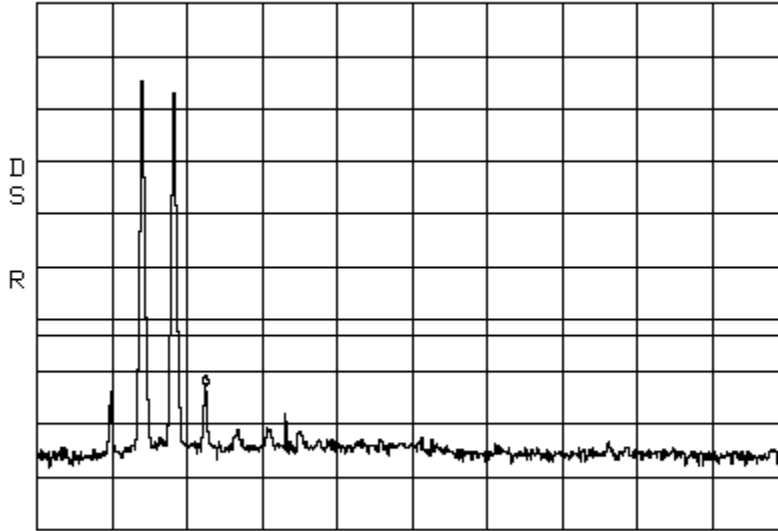

CENTER 1.96250GHz    SPAN 90.00MHz  
\*RBW 100kHz    \*VBW 100kHz    SWP 50ms

Intermodulation  
Span: 30 MHz to 1 GHz

EDGE\_Low

PCS 20W  
RBW/VBW: 300 kHz

ATTEN 30dB    VAVG 100    MKR -29.16dBm  
RL 50.2dBm    10dB/    885.2MHz

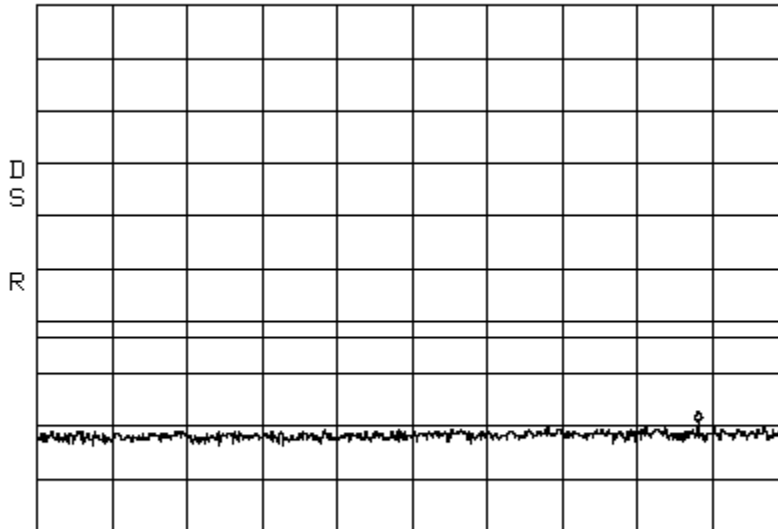

START 30.0MHz    STOP 1.0000GHz  
\*RBW 300kHz    \*VBW 300kHz    SWP 50ms



Intermodulation  
Span: 1 GHz to 5 GHz

EDGE\_Low PCS 20W  
RBW/VBW: 1 MHz

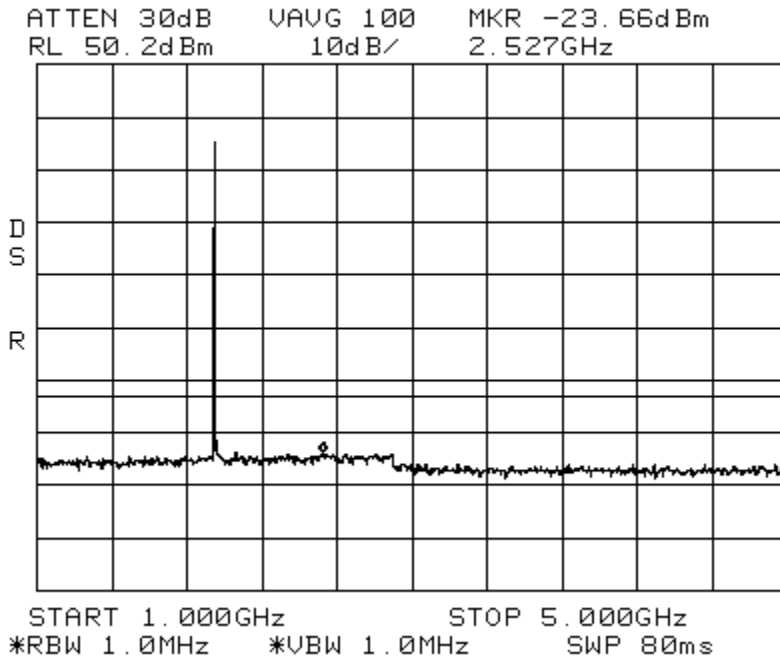

Intermodulation  
Span: 5 GHz to 20 GHz

EDGE\_Low PCS 20W  
RBW/VBW: 1 MHz

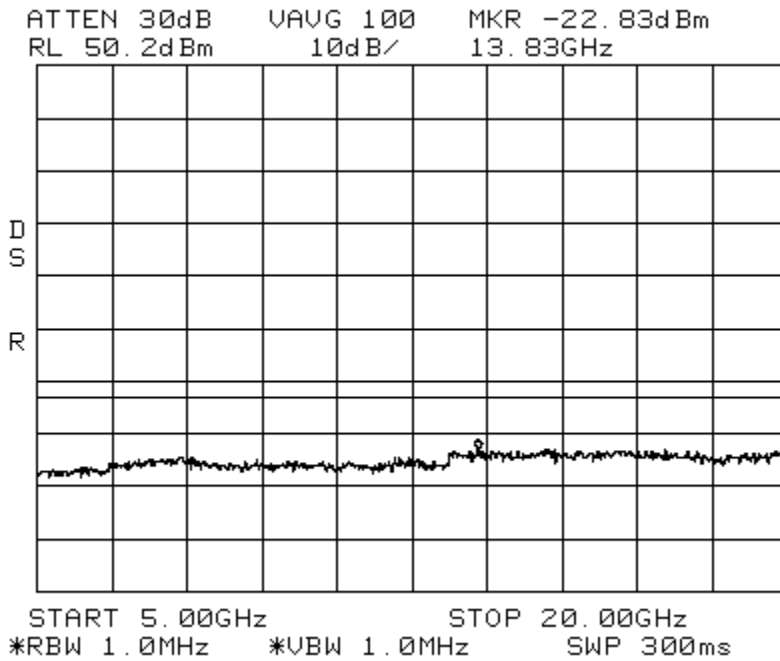

Intermodulation  
Center: 1962.5 MHz

EDGE\_High  
Span: 90 MHz

PCS 20W  
RBW/VBW: 100 kHz

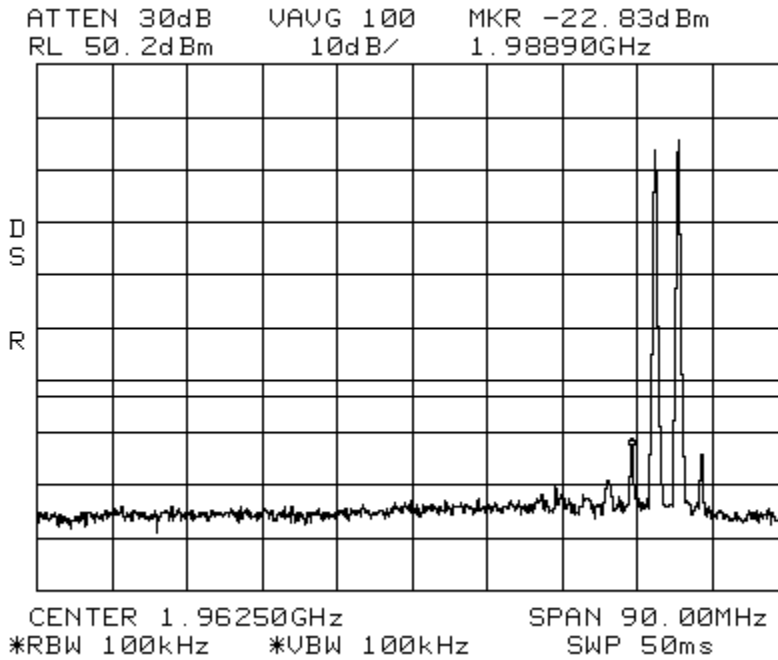

Intermodulation  
Span: 30 MHz to 1 GHz

EDGE\_High  
RBW/VBW: 300 kHz

PCS 20W

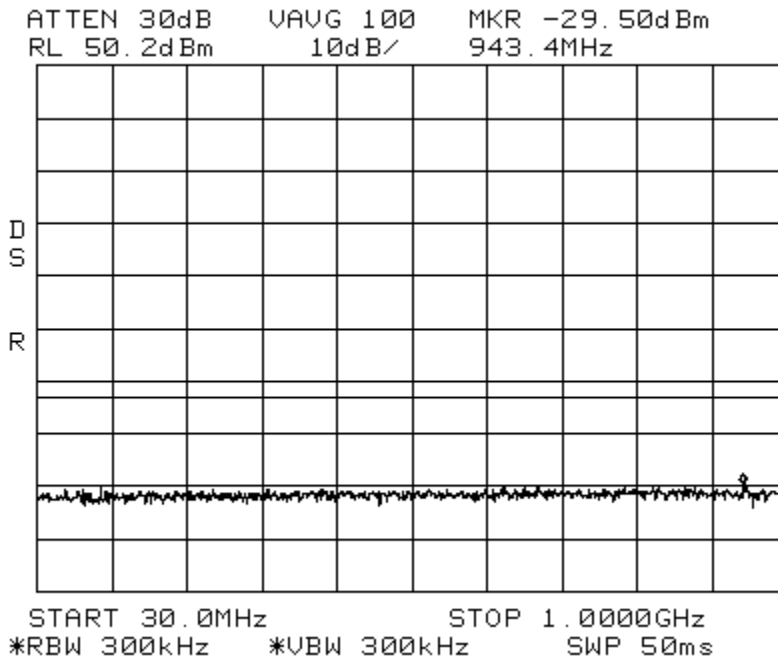

Intermodulation  
Span: 1 GHz to 5 GHz

EDGE\_High

PCS 20W

RBW/VBW: 1 MHz

ATTEN 30dB    VAUG 100    MKR -23.33dBm  
RL 50.2dBm    10dB/    2.673GHz

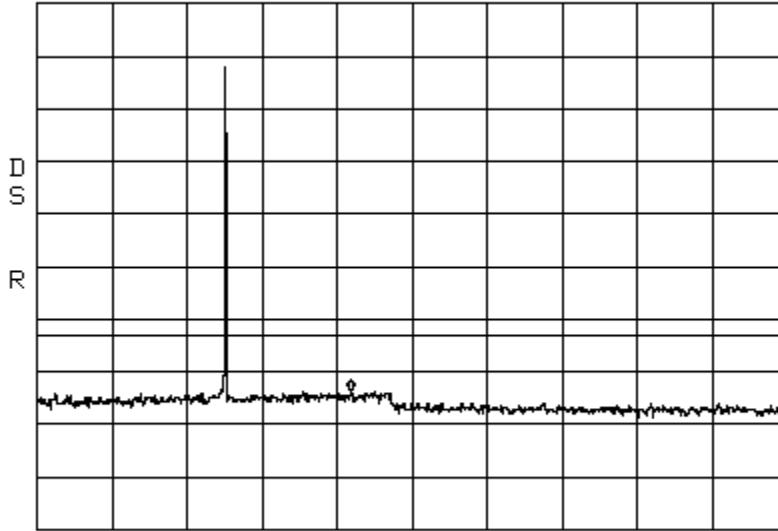

START 1.000GHz    STOP 5.000GHz  
\*RBW 1.0MHz    \*VBW 1.0MHz    SWP 80ms

Intermodulation  
Span: 5 GHz to 20 GHz

EDGE\_High

PCS 20W

RBW/VBW: 1 MHz

ATTEN 30dB    VAUG 100    MKR -22.16dBm  
RL 50.2dBm    10dB/    16.85GHz

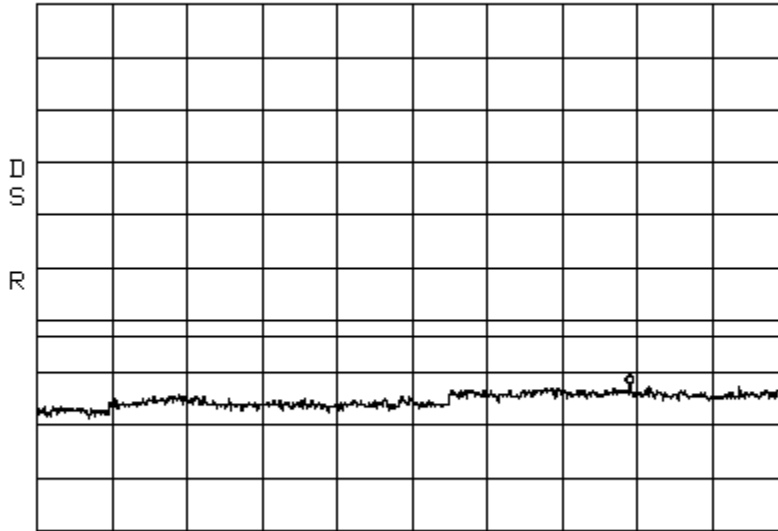

START 5.00GHz    STOP 20.00GHz  
\*RBW 1.0MHz    \*VBW 1.0MHz    SWP 300ms

Intermodulation  
Center: 1962.5 MHz

EDGE\_Apart  
Span: 175 MHz

PCS 20W  
RBW/VBW: 100 kHz

ATTEN 30dB    VAUG 100    MKR -33.33dBm  
RL 50.2dBm    10dB/    2.0392GHz

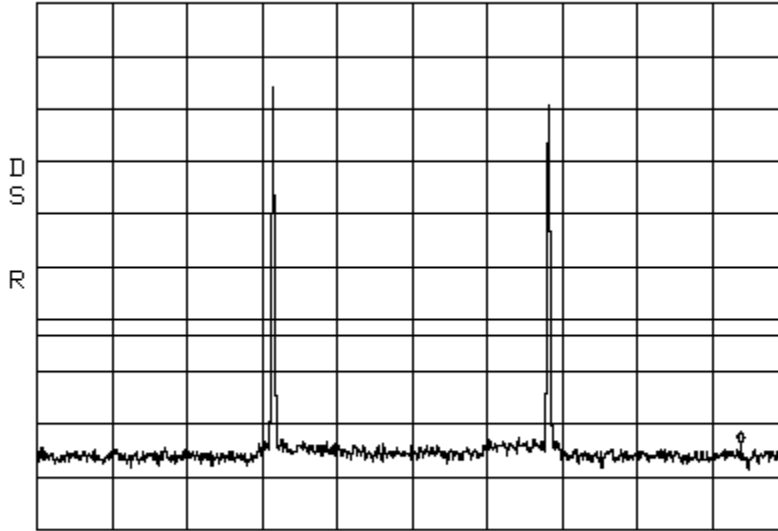

CENTER 1.9625GHz    SPAN 175.0MHz  
\*RBW 100kHz    \*VBW 100kHz    SWP 50ms

Intermodulation  
Span: 30 MHz to 1 GHz

EDGE\_Apart    PCS 20W  
RBW/VBW: 300 kHz

ATTEN 30dB    VAUG 100    MKR -29.33dBm  
RL 50.2dBm    10dB/    925.6MHz

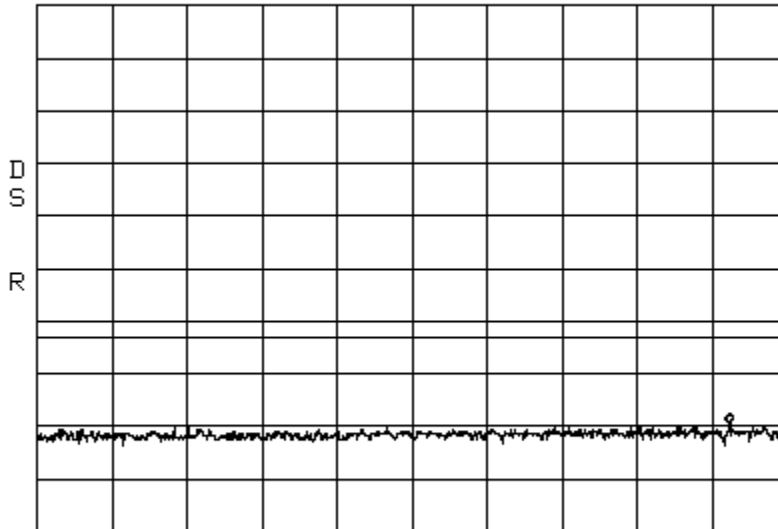

START 30.0MHz    STOP 1.0000GHz  
\*RBW 300kHz    \*VBW 300kHz    SWP 50ms

Intermodulation  
Span: 1 GHz to 5 GHz

EDGE\_Apart

PCS 20W

RBW/VBW: 1 MHz

ATTEN 30dB VAUG 100 MKR -23.50dBm  
RL 50.2dBm 10dB/ 2.500GHz

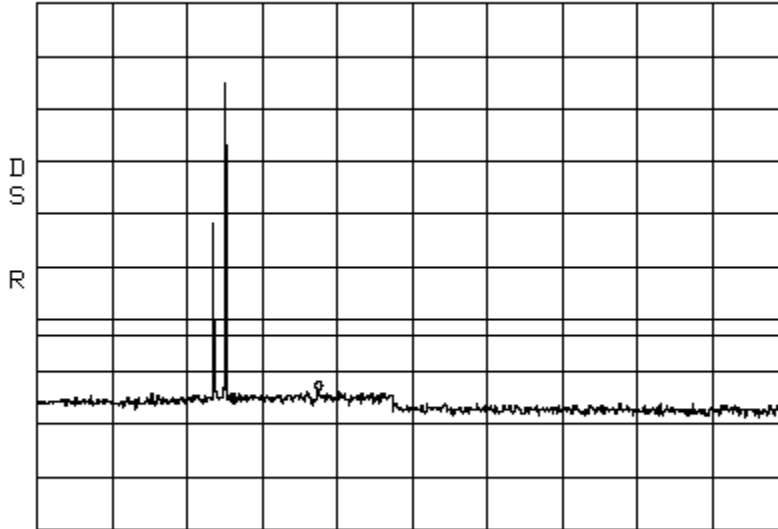

START 1.000GHz STOP 5.000GHz  
\*RBW 1.0MHz \*VBW 1.0MHz SWP 80ms

Intermodulation  
Span: 5 GHz to 20 GHz

EDGE\_Apart

PCS 20W

RBW/VBW: 1 MHz

ATTEN 30dB VAUG 100 MKR -22.00dBm  
RL 50.2dBm 10dB/ 14.20GHz

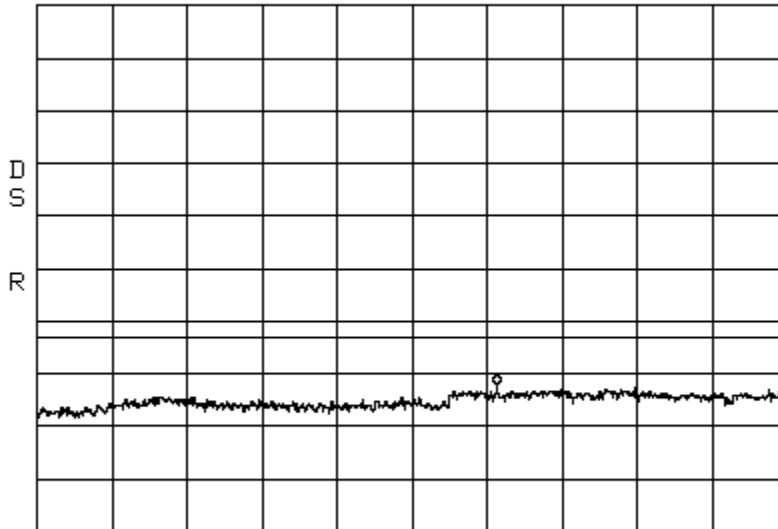

START 5.00GHz STOP 20.00GHz  
\*RBW 1.0MHz \*VBW 1.0MHz SWP 300ms

Intermodulation  
Center: 1962.5 MHz

GSM\_Low  
Span: 90 MHz

PCS 20W  
RBW/VBW: 100 kHz

ATTEN 30dB    VAUG 100    MKR -27.16dBm  
RL 50.2dBm    10dB/    1.92635GHz

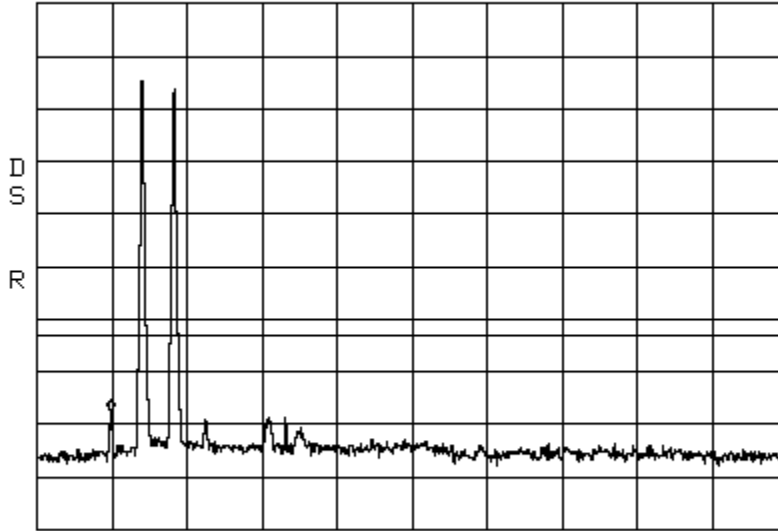

CENTER 1.96250GHz    SPAN 90.00MHz  
\*RBW 100kHz    \*VBW 100kHz    SWP 50ms

Intermodulation  
Span: 30 MHz to 1 GHz

GSM\_Low    PCS 20W  
RBW/VBW: 300 kHz

ATTEN 30dB    VAUG 100    MKR -29.50dBm  
RL 50.2dBm    10dB/    642.7MHz

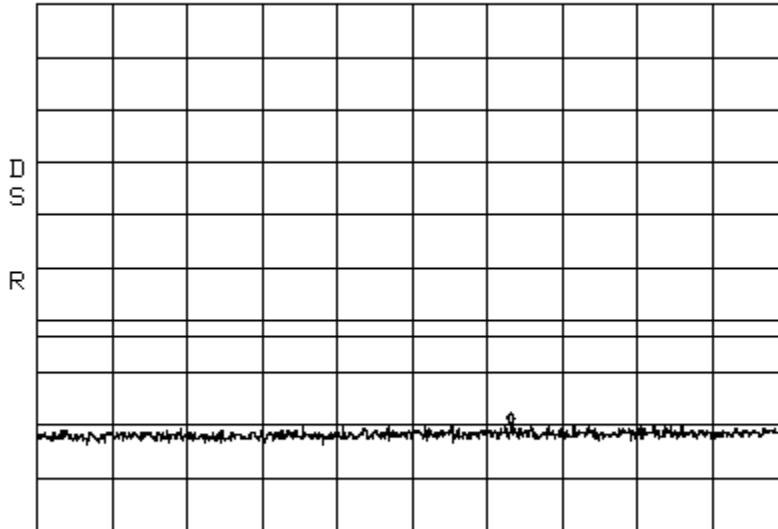

START 30.0MHz    STOP 1.0000GHz  
\*RBW 300kHz    \*VBW 300kHz    SWP 50ms

Intermodulation  
Span: 1 GHz to 5 GHz

GSM\_Low

PCS 20W

RBW/VBW: 1 MHz

ATTEN 30dB    VAUG 100    MKR -24.50dBm  
RL 50.2dBm    10dB/    1.413GHz

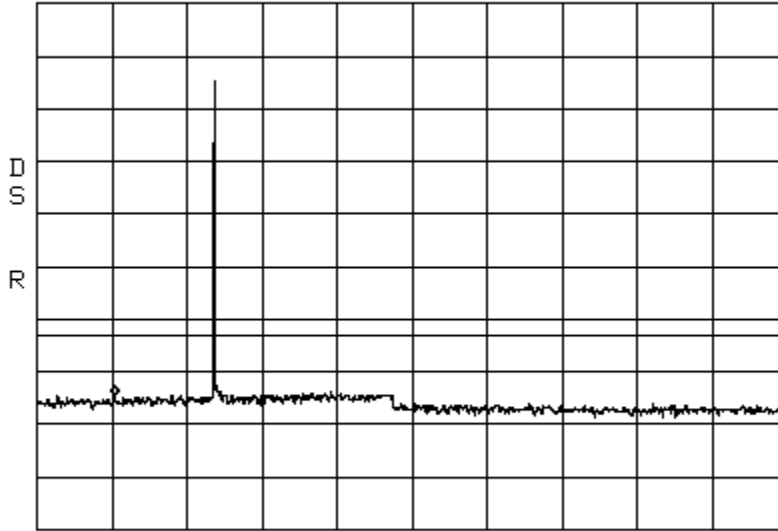

START 1.000GHz    STOP 5.000GHz  
\*RBW 1.0MHz    \*VBW 1.0MHz    SWP 80ms

Intermodulation  
Span: 5 GHz to 20 GHz

GSM\_Low

PCS 20W

RBW/VBW: 1 MHz

ATTEN 30dB    VAUG 100    MKR -22.66dBm  
RL 50.2dBm    10dB/    15.25GHz

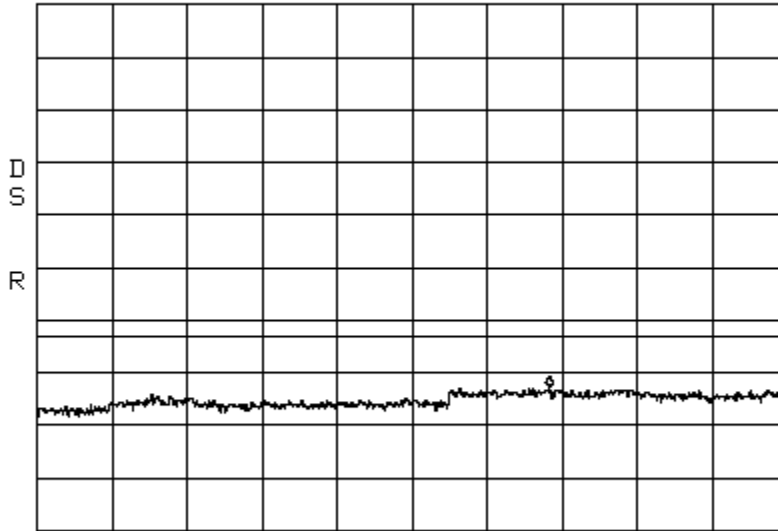

START 5.000GHz    STOP 20.000GHz  
\*RBW 1.0MHz    \*VBW 1.0MHz    SWP 300ms

Intermodulation  
Center: 1962.5 MHz

GSM\_High  
Span: 90 MHz

PCS 20W  
RBW/VBW: 100 kHz

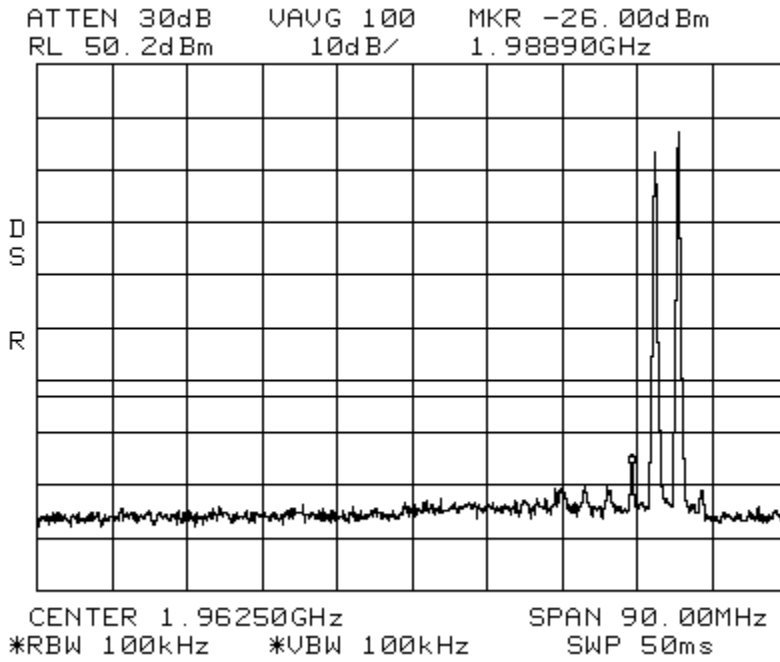

Intermodulation  
Span: 30 MHz to 1 GHz

GSM\_High    PCS 20W  
RBW/VBW: 300 kHz

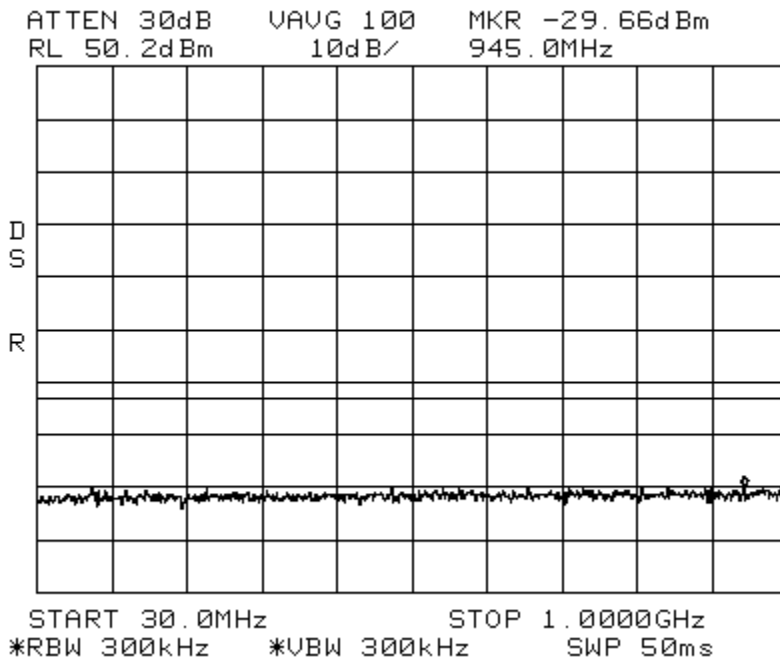



Intermodulation  
Span: 1 GHz to 5 GHz

GSM\_High PCS 20W  
RBW/VBW: 1 MHz

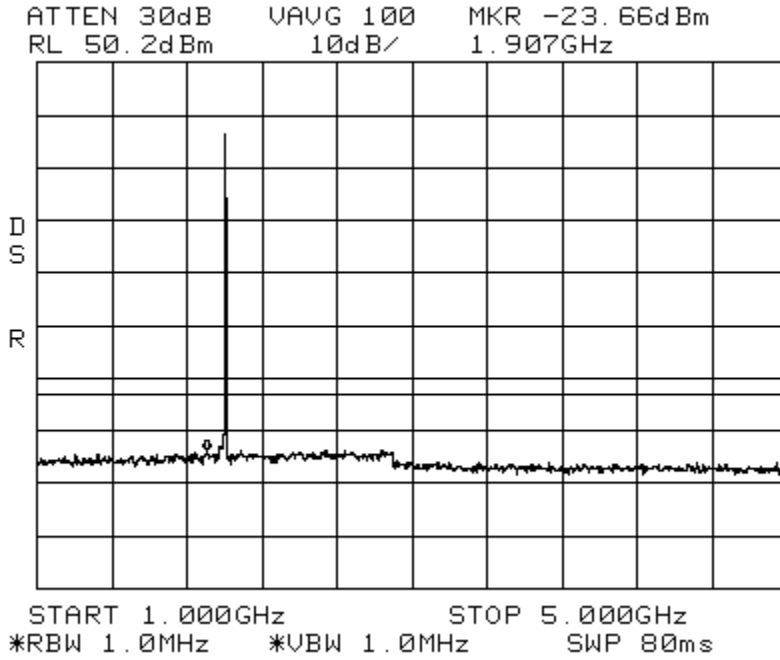

Intermodulation  
Span: 5 GHz to 20 GHz

GSM\_High PCS 20W  
RBW/VBW: 1 MHz

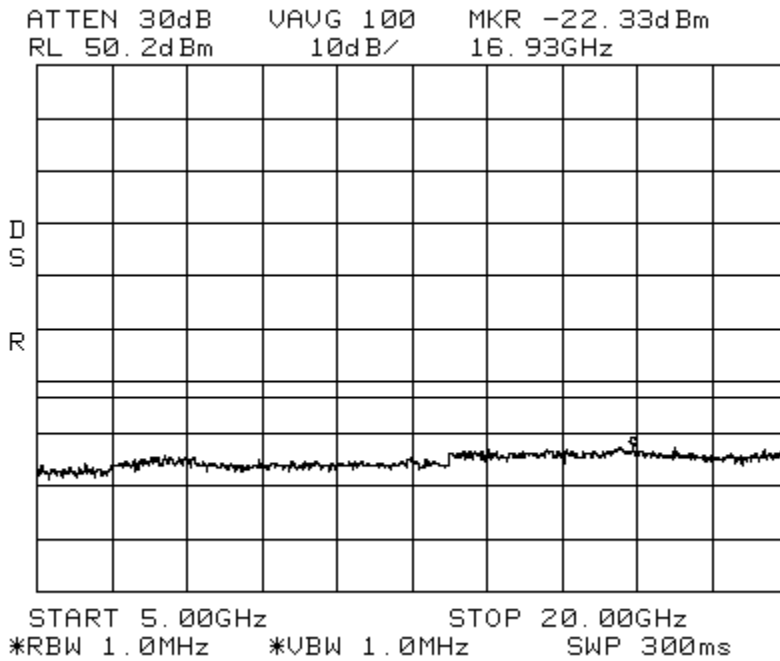

Intermodulation  
Center: 1962.5 MHz

GSM\_Apart  
Span: 175 MHz

PCS 20W  
RBW/VBW: 100 kHz

ATTEN 30dB    VAVG 100    MKR -32.83dBm  
RL 50.2dBm    10dB/    1.9444GHz

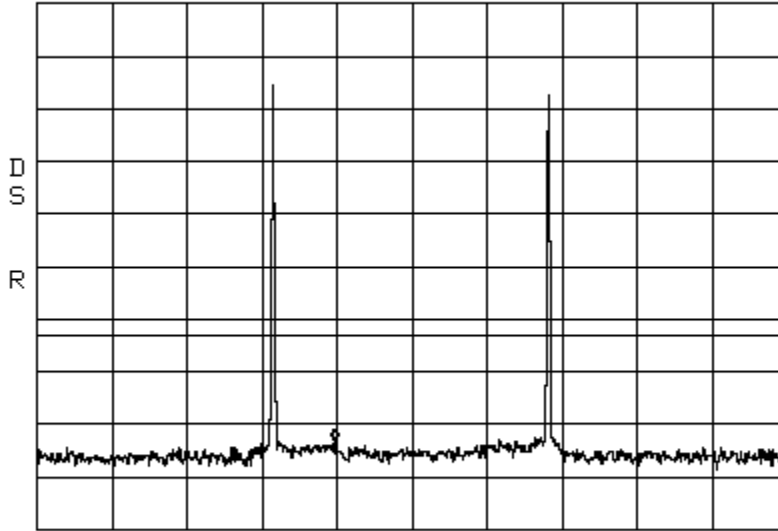

CENTER 1.9625GHz    SPAN 175.0MHz  
\*RBW 100kHz    \*VBW 100kHz    SWP 50ms

Intermodulation  
Span: 30 MHz to 1 GHz

GSM\_Apart    PCS 20W  
RBW/VBW: 300 kHz

ATTEN 30dB    VAVG 100    MKR -29.83dBm  
RL 50.2dBm    10dB/    928.9MHz

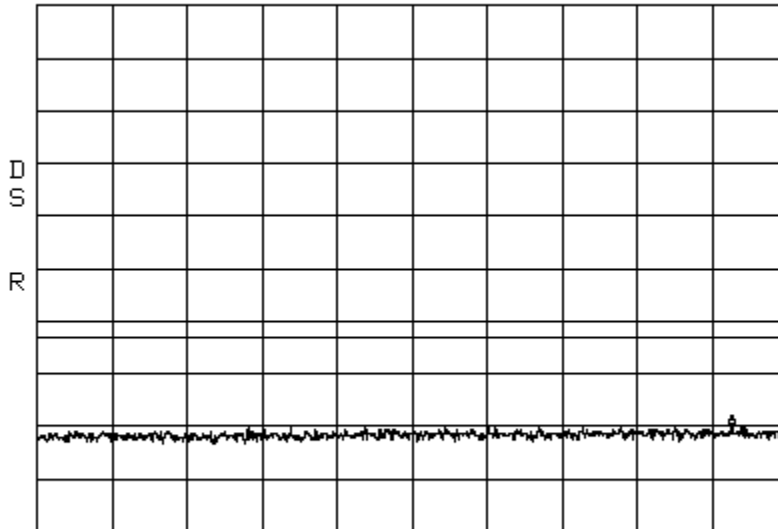

START 30.0MHz    STOP 1.0000GHz  
\*RBW 300kHz    \*VBW 300kHz    SWP 50ms

Intermodulation  
Span: 1 GHz to 5 GHz

GSM\_Apart

PCS 20W

RBW/VBW: 1 MHz

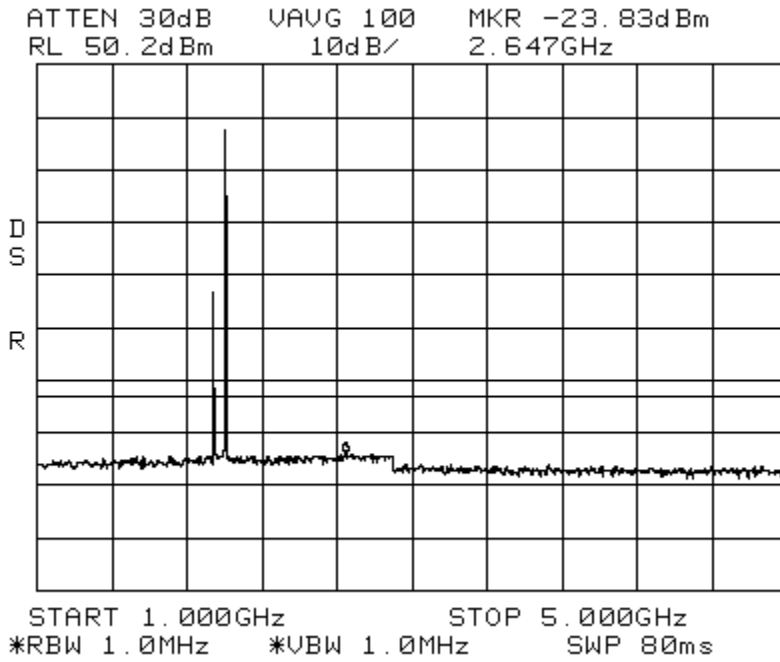

Intermodulation  
Span: 5 GHz to 20 GHz

GSM\_Apart

PCS 20W

RBW/VBW: 1 MHz

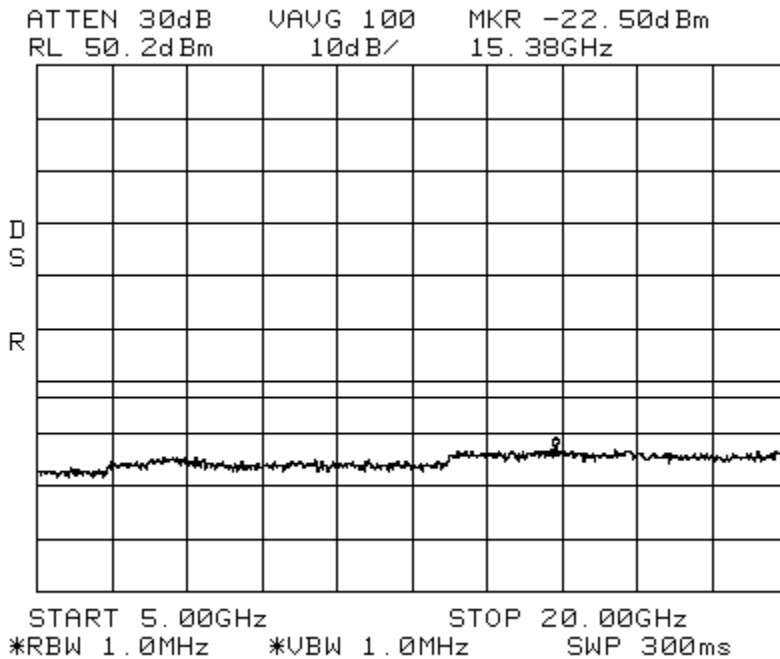

Intermodulation LTE 3 MHz Channel Bandwidth\_Low PCS 20W  
Center: 1962.5 MHz Span: 90 MHz RBW/VBW: 100 kHz

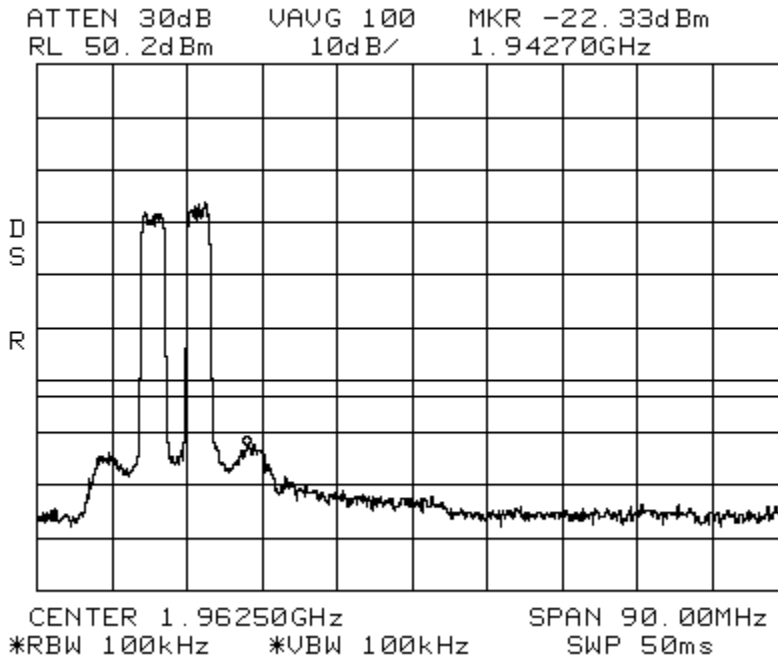

Intermodulation LTE 3MHz Channel Bandwidth\_LowPCS 20W  
Span: 30 MHz to 1 GHz RBW/VBW: 300 kHz

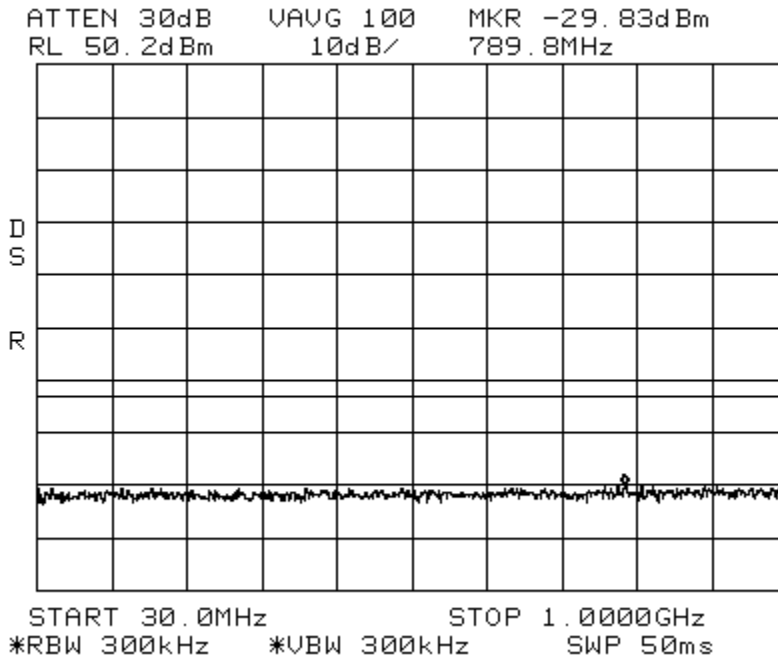

Intermodulation LTE 3 MHz Channel Bandwidth\_Low PCS 20W  
Span: 1 GHz to 5 GHz RBW/VBW: 1 MHz

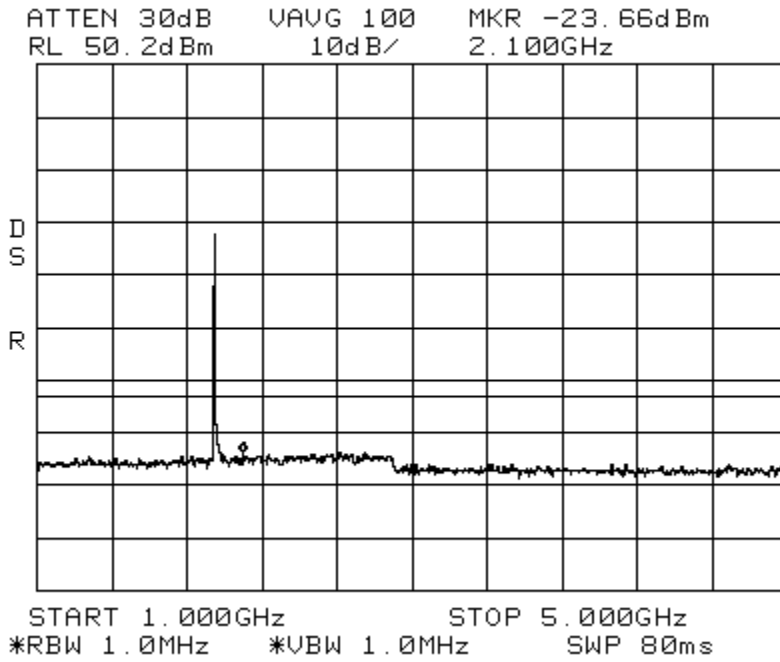

Intermodulation LTE 3 MHz Channel Bandwidth\_Low PCS 20W  
Span: 1 GHz to 5 GHz RBW/VBW: 1 MHz

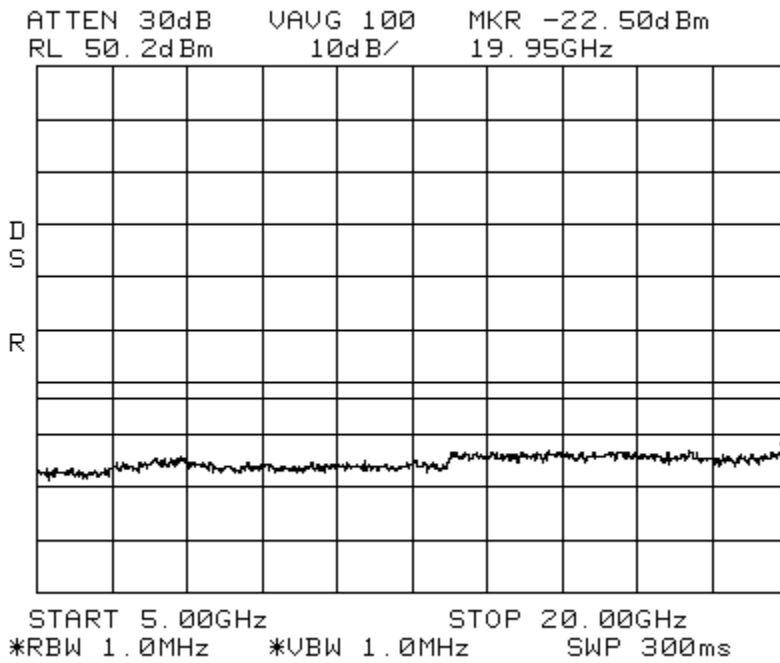

Intermodulation LTE 3 MHz Channel Bandwidth\_High PCS 20W  
Center: 1962.5 MHz Span: 90 MHz RBW/VBW: 100 kHz

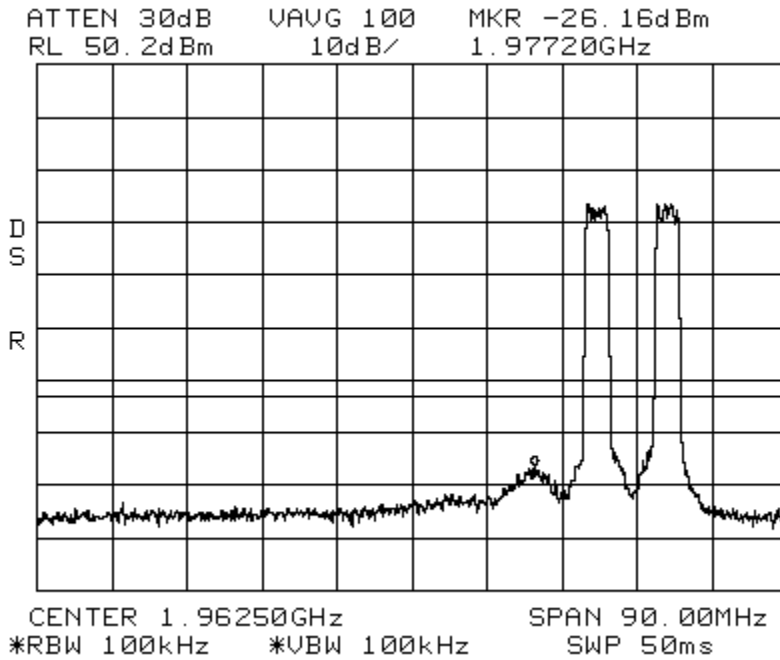

Intermodulation LTE 3 MHz Channel Bandwidth\_High PCS 20W  
Span: 30 MHz to 1 GHz RBW/VBW: 300 kHz

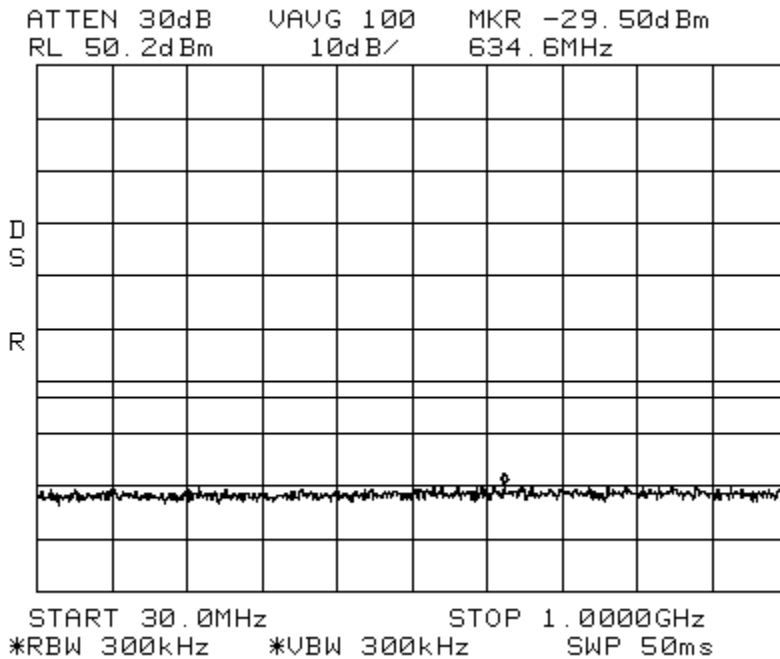

Intermodulation      LTE 3 MHz Channel Bandwidth\_High      PCS 20W  
Span: 1 GHz to 5 GHz      RBW/VBW: 1 MHz

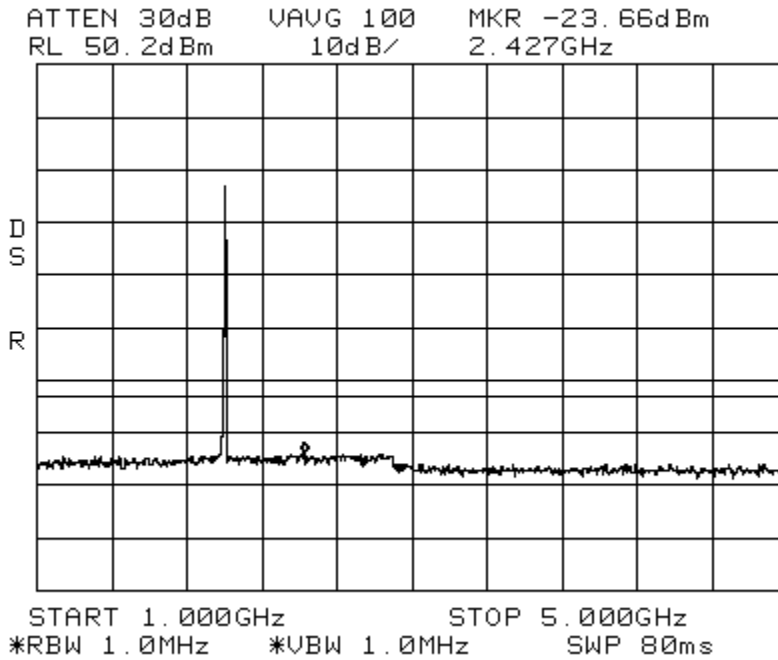

Intermodulation      LTE 3 MHz Channel Bandwidth\_High      PCS 20W  
Span: 1 GHz to 5 GHz      RBW/VBW: 1 MHz

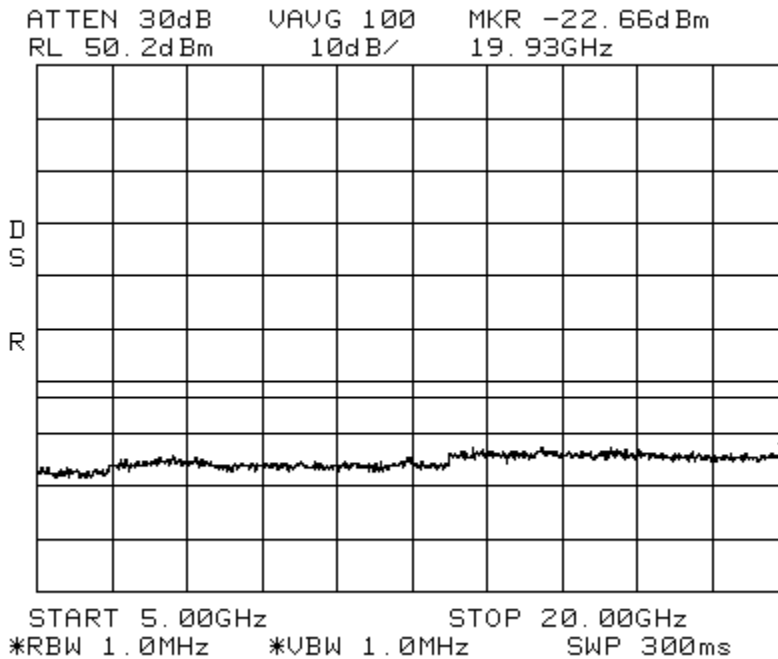

Intermodulation      LTE 3 MHz Channel Bandwidth \_Apart      PCS 20W  
Center: 1962.5 MHz      Span: 175 MHz      RBW/VBW: 100 kHz

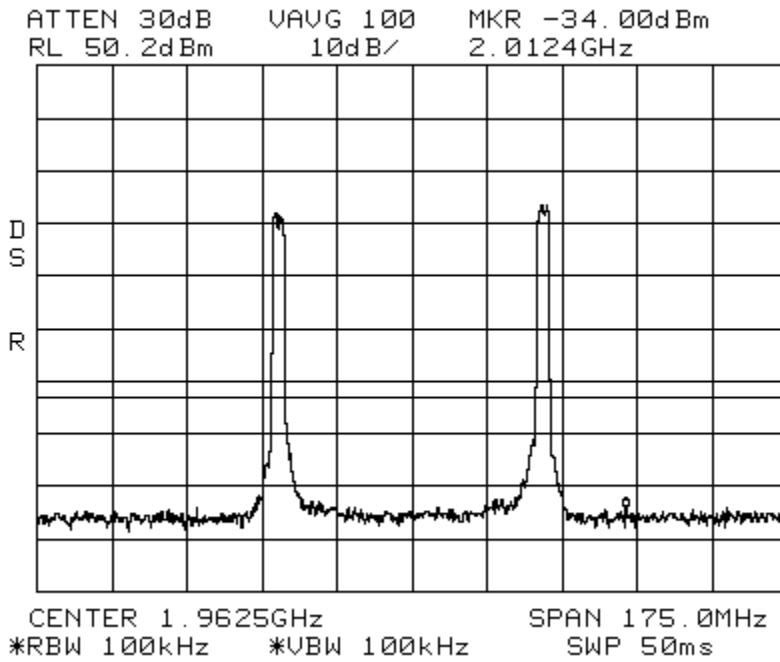

Intermodulation      LTE 3 MHz Channel Bandwidth \_Apart      PCS 20W  
Span: 30 MHz to 1 GHz      RBW/VBW: 300 kHz

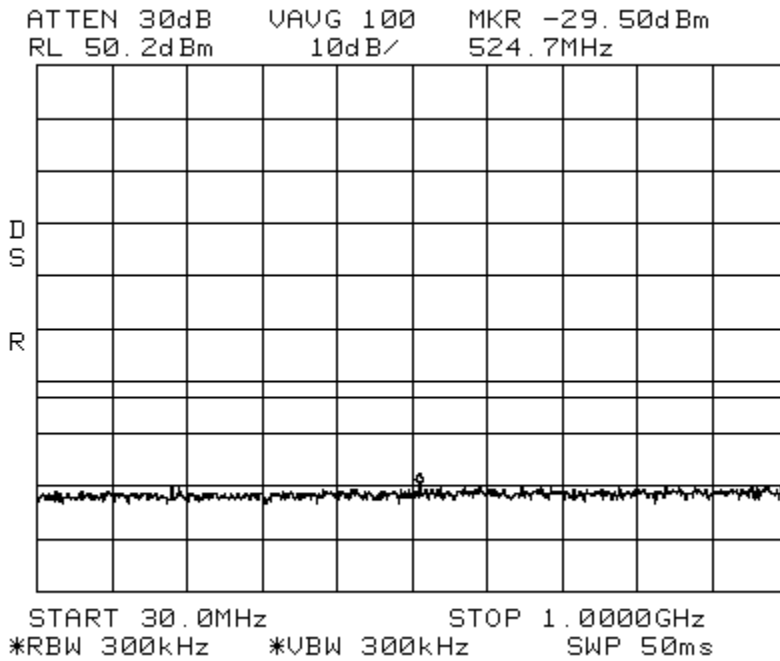



Intermodulation LTE 3 MHz Channel Bandwidth\_Apart PCS 20W  
Span: 1 GHz to 5 GHz RBW/VBW: 1 MHz

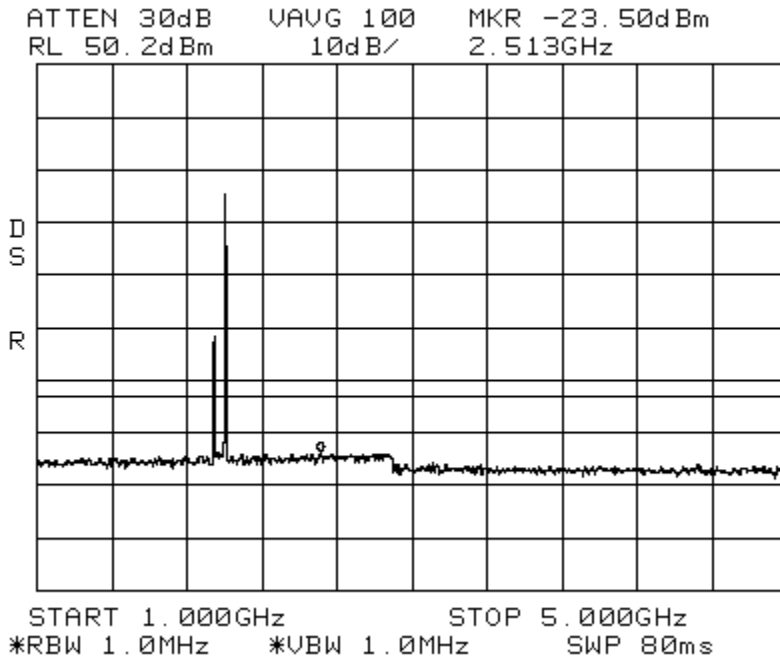

Intermodulation LTE 3 MHz Channel Bandwidth\_Apart PCS 20W  
Span: 5 GHz to 20 GHz RBW/VBW: 1 MHz

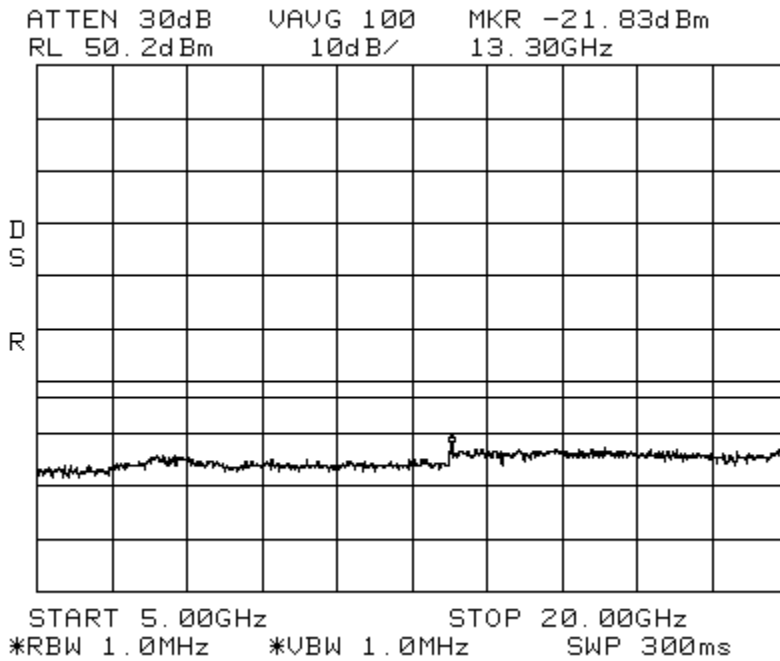

Intermodulation LTE 5 MHz Channel Bandwidth\_Low PCS 20W  
Center: 1962.5 MHz Span: 90 MHz RBW/VBW: 100 kHz

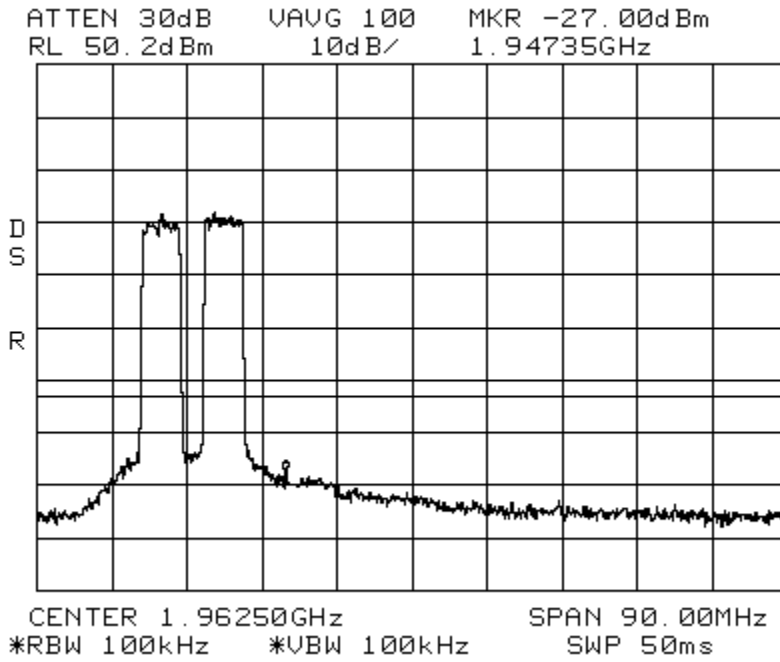

Intermodulation LTE 5 MHz Channel Bandwidth\_Low PCS 20W  
Span: 30 MHz to 1 GHz RBW/VBW: 300 kHz

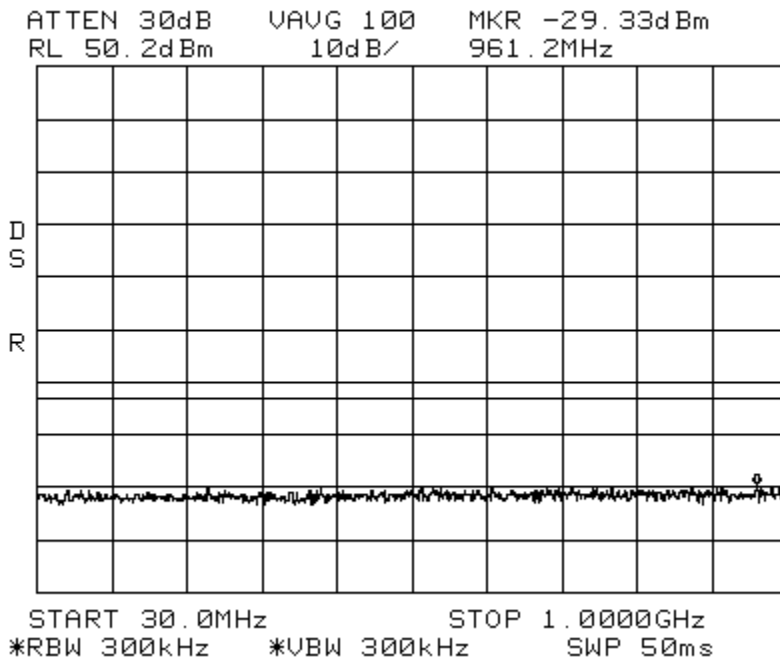

Intermodulation      LTE 5 MHz Channel Bandwidth\_Low      PCS 20W  
Span: 1 GHz to 5 GHz      RBW/VBW: 1 MHz

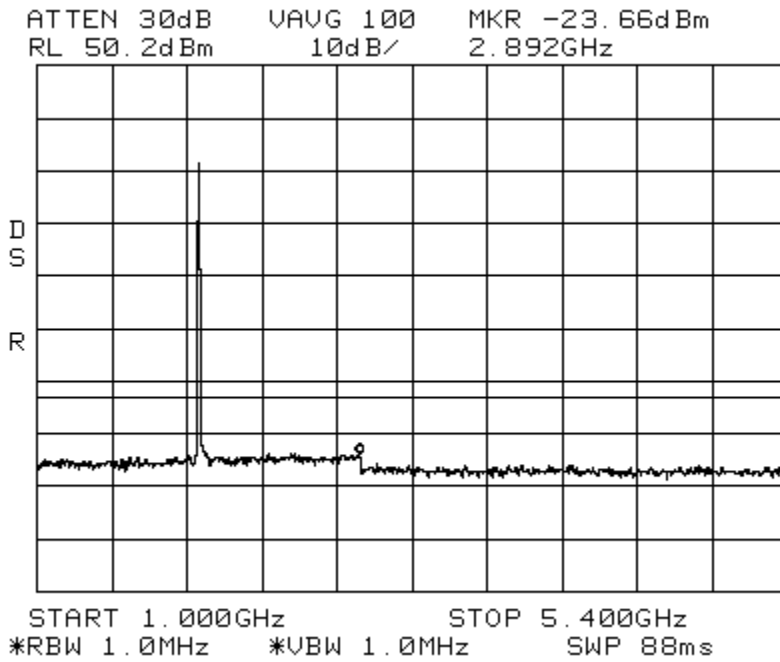

Intermodulation      LTE 5 MHz Channel Bandwidth\_Low      PCS 20W  
Span: 5 GHz to 20 GHz      RBW/VBW: 1 MHz

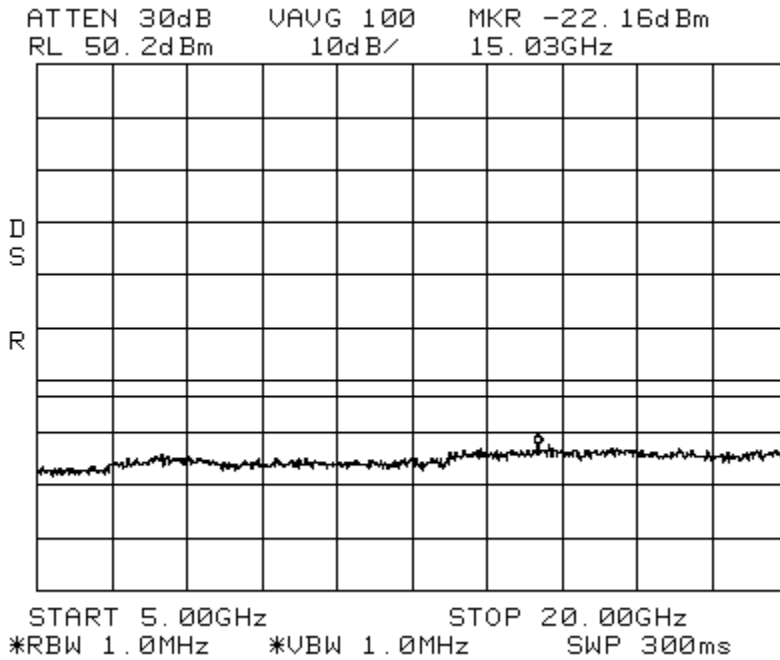

Intermodulation LTE 5 MHz Channel Bandwidth\_High PCS 20W  
Center: 1962.5 MHz Span: 90 MHz RBW/VBW: 100 kHz

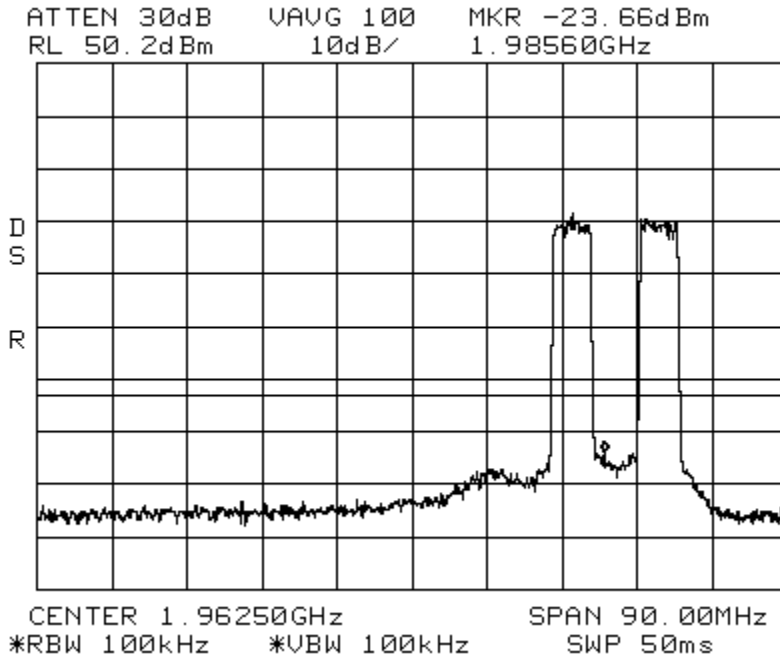

Intermodulation LTE 5 MHz Channel Bandwidth\_High PCS 20W  
Span: 30 MHz to 1 GHz RBW/VBW: 300 kHz

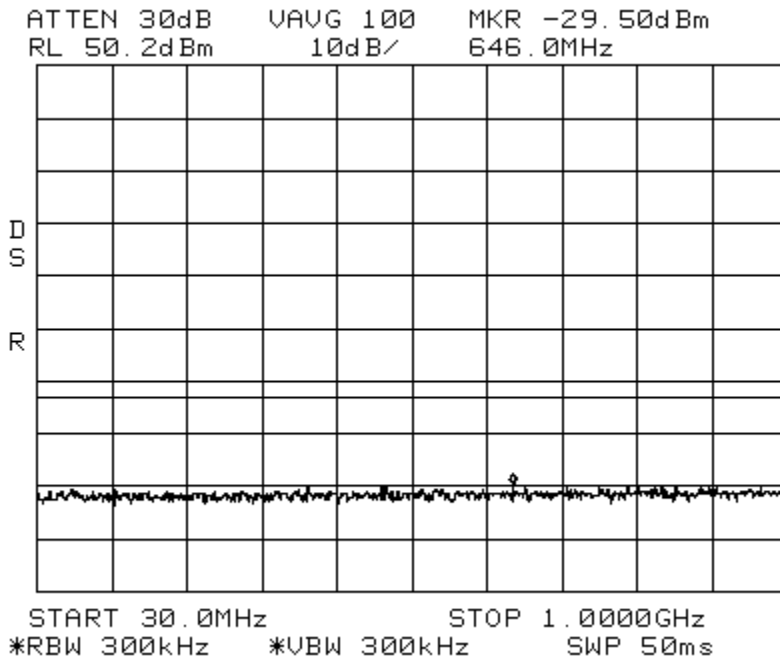

Intermodulation LTE 5 MHz Channel Bandwidth\_High PCS 20W  
Span: 1 GHz to 5 GHz RBW/VBW: 1 MHz

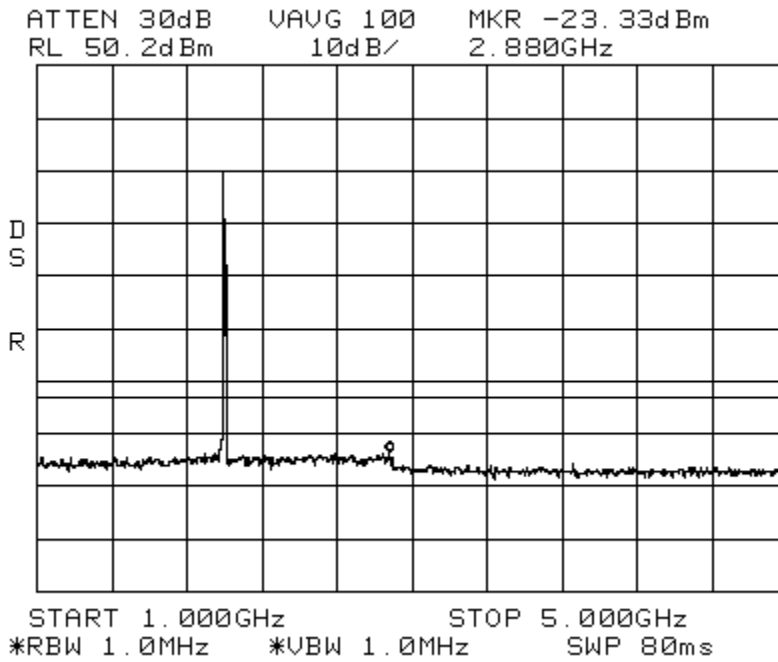

Intermodulation LTE 5 MHz Channel Bandwidth\_High PCS 20W  
Span: 5 GHz to 20 GHz RBW/VBW: 1 MHz

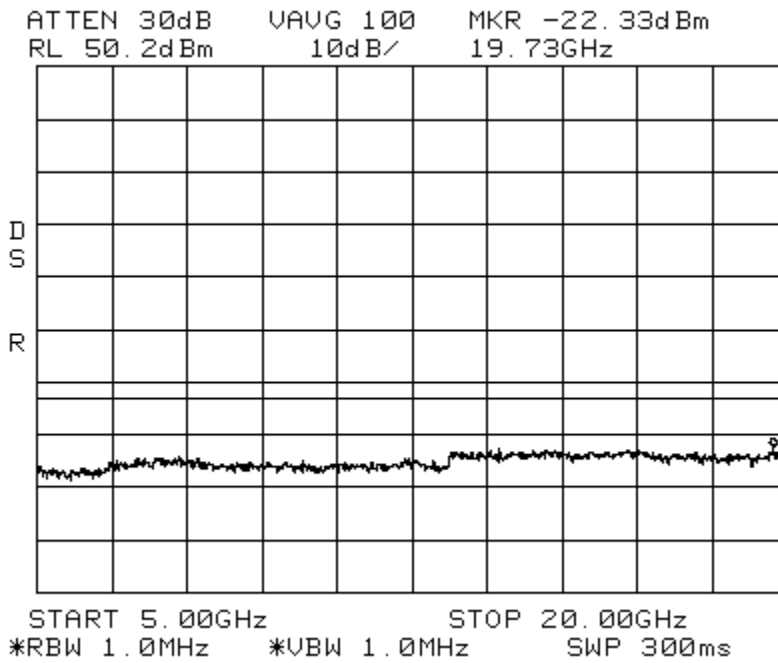

Intermodulation      LTE 5 MHz Channel Bandwidth \_Apart      PCS 20W  
Center: 1962.5 MHz      Span: 175 MHz      RBW/VBW: 100 kHz

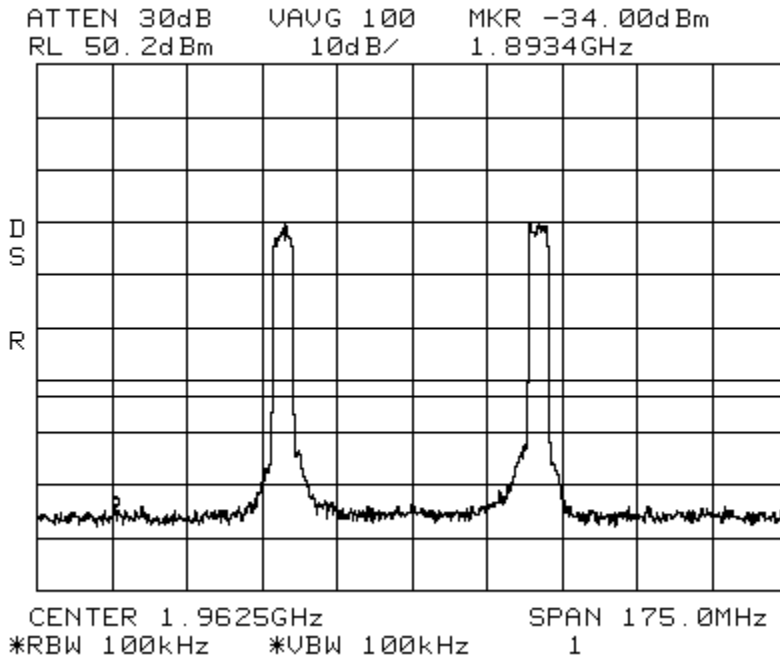

Intermodulation      LTE 5 MHz Channel Bandwidth \_Apart      PCS 20W  
Span: 30 MHz to 1 GHz      RBW/VBW: 300 kHz

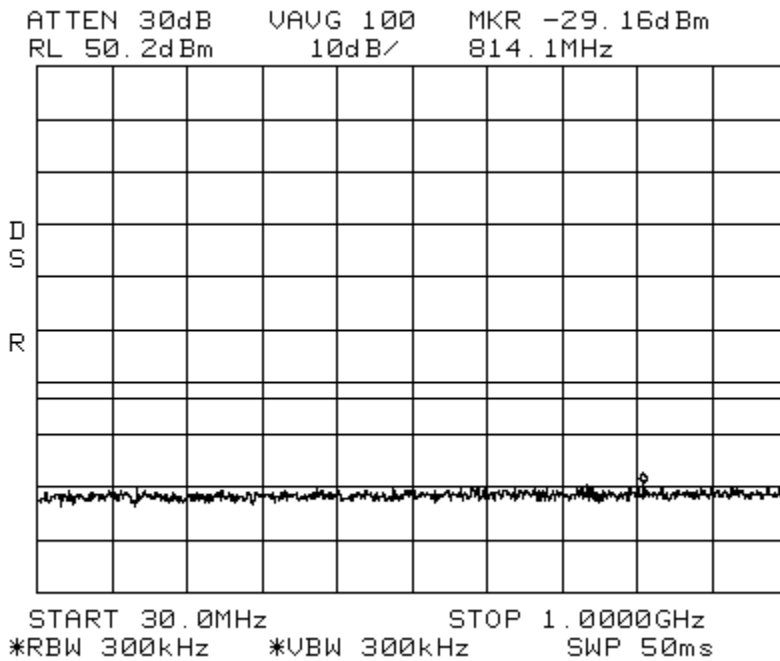

Intermodulation LTE 5 MHz Channel Bandwidth \_Apart PCS 20W  
Span: 1 GHz to 5 GHz RBW/VBW: 1 MHz

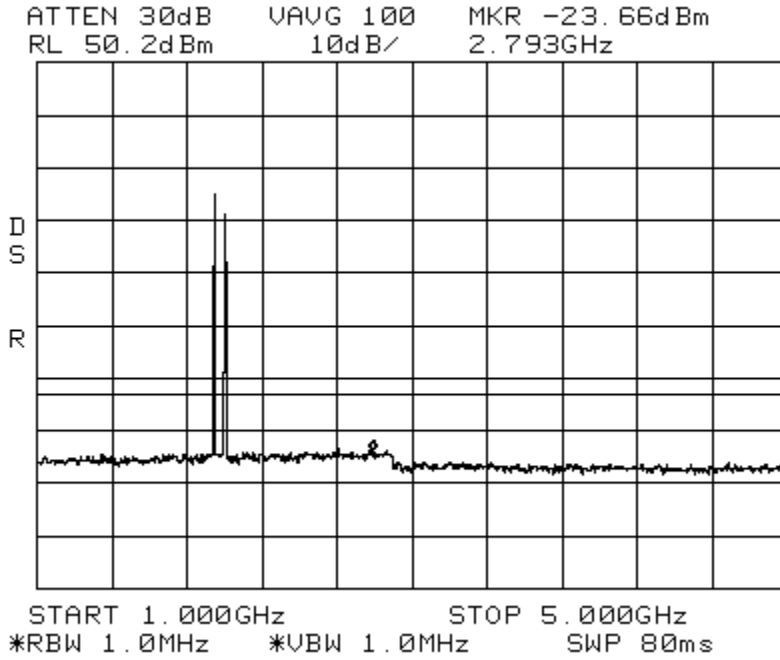

Intermodulation LTE 5 MHz Channel Bandwidth \_Apart PCS 20W  
Span: 5 GHz to 20 GHz RBW/VBW: 1 MHz

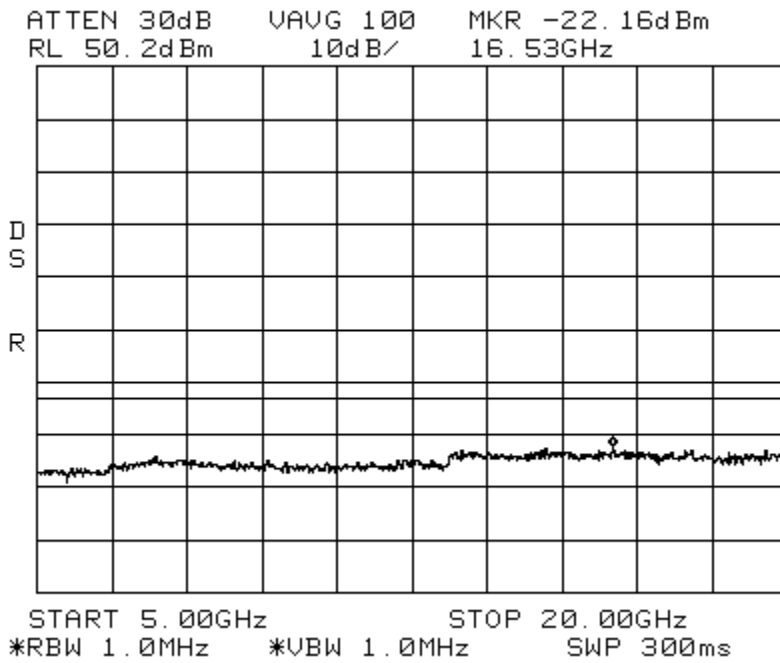

Intermodulation LTE 10 MHz Channel Bandwidth\_Low PCS 20W  
Center: 1962.5 MHz Span: 90 MHz RBW/VBW: 100 kHz

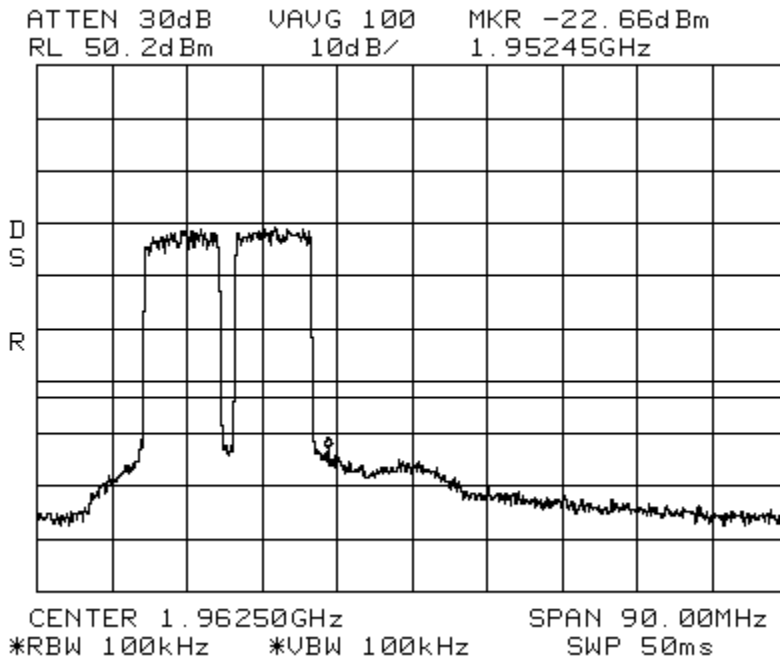

Intermodulation LTE 10 MHz Channel Bandwidth\_Low PCS 20W  
Span: 30 MHz to 1 GHz RBW/VBW: 300 kHz

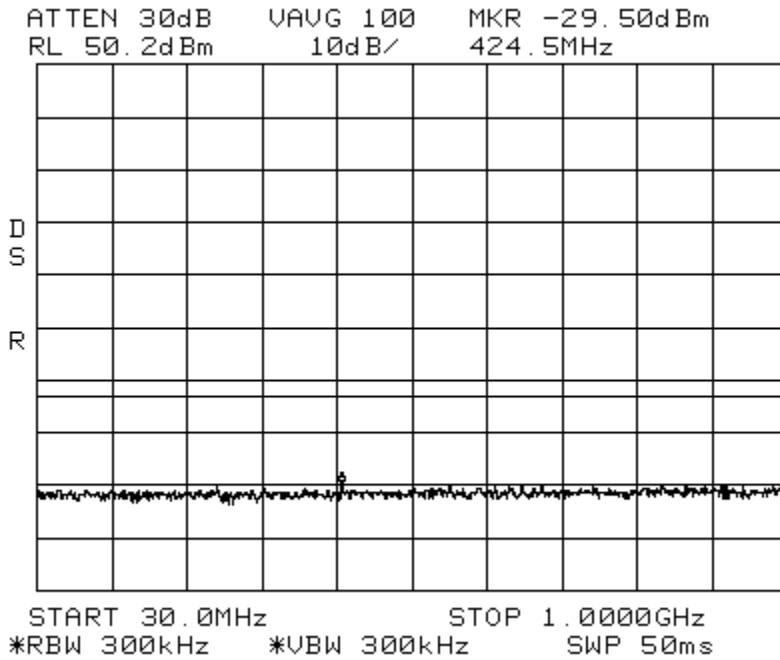



Intermodulation LTE 10 MHz Channel Bandwidth\_Low  
Span: 1 GHz to 5GHz RBW/VBW: 1 MHz

PCS 20W

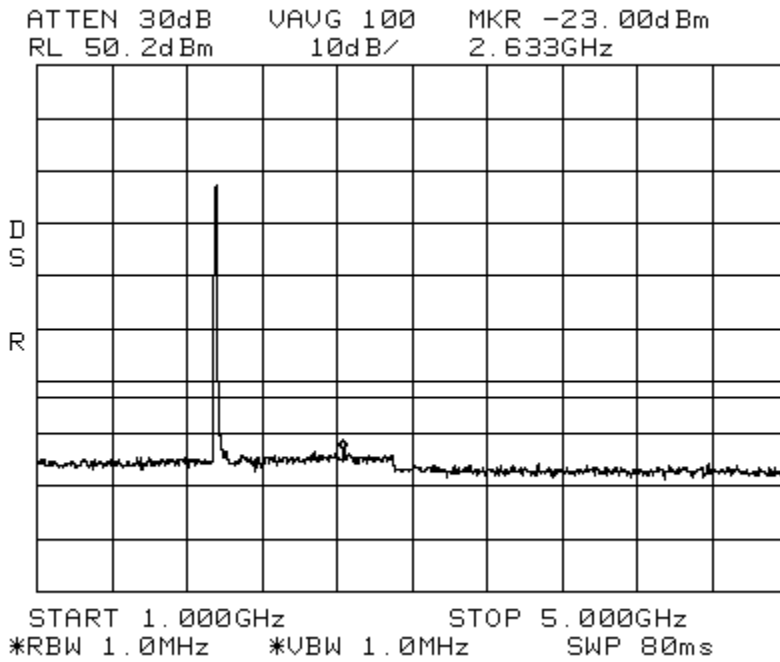

Intermodulation LTE 10 MHz Channel Bandwidth\_Low  
Span: 5 GHz to 20 GHz RBW/VBW: 1 MHz

PCS 20W

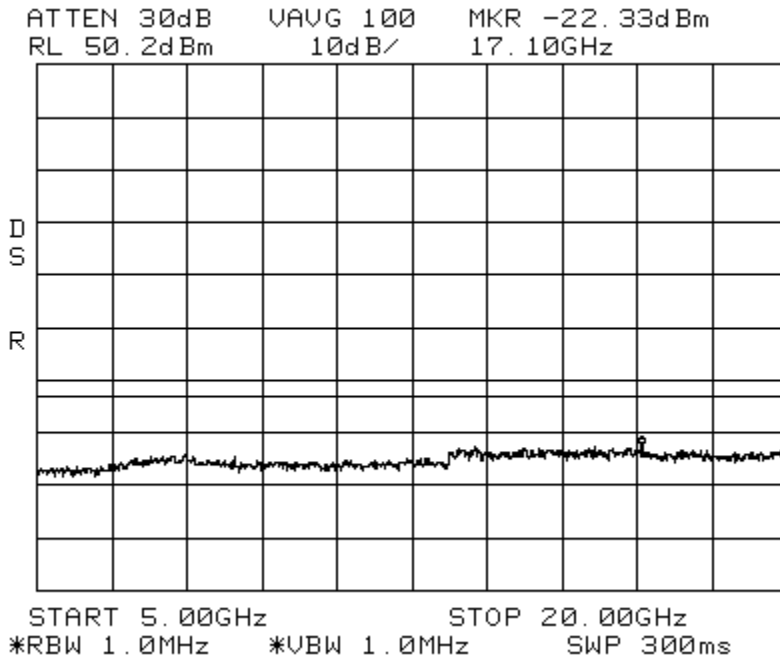

Intermodulation LTE 10 MHz Channel Bandwidth\_High PCS 20W  
Center: 1962.5 MHz Span: 90 MHz RBW/VBW: 100 kHz

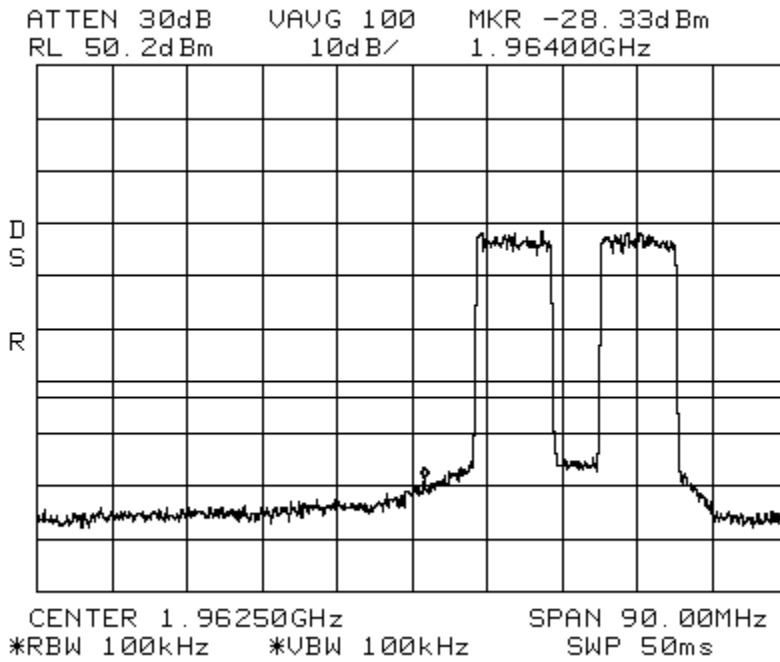

Intermodulation LTE 10 MHz Channel Bandwidth\_High PCS 20W  
Span: 30 MHz to 1 GHz RBW/VBW: 300 kHz

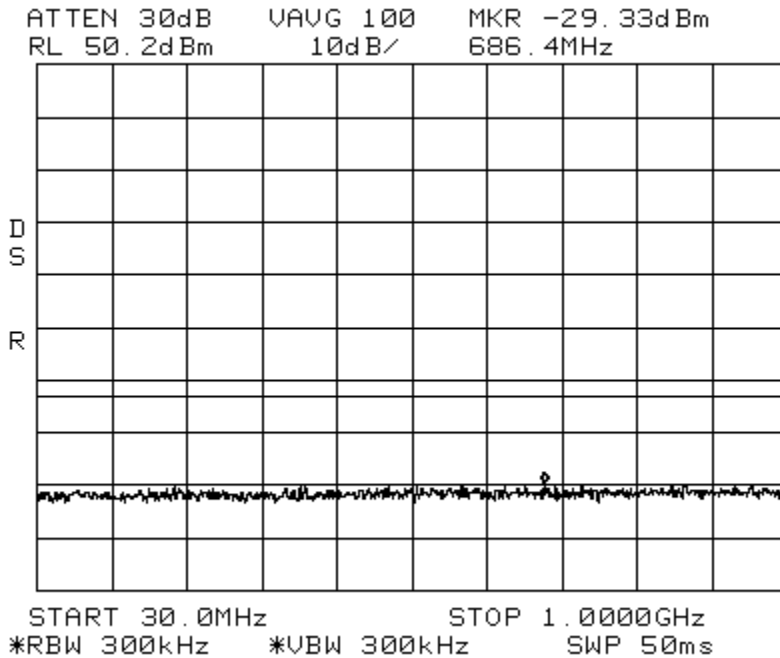

Intermodulation LTE 10 MHz Channel Bandwidth\_High PCS 20W  
Span: 1 GHz to 5 GHz RBW/VBW: 1 MHz

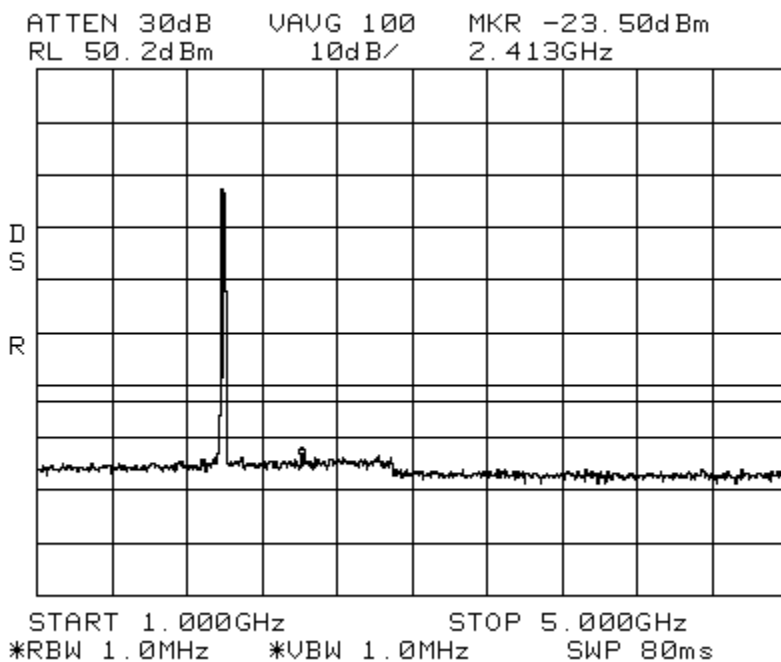

Intermodulation LTE 10 MHz Channel Bandwidth\_High PCS 20W  
Span: 5 GHz to 20 GHz RBW/VBW: 1 MHz

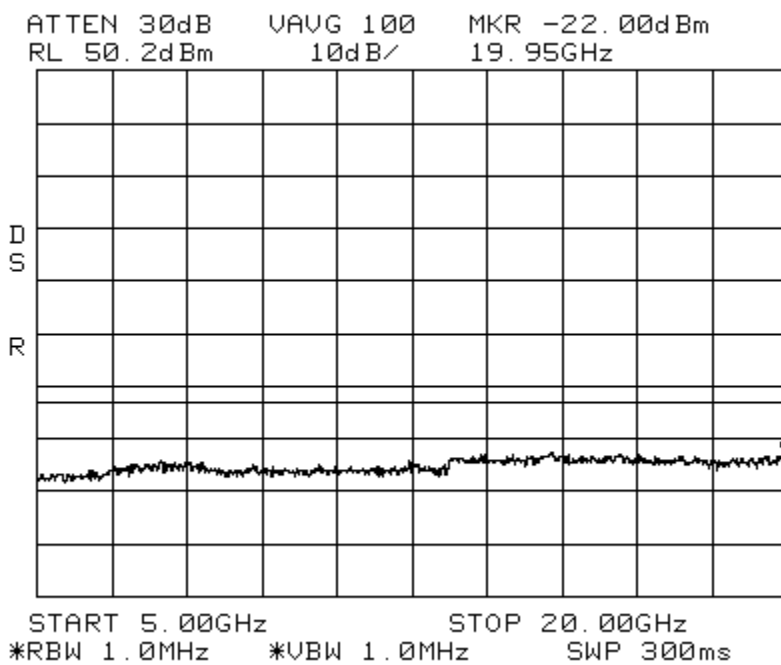

Intermodulation      LTE 10 MHz Channel Bandwidth \_Apart      PCS 20W  
Center: 1962.5 MHz      Span: 175 MHz      RBW/VBW: 100 kHz

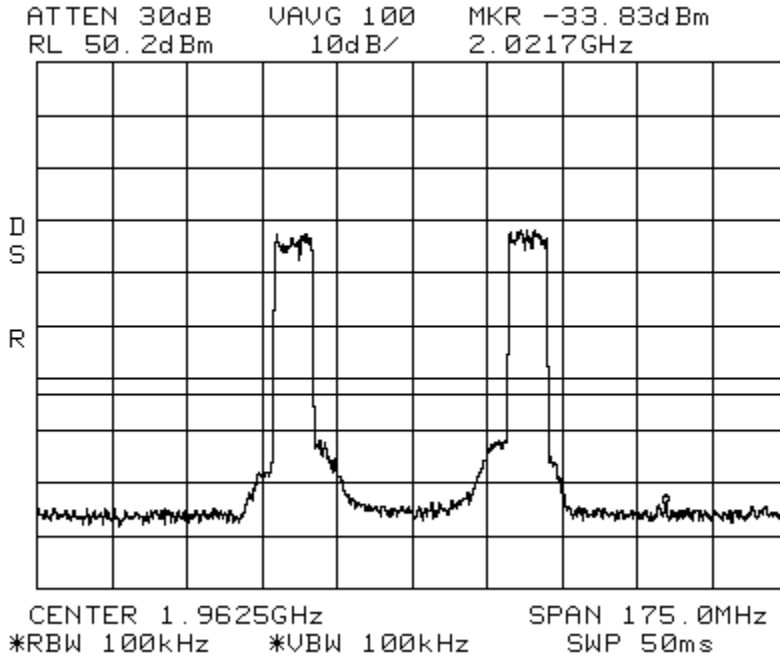

Intermodulation      LTE 10 MHz Channel Bandwidth \_Apart      PCS 20W  
Span: 30 MHz to 1 GHz      RBW/VBW: 300 kHz

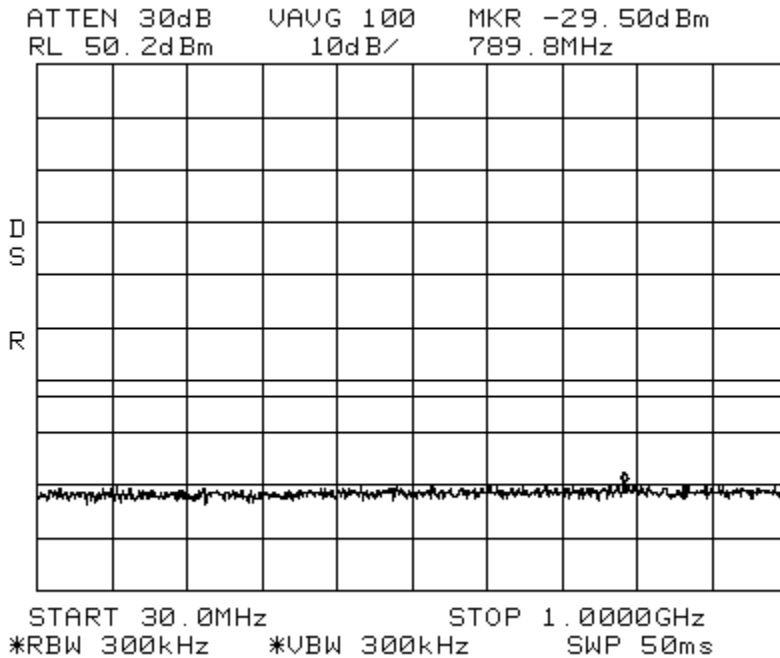

Intermodulation LTE 10 MHz Channel Bandwidth \_Apart PCS 20W  
Span: 1 GHz to 5 GHz RBW/VBW: 1 MHz

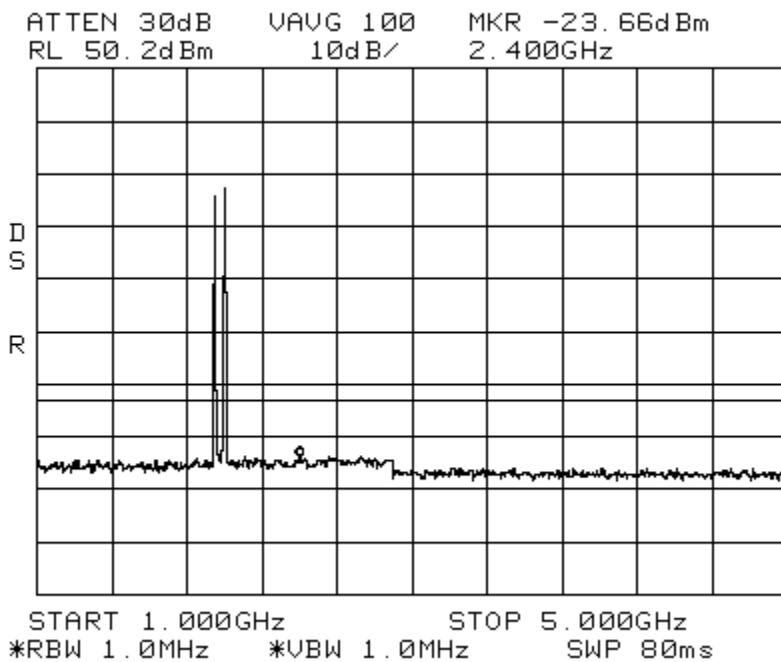

Intermodulation LTE 10 MHz Channel Bandwidth \_Apart PCS 20W  
Span: 5 GHz to 20 GHz RBW/VBW: 1 MHz

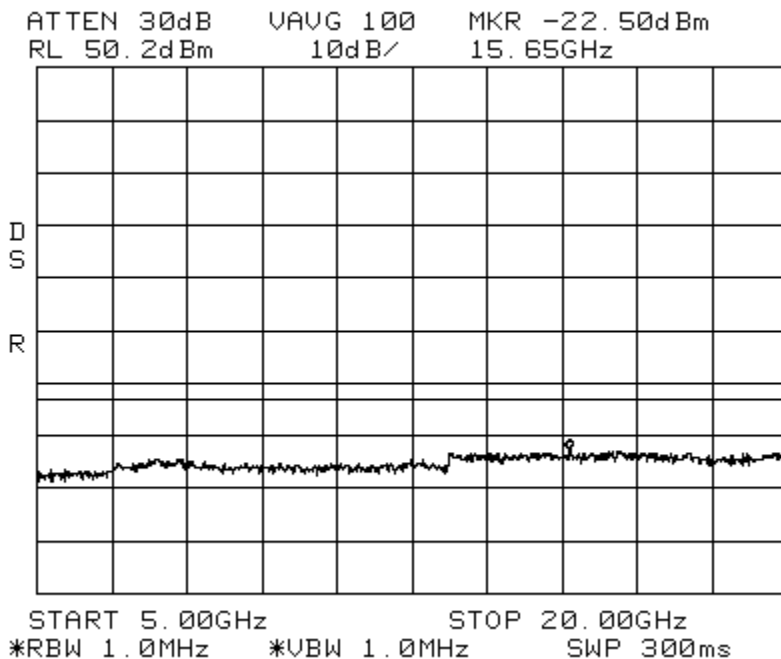

Intermodulation LTE 15 MHz Channel Bandwidth\_Low PCS 20W  
Center: 1962.5 MHz Span: 90 MHz RBW/VBW: 100 kHz

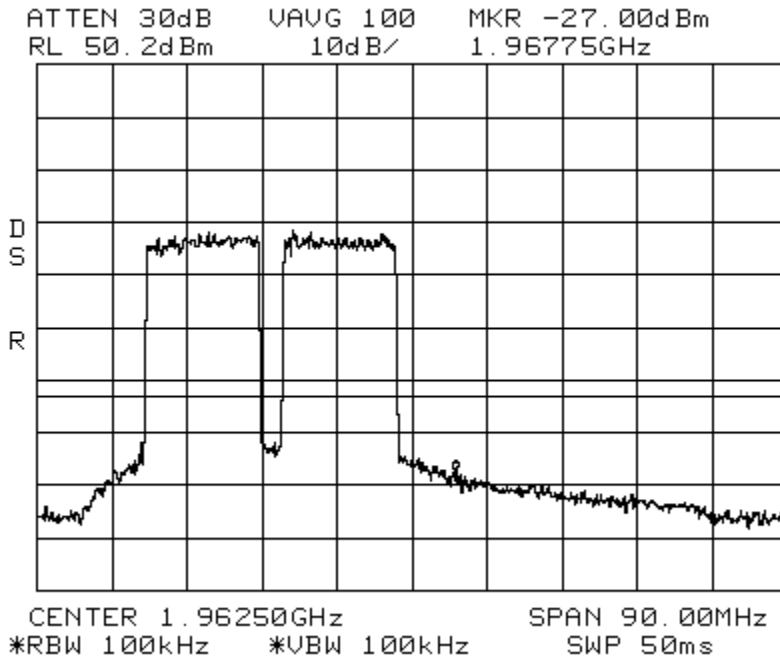

Intermodulation LTE 15 MHz Channel Bandwidth\_Low PCS 20W  
Span: 30 MHz to 1 GHz RBW/VBW: 300 kHz

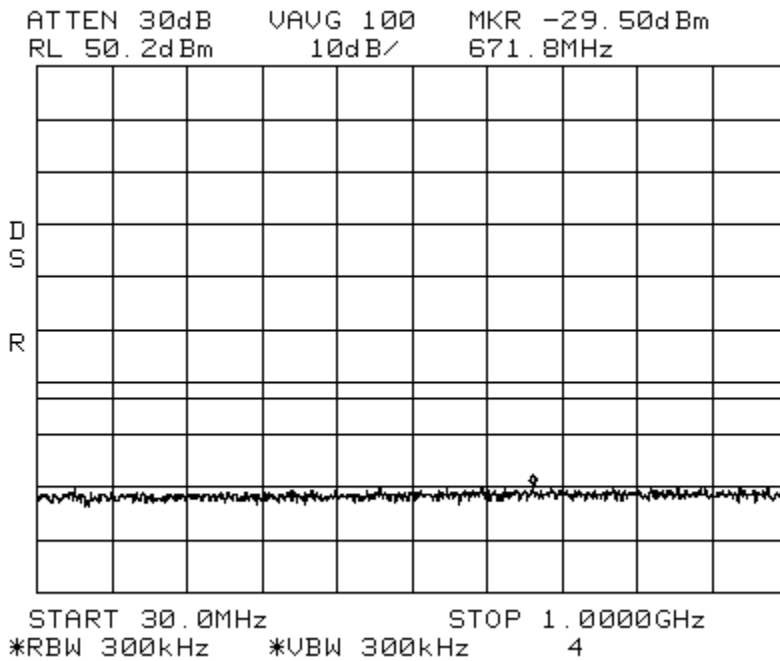

Intermodulation      LTE 15 MHz Channel Bandwidth \_Low      PCS 20W  
Span: 1 GHz to 5 GHz      RBW/VBW: 1 MHz

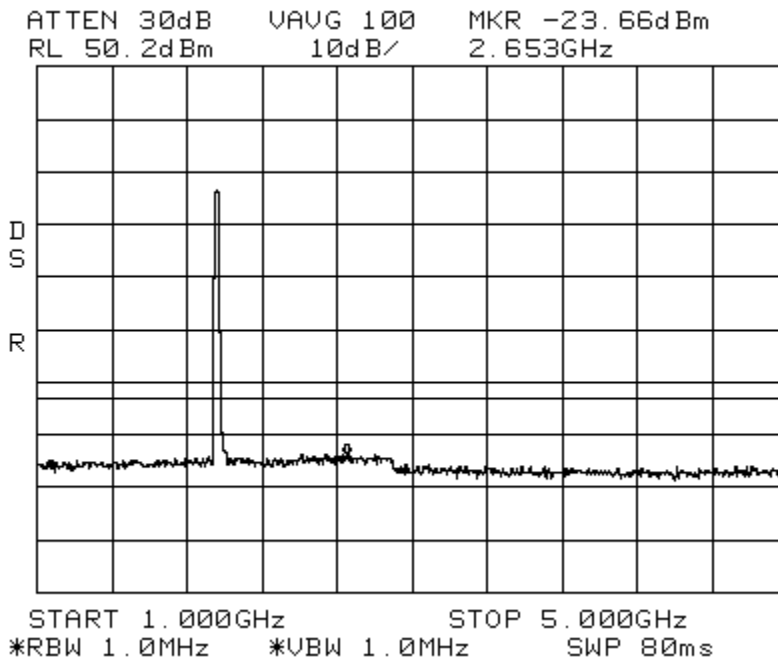

Intermodulation      LTE 15 MHz Channel Bandwidth \_Low      PCS 20W  
Span: 5 GHz to 20GHz      RBW/VBW: 1 MHz

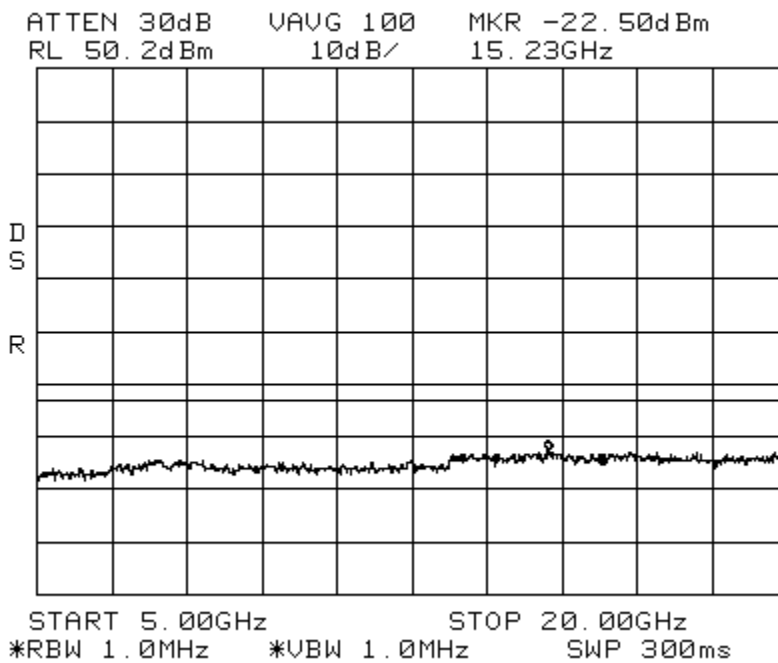

Intermodulation LTE 15 MHz Channel Bandwidth\_High PCS 20W  
Center: 1962.5 MHz Span: 90 MHz RBW/VBW: 100 kHz

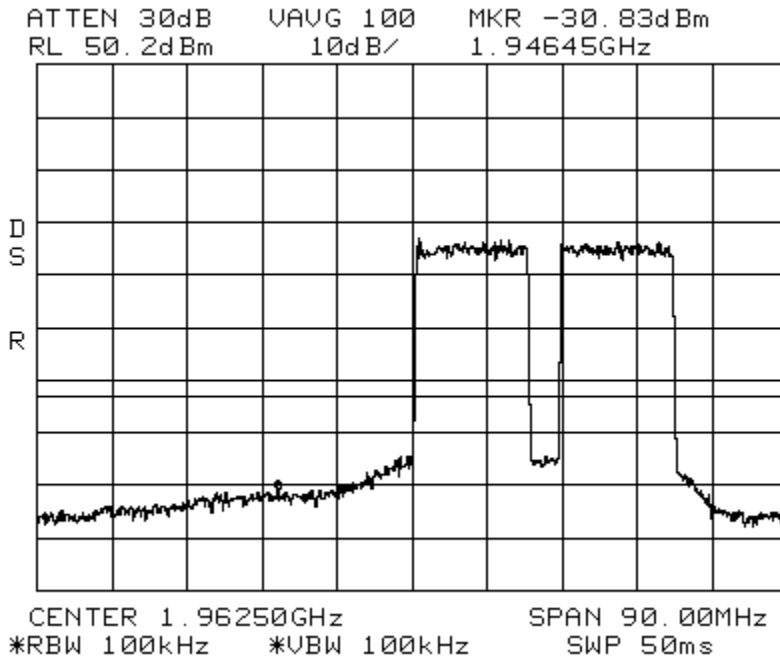

Intermodulation LTE 15 MHz Channel Bandwidth\_High PCS 20W  
Span: 30 MHz to 1 GHz RBW/VBW: 300 kHz

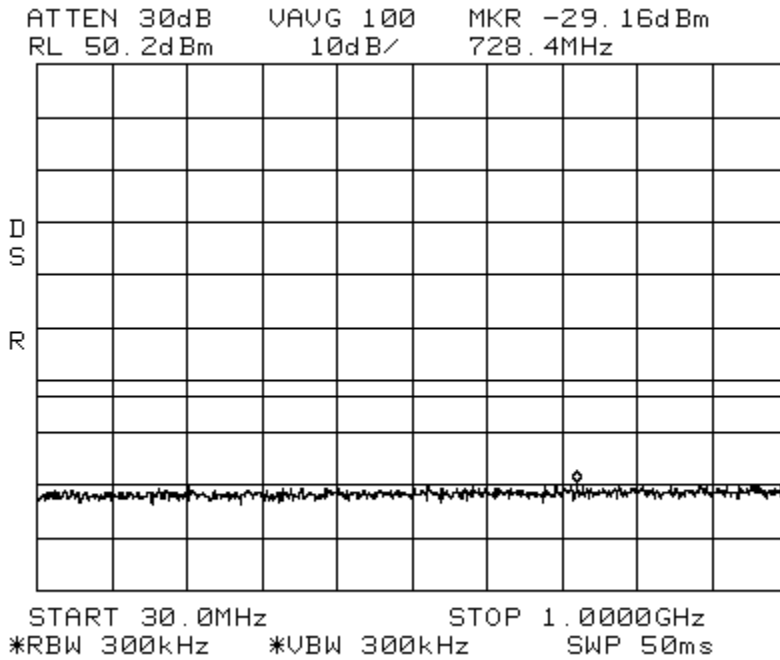



Intermodulation LTE 15 MHz Channel Bandwidth\_High PCS 20W  
Span: 1 GHz to 5 GHz RBW/VBW: 1 MHz

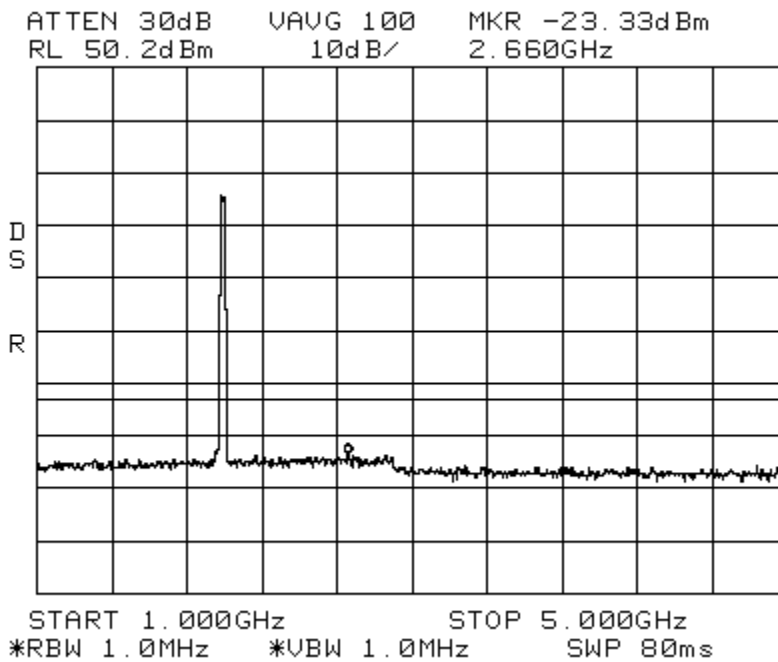

Intermodulation LTE 15 MHz Channel Bandwidth\_High PCS 20W  
Span: 5 GHz to 20 GHz RBW/VBW: 1 MHz

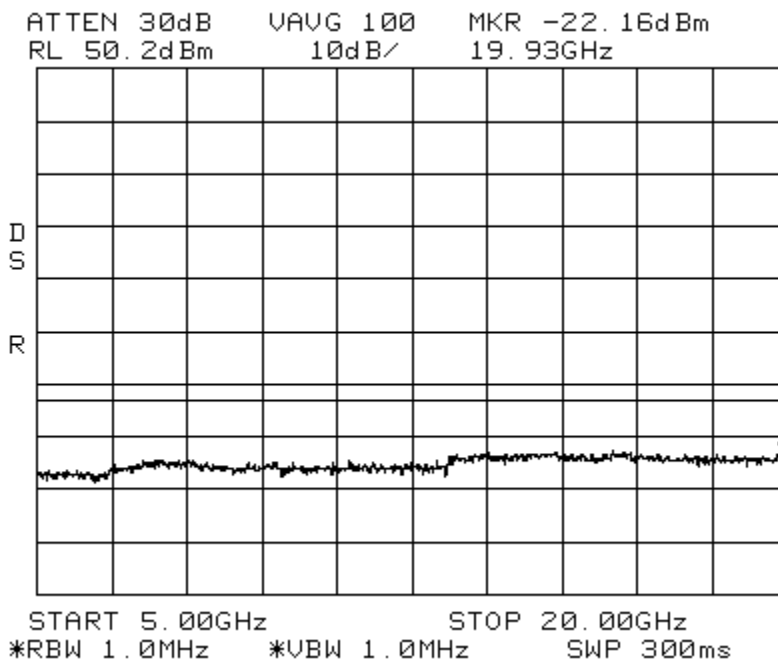

Intermodulation LTE 15 MHz Channel Bandwidth \_Apart PCS 20W  
Center: 1962.5 MHz Span: 90 MHz RBW/VBW: 100 kHz

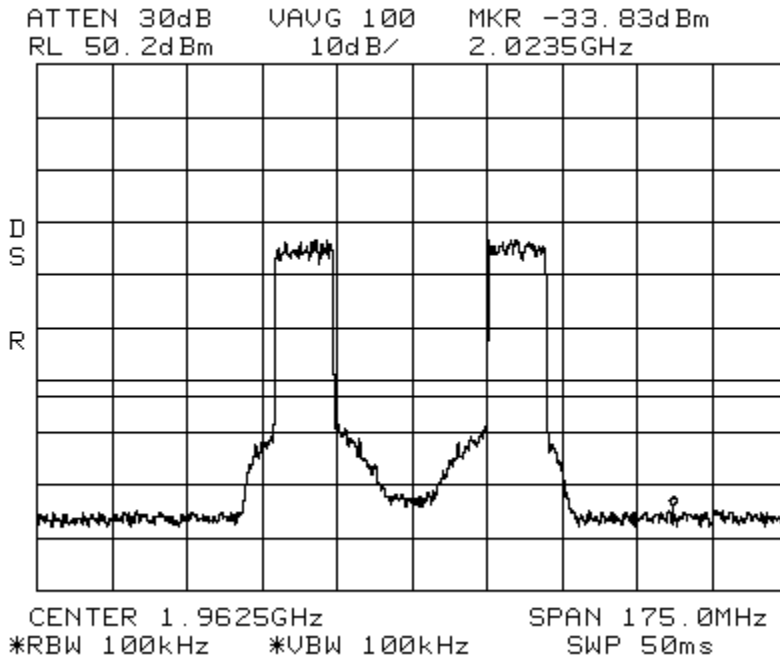

Intermodulation LTE 15 MHz Channel Bandwidth \_Apart PCS 20W  
Span: 30 MHz to 1 GHz RBW/VBW: 300 kHz

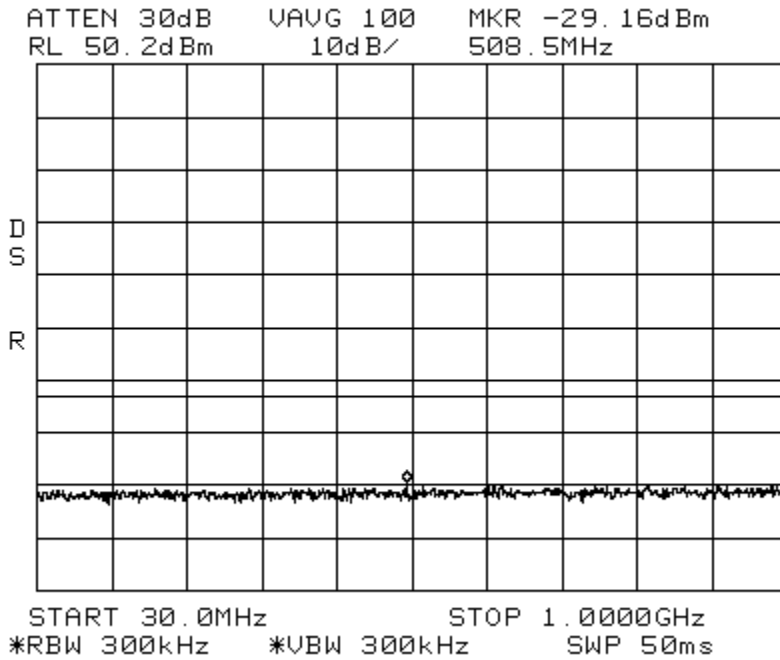

Intermodulation LTE 15 MHz Channel Bandwidth \_Apart PCS 20W  
Span: 1 GHz to 5 GHz RBW/VBW: 1 MHz

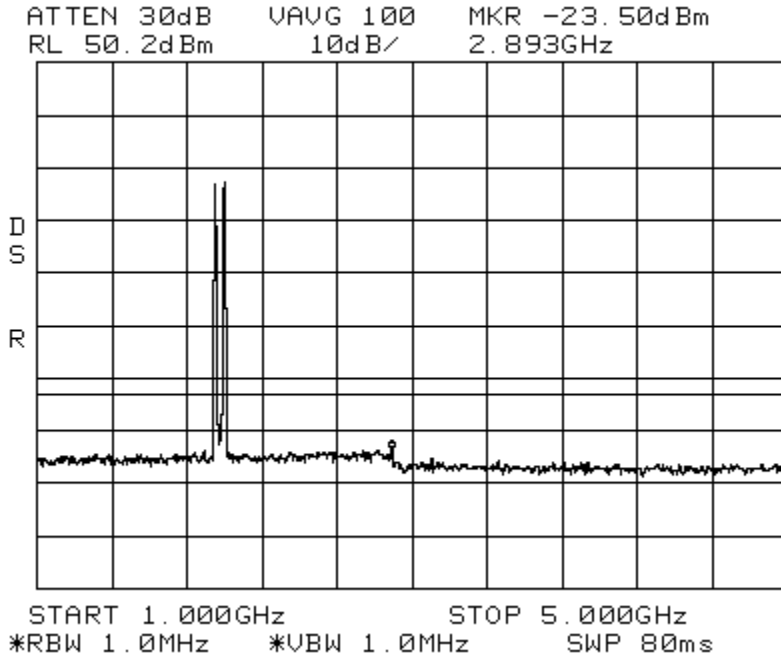

Intermodulation LTE 15 MHz Channel Bandwidth \_Apart PCS 20W  
Span: 1 GHz to 20 GHz RBW/VBW: 1 MHz

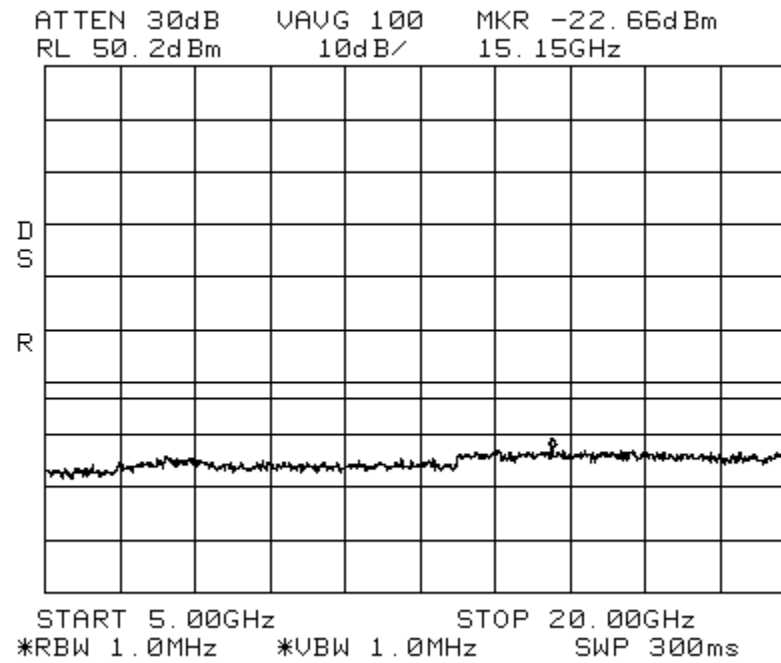

Intermodulation  
Center: 1962.5 MHz

WCDMA\_Low  
Span: 90 MHz

PCS 20W  
RBW/VBW: 100 kHz

ATTEN 30dB    VAUG 100    MKR -25.00dBm  
RL 50.2dBm    10dB/    1.94735GHz

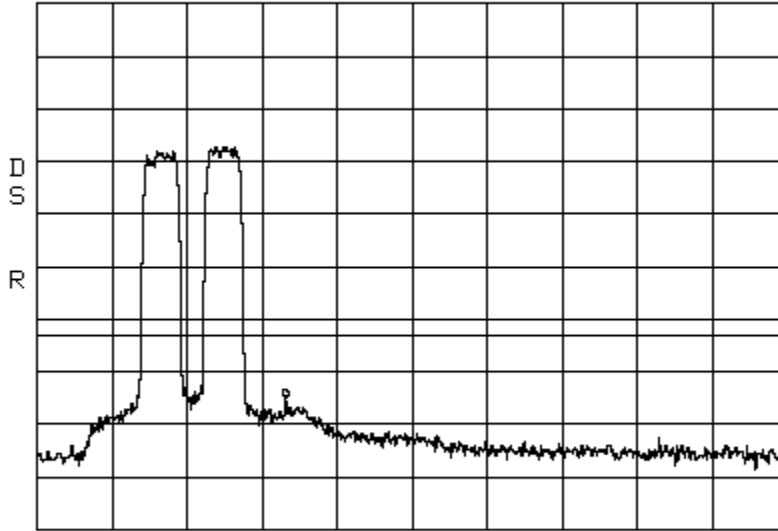

CENTER 1.96250GHz    SPAN 90.00MHz  
\*RBW 100kHz    \*VBW 1.0MHz    SWP 50ms

Intermodulation  
Span: 30 MHz to 1 GHz

WCDMA\_Low    PCS 20W  
RBW/VBW: 300 kHz

ATTEN 30dB    VAUG 100    MKR -29.66dBm  
RL 50.2dBm    10dB/    760.7MHz

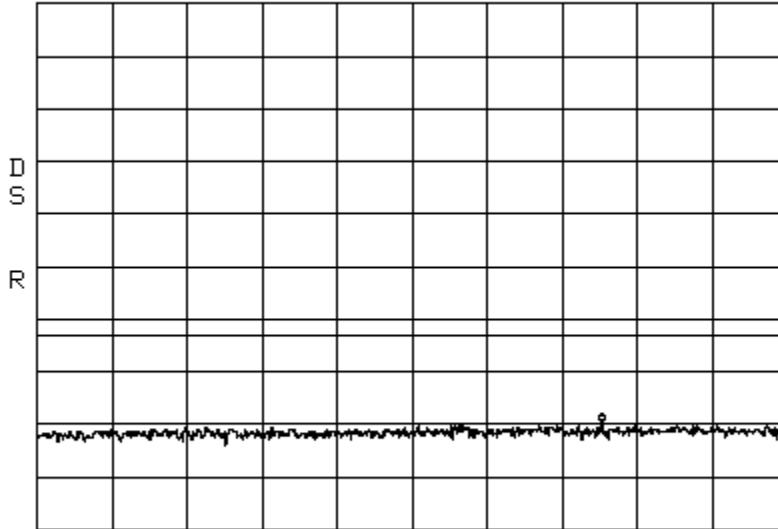

START 30.0MHz    STOP 1.0000GHz  
\*RBW 300kHz    \*VBW 300kHz    SWP 50ms

Intermodulation  
Span: 1 GHz to 5 GHz

WCDMA\_Low PCS 20W  
RBW/VBW: 1 MHz

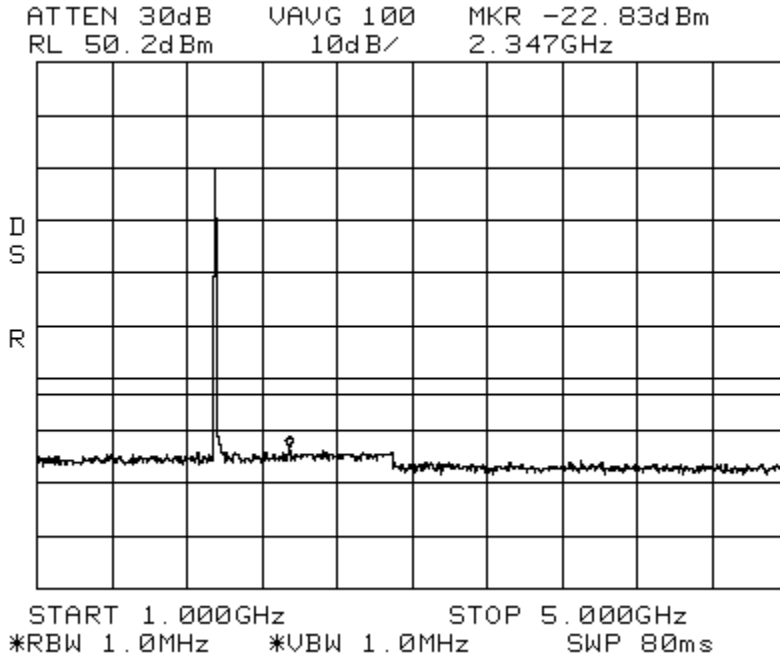

Intermodulation  
Span: 5 GHz to 20 GHz

WCDMA\_Low PCS 20W  
RBW/VBW: 1 MHz

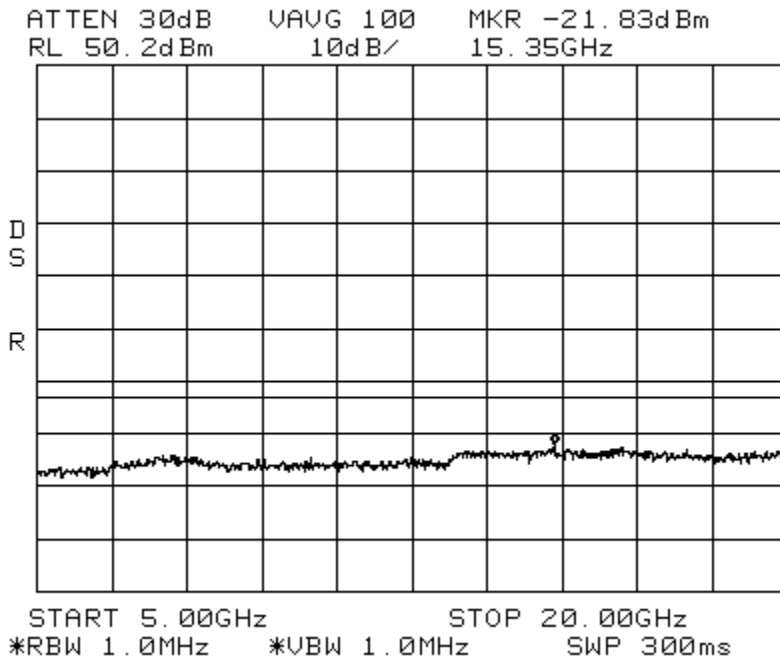

Intermodulation  
Center: 1962.5 MHz

WCDMA\_High  
Span: 90 MHz

PCS 20W  
RBW/VBW: 100 kHz

ATTEN 30dB    VAVG 100    MKR -26.50dBm  
RL 50.2dBm    10dB/    1.97960GHz

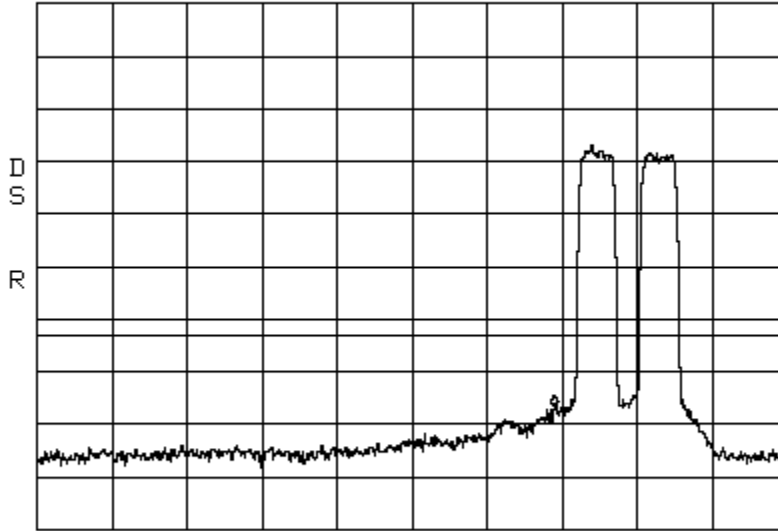

CENTER 1.96250GHz    SPAN 90.00MHz  
\*RBW 100kHz    \*VBW 100kHz    SWP 50ms

Intermodulation  
Span: 30 MHz to 1 GHz

WCDMA\_High    PCS 20W  
RBW/VBW: 300 kHz

ATTEN 30dB    VAVG 100    MKR -29.16dBm  
RL 50.2dBm    10dB/    914.3MHz

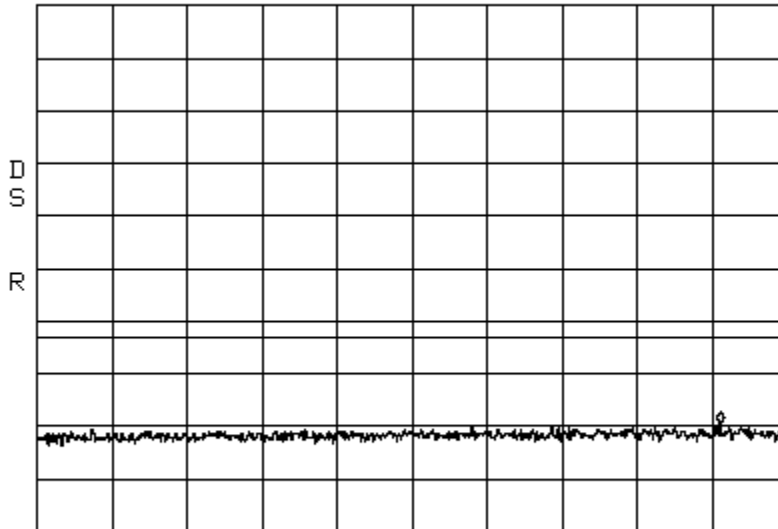

START 30.0MHz    STOP 1.0000GHz  
\*RBW 300kHz    \*VBW 300kHz    SWP 50ms

Intermodulation  
Span: 1 GHz to 5 GHz

WCDMA\_High PCS 20W  
RBW/VBW: 1 MHz

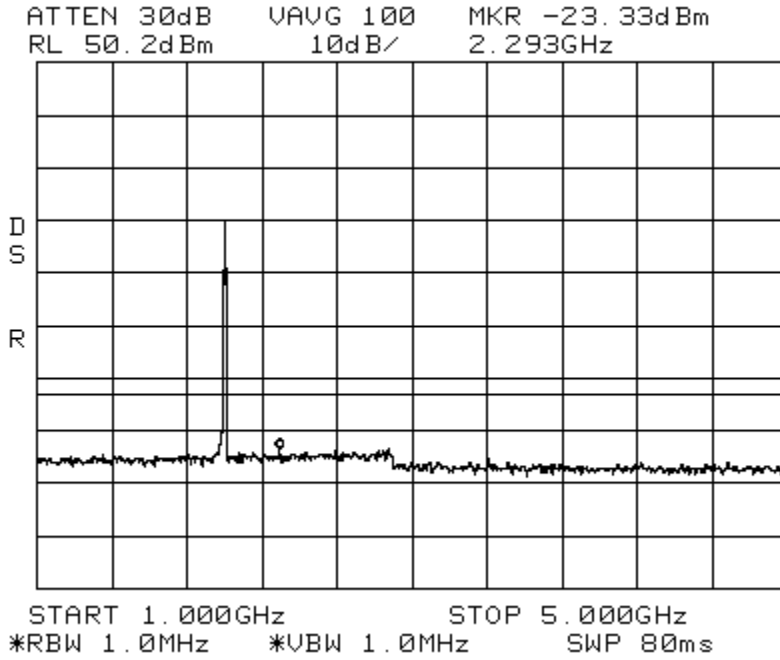

Intermodulation  
Span: 5 GHz to 20 GHz

WCDMA\_High PCS 20W  
RBW/VBW: 1 MHz

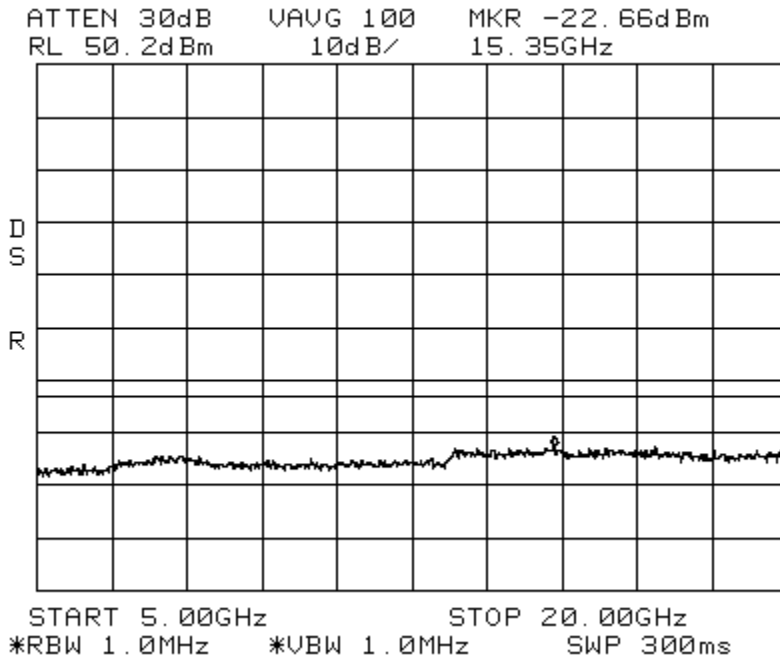

Intermodulation  
Center: 1962.5 MHz

WCDMA\_Apart  
Span: 175 MHz

PCS 20W  
RBW/VBW: 100 kHz

ATTEN 30dB    VAUG 100    MKR -32.83dBm  
RL 50.2dBm    10dB/    1.9631GHz

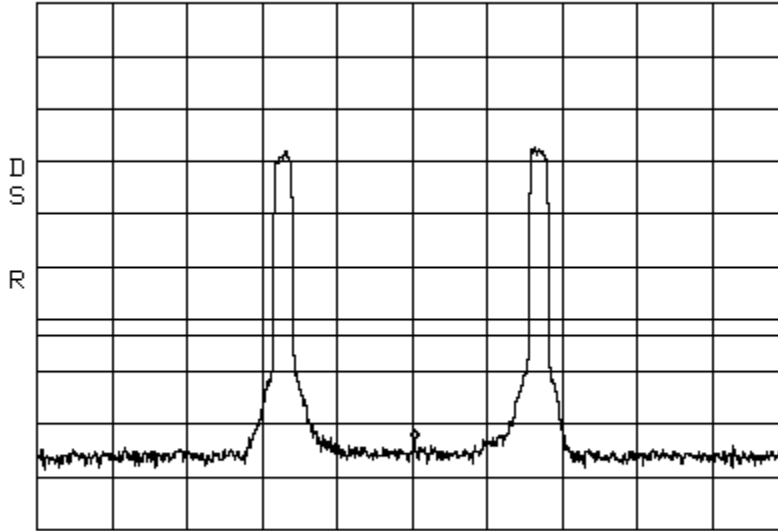

CENTER 1.9625GHz    SPAN 175.0MHz  
\*RBW 100kHz    \*VBW 100kHz    SWP 50ms

Intermodulation  
Span: 30 MHz to 1 GHz

WCDMA\_Apart

PCS 20W  
RBW/VBW: 300 kHz

ATTEN 30dB    VAUG 100    MKR -29.50dBm  
RL 50.2dBm    10dB/    920.8MHz

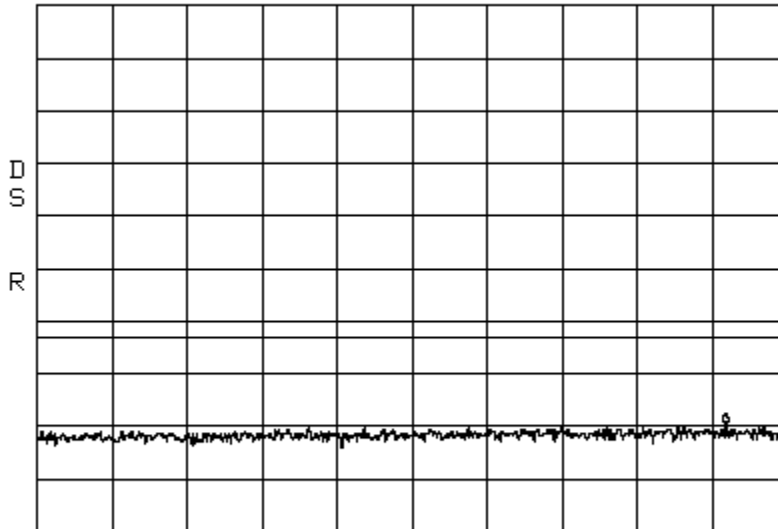

START 30.0MHz    STOP 1.0000GHz  
\*RBW 300kHz    \*VBW 300kHz    SWP 50ms



Intermodulation WCDMA\_Apart PCS 20W  
Span: 1 GHz to 5 GHz RBW/VBW: 1 MHz

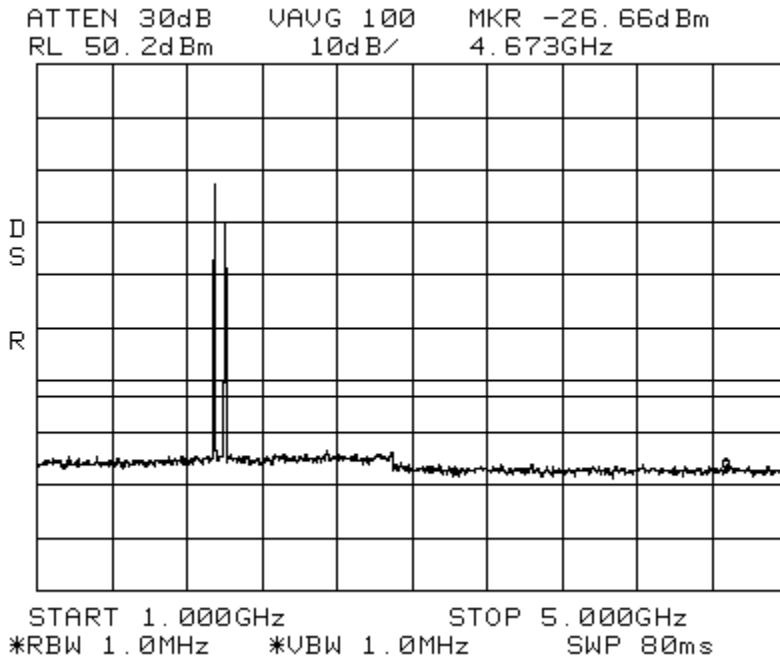

Intermodulation WCDMA\_Apart PCS 20W  
Span: 5 GHz to 20 GHz RBW/VBW: 1 MHz

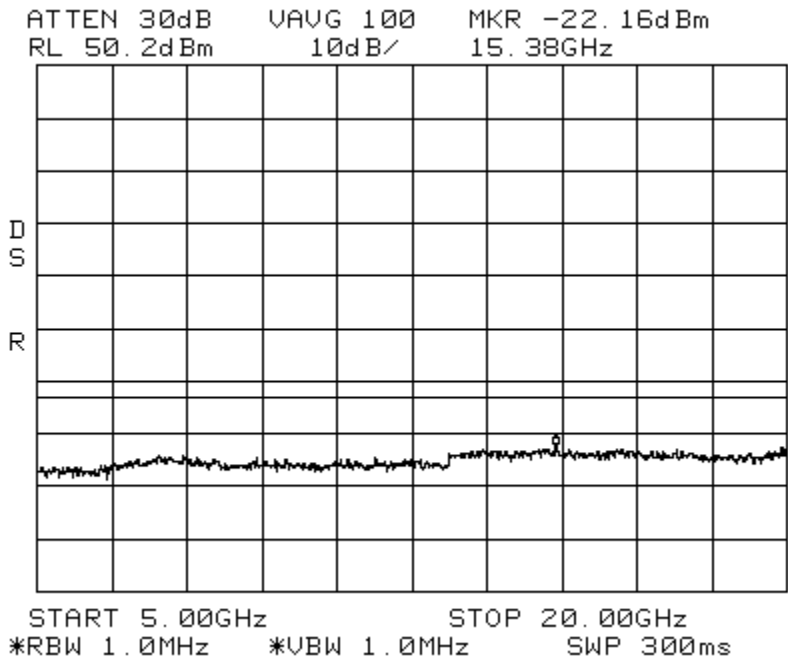

## 6.5 FCC 2.1055, 22.355, & 24.235 – Frequency Stability

### Test Summary:

- The requirements are: **• MET**      ◦ NOT MET

### Test Methods Used:

TIA-603-C 2004, ANSI C63.4-2003, FCC 2.1055, 22.355, & 24.235

### Test Procedure:

**Temperature:** The temperature is varied from -30°C to +50°C using an environmental chamber.

**Primary Supply Voltage:** Vary primary voltage from 85 to 115 percent of the nominal value for other than hand carried battery equipment.

### Test Limit:

The frequency stability shall be sufficient to ensure that the fundamental emission stays within the authorized frequency block.

**Test Date: 10/25/12**

**Tests Conducted By: Joshua J. Wittman**

**Test Equipment: 3, 4, 5, 6, 9, 11, 12**

Number	Description	Manufacturer	Model	ADC TELECOMMUNICATIONS Serial Number	Cal Due	Used
3	Multimeter	Fluke	79	MC18758	6-30-13	<input checked="" type="checkbox"/>
4	Frequency Counter	HP	5347A	MC27569	6-30-13	<input checked="" type="checkbox"/>
5	Temperature Chamber	ESPEC	PSL-4G	MC10075	9-10-13	<input checked="" type="checkbox"/>
6	Signal Generator	Aeroflex	3413	MC57343	2-9-13	<input checked="" type="checkbox"/>
9	Digital Barometer	Fisher Scientific	02-403	MC50719	1-25-13	<input checked="" type="checkbox"/>
11	Attenuator	Aeroflex	86-30-12	N/A	CNR	<input checked="" type="checkbox"/>
12	RF Power Sensor	HP	8482A	MC48747	6-30-13	<input checked="" type="checkbox"/>

### Environmental Conditions in the lab:

**Temperature:** 26° C

**Relative Humidity:** 24%

**Atmospheric Pressure:** 98.0 kPa

**Test Results:**

HOST	REMOTE			
<b>Input Voltage</b>	<b>Input Voltage</b>	<b>Carrier Frequency</b>	<b>Measured Frequency</b>	<b>Meets Requirements?</b>
21 VDC	100 VAC	869.200 MHz	869.200 MHz	Yes
48 VDC	170 VAC	869.200 MHz	869.200 MHz	Yes
60 VDC	240 VAC	869.200 MHz	869.200 MHz	Yes
21 VDC	100 VAC	881.500 MHz	881.500 MHz	Yes
48 VDC	170 VAC	881.500 MHz	881.500 MHz	Yes
60 VDC	240 VAC	881.500 MHz	881.500 MHz	Yes
21 VDC	100 VAC	893.800 MHz	893.800 MHz	Yes
48 VDC	170 VAC	893.800 MHz	893.800 MHz	Yes
60 VDC	240 VAC	893.800 MHz	893.800 MHz	Yes
<b>Temperature</b>		<b>Carrier Frequency</b>	<b>Measured Frequency</b>	<b>Meets Requirements?</b>
-30 Deg. C		869.200 MHz	869.200 MHz	Yes
-20 Deg. C		869.200 MHz	869.200 MHz	Yes
-10 Deg. C		869.200 MHz	869.200 MHz	Yes
0 Deg. C		869.200 MHz	869.200 MHz	Yes
10 Deg. C		869.200 MHz	869.200 MHz	Yes
20 Deg. C		869.200 MHz	869.200 MHz	Yes
30 Deg. C		869.200 MHz	869.200 MHz	Yes
40 Deg. C		869.200 MHz	869.200 MHz	Yes
50 Deg. C		869.200 MHz	869.200 MHz	Yes
-30 Deg. C		881.500 MHz	881.500 MHz	Yes
-20 Deg. C		881.500 MHz	881.500 MHz	Yes
-10 Deg. C		881.500 MHz	881.500 MHz	Yes
0 Deg. C		881.500 MHz	881.500 MHz	Yes
10 Deg. C		881.500 MHz	881.500 MHz	Yes
20 Deg. C		881.500 MHz	881.500 MHz	Yes
30 Deg. C		881.500 MHz	881.500 MHz	Yes
40 Deg. C		881.500 MHz	881.500 MHz	Yes
50 Deg. C		881.500 MHz	881.500 MHz	Yes
-30 Deg. C		893.800 MHz	893.800 MHz	Yes
-20 Deg. C		893.800 MHz	893.800 MHz	Yes
-10 Deg. C		893.800 MHz	893.800 MHz	Yes
0 Deg. C		893.800 MHz	893.800 MHz	Yes
10 Deg. C		893.800 MHz	893.800 MHz	Yes
20 Deg. C		893.800 MHz	893.800 MHz	Yes
30 Deg. C		893.800 MHz	893.800 MHz	Yes
40 Deg. C		893.800 MHz	893.800 MHz	Yes
50 Deg. C		893.800 MHz	893.800 MHz	Yes

HOST	REMOTE			
<b>Input Voltage</b>	<b>Input Voltage</b>	<b>Carrier Frequency</b>	<b>Measured Frequency</b>	<b>Meets Requirements?</b>
21 VDC	100 VAC	1930.200 MHz	1930.200 MHz	Yes
48 VDC	170 VAC	1930.200 MHz	1930.200 MHz	Yes
60 VDC	240 VAC	1930.200 MHz	1930.200 MHz	Yes
21 VDC	100 VAC	1962.500 MHz	1962.500 MHz	Yes
48 VDC	170 VAC	1962.500 MHz	1962.500 MHz	Yes
60 VDC	240 VAC	1962.500 MHz	1962.500 MHz	Yes
21 VDC	100 VAC	1994.800 MHz	1994.800 MHz	Yes
48 VDC	170 VAC	1994.800 MHz	1994.800 MHz	Yes
60 VDC	240 VAC	1994.800 MHz	1994.800 MHz	Yes
<b>Temperature</b>		<b>Carrier Frequency</b>	<b>Measured Frequency</b>	<b>Meets Requirements?</b>
-30 Deg. C		1930.200 MHz	1930.200 MHz	Yes
-20 Deg. C		1930.200 MHz	1930.200 MHz	Yes
-10 Deg. C		1930.200 MHz	1930.200 MHz	Yes
0 Deg. C		1930.200 MHz	1930.200 MHz	Yes
10 Deg. C		1930.200 MHz	1930.200 MHz	Yes
20 Deg. C		1930.200 MHz	1930.200 MHz	Yes
30 Deg. C		1930.200 MHz	1930.200 MHz	Yes
40 Deg. C		1930.200 MHz	1930.200 MHz	Yes
50 Deg. C		1930.200 MHz	1930.200 MHz	Yes
-30 Deg. C		1962.500 MHz	1962.500 MHz	Yes
-20 Deg. C		1962.500 MHz	1962.500 MHz	Yes
-10 Deg. C		1962.500 MHz	1962.500 MHz	Yes
0 Deg. C		1962.500 MHz	1962.500 MHz	Yes
10 Deg. C		1962.500 MHz	1962.500 MHz	Yes
20 Deg. C		1962.500 MHz	1962.500 MHz	Yes
30 Deg. C		1962.500 MHz	1962.500 MHz	Yes
40 Deg. C		1962.500 MHz	1962.500 MHz	Yes
50 Deg. C		1962.500 MHz	1962.500 MHz	Yes
-30 Deg. C		1994.800 MHz	1994.800 MHz	Yes
-20 Deg. C		1994.800 MHz	1994.800 MHz	Yes
-10 Deg. C		1994.800 MHz	1994.800 MHz	Yes
0 Deg. C		1994.800 MHz	1994.800 MHz	Yes
10 Deg. C		1994.800 MHz	1994.800 MHz	Yes
20 Deg. C		1994.800 MHz	1994.800 MHz	Yes
30 Deg. C		1994.800 MHz	1994.800 MHz	Yes
40 Deg. C		1994.800 MHz	1994.800 MHz	Yes
50 Deg. C		1994.800 MHz	1994.800 MHz	Yes

7.0

## APPENDIX B

Measurement Protocol

[Table of Contents; Section 1.0](#)

[Back to Emission Limits; Section 5.1.3](#)

# Measurement Protocol

## Test Methodology:

Emission testing is performed according to the procedures in ANSI C63.4-2003.

## Measurement Uncertainty

The test system for conducted emissions is defined as the signal generator(s), the power meter, the spectrum analyzer and the coaxial cable. The equipment comprising the test systems is calibrated prior to testing the EUT.

## Justification

The Equipment Under Test (EUT) is configured in a typical user arrangement in accordance with the manufacturer's instructions. A cable is connected to each available port and either terminated with a peripheral into its characteristic impedance or left un-terminated. When appropriate, the cables are manually manipulated with respect to each other to obtain maximum emissions from the unit.

## Radiated Emissions

The final level, in dBuV/m, equals the reading from the spectrum analyzer (Level dBuV), adding the antenna correction factor and cable loss factor (Factor dB) to it, and subtracting the preamp gain (and duty cycle correction factor, if applicable). This result then has the limit subtracted from it to provide the Delta, which gives the tabular data as shown in the data sheets in Appendix B.

Example:

FREQ (MHz)	LEVEL (dBuV)	CABLE/ANT/PREAMP (dB) (dB/m) (dB)	FINAL (dBuV/m)	POL/HGT/AZ (m) (deg)	DELTA1
60.80	42.5Qp +	1.2 + 10.9 - 25.5 =	29.1	V 1.0 0.0	-10.9

## Substitution Method

A cabinet (or enclosure) radiated emission scan was also made, at Intertek, with the EUT's antenna replaced with a termination to demonstrate case radiation compliance to the -13 dBm requirement. Radiated emissions from the EUT are measured in the frequency range of 30 to 20,000 MHz using a spectrum analyzer and appropriate broadband linearly polarized antennas. Table top equipment is placed on a 1.0 X 1.5 meter non-conducting table 80 centimeters above the ground plane. Floor standing equipment is placed directly on the turntable/ground plane. Interface cables that are closer than 40 centimeters to the ground plane are bundled in the center in a serpentine fashion so they are at least 40 centimeters from the ground plane. Cables to simulators/testers (if used in this test) are routed through the center of the table and to a screen room located outside the test area. The antenna is positioned 3 meters horizontally from the EUT. To locate maximum emissions from the test sample the antenna is varied in height from 1 to 4 meters, measurement scans are made with both horizontal and vertical antenna polarizations and the EUT are rotated 360 degrees. The field strength levels were measured per ANSI C63.4. The EUT is then replaced with a tuned dipole antenna (below 1GHz) or horn antenna (above 1 GHz). The substitute antenna was placed in the same polarization as the test antenna. A signal generator was used to generate a signal level that matched the highest level measured from the EUT. The signal generator level minus the cable loss from the signal generator to the substitute antenna plus the substitute antenna gain equals the spurious power level.

## Test Equipment

All measurement instrumentation is traceable to the National Institute of Standards and Technology and is calibrated according to internal procedure.

## Radiated Emissions Test Data

[Table of Contents; Section 1.0](#)

Document Name: *100913866MIN-001.pdf*

**Test Engineer:** Richard Blonigen

**Date:** 2 November, 2012

**Test Procedure:**

Test measurements were made in accordance with ANSI C63.4-2003, Standard Methods of Measurement of Radio Noise Emissions from Low-Voltage Electrical and Electronics Equipment in the Range of 9 kHz to 40 GHz.

**Test Site Location:**

The test site is a 3 meter Semi-Anechoic Chamber, constructed by Panashield™ Inc. and located inside the building at 7250 Hudson Blvd. Suite 100, Oakdale, MN 55128.

**Test Site Description:**

The 3 meter Semi-Anechoic Chamber is constructed of Panabolt™ modular RF shielding and self-supported with structural steel designed for the local seismic zone rating. The chamber has the nominal size of 20' wide x 29' long x 18' high. All walls and ceiling of the chamber are treated with FFG-1000 Ferrite Grid absorber which was developed specifically to meet international requirements for EMC anechoic chambers for emissions and immunity measurements. To meet high frequency testing white HY-35 hybrid absorber is mounted on the ferrites in specular regions of the chamber.

The chamber has a 2 meter diameter ANSI test volume area and meets the requirements of ANSI C63.4 (1992), EN55022, and FCC Part 15 standards for testing at a 3 meter path length.

FCC Registration Number: 0007355381

IC Registration Number: 4359A