

## TEST SETUP FOR EMISSIONS TESTING

### WILD RIVER LAB Large Test Site

Notes:

1. Items shown in dotted lines are located on the floor below the test area. It is 5 meters vertically from the ground floor to the test area.
2. 50 Hz, 60 Hz, and 400 Hz are power panels for alternating current.
3. The antenna may be positioned horizontally 3, 10 or 30 meters from the center of the turntable.
4. The circle is a 6.7 meter diameter turntable.
5. A ground plane is in the plane of this sheet.
6. The test sample is shown in the azimuthal position representing zero degrees.

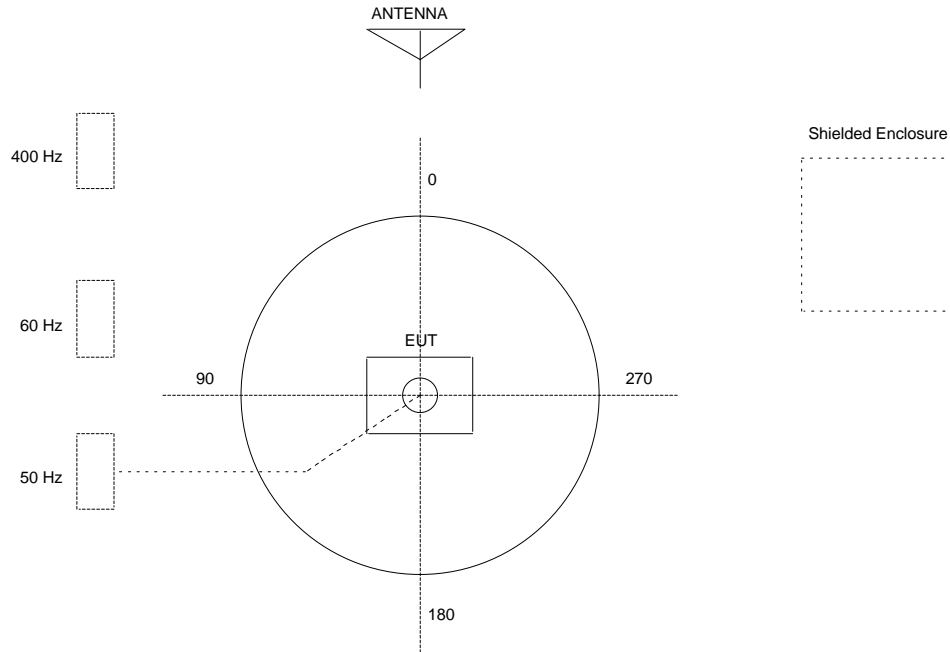

# **ADC Inc. Digivance LRCS SMR System**

## **FCC Part 90 Test set-ups**

**Inter-modulation Test for ADC Inc. DGVL-202XXSYS System.**

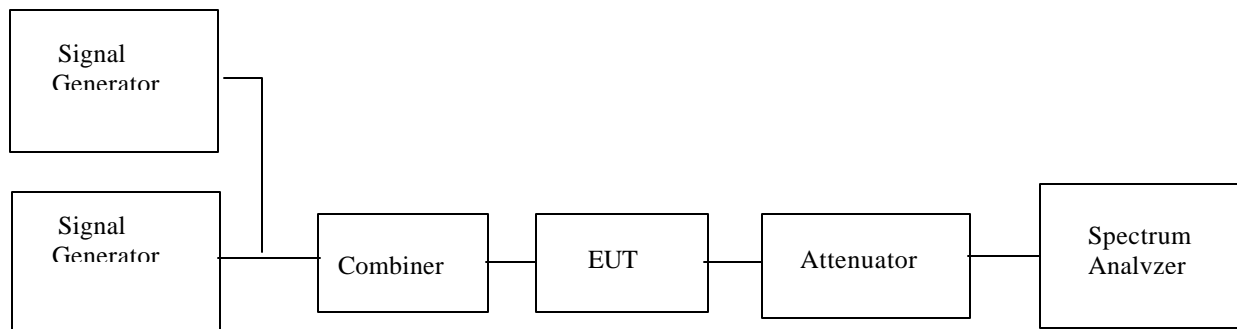

**Conducted Spurious Emissions Test for ADC Inc. DGVL-202XXSYS**

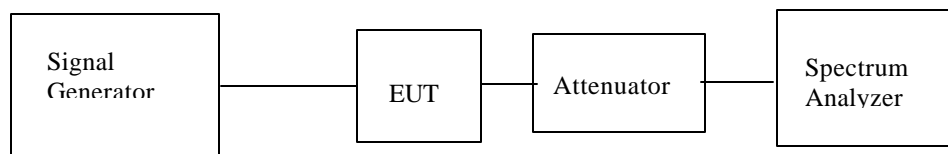

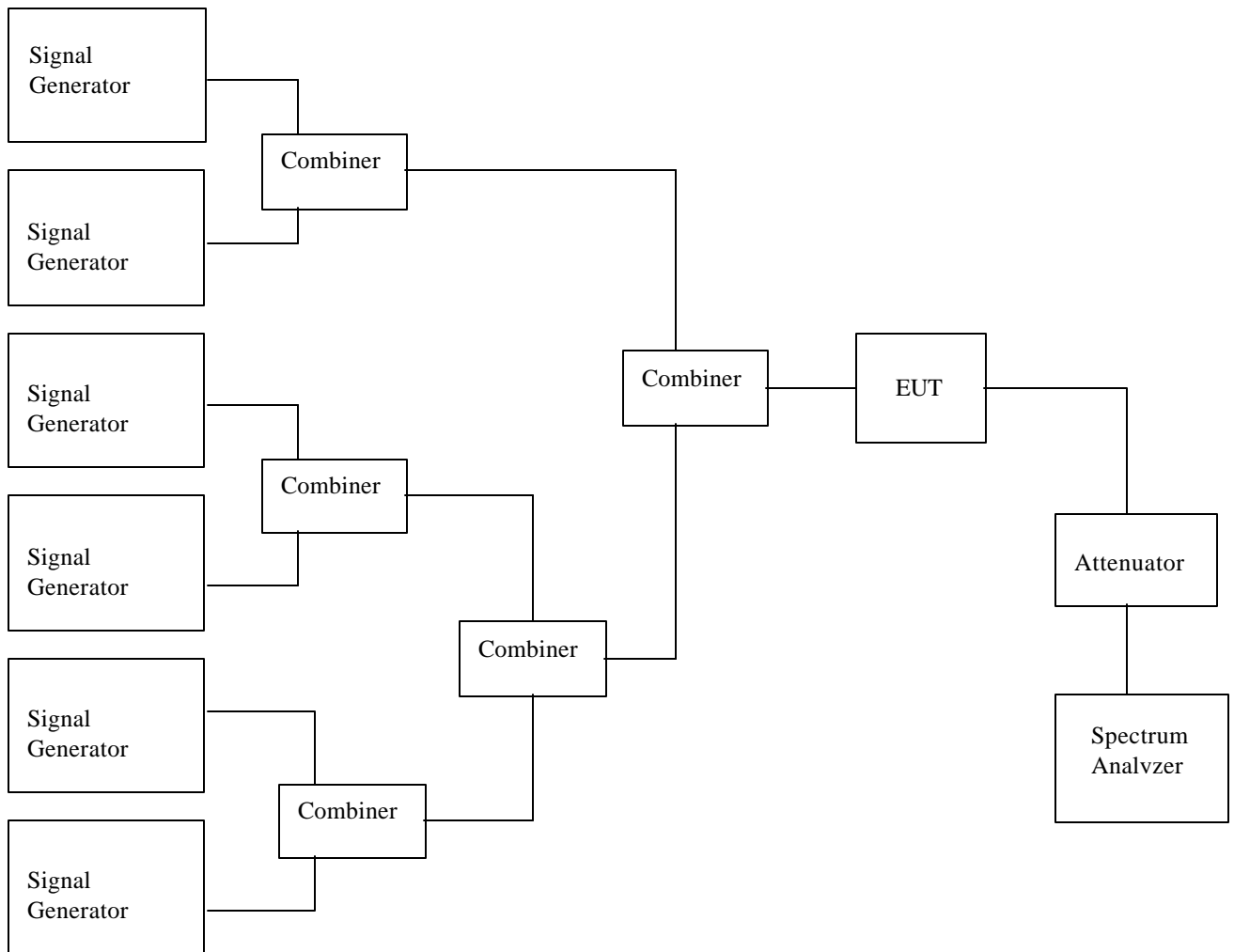

**Band Edge and Adjacent Channel test for ADC Inc. DGVL-202XXSYS**

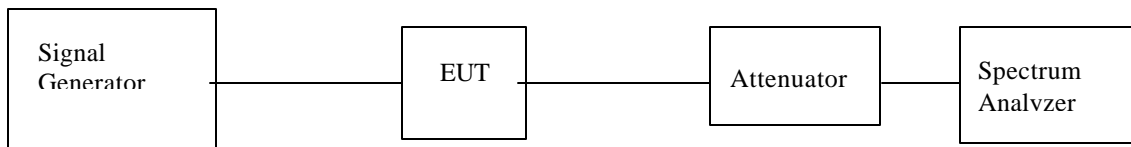

**Input versus Output Occupied Bandwidth Test for ADC Inc. DGVL-202XXSYS**

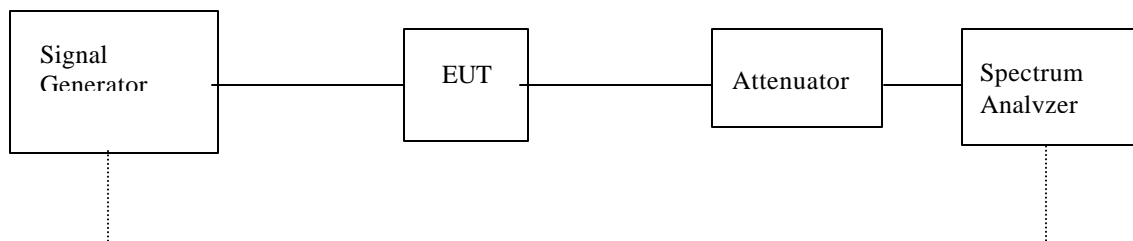

### Frequency Stability Test for ADC Inc. Digivance LRCS SMR System

