



Digivance Indoor Coverage Solution 800 Mhz Remote Interface Unit User Manual

DRAFT



COPYRIGHT

© 2001, ADC Telecommunications, Inc.
All Rights Reserved
Printed in the U.S.A.

REVISION HISTORY

ISSUE	DATE	REASON FOR CHANGE
Issue C	06/2001	Original

TRADEMARK INFORMATION

ADC and ADC Telecommunications are registered trademarks of ADC Telecommunications, Inc.

Digivance is a trademark of ADC Telecommunications, Inc.

TORX is a registered trademark of Textron, Inc.

DISCLAIMER OF LIABILITY

Contents herein are current as of the date of publication. ADC reserves the right to change the contents without prior notice. **In no event shall ADC be liable for any damages resulting from loss of data, loss of use, or loss of profits and ADC further disclaims any and all liability for indirect, incidental, special, consequential or other similar damages. This disclaimer of liability applies to all products, publications and services during and after the warranty period.**

This publication may be verified at any time by contacting ADC's Technical Assistance Center at 1-800-366-3891, extension 63475 (in U.S.A. or Canada) or 952-946-3475 (outside U.S.A. and Canada), or by e-mail to bcg_tac@adc.com.



ADC Telecommunications, Inc.
P.O. Box 1101, Minneapolis, Minnesota 55440-1101
In U.S.A. and Canada: 1-800-366-3891
Outside U.S.A. and Canada: (952) 938-8080
Fax: (952) 946-3292

TABLE OF CONTENTS

Content	Page
1 DESCRIPTION	1
1.1 Primary Functions and Components	1
1.2 Mounting	2
1.3 Fault Detection and Alarm Reporting	3
1.4 RF Signal Connections	3
1.5 RF Signal Level Adjustments	3
1.6 Powering	3
1.7 Cooling	3
1.8 User Interface	4
1.9 Specifications	5
2 INSTALLATION	7
2.1 Tools and Materials	7
2.2 Unpacking and Inspections	7
2.3 Mounting Procedure	8
2.4 Chassis Ground Connection	11
2.5 Coaxial Cable Connections	12
2.6 External Alarm System Connections	14
2.7 AC Power Connection	15
3 OPERATION	17
3.1 Tools and Materials	17
3.2 Turn-Up Unit and Verify Operation	17
3.3 Forward Path Level Adjustment	18
3.4 Reverse Path Level Adjustment	21
4 MAINTENANCE	22
4.1 Tools and Materials	22
4.2 Fault Detection and Alarm Reporting	22
4.3 Fan Replacement	23
5 CUSTOMER INFORMATION AND ASSISTANCE	25

ABOUT THIS MANUAL

This publication provides a description of the Digivance ICS Remote Interface Unit (RIU) plus instructions for installing the RIU. An overview of the Digivance ICS and a complete description of the Digital Host Unit (DHU), Digital Remote Unit (DRU) and the Digital Expansion Unit (DEU) are provided in the Digivance ICS Installation and Operation Manual (ADCP-75-110). The RIU is an interface device that is used in conjunction with the Digivance ICS product.

RELATED PUBLICATIONS

Listed below are related manuals and their publication numbers. Copies of these publications can be ordered by contacting the ADC Technical Assistance Center at 1-800-366-3891 (in U.S.A. or Canada) or 952-946-3000, extension 63475 (outside U.S.A. and Canada).

Title/Description	ADCP Number
<p>Digivance ICS Installation and Operation Manual</p> <p>Provides an overview of the Digivance ICS, a complete description of the DHU, DRU, and DEU, system planning and engineering guidelines, DHU installation instructions, system turn-up and test procedures, and system troubleshooting and maintenance procedures.</p>	ADCP-75-110
<p>Digivance ICS Digital Expansion Unit Installation Instructions</p> <p>Provides a description of the DEU and procedures for installing the DEU.</p>	ADCP-75-111
<p>Digivance ICS Digital Remote Unit Installation Instructions</p> <p>Provides a description of the DRU and procedures for installing the DRU.</p>	ADCP-75-112
<p>Digivance ICS Local Interface Unit User Manual</p> <p>Provides a description of the LIU and procedures for installing the LIU.</p>	ADCP-75-113

ADMONISHMENTS

Important safety admonishments are used throughout this manual to warn of possible hazards to persons or equipment. An admonishment identifies a possible hazard and then explains what may happen if the hazard is not avoided. The admonishments — in the form of Dangers, Warnings, and Cautions — must be followed at all times. These warnings are flagged by use of the triangular alert icon (seen below), and are listed in descending order of severity of injury or damage and likelihood of occurrence.



Danger: *Danger is used to indicate the presence of a hazard that **will** cause severe personal injury, death, or substantial property damage if the hazard is not avoided.*



Warning: *Warning is used to indicate the presence of a hazard that **can** cause severe personal injury, death, or substantial property damage if the hazard is not avoided.*



Caution: *Caution is used to indicate the presence of a hazard that **will** or **can** cause minor personal injury or property damage if the hazard is not avoided.*

GENERAL SAFETY PRECAUTIONS



Warning: *Wet conditions increase the potential for receiving an electrical shock when installing or using electrically powered equipment. To prevent electrical shock, never install or use electrical equipment in a wet location or during a lightning storm.*

STANDARDS CERTIFICATION

FCC: This equipment complies with the applicable sections of Title 47 CFR Part 22.

UL/CUL: This equipment complies with UL and CUL 1950 Standard for Safety for Information Technology Equipment, Including Electrical Business Equipment.

IC (Industry Canada): This equipment complies with IC Certification RSS-131.

LIST OF ACRONYMS AND ABBREVIATIONS

The acronyms and abbreviations used in this manual are detailed in the following list:

A	Amperes
AC	Alternating Current
CUL	Canadian Underwriters Laboratories
DC	Direct Current
DEU	Digital Expansion Unit
DHU	Digital Host Unit
DRU	Digital Remote Unit
EIA	Electronic Industries Association
ESD	Electrostatic Discharge
FCC	Federal Communications Commission
IC	Industry Canada
ICS	Indoor Coverage Solution
LIU	Local Interface Unit
NOC	Network Operations Center
RIU	Remote Interface Unit

RF Radio Frequency
UL Underwriters Laboratories
V Volts
VAC Volts Alternating Current
VDC Volts Direct Current
WECO Western Electric Company

1 DESCRIPTION

This section provides a complete description of the Remote Interface Unit (RIU).

1.1 Primary Functions and Components

The RIU, shown in Figure 1, serves as the interfacing unit between a remote BTS and the Digivance DHU. The RIU provides the following basic functions:

- RF interface to the BTS (through donor antenna) and DHU
- Gain adjustments to the forward and reverse path RF signal
- Duplexing of the forward and reverse path RF signals
- Alarm reporting to an external alarm system

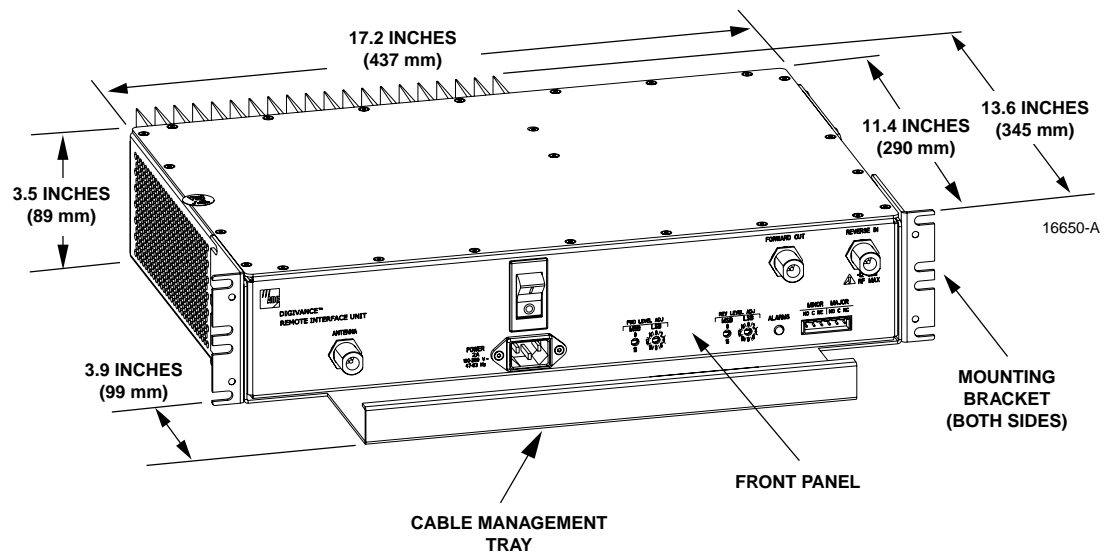

Figure 1. Remote Interface Unit

A remote interface between the DHU and the BTS (cell site base station) via a donor antenna requires specific RF input and output signal levels at the DHU and antenna. The correct levels at the DHU and antenna can be provided using the RIU. The RIU provides adjustable gain in both the RF forward and reverse paths. The RIU connects to a directional antenna through a duplexer which provides separate forward and reverse path connections for the DHU. In the forward path (downlink), the RIU provides the recommended composite maximum RF input signal level at the DHU which is **-20 dBm**. When the level of the RF input signal at the DHU is **-20 dBm**, the level of the RF output signal at the DRU is **+13 dBm** which is the maximum allowed.

In the reverse path, the required RF output signal level to the donor antenna will vary depending on the DRU path loss. When the level of the reverse path (uplink) signal at the DRU is at the recommended composite maximum level of **-40 dBm**, the level of the RF output signal from the DHU is **-30 dBm**. Therefore, it will generally be necessary to add some gain to the reverse path signal in order to achieve the required output signal level at the donor antenna. A block diagram showing a typical **remote** DHU to BTS interface is provided in Figure 2.

The RIU consists of an electronic circuit board assembly, power supply, duplexer, and linear power amplifier that are mounted within a powder-coated sheet metal enclosure. The metal enclosure provides a mounting point for the electronic components, serves as a heat sink, and controls RF emissions. Except for the fan, the electronic components are not user replaceable. The RIU is designed for use within a non-condensing indoor environment such as inside a wiring closet or cabinet. All controls, connectors, and indicators are mounted on the RIU front panel for convenient access. Cable management functions for the power and coaxial cables are provided by a cable management tray that extends outward from the RIU front panel.

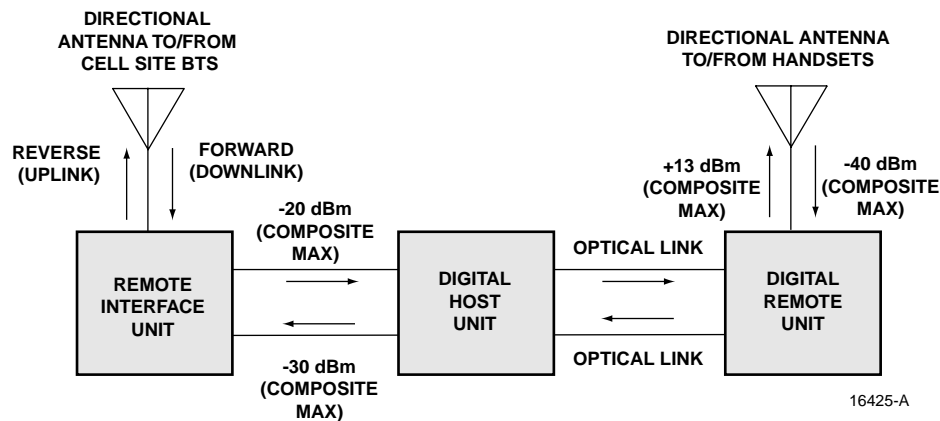

Figure 2. Remote BTS Interface Block Diagram

Two versions of the 800 Mhz RIU are available. One version is used to interface with an A-band BTS and the other version is used to interface with a B-band BTS. The frequency (800 Mhz) and band (A or B) are clearly marked on a label attached to the RIU cable management tray.

1.2 Mounting

The RIU may be used in both rack-mount and wall-mount applications. For rack mount applications, a pair of reversible mounting brackets is provided that allow the RIU to be mounted in either a 19-inch or 23-inch EIA or WECO equipment rack. When rack-mounted, the front panel of the RIU is flush with the front of the rack. The cable management tray extends 3.9 inches (99 mm) beyond the front panel. Fasteners are provided for rack-mount applications.

For wall-mount applications, a pair of holes is provided in the cable management tray which allow the RIU to be mounted on any flat vertical surface. The mounting brackets may also be removed and reinstalled in such a way as to be used to secure the RIU to a flat vertical surface. The RIU should be oriented with the front panel facing upward when wall-mounted. The fasteners must be provided by the installer in wall-mount applications.

1.3 Fault Detection and Alarm Reporting

The RIU is designed to detect a power amplifier over or under current condition and a high temperature condition. A single front panel Light Emitting Diode (LED) indicator turns from green to red or yellow if a fault is detected. A set of alarm contacts (normally open and normally closed) are also provided for reporting an alarm to an external alarm system when a fault is detected. Both major alarm (power amplifier over/undercurrent condition or power failure) and minor alarm (high temperature) contacts are provided.

1.4 RF Signal Connections

The RF signal connections between the RIU and DHU are supported through a pair of type N female connectors mounted on the RIU front panel. One connector is used for connecting the forward path coaxial cable and the other connector is used for connecting the reverse path coaxial cable. The RF signal connection between the RIU and the donor antenna is supported through a single type N female connector. The single connector is used for connecting the coaxial jumper cable that links the RIU to the donor antenna. The DHU cannot be connected directly to a donor antenna and requires an interface device such as the RIU.

- **Note:** To comply with Maximum Permissible Exposure (MPE) requirements, antennas must be installed to provide at least **20 centimeters** (8 inches) of separation from all persons per FCC 47 CFR part 2.1091.

1.5 RF Signal Level Adjustments

The RIU is equipped with two digital attenuators for adjusting the signal levels of the forward and reverse path RF signals. The attenuators provide an attenuation adjustment range of 0 to 31 dB and can be set in 1 dB increments. In the **forward path**, this range provides a maximum gain of +40 dB (with attenuator set to 0) or a minimum gain of +9 dB (with attenuator set to 31 dB). In the **reverse path**, this range provides a maximum gain of +59 dB (with attenuator set to 0) or a minimum gain of +28 dB (with attenuator set to 31 dB). Each attenuator is adjustable by means of two rotary switches which are mounted behind the RIU front panel. Access to each rotary switch is through a small hole. A small screwdriver is required to adjust the switch setting. Turning each switch adds or removes attenuation and therefore adjusts the signal level of the specified signal path.

1.6 Powering

The RIU is powered by 120/240 VAC (50–60 Hz) power which is supplied through a standard three-conductor AC power cord. The power cord is provided with the RIU and is 98 inches (2.5 meters) long. A resettable circuit breaker/On-Off switch is provided at the unit front panel. The switch applies power to the RIU internal power supply.

1.7 Cooling

Continuous air flow for cooling is provided by a fan mounted on the right side of the housing. A minimum of 3 inches (76 mm) of clearance space must be provided on both the left and right sides of the RIU for air intake and exhaust. An alarm is provided that indicates if a high temperature condition (>58° C/136° F) occurs. The fan may be field-replaced if it fails.

1.8 User Interface

The RIU user interface consists of the various connectors, switches, terminals, and LED that are provided on the RIU front panel. The RIU user interface points are indicated in Figure 3 and described in Table 1.

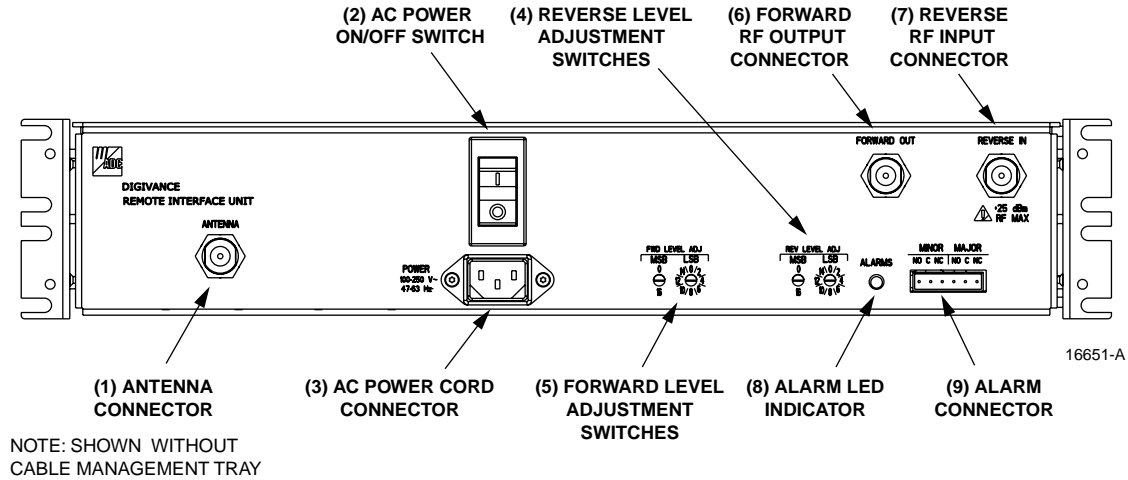

Figure 3. Remote Interface Unit User Interface

Table 1. Remote Interface Unit User Interface

REF No.	USER INTERFACE DESIGNATION	DEVICE	FUNCTIONAL DESCRIPTION
1	ANTENNA	N-type female RF coaxial connector	Used for connecting the donor antenna coaxial cable.
2	I/O	I/O rocker switch/circuit breaker	Provides AC power On/Off control and AC power over current protection.
3	POWER	3-wire AC power cord connector	Used for connecting the AC power cord.
4	REV LEVEL ADJ MSB LSB	Rotary switch	Used to adjust the reverse path RF signal level by adding or removing attenuation.
5	FWD LEVEL ADJ MSB LSB	Rotary switch	Used to adjust the forward path RF signal level by adding or removing attenuation.
6	FORWARD OUT	N-type female RF coaxial connector	Used for connecting the RIU to DHU forward path coaxial cable.
7	REVERSE IN	N-type female RF coaxial connector	Used for connecting the DHU to RIU reverse path coaxial cable.
8	ALARMS	Multi-colored LED (Red/Green/Yellow)	Indicates if the RIU is normal or faulty. (see Section 3 for a detailed description)
9	MINOR MAJOR	Screw-type terminal connector (14–26 AWG)	Used for connecting the RIU to an external alarm system. Includes normally open (NO), normally closed (NC), and common (COM) wiring connections.

1.9 Specifications

The specifications for the RIU are provided in Table 2. All specifications apply after a five minute warm-up period.

Table 2. Remote Interface Unit Specifications

PARAMETER	SPECIFICATION	REMARKS
Environmental		
Operating Temperature	0° to 50° C (32° to 122° F)	
Storage Temperature	-30° to +70° C (-22 to 158° F)	
Humidity	No condensation	
Weather resistance	Indoor installation only	
RF Forward Path		
A-band frequency range	869 to 891.5 MHz	
B-band frequency range	880-894 MHz	
RF Gain	+9 to +40 dB	Adjustable in 1 dB steps
Gain Variation	± 1.5 dB	Over frequency, temperature, and unit-to-unit.
Gain stepsize accuracy	± (0.2 + 3% of gain setting in dB) dB	
Output power	-20 dBm composite maximum to Digivance ICS input	With proper attenuation setting
Input level	-29 dBm composite maximum	To drive Digivance ICS DHU
VSWR	1.5:1 or better, both ports	
IP3	≥ +30 dBm	
RF Reverse Path		
A-band frequency range	824 to 835 and 845 to 846.5 MHz	
B-band frequency range	835 to 849 MHz	
RF Gain	+29 to +59 dB	Adjustable in 1 dB steps
Gain Variation	±1.5 dB	Over frequency, temperature, and unit-to-unit.
Gain stepsize accuracy	± (0.2 + 3% of gain setting in dB) dB	
Output power	+ 29 dBm composite maximum	When driven with Digivance ICS DHU
Input level	-30 dBm composite maximum	From Digivance ICS DHU output
VSWR	1.5:1 or better, both ports	
IP3	≥ +46 dBm	

Continued

Table 2. Remote Interface Unit Specifications (Continued)

PARAMETER	SPECIFICATION	REMARKS
Physical		
Weight	20.2 lbs (8.7 kg)	
Dimensions (H×W×D)	3.5 × 19.0 × 17.25 Inches (89 × 482 × 438 mm)	
Color	Putty white	
RF connections	Type N	Female
Alarm connection	Screw terminals (14–26 AWG)	NO, NC, and COM
Reliability	MTBF 80,000 hours	
Electrical		
Power source	120–240 VAC, 50–60 Hz	
AC Connection	IEC 320	Male
Power consumption	250 W	Maximum
Current rating	85–250 VAC, 2 Amp input	
Donor Antenna		
Type	Directional	
Gain	15 dB or greater	

2 INSTALLATION

This section provides the installation procedures for the RIU. Installation of the various Digivance ICS units may proceed separately from the installation of the RIU.

2.1 Tools and Materials

The following tools are required in order to complete the procedures in this section:

- Box cutter
- Pencil or scribe
- Medium and small size flat-bladed screwdrivers
- Phillips screwdriver (#2)
- TORX screwdriver (T20)
- Wire cutters
- Wire stripper
- Tool kit for attaching N-type male connectors to coaxial cable
- Drill and assorted drill bits (wall-mount installations only)

The following materials are required in order to complete the procedures in this section:

- Wall-mount fasteners (wall-mount applications only)
- #22 AWG (0.40 mm) category 3 or 5 cable (for external alarm connections)
- #18 AWG (1.00 mm) insulated stranded copper wire (for chassis grounding wire)
- Ring terminal for #18 wire (for chassis ground wire connection)
- High performance, flexible, low loss 50-ohm coaxial cable
- N-type male connectors
- Wire ties

2.2 Unpacking and Inspection

This sub-section provides instructions for opening the shipping boxes, verifying that all parts have been received, and verifying that no shipping damage has occurred. Use the following procedure to unpack and inspect the RIU:

1. Open the shipping carton and carefully unpack the RIU from the protective packing material.
2. Check the RIU for broken or missing parts. If there are any damages, contact ADC (see section 5 at the end of this manual) for an RMA (Return Material Authorization) and to reorder if replacement is required.

2.3 Mounting Procedure

The RIU may be either rack-mounted or wall-mounted. Of the procedures that follow, use whichever procedure is appropriate for the installation.

2.3.1 Rack-Mount Installation

The RIU may be mounted in either a 19-inch or 23-inch EIA or WECO equipment rack. Both US standard and metric machine screws are included for rack mounting the RIU. When loading the RIU in a rack, make sure the mechanical loading of the rack is even to avoid a hazardous condition such as a severely unbalanced rack. The rack should safely support the combined weight of all the equipment it holds. In addition, the maximum recommended ambient temperature for the RIU is 50° C (122° F). Allow sufficient air circulation or space between units when the RIU is installed in a multi-unit rack assembly because the operating ambient temperature of the rack environment might be greater than room ambient.



Warning: *Wet conditions increase the potential for receiving an electrical shock when installing or using electrically-powered equipment. To prevent electrical shock, never install or use electrical equipment in a wet location or during a lightning storm.*

Use the following procedure to install the RIU in the equipment rack:

1. The RIU is shipped with the mounting brackets installed for 19-inch rack installations. If mounting the RIU in a 19-inch rack, proceed to step 4. If mounting the RIU in a 23-inch rack, proceed to step 2.
2. Remove both mounting brackets from the RIU (requires TORX screwdriver with T20 bit).
3. Reinstall both mounting brackets so the long side of the bracket is flush with the RIU front panel as shown in Figure 4. Use the screws removed in step 2 to re-attach the brackets to the RIU enclosure.

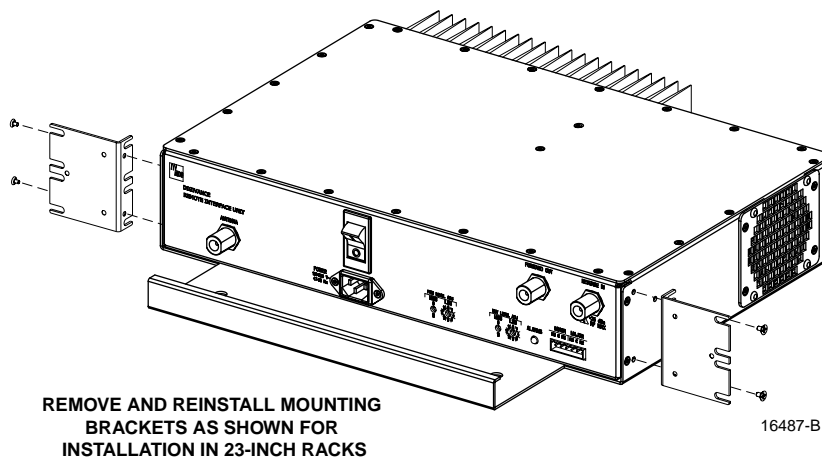

Figure 4. Installing the Mounting Brackets for 23-Inch Rack Installations

4. Position the RIU in the designated mounting space in the rack (per system design) and then secure the mounting brackets to the rack using the four machine screws provided (use #12-24 screws or M6 x 10 screws, whichever is appropriate) as shown in Figure 5.

► **Note:** Provide a minimum of 3 inches (76 mm) of clearance space on both the left and right sides of the RIU for air intake and exhaust.

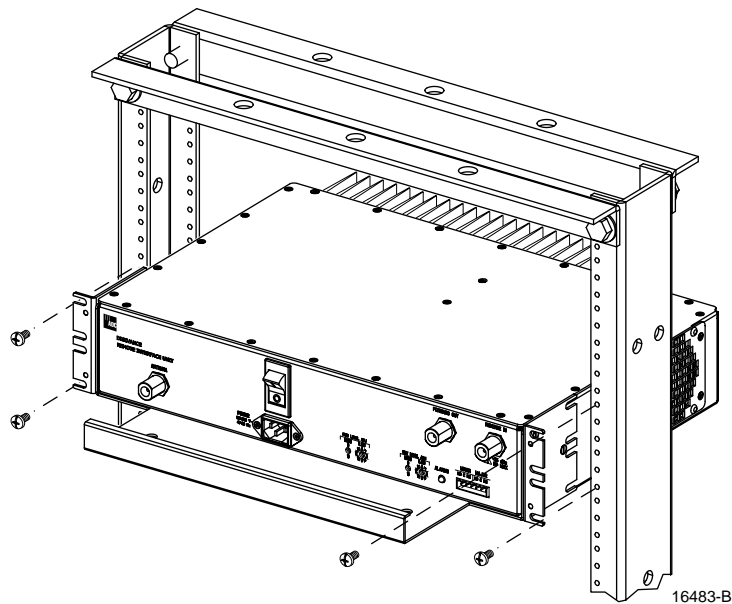

Figure 5. RIU Rack Mount Installation

2.3.2 Wall-Mount Installation

The RIU may be mounted from any flat vertical surface. It is recommended that a backer board such as 3/4-inch plywood be applied over the mounting surface to provide a secure base for attaching the RIU. Two mounting holes are provided in the cable management tray for securing the RIU to the mounting surface. In addition, the mounting brackets may be removed and then reinstalled in such a way that they can be used for securing the RIU to the mounting surface. Either method for mounting may be used at the discretion of the installer. The fasteners must be provided by the installer. Use the following procedure to wall-mount the RIU:



Warning: *Wet conditions increase the potential for receiving an electrical shock when installing or using electrically-powered equipment. To prevent electrical shock, never install or use electrical equipment in a wet location or during a lightning storm.*

1. Obtain the appropriate fasteners (lag bolts, screw anchors, etc.) for securing the RIU to the mounting surface.
2. If the mounting brackets will be used to secure the RIU to the mounting surface, proceed to step 3. If the mounting brackets **will not** be used to secure the RIU to the mounting surface, skip steps 3 and 4 and proceed to step 5.

3. Remove both mounting brackets from the RIU (requires TORX screwdriver with T20 bit).
4. Reinstall both mounting brackets so the short side of the bracket is flush with the bottom of the RIU as shown in Figure 6. Use the screws removed in step 3 to re-attach the brackets to the RIU enclosure.

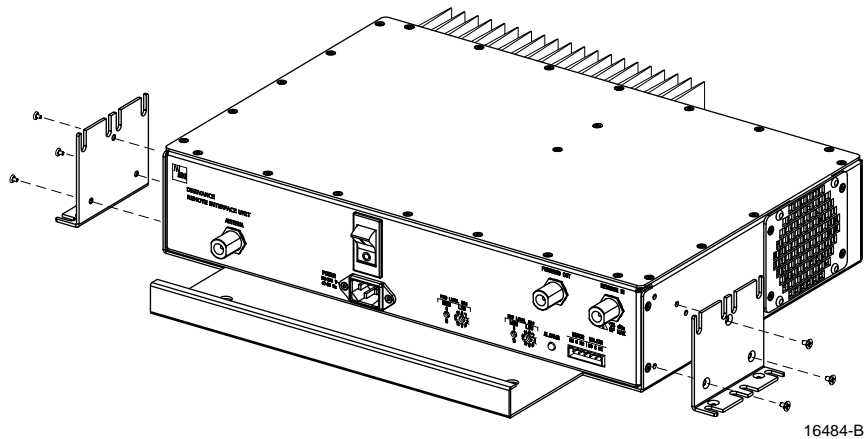

Figure 6. Installing the Mounting Brackets for Wall-Mount Installation

5. Position the RIU on the mounting surface in the specified location (per the system design) with the front panel facing up as shown in Figure 7.
 - ▶ **Note:** Provide a minimum of 3 inches (76 mm) of clearance space on both the left and right sides of the RIU for air intake and exhaust.
6. Using the RIU as a template, mark the location of the mounting holes on the mounting surface.
 - ▶ **Note:** The mounting holes in the RIU cable management tray are spaced 11-21/32 inches (296 mm) center to center.
7. Set the RIU aside and then drill appropriately sized holes in the mounting surface for the fasteners.
8. If using **only** the mounting brackets to secure the RIU to the mounting surface, skip step 9 and proceed to step 10. If using the cable management tray mounting holes to secure the RIU to the mounting surface, proceed to step 9.
9. Partially install the fasteners for the cable management tray mounting holes. Leave the head of each fastener protruding about 1/4 inch (6 mm) from the mounting surface.
10. Hang the RIU from the fasteners installed in step 9 or position the RIU for installation if using only the mounting brackets.
11. Install and securely tighten all fasteners.

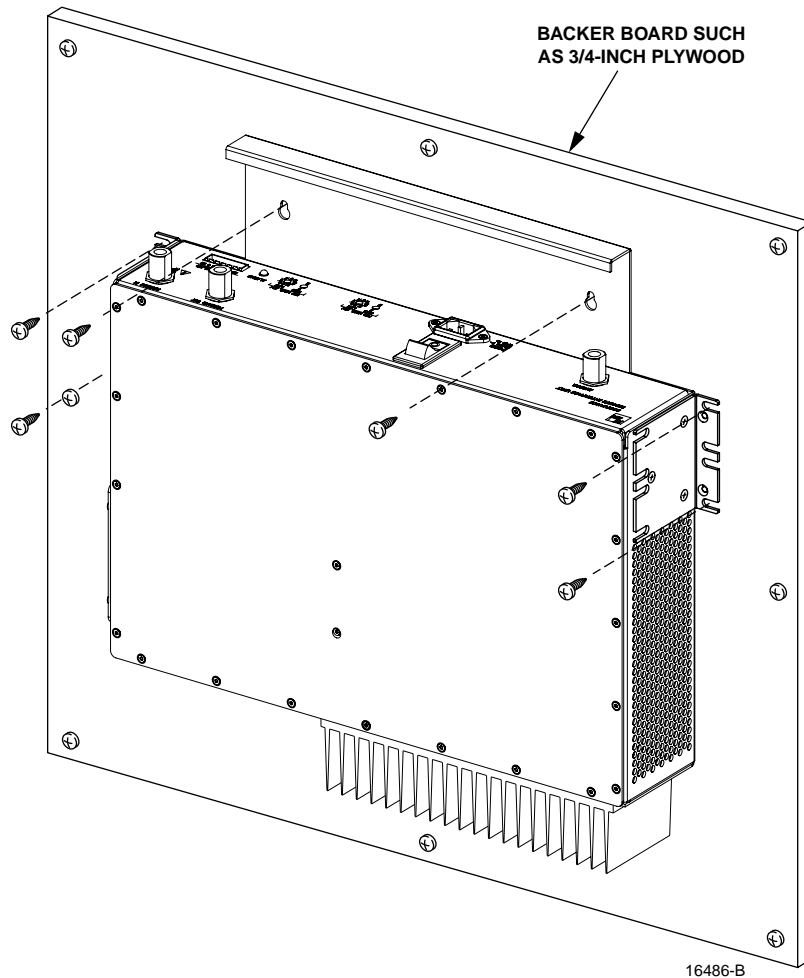

Figure 7. RIU Wall-Mount Installation

2.4 Chassis Ground Connection

A stud is provided on the rear side of the chassis for connecting a grounding wire to the chassis. Use the following procedure to connect the grounding wire to the chassis and to route the grounding wire to an approved earth ground source:

1. Obtain a length of #18 AWG (1.00 mm) insulated **stranded** copper wire for use as a chassis grounding wire.
2. Terminate one end of the wire with a ring terminal.
3. Locate the chassis ground stud at the rear of the RIU as shown in Figure 8.
4. Attach the ring end of the wire to the chassis ground stud (see Figure 8).
5. Route the free end of the chassis grounding wire to an approved (per local code or practice) earth ground source.

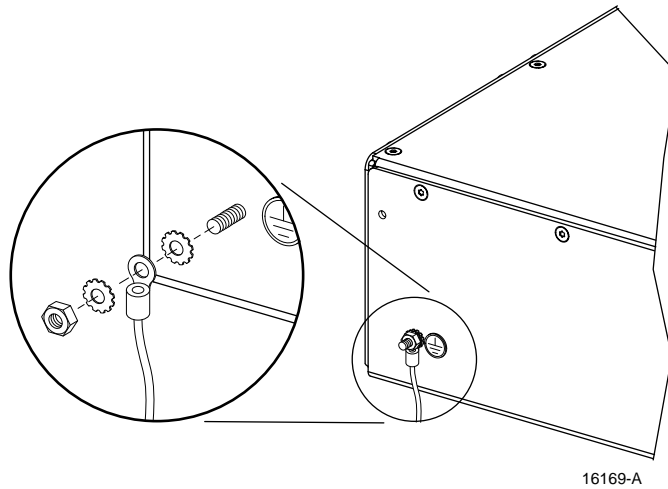

Figure 8. Chassis Ground Stud

6. Cut the chassis grounding wire to length and connect it to the approved ground source as required by local code or practice.
- **Note:** Be sure to maintain reliable grounding for rack and wall mounted equipment. Pay particular attention to ground source connections.

2.5 Coaxial Cable Connections

The RF signal connections between the RIU and DHU are supported through a pair of type N female connectors mounted on the RIU front panel. One connector is used for connecting the forward path coaxial cable and the other connector is used for connecting the reverse path coaxial cable. The RF signal connection between the RIU and the donor antenna is supported through a single type N female connector. The single connector is used for connecting the coaxial jumper cable that links the RIU to the donor antenna.

2.5.1 Forward and Reverse Path Coaxial Cable Connections

Use the following procedure to install the forward and reverse path coaxial cables that link the RIU to the DHU:

1. Locate the forward and reverse path coaxial cables that were routed to the RIU from the DHU.
- **Note:** The procedures for routing the reverse and forward path coaxial cables from the DHU to the RIU and for connecting the cables to the DHU are covered in the Digivance ICS Installation and Operation Manual (ADCP-75-110) which is provided with the DHU.
2. Terminate each cable with a type N male connector following the connector supplier's recommendations.
 3. Connect the forward path cable to the **FORWARD OUT** connector on the RIU front panel as shown in Figure 9.

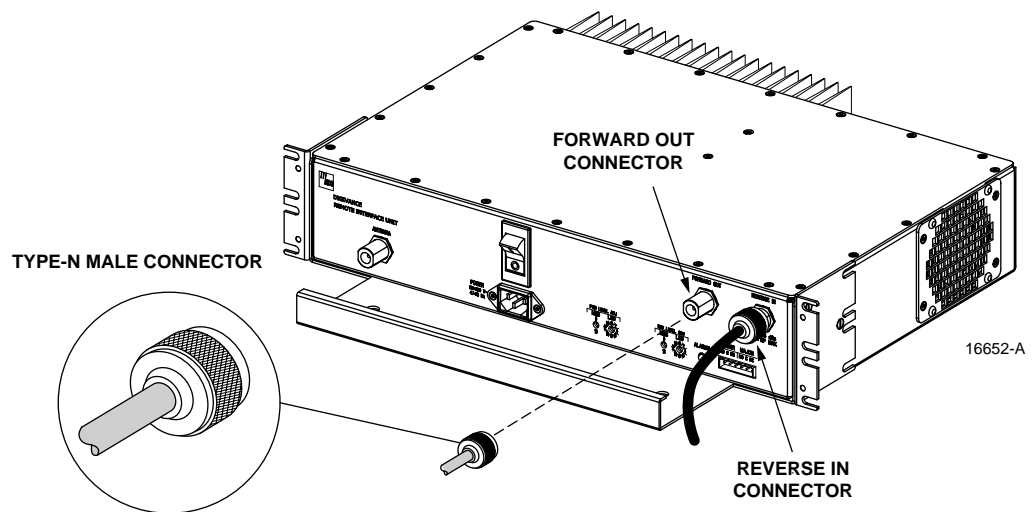

Figure 9. FORWARD OUT and REVERSE IN Coaxial Cable Connections

4. Connect the reverse path cable to the **REVERSE IN** connector on the RIU front panel as shown in Figure 9.
5. Dress and secure cables at the RIU.

2.5.2 Antenna Coaxial Cable Connection

Use the following procedure to install the coaxial cable that links the RIU to the donor antenna:

► **Note:** To comply with Maximum Permissible Exposure (MPE) requirements, antennas must be installed to provide at least **20 centimeters** (8 inches) of separation from all persons per FCC 47 CFR part 2.1091.

1. Obtain the required length of high performance, flexible, low loss 50-ohm coaxial communications cable for the antenna coaxial connection.
2. Route the coaxial cable between the RIU and the donor antenna (per system design) and cut to the required length. Allow sufficient slack for dressing and organizing cables at the RIU and antenna.
3. Terminate each cable end with a type N male connector following the connector supplier's recommendations.
4. Connect the RIU end of the antenna cable to the **ANTENNA** connector on the RIU front panel as shown in Figure 10.
5. Connect the antenna end of the antenna cable to the donor antenna.
6. Dress and secure cables at the RIU and donor antenna.

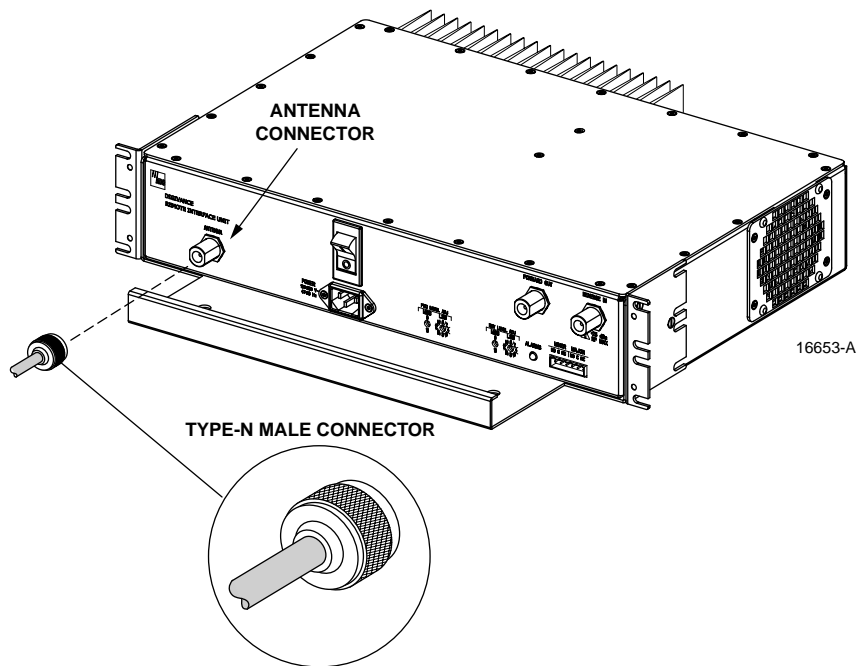

Figure 10. RIU Antenna Cable Connection

2.6 External Alarm System Connections

The alarm interface between the RIU and an external alarm system is supported by a six-terminal plug (with screw-type terminals) that connects to a receptacle on the RIU front panel. The terminal plug provides connections to normally open (NO) and normally closed (NC) dry type alarm contacts for both minor and major alarms. A category 3 or 5 cable is typically used to connect the RIU to the external alarm system. Use the following procedure to install the alarm wiring and connect it to the RIU:

1. Obtain the required length of category 5 cable.
2. Route the cable between the RIU and the external alarm system (if not already routed) and then cut to required length. Allow sufficient slack for dressing and organizing the cable at the RIU.
3. Strip back the outer cable sheath and insulation to expose the wires at both ends of the cable and strip back 0.2 inches (5 mm) of insulation each wire.
4. Connect the Major alarm wire pair to the **MAJOR COM/NC** or **MAJOR COM/NO** terminals (whichever is required by the external alarm system) on the RIU alarm terminal connector (supplied with RIU) as shown in Figure 11.

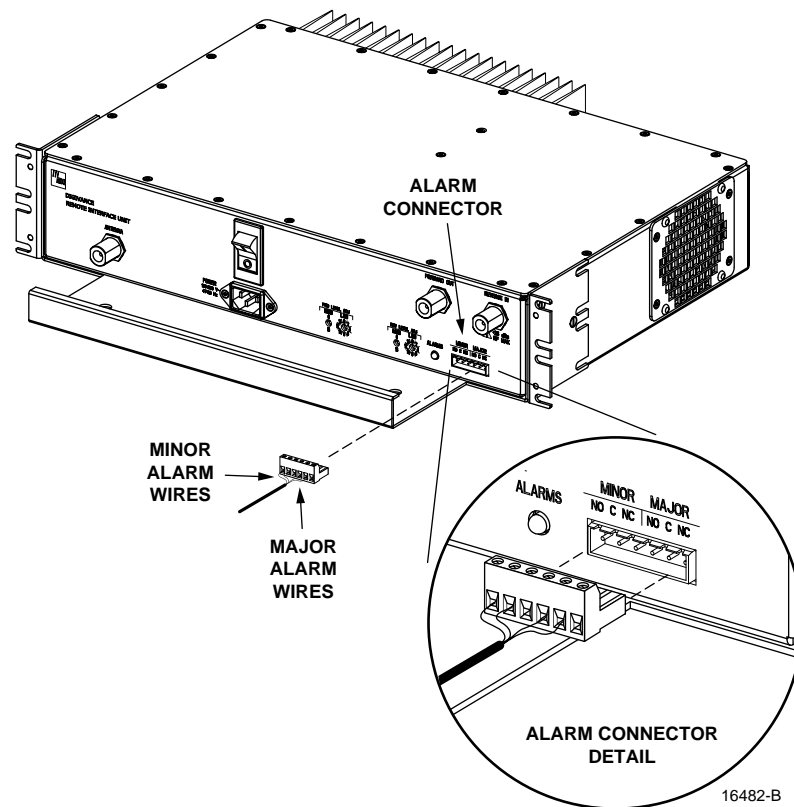

Figure 11. External Alarm System Connections

5. Connect the Minor alarm wire pair to the **MINOR COM/NC** or **MINOR COM/NO** terminals (whichever is required by the external alarm system) on the RIU alarm terminal connector as shown in Figure 11.
6. Connect the Major and Minor alarm wire pairs to the appropriate terminals on the external alarm system.
7. Dress and secure cable.

2.7 AC Power Connection

The AC power interface between the RIU and the AC power source is supported by a 3-wire AC power cord connector located on the RIU front panel. The AC connector provides a connection point for the power cord which is provided separately with the RIU. Use the following procedure to install the AC power cord:

1. Place the RIU AC power ON/OFF switch, shown in Figure 12, in the **OFF** position (press **O**).

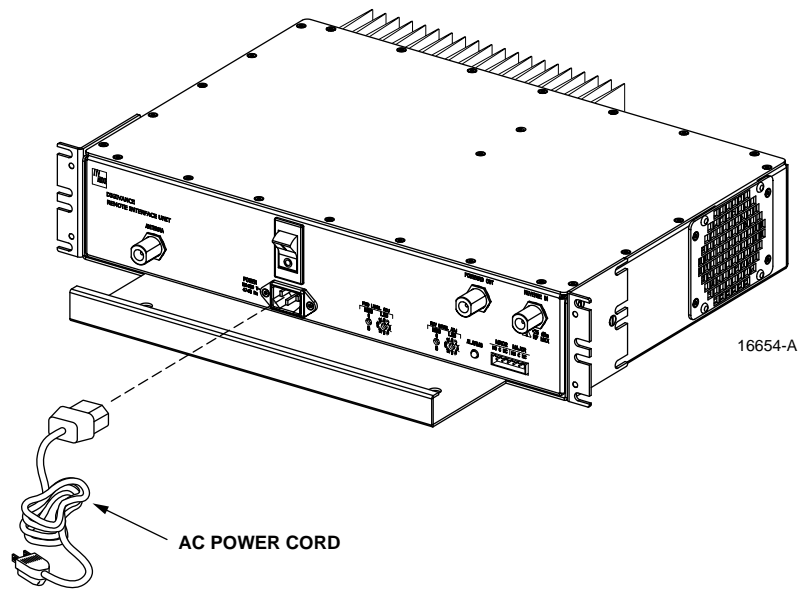

Figure 12. AC Power Connection

2. Locate the AC power cord which is provided separately with the RIU. Use only the AC power cord provided with the RIU or an equivalent UL listed and CSA certified 3-conductor, 18 AWG cord terminated in a molded-on plug cap rated 125 V, 15 A with a minimum length of 6 feet (1.8 m).

► **Note:** The RIU is intended to be used with a 3-wire grounding type plug which has a grounding pin. Equipment grounding is to ensure safe operation. Do not defeat the grounding means. Verify RIU is reliably grounded when installed.

3. Connect the receptacle end of the power cord to the AC connector on the RIU.
4. Route the plug end of the power cord to the specified AC outlet (per the system design) and connect plug to outlet.



Warning: *The current rating of the RIU is 2 Amps at 120 VAC. Avoid overloading circuits which may cause damage to over-current protection devices and supply wiring.*

5. Dress and secure cable.
6. When the RIU installation is complete, refer to Section 3 of this manual for the unit turn-up and test procedures.

3 OPERATION

This section provides guidelines for turning-up the RIU, verifying that the RIU is operating properly, setting the forward and reverse path signal levels, and correcting any installation problems.

3.1 Tools and Materials

The following tools and materials are required in order to complete the procedures in this section:

- Portable spectrum analyzer or network analyzer
- Pencil or pen
- Writing pad

3.2 Turn-Up Unit and Verify Operation

The process of turning-up the RIU and verifying operation involves setting the forward and reverse path signal levels, turning on the power, verifying that the LED indicator shows normal operation, and then measuring the forward and reverse path signal levels. Refer to Table 3 for a detailed description of the ALARM LED indicator.

Table 3. Remote Interface Unit LED Indicator

INDICATOR	COLOR	DESCRIPTION
ALARM		Indicates if the RIU is normal or if a fault is detected.
	Green	RIU in normal state, no faults detected.
	Yellow	High temperature fault detected. (Minor alarm)
	Red	Over or undercurrent fault on power amplifier detected. (Major alarm)
	Off	AC power off or RIU internal fault.

Use the following procedure to power-up the system:

1. Temporarily disconnect the alarm system or notify the alarm system provider that testing is in progress.
 2. Adjust the forward and reverse path signal levels as specified in sections 3.3 and 3.4.
 3. Verify that the donor antenna is properly installed and connected.
- **Note:** To comply with Maximum Permissible Exposure (MPE) requirements, antennas must be installed to provide at least **20 centimeters** (8 inches) of separation from all persons per FCC 47 CFR part 2.1091.
4. Verify that the RIU is connected to the appropriate AC outlet.
 5. Place the ON/OFF switch on the RIU in the ON position (press I).
 6. Verify that the ALARM LED on the RIU turns green.
 7. Check the forward path RF signal level at the DHU RF IN port and verify that the DHU input signal level is **-20 dBm**. Re-adjust FWD LEVEL ADJ rotary switches to add or remove gain if required.

8. Check the reverse path RF signal level at the antenna and verify that the signal level is correct per the system design. Re-adjust REV LEVEL ADJ rotary switches to add or remove gain if required.
9. Reconnect the alarm system or notify the alarm system provider that testing is complete.

3.3 Forward Path Level Adjustment

The level of the composite RF output signal from the donor antenna will vary depending on the gain of the antenna and the number of channels present. To interface with the DHU, the forward path signal level must be adjusted to provide a **-20 dBm** composite (maximum) input signal to the DHU. Use the following procedure to adjust the RIU to provide the required forward path signal level at the DHU:

1. Connect a spectrum analyzer or power meter to the antenna connector. The required signal levels and test points are shown in Figure 13.

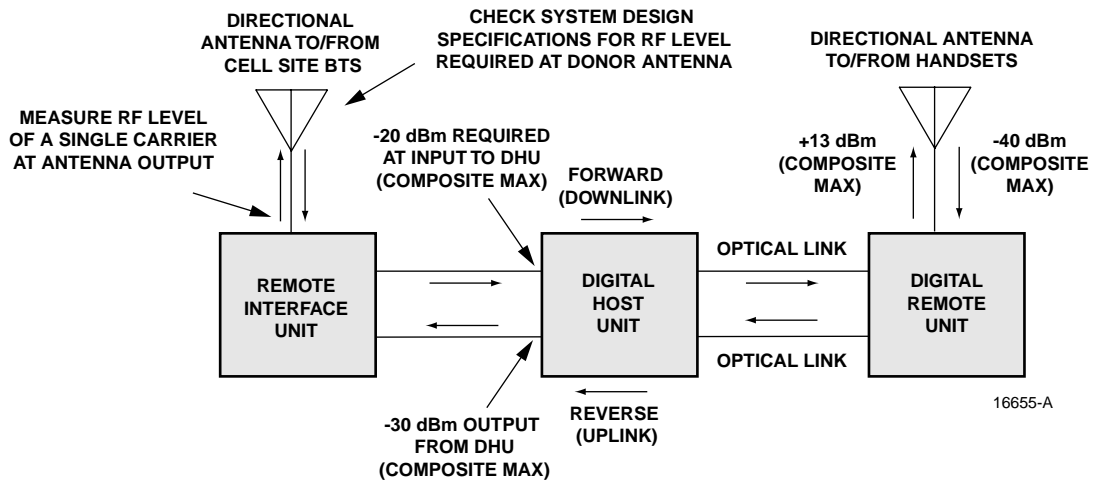

Figure 13. Signal Levels and Test Points

2. Measure the RF level of a single carrier, such as the control channel, in dBm. Make sure the resolution bandwidth of the spectrum analyzer or power meter is narrow enough to measure the power of the single 30 kHz channel only.
3. Verify that all carriers are coming in at equal power at bandwidth.
4. Calculate the total composite signal output power from the antenna using the following formula:

$$P_{tot} = P_c + 10 \text{ Log} N$$

Where,

P_{tot} is the total composite power in dBm

P_c is the power per carrier in dBm as measured in step 2, and

N is the total number of channels.

5. Determine the total cable loss that is imposed by the coaxial cable that links the antenna to the RIU and by the forward path coaxial cable that links the RIU to the DHU.
6. Subtract the total cable loss from the total composite power calculated in step 4.
7. Subtract -20 (the composite maximum input signal level required at the DHU) from the amount determined in step 6. The difference equals the total amount of gain required to raise the forward path signal level to the -20 dBm level required by the DHU. The result should be negative which indicates that gain is required. The following formula outlines the required calculations:

$$P_{\text{tot}} - CL_{\text{tot}} - (-20) = \text{Amount of gain (should be negative) required.}$$

Where;

P_{tot} is the total composite power in dBm (step 4)

CL_{tot} is the total cable loss (step 5)

-20 is the composite maximum input signal level required at the DHU

8. Using a small screwdriver, adjust the FWD LEVEL ADJ rotary switches to insert the gain required (as determined in step 7) to provide a -20 dBm signal at the DHU. Refer to Figure 14 for a description of how the rotary switches work and to Table 4 for the adjustment settings.

Note: The RIU provides a forward path signal adjustment range of from $+9$ dB to $+40$ dB.

9. Disconnect the spectrum analyzer or power meter from the antenna.

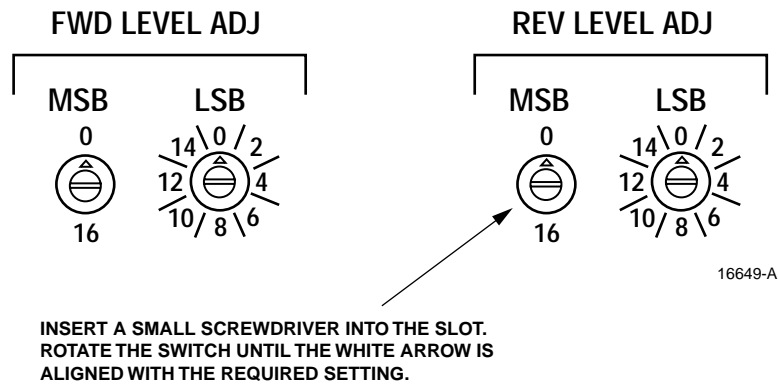

Figure 14. Rotary Switch Adjustment

Table 4. RIU Rotary Switch Adjustment Settings

REVERSE GAIN SETTINGS			FORWARD GAIN SETTINGS		
GAIN (+dB)	MSB SETTING	LSB SETTING	GAIN (+dB)	MSB SETTING	LSB SETTING
59	0	0	40	0	0
58	0	1	39	0	1
57	0	2	38	0	2
56	0	3	37	0	3
55	0	4	36	0	4
54	0	5	35	0	5
53	0	6	34	0	6
52	0	7	33	0	7
51	0	8	32	0	8
50	0	9	31	0	9
49	0	10	30	0	10
48	0	11	29	0	11
47	0	12	28	0	12
46	0	13	27	0	13
45	0	14	26	0	14
44	0	15	25	0	15
43	16	0	24	16	0
42	16	1	23	16	1
41	16	2	22	16	2
40	16	3	21	16	3
39	16	4	20	16	4
38	16	5	19	16	5
37	16	6	18	16	6
36	16	7	17	16	7
35	16	8	16	16	8
34	16	9	15	16	9
33	16	10	14	16	10
32	16	11	13	16	11
32	16	12	12	16	12
30	16	13	11	16	13
28	16	14	10	16	14
28	16	15	9	16	15

3.4 Reverse Path Level Adjustment

The level of the composite RF signal that should be input to the antenna will vary depending on the maximum acceptable DRU path loss per the system design. The design objective is for the Digivance system to provide unity gain. Use the following procedure to adjust the RIU to provide the required reverse path signal level at the antenna:

1. Determine the maximum acceptable DRU path loss per the system design specifications.
2. Determine the total gain provided by the DRU antenna and the donor antenna.
3. Determine the total cable loss that is imposed by the reverse path coaxial cable that links the DHU to the RIU and the coaxial cable that links the RIU to the antenna.
4. Calculate the total gain that must be added by the RIU using the following formula:

$$\text{RIU Gain} = \text{DRU path loss} + \text{Cable loss} - \text{DHU gain (10 dB)} - \text{Antenna Gain}$$

The result should be negative which indicates that gain is required.

5. Using a small screwdriver, adjust the REV LEVEL ADJ rotary switches to insert the gain required as determined in step 4. Refer to Figure 14 for a description of how the rotary switches work and to Table 4 for the adjustment settings.

Note: The RIU provides a reverse path signal adjustment range of from +28 dB to +59 dB.

4 MAINTENANCE

This section explains the alarm reporting system, provides a method for isolating and troubleshooting faults, and provides procedures for replacing the cooling fan.

The RIU requires no regular maintenance to insure continuous and satisfactory operation. Maintenance, as it applies to the RIU, primarily involves diagnosing and correcting service problems as they occur. When an alarm is reported, it will be necessary to follow a systematic troubleshooting procedure to locate the problem. Once the source of the problem is isolated, the appropriate corrective action can be taken to resolve the problem. The only component that can be replaced is the cooling fan. The failure of any other component within the RIU requires replacement of the RIU.

4.1 Tools and Materials

The following tools and materials are required in order to complete the procedures in this section:

- ESD wrist strap
- Small size flat-bladed screwdriver
- TORX screwdriver (T10)

4.2 Fault Detection and Alarm Reporting

Detection of a fault by the RIU generates an external alarm response. An ALARM LED indicator is provided on the RIU front panel to visually indicate when a fault is detected. In addition, normally open (NO) and normally closed (NC) dry alarm contacts are provided to report **minor** and **major** alarms to an **external** alarm system. A minor alarm is defined as a high temperature condition. A major alarm is defined as a power amplifier over/undercurrent condition.

When the RIU alarm contacts are connected to an external alarm system, detection of a fault will generate an alarm at the Network Operations Center (NOC). Whenever a problem is reported, refer to Table 5 to isolate and correct the fault.

Table 5. Fault Isolation and Troubleshooting

Alarm Type: Minor	
ALARM Indicator: Yellow:	
POSSIBLE CAUSE	CORRECTIVE ACTION/COMMENTS
1. Air intake or exhaust openings to RIU chassis blocked.	1. Remove cause of air-flow blockage.
2. Ambient temperature > 58° C/136° F.	2. Reduce ambient temperature.
3. Faulty fan.	3. Replace fan (see Subsection 4.3).

Continued

Table 5. Fault Isolation and Troubleshooting, Continued

Alarm Type: Major	
ALARM Indicator: Red:	
POSSIBLE CAUSE	CORRECTIVE ACTION/COMMENTS
1. Over or undercurrent condition detected at power amplifier	1. Replace RIU.
Alarm Type: Major	
ALARM Indicator: Off:	
POSSIBLE CAUSE	CORRECTIVE ACTION/COMMENTS
1. AC power source off or disconnected.	1. Restore AC power.
2. Faulty RIU	2. Replace RIU.

4.3 Fan Replacement

It is recommended that the fan (catalog number DGVI-200000FAN) be replaced every five years. Replacement of a fan requires that the RIU be turned off for a short period of time. This will drop all existing calls, cause a temporary loss of service, and generate a major alarm. Use the following procedure to replace the RIU cooling fan:

1. Before touching the RIU or handling a fan, slip on an Electro-Static Discharge (ESD) wrist strap and connect the ground wire to an earth ground source. Wear the ESD wrist strap while completing each section of the fan installation procedure.



Warning: *Electronic components can be damaged by static electrical discharge. To prevent ESD damage, always wear an ESD wrist strap when working on the RIU and when handling electronic components.*

2. Notify the NOC or alarm monitoring system operator that the system is going offline.
3. Place the RIU AC power On/Off switch in the OFF position (press **O**) and disconnect the AC power cord.



Caution: *High voltage components are present within the RIU enclosure. Disconnect the AC power cord from the AC power source before proceeding to step 4.*

4. Remove the four flat-head screws (requires TORX screwdriver with T15 bit) that secure the fan/grill assembly to the side of the enclosure as shown in Figure 15 and save for reuse.
5. Carefully withdraw the fan/grill assembly from the enclosure until the wiring harness is exposed and the connector is accessible.
6. Lift the small latch on the wiring harness connector (see Figure 15) and carefully unplug the connector from the circuit board connector.
7. Remove the four plastic rivets that secure the faulty fan to the grill by pushing outward on rivet center post until the rivet can be withdrawn from the grill as shown in Figure 16.
8. Remove the fan from the grill and then locate the replacement fan.
9. Use the rivets removed in step 7 to secure the replacement fan to the grill. Orient the fan so the wiring harness is on the **right side** (side of fan that faces toward back of enclosure when installed) and the arrow on the fan housing faces into the enclosure.

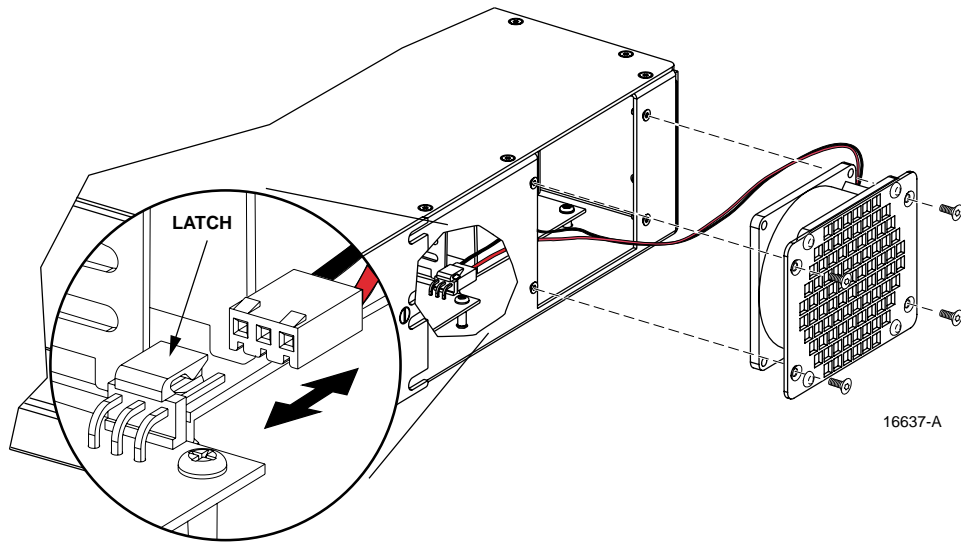

Figure 15. Fan/Grill Assembly Removal

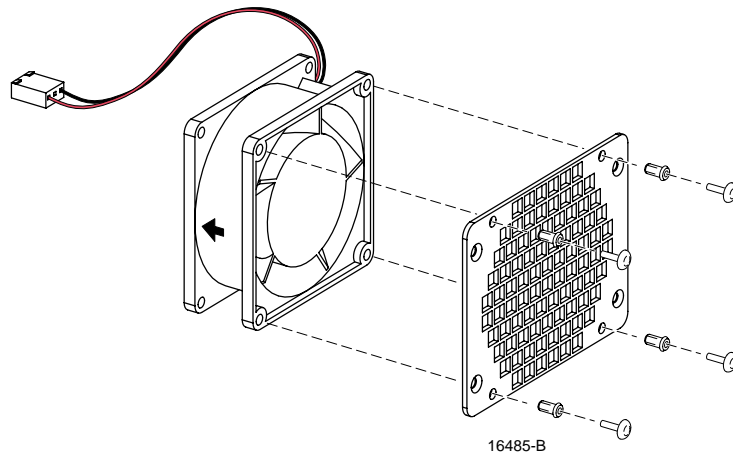

Figure 16. Removing Fan From Grill

10. Connect the wiring harness connector to the circuit board connectors.
11. Route the wiring harness under the fan.
12. Secure the fan/grill assembly to the side of the enclosure (see Figure 15) using the four flat-head screws removed in step 4.
13. Reconnect the AC power cord and place the RIU AC power On/Off switch in the ON position (press **I**).
14. Verify that the fan runs properly following power up.
15. Notify the NOC or alarm monitoring system operator that the system is going back online.

5 CUSTOMER INFORMATION AND ASSISTANCE

For customers wanting information on ADC products or help in using them, ADC offers the services listed below. To obtain any of these services by telephone, first dial the central ADC telephone number, then dial the extension provided below.

The central number for calls originating in the U.S.A. or Canada is **1-800-366-3891**. For calls originating outside the U.S.A. or Canada, dial country code “1” then dial **952-946-3000**.

Sales Assistance Extension 63000	<ul style="list-style-type: none"> • Quotation Proposals • Ordering and Delivery • General Product Information
Systems Integration Extension 63000	<ul style="list-style-type: none"> • Complete Solutions (from Concept to Installation) • Network Design and Integration Testing • System Turn-Up and Testing • Network Monitoring (Upstream or Downstream) • Power Monitoring and Remote Surveillance • Service/Maintenance Agreements • Systems Operation
BCG Technical Assistance Center Extension 63475 E-Mail: bcg_tac@adc.com	<ul style="list-style-type: none"> • Technical Information • System/Network Configuration • Product Specification and Application • Training (Product-Specific) • Installation and Operation Assistance • Troubleshooting and Repair
Product Return Department Extension 63748 E-Mail: repair&return@adc.com	<ul style="list-style-type: none"> • ADC Return Authorization number and instructions must be obtained before returning products.

Product information may also be obtained using the ADC web site at **www.adc.com** or by writing ADC Telecommunications, Inc., P.O. Box 1101, Minneapolis, MN 55440-1101, U.S.A.

Contents herein are current as of the date of publication. ADC reserves the right to change the contents without prior notice. **In no event shall ADC be liable for any damages resulting from loss of data, loss of use, or loss of profits and ADC further disclaims any and all liability for indirect, incidental, special, consequential or other similar damages. This disclaimer of liability applies to all products, publications and services during and after the warranty period.**

This publication may be verified at any time by contacting ADC's Technical Assistance Center at 1-800-366-3891, extension 63475 (in U.S.A. or Canada) or 952-946-3475 (outside U.S.A. and Canada), or by e-mail to bcg_tac@adc.com.

