

2. Right-click on the **Host Fwd Delay** section of the display (see [Figure 4-14](#)). The **Host Fwd Delay** pop-up screen will open as shown in [Figure 4-15](#).
3. Obtain the value of the forward delay as specified in the system design plan. The delay is adjustable in 0.1 μ sec steps.
4. Enter the forward path delay value and click OK to close the pop-up screen and to make the changes take effect.
5. Repeat the process for reverse delay and diversity reverse delay by right-clicking on the appropriate delay section (see [Figure 4-14](#)) and then entering the required delay value in the pop-up screen.
6. Click OK to close each pop-up screen and to make the changes take effect.



Figure 4-15. Host Fwd Delay Pop-Up Screen

SECTION 5: MAINTENANCE

1	SYSTEM MAINTENANCE OVERVIEW	5-1
1.1	Tools and Materials	5-1
2	FAULT DETECTION AND ALARM REPORTING	5-2
3	FAULT ISOLATION AND TROUBLESHOOTING	5-5
3.1	Host Unit Troubleshooting	5-6
3.2	STM Troubleshooting	5-8
3.3	LPA Troubleshooting	5-10
4	TEST PROCEDURES	5-11
4.1	Optical Power Test	5-11
4.2	Optical Loopback Test	5-12
5	MAINTENANCE PROCEDURES	5-14
5.1	Scheduled Maintenance	5-14
5.2	Remote Unit Outdoor Cabinet Filter Cleaning Procedure	5-14
5.3	Host Unit Fan Replacement Procedure	5-15
5.4	Spectrum Transport Module Fan Replacement Procedure	5-17
5.5	Linear Power Amplifier Fan Replacement Procedure	5-19

1 SYSTEM MAINTENANCE OVERVIEW

This section explains the Digivance system fault detection and alarm reporting system, provides a method for isolating and troubleshooting faults, and provides test and maintenance procedures. The Digivance system requires minimal regular maintenance to insure continuous and satisfactory operation. Components that require regular replacement, cleaning, or testing include the HU and RU fans and the RU outdoor cabinet air-filter.

Maintenance also includes diagnosing and correcting service problems as they occur. When an alarm is reported, it will be necessary to follow a systematic troubleshooting procedure to locate the problem. Once the source of the problem is isolated, the appropriate corrective action can be taken to restore service. The only internal components that can be replaced are the cooling fans which mount in the HU, RU, and LPA. The failure of any other component within a unit will require replacement of that unit.

1.1 Tools and Materials

The following tools and materials are required in order to complete the procedures in this section:

- ESD wrist strap
- IR filtering safety glasses
- Patch cords with SC connectors
- 15 dB in-line SC optical attenuators

- Optical power meter (1550 and 1310 nm)
- TORX screwdriver (with T10 bit)

2 FAULT DETECTION AND ALARM REPORTING

The Digivance system on-board embedded software detects various unit and system faults and reports them as either Major or Minor alarms. A Major alarm indicates that the system has failed in a way that directly affects RF transport performance. This usually means that some calls or perhaps all calls cannot be made over the system. A Minor alarm means that system performance is not affected or in some cases, that the performance may no longer be optimal. Four types of faults cause a minor alarm to be reported: overtemperature, fan failure, diversity path failure, and an external minor fault (user defined fault). All other faults are reported as a Major alarm.

Reporting of Major and Minor alarms is accomplished through the HU alarm contacts, the unit front panel LED's, the EMS software Graphical User Interface (GUI), and the Network Operations Center - Network Element Manager (NOC/NEM) interface.

The HU is equipped with a set of both normally open (NO) and normally closed (NC) alarm contacts which are used to report both Major and Minor alarms to an external alarm system. The alarm contacts summarize the inputs so that any Major or Minor alarm will trigger an alarm report to the external alarm system.

The HU, STM, and LPA front panel LED indicators are used to report specific alarms which are reflected in the LED colors: Green, Red, Yellow, and Off. A description of the Host Unit, Linear Power Amplifier, and Spectrum Transport Module LED indicators is provided respectively in [Table 5-1](#), [Table 5-2](#), and [Table 5-3](#).

The EMS software GUI provides both a summary and a more detailed list of alarm information that includes unit and module level faults, circuit faults, and measured value faults such as voltages, RF power, and temperature. A summary showing a list of all systems and their current alarm status is presented through the Alarm OverView display. A detailed list of alarm information is presented through the HOST alarm display and the REMOTE alarm display. All the inputs that the system reports as alarms are shown in the HOST and REMOTE alarm displays.

The NOC/NEM interface provides the same summary and detailed list of alarm information as the EMS software GUI but in an ASCII text string format. Sending the command GET ALARM SUMMARY produces a list of all systems and their current alarm status. Sending the command GET ALARM ALL for a specific system will produce a detailed list of alarm information for the specified system.

Table 5-1. Host Unit LED Indicators

INDICATOR	COLOR	DESCRIPTION
POWER	Green Off	Indicates if the HU is powered or un-powered. The DC power source is on. The DC power source is off.
STANDBY	Green (blinking) Yellow (blinking) Red (blinking) Off	Indicates if the system is in the standby, normal, test, or program load mode. The HU is in the standby mode. The HU is in the program load mode. The HU is in the test mode. The HU is in the normal mode.
HOST UNIT	Green Yellow Red	Indicates if the HU is normal, over temperature, or if a fault is detected. The HU is normal. High temperature detected in HU. Fault detected by the HU or HU/RU band mismatch.
REMOTE UNIT	Green Yellow Red	Indicates if an alarm is detected at the RU. No alarms detected at the RU. A minor alarm is detected at the RU. A major alarm is detected at the RU.
DRIVE	Green Yellow Red	Indicates if the forward path RF signal level is normal, above overdrive threshold, or below underdrive threshold. The RF signal level is normal The RF signal level is below the underdrive threshold. The RF signal level is above the overdrive threshold.
PORT 1/PORT 2	Green Red	Indicates if the reverse/forward path optical signals from the STM/HU are normal, if errors are detected, or if the optical signal is not detected. The reverse/forward path optical signal is normal. Excessive errors (see Note) are detected in the reverse or forward path optical signals or the HU or STM is not receiving a forward or reverse path optical signal.

Note: Excessive errors mean the Bit Error Rate (BER) has exceeded 10^{-6} (1 bit error per million bits)

Table 5-2. Linear Power Amplifier LED Indicator

INDICATOR	COLOR	DESCRIPTION
STATUS	Green (blinking) Green Yellow (blinking) Yellow Red	Indicates the operational state of the LPA and whether or not any faults are detected. The LPA is in the normal state. The LPA is in a forced shutdown state, no faults detected. The LPA is in the normal state, minor fault detected. The LPA is initializing. The LPA is in an internal shutdown state, major fault detected.

Table 5-3. Spectrum Transport Module LED Indicators

INDICATOR	COLOR	DESCRIPTION
AC POWER	Green Red	Indicates if the STM is powered by the AC power source or the back-up battery system. The STM is powered by the AC power source. The STM is powered by the back-up battery system.
STANDBY	Green (blinking) Yellow (blinking) Red (blinking) Off	Indicates if the system is in the standby, normal, test, or program load mode. The STM is in the standby mode. The STM is in the program load mode. The STM is in the test mode. The STM is in the normal mode.
HOST UNIT	Green Yellow Red	Indicates if an alarm is detected at the HU. No alarms detected at the HU. A minor alarm is detected at the HU. A major alarm is detected at the HU.
STM	Green Yellow Red	Indicates if the STM is normal, over temperature, or if a fault is detected. The STM is normal. The STM is over temperature due to high ambient temperature or the fan has failed. Fault detected by the STM or HU/RU band mismatch.
PA	Green Yellow Red	Indicates if the LPA is normal, over temperature, has a fan failure, or is faulty. The LPA is normal. The LPA is over temperature or the fan has failed. Internal fault detected in the LPA.
VSWR	Green Red	Indicates if the forward path VSWR is above or below the threshold. The VSWR is below the threshold. The VSWR is above the threshold.
PORT 1/PORT 2	Green Red	Indicates if the forward/reverse path optical signals from the HU/STM are normal, if errors are detected, or if the optical signal is not detected. The forward/reverse path optical signal is normal. Excessive errors (see Note) are detected in the forward or reverse path optical signals or the STM or HU is not receiving a forward or reverse path optical signal.

Note: Excessive errors mean the Bit Error Rate (BER) has exceeded 10^{-6} (1 bit error per million bits)

3 FAULT ISOLATION AND TROUBLESHOOTING

Alarm information may be accessed and faults isolated using the information provided by the unit front panel LED indicators, the EMS software GUI alarm displays, or the NOC-EMS interface. Because the alarm information provided by the EMS GUI and the NOC-EMS interface is very detailed, refer to [Table 5-4](#), [Table 5-5](#), or [Table 5-6](#) to determine the unit LED indicator (Host Unit, Remote Unit, or LPA) that corresponds to the indicated alarm. Then refer to [Table 5-7](#), [Table 5-8](#), or [Table 5-9](#) to identify the problem, check out the possible causes, and take corrective action.

Table 5-4. Host Unit Major and Minor Alarms

MAJOR ALARM	LED INDICATOR	MAJOR ALARM	LED INDICATOR
Operating Mode	STANDBY	Fwd Synth Lock	HOST UNIT
8 Volt	HOST UNIT	RF Mute	(Does not apply)
Pri No Light	PORT 1/PORT 2	Major Extern Output	(Does not apply)
Pri Fwd Mux Lock	HOST UNIT	Companion Lost	(Does not apply)
Pri Rev Synth Lock	HOST UNIT	MINOR ALARMS	LED INDICATOR
Overdrive	DRIVE	Temperature	HOST UNIT
Unit Mismatch	HOST UNIT	Sec No Light	(Does not apply)
Link Alarm	(Does not apply)	Sec Errors	(Does not apply)
3.8 Volt	HOST UNIT	Sec Rev Synth Lock	(Does not apply)
Pri Laser Fail	HOST UNIT	Underdrive	DRIVE
Pri Errors	PORT 1/PORT 2	Minor Extern Output	(Does not apply)

Table 5-5. Remote Unit Major Alarms

MAJOR ALARM	LED INDICATOR	MAJOR ALARM	LED INDICATOR
Operating Mode	STANDBY	Battery Voltage	(Does not apply)
3.8 Volt	STM	Pri Laser Fail	STM
Pri Errors	PORT 1/PORT 2	Fwd Synth Lock	STM
Reference Synth Lock	STM	System VSWR	VSWR
LPA DC Fail	PA	LPA Low Power	PA
LPA VSWR	PA	Unit Mismatch	STM
Link Alarm	(Does not apply)	Converter	STM
AC Fail	AC POWER	Pri No Light	PORT 1/PORT 2
8 Volt	STM	Pri Rev Synth Lock	STM
Pri Rev Mux Lock	STM	LPA Detect	PA
RF Mute	(Does not apply)	LPA Over Power	PA
LPA Loop Failed	PA	Companion Lost	(Does not apply)
Major Extern Alarm Inp	(Does not apply)	–	–

Table 5-6. Remote Unit Minor Alarms

MINOR ALARM	LED INDICATOR	MINOR ALARM	LED INDICATOR
Temperature	STM	Sec Laser Fail	(Does not apply)
Sec Rev Mux Lock	(Does not apply)	Sec Rev Synth Lock	(Does not apply)
Rev Path Level	(Does not apply)	LPA Disable	STATUS (LPA)
LPA Fan	PA	LPA High Temp	PA
Minor Extern Alarm Inp	(Does not apply)	RF Out Very Low	(Does not apply)

3.1 Host Unit Troubleshooting

During normal HU operation, all LED's should be **green** except the STANDBY LED which should be **Off**. When a **Minor** alarm occurs, one or more of the LED's will turn **yellow**. When a **Major** alarm occurs, one or more of the LED's will turn **red**.

It is recommended that whenever there are multiple alarms, the optical alarms should be checked and cleared first. Because the host and remote units function as a system, a fault in the fiber optic link will cause various unit alarms to be reported.

Table 5-7. Host Unit Fault Isolation and Troubleshooting

LED: POWER	Color: Off	Alarm Type: Major
PROBLEM: The HU is not powered.		
POSSIBLE CAUSE		CORRECTIVE ACTION/COMMENTS
1. The fuse is open or removed from the fuse panel.		1. Replace or reinstall fuse at fuse panel.
LED: STANDBY	Color: Green (blinking) or Yellow (blinking)	Alarm Type: None
PROBLEM: The HU is out of service.		
POSSIBLE CAUSE		CORRECTIVE ACTION/COMMENTS
1. The HU is in the standby (green) or program load (yellow) mode.		1. Use EMS to place the HU in the normal (off) mode.
LED: HOST UNIT	Color: Yellow	Alarm Type: Minor
PROBLEM: The HU is overheating.		
POSSIBLE CAUSE		CORRECTIVE ACTION/COMMENTS
1. Air intake or exhaust opening to HU chassis is blocked		1. Remove cause of air-flow blockage.
2. Ambient temperature > 50° C/122° F.		2. Reduce ambient temperature.
3. Faulty fan.		3. Replace HU fan (See Section 5.3).

Table 5-7. Host Unit Fault Isolation and Troubleshooting, continued

LED: HOST UNIT	Color: Red	Alarm Type: Major
PROBLEM: A major alarm fault detected by HU.		
POSSIBLE CAUSE	CORRECTIVE ACTION/COMMENTS	
1. Fiber optic link fault.	1. Follow procedure specified when the PORT 1 / PORT 2 LED is red.	
2. HU and STM band mismatch.	2. Replace HU or STM with correct unit.	
3. The HU has failed.	3. Replace the HU.	
LED: REMOTE UNIT	Color: Yellow	Alarm Type: Minor
PROBLEM: A minor alarm fault is detected at the RU.		
POSSIBLE CAUSE	CORRECTIVE ACTION/COMMENTS	
1. The STM or LPA is overheating.	1. Check RU LED indicators and refer to Table 5-8	
LED: REMOTE UNIT	Color: Red	Alarm Type: Major
PROBLEM: A major alarm fault is detected at the RU.		
POSSIBLE CAUSE	CORRECTIVE ACTION/COMMENTS	
1. Fiber optic link fault.	1. Check RU LED indicators and refer to Table 5-8 .	
2. AC power failure at RU.	2. Check RU LED indicators and refer to Table 5-8 .	
3. High VSWR.	3. Check RU LED indicators and refer to Table 5-8 .	
4. The RU cabinet door is open or the STM or LPA has failed.	4. Check RU LED indicators and refer to Table 5-8 .	
LED: DRIVE	Color: Yellow	Alarm Type: Minor
PROBLEM: The RF input signal level is below the underdrive threshold.		
POSSIBLE CAUSE	CORRECTIVE ACTION/COMMENTS	
1. Faulty BTS or faulty coaxial connection between the HU and the BTS.	1. Check forward path signal level at the HU.	
2. Incorrect attenuation in forward path RF coaxial link.	2. Check Host Forward Attenuator setting and adjust if attenuation is too high.	
LED: DRIVE	Color: Red	Alarm Type: None
PROBLEM: The RF signal is above the overdrive threshold.		
POSSIBLE CAUSE	CORRECTIVE ACTION/COMMENTS	
1. Composite output signal level from BTS is too high.	1. Check BTS composite output signal level and adjust if too high.	
2. Incorrect attenuation in forward path RF coaxial link.	2. Check Forward Attenuator setting and adjust if attenuation is too low.	
LED: PORT 1/PORT 2	Color: Red	Alarm Type: Major
PROBLEM: Excessive errors are detected in the reverse or forward path optical signal or no forward or reverse path optical signal is detected.		
POSSIBLE CAUSE	CORRECTIVE ACTION/COMMENTS	
1. Faulty reverse or forward path optical fiber.	1. Test optical fiber. Clean connector if dirty. Repair or replace optical fiber if faulty. (See Section 4.1).	
2. Faulty optical transmit port at the STM or HU; or faulty optical receive port at the STM or HU.	2. Test optical ports. Replace HU or STM if port is faulty (See Section 4.2).	

3.2 STM Troubleshooting

During normal STM operation, all LED's should be green except the STANDBY LED which should be **Off**. When a **Minor** alarm occurs, one or more of the LED's will turn **yellow**. When a **Major** alarm occurs, one or more of the LED's will turn **red**.

It is recommended that whenever there are multiple alarms, the optical alarms should be checked and cleared first. Because the host and remote units function as a system, a fault in the fiber optic link will cause various unit alarms to be reported.

Table 5-8. STM Fault Isolation and Troubleshooting

LED: AC POWER	Color: Off	Alarm Type: Major
PROBLEM: The RU is powered by the battery back-up system.		
POSSIBLE CAUSE		CORRECTIVE ACTION/COMMENTS
1. The AC power system circuit breaker is open or the AC power has failed.		1. Check the AC power system, repair as needed, and reset circuit breaker.
2. The STM has failed.		2. Replace the STM.
LED: STANDBY	Color: Green (blinking) or Yellow (blinking)	Alarm Type: None
PROBLEM: The RU is out of service.		
POSSIBLE CAUSE		CORRECTIVE ACTION/COMMENTS
1. The RU is in the standby (green) or program load (yellow) mode.		1. Use EMS to place the RU in the normal (off) mode.
LED: HOST UNIT	Color: Yellow	Alarm Type: Minor
Problem: A minor alarm fault is detected at the HU.		
POSSIBLE CAUSE		CORRECTIVE ACTION/COMMENTS
1. The HU is overheating.		1. Check HU LED indicators and refer to Table 5-7
LED: HOST UNIT	Color: Red	Alarm Type: Major
PROBLEM: A major alarm fault is detected at the HU.		
POSSIBLE CAUSE		CORRECTIVE ACTION/COMMENTS
1. Fiber optic link fault.		1. Check HU LED indicators and refer to Table 5-7 .
2. The HU is not powered.		2. Check HU LED indicators and refer to Table 5-7 .
3. The HU has failed.		3. Check HU LED indicators and refer to Table 5-7 .
LED: STM	Color: Yellow	Alarm: Minor
PROBLEM: The STM is overheating.		
POSSIBLE CAUSE		CORRECTIVE ACTION/COMMENTS
1. Air intake or exhaust opening to the remote unit cabinet is blocked		1. Remove cause of air-flow blockage.
2. Ambient temperature > 50° C/122° F.		2. Reduce ambient temperature.
3. Faulty fan.		3. Replace STM fan (See Section 5.4).

Table 5-8. STM Fault Isolation and Troubleshooting, continued

LED: STM	Color: Red	Alarm Type: Major
PROBLEM: A major alarm fault detected by the STM.		
POSSIBLE CAUSE	CORRECTIVE ACTION/COMMENTS	
1. Fiber optic link fault.	1. Follow procedure specified when the PORT 1/ PORT 2 LED is red.	
2. The HU is not powered.	2. Check HU LED indicators and refer to Table 5-7	
3. HU and STM band mismatch.	3. Replace HU or STM with correct unit.	
4. The STM has failed.	4. Replace the STM.	
LED: PA	Color: Yellow	Alarm Type: Minor
PROBLEM: The LPA is overheating.		
POSSIBLE CAUSE	CORRECTIVE ACTION/COMMENTS	
1. Air intake or exhaust opening to the remote unit cabinet is blocked	1. Remove cause of air-flow blockage.	
2. Ambient temperature > 50° C/122° F.	2. Reduce ambient temperature.	
3. Faulty LPA fan.	3. Replace LPA fan (See Section 5.5).	
LED: PA	Color: Red	Alarm Type: Major
PROBLEM: The LPA is not detected, the RF power is low or not present, or the LPA detects a major alarm.		
POSSIBLE CAUSE	CORRECTIVE ACTION/COMMENTS	
1. The LPA is not present.	1. Install LPA.	
2. The LPA RF output is turned off.	2. Place LPA MUTE/NORM/RESET switch in the NORM position.	
3. The forward path RF cables or connectors are faulty.	3. Inspect cables and connectors and repair or replace if faulty.	
4. The LPA is in the forced shutdown state.	4. Check LPA display for messages and then refer to Table 5-9 . Replace the LPA if it is faulty.	
5. The LPA is losing gain due to an internal fault.	5. Replace LPA.	
6. The STM duplexer has failed.	6. Replace the STM.	
LED: VSWR	Color: Red	Alarm Type: Major
PROBLEM: The forward path VSWR is above the threshold.		
POSSIBLE CAUSE	CORRECTIVE ACTION/COMMENTS	
1. Faulty antenna or antenna system.	1. Check the antenna circuit for shorts or opens (including lightning protector).	
2. Faulty antenna cable.	2. Check the antenna cable for faulty connections.	
3. The STM has failed.	3. Replace the STM.	
LED: PORT 1/PORT 2	Color: Red	Alarm Type: Major
PROBLEM: Excessive errors are detected in the reverse or forward path optical signal or no forward or reverse path optical signal is detected.		
POSSIBLE CAUSE	CORRECTIVE ACTION/COMMENTS	
1. Faulty forward or reverse path optical fiber.	1. Test optical fiber. Clean connector if dirty. Repair or replace optical fiber if faulty. (See Section 4.1).	
2. Faulty optical transmit port at the HU or STM; or faulty optical receive port at the HU or STM.	2. Test optical ports. Replace HU or STM if port is faulty (See Section 4.2).	

3.3 LPA Troubleshooting

During normal LPA operation, the STATUS LED should be **blinking green** (normal operation) or **blinking yellow** (minor fault).

Table 5-9. LPA Fault Isolation and Troubleshooting

LED: STATUS	Color: Green	Alarm Type: None
PROBLEM: The LPA is in the forced shutdown state.		
POSSIBLE CAUSES		
1. The MUTE/NORM/RESET switch is in the MUTE position.	1. Place MUTE/NORM/RESET switch in the NORM position.	
2. The Digivance system is in the STANDBY mode.	2. Use EMS to change Digivance system from standby mode to the normal mode.	
LED: STATUS	Color: Yellow (blinking)	Alarm Type: Minor
PROBLEM: The LPA detects a minor fault.		
POSSIBLE CAUSE		CORRECTIVE ACTION/COMMENTS
1. The LPA fan has failed but unit not overheated.		1. Replace LPA fan. (see Section 5.5)
LED: STATUS	Color: Red	Alarm Type: Major
PROBLEM: The LPA is in the internal shutdown state.		
POSSIBLE CAUSE		CORRECTIVE ACTION/COMMENTS
1. The interface cable between the LPA and STM is faulty, the antenna cable is faulty, the antenna or antenna system is faulty, or the STM duplexer is faulty (VSWR alarm).		1. Inspect cable, antenna, and connectors and repair or replace if faulty. Replace STM if duplexer is faulty. To reset, use EMS to place Digivance system in standby mode and then place system back in normal mode.
2. The power level of the RF forward path composite input signal at the HU is too high. (Over power alarm)		2. Check the power level of the RF composite input signal at the HU and adjust to correct level. To reset, use EMS to place Digivance system in standby mode and then place system back in normal mode.
3. The LPA fan has failed and unit has overheated. (High temp alarm)		3. Replace LPA fan. (see Section 5.5). To reset, use EMS to place Digivance system in standby mode and then place system back in normal mode.
4. Air intake or exhaust opening to RU outdoor cabinet is blocked causing unit to overheat. (High temp alarm)		4. Remove cause of air-flow blockage. To reset, use EMS to place Digivance system in standby mode and then place system back in normal mode.
5. RU ambient temperature > 50° C/122° F. (High temp alarm)		5. Reduce RU ambient temperature. To reset, use EMS to place Digivance system in standby mode and then place system back in normal mode.
6. The LPA is faulty. (VSWR, DC fail, Loop fail, or low power alarm)		6. Replace LPA.

4 TEST PROCEDURES

This section provides procedures for common troubleshooting and maintenance tests. Refer to these procedures as needed when specified in the Fault Isolation and Troubleshooting tables in [Section 3](#).

4.1 Optical Power Test

A break in an optical fiber or a fault with the optical connector will interrupt communications between linked components or generate excessive errors. Use the following procedure to isolate a problem with an optical fiber or connector.



Danger: *This equipment uses a Class 1 Laser according to FDA/CDRH rules. Laser radiation can seriously damage the retina of the eye. Do not look into the ends of any optical fiber. Do not look directly into the optical transmitter of any unit or exposure to laser radiation may result. An optical power meter should be used to verify active fibers. A protective cap or hood **MUST** be immediately placed over any radiating transmitter or optical fiber connector to avoid the potential of dangerous amounts of radiation exposure. This practice also prevents dirt particles from entering the connector.*

1. Put on the IR filtering safety glasses.
2. Notify the NOC or alarm monitoring system operator that the system is going offline.
3. At the HU **and** at the STM, place the On/Off switches in the **OFF** position (press **0**).
- ▶ **Note:** Turning off the HU and STM disables the respective lasers which is necessary in order to safely inspect and clean the optical connectors.
4. Disconnect the optical fiber connectors for the fiber to be tested at the HU **and** the STM.
5. Inspect the optical connectors. Verify that connectors are clean and that no scratches or imperfections are visible on the fiber end. Clean and polish the optical connectors if necessary.
6. Connect the optical power meter to the **output** (receiver) end of the optical fiber. If an attenuator was included in the fiber link, make sure the attenuator is installed.
7. Connect the **input** (transmitter) end of the optical fiber to the far end HU or STM.
8. At the **far** end HU or STM, place the On/Off switch in the **ON** position (press **1**).
9. Using the **far** end HU or STM as an optical light source, measure the optical power at the **near** end of the optical fiber. The power level of the optical input signal at the HU or STM must fall within the following ranges:

STM Forward Path Input Signal (Port 1): -15 to -25 dBm (with attenuator installed)

HU Reverse Path Input Signal (Port 2): -15 to -23 dBm (with attenuator installed)

If the power level of the received optical signal is within the specified range, the optical fiber and the far end unit are good. If the power level of the received signal is not within the specified range, either the optical fiber is faulty or the far end unit optical transmitter is faulty. Continue with test procedure to isolate the problem

10. At the **far** end HU or STM, place the On/Off switch in the **OFF** position (press **0**).
11. Disconnect the optical power meter from the **near** end of the optical fiber.
12. Connect the optical power meter to the **far** end HU (Port 1) or STM (Port 2).
13. At the **far** end HU or STM, place the On/Off switch in the **ON** position (press **1**).
14. Measure the optical output power of the **far** end HU or STM. The power level of the optical output signal from the HU or STM must meet the following specification:
 - HU Forward Path Output Signal (Port 1): 0 ± 1 dBm
 - STM Reverse Path Output Signal (Port 2): $+2 \pm 1$ dBm

If the power level of the optical output signal is within specifications, the optical fiber is faulty. If the power level of the optical signal is not within specifications, the far end HU or STM optical transmitter is faulty.
15. At the **far** end HU or STM, place the On/Off switch in the **OFF** position (press **0**).
16. Disconnect the optical power meter from the **far** end HU or STM.
17. Reconnect the optical fibers at the HU and the STM.
18. Repeat steps 3 through 17 for each optical fiber that requires testing.
19. When ready to put the system back into service, place the On/Off switch in the **ON** position (press **1**) at both the HU and STM.
20. Notify the NOC or alarm monitoring service that the system is going back online.

4.2 Optical Loopback Test

The following procedures provide tests to determine if an optical port fault exists with the Host Unit or with the STM.



Danger: *This equipment uses a Class 1 Laser according to FDA/CDRH rules. Laser radiation can seriously damage the retina of the eye. Do not look into the ends of any optical fiber. Do not look directly into the optical transmitter of any unit or exposure to laser radiation may result. An optical power meter should be used to verify active fibers. A protective cap or hood **MUST** be immediately placed over any radiating transmitter or optical fiber connector to avoid the potential of dangerous amounts of radiation exposure. This practice also prevents dirt particles from entering the connector.*

4.2.1 Host Loopback Test

1. Put on the IR filtering safety glasses.
2. Notify the NOC or alarm monitoring system operator that the system is going offline.
3. At the HU, place the On/Off switch in the **OFF** position (press **0**).
4. Disconnect the optical fiber connectors from the PORT 1 and PORT 2 optical ports and place a dust cap over each connector.

5. Plug a 15 dB in-line optical attenuator into the PORT 1 optical port.
6. Connect a patch cord between the optical attenuator and the PORT 2 optical port.
7. Place the On/Off switch in the **ON** position (press **I**) and observe the PORT 1/PORT 2 LED indicator.
8. The PORT 1/PORT 2 LED indicator will turn either red or green. If the LED turns red, either the PORT 1 optical transmitter or the PORT 2 receiver is faulty. If the LED turns green, both PORT 1 and PORT 2 optical ports are good.
9. Place the On/Off switch in the **OFF** position (press **O**).
10. Remove the dust caps from the optical fiber connectors.
11. Clean each connector (follow connector supplier's recommendations) and then insert each connector into the appropriate optical port.
12. When ready to put the unit back into service, place the On/Off switch in the **ON** position (press **I**).
13. Notify the NOC or alarm monitoring service that the system is going back online.

4.2.2 STM Loopback Test

1. Put on the IR filtering safety glasses.
2. Notify the NOC or alarm monitoring system operator that the system is going offline.
3. At the STM, place the On/Off switch in the **OFF** position (press **O**).
4. Disconnect the optical fiber connectors from the PORT 1 and PORT 2 optical ports and place a dust cap over each connector.
5. Plug a 15 dB in-line optical attenuator into the PORT 1 optical port.
6. Connect a patch cord between the optical attenuator and the PORT 2 optical port.
7. Place the On/Off switch in the **ON** position (press **I**) and observe the PORT 1/PORT2 LED indicator.
8. The PORT 1/PORT 2 LED indicator will turn either red or green. If the LED turns red, either the PORT 1 receiver is faulty or the PORT 2 transmitter is faulty. If the LED turns green, both PORT 1 and PORT 2 optical ports are good.
9. Place the On/Off switch in the **OFF** position (press **O**).
10. Remove the dust caps from the optical fiber connectors.
11. Clean each connector (follow connector supplier's recommendations) and then insert each connector into the appropriate optical port.
12. When ready to put the unit back into service, place the On/Off switch in the **ON** position (press **I**).
13. Notify the NOC or alarm monitoring service that the system is going back online.

5 MAINTENANCE PROCEDURES

This section specifies the system maintenance requirements and provides the procedures for the required maintenance tasks. Refer to these procedures as needed when specified in the Scheduled Maintenance table.

5.1 Scheduled Maintenance

Table 5-10 lists the items that require regular maintenance and the recommended maintenance interval. Refer to the section specified in the table for the required maintenance or test procedure.

Table 5-10. Scheduled Maintenance

INTERVAL	ITEM	REQUIREMENT
12 months	RU outdoor cabinet filter*	Remove and clean the RU outdoor cabinet filters. Refer to Section 5.2 for the required procedure.
60 months	HU Fans STM Fan LPA Fan	Remove and replace the cooling fans in the HU, STM, and LPA. Refer to specified section for the required procedures: HU see Section 5.3 , Section 5.4 , and LPA see Section 5.5 .
*Though it is not recommended that the RU be installed in a salt-air environment, if done so, clean the cabinet filter on a monthly basis instead of on a 12 month basis. In addition, the RU should be inspected for corrosion due to salt, particularly near the fans and around the connectors. The MTBF of the RU may be impacted if the RU is exposed to salt-air.		

5.2 Remote Unit Outdoor Cabinet Filter Cleaning Procedure

The RU outdoor cabinet filter cleans the RU intake air before it enters the cabinet. The filter should be cleaned approximately once per year and more often in extremely dirty environments. If the cabinet temperature gradually rises over a long period of time and there are no fan failures, it is possible that the filter is dirty and requires cleaning. Use the following procedure to clean the outdoor cabinet filter:

1. Open the RU outdoor cabinet door.
2. Loosen the two set screws that secure the filter to the bottom of the outdoor cabinet as shown in [Figure 5-1](#).
3. Pull the filter out and away from the bottom of the cabinet. Be careful not to damage the foam strip that provides the air seal.
4. Gently tap the filter against your hand to dislodge any dirt or dust. If necessary, use compressed air or a vacuum cleaner to remove dirt.
5. Carefully inspect the filter for holes or tears and replace it if damaged.
6. Orient the filter so the foam sealing strip is facing downward and then re-install the filter in the filter mounting slot (see [Figure 5-1](#)) at the bottom of the cabinet.
7. Re-tighten the two set screws to secure the filter to cabinet
8. Close the RU outdoor cabinet door.

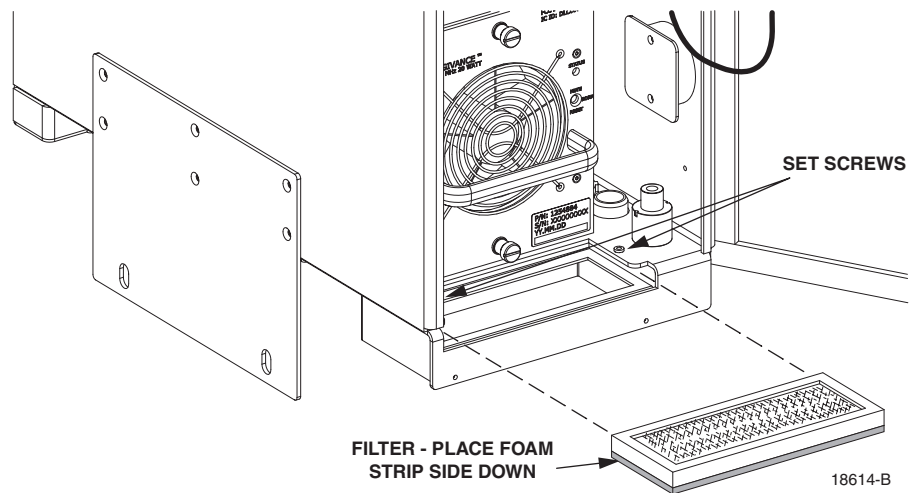

Figure 5-1. Cabinet Filter Removal and Replacement

5.3 Host Unit Fan Replacement Procedure

The HU is equipped with two cooling fans which are located on the right side of the HU enclosure. The cooling fans blow cool air into the enclosure. Heated air is exhausted through the vent openings on the left side of the enclosure. Replacement of the fans requires that the HU be turned off for a short period of time. Use the following procedure to remove and replace the HU cooling fans:

1. Before working on the HU or handling a fan, slip on an Electro-Static Discharge (ESD) wrist strap and connect the ground wire to an earth ground source. Wear the ESD wrist strap while completing each section of the fan installation procedure.



Warning: *Electronic components can be damaged by static electrical discharge. To prevent ESD damage, always wear an ESD wrist strap when working on the HU, STM, or LPA and when handling electronic components.*

2. Notify the NOC or alarm monitoring system operator that the system is going offline.
3. Place the **HU** On/Off switch in the **OFF** position (press **0**).
4. Remove the six flat-head screws (requires TORX screwdriver with T10 bit) that secure the fan/grill assembly to the right side of the HU enclosure as shown in [Figure 5-2](#). Save screws for reuse.
5. Carefully withdraw the fan/grill assembly from the enclosure until the wiring harness is exposed and the connectors are accessible.
6. Lift the small latch on each wiring harness connector and carefully unplug each connector from the circuit board connector.

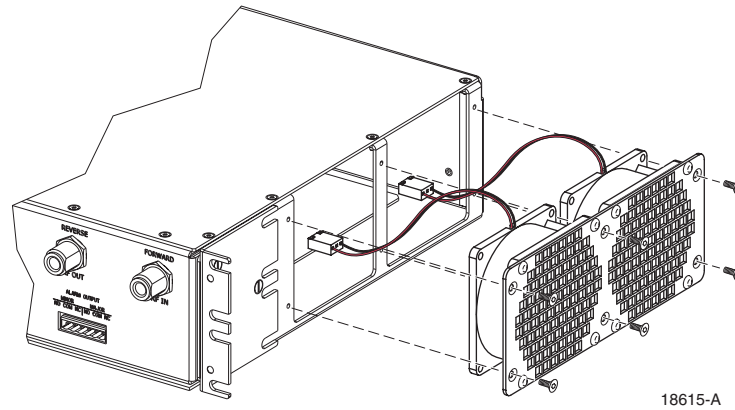

Figure 5-2. Host Unit Fan/Grill Assembly Removal

7. Remove the plastic rivets that secure each fan to the grill by pushing outward on the rivet center post until the rivet can be withdrawn from the grill as shown in [Figure 5-3](#).

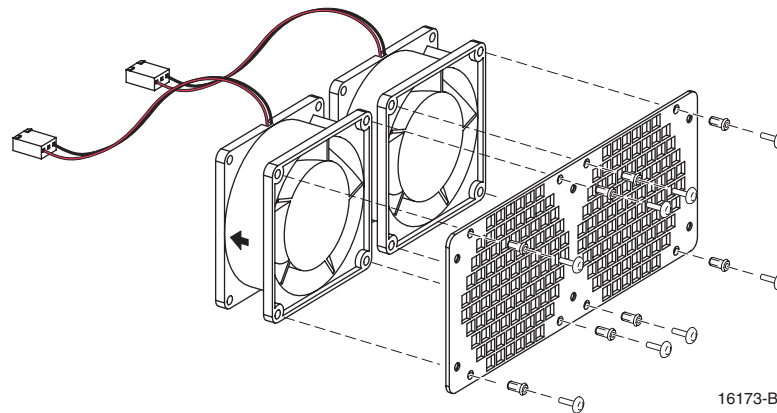

Figure 5-3. Removing Host Unit Fans From Grill

8. Remove both fans from the grill
9. Use the rivets removed in step 7 to secure the replacement fans to the grill. Orient each fan so the wiring harness is on the top and the arrow on the fan points **into** the enclosure.
10. Connect the two wiring harness connectors to the circuit board connectors.
11. Secure the fan/grill assembly to the side of the enclosure (see [Figure 5-2](#)) using the six flat-head screws removed in step 4.
12. Place the HU On/Off switch in the **ON** position (press **I**).
13. Verify that the fans run properly following power-up.
14. Notify the NOC or alarm monitoring system operator that the system is going back online.

5.4 Spectrum Transport Module Fan Replacement Procedure

The STM is equipped with a rear-mounted cooling fan. The rear fan exhausts heated air from the STM housing. Replacement of the fan requires that the STM be turned off for a short period of time and that the STM be removed from the outdoor cabinet or indoor mounting shelf. Use the following procedure to remove and replace the STM cooling fan.

1. Before working on the STM or handling a fan, slip on an Electro-Static Discharge (ESD) wrist strap and connect the ground wire to an earth ground source. Wear the ESD wrist strap while completing each section of the fan installation procedure.



Warning: *Electronic components can be damaged by static electrical discharge. To prevent ESD damage, always wear an ESD wrist strap when working on the HU, STM, or LPA and when handling electronic components.*

2. Notify the NOC or alarm monitoring system operator that the system is going offline.
3. Place the **STM On/Off** switch in the **OFF** position (press **0**).
4. Disconnect the various power, fiber optic, service, alarm wiring, and coaxial cable connectors from the STM front panel as specified in [Figure 5-4](#).

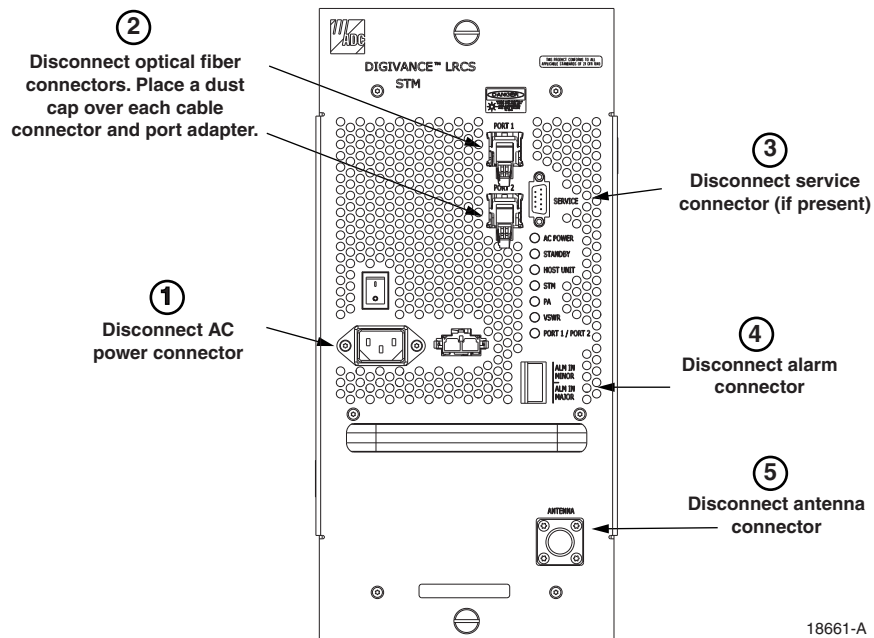

Figure 5-4. Spectrum Transport Module Cable Connections

5. Loosen the captive screws that secure the STM to the RU outdoor cabinet or indoor mounting shelf and carefully withdraw the STM from its mounting slot.
6. Remove the four pan-head screws (requires TORX screwdriver with T10 bit) that secure the fan/grill assembly to rear side of the STM housing as shown in [Figure 5-5](#). Save screws for reuse.

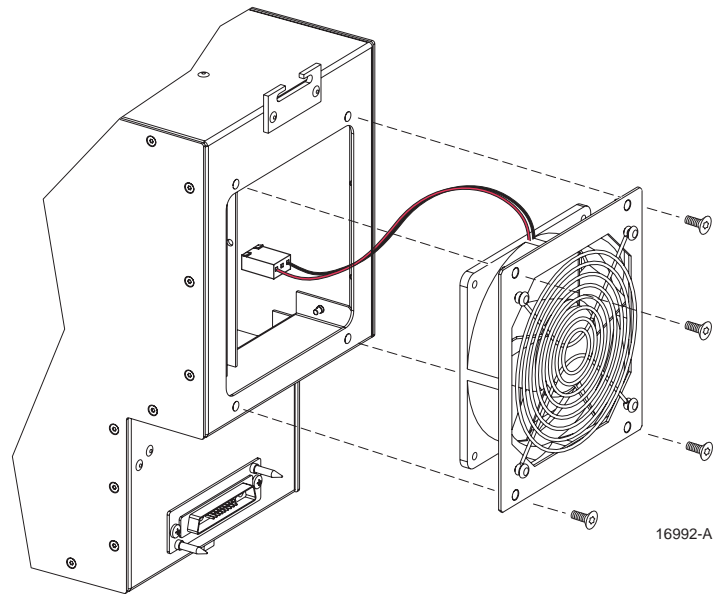

Figure 5-5. STM Fan/Grill Assembly Removal

7. Carefully withdraw the fan/grill assembly from the STM housing until the wiring harness is exposed and the connector is accessible.
8. Lift the small latch on the wiring harness connector and carefully unplug the connector from the circuit board connector.
9. Remove the plastic rivets that secure the fan to the mounting plate and grill by pushing outward on the rivet center post until the rivet can be withdrawn as shown in [Figure 5-6](#).
10. Separate fan from the mounting plate and grill

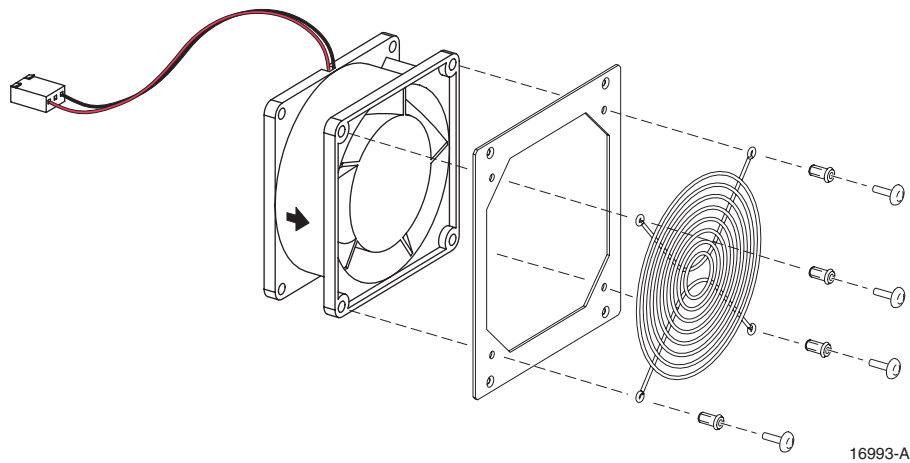

Figure 5-6. Removing STM Fan From Mounting Plate and Grill

11. Use the rivets removed in step 9 to secure the replacement fan to the mounting plate and grill. Orient the fan so the wiring harness is on the top and the arrow on the fan points **away** from the enclosure. Make certain the rubber grommets are left in place on the mounting plate.
12. Connect the wiring harness connector to the circuit board connector.
13. Secure the fan/grill assembly to the back of the housing (see [Figure 5-5](#)) using the four pan-head screws removed in step 6. Do not overtighten the screws. The screw threads can be easily stripped if too much torque is used to tighten the screws.
14. Re-install the STM in the outdoor cabinet or indoor mounting shelf and then re-connect all cables in the reverse order in which they were disconnected (see [Figure 5-4](#)).
15. Place the STM On/Off switch in the **ON** position (press **I**).
16. Verify that the fan runs properly following power-up.
17. Notify the NOC or alarm monitoring system operator that the system is going back online.

5.5 Linear Power Amplifier Fan Replacement Procedure

The LPA is equipped with a front-mounted cooling fan. The fan draws cool air into the LPA housing. Replacement of the fan requires that the STM be turned off for a short period of time and that the LPA be removed from the outdoor cabinet or indoor mounting shelf. Use the following procedure to remove and replace the LPA cooling fan.

1. Before working on the LPA or handling a fan, slip on an Electro-Static Discharge (ESD) wrist strap and connect the ground wire to an earth ground source. Wear the ESD wrist strap while completing each section of the fan installation procedure.



Warning: *Electronic components can be damaged by static electrical discharge. To prevent ESD damage, always wear an ESD wrist strap when working on the HU, STM, or LPA and when handling electronic components.*

2. Notify the NOC or alarm monitoring system operator that the system is going offline.
3. Place the **STM** On/Off switch in the **OFF** position (press **0**).
4. Loosen the captive screws that secure the LPA to the RU outdoor cabinet or indoor mounting shelf and carefully withdraw the LPA from its mounting slot.
5. Remove the four Phillips-head screws that secure the fan/front panel assembly to the front of the LPA housing as shown in [Figure 5-7](#). Save screws for reuse.
6. Carefully withdraw the fan/front panel assembly from the LPA housing until the wiring harness is exposed and the connector is accessible.
7. Carefully unplug the fan wiring harness connector from the LPA wiring harness connector.
8. Remove the screws, split-washers, and nuts that secure the fan and grill to the LPA front panel as shown in [Figure 5-8](#).
9. Separate the fan and grill from the front panel.

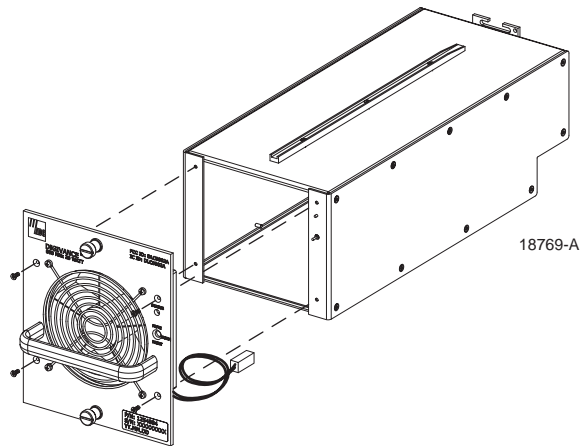

Figure 5-7. LPA Fan/Front Panel Assembly Removal

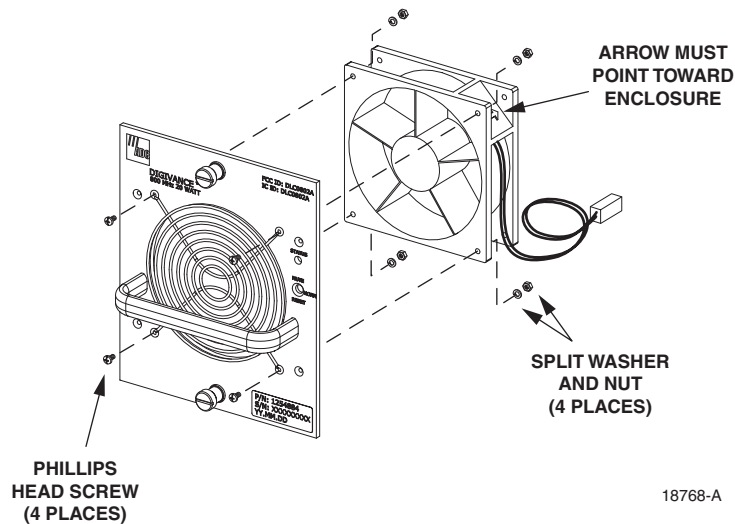

Figure 5-8. Removing LPA Fan From Front Panel

10. Use the screws, split-washers, and nuts removed in step 8 to secure the replacement fan and grill to the front panel. Orient the fan so the wiring harness is on the right side and the arrow on the fan points toward the rear of the housing.
11. Connect the fan wiring harness connector to the LPA wiring harness connector.
12. Secure the fan/front panel assembly to the front of the LPA housing using the four Phillips-head screws removed in step 5. Do not overtighten the screws. The screw threads can be easily stripped if too much torque is used to tighten the screws.
13. Re-install the LPA in the outdoor cabinet or indoor mounting shelf.

14. Place the STM On/Off switch in the **ON** position (press I)
15. Verify that the fan operates properly. The fan should exhaust air from the rear side of the LPA.
16. Notify the NOC or alarm monitoring system operator that the system is going back online.

Blank

SECTION 6: GENERAL INFORMATION

Content	Page
1 WARRANTY/SOFTWARE	6-1
2 SOFTWARE SERVICE AGREEMENT	6-1
3 REPAIR/EXCHANGE POLICY	6-1
4 REPAIR CHARGES	6-2
5 REPLACEMENT/SPARE PRODUCTS	6-2
6 RETURNED MATERIAL	6-2
7 CUSTOMER INFORMATION AND ASSISTANCE	6-3

1 WARRANTY/SOFTWARE

The Product and Software warranty policy and warranty period for all ADC Products is published in ADC's Warranty/Software Handbook. Contact the Technical Assistance Center at 1-800-366-3891, extension 73475 (in U.S.A. or Canada) or 952-917-3475 (outside U.S.A. and Canada) for warranty or software information or for a copy of the Warranty/Software Handbook.

2 SOFTWARE SERVICE AGREEMENT

ADC software service agreements for some ADC Products are available at a nominal fee. Contact the Technical Assistance Center at 1-800-366-3891, extension 73475 (in U.S.A. or Canada) or 952-917-3475 (outside U.S.A. and Canada) for software service agreement information.

3 REPAIR/EXCHANGE POLICY

All repairs of ADC Products must be done by ADC or an authorized representative. Any attempt to repair or modify ADC Products without written authorization from ADC voids the warranty.

If a malfunction cannot be resolved by the normal troubleshooting procedures, call the Technical Assistance Center at 1-800-366-3891, extension 73475 (in U.S.A. or Canada) or 952-917-3475 (outside U.S.A. and Canada). A telephone consultation can sometimes resolve a problem without the need to repair or replace the ADC Product.

If, during a telephone consultation, ADC determines the ADC Product needs repair, ADC will authorize the return of the affected Product for repair and provide a Return Material Authorization number and complete return shipping instructions. If time is critical, ADC can arrange to ship the replacement Product immediately. In all cases, the defective Product must be carefully packaged and returned to ADC.

4 REPAIR CHARGES

If the defect and the necessary repairs are covered by the warranty, and the applicable warranty period has not expired, the Buyer's only payment obligation is to pay the shipping cost to return the defective Product. ADC will repair or replace the Product at no charge and pay the return shipping charges.

Otherwise, ADC will charge a percentage of the current Customer Product price for the repair or NTF (No Trouble Found). If an advance replacement is requested, the full price of a new unit will be charged initially. Upon receipt of the defective Product, ADC will credit Buyer with 20 percent of full price charged for any Product to be Out-of-Warranty. Products must be returned within thirty (30) days to be eligible for any advance replacement credit. If repairs necessitate a visit by an ADC representative, ADC will charge the current price of a field visit plus round trip transportation charges from Minneapolis to the Buyer's site.

5 REPLACEMENT/SPARE PRODUCTS

Replacement parts, including, but not limited to, button caps and lenses, lamps, fuses, and patch cords, are available from ADC on a special order basis. Contact the Technical Assistance Center at 1-800-366-3891, extension 73475 (in U.S.A. or Canada) or 952-917-3475 (outside U.S.A. and Canada) for additional information.

Spare Products and accessories can be purchased from ADC. Contact Sales Administration at 1-800-366-3891, extension 73000 (in U.S.A. or Canada) or 1-952-938-8080 (outside U.S.A. and Canada) for a price quote and to place your order.

6 RETURNED MATERIAL

Contact the ADC Product Return Department at 1-800-366-3891, extension 73748 (in U.S.A. or Canada) or 952-917-3748 (outside U.S.A. and Canada) to obtain a Return Material Authorization number prior to returning an ADC Product.

All returned Products must have a Return Material Authorization (RMA) number clearly marked on the outside of the package. The Return Material Authorization number is valid for 90 days from authorization.

7 CUSTOMER INFORMATION AND ASSISTANCE

PHONE: _____

EUROPE

Sales Administration: +32-2-712-65 00

Technical Assistance: +32-2-712-65 42

EUROPEAN TOLL FREE NUMBERS

Germany: 0180 2232923

UK: 0800 960236

Spain: 900 983291

France: 0800 914032

U.S.A. OR CANADA

Sales: 1-800-366-3891 Extension 73000

Technical Assistance: 1-800-366-3891 Extension 73475

ASIA/PACIFIC

Sales Administration: +65-6294-9948

Technical Assistance: +65-6393-0739

ELSEWHERE

Sales Administration: +1-952-938-8080

Technical Assistance: +1-952-917-3475

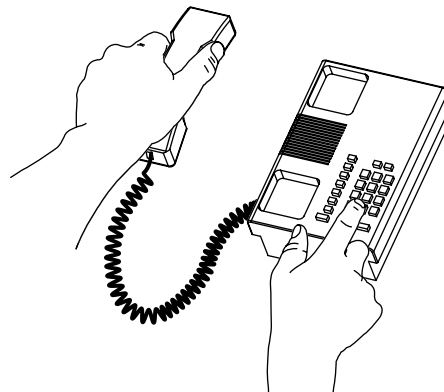

WRITE: _____

ADC TELECOMMUNICATIONS, INC
PO BOX 1101,
MINNEAPOLIS, MN 55440-1101, USA

ADC TELECOMMUNICATIONS (S'PORE) PTE. LTD.
100 BEACH ROAD, #18-01, SHAW TOWERS.
SINGAPORE 189702.

ADC EUROPEAN CUSTOMER SERVICE, INC
BELGICASTRAAT 2,
1930 ZAVENTEM, BELGIUM

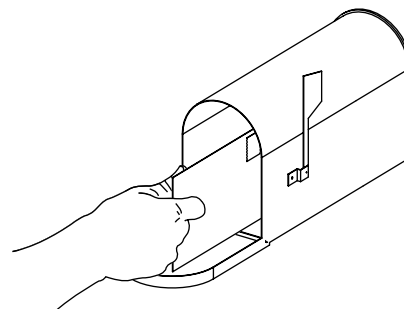

PRODUCT INFORMATION AND TECHNICAL ASSISTANCE: _____

connectivity_tac@adc.com

euro_tac@adc.com

asiapacific_tac@adc.com

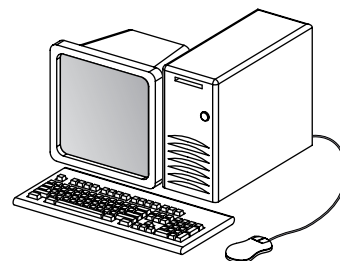

13944-J

Contents herein are current as of the date of publication. ADC reserves the right to change the contents without prior notice. In no event shall ADC be liable for any damages resulting from loss of data, loss of use, or loss of profits and ADC further disclaims any and all liability for indirect, incidental, special, consequential or other similar damages. This disclaimer of liability applies to all products, publications and services during and after the warranty period. This publication may be verified at any time by contacting ADC's Technical Assistance Center.



© 2003, ADC Telecommunications, Inc.
All Rights Reserved
Printed in U.S.A .



www.adc.com