

The NOC/NEM interface is a command line interface that is presented at an NOC terminal. The NOC/NEM interface is used for **remote** control and monitoring operations. The NOC/NEM interface consists of ASCII text strings that are input as standard SET or GET commands which are followed by the action or information required. A text string response is received from the specified system or systems to confirm the requested action or to report the requested information. Examples of several typical NOC-NEM interface commands and the responses received are shown in Figure 2-19. The NOC/NEM interface requires only a VT100 terminal/emulator or a PC-type computer that is loaded with a communication software such as Procomm Plus. While primarily intended for use at the NOC, the NOC/NEM interface commands may also be input from the EMS computer.

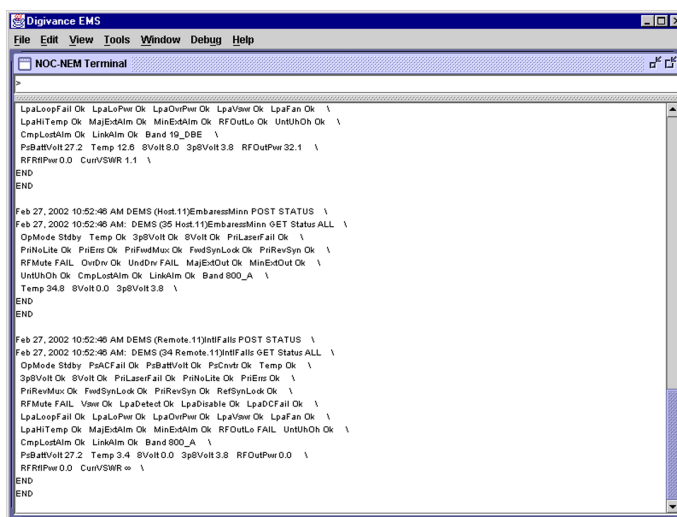

Figure 2-19. NOC/NEM Interface Typical Commands

## 11 SPECIFICATIONS

Refer to Table 2-6 for the Digivance 1900 MHz 20 Watt System nominal specifications. All specifications apply after a five minute warm-up period.

Table 2-6. 1900 MHz 20 Watt System Nominal Specifications

PARAMETER	SPECIFICATION	REMARKS
<b>Optical - Host and Remote Unit</b>		
Fiber type	9/125, single-mode	
Number of fibers required		The wavelength division multiplexer (WDM) is an accessory.
Direct	2	
With WDM	1	
Forward path wavelength	1550 nm	
Reverse path wavelength	1310 nm	

**Table 2-6. 1900 MHz 20 Watt System Nominal Specifications, continued**

PARAMETER	SPECIFICATION	REMARKS
Optical transmit power output Host Unit Remote Unit	0 dBm +2 dBm	
Optical budget	25 dB	For optical BER of 10 <sup>-6</sup>
Optical receive input	-15 dBm maximum	
Optical connectors	Industry standard SC	Host, remote, and WDM
<b>Optical - Host and Remote WDM</b>		
Passband	1310 nm ± 20 nm 1550 nm ± 20 nm	
Forward path insertion loss Host WDM Remote WDM	0.7 dB 0.3 dB	Does not include connector loss
Reverse path insertion loss Host WDM Remote WDM	0.3 dB 0.7 dB	Does not include connector loss
Isolation	> 30 dB minimum	
Return loss (Reflectance)	< -50 dB	All input ports
<b>RF Forward Path - 1900 MHz</b>		
System bandwidth	20 MHz AD band, 25 MHz DBE, BEF, and EFC bands	
Frequency range AD DBE BEF EFC	1930 to 1950 MHz 1945 to 1970 MHz 1950 to 1975 MHz 1965 to 1990 MHz	
Out-of-band emissions Primary  Secondary (see Note 1)	-13 dBm per 1 MHz bandwidth from 10 kHz to 20 GHz -98 dBm per 100 kHz from 824 to 849 MHz and from 1850 to 1910 MHz	
Gain of forward path (Host input to Remote antenna port)	80.5 dB at band center, room temperature, and 0 dB attenua- tion setting	Includes power amplifier.
Gain flatness Band flatness Channel flatness	± 1.5 dB across freq. range ±1 dB variation across any 1.25 MHz channel	
Gain variation	± 3 dB over temp and unit-to- unit	
Out-of-band rejection	-40 dB at ≥ ±17.5 MHz from 881.5 MHz	
Propagation delay	6 μs	Excludes fiber delay

**Table 2-6. 1900 MHz 20 Watt System Nominal Specifications, continued**

PARAMETER	SPECIFICATION	REMARKS
Configurable propagation delay Range Step size	Up to 63 $\mu$ s 0.1 $\mu$ s	Plus standard propagation delay
Spurious In-band self generated Free dynamic range	-13 dBm at remote output 60 dB at 30 kHz bandwidth	
Transmit peak-to-average	10 dB	
Two-tone Intermodulation	-55 dBc at remote output	Two CW tones at 5 Watts each
CDMA Intermodulation 885 kHz to 1.25 MHz 1.25 to 1.98 MHz 1.98 to 2.25 MHz	-45 dBc per 30 kHz -8 dBm per 30 kHz -55 dBc per 30 kHz	Absolute level
Nominal composite RF input signal level	-40 dBm at 0 dB attenuation -9 dBm at max. attenuation	An input signal level of -40 dBm provides maximum output power
Configurable input level Range Step size	31 dB $1 \pm 0.5$ dB $\pm 10\%$ of attenuation monotonic	
Composite RF Output power	40.5 dBm (11 Watts) at remote antenna port with -40 dBm input	20 Watts at power amplifier output
Configurable RF Output Range Step size	31 dB at remote unit $1 \pm 0.5$ dB $\pm 10\%$ of attenuation monotonic	
Transmit path insertion loss	2.5 dB	
<b>RF Reverse Path - 1900 MHz</b>		
System bandwidth A band B band	20 MHz AD band, 25 MHz DBE, BEF, and EFC bands	
Frequency range AD DBE BEF EFC	1850 to 1870 MHz 1865 to 1890 MHz 1870 to 1895 MHz 1885 to 1910 MHz	
In band spurs (caused by an individual out-of-band signal)	-75 dBc (1 MHz to 20 GHz and > 10 MHz out-of-band) -120 dBc (1930 to 1990 MHz) -120 dBc (869 to 894 MHz)	Required for dual band
Propagation delay	6 $\mu$ s	Excludes fiber delay
Configurable propagation delay Range Step size	Up to 63 $\mu$ s 0.1 $\mu$ s	Plus standard propagation delay

**Table 2-6. 1900 MHz 20 Watt System Nominal Specifications, continued**

PARAMETER	SPECIFICATION	REMARKS
Gain flatness Band flatness Channel flatness	±1.5 dB across frequency range ±1 dB variation across any 1.25 MHz channel	
Gain of reverse path Overall gain Gain variation	30 dB at band center at room temperature 3 dB over temperature	ALC not invoked ALC not invoked
Out-of-band rejection	-40 dB at ≥ ±17.5 MHz from 836.6 MHz	ALC not invoked
Spurious (in-band self generated)	-110 dBm referred to input	ALC not invoked
Intermodulation	-62 dBc two tones at -50 dBm	
System noise figure	8 dB at mid-band	ALC not invoked
Configurable RF output Range Step size	31 dB 1 ±0.5 dB ±10% of attenuation monotonic	
Blocking dynamic range	70 dB	
Level limiting ALC threshold	-40 dBm dB instantaneous	
Level limiting ALC range	30 dB	
<b>RF Forward and Reverse Path Modulation Accuracy</b>		
Service/Mod Type/Parameter TDMA/n/4-DQSK/rms EVM GSM/GMSK/rms phase error EDGE/8PSK/rms EVM EIA-97D/CDMA/rho factor	7% 4° 7% .97%	
<b>Physical/Environmental/ Electrical - Host Unit</b>		
Dimensions (H×W×D)	3.5 × 17.2 × 15.3 inches (89 × 437 × 389 mm)	Dimension for width does not include the mounting brackets which can be installed for either 19- or 23-inch racks.
Mounting	19- or 23-inch rack	EIA or WECO
Weight	18 lbs. (8.2 kg)	
Weather resistance	Indoor installation only	
Operating temperature	0° to 50° C (32° to 122° F)	
Storage temperature	-40° to 70° C (-40° to 158°F)	
Humidity	10% to 90%	No condensation
External alarm connector	Screw-type terminals	NO and NC relay contacts

**Table 2-6. 1900 MHz 20 Watt System Nominal Specifications, continued**

PARAMETER	SPECIFICATION	REMARKS
DC power connector	Screw-type terminal strip	
RF coaxial cable connectors	N-type (female)	
Service connector	DB-9 (female)	RS-232 DTE interface
CAN connectors	RJ-45 jack	
Power input	$\pm 24$ or $\pm 48$ VDC	$\pm 21$ to $\pm 60$ VDC
Power consumption	55 watts	
Current rating	1 Amp at $-48$ VDC	
Reliability at 25°C	MTBF 80,000 hours	Excluding fans
<b>Physical/Environmental/ Electrical - Remote Unit Outdoor Cabinet</b>		
Cabinet dimensions (H×W×D)	25.6 × 10.13 × 20.75 inches (674 × 257 × 527 mm)	
Mounting	Wall, pole, or pedestal	Pedestal mounting requires pedestal mount kit. (accessory)
Weight	80 lbs (36.3 kg)	Includes modules
Weather resistance	NEMA-3R, removable dust filter	
Operating temperature	$-30^{\circ}$ to $50^{\circ}$ C ( $-22^{\circ}$ to $122^{\circ}$ F)	
Storage temperature	$-40^{\circ}$ to $70^{\circ}$ C ( $-40^{\circ}$ to $158^{\circ}$ F)	
Humidity	10% to 90%	No condensation
External alarm connector	Screw-type terminals	External alarm inputs
AC power connection	3/4- or 1/2-inch conduit	Per local code or practice.
Antenna cable connector	N-type female	
Fiber optic cable size	0.375 to 0.875 inch (10 to 22 mm) diameter cable	9/125, single-mode
Lightning protection	20 kA IEC 1000-4-5 8/20 $\mu$ s waveform	
Service connector	DB-9 female (on STM)	RS-232 DTE interface
Power input	120 or 240 VAC, 50 or 60 Hz	
Power consumption	360 Watts	
Current rating	5 Amps maximum at 120 VAC	
Reliability at 25°C	MTBF 50,000 hours	Excluding fans and air filter
<b>Physical/Environmental/ Electrical - Remote Unit Indoor Mounting Shelf</b>		
Mounting Shelf dimensions (H×W×D)	14.15 × 17.39 × 15.6 inches (359 × 442 × 396 mm)	

**Table 2-6. 1900 MHz 20 Watt System Nominal Specifications, continued**

PARAMETER	SPECIFICATION	REMARKS
Mounting	19-inch equipment rack	WECO or EIA
Weight	50 lbs. (22.7 kg)	Includes modules
Operating temperature	-30° to 50° C (-22° to 122° F)	
Storage temperature	-40° to 70° C (-40° to 158°F)	
Humidity	10% to 90%	No condensation
External alarm connector	Screw-type terminals (on STM)	External alarm inputs
AC power connection	AC power cord with standard 3-prong 120 VAC plug.	
Antenna cable connector	N-type female (on STM)	
Fiber optic cable connector	SC-type (on STM)	
Service connector	DB-9 female (on STM)	RS-232 DTE interface
Power input	120 or 240 VAC, 50 or 60 Hz	Operation on 240 VAC requires power cord with 240 VAC plug.
Power consumption	360 Watts	
Current rating	3 Amps maximum at 120 VAC	
Reliability at 25°C	MTBF 50,000 hours	Excluding fans and air filters

Note 1: Required for co-located sites such as dual band. Otherwise, the emissions from one unit can limit the sensitivity of the other.

## SECTION 3: HOST UNIT INSTALLATION

Content	Page
<b>1 BEFORE STARTING INSTALLATION</b> .....	<b>3-1</b>
<b>1.1 Tools and Materials</b> .....	<b>3-1</b>
<b>1.2 Unpacking and Inspection</b> .....	<b>3-2</b>
<b>2 FIBER OPTIC CABLE ROUTING AND INSTALLATION GUIDELINES</b> .....	<b>3-2</b>
<b>3 WDM MOUNTING PROCEDURE (OPTIONAL ACCESSORY)</b> .....	<b>3-4</b>
<b>4 HU MOUNTING PROCEDURE</b> .....	<b>3-6</b>
<b>5 CHASSIS GROUND CONNECTION</b> .....	<b>3-8</b>
<b>6 COAXIAL CABLE CONNECTIONS</b> .....	<b>3-8</b>
<b>7 OPTICAL CONNECTIONS</b> .....	<b>3-10</b>
<b>7.1 Optical Connections Without WDM or CWDM system</b> .....	<b>3-10</b>
<b>7.2 Optical Connections With WDM System</b> .....	<b>3-11</b>
<b>8 CONTROLLER AREA NETWORK CONNECTIONS</b> .....	<b>3-13</b>
<b>9 EMS COMPUTER CONNECTION</b> .....	<b>3-14</b>
<b>10 EXTERNAL ALARM SYSTEM CONNECTIONS</b> .....	<b>3-15</b>
<b>11 DC POWER CONNECTIONS</b> .....	<b>3-16</b>

### 1 BEFORE STARTING INSTALLATION

This section provides the installation procedures for the HU, the WDM host module mounting shelf (accessory), and the WDM host module (accessory). Installation of the RU outdoor cabinet or RU indoor mounting shelf and the RU electronic modules may proceed separately from installation of the HU. The mounting procedures for the outdoor remote cabinet are provided in the 20 Watt Outdoor Remote Cabinet Mounting Instructions (ADCP-75-147) which are shipped with the cabinet. The installation procedures for the STM and LPA electronic modules are provided in the 20 Watt Indoor Remote Unit Installation Instructions (ADCP-75-149) and the 20 Watt Outdoor Remote Unit Installation Instructions (ADCP-75-148) which are shipped respectively with the outdoor cabinet and indoor mounting shelf. When all units of the Digivance system have been installed, refer to Section 4 of this manual for the system turn-up and test procedures.

Before beginning the installation, review the system design plan with the system engineer. Make sure each equipment installation site is identified and located and all cable runs are mapped out.

#### 1.1 Tools and Materials

The following tools are required to complete the procedures in this section:

- Box cutter
- Pencil or scribe
- Medium size flat-bladed screwdriver

- Phillips screwdriver (#2)
- TORX screwdriver (T20 bit)
- Pliers
- Wire cutters
- Wire stripper
- Tool kit for attaching N-type male connectors to coaxial cable
- Multimeter
- Optical power meter

The following materials are required to complete the procedures in this section:

- #18 AWG (1.0 mm) insulated stranded copper wire (for chassis grounding wire)
- #18 AWG (1.0 mm) red and black insulated copper wire (for DC power wires)
- Category 3 or 5 cable (for external alarm system wires)
- #6 ring terminal (1) for #18 wire (for chassis ground wire connection)
- #6 fork terminals (2) for #18 wire (for DC power wiring connection)
- Single-mode patch cord(s) with SC connectors (1, 2 or 3 depending on the application)
- High performance, flexible, low-loss 50-ohm coaxial cable
- N-type male connectors
- Wire ties

## 1.2 Unpacking and Inspection

This section provides instructions for opening the shipping boxes, verifying that all parts have been received, and verifying that no shipping damage has occurred. Use the following procedure to unpack and inspect the HU and any accessories:

1. Open the shipping cartons and carefully unpack each component from the protective packing material.
2. Check each component for broken or missing parts. If there are damages, contact ADC (see section 6 at the end of this manual) for an RMA (Return Material Authorization) and to reorder if replacement is required.

## 2 FIBER OPTIC CABLE ROUTING AND INSTALLATION GUIDELINES

The outside plant (OSP) fiber optic cables should be routed between the HU and RU and terminated before the equipment is installed. A diagram of a typical fiber optic cable routing is shown in [Figure 3-1](#). At the HU, the OSP cable should be terminated at a fiber distribution panel and spliced to pigtails. Patch cords may then be used to link the HU optical ports to the OSP cable terminations. Whenever possible, a guideway such as the FiberGuide system should be provided to protect the fiber optic patch cords from damage and to prevent excessive bending. The procedures for connecting the OSP cable optical fibers to the HU is provided in [Section 7](#).



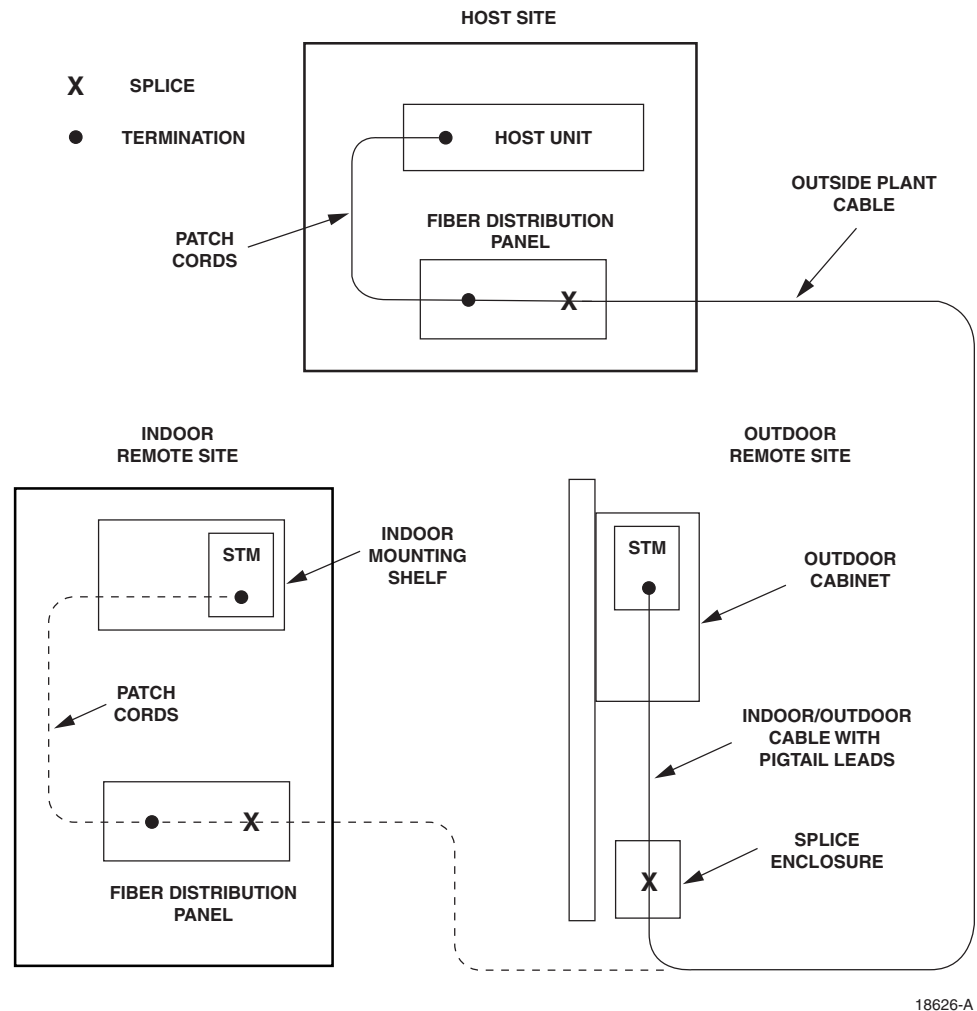

**Figure 3-1. Typical Fiber Optic Cable Routing**

When routed to the RU **outdoor cabinet**, the OSP fiber optic cable should be spliced to a connectorized outdoor-rated cable (consisting of individual jacketed pigtails) which is then routed into the outdoor cabinet. The individual pigtails can then be connected directly to the STM optical ports. A connector is provided on the bottom of the RU outdoor cabinet to seal the cable entry point and provide strain relief. The procedure for routing the fiber cable into an outdoor cabinet and for connecting the pigtail leads to the STM is provided in the Digivance 20 Watt Outdoor Remote Unit Installation Instructions (ADCP-75-148).

When routed to RU **indoor mounting shelf**, the OSP cable should be terminated at a fiber distribution panel and spliced to pigtails. Jumper patch cords may then be used to link the STM optical ports to the OSP cable terminations. Whenever possible, a guideway such as the FiberGuide system should be provided to protect the fiber optic patch cords from damage and to prevent excessive bending. The procedure for connecting the OSP optical fibers to an STM mounted in the indoor mounting shelf is provided in the Digivance 20 Watt System Indoor Remote Unit Mounting Shelf Installation Instructions (ADCP-75-149).

### 3 WDM MOUNTING PROCEDURE (OPTIONAL ACCESSORY)

A bi-directional wavelength division multiplexer (WDM) system is available as an accessory item for the Digivance system. If the application does not require the use of a WDM system, skip this section and proceed to [Section 4](#).

At the HU, the WDM system consists of a WDM host module and a WDM host module mounting shelf. Each host module can support two HU's and each host module mounting shelf can hold two host modules. A fully loaded host module mounting shelf can therefore support four HU's.

When multiple HU's require connection to a WDM system, the host module mounting shelf and the HU's should be mounted in the equipment rack as shown in [Figure 3-2](#). This configuration allows the pigtail leads from the two host modules to be connected directly to the optical ports on any one of the four HU's.

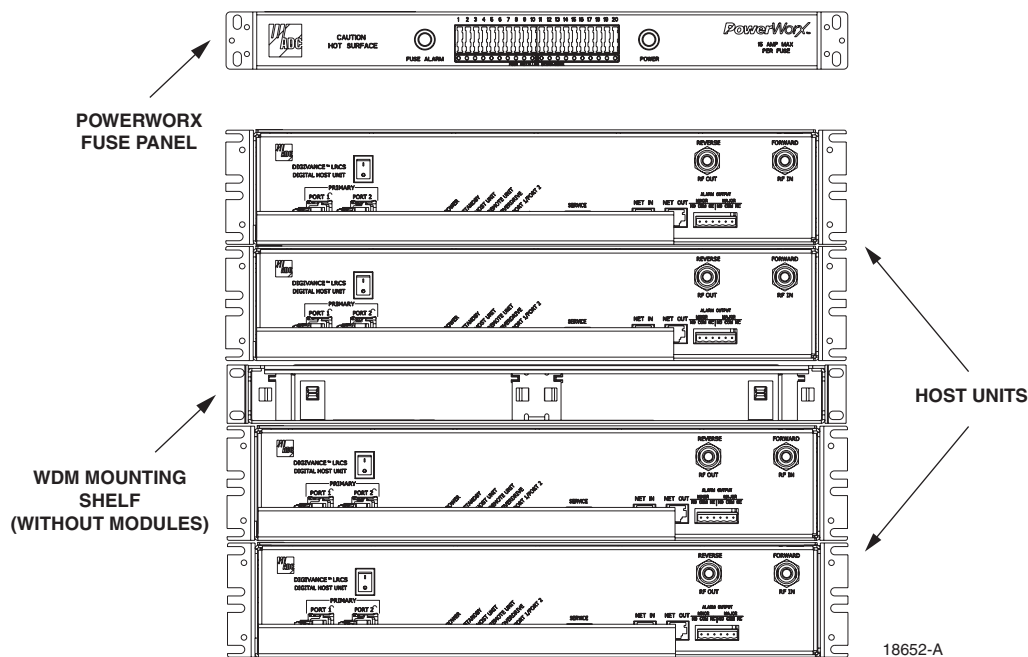
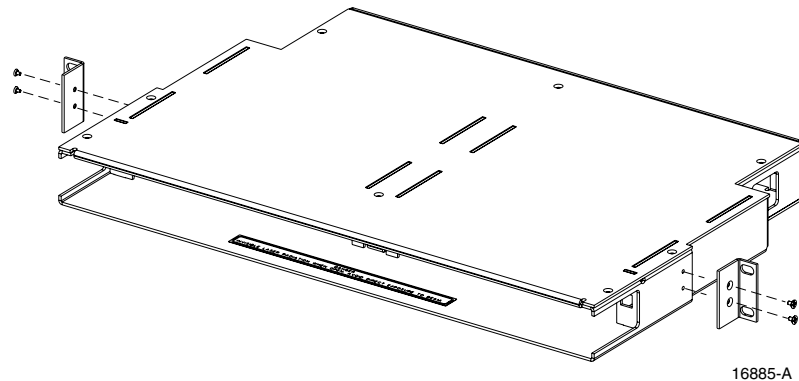

**Figure 3-2. Typical WDM and HU Configuration**

The WDM host module mounting shelf may be mounted in either a 19-inch or 23-inch EIA or WECO equipment rack. Four #12-24 screws are provided for securing the mounting shelf to the rack. Use the following procedure to install the host module mounting shelf in the equipment rack and to mount the host modules in the host module mounting shelf:

1. The host module mounting shelf is shipped with the mounting brackets installed for 19-inch EIA rack installations. If installing the mounting shelf in a 19-inch EIA rack, proceed to step 5. If installing the mounting shelf in a 19-inch WECO rack, a 23-inch EIA rack, or a 23-inch WECO rack, proceed to step 2.

2. Remove both mounting brackets from the mounting shelf (requires Phillips screwdriver) and save screws for reuse.
3. Locate the extra mounting brackets that are provided with the mounting shelf and select the brackets that correspond to the rack type. Each mounting shelf includes extra brackets for installing the mounting shelf in the following rack types:
  - 19-inch EIA
  - 19-inch WEKO
  - 23-inch EIA
  - 23-inch WEKO
4. Install the replacement mounting brackets as shown in [Figure 3-3](#). Use the screws removed in step 2 to attach the new brackets to the mounting shelf.



**Figure 3-3. Installing the Replacement Mounting Brackets**

5. Position the mounting shelf in the designated mounting space in the rack (per system design plan) and then secure the mounting brackets to the rack using the four #12-24 machine screws provided as shown in [Figure 3-4](#).
6. Install each host module in the mounting shelf (see [Figure 3-4](#)). A rail on the side of the module fits into a guide within the mounting.
7. Secure each host module to the mounting shelf by twisting the handle on each quarter-turn fastener 90°.
8. Carefully store the pigtail leads from each host module. The routing and connection procedures for the pigtails are provided in [Section 7](#).

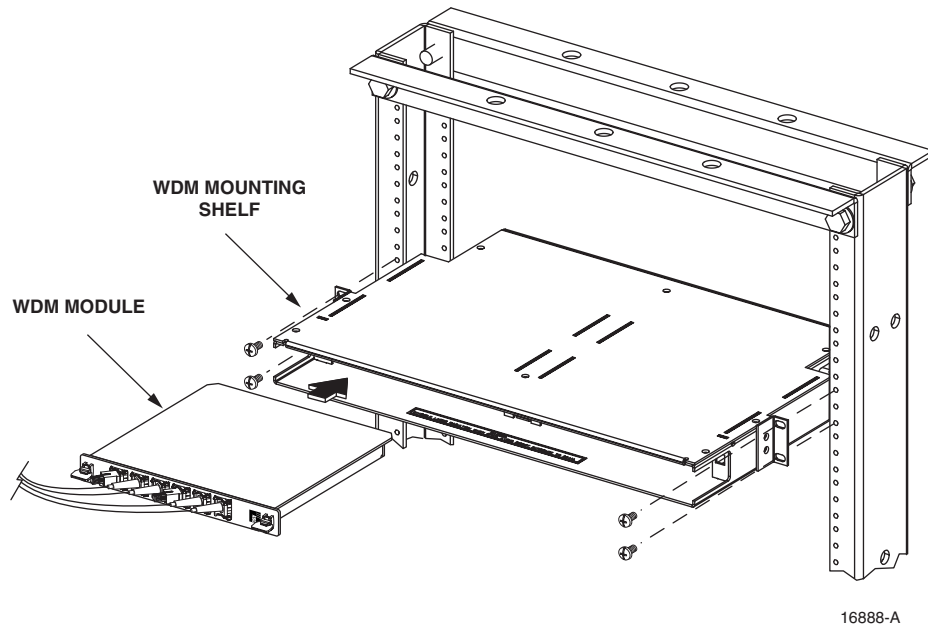

Figure 3-4. WDM Host Module Mounting Shelf and WDM Host Module Installation

## 4 HU MOUNTING PROCEDURE

The HU may be mounted in either a 19-inch or 23-inch EIA or WECO equipment rack. Both US standard and metric machine screws are included for rack mounting the HU. When loading the HU in a rack, make sure the mechanical loading of the rack is even to avoid a hazardous condition such as a severely unbalanced rack. The rack should safety support the combined weight of all the equipment it holds. In addition, maximum recommended ambient temperature for the HU is 50° C (122° F). Allow sufficient air circulation or space between units when the HU is installed in a multi-rack assembly because the operating ambient temperature of the rack environment might be greater than room ambient.



**Warning:** *Wet conditions increase the potential for receiving an electrical shock when installing or using electrically powered equipment. To prevent electrical shock, never install or use electrical equipment in a wet location or during a lightning storm.*



**Note:** To insure that all optical connectors remain dust-free during installation, leave all dust caps and dust protectors in place until directed to remove them for connection.

Use the following procedure to install the HU in the equipment rack:

1. The HU is shipped with the mounting brackets installed for 19-inch rack installations. If mounting the HU in a 19-inch rack, proceed to step 4. If mounting the HU in a 23-inch rack, proceed to step 2.
2. Remove both mounting brackets from the HU (requires TORX screwdriver with T20 bit) and save screws for reuse.

3. Reinstall both mounting brackets so the long side of the bracket is flush with the HU front panel as shown in [Figure 3-5](#). Use the screws removed in step 2 to re-attach the brackets to the HU chassis.

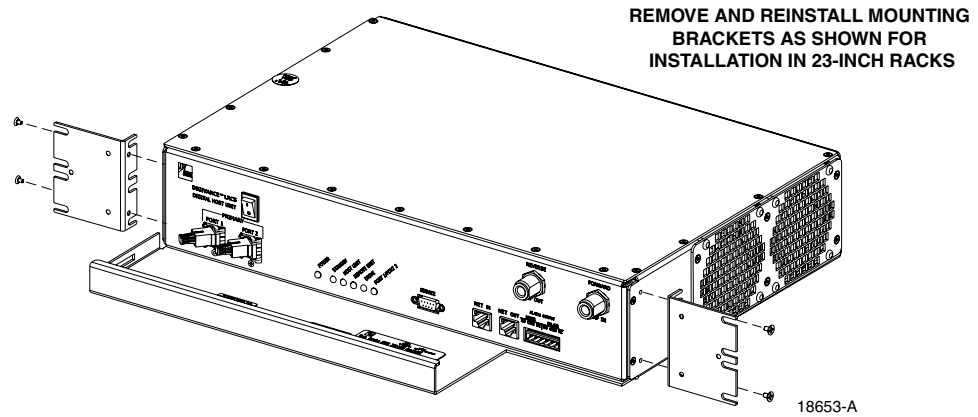

**Figure 3-5. Installing the Mounting Brackets for 23-Inch Rack Installations**

4. Position the HU in the designated mounting space in the rack (per system design plan) and then secure the mounting brackets to the rack using the four machine screws provided (use #12-24 or M6 x 10 screws, whichever is appropriate) as shown in [Figure 3-6](#).

► **Note:** Provide a minimum of 3 inches (76 mm) of clearance space on both the left and right sides of the HU for air intake and exhaust.

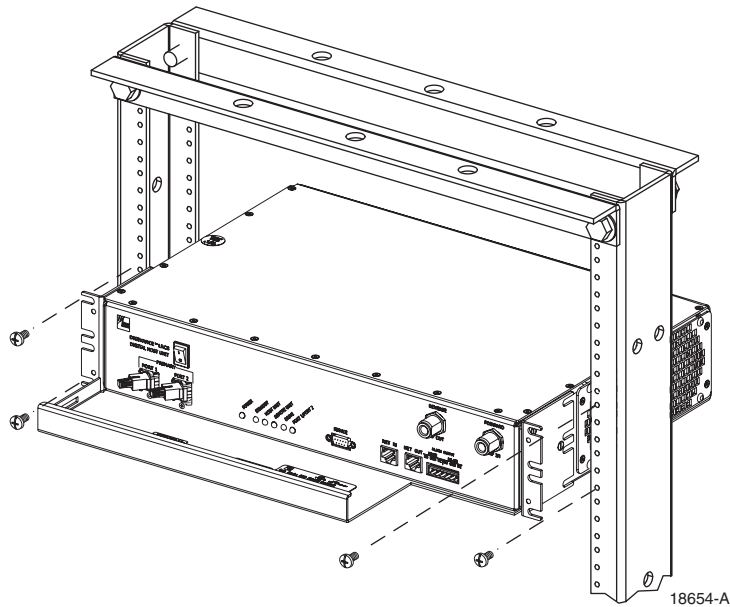

**Figure 3-6. HU Rack Mount Installation**