

3.6 Antenna Cable Connection

An N-type female connector is provided on the exterior bottom side of the RU cabinet for connecting the antenna coaxial cable. The exterior N-type connector is on the surge side of a lightning protector that is mounted within the enclosure. On the inside of the enclosure, the protected side of the lightning protector is also equipped with an N-type female connector. A coaxial jumper cable (included with the enclosure) is used for connecting the protected side of the lightning protector to the ANTENNA port on the STM.

3.7 AC Power Wiring and Grounding

The RU outdoor cabinet is equipped with a stub cable for the AC power connections. The AC power cable provides three wire leads (Load, Neutral, and Ground) that must be connected to a 120 or 240 VAC power source. The AC power cable exits the cabinet through a 3/4-inch NPT threaded hole located on the bottom of the cabinet. The threaded hole accepts a standard 3/4-inch AC conduit fitting. A 3/4-inch to 1/2-inch reducer is also included if 1/2-inch conduit is preferred over 3/4-inch conduit.

From the exit point in the bottom of the cabinet, the AC power cable must be routed through conduit to an external AC junction box (not provided) where it can be connected to the AC power wiring. The junction box should be located within two feet of the cabinet and should be equipped with a 120 VAC outlet for powering test equipment and/or power tools. If AC power spikes are likely to occur, the junction box should also include a surge protector to protect the equipment from damage.

Three wire nuts are included with the cabinet for completing the AC power wiring connections. The junction box wiring should be connected to the AC power source through a 20 Amp breaker box (not provided). All AC power wiring should be run within conduit. A grounding lug is provided on the underside of the enclosure for connecting a separate grounding wire directly to the cabinet.

3.8 Ventilation

Vent openings are provided in the door, on the bottom, and on the rear side of the RU cabinet to permit air exchange for cooling. Air enters the cabinet through the openings in the door and bottom. Filters remove dirt particles so that only clean air enters the enclosure. Both the STM and LPA have cooling fans. The STM has a rear mounted fan that pulls air through the module and exhausts it toward the rear of the enclosure. The LPA has a fan on the front that draws air into the module and exhausts it toward the rear of the enclosure. The heated air exits through an opening in the rear side of the enclosure.

3.9 User Interface

The RU cabinet user interface consists of the various connectors, fittings, mounting slots, and switches that are provided on both the interior and exterior of the enclosure. The user interface points are indicated in [Figure 2-4](#) and described in [Table 2-2](#).

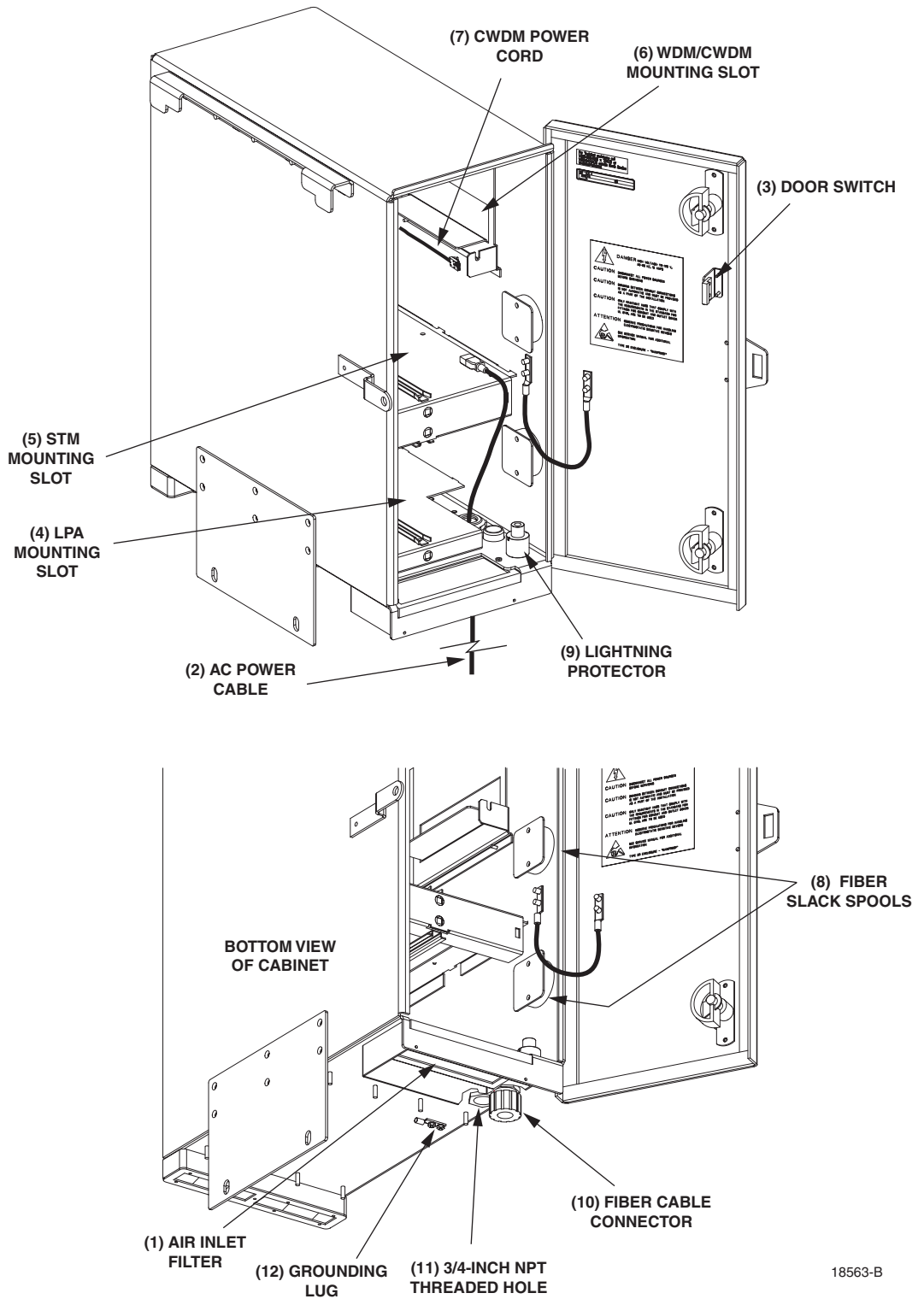

18563-B

Figure 2-4. Remote Unit Outdoor Cabinet User Interface

Table 2-2. Remote Unit Cabinet User Interface

REF NO	DEVICE	FUNCTIONAL DESCRIPTION
1	Air inlet filter	Reusable filter that prevents the entry of dirt particles when outside air is pulled into the cabinet for cooling.
2	AC power cord	Provides AC power to the STM.
3	Door switch	Indicates to the fault detection and alarm reporting system if the cabinet door is open (major alarm) or closed.
4	LPA mounting slot	Provides a mounting point for the LPA module.
5	STM mounting slot	Provides a mounting point for the STM module.
6	WDM/CWDM mounting slot	Provides a mounting point for either the WDM or CWDM module.
7	CWDM power cord	Provides DC power to the CWDM module.
8	Fiber slack spools	Provide a storage place for excess fiber pigtail and patch cord slack.
9	Lightning protector	Provides lightning surge protection for the antenna connection.
10	Fiber cable connector	Provides both an entry point and strain relief for the fiber optic cable.
11	3/4-inch NPT threaded hole	Provides a connection point for a 3/4-inch AC conduit fitting.
12	Grounding lug	Provides a connection point for an external grounding cable.

4 REMOTE UNIT INDOOR MOUNTING SHELF

The RU indoor mounting shelf, shown in [Figure 2-5](#), is a rack-mountable framework that provides the following basic functions:

- Supports the various electronic modules (STM and LPA) and accessories (WDM or CWDM) for mounting within a standard 19-inch, WECCO or EIA, equipment rack.
- Provides the electrical interface connections for the STM and LPA modules.
- Provides an AC power cord for powering the STM module
- Provides DC power connections for the CWDM module.

4.1 Primary Components

The RU indoor mounting shelf is a rack-mountable frame assembly that provides mounting slots for the STM, LPA, WDM (accessory), and CWDM (accessory) modules plus connectors and a wiring harness for interfacing the STM and LPA modules. The indoor mounting shelf is designed for mounting in a standard 19-inch, EIA or WECCO, equipment rack. The frame assembly is constructed of aluminum and is painted putty white for corrosion protection.

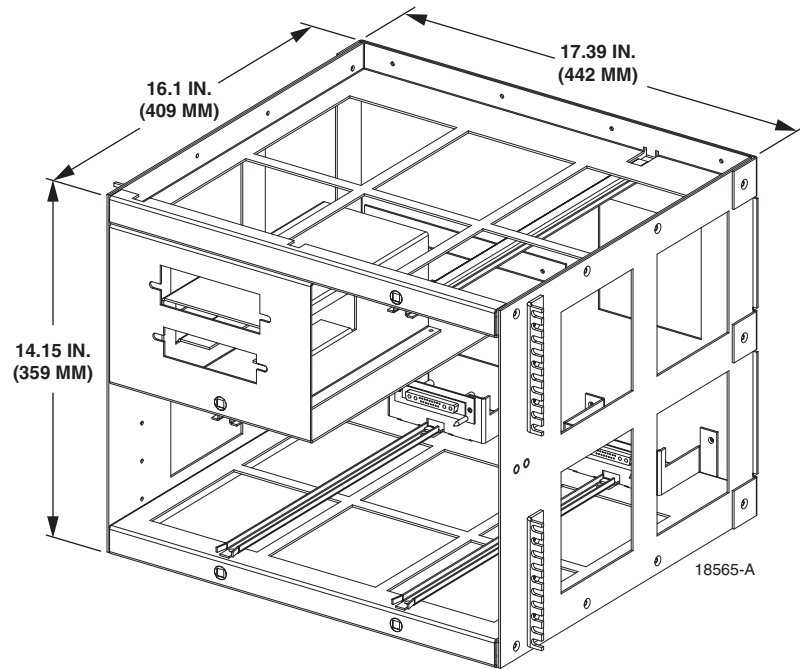

Figure 2-5. Remote Unit Indoor Mounting Shelf

4.2 STM and LPA Module Installation

Two mounting slots are provided within the indoor mounting shelf for installing the STM and LPA modules. The mounting slots include tracks that guide each module into the installed position. Separate mounting slots are provided for STM and LPA modules. Two D-sub connectors (one male, one female) are located at the rear of each mounting slot. Each mounting slot connector mates with a corresponding D-sub connector located on the rear side of each module. A wiring harness links the mounting slot connectors together. The connectors and the attached wiring harness provide the electrical interface between the STM and LPA modules. The modules are held in the installed position with captive screws.

4.3 WDM and CWDM Installation

Mounting slots are provided in the indoor mounting shelf for installing a WDM or CWDM module (accessory items). Each module is equipped with push-pull type fasteners for securing the module to the mounting slot. A power cable is included with the mounting shelf for supplying DC power when a CWDM module is installed.

4.4 Fiber Optic Cable Installation

Fiber optic cables and patch cords should be routed to the indoor mounting shelf using existing fiber management systems. All fiber optic connections are made directly with the STM, WDM, or CWDM modules. It is recommended that some provision be made at the mounting shelf for storing excess patch cord slack.

4.5 Antenna Cable Connections

The antenna cable should be routed to the indoor mounting shelf for connection to the STM module. If lightning protection is required, it is recommended that a lightning protector (accessory) be installed near the point where the antenna cable enters the building or enclosure.

4.6 AC Power Wiring and Grounding

A standard three-conductor AC power cord is provided with the indoor mounting shelf for the AC power connections. The receptacle end of the power cable connects to the AC connector on the STM. The plug end of the power cable connects to a standard 120 VAC outlet. If AC power spikes are likely to occur, a surge protector should be installed to protect the equipment from damage. A grounding stud is provided on the left side of the mounting shelf for connecting a separate grounding wire directly to the mounting shelf chassis.

4.7 User Interface

The RU mounting shelf user interface consists primarily of the mounting slots and AC and DC power cables. The user interface points are indicated in [Figure 2-6](#) and described in [Table 2-3](#).

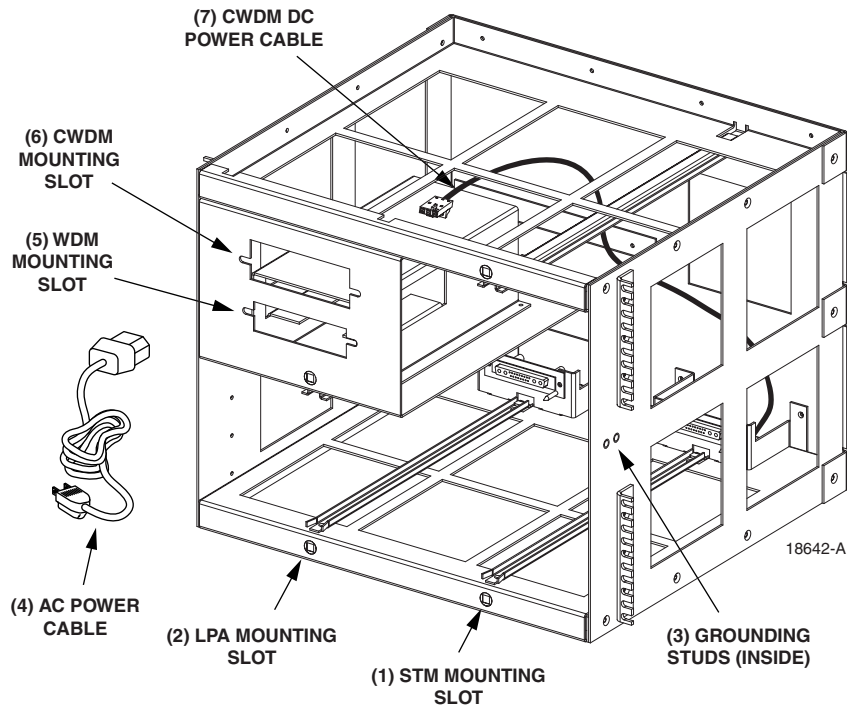

Figure 2-6. Remote Unit Indoor Mounting Shelf User Interface

Table 2-3. Remote Unit Outdoor Mounting Shelf User Interface

REF NO	DEVICE	FUNCTIONAL DESCRIPTION
1	STM mounting slot	Provides a mounting point for the STM module.
2	LPA mounting slot	Provides a mounting point for the LPA module.
3	Grounding lug	Provides a connection point for an external grounding cable.
4	AC power cable	Provides AC power to the STM.
5	WDM mounting slot	Provides a mounting point for the WDM module.
6	CWDM mounting slot	Provides a mounting point for the CWDM module.
7	CWDM power cord	Provides DC power to the CWDM module.

5 SPECTRUM TRANSPORT MODULE

The Spectrum Transport Module (STM), shown in [Figure 2-7](#), provides the following basic functions:

- Provides an RF interface (antenna port) to the remote antenna.
- Provides an optical interface to the HU.
- Converts the digitized forward path optical signal to a digitized RF signal.
- Converts the digitized RF signal to a composite RF signal.
- Digitizes the reverse path composite RF signal.
- Converts the digitized reverse path RF signal to a digitized optical signal.
- Provides an RS-232 interface for connecting a local EMS computer.
- Transports alarm, control, and monitoring information to the HU via the optical link.
- Provides an AC power interface.
- Provides an external alarm interface.

5.1 Primary Components

The STM consists of an electronic circuit board assembly, power supply, duplexer, and fan assembly that are mounted within a powder-paint coated sheet metal enclosure. The metal enclosure provides a mounting point for the electronic components and also controls RF emissions. Except for the fan unit, the electronic components are not user replaceable. The STM is designed for use within the RU outdoor cabinet or indoor mounting shelf. Except for the LPA interface connector, all controls, connectors, indicators, and switches are mounted on the STM front panel for easy access. A carrying handle is provided on the front of the STM to facilitate installation and transport.

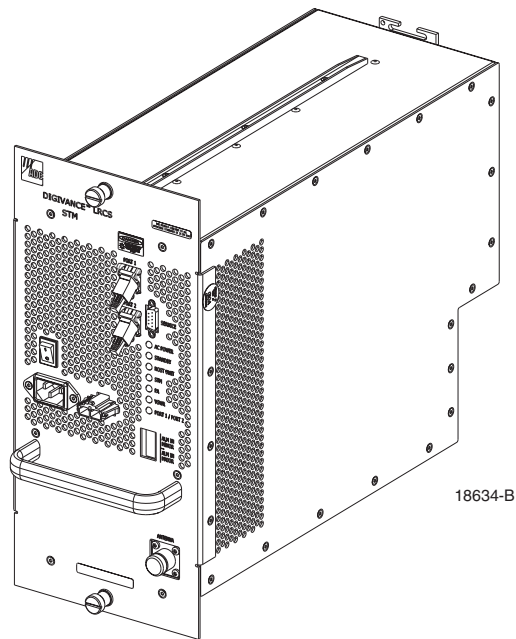

Figure 2-7. Spectrum Transport Module

5.2 Mounting

The STM mounts within the RU outdoor cabinet or indoor mounting shelf. A runner on the bottom of the STM meshes with a track. The runner and track guide the STM into the installed position. The electrical interface between the STM and LPA is supported by a D-sub female connector located on the rear side of the STM. A corresponding D-sub male connector mounted at the rear of the RU cabinet or RU mounting shelf mates with the STM connector. Captive screws are provided for securing the STM in the installed position.

5.3 Fault Detection and Alarm Reporting

The STM detects and reports various faults including remote unit fault, optical fault, power fault, temperature fault, power amplifier fault, and external (door open) fault. Various front panel Light Emitting Diode (LED) indicators turn from green to red or yellow if a fault is detected. The status of the STM, the alarm state (major or minor), and other alarm information is summarized and reported over the optical interface to the HU and also over the service interface. In addition, the alarm state of the HU is received over the optical interface and reported to the service interface. This information may be accessed remotely through the NOC/NEM interface or locally through the EMS software GUI.

5.4 Antenna Cable Connection

The antenna cable connections between the STM and the antenna are supported through one N-type female connector which carries both the forward and reverse path RF signals. When installed in the RU outdoor cabinet, the STM does not connect directly to the antenna but

instead connects to a lightning protector that is mounted on the bottom of the cabinet (see [Section 3.6](#)). A coaxial jumper cable is provided (included with the enclosure) for connecting the STM to the lightning protector.

5.5 RF Signal Level Adjustment

The STM is equipped with a digital attenuator for adjusting the signal level of the forward path RF **output** signal. The **remote forward path** attenuator adjusts the level of the output RF signal at the RU antenna port and will add from 0 to 31 dB of attenuation to the output signal level. The attenuator can be set in 1 dB increments. The attenuator is software controlled and is adjusted through the NOC/NEM interface or the EMS software GUI.

5.6 Optical Connection

Fiber optic connections between the STM and the HU are supported through two SC-type optical connector ports. One port is used for connecting the forward path optical signal and the other port is used for connecting the primary reverse path optical signal.

5.7 Service Interface Connection

The service interface connection between the STM and a local laptop computer loaded with the EMS software is supported by a single DB-9 female connector. The service interface connector provides an RS-232 DTE interface. The STM service interface connector supports local communications with both the STM and the corresponding HU.

5.8 Powering

The STM is powered by 120 or 240 VAC (50 or 60 Hz) power which is supplied through a three-conductor AC power cord. The power cord is provided with the RU outdoor cabinet or indoor mounting shelf. The power cord connects to an AC connector mounted on the STM front panel. A switch on the STM front panel provides AC power On/Off control.

5.9 Cooling

Continuous air-flow for cooling is provided by a single fan mounted on the rear side of the STM housing. An alarm is provided that indicates if a high temperature condition (>50° C/122° F) occurs. If the temperature falls below 32° F (0° C), the fan automatically shuts off. The fan may be field replaced if it fails.

5.10 User Interface

The STM user interface consists of the various connectors, switches, and LEDs that are provided on the STM front panel. The STM user interface points are indicated in [Figure 2-8](#) and described in [Table 2-4](#).

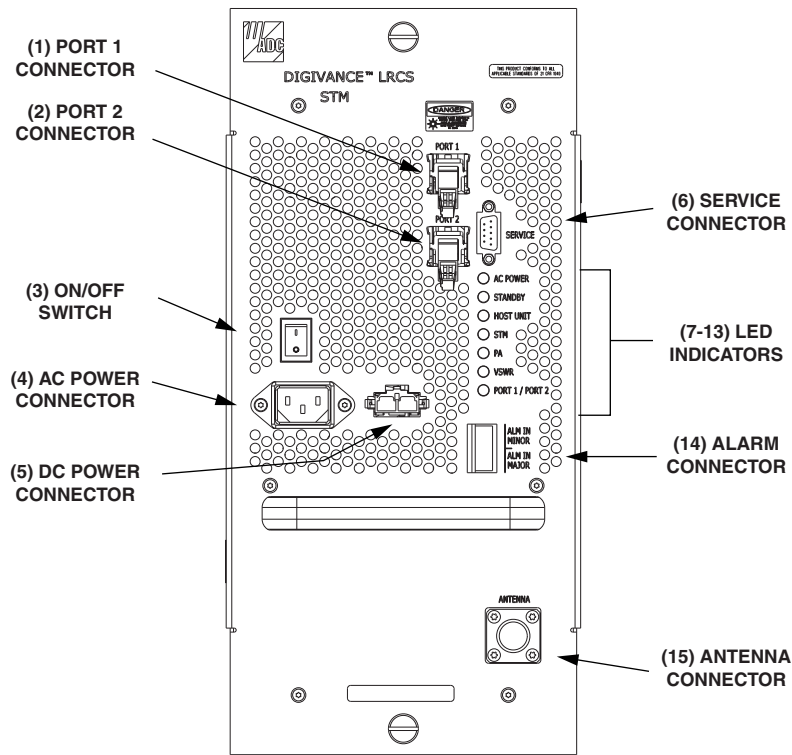

18636-B

Figure 2-8. Spectrum Transport Module User Interface

Table 2-4. Spectrum Transport Module User Interface

REF NO	USER INTERFACE DESIGNATION	DEVICE	FUNCTIONAL DESCRIPTION
1	PORT 1	SC connector (single-mode)	Input connection point for the forward path optical fiber.
2	PORT 2	SC connector (single-mode)	Output connection point for the reverse path primary optical fiber.
3	I/O	On/Off rocker switch	Provides AC power on/off control.
4	No designation	3-wire AC power cord connector	Connection point for the AC power cord.
5	No designation	2-wire DC power cord connector	Connection point for a back-up battery power cord. (Not used with 20 Watt system)
6	SERVICE	DB-9 connector (female)	Connection point for the RS-232 service interface cable.
7	AC POWER	Multi-colored LED (green/red)	Indicates if the STM is powered by the AC power source (green) or the back-up battery system (red). See Note.

Table 2-4. Spectrum Transport Module User Interface, continued

REF NO	USER INTERFACE DESIGNATION	DEVICE	FUNCTIONAL DESCRIPTION
8	STANDBY	Multi-colored LED (green/yellow/red)	Indicates if the system is in the Normal state (off) Standby state (blinking green), Test state (blinking red), or Program Load state (blinking yellow). See Note.
9	HOST UNIT	Multi-colored LED (green/yellow/red)	Indicates if no alarm (green), a minor alarm (yellow), or a major alarm (red) is reported by the HU. See Note.
10	STM	Multi-colored LED (green/yellow/red)	Indicates if the STM is normal (green) or faulty (red). See Note.
11	PA	Multi-colored LED (green/yellow/red)	Indicates if the power amplifier is normal (green), over temperature (yellow), has a fan failure (yellow), or is faulty (red). See Note.
12	VSWR	Multi-colored LED (green/yellow/red)	Indicates if the forward path VSWR is above (red) or below (green) the fault threshold.
13	PORT 1/PORT 2	Multi-colored LED (green/red)	Indicates if the forward/reverse path optical signal from the STM/HU are normal (green), if no optical signals are detected (red), or if excessive errors are detected (red). See Note.
14	ALARM IN MINOR ALARM IN MAJOR	Screw-type terminal connector (14–26 AWG)	Connection point for two external alarm inputs. The door-open switch lead wires are typically connected to the major alarm terminals.
15	ANTENNA	N-type female RF coaxial connector	Connection point for the antenna.
Note: A more detailed description of LED operation is provided in Section 5.			

6 LINEAR POWER AMPLIFIER

The Linear Power Amplifier (LPA), shown in [Figure 2-9](#), works in conjunction with the STM to amplify the forward path RF output signal. The STM is interfaced with the LPA through the D-sub connectors and wiring harness located at the rear of the RU cabinet or RU mounting shelf. The RF signal is passed to the LPA for amplification and then passed back to the STM for filtering and output via the STM's ANTENNA port. The STM also supplies DC power to the LPA through the same interface.

6.1 Primary Components

The LPA consists of a fan and several electronic circuit board assemblies that are mounted within a powder-paint coated sheet metal enclosure. The metal enclosure provides a mounting point for the electronic components and also controls RF emissions. Except for the fan unit, the electronic components are not user replaceable. The LPA is designed for use within the RU outdoor cabinet or RU indoor mounting shelf. Except for the STM interface connector, all controls, indicators, and switches are mounted on the LPA front panel for easy access. A carrying handle is provided on the front of the LPA to facilitate installation and transport.

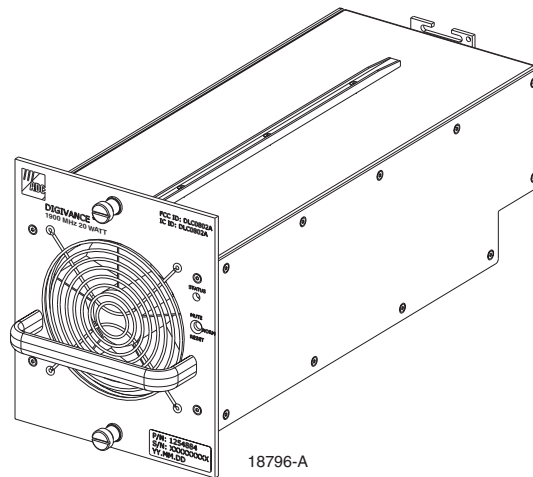

Figure 2-9. Linear Power Amplifier

6.2 Mounting

The LPA mounts within the RU outdoor cabinet or RU indoor mounting shelf. Runners on the top and bottom of the LPA mesh with tracks. The runners and tracks guide the LPA into the installed position. The electrical interface between the STM and LPA is supported by a D-sub female connector located on the rear side of the LPA. A corresponding D-sub male connector mounted at the rear of the RU outdoor cabinet or RU indoor mounting shelf mates with the LPA connector. Captive screws are provided for securing the LPA in the installed position.

6.3 Fault Detection and Alarm Reporting

The LPA in conjunction with the STM detects and reports various faults including power amplifier fault, output power fault, temperature fault, and fan fault. A single Light Emitting Diode (LED) indicator, located on the front panel of the LPA, turns from green to red or yellow if an LPA fault is detected. The status of the LPA, the alarm state (major or minor), and other information is summarized and reported (by the STM) over the optical fiber to the HU and also to the service interface. This information may be accessed remotely through the NOC/NEM interface or locally through the EMS software GUI.

6.4 Powering

The LPA is powered by various DC voltages which are supplied by the STM over the electrical interface provided by the D-sub connectors and wiring harness mounted within the RU outdoor cabinet or RU indoor mounting shelf.

6.5 Cooling

Continuous air-flow for cooling is provided by a fan mounted at the front of the LPA housing. Cool air is pulled into the module from the front and heated air is exhausted out the back. An alarm is provided that indicates if a high temperature condition (>50° C/122° F) occurs or if a fan failure occurs. The fan may be field replaced if it fails.

6.6 User Interface

The LPA user interface consists of an LED indicator and a switch that are mounted on the LPA front panel. The LPA user interface points are described in [Table 2-5](#) and indicated in [Figure 2-10](#).

Table 2-5. Linear Power Amplifier User Interface

REF NO	USER INTERFACE DESIGNATION	DEVICE	FUNCTIONAL DESCRIPTION
1	STATUS	LED indicator (green, yellow, and red)	Indicates the operational state of the LPA and whether or not there are any faults.
2	MUTE NORM RESET	3-position switch with one momentary contact position	Placing the switch in the MUTE position puts the LPA in the shutdown state with RF output disabled. With the switch in MUTE, the STM can not control the LPA output power. Placing the switch in the NORM position puts the LPA in the normal state and allows the STM to enable and disable the RF output. Momentarily placing the switch in the RESET position clears all alarms and restarts the LPA.

Note: A more detailed description of the STATUS LED is provided in Section 5.

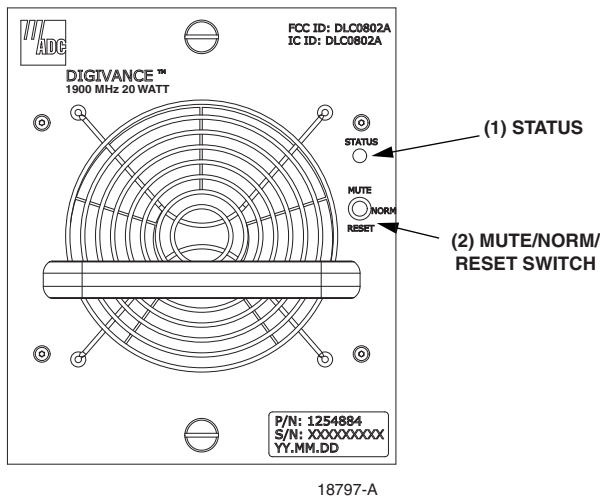

Figure 2-10. Linear Power Amplifier User Interface

7 INTERFACE PANELS (ACCESSORY)

The interface panels are accessory items that are used when multiple BTS's and multiple HU's require connection or when RF attenuation is needed between the BTS and HU. Two types of panels are available: the Conditioning Panel and the Duplexing Panel. The Conditioning Panel, shown in [Figure 2-11](#), provides attenuation of the forward path signal to the level required for input to the HU. The Conditioning Panel also provides forward and reverse path combining and splitting (as needed) to enable multi-BTS to single HU, multi-BTS to multi-HU, or single BTS to multi-HU configurations.

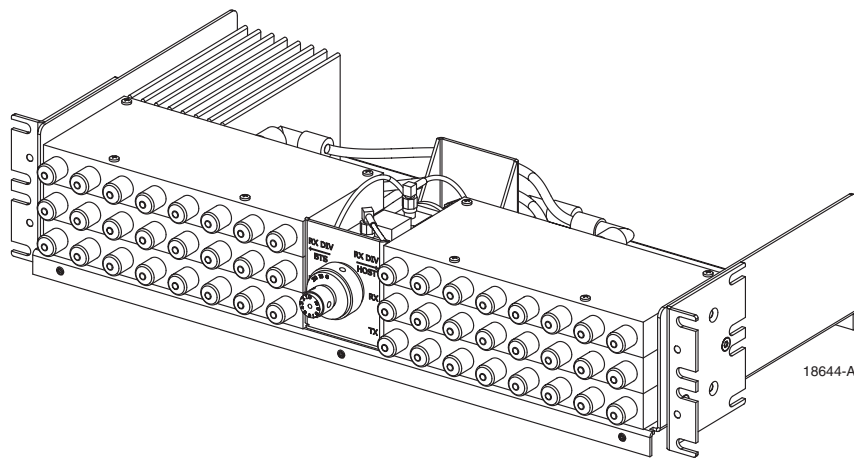

Figure 2-11. Conditioning Panel

The Duplexing Panel, shown in [Figure 2-12](#), is used in conjunction with the Conditioning Panel when the BTS provides a duplexed forward and reverse path RF connection. The Duplexing Panel separates the duplexed forward and reverse path signals. This allows the BTS to be connected to the HU which has separate forward and reverse path RF ports. For complete information about the Conditioning Panel and Duplexing Panel, refer to the Digivance RF Transport Solution 800 and 1900 MHz Interface Panels User Manual (ADCP-75-144).

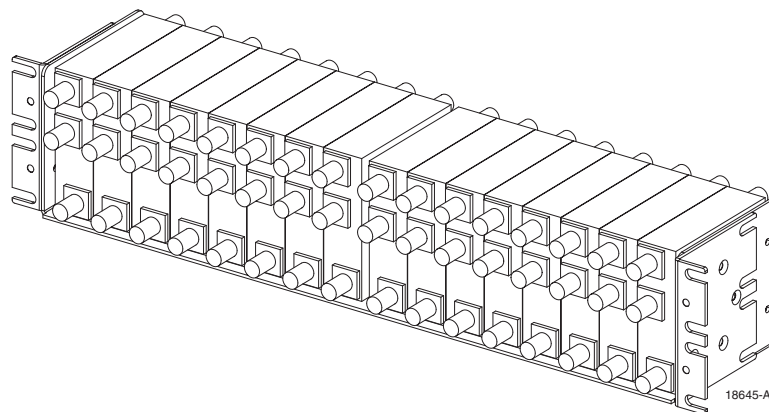

Figure 2-12. Duplexing Panel

8 WAVELENGTH DIVISION MULTIPLEXER SYSTEM (ACCESSORY)

The Wavelength Division Multiplexer (WDM) system is an accessory product that is used when it is desirable or necessary to combine the forward and reverse path optical signals from one Digivance system onto a single optical fiber. Each WDM system consists of a host module, host module mounting shelf, and remote module. The WDM host module mounting shelf can support two WDM host modules. The RU indoor mounting shelf provides a mounting slot for installing a WDM remote module.

Each WDM module consists of either one (remote module) or two (host module) bi-directional wavelength division multiplexers mounted within a power-paint coated sheet metal enclosure. An SC-type optical connector port is provided for connecting the forward/reverse path optical fiber to the WDM module. A pair of pigtail leads with SC-type connectors are provided for connecting the WDM module to the forward and reverse path optical ports on the HU or STM.

The WDM host module and host module mounting shelf are shown in [Figure 2-13](#). The WDM remote module is shown in [Figure 2-14](#).

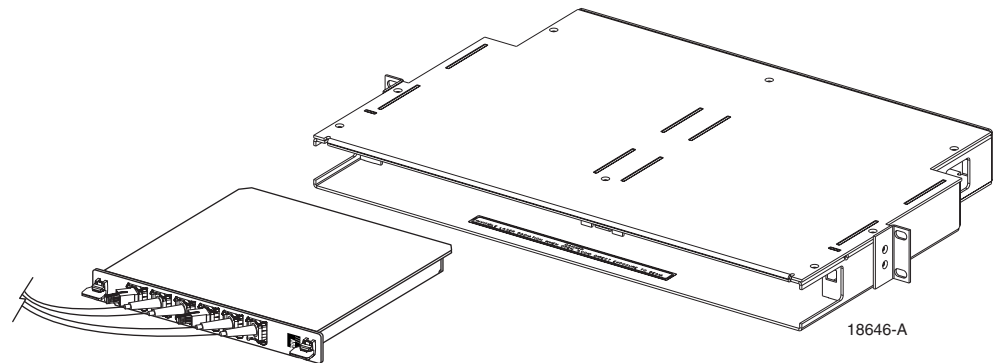

Figure 2-13. WDM Host Module and Host Module Mounting Shelf

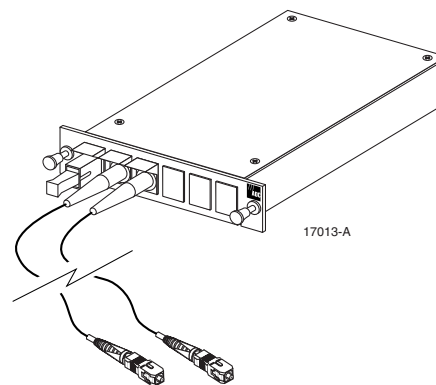

Figure 2-14. WDM Remote Module

9 COARSE WAVELENGTH DIVISION MULTIPLEXER SYSTEM (ACCESSORY)

The Coarse Wavelength Division Multiplexer (CWDM) system is an accessory product that is used when it is desirable or necessary to combine the forward and reserve path optical signals for up to four Digivance systems onto a single optical fiber. Each CWDM system consists of a Host Module, Host Module mounting shelf, and Remote Module. The CWDM Host Module mounting shelf can support up to three CWDM Host Modules. Both the RU outdoor cabinet and indoor mounting shelf provide a mounting slot for installing a CWDM Remote Module.

The CWDM Host Module and Host Module Mounting Shelf are shown in [Figure 2-15](#). The CWDM Remote Module is shown in [Figure 2-16](#). For complete information about the CWDM system, refer to the Digivance System Coarse Wavelength Division Multiplexer User Manual (ADCP-75-142).

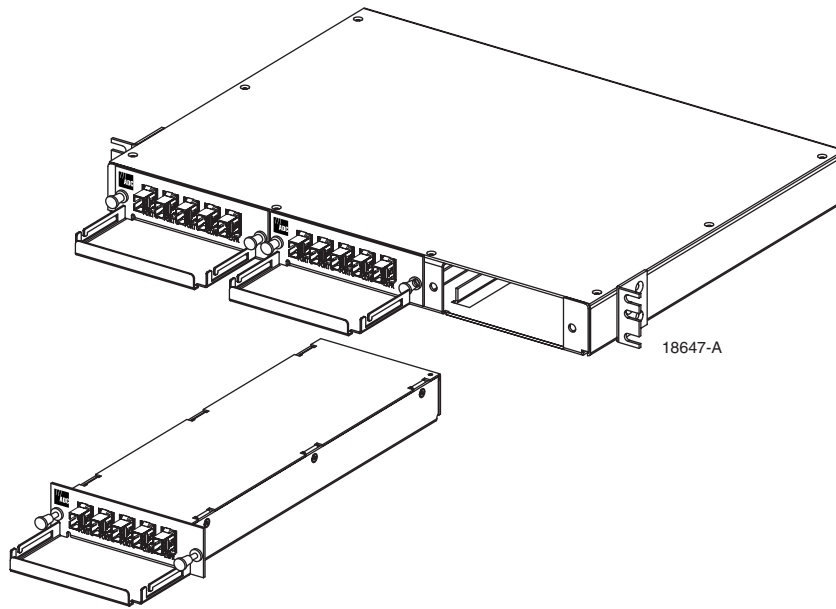

Figure 2-15. CWDM Host Module and Host Module Mounting Shelf

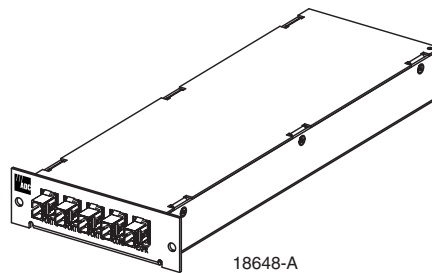

Figure 2-16. CWDM Remote Module

10 DIGIVANCE ELEMENT MANAGEMENT SYSTEM

The Digivance Element Management System (EMS) is a network management tool that provides control and monitoring functions for the Digivance system. The EMS is used to provision and configure new systems for operation, set system operating parameters, get system alarm and status messages, and upgrade the system software. The EMS supports both local control by an on-site service technician and remote control by a Network Operations Center (NOC).

10.1 Primary Components

The EMS, shown in [Figure 2-17](#), consists of a PC-type desk-top computer (not provided) that is loaded with the EMS software. The EMS software is stored on a CD-ROM that is shipped separately along with a User Manual and mouse pad. The EMS software must be installed on the EMS computer along with the Java 2 Version 1.3.1 Runtime Environment software which is also provided. Installation consists of inserting the CD-ROM into the computer's CD-ROM drive and then running the software install programs. This places the Java 2 Runtime Environment and EMS software files in assigned folders on the computer's hard drive.

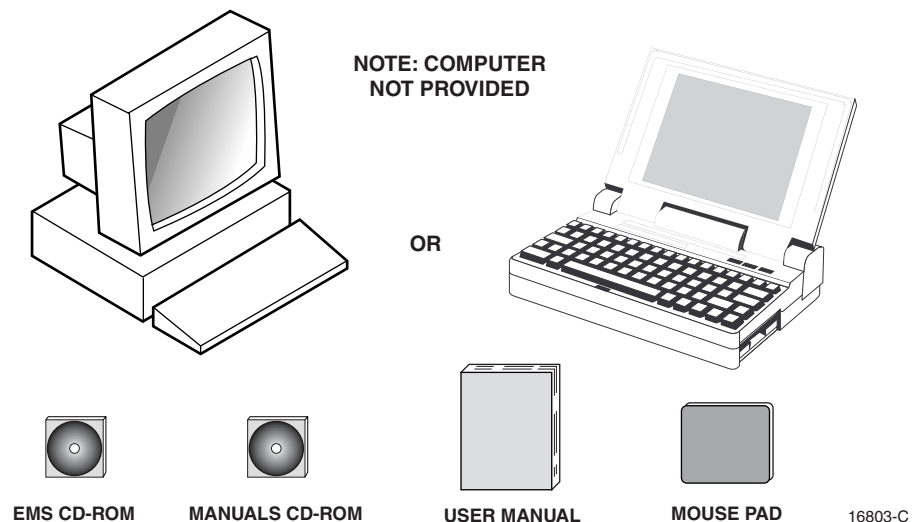

Figure 2-17. Digivance Element Management System

The EMS software may also be installed on a PC-type lap-top computer (not provided). A lap-top version of the EMS computer can be used as a portable network management tool for service and maintenance purposes. A laptop EMS computer can be connected temporarily to a system to enter the initial configuration data or to trouble-shoot problems and then removed when the task is completed. Permanent control and monitoring functions would be provided by the desk-top EMS computer.

10.2 Service Interface Connection

The service interface connection between the EMS computer and the HU or RU requires that the EMS computer be equipped with a DB-9 connector that is configured to provide an RS-232 DCE interface. A straight-through RS-232 interface cable (accessory item) equipped with a male DB-9 connector on one end and a PC-compatible connector on the other end is required to link the EMS computer to the HU. When multiple HUs are networked together, the EMS computer may be connected to the service connector on any one of the networked HUs.

10.3 NOC Interface Connection

The NOC interface connection between the EMS computer and the NOC requires that the EMS computer be equipped with a connector that is configured to provide an RS-232 ASCII interface. The link between the EMS computer and the NOC would generally be supported by a data network. Cables and equipment (not provided) to support the RS-232 interface connection between the EMS computer and the data network are required.

10.4 EMS Software User Interface

The EMS software provides two user interfaces: the Graphical User Interface (GUI) and the Network Operation Center-Network Element Manager (NOC/NEM) interface. Both interfaces provide essentially the same functionality except only the GUI can upgrade the Digivance system with new system software. In addition, only the NOC/NEM interface can record and play back alarm data.

The GUI is presented at the EMS computer or on a laptop computer. The GUI is used for **local** control and monitoring operations. The GUI consists of a series of displays and screens, such as the one shown in [Figure 2-18](#), that provide the user with alarm and status information and that allow the user to set various operating parameters.

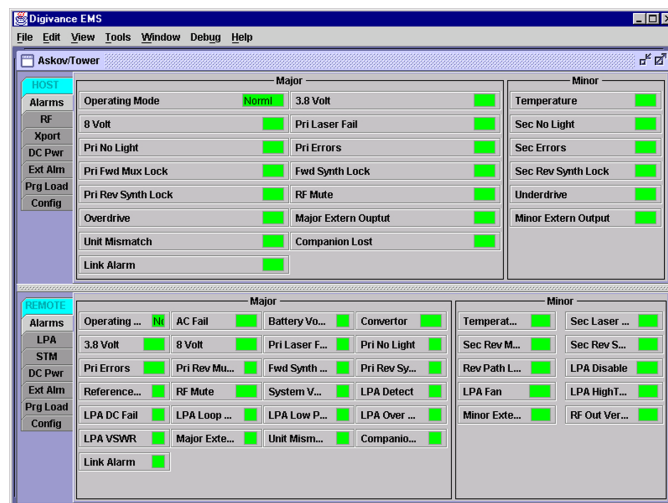

Figure 2-18. EMS Graphical User Interface Host/Remote Display