

Figure 3. Digital Host Unit User Interface

2.2 Digital Remote Unit Description

The DRU, shown in Figure 4, serves as the cellular-user servicing unit for the Digivance ICS. The DRU provides the following basic functions:

- RF interface to the cellular users via an external antenna
- Optical interface to the DHU or DEU
- Conversion of the forward path digitized optical signal to a digitized RF signal
- Conversion of the digitized forward path RF signal to the original cellular RF signal
- Digitizing of the cellular reverse path RF signal
- Conversion of the digitized reverse path RF signal to a digital optical signal output
- Transports alarm status over the reverse path optical fiber

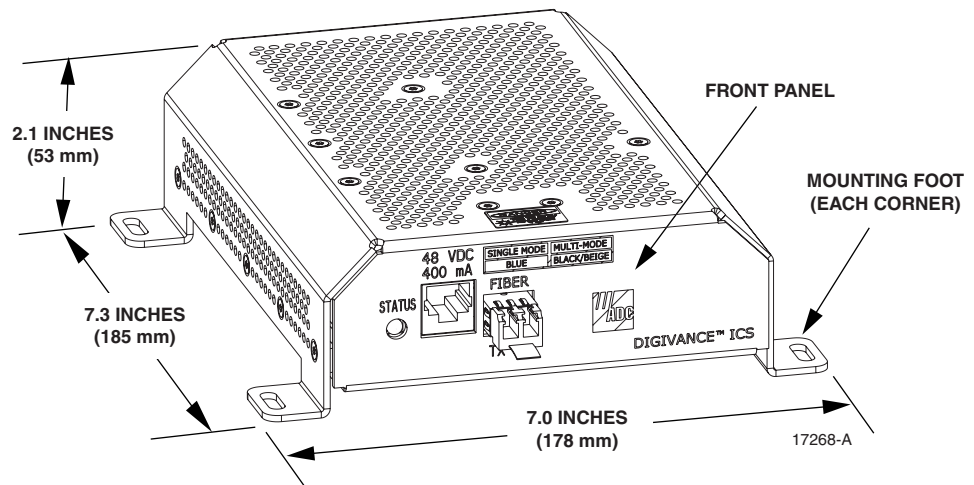

Figure 4. Digital Remote Unit

2.2.1 Primary Components

The DRU consists of an electronic circuit board assembly that is mounted within a powder-coated sheet metal enclosure. The metal enclosure provides a mounting point for the electronic assembly, serves as a heat sink, and controls RF emissions. Except for the optical transceiver, the DRU components are not field replaceable. The DRU is designed for use within a non-condensing indoor environment such as inside a building. All controls, connectors, and indicators (except the SMA antenna connector) are mounted on the DRU front panel for convenient access.

2.2.2 Mounting

The DRU is equipped with four integral mounting feet that allow it to be mounted on any flat horizontal or vertical surface. A typical location for mounting the DRU would be on a ceiling or a wall. The DRU may also be installed in spaces used for environmental air such as the space over a suspended ceiling or beneath a raised floor. Slots are provided in the mounting feet for securing the DRU to the mounting surface.

2.2.3 Fault Detection

The DRU detects internal circuitry faults or loss of system inputs. A front panel LED indicator turns from green to red when a fault condition is detected or when the optical input is lost. The DRU sends the fault information to the DHU or DEU over the reverse path optical fiber. A corresponding port LED at the DHU or DEU turns from green to red when the DRU reports a fault.

2.2.4 Antenna Connection

The RF signal interface between the DRU and the cellular users is provided through an external antenna. An SMA connector is provided for connecting the DRU to the antenna. The antenna must be ordered separately. Several types of antennas with various RF propagations are available. Non-ADC antennas may also be used with the DRU to meet various application requirements.

2.2.5 Optical Port

The DRU is equipped with a small form factor LC-type optical transceiver for connecting the optical fibers. Each transceiver is color-coded to identify whether it supports single-mode (blue) or multi-mode (black/beige) fiber. Depending on the application requirements, the optical port may be connected to either a DHU or a DEU. The modular optical transceiver is available separately as an accessory item and is field replaceable.

2.2.6 Powering

The DRU is equipped with a female RJ-45 jack that provides a connection point for the DC power cable. The DRU is powered by 34–48 Vdc power which is supplied through the RJ-45

connector. Power to the DRU may be supplied by the DHU, DEU, or by a 120 Vac to 48 Vdc power converter (available separately as an accessory item) plugged into a properly grounded 120 Vac outlet. The ac/dc converter is a UL Listed stand-alone Limited Power Supply (LPS) unit with a rated output of 48 Vdc at 1.2 Amps. When powered by the DHU or DEU, a category 3 or 5 twisted-pair cable terminated with RJ-45 connectors is required.

2.2.7 Cooling

The DRU is cooled by natural convection air flow. The DRU mounting feet are designed to provide clearance under the unit so that air can enter the DRU enclosure from the bottom and exit through the top. A minimum clearance of 3 inches (76 mm) must be provided on all sides of the DRU (except the bottom) to ensure there is adequate air circulation for cooling. In addition, at least one surface of the DRU installation area must be open to the interior of the building.

2.2.8 User Interface

The DRU user interface consists of the connectors and the LED that are provided on the DRU front and rear panels. The DRU user interface points are described in Table 2 and indicated in Figure 5.

Table 2. Digital Remote Unit User Interface

REF No.	USER INTERFACE DESIGNATION	DEVICE	FUNCTIONAL DESCRIPTION
1	STATUS	Multi-colored LED (Red/Green/Yellow)	Indicates if the status of the DRU is normal or faulty or if the forward path optical input is normal or lost. (see Note)
2	48 VDC	RJ-45 jack (female)	Used for connecting a DC power cable.
3	FIBER TX RX	LC-type optical transceiver	Used for connecting the forward path and reverse path optical fibers.
4	–	SMA-type coaxial connector (female)	Used for connecting the antenna coaxial cable lead.

Note: A more detailed description of LED operation is provided in Section 5.

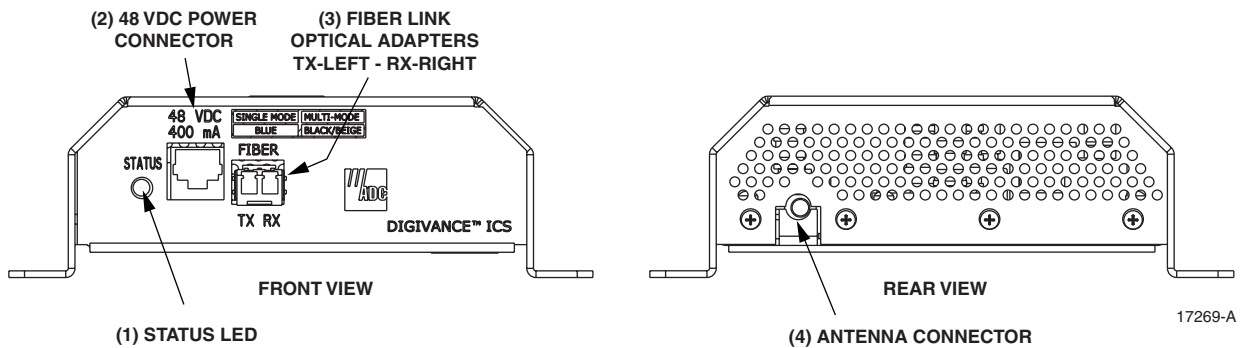

Figure 5. Digital Remote Unit User Interface

2.3 Digital Expansion Unit Description

The DEU, shown in Figure 6, serves as a service expansion unit and line extender for the Digivance ICS. The DEU provides the following basic functions:

- Optical interface to the DHU and up to six DRU's or DEU's
- Conversion of the forward path digitized optical signal to an electrical bit stream
- Splitting of the electrical bit stream into six separate bit streams
- Conversion of the six forward path electrical bit streams into six digital optical signals
- Conversion of up to six reverse path digital optical signals into six serial bit streams
- Combining of the six reverse path serial bit streams into a single digital composite signal
- Conversion of the single digital composite signal to a digital optical signal
- DC power for powering the DRU's
- Alarm transport via the optical fibers

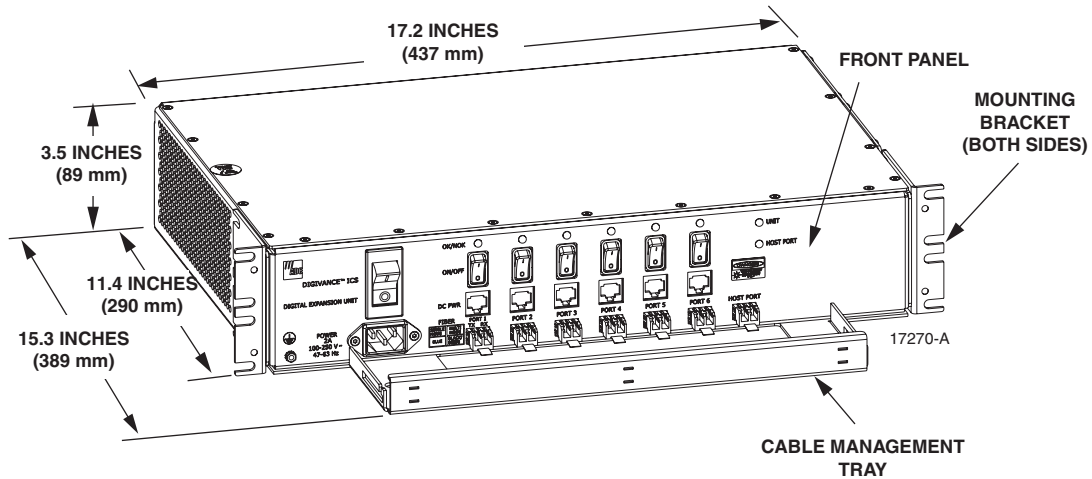

Figure 6. Digital Expansion Unit

2.3.1 Primary Components

The DEU consists of two electronic circuit board assemblies and a power supply that are mounted within a powder-coated sheet metal enclosure. The metal enclosure provides a mounting point for the electronic assemblies and serves as a heat sink. Except for the fan units and optical transceivers, the DEU components are not field replaceable. The DEU is designed for use within a non-condensing indoor environment such as inside a wiring closet or cabinet. All controls, connectors, and indicators are mounted on the DEU front panel for convenient access. Cable management functions for the power and fiber optic cables are provided by a cable management tray that extends outward from the DEU front panel.

2.3.2 Mounting

The DEU may be used in both rack-mount and wall-mount applications. For rack mount applications, a pair of reversible mounting brackets is provided that allow the DEU to be

mounted in either a 19-inch or 23-inch EIA or WECO equipment rack. When rack-mounted, the front panel of the DEU is flush with the front of the rack and the cable management tray extends 3.9 inches (99 mm) beyond the front panel. For wall-mount applications, a pair of holes is provided in the cable management tray which allow the DEU to be mounted on any flat vertical surface. The DEU should be oriented with the front panel facing upward when wall-mounted. Fasteners are provided for rack-mount applications.

2.3.3 Fault Detection

The DEU detects internal circuitry faults or loss of system inputs. Various front panel Light Emitting Diode (LED) indicators turn from green to red or yellow when a fault is detected or when an optical input is lost. The DEU transports the fault information to the DHU or supporting DEU over the reverse path optical fiber. A corresponding port LED at the DHU or DEU turns from green to red when the DEU reports a fault.

2.3.4 Optical and Electrical Connections

The optical and electrical connections with the DRU's and DEU's are supported by six optical and six electrical ports. Each optical and electrical port includes a status LED, a small form factor LC type optical transceiver, an RJ-45 DC power jack, and a port enable/disable switch. Each transceiver is color-coded to identify whether it supports single-mode (blue) or multi-mode (black/beige) fiber. An optical port may be connected to a DRU, a DEU, or not used. An electrical port may be connected to a DRU or not used. Unused ports are disabled via the corresponding port enable/disable switch. When disabled, the port LED is off, the alarm reporting function is disabled, the laser is off, and the DC power is off. Enabling the enable/disable switch activates all functions. The DEU also provides one optical port (designated as the host port) for the optical interface with the DHU or a supporting DEU. The modular optical transceivers are available separately as accessory items and are field replaceable.

2.3.5 Powering

The DEU is powered by 120–240 Vac (50–60 Hz) power which is supplied through a standard three-conductor AC power cord. The power cord is provided with the DEU and is 98 inches (2.5 meters) long. A resettable circuit breaker/On-Off switch is provided at the unit front panel. The switch applies power to the DEU internal power supply.

2.3.6 Cooling

Continuous air flow for cooling is provided by dual fans mounted on the right side of the sheet metal housing. A minimum of 3 inches (76 mm) of clearance space must be provided on both the left and right sides of the DEU for air intake and exhaust. An alarm is provided that indicates if a high temperature condition (>50° C/122° F) occurs. The fans may be field-replaced if either unit fails.

2.3.7 User Interface

The DEU user interface consists of the various connectors, switches, and LEDs that are provided on the DEU front panel. The DEU user interface points are described in Table 3 and indicated in Figure 7.

Table 3. Digital Expansion Unit User Interface

REF No.	USER INTERFACE DESIGNATION	DEVICE	FUNCTIONAL DESCRIPTION
1		Grounding stud	Used for connecting a grounding cable to the DEU chassis.
2	POWER	3-wire AC power cord connector	Used for connecting the AC power cord.
3	I/O	I/O rocker switch/circuit breaker	Provides AC power On/Off control and AC power over current protection.
4	OK/NOK (Ports 1–6)	Multi-colored LED (Red/Green/Yellow)	Indicates if the DRU or remote DEU connected to the optical port is normal or faulty or if the reverse path optical input from the DRU or remote DEU is normal or lost. (see Note)
5	ON/OFF (Ports 1–6)	I/O rocker switch	Enables or disables corresponding electrical and optical ports.
6	DC PWR (Ports 1–6)	RJ-45 jack (female)	Used for connecting a DRU cat 3 or 5 power cable to the designated DC power jack.
7	FIBER (Ports 1–6)	LC-type optical transceiver	Used for connecting each DRU or remote DEU forward path and reverse path optical fiber to the designated optical port.
8	HOST PORT	LC-type optical transceiver	Used for connecting the DHU or supporting DEU forward path and reverse path optical fiber.
9	UNIT	Multi-colored LED (Red/Green/Yellow)	Indicates if the DEU is normal or faulty. (see Note)
10	HOST PORT	Multi-colored LED (Red/Green/Yellow)	Indicates if the forward path optical input from the DHU or supporting DEU is normal or lost. (see Note)

Note: A more detailed description of LED operation is provided in Section 5.

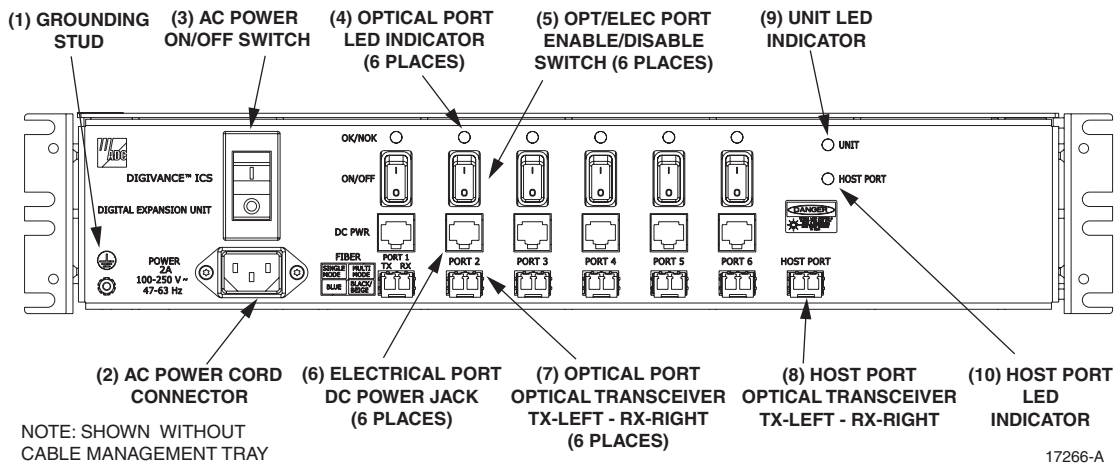

Figure 7. Digital Expansion Unit User Interface

2.4 Terms and Definitions

Refer to Table 4 for a listing of the terms used in this manual and their definition.

Table 4. Terms and Definitions

TERM	DEFINITION
Alarm Response	The response to an alarm input.
Base Transceiver Station	The radio equipment that transmits and receives the voice and control channels to and from the cellular handsets.
Composite Signal	A signal that is the sum of several signals.
Digital Expansion Unit	The unit that extends a single optical interface to multiple optical interfaces or that extends an optical run.
Digital Host Unit	The unit that converts and provides the digital source signal to all DEU's and DRU's and converts summed inputs from DEU's and DRU's.
Digital Remote Unit	The unit that interfaces the in-building user to the Digivance optical transport.
Digitized RF Signal	The RF signal in a digitized form.
Forward Path Signal	A signal that travels from the base station to the cell phone.
Major Alarm	An alarm condition that applies when any fault (except high temperature) occurs.
Minor Alarm	The alarm condition that applies when a high temperature condition occurs. (> 50° C/122° F)
Mute	To force a forward path RF signal to a "no signal" state.
Normal State	The operating state after power-up is completed and no faults are detected.
Port	An RF, optical, or electrical interface point.
Port Alarm	A fault that affects only the unit or units connected to that port. Indicates no optical input to port.
Power-Up State	The period between the application of power to a unit and the normal state. This period includes time for circuit stabilization and initialization operations.
Reverse Path Signal	A signal that travels from one or more cell phones to the base station.
Transport Alarm Signal	An alarm signal transported over the reverse path optical fiber.
Unit Alarm	A fault within a unit that usually affects all connected ports.

2.5 Specifications

Refer to Table 5 for the Digivance ICS system specifications. **All specifications apply after a five minute warm-up period.**

Table 5. System Specifications

PARAMETER	SPECIFICATION	REMARKS
Optical – All Units		
Fiber type	Multi-mode: 50 or 62.5 micron core Single-mode: 9 micron core	Two fibers per transport link
Maximum fiber length for guaranteed performance	500 m (1,641 ft) 750 m (2461 ft) 10 km (32,808 ft)	With 62.5 micron core MM fiber With 50 micron core MM fiber With 9 micron core SM fiber
Optical output power	-10 to -3 dBm	
Optical wavelength	850 nm for multi-mode use 1310 nm for single-mode use	
Environmental		
Operating temperature	0° to 50° C (32° to 122° F)	
Storage temperature	-30° to +70° C (-22 to 158° F)	
Humidity	No condensation	
Weather resistance	NEMA type 2, IEC 529 IP30	Indoor installation only
RF Forward Path		
System bandwidth	18 MHz	
Frequency range	851 to 869 MHz	
Output power	> +13 dBm	Maximum composite power
Gain	+33 dB nominal	At room temperature
Gain variation	≤ 6 dB < 1.5 dB variation per 1.25 MHz CDMA channel	Over frequency, temperature, and unit to unit. May have up to 2 dB variation at upper band edge.
OIP3	+35 dBm typical	At max. composite output power
CDMA ACPR1	≤ -45 dBc	
Spurious Output	≤ -30 dBm	
DHU RF input signal level	-20 dBm maximum composite	Provides maximum output power level at the DRU
RF Reverse Path		
System bandwidth	18 MHz	
Frequency range	806 to 824 MHz	
Gain	+10 dB nominal	
Gain Variation	≤ 6 dB < 1.5 dB variation per 1.25 MHz CDMA channel	Over frequency, temperature, and unit to unit.
Automatic Gain Limiting	Enabled for composite RF input ≥ -40 dBm	Prevents A/D saturation with large inputs.
Noise Figure	≤ 9 dB + 10 log N where N = # of remotes	≤ 9 dB typical. See Note at end of table.
DHU RF output signal level	-30 dBm maximum	With a -40 dBm composite maximum input signal at the DRU

(continued)

Table 5. System Specifications, continued

PARAMETER	SPECIFICATION	REMARKS
Physical/Electrical – DHU		
Weight	18.5 lbs (8.4 kg)	
RF connection	Type N	Female
Alarm connection	Screw terminals (14–26 AWG)	NO, NC, and COM (form C relay contacts)
Optical connection	Duplex LC transceiver	
DC power output connection	RJ-45	Female
Power input	120/240 Vac, 50–60 Hz	
AC power connection	IEC 320	Male
Power consumption	250 W	Maximum
Current rating	85–250 Vac, 2 Amp input	
Physical/Electrical – DEU		
Weight	18.5 lbs (8.4 kg)	
Optical connection	Duplex LC transceiver	
DC pwr output connection	RJ-45	Female
Power input	120/240 Vac, 50–60 Hz	
AC power connection	IEC 320	Male
Power consumption	250 W	Maximum
Current rating	85–250 Vac, 2 Amp input	
Physical/Electrical – DRU		
Weight	1.5 lbs (708 g)	
RF connection	SMA	Female
Antenna types	Ceiling mount omni directional 90° directional panel Ceiling mount hallway	2.5 dBi gain 7.5 dBi gain 4 dBi gain
Optical connection	Duplex LC transceiver	
DC pwr input connection	RJ-45	Female
Power input	34 to 48 Vdc	
DC power cable length (Cat-3 or -5 cable)	500 meters (1,641 ft) maximum	Any distance beyond 500 meters requires alternate power sourcing
Power consumption	17 W	Typical
Current rating	48 Vdc, 400 mA input	

Note: The noise from all remotes is added at the host. Given N units with identical gain and noise, the formula applies exactly. Slight unit to unit noise figure and gain variations make this a very useful approximation.

3 INSTALLATION PLANNING AND SYSTEM DESIGN

This section provides installation planning information and basic system design recommendations for RF engineers that will be designing and installing an in-building coverage solution using the Digivance ICS. System design and planning services are available from ADC if required. Refer to Section 7 of this manual for additional information.

3.1 Base Station Interface Requirements

The DHU may be interfaced either locally or remotely with the BTS. As referenced in this publication, the BTS could be either a microcell or a cell site base station. With a local interface, a hard-wire connection is provided between the DHU and the BTS (microcell) using coaxial cables. With a remote interface, an over-the-air connection is provided between the DHU and the BTS (cell site base station) using a donor antenna.

3.1.1 Local BTS (Microcell) Interface

A local interface between the DHU and the BTS (microcell) over coax requires specific RF input and output signal levels at the DHU and BTS. The correct levels must be provided at the BTS and DHU interface using a local interface device (ancillary product). A block diagram of a typical **local** BTS interface is shown in Figure 8.

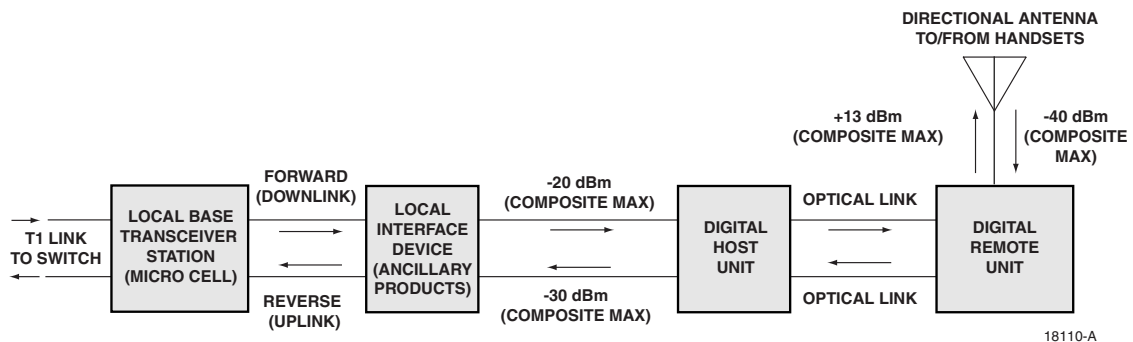

Figure 8. Local BTS Interface Block Diagram

The level of the RF output signal from the BTS varies depending on the type of BTS. Therefore, it will generally be necessary to add some gain or some attenuation to the forward path (downlink) signal. The recommended composite maximum RF input signal level at the DHU is **-20 dBm**. When the level of the RF input signal at the DHU is **-20 dBm**, the level of the RF output signal at the DRU will be **+13 dBm**.

In the reverse path, the input signal level required at the BTS also varies depending on the type of BTS. When the level of the reverse path (uplink) signal at the DRU is at the recommended composite maximum of **-40 dBm**, the level of the RF output signal from the DHU will be **-30 dBm**. Therefore, it may also be necessary to add some gain or attenuation to the reverse path signal in order to provide the input RF signal level required at the BTS.

3.1.2 Remote BTS (Cell Site Base Station) Interface

A remote interface between the DHU and the BTS (cell site base station) via a donor antenna requires specific RF input and output signal levels at the DHU and antenna. The correct levels at the DHU and antenna can be provided using a remote interface device (ancillary product). A block diagram of a typical **remote** DHU to BTS interface is shown in Figure 9.

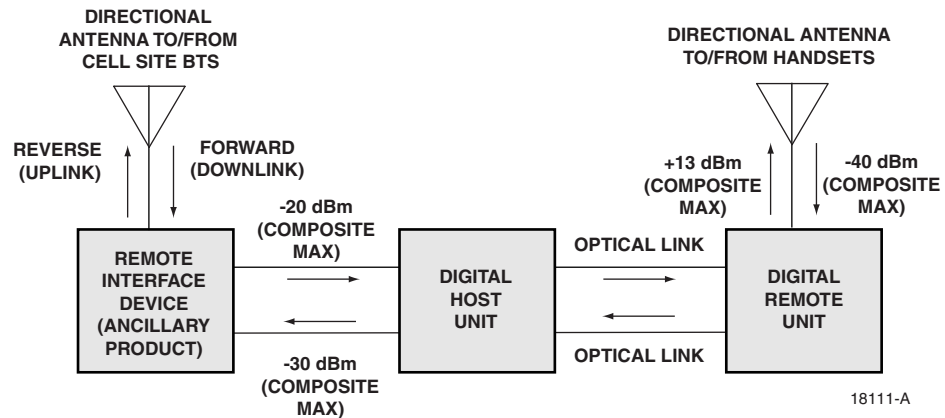

Figure 9. Remote BTS Interface Block Diagram

In the forward path (downlink), the recommended composite maximum RF input signal level at the DHU is **-20 dBm**. When the level of the RF input signal at the DHU is **-20 dBm**, the level of the RF output signal at the DRU will be **+13 dBm**.

In the reverse path, the RF output signal level required at the donor antenna will vary depending on the distance from the BTS. When the level of the reverse path (uplink) signal at the DRU is at the recommended composite maximum level of **-40 dBm**, the level of the RF output signal from the DHU will be **-30 dBm**. Therefore, it will generally be necessary to add some gain to the reverse path signal in order to provide the output RF signal level required at the donor antenna.

3.2 Location and Mounting Requirements

3.2.1 DHU and DEU Location and Mounting Requirements

The DHU and the DEU may be either rack mounted or wall mounted. Fasteners (both metric and US standard) are included with each unit for rack mount applications. A pair of reversible mounting brackets is provided that allows the unit to be mounted in either a 19-inch or 23-inch EIA or WECO equipment rack. When rack-mounted, the front panel of the unit is flush with the front of the rack. The cable management tray extends 3.9 inches (99 mm) beyond the front panel. Both the DHU and DEU occupy 3.5 inches (89 mm) of rack space. Make sure the mechanical loading of the rack will be even to avoid a hazardous condition such as a severely unbalanced rack. The rack should safely support the combined weight of all the equipment it holds and be properly anchored.

For wall-mount applications of the DHU or DEU, a pair of holes is provided in the cable management tray that allows the unit to be mounted on any flat vertical surface. The mounting holes are spaced 11-21/32 inches (296 mm) apart. The DHU/DEU should be oriented so the front panel faces up when mounted. Appropriate fasteners for wall mounting must be provided by the installer. It is recommended that a backer board such as 3/4-inch plywood be installed over the mounting surface to provide a secure base for attaching the DHU or DEU.

The DHU and DEU should be mounted in a non-condensing indoor environment such as inside a wiring closet or within an environmentally controlled cabinet. All controls, connectors, and indicators are mounted on the front panel. All cables should be routed to the front panel for connection. Cable retainers provided on the cable management tray for securing the fiber optic, DC power, and external alarm system cables.

The maximum recommended ambient temperature for the DHU and DEU is 50° C (122° F). Sufficient space for air circulation should be provided between each unit when installed in a multi-unit rack assembly because the operating ambient temperature of the rack environment might be greater than room ambient. A minimum clearance of 3 inches (76 mm) should be provided on both the left and right sides of the unit for air intake and exhaust. Refer to Figure 2 for the DHU dimensions and Figure 6 for the DEU dimensions.

3.2.2 DRU Location and Mounting Requirements

The DRU must be installed in a non-condensing indoor environment and may be wall-mounted or ceiling-mounted. The DRU may also be installed in spaces used for environmental air such as the space over a suspended ceiling or beneath a raised floor. The DRU is equipped with four integral mounting feet that allow it to be fastened to any flat vertical or horizontal surface. Holes are provided in the mounting feet for inserting fasteners. Appropriate fasteners for securing the DRU to the selected mounting surface must be provided by the installer.

The DC power cable and optical fibers should be routed to the DRU front panel for connection. The antenna coaxial cable should be routed to the DRU rear panel for connection. A minimum of 3 inches (76 mm) of clearance space should be provided on all sides of the DRU (except the bottom) to ensure there is adequate air circulation for cooling. In addition, at least one surface of the DRU installation area must be open to the interior of the building. If a portable/flexible antenna will be installed, a minimum of 9 inches (229 mm) clearance should be allowed along the surface with the antenna. Refer to Figure 4 for the DRU dimensions.

3.3 Powering Requirements

3.3.1 DHU and DEU Powering

The DHU and DEU are powered by 120–240 Vac (50–60 Hz) which is supplied through a standard three-conductor AC power cord. The 120 Vac power cord is provided with the unit and is 98 inches (2.5 m) long. Both the DHU and the DEU have a current rating of **2.0 Amps at 120 Vac** input. Each unit should be located so that an AC outlet is within the reach of the power cord.

If back-up powering is required, it is recommended that the building Uninterruptible Power Supply (UPS) system be used to provide back-up power to the DHU and DEU in the event of an AC power outage. This will also power all the DRU's that are powered by the DHU or DEU.

3.3.2 DRU Powering

The DRU is powered by 48 Vdc power which is input to the DRU through the front panel RJ-45 connector. Power to the DRU may be provided by the DHU, DEU, or by a 120 Vac to 48 Vdc power converter (available separately as an accessory item) plugged into a properly grounded 120 Vac outlet. The DRU has a current rating of **400 mA at 48 Vdc** input.

If the DRU will be powered by the DHU or DEU, the power cable must be fabricated on-site by the installer. Category 3 or 5 twisted pair cable should be used for the power supply cable. The maximum recommended length of the power cable is **500 meters**. The power cable must be routed between the DHU or DEU and the DRU. Both ends of the power cable must be terminated with a **male** RJ-45 connector. If the DRU will be located more than 500 meters from the DHU or DRU, it must be locally powered by a 48 Vdc power converter.

The DRU may be powered locally by the ac/dc converter, shown in Figure 10, which is available as an accessory item. The converter is a UL Listed stand alone Limited Power Supply (LPS) unit with a rated output of **48 Vdc at 1.2 Amps**. The converter is equipped with a 6-foot (1.8 m) DC power cable which is terminated with an RJ-45 male connector. The converter is powered by 120–240 Vac (50–60 Hz) power which is supplied through a standard three-conductor AC power cord. The 120 Vac power cord is 6 feet (1.8 m) long and is provided with the converter.

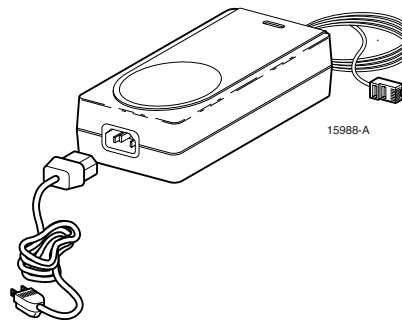

Figure 10. AC/DC Power Converter

3.4 Optical Options and Requirements

Each DHU and its associated DEU's and DRU's are connected over a pair of optical fibers. One fiber transports the forward path optical signal and the other fiber transports the reverse path optical signal. Either 62.5 or 50 micron core multi-mode optical fiber; or 9 micron core single-mode optical fiber may be used for the optical transport connection. With 62.5 micron core fiber, the optical path may be up to 500 meters in length. With 50 micron core fiber, the optical path may be up to 750 meters in length. With 9 micron core cable, the optical path may be up to 10 kilometers in length. Single- and multi-mode fibers may be used in the same system. A diagram of the optical connections is shown in Figure 11.

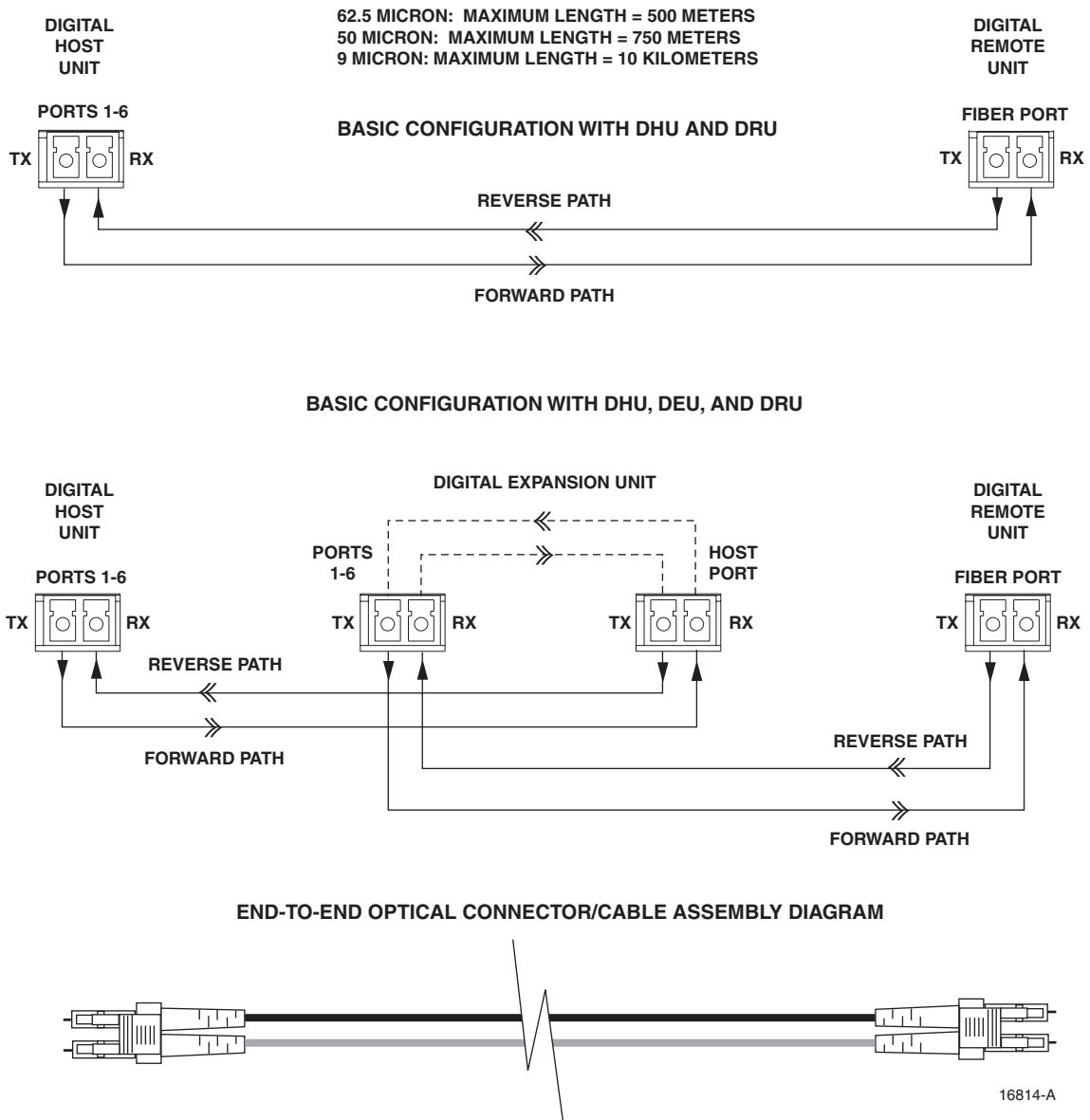

Figure 11. Digivance ICS Optical Connections

Whenever possible, use conduit or a guideway such as the FiberGuide system to route the optical fibers between the DHU, the DEU's, and the DRU's. Avoid routing optical fibers through ladder type cable racks or troughs that do not provide sufficient support to limit bending or prevent accidental damage. Tie-wrapping is not recommended as a means of securing fiber optic cables. Provide sufficient slack at each unit for connecting each fiber to the required port. Fibers may be pre-terminated or terminated on-site using field-installable LC type connectors.

3.5 Coaxial Cable Requirements

The DHU interfaces either locally (see Figure 8) or remotely (see Figure 9) with the BTS through coaxial cable connections. In a local interface with the BTS, coaxial cables are

required to link the DHU with the interface device and the interface device with the BTS. In a remote interface, coaxial cables are required to link the DHU with the interface device and the interface device with the donor antenna. The DHU is equipped with N-type female connectors for connecting the forward and reverse path coaxial cables. High performance, flexible, low loss 50-ohm coaxial communications cable (RG 400 or equivalent) should be used for all coaxial connections.

3.6 System Expansion Planning

The DEU enables 6-way expansion of any optical port. This makes it possible to add more DRU's without having to install additional DHU's. Each DHU is equipped with six optical ports. If more than six DRU's are required by the application, a DEU may be connected to one of the optical ports at the DHU which expands that port to six ports. If still more optical ports are required, then a second DEU may be connected to the DHU or a second DEU may be connected to the first DEU. The ability to cascade DEU's in parallel or in series provides unlimited flexibility. It is physically possible to connect an unlimited number DRU's to the DHU through the installation of DEU's.

The total number of DRU's that can be served is limited by the cumulative noise effect caused by antenna combining. This number cannot be determined until the radius distance of coverage required at the DRU antenna is determined and the path loss attributed to the structure are known. The system design requires that the carrier to noise differential be greater than the customer's desired signal to noise ratio.

If it is likely that the system will be expanded in the future, locate the DHU in such a way that it can be used as a hub for an expanded system. It should be noted that a DEU can be used as an optical regenerator. A DRU may sometimes need to be located at a point that is beyond the distance limitation imposed by the optical fiber. The solution is to install a DEU at the maximum optical fiber length from the DHU. This provides an additional 500 m, 750 m, or 10 km (depending on the fiber type) of optical fiber length beyond the DEU for connecting the DRU.

3.7 DRU Antenna Options

Various antennas, shown in Figure 12, are available from ADC for use with the DRU. All antennas include a 6-foot (1.8 m) long 50-ohm coaxial cable (equipped with SMA male connector) for connection to the DRU. The DRU is equipped with an SMA female connector for connecting the antenna cable.

The DRU antennas are designed for unobtrusive mounting within an office environment. Each type of antenna provides a specific coverage pattern in order to accommodate the shape of the area where coverage is required. The ceiling-mount omni directional antenna is designed to mount in the center of the coverage area. The directional panel antennas are designed to mount vertically on one side of the coverage area or in the corner of the coverage area. The ceiling mount hallway antenna is designed to mount in the center of long corridors. Antennas other than those offered by ADC may also be used if required.

- Note:** To comply with Maximum Permissible Exposure (MPE) requirements, the maximum composite output from the antenna cannot exceed 1.5 Watts ERP and the antenna must be permanently installed in a fixed location that provides at least **20 centimeters** (8 inches) of separation from all persons per FCC 47 CFR part 2.1091.

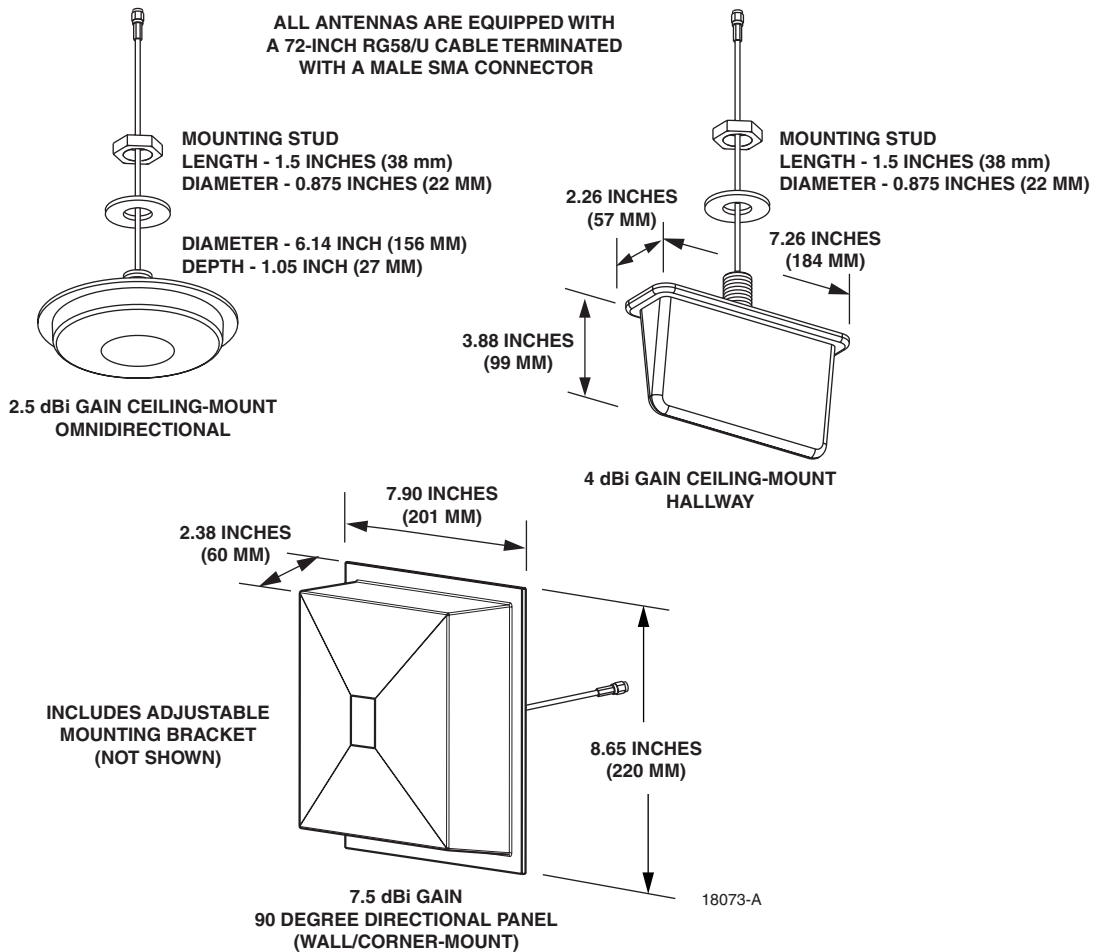

Figure 12. SMR⁺ DRU Antenna Options

3.8 External Alarm System Reporting Requirements

The DHU provides normally open (NO) and normally closed (NC) form C dry alarm relay contacts for reporting **minor** and **major** alarms to an external alarm system. A minor alarm is defined as a high temperature condition. A major alarm is defined as any fault condition except high temperature. Connections to the alarm contacts are provided through a screw-type terminal strip. Category 3 or 5 cable should be used for the alarm wires. If an external alarm system is not in use, no alarm connections are required.

3.9 Maintenance Requirements

The Digivance ICS requires no regular maintenance to insure continuous and satisfactory operation. Maintenance, as it applies to the Digivance ICS, primarily involves diagnosing and correcting service problems as they occur. Faults and failures arising from within the Digivance ICS will generate an external alarm response which includes lighting an LED indicator(s) and closing or opening a set of alarm contacts. When an alarm is reported, it will be necessary to isolate the source of the problem by observing the LED indicators on each unit and then performing various tests to isolate the problem. Once the source of the fault is isolated, the appropriate action can be taken to correct the problem. The only unit components that can be replaced are the cooling fans which are mounted in the DHU and the DEU and the modular optical transceivers. The failure of any other component within a unit will require replacement of the unit. Basic trouble-shooting procedures are provided in Section 6 of this manual.

3.10 System Design Recommendations

Follow a systematic process when designing an in-building coverage solution. The following sub sections outline the four phases of the in-building coverage solution design process. System design and planning services are available from ADC if required. Refer to Section 7 of this manual for additional information.

3.10.1 Phase One – Initial Evaluation

Qualify the Installation: Confirm that there are no extenuating circumstances that would prevent a successful installation such as: extreme cellular system issues (blocking, severe interference, site problems, etc.), building issues, power issues, or safety issues (site should not present any hazards or conditions that would make operation of the equipment unsafe).

Analyze the RF Situation: Determine how the system RF link to the outside world will be provided. Will it be a direct feed from a BTS (microcell) or an over-the-air connection via a donor antenna? If it is a donor antenna, is the customer within the coverage footprint of a serving cell or better? The coverage can be determined during the preliminary walkthrough by checking the downlink Received Signal Strength Indication (RSSI) outside the building with a unity gain sampling antenna. Sometimes a rooftop reading is needed to obtain a sufficient signal level. Note that it is an **FCC violation** to expand the normal coverage footprint of a cellular site with an in-building product. In addition, consider the impact the system will have on traffic, especially the busy hour. Confirm with the service provider that the expected increase in the volume of calls will be addressed (if needed), possibly with additional equipment such as additional channels or a microcell.

Determine the Amount of Building Attenuation: If a donor antenna will provide the RF link to the BTS, determine if there is enough signal isolation between the donor antenna and the in-building system to avoid a feedback loop and signal degradation. This step can often be accomplished during the preliminary walkthrough.

Discuss Installation with Building Management and Engineering: Discuss all *initially anticipated* Digivance ICS coverage areas (including any obviously desirable cable routings, equipment installations, power and mechanical requirements) with the authorized client and

building personnel for an initial approval/confirmation. This gives a good estimate of the extent of the system work needed. Occasionally, some of the system design work can be accomplished at this point.

3.10.2 Phase Two – System Design

Determine forward and reverse path loss and then design for unity gain on the uplink and maximum power out of the DRU on the downlink: The overall purpose of the Digivance ICS is to transparently overcome attenuation losses, not to provide additional gain beyond what is required to bring the signal to unity gain. Complete the following steps to make this determination:

1. Determine the in-building reverse path (uplink) losses at typical operating frequencies and distances from the subscriber handset (terminal) to the DRU. This information will be used to determine the optimal uplink signal level to the outside world.
2. Determine the typical composite cell site Effective Radiated Power (ERP) into the system. Calculate the interface adjustment required to feed the required downlink signal level to the DHU in order to drive the DRU output signal at the desired level.

Determine the location of the DHU and its RF and AC power sources: Complete the following steps to make this determination:

1. Determine where and how the DHU will be mounted.
2. Determine the location of the DHU AC power source.
3. Determine the RF source (local interface with BTS or remote interface with BTS through donor antenna) for the DHU.
4. If local interface connection with the BTS is required, determine the distance to the DHU.
5. If a remote connection with the BTS is required, determine what type of antenna is needed and where it can be mounted.
6. Determine the attenuation or amplification requirements for the DHU to BTS interface.

Discuss the design of the Digivance ICS installation with building management and engineering: Explain the proposed system design with building management and engineering personnel and obtain final design approval prior to installation.

3.10.3 Phase Three – Installation

Use industry standard practices for cabling, installation, and powering to complete the following:

1. Install the DHU as described in Section 3 of this manual and adjust the RF interface levels based on the system design specifications.
2. Install a DRU as described in the Digital Remote Unit Installation Instructions (ADCP - 75-112). If a donor antenna is used, install the DHU close to the donor antenna.

3. Conduct an initial performance evaluation and complete the following:
 - a) Confirm proper isolation, signal quality, and power levels.
 - b) Make test calls from DRU service area and evaluate call quality (confirm with service provider if desired).
 - c) Address performance issues as needed.
4. Install the remaining DRU's and also any DEU's as described in the Digital Expansion Unit Installation Instructions (ADCP-75-111). Test call quality and range of each DRU as needed.
5. Check powering and alarm functions of entire system per Digivance ICS specifications.

3.10.4 Phase Four - Performance Evaluation

Complete the following to evaluate the performance of the Digivance ICS:

1. Evaluate the forward path (downlink) and reverse path (uplink) RF signal levels and quality.
2. Make continuous calls from DRU to DRU, checking all service areas, seams, and coverage boundaries for call quality (both DL and UL). Address all quality issues as needed.
3. Place calls both leaving and entering the building(s), in parking lots, etc. Address all quality issues as needed.
4. Contact client/service provider to inform them when the Digivance ICS is operational.

4 DIGITAL HOST UNIT INSTALLATION PROCEDURE

This section provides the installation procedures for the DHU. Installation of the DEU(s) and DRU(s) may proceed separately from the installation of the DHU. The installation procedures for the DEU are provided in the Digital Expansion Unit Installation Instructions (ADCP -75-111) which are shipped with the DEU. The installation procedures for the DRU, the DRU antennas, and the ac/dc converter (optional DRU accessory) are provided in the Digital Remote Unit Installation Instructions (ADCP-75-112) which are shipped with the DRU. When all units of the Digivance ICS have been installed, refer to Section 5 of this manual for the system power up and test procedures.

4.1 System Plan Review and Pre-Installation Cable Routing

Before beginning the installation, review the system plan with the system engineer. Make sure each equipment installation site is identified and located and all cable runs are mapped out. The coaxial, DC power, and fiber optic cables may be routed between the various equipment locations before the equipment is installed. Whenever possible, route fiber optic cables through conduit or a guideway such as the FiberGuide system. Avoid routing fibers through ladder type cable racks or troughs that do not provide sufficient support to limit bending or prevent accidental damage. Tie-wrapping is not recommended as a means of securing fiber optic cables. Make sure to leave sufficient slack at each equipment location for connectorizing and cable management. The procedures for terminating the cables and for connecting the cables to the DHU are provided in the sections that follow.

4.2 Tools and Materials

The following **tools** are required in order to complete the procedures in this section:

- Box cutter
- Pencil or scribe
- Medium and small size flat-bladed screwdrivers
- TORX screwdriver (T20 bit)
- Pliers
- Wire cutters
- Wire stripper
- Tool kit for attaching RJ-45 male connectors to category 3 or 5 cable
- Tool kit for attaching N-type male connectors to coaxial cable
- Tool kit for attaching LC connectors to multimode fiber optic cable
- Drill and assorted drill bits (wall-mount installations only)
- Multimeter
- Optical power meter
- Laser light source
- ESD wrist strap

The following **materials** are required in order to complete the procedures in this section:

- Wall-mount fasteners (wall-mount applications only)
- #22 AWG (0.40 mm) category 3 or 5 cable (for power cable and external alarm connections)
- RJ-45 male connectors (for power cable)
- #18 AWG (1.00 mm) insulated stranded copper wire (for chassis grounding wire)
- Ring terminal for #18 wire (for chassis ground wire connection)
- 50 or 62.5 micron core multi-mode or 9 micron core single-mode fiber optic cable
- LC-type field installable connectors
- High performance, flexible, low loss 50-ohm coaxial cable
- N-type male connectors
- Wire ties

4.3 Unpacking and Inspection

This subsection provides instructions for opening the shipping boxes, verifying that all parts have been received, and verifying that no shipping damage has occurred. Use the following procedure to unpack and inspect the DHU:

1. Open the shipping carton and carefully unpack the DHU from the protective packing material.
2. Check the DHU for broken or missing parts. If there are any damages, contact ADC (see Section 6 at the end of this manual) for an RMA (Return Material Authorization) and to reorder if replacement is required.

4.4 Mounting Procedure

The DHU may be either rack-mounted or wall-mounted. Of the procedures that follow, use whichever procedure is appropriate for the installation:

- ▶ **Note: To insure that all optical connectors and transceivers remain dust-free during installation, leave all dust caps and dust protectors in place until directed to remove them for connection.**

4.4.1 Rack Mount Installation

The DHU may be mounted in either a 19-inch or 23-inch EIA or WECO equipment rack. Both US standard and metric machine screws are included for rack mounting the DHU. When loading the DHU in a rack, make sure the mechanical loading of the rack is even to avoid a hazardous condition such as a severely unbalanced rack. The rack should safely support the combined weight of all the equipment it holds and be securely anchored. In addition, the maximum recommended ambient temperature for the DHU is 50° C (122° F). Allow sufficient air circulation or space between units when the DHU is installed in a multi-unit rack assembly because the operating ambient temperature of the rack environment might be greater than room ambient.



Warning: Wet conditions increase the potential for receiving an electrical shock when installing or using electrically-powered equipment. To prevent electrical shock, never install or use electrical equipment in a wet location or during a lightning storm.

Use the following procedure to install the DHU in the equipment rack:

1. The DHU is shipped with the mounting brackets installed for 19-inch rack installations. If mounting the DHU in a 19-inch rack, proceed to step 4. If mounting the DHU in a 23-inch rack, proceed to step 2.
2. Remove both mounting brackets from the DHU (requires TORX screwdriver with T20 bit)
3. Reinstall both mounting brackets so the long side of the bracket is flush with the DHU front panel as shown in Figure 13. Use the screws removed in step 2 to re-attach the brackets to the DHU enclosure.
4. Position the DHU in the designated mounting space in the rack (per system design) as shown in Figure 14.

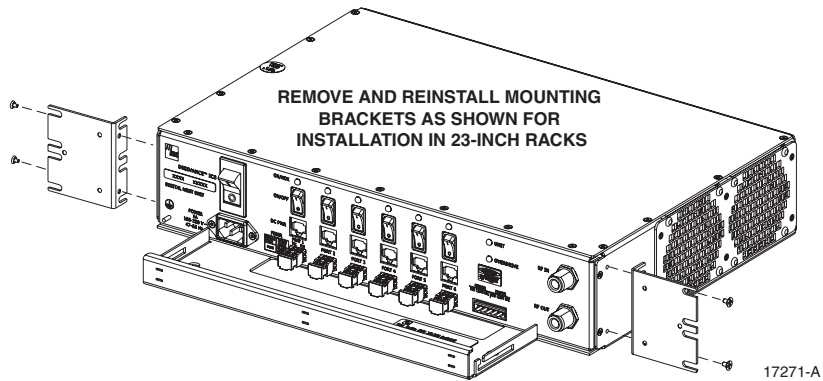

Figure 13. Installing the Mounting Brackets for 23-Inch Rack Installations

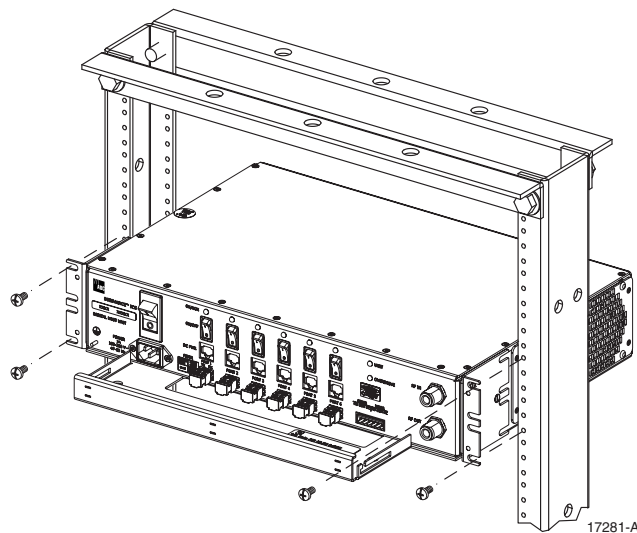

Figure 14. DHU Rack Mount Installation

5. Secure the mounting brackets to the rack using the four machine screws provided (use #12-24 screws or M6 x 10 screws, whichever is appropriate).
- **Note:** Provide a minimum of 3 inches (76 mm) of clearance space on both the left and right sides of the DHU for air intake and exhaust.

4.4.2 Wall-Mount Installation

The DHU may be mounted from any flat vertical surface. It is recommended that a backer board such as 3/4-inch plywood be applied over the mounting surface to provide a secure base for attaching the DHU. Two mounting holes are provided in the cable management tray for securing the DHU to the mounting surface. The fasteners must be provided by the installer. Use the following procedure to wall-mount the DHU:



Warning: *Wet conditions increase the potential for receiving an electrical shock when installing or using electrically-powered equipment. To prevent electrical shock, never install or use electrical equipment in a wet location or during a lightning storm.*

1. Obtain the appropriate fasteners (lag bolts, screw anchors, etc.) for securing the DHU to the mounting surface.
 2. Position the DHU on the mounting surface in the specified location (per the system design) with the front panel facing up as shown in Figure 15.
- **Note:** Provide a minimum of 3 inches (76 mm) of clearance space on both the left and right sides of the DHU for air intake and exhaust.

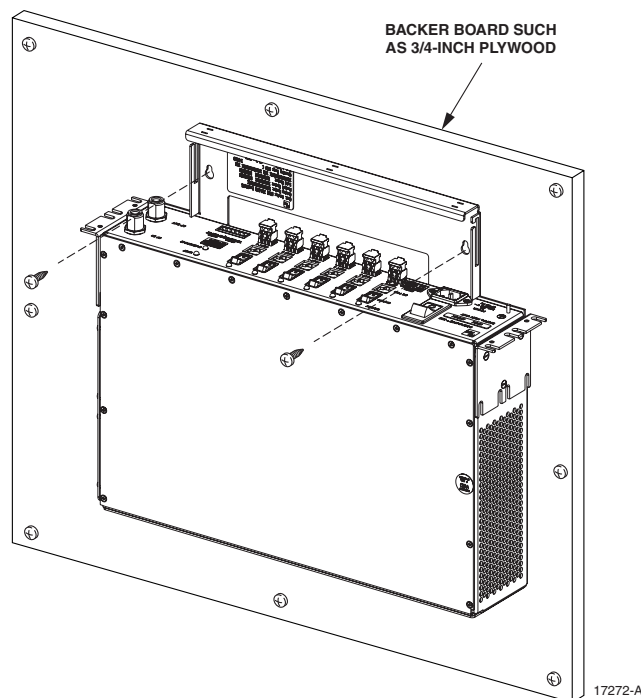

Figure 15. DHU Wall-Mount Installation

3. Using the DHU as a template, mark the location of the mounting holes on the mounting surface.
- ▶ **Note:** The mounting holes in the DHU cable management tray are spaced 11-21/32 inches (296 mm) center to center.
4. Set the DHU aside and then drill appropriately sized holes in the mounting surface for the fasteners.
5. Partially install the fasteners in the drilled holes. Leave the head of each fastener protruding about 1/4 inch (6 mm) from the mounting surface.
6. Hang the DHU from the fasteners and then securely tighten each fastener.

4.5 Chassis Ground Connections

A stud is provided on the front side of the chassis for connecting a grounding wire to the chassis. Use the following procedure to connect the grounding wire to the chassis and to route the grounding wire to an approved earth ground source:

1. Obtain a length of #18 AWG (1.00 mm) insulated **stranded** copper wire for use as a chassis grounding wire.
2. Terminate one end of the wire with a ring terminal.
3. Locate the chassis ground stud at the front of the DHU as shown in Figure 16.

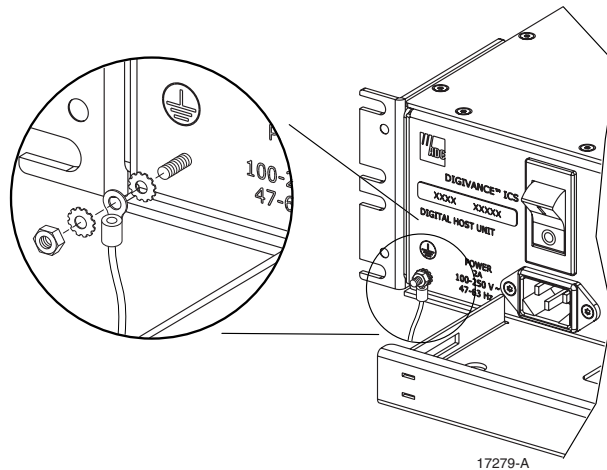

Figure 16. Chassis Ground Stud

4. Secure the ring end of the wire to the chassis ground stud (see Figure 16) using the nut and two star washers provided.
5. Route the free end of the chassis grounding wire to an approved (per local code or practice) earth ground source.
6. Cut the chassis grounding wire to length and connect it to the approved ground source as required by local code or practice.
- ▶ **Note:** Be sure to maintain reliable grounding for rack and wall mounted equipment. Pay particular attention to ground source connections.

4.6 Coaxial Cable Connections

The RF interface between DHU and the BTS is supported through a pair of type N female connectors mounted on the DHU front panel. One connector provides the coaxial cable connection for the forward path (downlink) signal. The other connector provides the coaxial cable connection for the reverse path (uplink) signal. Coaxial cables link the DHU to the BTS through an interface device. Use the following procedure to install the forward and reverse path coaxial cables and connect them to the DHU:

1. Obtain the required lengths of high performance, flexible, low loss 50-ohm coaxial communications cable (RG 400 or equivalent) for all coaxial connections.
2. Route the forward path and reverse path coaxial cables (if not already routed) between the DHU and the specified BTS interface device (per system design) and cut to the required length. Allow sufficient slack for dressing and organizing cables at the DHU.
3. Terminate each cable with a type N male connector following the connector supplier's recommendations.
4. Connect the forward path cable to the **RF IN** connector on the DHU front panel as shown in Figure 17.
5. Connect the reverse path cable to the **RF OUT** connector on the DHU front panel as shown in Figure 17.

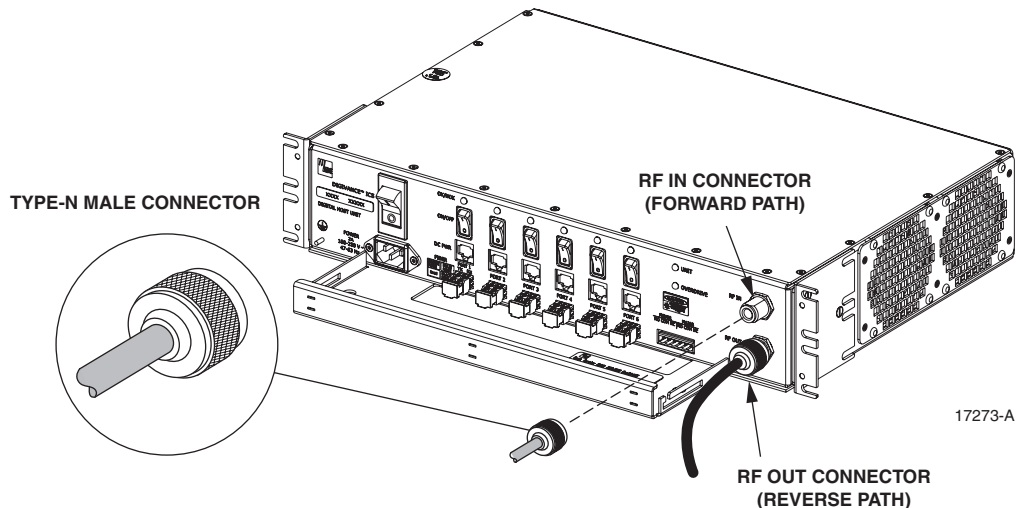

Figure 17. Forward and Reverse Path Coaxial Cable Connections

6. Dress and secure cables at the DHU per standard industry practice.
7. Connect the forward and reverse path cables to the local (microcell) or remote (donor antenna) interface device as specified in the instructions provided with that unit.
8. Complete all remaining coaxial cable connections between the local interface device and the BTS or between the remote interface device and the donor antenna as specified in the instructions provided with the equipment.

4.7 Modular Optical Transceiver Installation

The modular optical transceivers are available separately and may or may not be installed in the DHU depending on the configuration ordered. If the optical transceivers are factory installed in the DHU, skip this section and proceed to Section 4.8. If the optical transceivers are not factory installed, use the following procedure to install each transceiver:

1. Slip on an Electro-Static Discharge (ESD) wrist strap and connect the ground wire to an earth ground source such as the grounding stud on the DHU front panel. Wear the ESD wrist strap while completing the optical transceiver installation procedure.



Warning: *Electronic components can be damaged by static electrical discharge. To prevent ESD damage, always wear an ESD wrist strap when handling electronic components.*

2. Locate the appropriate transceiver socket on the front of the DHU as shown in Figure 18.

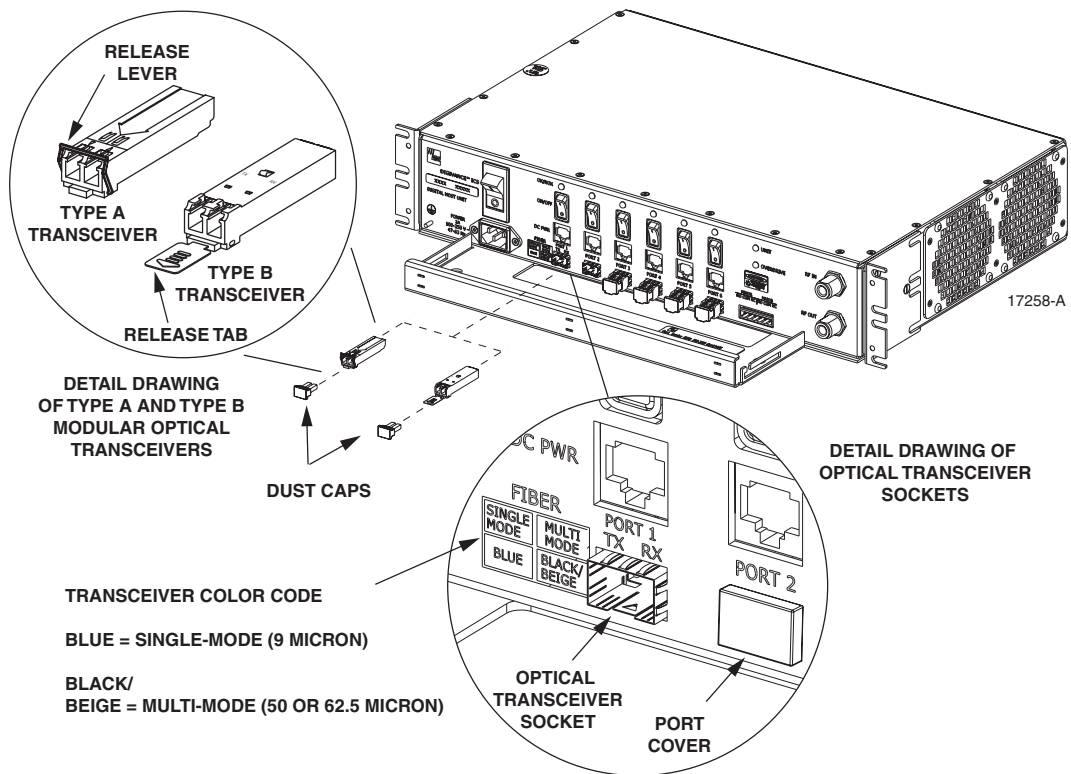

Figure 18. Optical Transceiver Installation

3. Select the optical transceiver that corresponds to the type of fiber (single- or multi-mode) required for the installation. The color of the transceiver (see transceiver color code in Figure 18) corresponds to the fiber type.
4. Remove the transceiver from the anti-static packaging and orient for installation (see Figure 18.).

► **Note:** Two types of optical transceivers, type A and type B, are available. Both types provide the same functionality. On the type A optical transceiver, the release lever (see Figure 18) must be closed for installation.