

2. TEST STATEMENT

2.1 TEST STATEMENT

TO whom it may concern,

This letter is to explain the test condition of this project.
The EUT be tested as the following status.

CPU: PENTIUM II - 333 MHz	CPU Clock Signal: 66 MHz
CPU: PENTIUM II - 400 MHz	CPU Clock Signal: 100 MHz

The data was shown in this report reflects the worst-case data
for each condition as listed above.

Please disregard any other conditions that shown in this user
manual.

2. TEST STATEMENT

2.2 DEPARTURE FROM DOCUMENT POLICIES, PROCEDURE OR SPECIFICATIONS

DID HAVE
ANY DEPARTURE FROM DOCUMENT POLICIES
& PROCEDURES OR FROM SPECIFICATIONS.

YES _____ , NO N/A .

IF YES, THE DESCRIPTION AS BELOW.

2.3 TEST STATEMENT

1. THE CERTIFICATE OR REPORT SHALL NOT BE REPRODUCED EXCEPT IN FULL, WITHOUT THE WRITTEN APPROVAL OF THE LABORATORY.
2. THE REPORT MUST NOT BE USED BY THE CLIENT TO CLAIM PRODUCT ENDORSEMENT BY NVLAP OR ANY AGENCY OF THE U.S. GOVERNMENT.

3. EUT MODIFICATIONS

THE FOLLOWING ACCESSORIES WERE ADDED TO THE EUT DURING TESTING:

- 1) .GROUND OF COM1 AND COM2 ADDED SPRING FIGURE TO CHASSIS GROUND.
- 2) .C100,C101,C102,C103,C104,C105,C106,C107,C108,C109,C110,C111,C112,C113,C114 AND C115 ADDED 690pF TO GROUND.
- 3) .C92,C93,C94,C95,C96,C97,C98,C99,C86,C87,C88,C89,C90 AND C91 ADDED 22pF TO GROUND.
- 4) .EACH SKEW OF I/O PORT ADDED A METAL WASHER IMPROVE CHASSIS GROUND.

4. MODIFICATION LETTER

THIS SECTION CONTAINS THE FOLLOWING DOCUMENTS:

A. LETTER OF MODIFICATIONS

N/A



DTK Computer Inc.

Atlanta ■ Chicago ■ Hong Kong ■ Houston ■ London ■ Los Angeles ■ Melbourne ■ Miami ■ Munich ■ New York ■ Paris ■ Poland ■ Taipei ■ Vietnam

Federal Communications Commission
Authorization and Evaluation Division
7435 Oakland Mills Road
Columbia, MD 21046

To whom it may concern :

This is to serve as proper notice that our company agrees to make all modifications to FCC ID : F825K4APRI80 as listed in section 3.0 of modification to submitted by Spectrum Research and Testing Laboratory, Inc.

Respectfully,

Fddy L...
(Name, Surname)

Project Leader
(Position/Title)

Effective Dates :

From *Dec. 29, 1998* to *Dec. 31, 2000*

DATE : *Dec. 29, 1998*

5. CONDUCTED POWER LINE TEST

5.1 TEST EQUIPMENT

THE FOLLOWING TEST EQUIPMENT WAS USED DURING THE CONDUCTED POWER LINE TEST :

EQUIPMENT/ FACILITIES	SPECIFICAT -IONS	MANUFACTURER	MODEL#/ SERIAL#	DATE OF CAL. & CAL.CENTER	DUE DATE
SPECTRUM ANALZER	9 KHz TO 1 GHz	HP	8590L/ 3624A01317	OCT, 1997 ETC	1Y
EMI TEST RECEIVER	9 KHz TO 30 MHz	ROHDE & SCHWARZ	ESHS30/ 893517/013	OCT, 1997 ETC	1Y
LISN	50 uH, 50 ohm	SOLAR ELECTRONICS	9252-50- R24-BNC/ 951315	AUGUST, 1997 ETC	1Y
LISN	50 uH, 50 ohm	SOLAR ELECTRONICS	9252-50- R24-BNC/ 951318	AUGUST, 1997 ETC	1Y
SIGNAL GENERATOR	9 KHz TO 1080 MHz	ROHDE & SCHWARZ	SMY01/ 841104/019	MAY, 1997 ETC	1Y
POWER CONVERTER	0 TO 300 VAC 47 - 500 Hz	AFC	AFC-1KW/ 850510	APRIL, 1997 SRT	1Y

5.2 CONFIGURATION OF THE EUT

THE EUT WAS CONFIGURED ACCORDING TO ANSI C63.4 - 1992.
 ALL INTERFACE PORTS WERE CONNECTED TO THE APPROPRIATE
 PERIPHERALS. ALL PERIPHERALS AND CABLES ARE LISTED
 BELOW.

-EUT

DEVICE	MANUFACTURER	MODEL #	FCCID
PC SYSTEM	DTK COMPUTER INC.	APRI-80	F825K4APRI80

-REMARK

-INTERNAL DEVICES

<u>DEVICE</u>	<u>MANUFACTURER</u>	<u>MODEL #</u>	<u>FCCID</u>
MAIN BOARD	DTK	PRM-0080I	DoC
POWER SUPPLY	DTK	PTP-3038	DoC
HDD	SEAGATE	ST351A/X	N/A
FDD (3.5")	PANASONIC	JU-257A606P	N/A
AGP CARD	ASUS	AGP-V3000	DoC

- PERIPHERALS

DEVICE	MANUFACTURER	MODEL# / SERIAL#	FCC ID	CABLE
MONITOR	PHILIPS	14B1320W	A3KM064	POWER-UNS DATA-S
PRINTER	HP	2225C+	DSI6XU2225	POWER-UNS DATA-S
MODEM	SMARTEAM	103/212A	EF56A5103/212A	POWER-UNS DATA-S
MODEM	SMARTEAM	103/212A	EF56A5103/212A	POWER-UNS DATA-S
KEYBOARD	HP	SK-2502	GYUR41SK	DATA-UNS
MOUSE	HP	M-S34	DZL210582	DATA-UNS
USB MOUSE	ABIT	97M32U	M5497M32U	DATA-S
USB MOUSE	ABIT	97M32U	M5497M32U	DATA-S

- REMARK

- (1). CABLE - UNS : UNSHIELDED CABLE
S : SHIELDED CABLE
- (2). CABLES - ALL 1m OR GREATER IN LENGTH-
BUNDLED ACCORDING TO ANSI C63.4 - 1992.

5.3 EUT OPERATING CONDITION

OPERATING CONDITION IS ACCORDING TO ANSI C63.4 - 1992.

1. EUT POWER ON.
2. "H" PATTERN SENT TO THE FOLLOWING PERIPHERALS:
 - PRINTER
 - MONITOR
 - MODEM * 2
3. CPU : PENTIUM II - 333MHZ
CLOCK CHIP : 66MHZ
CPU : PENTIUM II - 400MHZ
CLOCK CHIP : 100MHZ

5.4 TEST PROCEDURE

THE EUT WAS TESTED ACCORDING TO ANSI C63.4 - 1992. THE CONDUCTED TEST WAS PERFORMED IN AN ANECHOIC CHAMBER. THE FREQUENCY SPECTRUM FROM 0.45 MHz TO 30 MHz WAS INVESTIGATED. THE LISN USED WAS 50 ohm / 50 uHenry AS SPECIFIED BY SECTION 5.1 OF ANSI C63.4 - 1992. CABLES AND PERIPHERALS WERE MOVED TO FIND THE MAXIMUM EMISSION LEVELS FOR EACH FREQUENCY.

5.5 TEST SETUP

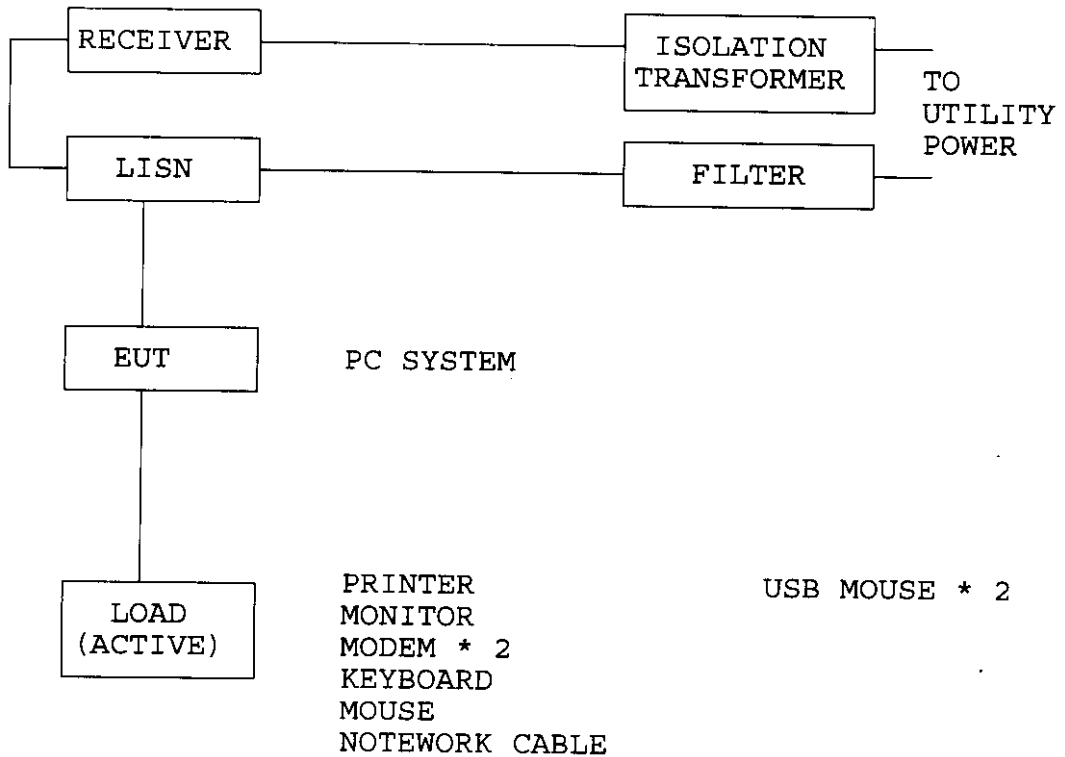
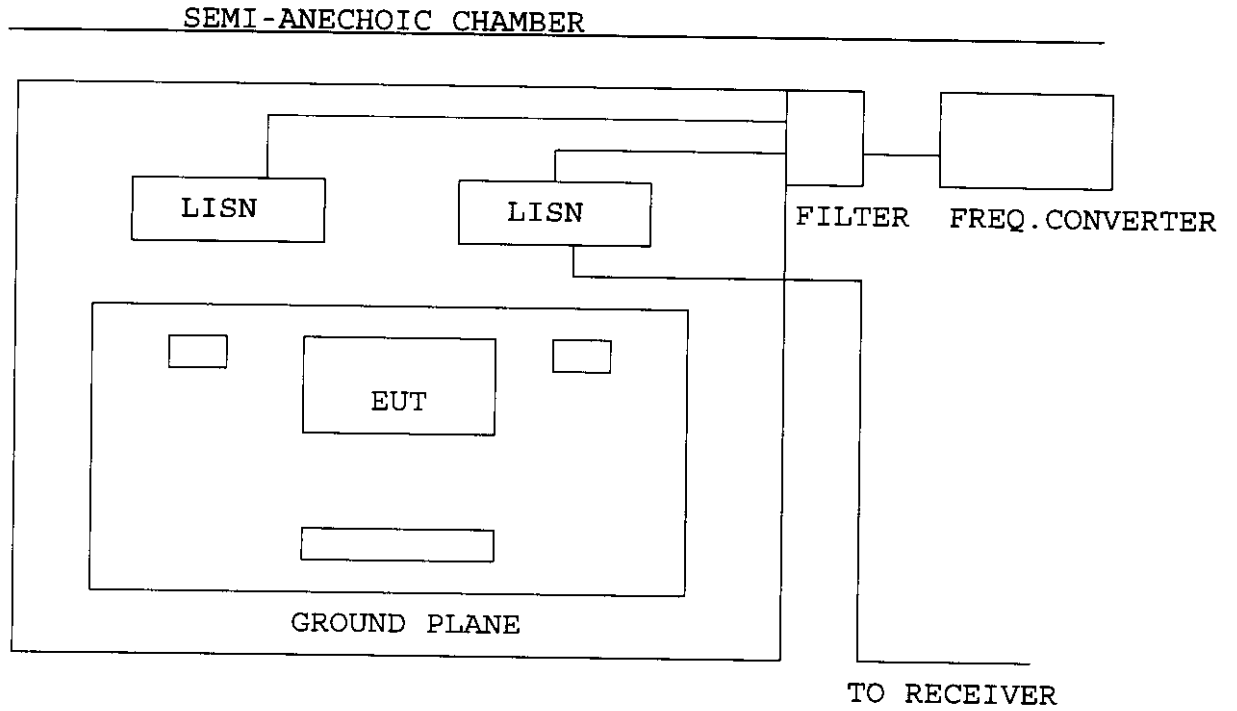

5.6 CONDUCTED POWER LINE EMISSION LIMIT

FREQUENCY RANGE (MHz)	CLASS A	CLASS B
0.045 - 1.705	1000 μ V	250 μ V
1.705 - 30	3000 μ V	250 μ V

NOTE : IN THE ABOVE TABLE, THE TIGHTER LIMIT APPLIES AT THE BAND EDGES.

5.7 CONDUCTED POWER LINE TEST RESULT

THE FREQUENCY SPECTRUM FROM 0.45 MHz TO 30 MHz WAS INVESTIGATED. ALL READINGS ARE QUASI-PEAK VALUES WITH A RESOLUTION BANDWIDTH OF 9 KHz.

TEMPERATURE : 28 C

HUMIDITY : 78 %RH

FREQUENCY(MHz)	LINE 1 (uv)	LINE 2 (uv)	LIMIT (uv)
0.64	25.12	25.70	250
1.05	5.560	6.380	250
5.60	17.18	*	250
8.62	*	14.96	250
13.6	45.19	*	250

- REMARKS :
- (1) .* = MEMENT DOES NOT APPLY FOR THIS FREQUENCY
 - (2) .UNCERTAINTY IN CONDUCTED EMISSION MEASURED IS <+/-2dB
 - (3) .CPU: PENTIUM II - 333MHz CLOCK CHIP: 66MHz
 - (4) .TEST CONFIGURATION PLEASE SEE 4.2
 - (5) .TEST EQUIPMENT PLEASE SEE 4.1
 - (6) .ANY DEPARTURE FROM SPECIFICATION : N/A

SIGNED BY TESTING ENGINEER :

Taylor auth

5.7 CONDUCTED POWER LINE TEST RESULT

THE FREQUENCY SPECTRUM FROM 0.45 MHz TO 30 MHz WAS INVESTIGATED. ALL READINGS ARE QUASI-PEAK VALUES WITH A RESOLUTION BANDWIDTH OF 9 KHz.

TEMPERATURE : 28 C

HUMIDITY : 78 %RH

FREQUENCY (MHz)	LINE 1 (uv)	LINE 2 (uv)	LIMIT (uv)
0.64	26.30	25.12	250
0.78	12.59	*	250
1.11	*	7.240	250
8.27	16.98	15.31	250
17.3	*	43.65	250

- REMARKS : (1) . * = MEMENT DOES NOT APPLY FOR THIS FREQUENCY
 (2) . UNCERTAINTY IN CONDUCTED EMISSION MEASURED IS <+/-2dB
 (3) . CPU: PENTIUM II - 400MHz CLOCK CHIP: 100MHz
 (4) . TEST CONFIGURATION PLEASE SEE 4.2
 (5) . TEST EQUIPMENT PLEASE SEE 4.1
 (6) . ANY DEPARTURE FROM SPECIFICATION : N/A

SIGNED BY TESTING ENGINEER :

Taylor auth

6. RADIATED EMISSION TEST

6.1 TEST EQUIPMENT

THE FOLLOWING TEST EQUIPMENT WAS USED DURING THE RADIATED EMISSION TEST :

EQUIPMENT / FACILITIES	SPECIFICAT - IONS	MANUFACTUR - ER	MODEL#/ SERIAL#	DATE OF CAL. & CAL. CENTER	DUE DATE
RECEIVER	20 MHz TO 1000 MHz	R & S	ESVS 30/ 841977/003	APRIL, 1998 ITRI	1Y
SPECTRUM ANALYZER	100 Hz TO 1500 MHz	HP	8568B/ 3019A05294	OCT, 1997 ETC	1Y
SPECTRUM ANALYZER	9 KHz TO 22 GHz	HP	8593E/ 3322A00670	APRIL, 1998 ITRI	1Y
SPECTRUM ANALYZER	100 Hz TO 1000 MHz	IFR	A-7550/ 2684/1248	JULY, 1998 ETC	1Y
SIGNAL GENERATOR	9 KHz TO 1080 MHz	ROHDE & SCHWARZ	SMY01/ 841104/019	APRIL, 1998 ITRI	1Y
DIPOLE ANTENNA	28 MHz TO 1000 MHz	EMCO	3121C/ 9003-535	DEC, 1997 SRT	1Y
DIPOLE ANTENNA	28 MHz TO 1000 MHz	EMCO	3121C/ 9611-1239	DEC, 1997 SRT	1Y
BI-LOG ANTENNA	26 MHz TO 2000 MHz	EMCO	3142/ 9509-1152	DEC, 1997 SRT	1Y
BI-LOG ANTENNA	26 MHz TO 1100 MHz	EMCO	3143/ 9509-1152	DEC, 1997 SRT	1Y
PRE-AMPLIFIER	0.1 MHz TO 1300 MHz	HP	8447D/ 2944A08402	APRIL, 1998 ITRI	1Y
PRE-AMPLIFIER	0.1 MHz TO 1300 MHz	HP	8447D/ 2944A06412	OCT, 1997 ETC	1Y
HORN ANTENNA	1 GHz TO 18 GHz	EMCO	3115/ 9012-3619	DEC, 1997 SRT	1Y

6.2 CONFIGURATION OF THE EUT

SAME AS SECTION 5.4 OF THIS REPORT.

6.3 EUT OPERATING CONDITION

SAME AS SECTION 5.3 OF THIS REPORT.

6.4 TEST PROCEDURE

THE EUT WAS TESTED ACCORDING TO ANSI C63.4 - 1992. THE RADIATED TEST WAS PERFORMED AT SRT LAB'S OPEN SITE. THIS SITE IS ON FILE WITH THE FCC LABORATORY DIVISION, REFERENCE 31040/SIT.

THE FREQUENCY SPECTRUM FROM 30 MHz TO 2 GHz WAS INVESTIGATED. MEASUREMENTS WERE MADE AT THREE METERS WITH AN ADJUSTABLE DIPOLE ANTENNA. PERIPHERALS, CABLES, EUT ORIENTATION, AND ANTENNA HEIGHT WERE VARIED TO FIND THE MAXIMUM EMISSION FOR EACH FREQUENCY.

THE FREQUENCY SPECTRUM FROM 30 MHz TO 2 GHz WAS INVESTIGATED. THE MEASUREMENTS UNDER 1 GHz WITH RESOLUTION BANDWIDTH OF 120 KHz ARE QUASI-PEAK READING MADE AT THREE METERS USING AN ADJUSTABLE DIPOLE ANTENNA. PERIPHERALS, CABLES, EUT ORIENTATION, AND ANTENNA HEIGHT WERE VARIED TO FIND THE MAXIMUM EMISSION FOR EACH FREQUENCY.

THE MEASUREMENTS ABOVE 1 GHz WITH A RESOLUTION BANDWIDTH OF 1 MHz ARE PEAK READING AT A DISTANCE OF THREE METERS WITH A HORN ANTENNA.

6.5 RADIATED TEST SETUP

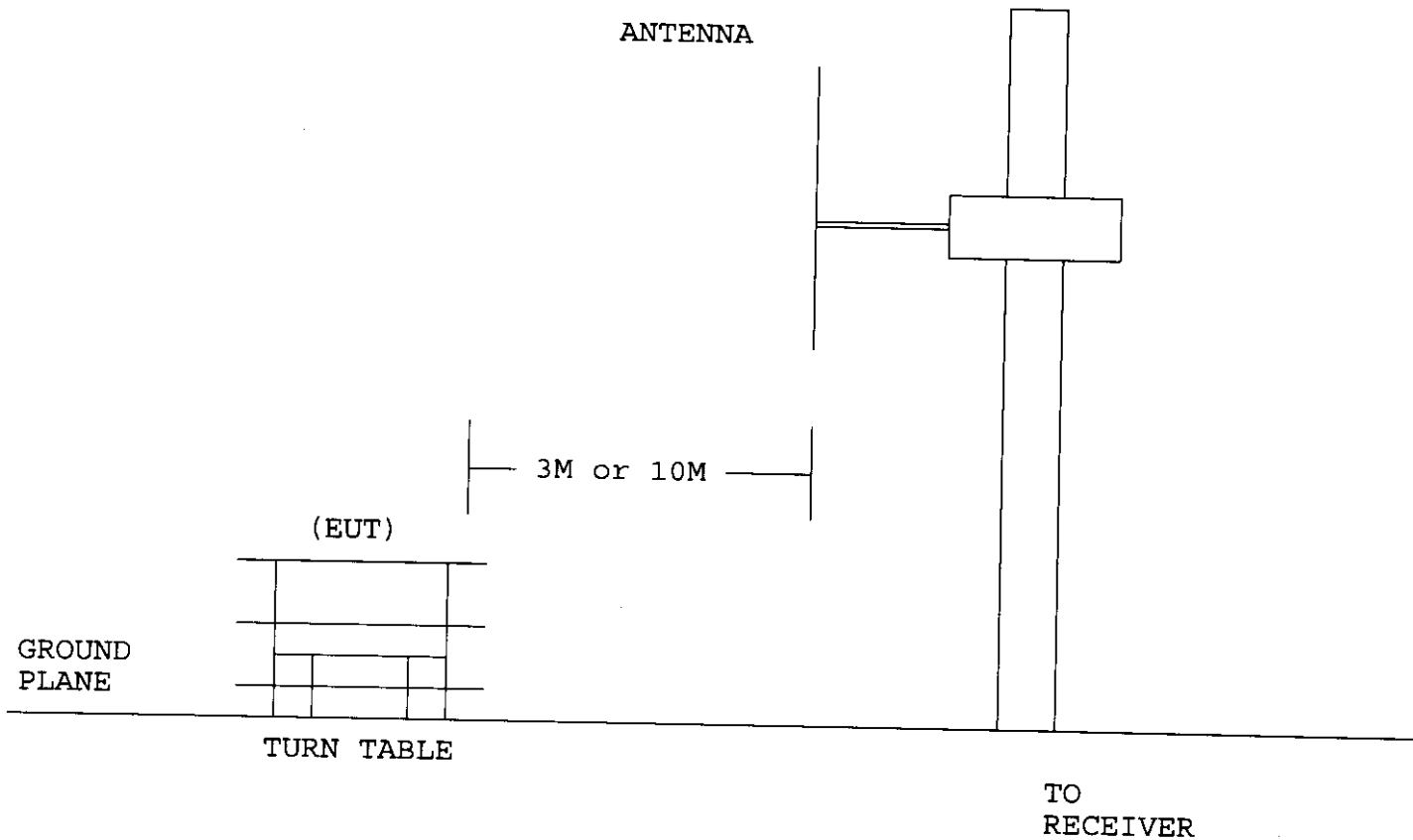

6.5 RADIATED TEST SETUP

ELECTRICAL AND ELECTRONIC EQUIPMENT IN THE RANGE OF 9 kHz TO 40 GHz

ANSI
C63.4-1992

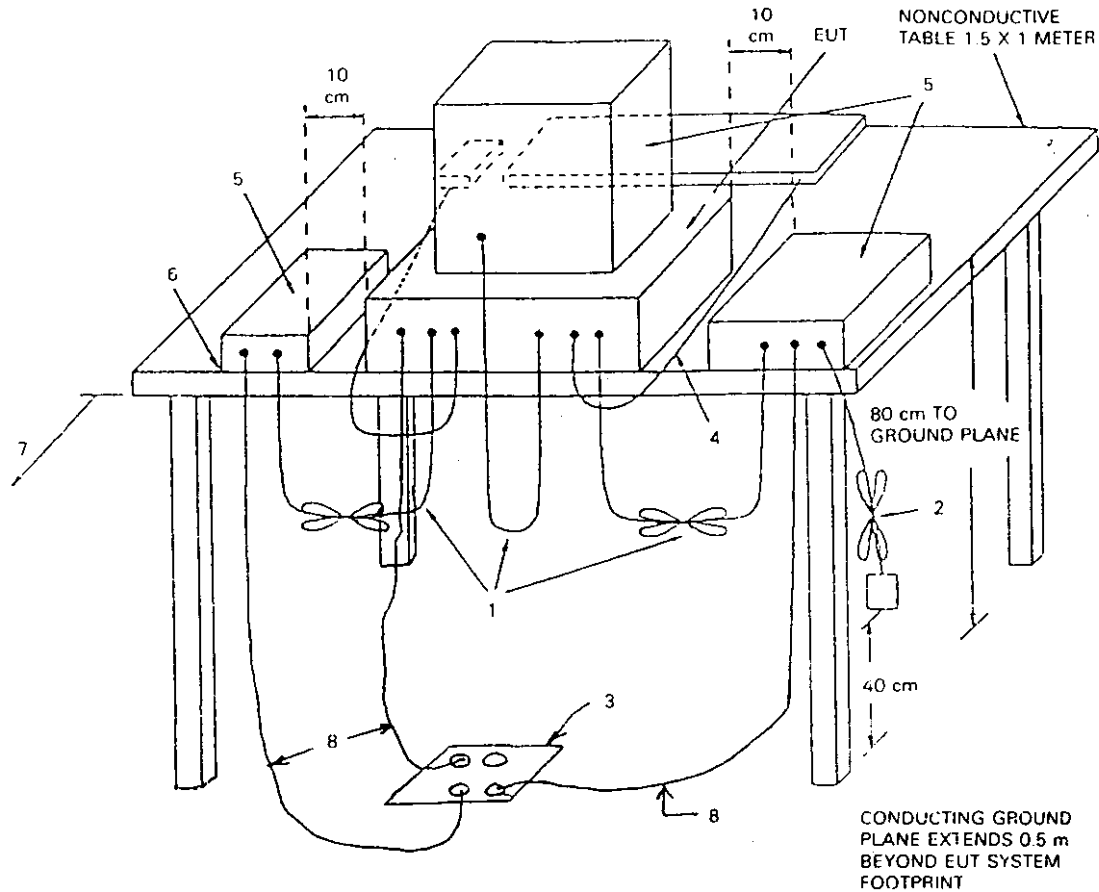

LEGEND:

1. Interconnecting cables that hang closer than 40 cm to the ground plane shall be folded back and forth forming a bundle 30 to 40 cm long, hanging approximately in the middle between ground plane and table.
2. I/O cables that are connected to a peripheral shall be bundled in center. The end of the cable may be terminated if required using correct terminating impedance. The total length shall not exceed 1 m.
3. If LISNs are kept in the test setup for radiated emissions, it is preferred that they be installed under the ground plane with the receptacle flush with the ground plane.
4. Cables of hand-operated devices, such as keyboards, mice, etc., have to be placed as close as possible to the controller.
5. Non-EUT components of EUT system being tested.
6. The rear of all components of the system under test shall be located flush with the rear of the table.
7. No vertical conducting wall used.
8. Power cords drape to the floor and are routed over to receptacle.

6.6 RADIATED EMISSION LIMIT

ALL EMISSION FROM A DIGITAL DEVICE, INCLUDING ANY NETWORK OF CONDUCTORS AND APPARATUS CONNECTED THERETO, SHALL NOT EXCEED THE LEVEL OF FIELD STRENGTH SPECIFIED BELOW :

CLASS B

FREQUENCY (MHz)	DISTANCE (m)	FIELD STRENGTH (uV/m)
30 - 88	3	100
88 - 216	3	150
216 - 960	3	200
ABOVE 960	3	500

CLASS B (OPEN CASE)

FREQUENCY (MHz)	DISTANCE (m)	FIELD STRENGTH (uV/m)
30 - 88	3	199.5
88 - 216	3	298.5
216 - 960	3	398.1

CLASS A

FREQUENCY (MHz)	DISTANCE (m)	FIELD STRENGTH (uV/m)
30 - 88	3	316.3
88 - 216	3	473.2
216 - 960	3	613.0
ABOVE 960	3	1000.0

- NOTE : 1. IN THE EMISSION TABLES ABOVE, THE TIGHTER LIMIT APPLIES AT THE BAND EDGES.
2. DISTANCE REFERS TO THE DISTANCE BETWEEN MEASURING INSTRUMENT, ANTENNA, AND THE CLOSEST POINT OF ANY PART OF THE DEVICE OR SYSTEM.

6.7 RADIATED EMISSION TEST RESULT

THE FREQUENCY SPECTRUM FROM 30 MHz TO 2 GHz WAS INVESTIGATED. ALL READINGS UNDER 1 GHz ARE QUASI-PEAK VALUES WITH A RESOLUTION BANDWIDTH OF 120 KHz. MEASUREMENTS WERE MADE AT 3 METERS.

THE MEASUREMENTS ABOVE 1 GHz WITH A RESOLUTION BANDWIDTH OF 1 MHz ARE PEAK READING AT A DISTANCE OF 3 METERS.

TEMPERATURE : 28 C

HUMIDITY : 78 %RH

FREQ. (MHz)	CABLE LOSS (dB)	ANT. FACTOR (dB)	READING (dBuV)		EMISSION (uV)		LMTS (uV)
			HORIZ	VERT	HORIZ	VERT	
333.6	1.20	14.7	*	17.09	*	44.62	200
467.0	2.60	17.0	17.28	*	69.82	*	200
533.4	3.00	17.9	16.28	21.37	72.28	129.9	200
669.2	3.30	20.1	18.22	16.49	121.5	98.74	200
869.1	3.80	22.1	*	12.96	*	87.70	200

- REMARKS :
- (1). MEASUREMENT DOES NOT APPLY FOR THIS FREQUENCY.
 - (2). THE MAXIMUM CONDITION WAS WITH THE MONITOR POWER CORD CONNECTED TO THE PERSONAL COMPUTER.
 - (3). CPU : PENTIUM II - 333MHz CLOCK CHIP : 66MHz
 - (4). SAMPLE CALCULATION
 $20 \text{ LOG}(\text{EMISSION}) \text{ uV/m} = \text{CABLE LOSS (dB)} + \text{FACTOR (dB)} + \text{READING (dBuV/m)}$
 - (5). TEST EQUIPMENT PLEASE SEE 5.1
 - (6). UNCERTAINTY IN RADIATED EMISSION MEASURED IS $\pm 4\text{dB}$
 - (7). ANY DEPARTURE FROM SPECIFICATION : N/A

SIGNED BY TESTING ENGINEER :

Taylor auth

6.7 RADIATED EMISSION TEST RESULT

THE FREQUENCY SPECTRUM FROM 30 MHz TO 2 GHz WAS INVESTIGATED. ALL READINGS UNDER 1 GHz ARE QUASI-PEAK VALUES WITH A RESOLUTION BANDWIDTH OF 120 KHz. MEASUREMENTS WERE MADE AT 3 METERS.

THE MEASUREMENTS ABOVE 1 GHz WITH A RESOLUTION BANDWIDTH OF 1 MHz ARE PEAK READING AT A DISTANCE OF 3 METERS.

TEMPERATURE : 28 C HUMIDITY : 78 %RH

FREQ. (MHz)	CABLE LOSS (dB)	ANT. FACTOR (dB)	READING (dBuV)		EMISSION (uV)		LMTS (uV)
			HORIZ	VERT	HORIZ	VERT	
98.87	1.20	7.40	22.86	23.54	37.41	40.45	150
198.8	1.70	9.9	11.23	17.89	33.00	29.82	150
399.6	2.20	15.6	*	15.85	*	48.14	200
500.5	2.70	17.2	14.93	14.91	55.14	55.01	200
799.2	3.50	20.6	13.79	*	78.43	*	200

- REMARKS : (1). MEASUREMENT DOES NOT APPLY FOR THIS FREQUENCY.
- (2). THE MAXIMUM CONDITION WAS WITH THE MONITOR POWER CORD CONNECTED TO THE PERSONAL COMPUTER.
- (3). CPU : PENTIUM II - 400MHz CLOCK CHIP : 100MHz
- (4). SAMPLE CALCULATION
 $20 \text{ LOG (EMISSION) } \mu\text{V/m} = \text{CABLE LOSS (dB)} + \text{FACTOR (dB)} + \text{READING (dBuV/m)}$
- (5). TEST EQUIPMENT PLEASE SEE 5.1
- (6). UNCERTAINTY IN RADIATED EMISSION MEASURED IS $\pm 4\text{dB}$
- (7). ANY DEPARTURE FROM SPECIFICATION : N/A

SIGNED BY TESTING ENGINEER :

Taylor auth