

Installation guidelines

The reference to NEXT CAM PG+ throughout this manual includes the model NEXT CAM P9M0, NEXT CAM P8M0, and NEXT CAM P8M1.

- ▲ **CAUTION:** Only qualified personnel may install this equipment. Place this device in non-hazardous indoor locations only.
- **Important:** Check the device and the entire alarm system weekly to ensure optimal performance.

Figure 1: NEXT CAM PG+

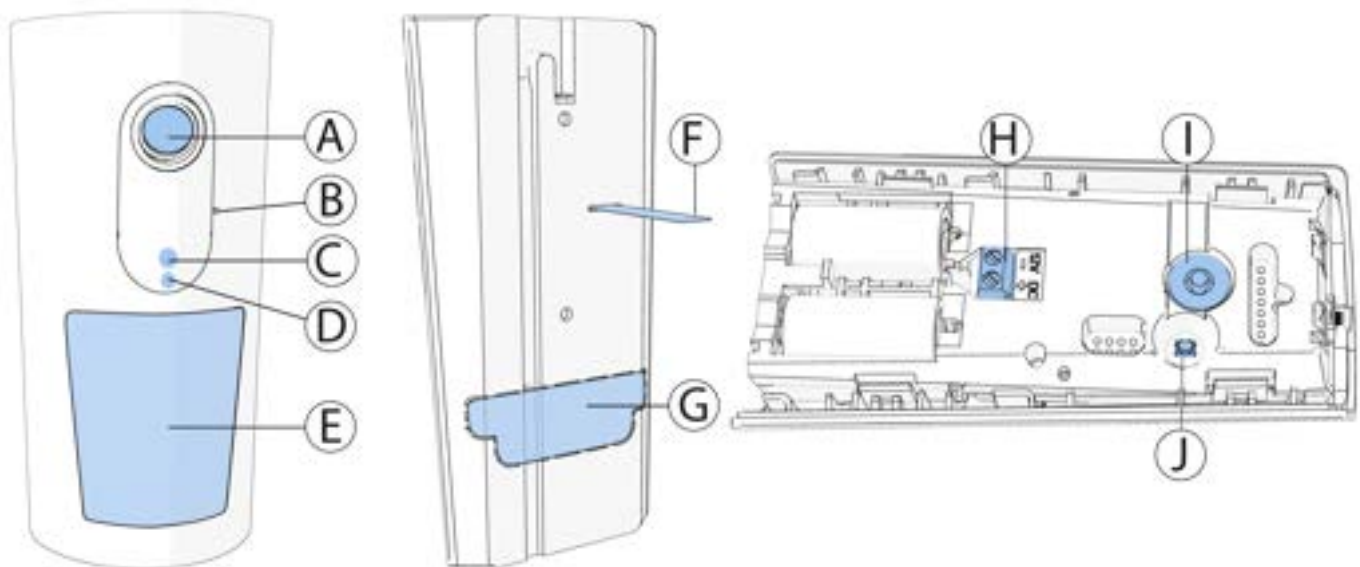

Callout	Description
A	Camera lens
B	Microphone
C	LED
D	Light sensor
E	PIR lens
F	Battery pull-tab
G	Break-away segment
H	Terminal block
I	Tamper switch
J	Enroll button

For more information refer to section [About NEXT CAM PG+](#) .



Figure 2: Optimizing detection and avoiding false alarms

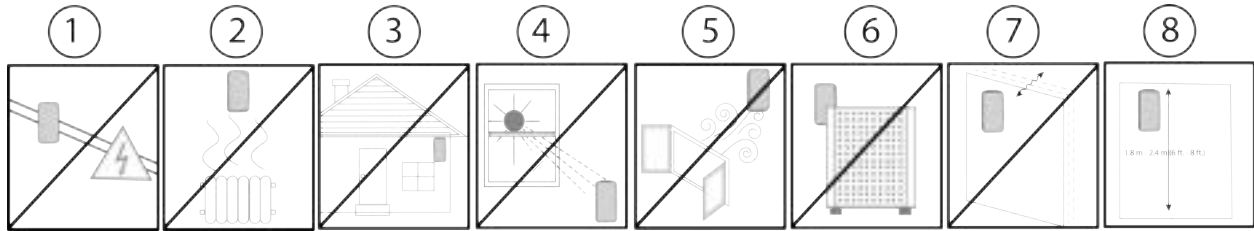

1. Do not install near high-voltage electrical lines.
2. Keep away from heat sources.
3. Do not install outdoors.
4. Avoid direct sunlight.
5. Do not expose to air drafts.
6. Do not install behind partitions.
7. Do not mount on an unstable surface.
8. Install on a solid and stable surface at a height of 1.8 m to 2.4 m (6 ft. to 8 ft.).

⚠ WARNING: Do not obscure partially or completely the detector's field of view.

Enrolling the device

1. Refer to the control panel installation manual for the complete set of enrollment instructions and testing procedures.
 2. From the **Installation** menu, enter the **Device enrollment** menu and select the option to add a new device.
 3. Remove the battery pull-tab to power on the device and begin the auto-enrollment process. If the battery pull-tab is not available or if the device does not automatically enroll, open the device cover to trigger the enrollment. Alternatively, press the enroll button until the orange LED light turns on. See [Figure 1](#).
 4. If requested, enter the PIN code printed on the device label.
 5. To manually enroll the device:
 - a. Scan the QR Code on the device box, using the IQ4 camera if available, or see step b.
 - b. Manually enter the device ID, printed on the product label, in the format ID:145-xxxx.
- ⓘ Note:** If the device has been powered up for more than 48 hours it will be identified by the system only after the device has been reset.

The NEXT CAM PG+ is enrolled with device ID 145-XXXX. In fall back mode it enrolls as NEXT CAM PG2 with device ID 140-XXXX.

6. Select the desired zone.
7. Configure any device parameters that are required.
8. Mount and test the device. See [Local diagnostics test](#) for information on testing the device.

Configuring the device parameters

Enter the **DEVICE SETTINGS** menu and select the required configuration as described in the following table.

Option	Action
General configuration options	
Alarm LED	Define whether the alarm LED indication will be activated. Optional settings: LED ON (default) and LED OFF .
Event counter	Define whether an alarm will be activated upon continued motion (low sensitivity) or upon a single alarm event (high sensitivity).. Optional settings: LOW sensitivity (default) and HIGH sensitivity .
Disarm activity	Define whether the device is active when the system is disarmed. Optional settings: NOT Active (default), no delay , 5 s delay , 15 s delay , 30 s delay , 1 min delay , 2 min delay , 5 min delay , 10 min delay , 20 min delay and 60 min delay .
AC monitoring	Determine whether the device is connected to AC power. When enabled, the device reports power failure and power restore events. Optional settings: Disabled (default) and Enabled .
AC LED behavior	Define whether the LED lights green when connected to AC power. Optional settings: Always OFF (default) and Match AC .
Temperature reporting	Define the device temperature reporting mechanism. Optional settings: Disabled (default). For further configuration options, refer to the control panel installation guide.
Camera configuration options	
Image color	Determine whether the image will be in black and white or color. Optional settings: Black & White (default) and Color .
Alarm image resolution	Set the resolution of an image taken during an alarm. Optional settings: VGA: 640 x 480 , QVGA: 320 x 240 (default), QQVGA: 160 x 120
On-demand image resolution	Set the resolution of an image taken for an on-demand image request. Optional settings: HD: 1280 x 720 , VGA: 640 x 480 , QVGA: 320 x 240 (default), QQVGA: 160 x 120
Image quality	Set the quality of an image taken during an alarm. Optional settings: Low (default), High .
Image brightness	Set the brightness of the image. Normal (default) is recommended for most conditions. Optional settings: Normal (default), -3 (lowest), -2 , -1 , +1 , +2 , and +3 (highest).
Image contrast	Set the contrast of the image. Normal (default) is recommended for most conditions. Optional settings: Normal (default), -3 lowest), -2 , -1 , +1 , +2 , and +3 (highest).
Microphone settings	Determine whether to activate the microphone. When set to enable, the microphone records sound only during image capturing. Optional settings: Disable (default) and Enable .

Installing the pet mask

Install the pet mask if you require pet immunity. The optimal installation height for pet immunity is 2.1 m (7 ft.), measured from the center of the device. Pet immunity is for pets weighing up to 38 kg (85 lb).

- ⓘ **Note:** Pet immunity is not supported at heights of 2.4 m (8 ft.) and above. Do not install the pet mask if you are mounting the device at this height or above.

Table 1: Required mounting height

Distance to opposite wall	Mounting height
8 m (26 ft) or less	1.8 to 2.1 m (6 ft to 7 ft)
8 m to 12 m (26 ft to 39 ft)	2.1 m (7 ft)

1. To open the device cover, use a screwdriver to loosen the cover screw located on the underside of the device. See A in the following figure. Separate the base from the cover. See B in the following figure.

Figure 3: Device cover removal

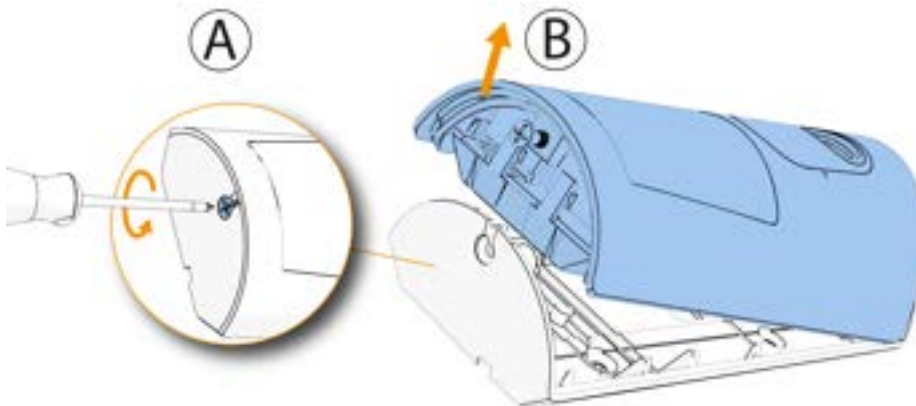

2. To extract the internal assembly, use a screwdriver to open the four clips. See A in the following figure.

Figure 4: Extracting the internal assembly

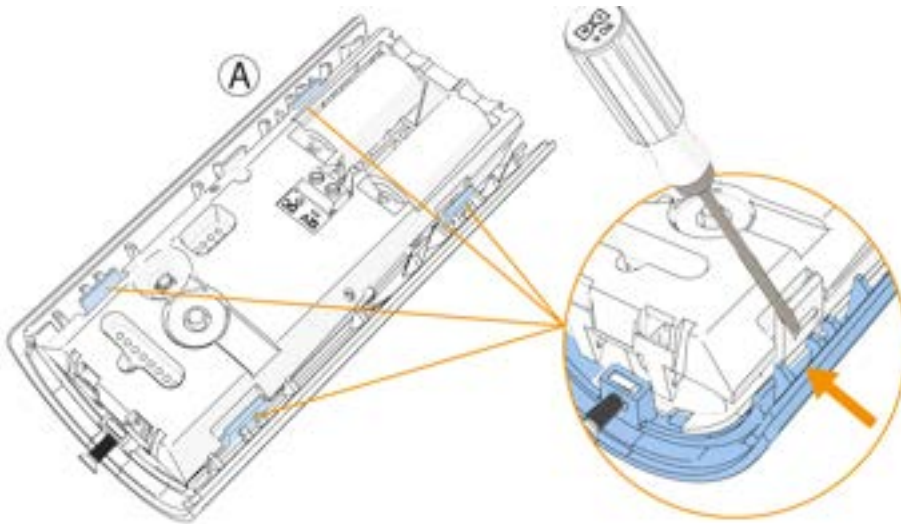

3. Insert the tabs at the base of the pet mask into the bottom holes and align the tabs on the sides with the holes on both sides. See the following figure.

Figure 5: Inserting the pet mask

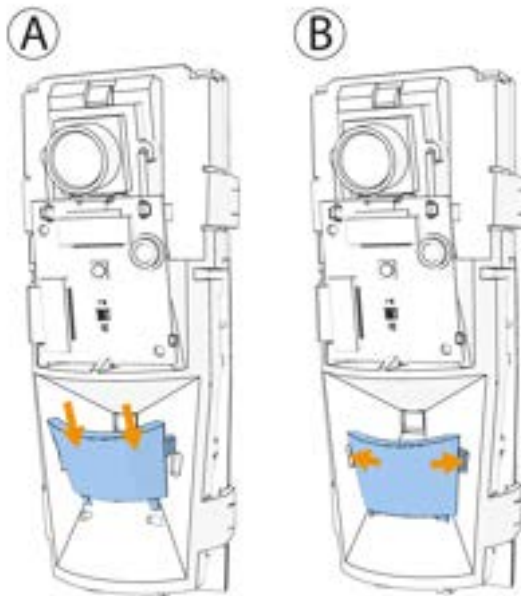

4. Press down gently to install the pet mask.
 5. Reassemble the internal assembly.
- Note:** Ensure that the microphone seal is in place. See the following image.

Figure 6: Microphone seal



6. To close the device cover, clip the cover onto the device base and tighten the cover screw. See the following figure.

Figure 7: Closing the device cover

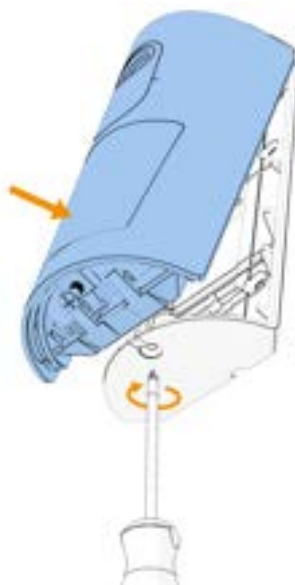

Removing the pet mask

Remove the pet mask if you do not require pet immunity.

1. Open the device cover. See [Figure 3](#).
2. To extract the internal assembly, use a screwdriver to open the four clips. See [Figure 4](#).
3. Gently remove the pet mask. See the following figure.

Figure 8: Removing the pet mask

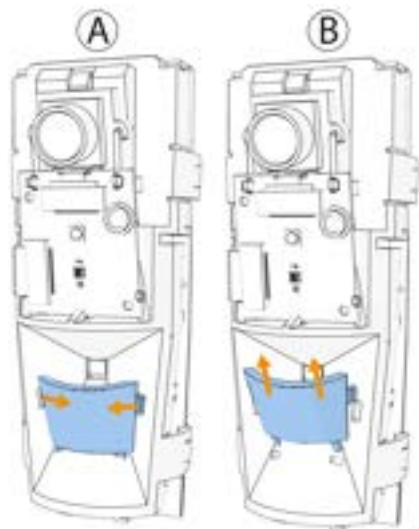

4. Reassemble the internal assembly.
 - ⓘ **Note:** To maintain the position of the microphone seal when removing the pet mask make sure that the microphone seal is in place, and replace it if necessary. See [Figure 6](#).
5. Close the device cover. See [Figure 7](#).

Mounting the device using screws

- ⓘ **Note:** Make sure to fasten the break-away segment to the frame. If the device is forcibly removed from the wall, this segment will break away from the base, causing the tamper switch to open.
1. To open the device cover, use a screwdriver to loosen the cover screw located on the underside of the device. See [Figure 3](#).
 2. Identify the holes that match the mounting option, then drill out those holes. See the following figure for mounting options.

Figure 9: Mounting options

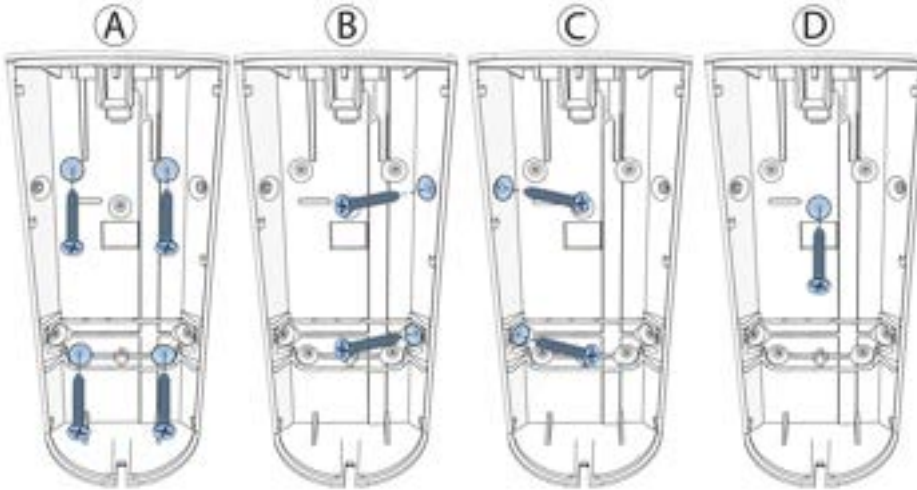

Callout	Description
A	Flat wall installation. See the note below the table.
B	Right corner installation.
C	Left corner installation.
D	BR-1/2/3 bracket installation. Use the screw from the BR-1/2/3 installation kit.

ⓘ **Note:** For flat wall installation, use two screws diagonally to include the tamper option, or two screws horizontally to exclude the tamper option. Four screws can also be used.

3. Press the base against the wall at the selected mounting position and mark the drilling points through the mounting holes.
4. Drill the required holes.
5. Screw the base to the wall.
6. Close the device cover. See [Figure 7](#).

Optional: Mounting the device using a bracket

For more information see the BR-1/2/3 manual (DE1781-).

➤ **Important:** When mounted using the BR-1, BR-2, or BR-3 bracket, back tamper protection is not available.

ⓘ **Note:** Mounting the device using a bracket is not approved by EN.

1. To mount the device on a flat wall with the option to change the angle of the device, use the BR-1 bracket. See the following figure for the assembly of the BR-1 bracket on the wall.

Figure 10: Wall-mount bracket (BR-1) installation

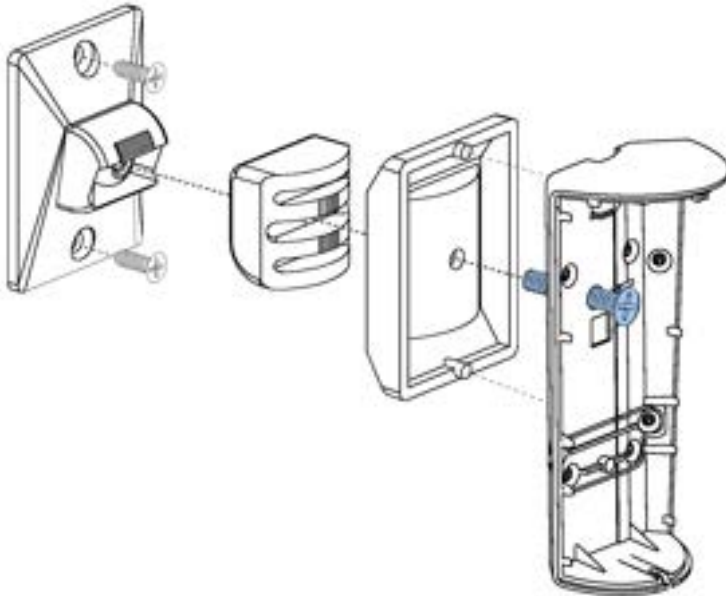

2. To mount the device in the corner with the option to change the angle of the device, use the BR-2 bracket. See the following figure for the assembly of the BR-2 bracket on the wall.

Figure 11: Corner-mount bracket (BR-2) installation

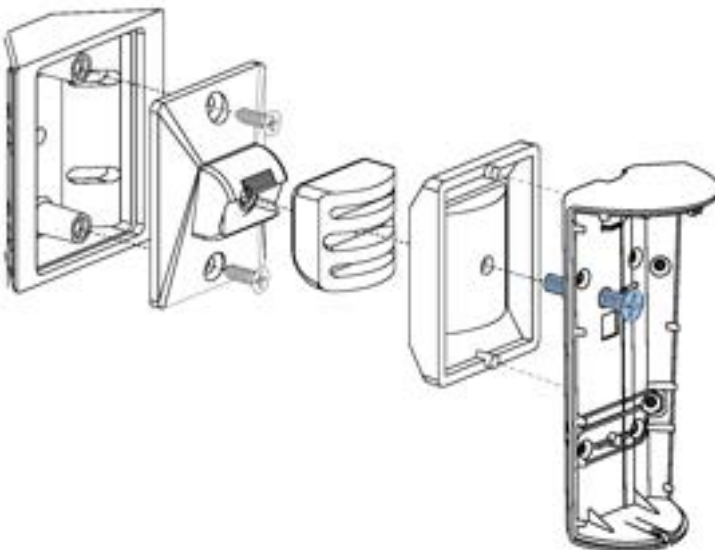

3. To mount the device on the ceiling with the option to change the angle of the device, use the BR-3 bracket. See the following figure for the assembly of the BR-3 bracket on the ceiling.

Figure 12: Ceiling-mount bracket (BR-3) installation

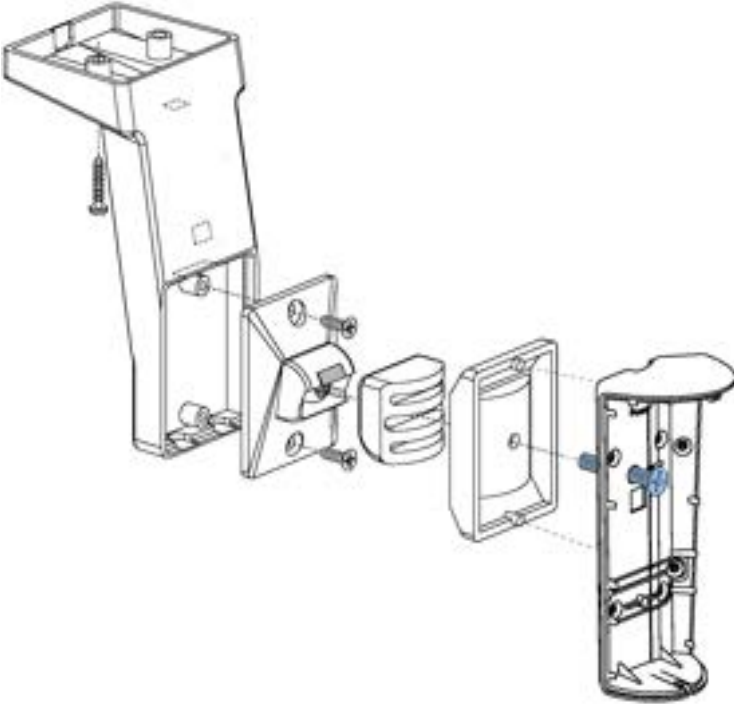

Replacing the battery

- ▲ **CAUTION:** Risk of explosion if battery is replaced by an incorrect type. Dispose of used batteries according to the manufacturer's instructions and according to local rules and regulations.
 - ⓘ **Note:** It is recommended to wait about 1 minute after battery removal before inserting the new battery.
1. Remove the device cover. See [Figure 3](#).
 2. Remove the batteries. See A in the following figure.
 3. Insert the new batteries while observing battery polarity. See B in the following figure.

Figure 13: Battery removal and insertion

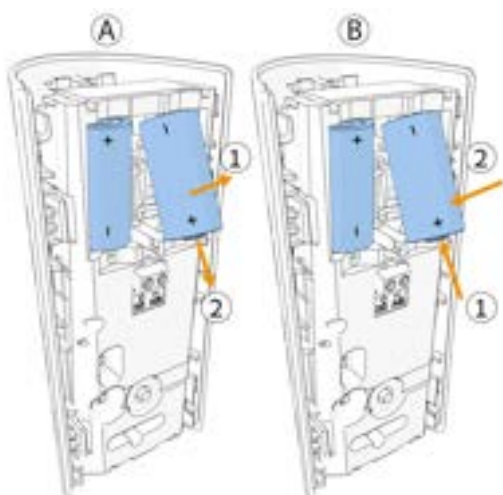

4. Press down on both batteries until they fit into place.
 5. Close the device cover and fasten the cover screw. See [Figure 7](#).
- ⓘ **Note:** After restoring a low battery, the system may take up to 5 minutes to clear the trouble.

Optional: wiring the power cable

- **Important:** Use only safety approved AC/DC power supply or another DC source which is certified to IEC/EN/UL 62368-1 with rated voltage of 12 VDC and rated current of 1 A.

1. Mark the cable 110 mm from the end. See the following figure.

Figure 14: Marking the cable



2. Remove the device cover. See [Figure 3](#).
3. Break the plastic ledge between the two battery holders. See A in [Figure 15](#).

Figure 15: Wiring with the cable

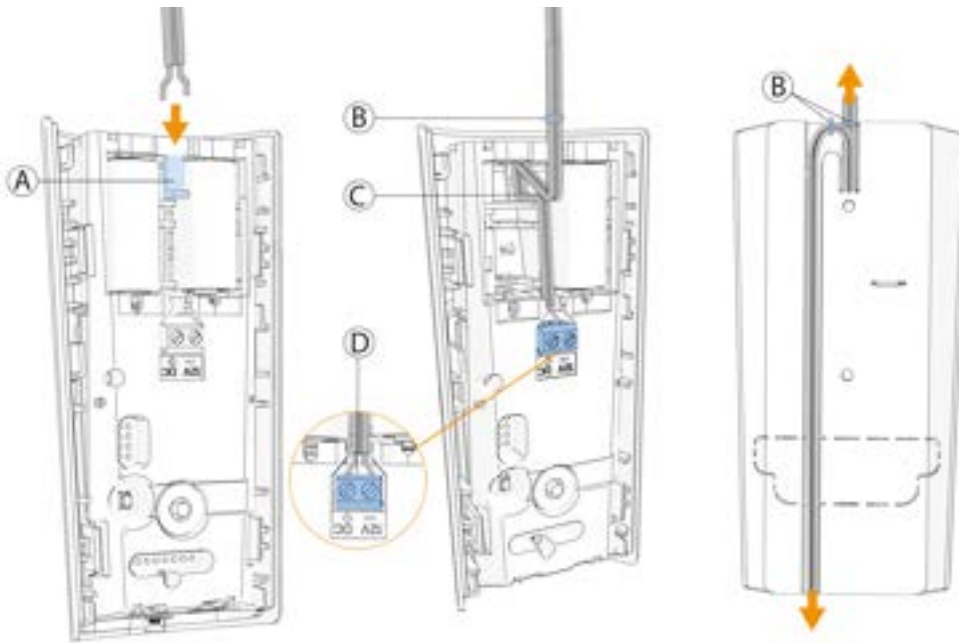

4. Insert the cable to the device.
5. Attach the cable to the terminal block. See D in [Figure 15](#).
6. Adjust the cable to create a fold in the position shown in C in [Figure 15](#).
7. Pull the cable through so that the 110 mm mark is adjusted to the top of the device. See B in [Figure 15](#).
8. Mount the device.
9. Connect the power supply to the AC outlet.

Local diagnostics test

After power-up or closing the cover, the device automatically enters Test Mode for 15 minutes. To manually enter the devices into Test Mode refer to the Control Panel Installer Guide.

1. Before you start the test, remove the device cover from the base. See [Figure 3](#).
2. Close the cover to return the tamper switch to its normal position.
3. The device enters a two-minute stability period. During this time the red LED blinks.
4. Walk-test the coverage area. See the figure below. Walk across the far end of the coverage pattern in both directions. The red LED lights each time your motion is detected followed by 3 LED blinks.

The following table indicates received signal strength indication.

Table 2: Signal strength indication

LED response	Reception
Green LED blinks	Strong
Orange LED blinks	Good
Red LED blinks	Poor
No blinks	No communication

► **Important:** Reliable reception must be assured. Therefore, poor signal strength is not acceptable. If you receive a poor signal from the device, relocate it and re-test until a strong signal strength is received.

ⓘ **Note:** It is recommended to have a strong signal strength and you must verify the signal strength using the control panel's diagnostic test. For detailed Diagnostics Test instructions, refer to the control panel installer guide.

Figure 16: Coverage Pattern & Walk-test

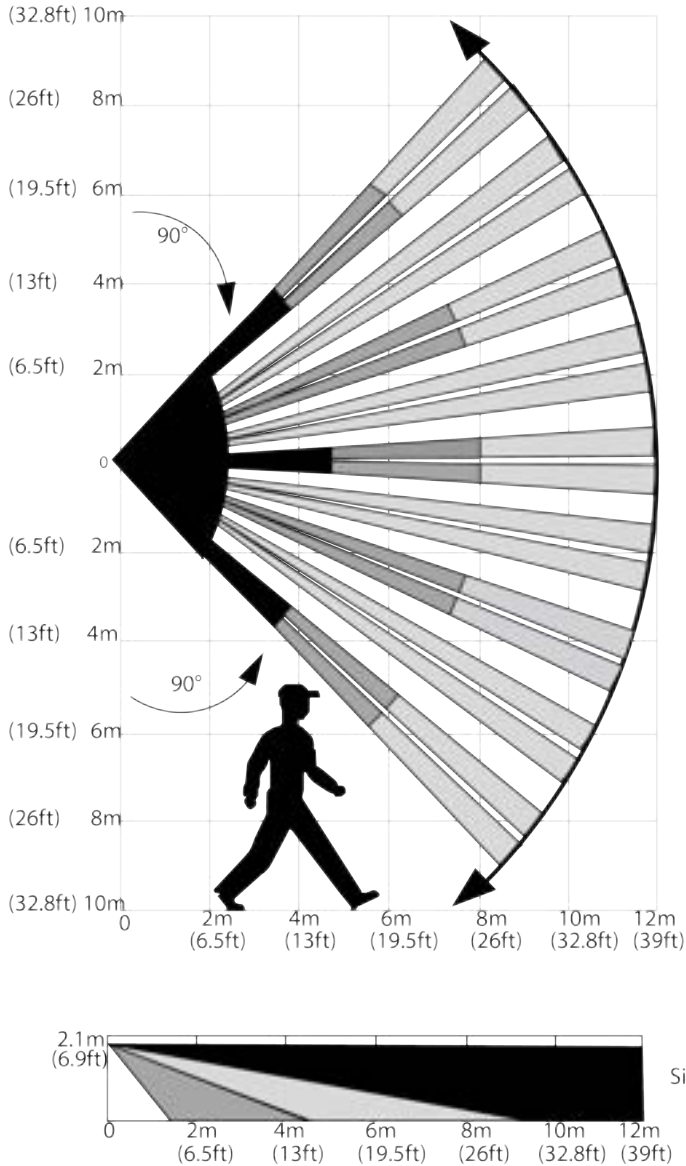

Fresnel and cylinder type lens with optical attenuation (pet mask) in the lower pattern part of the lens. Number of beams / curtains: 18 Fresnel far, 10 Cylinder mid, 6 Cylinder close.

- **Important:** Instruct the user to walk test at least once a week to verify proper function of the device.

Specifications

Frequency band	868 to 869 MHz, 912 to 919 MHz
Maximum Tx Power	+14 dBm @ 868 MHz
Modulation	GFSK
Communication Protocol	PowerG
Battery Type	6V Lithium battery Panasonic, Duracell, and GP only (two CR-123A 3V batteries)
Battery Life	5 years with typical use at room temperature 25°C (77°F)
Low Battery Threshold	4.5 V at room temperature 25°C (77°F)
Nominal Operating Voltage	6 V
Current Consumption	Standby: 20 uA. Maximum: 500 mA
Operating Temperature	-10°C (14°F) to 50°C (122°F).
Storage Temperature	-20°C (-4°F) to 60°C (140°F)
Relative Humidity	Up to 95% non-condensing
Dimensions (LxWxD)	125 x 63 x 60 mm (4.9 in. x 2.5 in. x 2.4 in.)
Weight (including battery)	200 g (7 oz)
True Motion Event Verification	2 remote selections: 1 (OFF) or 2 (ON) motion events
IR Illumination	10 m (33 ft)
Frame Rate	Fixed at 2 fps
Max. coverage	12 x 12 m (39 x 39 ft) / 90°
Pet immunity	Up to 38 kg (85 lb)
Color	White
Power supply	12 VDC +/- 10% / 1A

Compliance with standards

NEXT CAM PG+ complies with the following standards:

NEXT CAM P9M0	FCC (912 to 919 MHz): 47CFR part 15.247
NEXT CAM P8M0 NEXT CAM P8M1	Europe (868 Mhz): EN 300220, EN 301489, EN 50130-4, EN 50130-5, EN 61000-6-3, EN 62368-1, EN 50131-1, EN 50131-2-2 Grade 2, Class II and EN 50131-6 Type C or Type B UK (868 MHz): is suitable for use in systems installed to conform to PD6662 at Grade 2 and environmental class II, DD243 and BS8243



FCC Compliance Statement

This device complies with FCC Rules Part 15 license-exempt standard(s). Operation is subject to two conditions:

(1) This device may not cause harmful interference, and (2) this device must accept any interference that may be received or that may cause undesired operation.

Note: The digital circuit of this device has been tested and found to comply with the limits for a Class B digital device, pursuant to part 15 of the FCC Rules. These limits are designed to provide reasonable protection against harmful interference in a residential installation. This equipment generates, uses and can radiate radio frequency energy and, if not installed and used in accordance with the instructions, may cause harmful interference to radio communications. However, there is no guarantee that interference will not occur in a particular installation. If this equipment does cause harmful interference to radio or television reception, which can be determined by turning the equipment off and on, the user is encouraged to try to correct the interference by one or more of the following measures:

- Reorient or relocate the receiving antenna.
- Increase the separation between the equipment and receiver.
- Connect the equipment into an outlet on a circuit different from that to which the receiver is connected.
- Consult the dealer or an experienced radio/TV technician for help.

WARNING: Changes or modifications to this equipment not expressly approved by the party responsible for compliance (Visonic Ltd.) could void the user's authority to operate the equipment.

To comply with FCC RF exposure compliance requirements, the device should be located at a distance of at least 20 cm from all persons during normal operation. The antennas used for this product must not be co-located or operated in conjunction with any other antenna or transmitter.

Simplified EU declaration of conformity

Hereby, Visonic Ltd. declares that the radio equipment type NEXT CAM PG+ is in compliance with Directive 2014/53/EU. The full text of the EU declaration of conformity is available at the following internet address: <http://www.visonic.com/download-center>.

Certified by Applica Test & Certification AS in accordance with EN 50131-2-2, EN 50131-5-3, EN 50131-6, EN 50130-4, EN 50130-5. Security Grade 2 and Environmental Class II.

Safety Instructions

Read the safety information before you install the equipment.

The detector shall be installed and used within an environment that provides the pollution degree max 2 and over voltages category II in non-hazardous locations, indoor only. The equipment is designed to be installed by SERVICE PERSONS only; (SERVICE PERSON is defined as a person having the appropriate technical training and experience necessary to be aware of hazards to which that person may be exposed in performing a task and of measures to minimize the risks to that person or other persons).

▲ CAUTION: Use the type of power source indicated in the user manual. Use of a different power source may result in fire or electric shock. Place the detector near a wall outlet where the plug can be easily unplugged.

W.E.E Product recycling declaration

	<p>For information regarding the recycling of this product you must contact the company from which you originally purchased it. If you are discarding this product and not returning it for repair then you must ensure that it is returned as identified by your supplier. This product is not to be thrown away with everyday waste. Directive 2012/19/EU Waste Electrical and Electronic Equipment.</p>
---	--

About NEXT CAM PG+

The NEXT CAM PG+ is a two-way, microprocessor-controlled, wireless digital PIR detector with integrated camera and microphone for alarm verification. Activated upon PIR detection or upon demand, the device sends clear images with optional audio to the monitoring station. It enables accurate status assessment of the premises.

After enrollment and configuration the NEXT CAM PG+ captures burglary image clips which are sent to the monitoring station for burglary verification once the system is armed and upon occurrence of a burglary alarm.

The camera can also capture images upon occurrence of non-burglary alarms, such as fire, duress, emergency, and panic.

The device has the following features:

- Operating range up to 12 meters (40 ft).
- The advanced True Motion Recognition™ algorithm (patented) distinguishes between the true motion of an intruder and any other disturbances which may cause false alarms.
- Built-in link quality indicators.
- No vertical adjustment required.
- Temperature compensation.
- Sealed chamber protects the optical system from insects.
- Front cover and back tamper, for improved tamper protection.
- White light protection.

The camera has the following features:

- 90° angle camera overlaps PIR field of view.
- 10 meter (33 ft) range in complete darkness overlaps PIR range.
- Target Specific Imaging™ (TSI) technology is used for distinction between humans and pets weighing up to 38 kg (85lb).
- Optional audio with images for listen-in.
- Images multiplexed from all cameras.
- Color and back and white images.

- Auto-setup (brightness, contrast).
- Camera tuning by simple walk-test.
- Day and night CMOS camera, with IR illumination.
- Instant capture guarantees capture of fast moving intruder.
- Camera operation modes:
 - Post alarm – pictures are taken after detection by detector.
 - On demand – pictures are taken after a command from the monitoring station.
- An event records two images per second. 10 to 15 images in total per event. This can be customized by request.
- Temperature sensing and reporting.
- Remote firmware upgrade.
- VGA image resolution for alarm and on-demand images.
- HD image resolution for on-demand requests.
- Optional power connection.

Warranty

Visonic Ltd. (“**Seller**”) warrants the Products to the original purchaser only (the “**Buyer**”) against defective workmanship and materials under normal use of the Products for a period of twelve (12) months from the date of shipment by the Seller.

This Warranty is absolutely conditional upon the Products having been properly installed, maintained and operated under conditions of normal use in accordance with the Seller's recommended installation and operation instructions. Products which have become defective for any other reason, according to the Seller's discretion, such as improper installation, failure to follow recommended installation and operational instructions, neglect, willful damage, misuse or vandalism, accidental damage, alteration or tampering, or repair by anyone other than the Seller, are not covered by this Warranty.

There is absolutely no warranty on software, and all software products are sold as a user license under the terms of the software license agreement included with such Product.

The Seller does not represent that Products may not be compromised and/or circumvented or that the Products will prevent any death and/or personal injury and/or damage to property resulting from burglary, robbery, fire or otherwise, or that the Products will in all cases provide adequate warning or protection. The Products, properly installed and maintained, only reduce the risk of such events without warning and it is not a guarantee or insurance that such events will not occur.

Conditions to Void Warranty: This warranty applies only to defects in parts and workmanship relating to normal use of the Products. It does not cover:

- damage incurred in shipping or handling;
- damage caused by disaster such as fire, flood, wind, earthquake or lightning;
- damage due to causes beyond the control of the Seller such as excessive voltage, mechanical shock or water damage;
- damage caused by unauthorized attachment, alterations, modifications or foreign objects being used with or in conjunction with the Products;
- damage caused by peripherals (unless such peripherals were supplied by the Seller);
- defects caused by failure to provide a suitable installation environment for the products;
- damage caused by use of the Products for purposes other than those for which they were designed;
- damage from improper maintenance;
- damage arising out of any other abuse, mishandling or improper application of the Products.

Items Not Covered by Warranty: In addition to the items which void the Warranty, the following items shall not be covered by Warranty: (i) freight cost to the repair centre; (ii) customs fees, taxes, or VAT that may be due; (iii) Products which are not identified with the Seller's product label and lot number or serial number; (iv) Products disassembled or repaired in such a manner as to adversely affect performance or prevent adequate inspection or testing to verify any warranty claim. Access cards or tags returned for replacement under warranty will be credited or replaced at the Seller's option.

This warranty is exclusive and expressly in lieu of all other warranties, obligations or liabilities, whether written, oral, express or implied, including any warranty of merchantability or fitness for a particular purpose, or otherwise. In no case shall the SELLER be liable to anyone for any consequential or incidental damages for breach of this warranty or any other warranties whatsoever, as aforesaid.

The Seller shall in no event be liable for any special, indirect, incidental, consequential or punitive damages or for loss, damage, or expense, including loss of use, profits, revenue, or goodwill, directly or indirectly arising from Purchaser's use or inability to use the Product, or for loss or destruction of other property or from any other cause, even if Seller has been advised of the possibility of such damage.

The SELLER shall have no liability for any death, personal and/or bodily injury and/or damage to property or other loss whether direct, indirect, incidental, consequential or otherwise, based on a claim that the Product failed to function. However, if the Seller is held liable, whether directly or indirectly, for any loss or damage arising under this limited warranty, **the SELLER'S maximum liability (if any) shall not in any case exceed the purchase price of the Product INVOLVED**, which shall be fixed as liquidated damages and not as a penalty, and shall be the complete and exclusive remedy against the Seller.

When accepting the delivery of the Products, the buyer agrees to the said conditions of sale and warranty and he recognizes having been informed of.

Some jurisdictions do not allow the exclusion or limitation of incidental or consequential damages, so these limitations may not apply under certain circumstances.

The Seller shall be under no liability whatsoever arising out of the corruption and/or malfunctioning of any telecommunication or electronic equipment or any programs.

The Seller's obligations under this Warranty are limited solely to repair and/or replace at the Seller's discretion any Product or part thereof that may prove defective. Any repair and/or replacement shall not extend the original Warranty period. The Seller shall not be responsible for dismantling and/or reinstallation costs. To exercise this Warranty the Products must be returned to the Seller freight pre-paid and insured. All freight and insurance costs are the responsibility of the Buyer and are not included in this Warranty.

This warranty shall not be modified, varied or extended, and the Seller does not authorize any person to act on its behalf in the modification, variation or extension of this warranty. This warranty shall apply to the Products only. All products, accessories or attachments of others used in conjunction with the Products, including batteries, shall be covered solely by their own warranty, if any. The Seller shall not be liable for any damage or loss whatsoever, whether directly, indirectly, incidentally, consequentially or otherwise, caused by the malfunction of the Products due to products, accessories, or attachments of others, including batteries, used in conjunction with the Products. This Warranty is exclusive to the original Buyer and is not assignable.

This Warranty is in addition to and does not affect your legal rights. Any provision in this warranty which is contrary to the Law in the state or country where the Product is supplied shall not apply.

Governing Law: This disclaimer of warranties and limited warranty are governed by the domestic laws of Israel.

Warning

The user must follow the Seller's installation and operational instructions including testing the Product and its whole system at least once a week and to take all necessary precautions for his/her safety and the protection of his/her property.

Email: info@visonic.com

Website: www.visonic.com

D-308440 Rev. 0 (05/23)



D-308440