

## TEST REPORT

ACCORDING TO: FCC 47CFR part 15 subpart C §15.247 (FHSS) and subpart B,  
RSS-247 Issue 2:2017, RSS-Gen Issue 5, ICES-003 Issue 7:2020

FOR:

**Tyco Safety Products Canada Ltd.**

**Electronic door lock**

**Model: IQ Lockdown PG**

**FCC ID: F5323IQLOCKDOWNPG**

**IC: 160A-IQLOCKDOWNPG**

This report is in conformity with ISO/IEC 17025. The "A2LA Accredited" symbol endorsement applies only to the tests and calibrations that are listed in the scope of Hermon Laboratories accreditation. The test results relate only to the items tested.  
This test report shall not be reproduced in any form except in full with the written approval of Hermon Laboratories Ltd.



## Table of contents

1	Applicant information .....	3
2	Equipment under test attributes .....	3
3	Manufacturer information .....	3
4	Test details .....	3
5	Tests summary .....	4
6	EUT description .....	5
6.1	General information .....	5
6.2	Test configuration .....	5
6.3	Changes made in EUT .....	5
6.4	Transmitter characteristics .....	6
7	Transmitter tests according to 47CFR part 15 subpart C and RSS-247 requirements .....	7
7.1	20 dB bandwidth .....	7
7.2	Carrier frequency separation .....	10
7.3	Number of hopping frequencies .....	12
7.4	Average time of occupancy .....	15
7.5	Peak output power .....	18
7.6	Field strength of spurious emissions .....	23
7.7	Band edge radiated emissions .....	35
7.8	Conducted emissions .....	39
7.9	Antenna requirements .....	44
8	Emissions tests according to FCC 47CFR part 15 subpart B and ICES-003 requirements .....	45
8.1	Conducted emissions .....	45
8.2	Radiated emission measurements .....	53
9	APPENDIX A Test equipment and ancillaries used for tests .....	58
10	APPENDIX B Test equipment correction factors .....	59
11	APPENDIX C Measurement uncertainties .....	62
1	APPENDIX D Test laboratory description .....	63
2	APPENDIX E Specification references .....	64
3	APPENDIX F Abbreviations and acronyms .....	65

## 1 Applicant information

**Client name:** Tyco Safety Products Canada Ltd.  
**Address:** 3301 Langstaff Road, Concord, Ontario L4K 4L2, Canada  
**Telephone:** 1-647-480-0430  
**Fax:** 1-647-480-0531  
**E-mail:** [dnita@tycoint.com](mailto:dnita@tycoint.com)  
**Contact name:** Mr. Dan Nita

## 2 Equipment under test attributes

**Product name:** Electronic door lock  
**Product type:** Transceiver  
**Model(s):** IQ Lockdown PG  
**Serial number:** NA  
**Hardware version:** 90-210279  
**Software release:** NA  
**Receipt date** 09-Feb-23

## 3 Manufacturer information

**Manufacturer name:** Tyco Safety Products Canada Ltd.  
**Address:** 3301 Langstaff Road, Concord, Ontario L4K 4L2, Canada  
**Telephone:** 1-647-480-0430  
**Fax:** 1-647-480-0531  
**E-Mail:** [dnita@tycoint.com](mailto:dnita@tycoint.com)  
**Contact name:** Mr. Dan Nita

## 4 Test details

**Project ID:** 49299  
**Location:** Hermon Laboratories Ltd. P.O. Box 23, Binyamina 3055001, Israel  
**Test started:** 02-Feb-23  
**Test completed:** 09-Feb-23  
**Test specification(s):** FCC 47CFR part 15 subpart C §15.247 (FHSS) and subpart B, RSS-247 Issue 2:2017, RSS-Gen Issue 5, ICES-003 Issue 7:2020

## 5 Tests summary

### Test

#### Transmitter characteristics



Section 15.247(a)1 / RSS-247 section 5.1(c), 20 dB bandwidth	Pass
Section 15.247(b) / RSS-247 section 5.4(a), Peak output power	Pass
Section 15.247(d) / RSS-247 section 5.5, Radiated spurious emissions	Pass
Section 15.247(a)1 / RSS-247 section 5.1(b), Frequency separation	Pass
Section 15.247(a)1 / RSS-247 section 5.1(c), Number of hopping frequencies	Pass
Section 15.247(a)1 / RSS-247 section 5.1(c), Average time of occupancy	Pass
Section 15.247(i)5 / RSS-102 section 2.5, RF exposure	Pass, the exhibit to the application of certification is provided
Section 15.247(d) / RSS-247 section 5.5, Emissions at band edges	Not required
Section 15.203 / RSS-Gen section 8.3, Antenna requirements	Pass
Section 15.207(a) / RSS-Gen section 8.8, Conducted emission	Pass

#### Unintentional emissions

Section 15.107/ICES-003, Section 6.1, Class B, Conducted emission at AC power port	Pass
Section 15.109/ RSS-Gen section 7.1.2 /ICES-003, Section 6.2, Class B, Radiated emission	Pass

Testing was completed against all relevant requirements of the test standard. The results obtained indicate that the product under test complies in full with the requirements tested.

The test results relate only to the items tested. Pass/ fail decision was based on nominal values.

	Name and Title	Date	Signature
<b>Tested by:</b>	Mrs. E. Pitt, test engineer, EMC & Radio	02-Feb-23 – 09-Feb-23	
<b>Reviewed by:</b>	Mrs. S. Peysahov Sheynin, test engineer, EMC & Radio	20-Mar-23	
<b>Approved by:</b>	Mr. M. Nikishin, group leader, EMC & Radio	06-Jun-23	



## 6 EUT description

Note: The following data in this clause is provided by the customer and represents his sole responsibility

### 6.1 General information

The EUT is an Electronic door lock with PowerG radio operates at 915MHz. The EUT is equipped with an integral antenna and is powered from 3.7 VDC internal battery. The EUT has a receiver class 2.

### 6.2 Test configuration

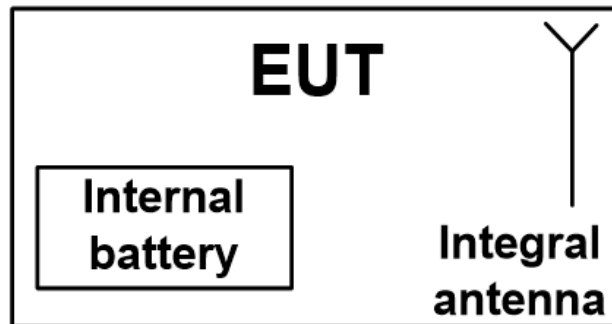

### 6.3 Changes made in EUT

No changes were implemented in the EUT during the testing.



### 6.4 Transmitter characteristics

<b>Type of equipment</b>						
X	Stand-alone (Equipment with or without its own control provisions)					
	Combined equipment (Equipment where the radio part is fully integrated within another type of equipment)					
	Plug-in card (Equipment intended for a variety of host systems)					
<b>Intended use</b>		<b>Condition of use</b>				
	fixed	Always at a distance more than 2 m from all people				
X	mobile	Always at a distance more than 20 cm from all people				
	portable	May operate at a distance closer than 20 cm to human body				
<b>Assigned frequency ranges</b>		902 – 928 MHz				
<b>Operating frequencies</b>		912.750 – 919.106 MHz				
<b>Maximum rated output power</b>		At transmitter 50 Ω RF output connector			dBm	
		Peak output power			13.1 dBm	
<b>Is transmitter output power variable?</b>		X	No			
			Yes	continuous variable		
				stepped variable with stepsize		
				minimum RF power	dBm	
		maximum RF power	dBm			
<b>Antenna connection</b>						
unique coupling		standard connector		X	integral	
				X	with temporary RF connector	
					without temporary RF connector	
<b>Antenna/s technical characteristics</b>						
Type		Manufacturer		Model number		
Helical		Ocean		H-305789		
<b>Transmitter aggregate data rate/s</b>		50 kbps				
<b>Type of modulation</b>		GFSK				
<b>Modulating test signal (baseband)</b>		PRBS				
<b>Transmitter power source</b>						
X	Battery	<b>Nominal rated voltage</b>	3.7 VDC	Battery type	Lithium Battery	
	DC	<b>Nominal rated voltage</b>				
	AC mains	<b>Nominal rated voltage</b>		Frequency		
<b>Common power source for transmitter and receiver</b>				X	yes	
					no	
<b>Spread spectrum technique used</b>		X	Frequency hopping (FHSS)			
			Digital transmission system (DTS)			
			Hybrid			
<b>Spread spectrum parameters for transmitters tested per FCC 15.247 only</b>						
FHSS	Total number of hops		50			
	Bandwidth per hop		102.7 kHz			
	Max. separation of hops		129.6 kHz			



<b>Test specification: Section 15.247(a)1, 20 dB bandwidth</b>			
<b>Test procedure:</b> Public notice DA 00-705			
<b>Test mode:</b> Compliance		<b>Verdict: PASS</b>	
<b>Date(s):</b> 05-Feb-23			
<b>Temperature:</b> 20 °C	<b>Relative Humidity:</b> 49 %	<b>Air Pressure:</b> 1008 hPa	<b>Power:</b> 3.7 VDC
<b>Remarks:</b>			

## 7 Transmitter tests according to 47CFR part 15 subpart C and RSS-247 requirements

### 7.1 20 dB bandwidth

#### 7.1.1 General

This test was performed to measure the 20 dB bandwidth of the transmitter hopping channel. Specification test limits are given in Table 7.1.1.

Table 7.1.1 The 20 dB bandwidth limits

Assigned frequency, MHz	Maximum bandwidth, kHz	Modulation envelope reference points*, dBc
902.0 – 928.0	250	20
2400.0 – 2483.5	NA	
5725.0 – 5850.0	1000	

\* - Modulation envelope reference points provided in terms of attenuation below the peak of modulated carrier.

#### 7.1.2 Test procedure

7.1.2.1 The EUT was set up as shown in Figure 7.1.1, energized and its proper operation was checked.

7.1.2.2 The EUT was set to transmit modulated carrier at maximum data rate.

7.1.2.3 The transmitter bandwidth was measured with spectrum analyzer as frequency delta between reference points on modulation envelope and provided in Table 7.1.2 and associated plot.

7.1.2.4 The test was repeated for each data rate and each modulation format.

Figure 7.1.1 The 20dB bandwidth test setup





<b>Test specification:</b> Section 15.247(a)1, 20 dB bandwidth			
<b>Test procedure:</b> Public notice DA 00-705			
<b>Test mode:</b> Compliance		<b>Verdict:</b> PASS	
<b>Date(s):</b> 05-Feb-23			
<b>Temperature:</b> 20 °C	<b>Relative Humidity:</b> 49 %	<b>Air Pressure:</b> 1008 hPa	<b>Power:</b> 3.7 VDC
<b>Remarks:</b>			

Table 7.1.2 The 20 dB bandwidth test results

ASSIGNED FREQUENCY BAND: 902-928 MHz  
DETECTOR USED: Peak  
SWEEP TIME: Auto  
VIDEO BANDWIDTH: ≥ RBW  
MODULATION ENVELOPE REFERENCE POINTS: 20.0 dBc  
FREQUENCY HOPPING: Disabled

Carrier frequency, MHz	Type of modulation	Data rate, kbps	99% bandwidth, kHz	20 dB bandwidth, kHz	Limit, kHz	Margin, kHz	Verdict
912.75	GFSK	50	96.034	102.5	250	-147.5	Pass
915.863			93.054	102.7	250	-147.3	Pass
919.106			92.842	101.0	250	-149.0	Pass

Reference numbers of test equipment used

HL 5376	HL 4136	HL 5409						
---------	---------	---------	--	--	--	--	--	--

Full description is given in Appendix A.

Plot 7.1.1 The 20 dB bandwidth test result at low frequency

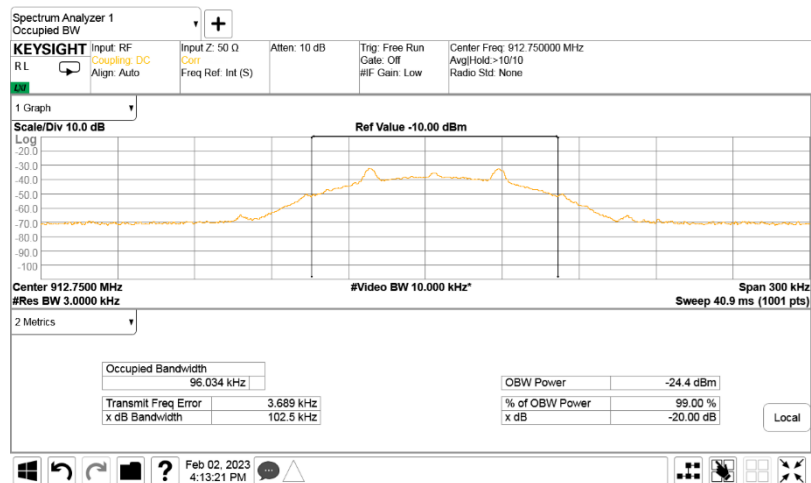





<b>Test specification: Section 15.247(a)1, 20 dB bandwidth</b>			
<b>Test procedure:</b> Public notice DA 00-705			
<b>Test mode:</b> Compliance		<b>Verdict: PASS</b>	
<b>Date(s):</b> 05-Feb-23			
<b>Temperature:</b> 20 °C	<b>Relative Humidity:</b> 49 %	<b>Air Pressure:</b> 1008 hPa	<b>Power:</b> 3.7 VDC
<b>Remarks:</b>			

Plot 7.1.2 The 20 dB bandwidth test result at mid frequency

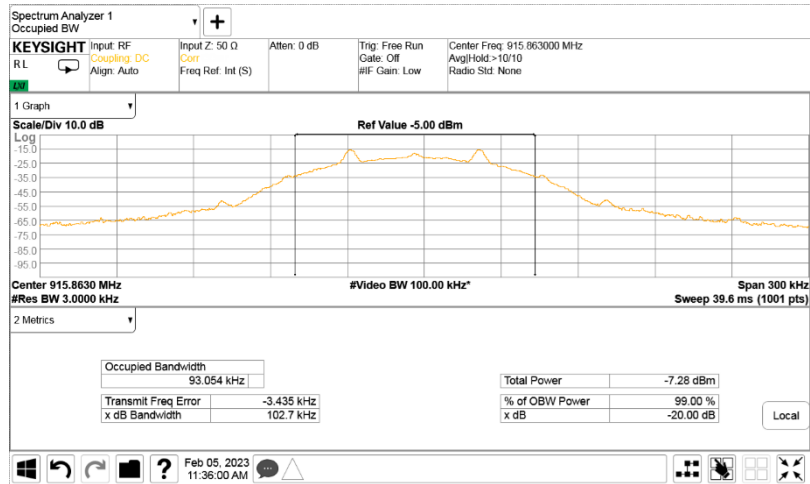

Plot 7.1.3 The 20 dB bandwidth test result at high frequency

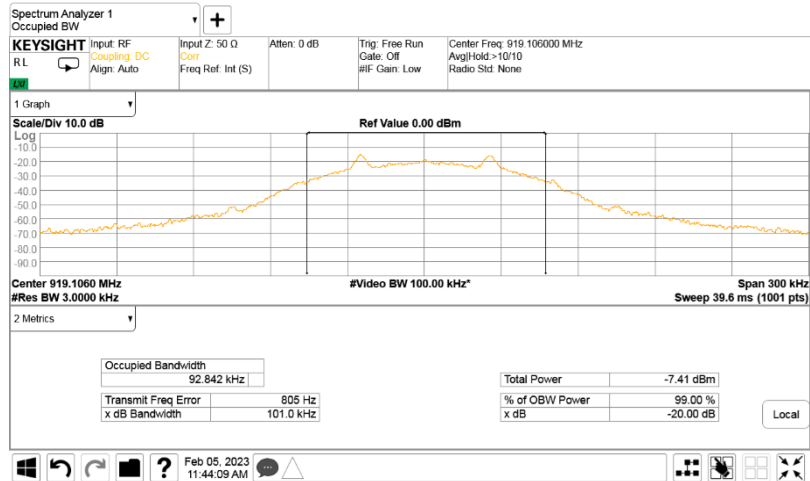



<b>Test specification:</b> Section 15.247(a)1, RSS-247 section 5.1(2), Frequency separation			
<b>Test procedure:</b> ANSI C63.10, section 7.8.2			
<b>Test mode:</b> Compliance		<b>Verdict:</b> PASS	
<b>Date(s):</b> 05-Feb-23			
<b>Temperature:</b> 20 °C	<b>Relative Humidity:</b> 49 %	<b>Air Pressure:</b> 1008 hPa	<b>Power:</b> 3.7 VDC
<b>Remarks:</b>			

## 7.2 Carrier frequency separation

### 7.2.1 General

This test was performed to measure frequency separation between the peaks of adjacent channels. Specification test limits are given in Table 7.2.1.

Table 7.2.1 Carrier frequency separation limits

Assigned frequency range, MHz	Carrier frequency separation	
	Output power 30 dBm	Output power 21 dBm
902.0 – 928.0	25 kHz or 20 dB bandwidth of the hopping channel, whichever is greater	25 kHz or two-thirds of the 20 dB bandwidth of the hopping channel, whichever is greater
2400.0 – 2483.5		
5725.0 – 5850.0		

### 7.2.2 Test procedure

- 7.2.2.1 The EUT was set up as shown in Figure 7.2.1, energized with frequency hopping function enabled and its proper operation was checked.
- 7.2.2.2 The spectrum analyzer span was set to capture the carrier frequency and both of adjacent channels, the lower and the higher. The resolution bandwidth was set wider than 1 % of the frequency span.
- 7.2.2.3 The spectrum analyzer was set in max hold mode and allowed trace to stabilize.
- 7.2.2.4 The frequency separation between the peaks of adjacent channels was measured as provided in Table 7.2.2 and associated plots.

Figure 7.2.1 Carrier frequency separation test setup





<b>Test specification:</b> Section 15.247(a)1, RSS-247 section 5.1(2), Frequency separation			
<b>Test procedure:</b> ANSI C63.10, section 7.8.2			
<b>Test mode:</b> Compliance		<b>Verdict:</b> PASS	
<b>Date(s):</b> 05-Feb-23			
<b>Temperature:</b> 20 °C	<b>Relative Humidity:</b> 49 %	<b>Air Pressure:</b> 1008 hPa	<b>Power:</b> 3.7 VDC
<b>Remarks:</b>			

Table 7.2.2 Carrier frequency separation test results

ASSIGNED FREQUENCY: 902-928 MHz  
 MODULATION: GFSK  
 BIT RATE: 50 kbps  
 DETECTOR USED: Peak  
 RESOLUTION BANDWIDTH: ≥ 1% of the span  
 VIDEO BANDWIDTH: ≥ RBW  
 FREQUENCY HOPPING: Enabled  
 20 dB BANDWIDTH: 102.7 kHz

Carrier frequency separation, kHz	Limit, kHz	Margin*	Verdict
129.6	102.7	-26.9	Pass

\* - Margin = Carrier frequency separation – specification limit.

Reference numbers of test equipment used

HL 5376	HL 4136	HL 3901				
---------	---------	---------	--	--	--	--

Full description is given in Appendix A.

Plot 7.2.1 Carrier frequency separation

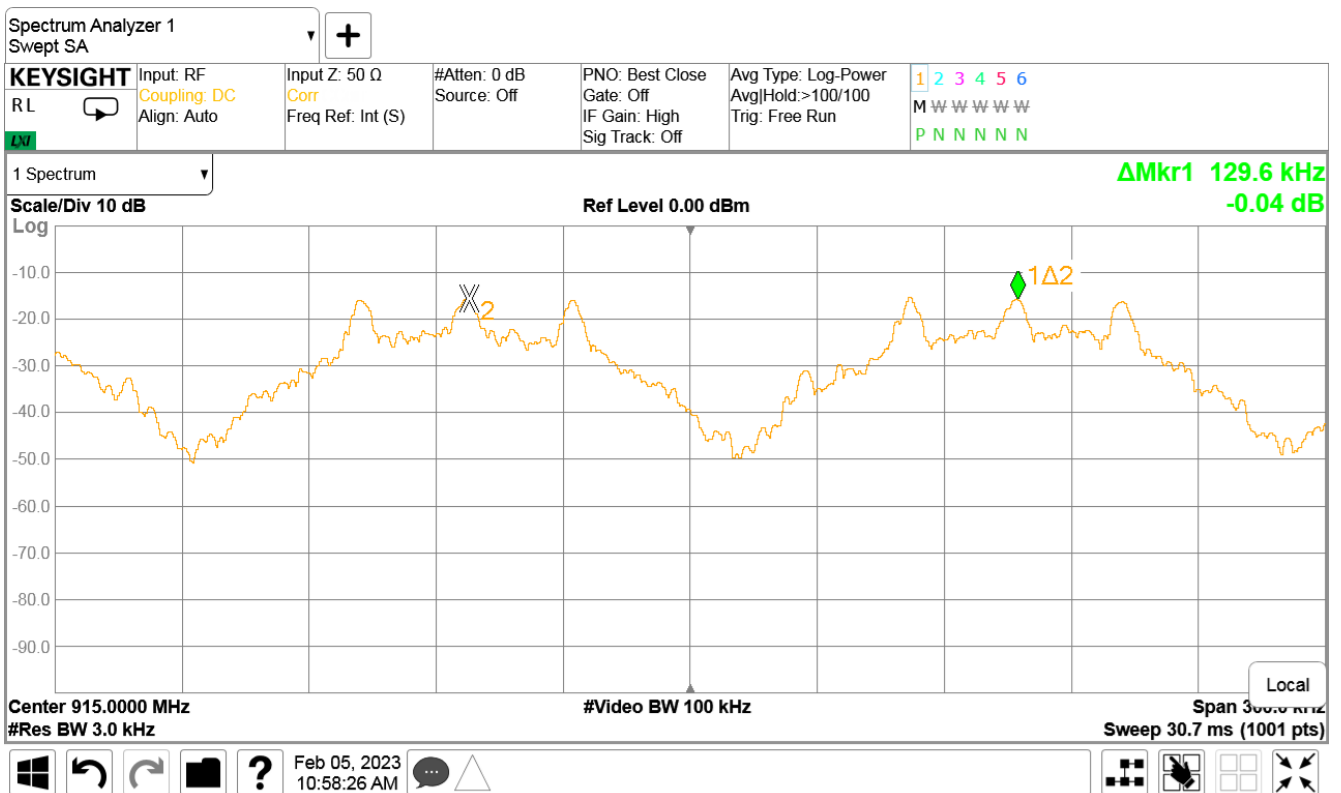



<b>Test specification:</b> Section 15.247(a)1, RSS-247 section 5.1(3), Number of hopping frequencies			
<b>Test procedure:</b> ANSI C63.10, section 7.8.3			
<b>Test mode:</b> Compliance		<b>Verdict:</b> PASS	
<b>Date(s):</b> 05-Feb-23			
<b>Temperature:</b> 20 °C	<b>Relative Humidity:</b> 49 %	<b>Air Pressure:</b> 1008 hPa	<b>Power:</b> 3.7 VDC
<b>Remarks:</b>			

### 7.3 Number of hopping frequencies

#### 7.3.1 General

This test was performed to calculate the number of hopping frequencies used by the EUT. Specification test limits are given in Table 7.3.1.

Table 7.3.1 Minimum number of hopping frequencies

Assigned frequency range, MHz	Number of hopping frequencies
902.0 – 928.0	50 (if the 20 dB bandwidth is less than 250 kHz) 25 (if the 20 dB bandwidth is 250 kHz or greater)
2400.0 – 2483.5	15
5725.0 – 5850.0	75

#### 7.3.2 Test procedure

7.3.2.1 The EUT was set up as shown in Figure 7.3.1, energized with frequency hopping function enabled and its proper operation was checked.

7.3.2.2 Initially the spectrum analyzer span was set equal to frequency band of operation and the resolution bandwidth was set wider than 1 % of the frequency span. If the separate hopping channels were not clearly resolved the frequency band of operation was broken to sections and the resolution bandwidth was set wider than 1 % of the frequency span of each section.

7.3.2.3 The spectrum analyzer was set in max hold mode and allowed trace to stabilize.

7.3.2.4 The number of frequency hopping channels was calculated as provided in Table 7.3.2 and associated plots.

Figure 7.3.1 Hopping frequencies test setup





<b>Test specification:</b> Section 15.247(a)1, RSS-247 section 5.1(3), Number of hopping frequencies			
<b>Test procedure:</b> ANSI C63.10, section 7.8.3			
<b>Test mode:</b> Compliance		<b>Verdict:</b> PASS	
<b>Date(s):</b> 05-Feb-23			
<b>Temperature:</b> 20 °C	<b>Relative Humidity:</b> 49 %	<b>Air Pressure:</b> 1008 hPa	<b>Power:</b> 3.7 VDC
<b>Remarks:</b>			

Table 7.3.2 Hopping frequencies test results

ASSIGNED FREQUENCY: 902-928 MHz  
 MODULATION: GFSK  
 BIT RATE: 50 kbps  
 DETECTOR USED: Peak  
 RESOLUTION BANDWIDTH: ≥ 1% of the span  
 VIDEO BANDWIDTH: ≥ RBW  
 FREQUENCY HOPPING: Enabled

Number of hopping frequencies	Minimum number of hopping frequencies	Margin*	Verdict
50	50	0	Pass

\* - Margin = Number of hopping frequencies – Minimum number of hopping frequencies.

Reference numbers of test equipment used

HL 5376	HL 4136	HL 3901					
---------	---------	---------	--	--	--	--	--

Full description is given in Appendix A.



HERMON LABORATORIES

<b>Test specification:</b> Section 15.247(a)1, RSS-247 section 5.1(3), Number of hopping frequencies			
<b>Test procedure:</b> ANSI C63.10, section 7.8.3			
<b>Test mode:</b> Compliance		<b>Verdict:</b> PASS	
<b>Date(s):</b> 05-Feb-23			
<b>Temperature:</b> 20 °C	<b>Relative Humidity:</b> 49 %	<b>Air Pressure:</b> 1008 hPa	<b>Power:</b> 3.7 VDC
<b>Remarks:</b>			

Plot 7.3.1 Number of hopping frequencies

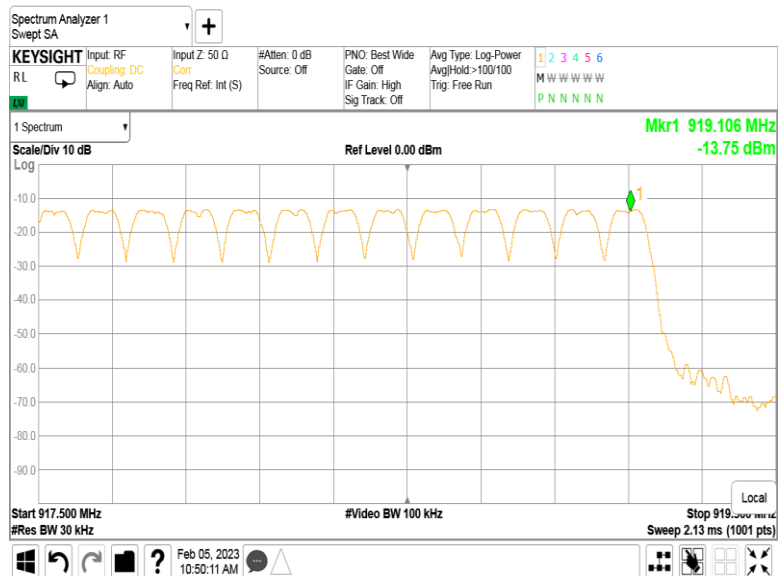
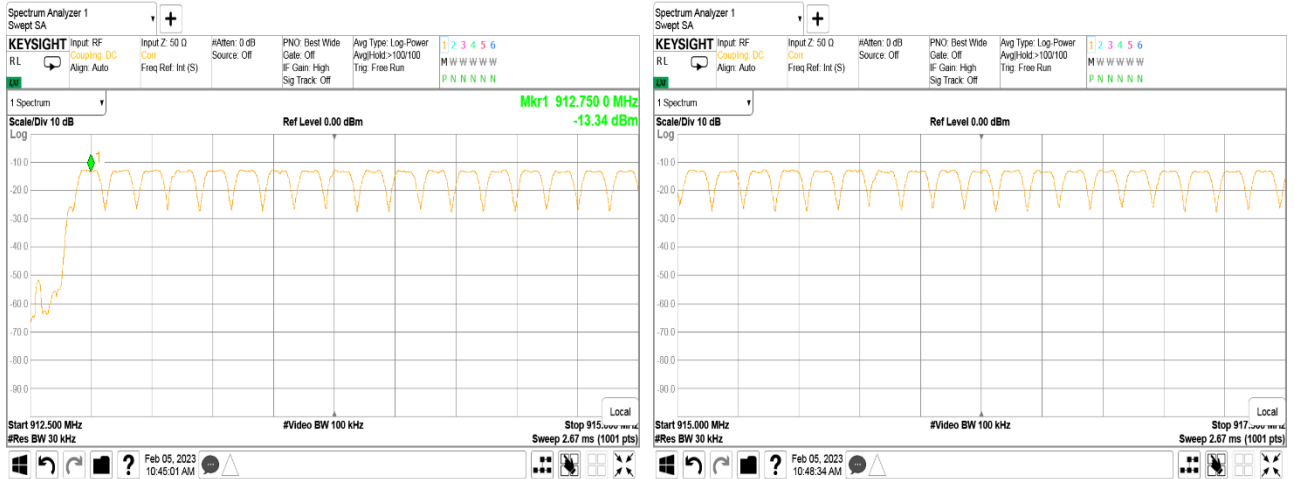



<b>Test specification:</b> Section 15.247(a)1, RSS-247 section 5.1(3), Average time of occupancy			
<b>Test procedure:</b> ANSI C63.10, section 7.8.4			
<b>Test mode:</b> Compliance		<b>Verdict:</b> PASS	
<b>Date(s):</b> 09-Feb-23			
<b>Temperature:</b> 24 °C	<b>Relative Humidity:</b> 54 %	<b>Air Pressure:</b> 1012 hPa	<b>Power:</b> 3.7 VDC
<b>Remarks:</b>			

## 7.4 Average time of occupancy

### 7.4.1 General

This test was performed to calculate the average time of occupancy (dwell time) on any frequency channel of the EUT. Specification test limits are given in Table 7.4.1.

Table 7.4.1 Average time of occupancy limits

Assigned frequency range, MHz	Maximum average time of occupancy, s	Investigated period, s	Number of hopping frequencies
902.0 – 928.0	0.4	20.0	≥ 50
902.0 – 928.0	0.4	10.0	< 50
2400.0 – 2483.5	0.4	0.4 × N	N (≥ 15)
5725.0 – 5850.0	0.4	30.0	≥ 75

### 7.4.2 Test procedure

- 7.4.2.1 The EUT was set up as shown in Figure 7.4.1, energized with frequency hopping function enabled and its proper operation was checked.
- 7.4.2.2 The spectrum analyzer span was set to zero centered on a hopping channel.
- 7.4.2.3 The single transmission duration and period were measured with oscilloscope.
- 7.4.2.4 The average time of occupancy was calculated as the single transmission time multiplied by the investigated period and divided by the single transmission period.
- 7.4.2.5 The test was repeated at each data rate and modulation type as provided in Table 7.4.2 and associated plots.

Figure 7.4.1 Average time of occupancy test setup

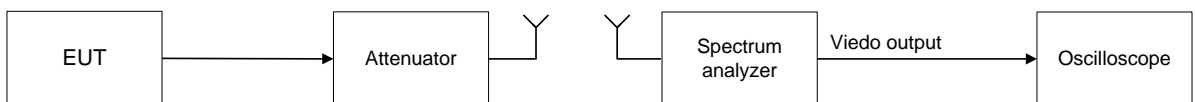



<b>Test specification:</b> Section 15.247(a)1, RSS-247 section 5.1(3), Average time of occupancy			
<b>Test procedure:</b> ANSI C63.10, section 7.8.4			
<b>Test mode:</b> Compliance		<b>Verdict:</b> PASS	
<b>Date(s):</b> 09-Feb-23			
<b>Temperature:</b> 24 °C	<b>Relative Humidity:</b> 54 %	<b>Air Pressure:</b> 1012 hPa	<b>Power:</b> 3.7 VDC
<b>Remarks:</b>			

Table 7.4.2 Average time of occupancy test results

ASSIGNED FREQUENCY: 902 – 928 MHz  
 MODULATION: GFSK  
 DETECTOR USED: Peak  
 RESOLUTION BANDWIDTH: 1 MHz  
 VIDEO BANDWIDTH: 3 MHz  
 NUMBER OF HOPPING FREQUENCIES: 50  
 INVESTIGATED PERIOD: 20 s  
 FREQUENCY HOPPING: Enabled

Carrier frequency, MHz	Single transmission duration, ms	Single transmission period, s	Average time of occupancy*, ms	Bit rate, kbps	Symbol rate, Msymbol/s	Limit, s	Margin, s**	Verdict
915.0	5.0	256	0.00025	50	NA	0.4	-0.3999	Pass

\* - Average time of occupancy = (Single transmission duration × Investigated period) / (Single transmission period × number of hopping channels).

\*\* - Margin = Average time of occupancy – specification limit.

Reference numbers of test equipment used

HL 3901	HL 4136	HL 5376	HL 5409			
---------	---------	---------	---------	--	--	--

Full description is given in Appendix A.

Plot 7.4.1 Single transmission duration

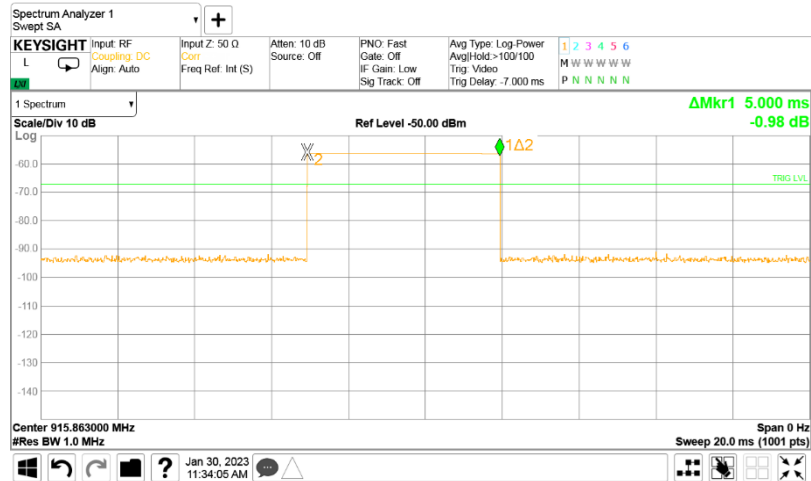





HERMON LABORATORIES

<b>Test specification:</b> Section 15.247(a)1, RSS-247 section 5.1(3), Average time of occupancy			
<b>Test procedure:</b> ANSI C63.10, section 7.8.4			
<b>Test mode:</b> Compliance		<b>Verdict:</b> PASS	
<b>Date(s):</b> 09-Feb-23			
<b>Temperature:</b> 24 °C	<b>Relative Humidity:</b> 54 %	<b>Air Pressure:</b> 1012 hPa	<b>Power:</b> 3.7 VDC
<b>Remarks:</b>			

Plot 7.4.2 Single transmission period

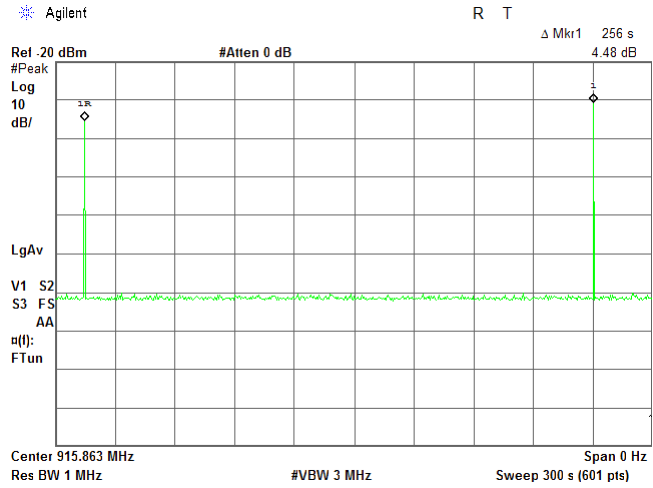



<b>Test specification:</b> Section 15.247(b), RSS-247 section 5.4(1), Peak output power			
<b>Test procedure:</b> ANSI C63.10, section 7.8.5			
<b>Test mode:</b> Compliance		<b>Verdict:</b> PASS	
<b>Date(s):</b> 05-Feb-23			
<b>Temperature:</b> 21 °C	<b>Relative Humidity:</b> 54 %	<b>Air Pressure:</b> 1012 hPa	<b>Power:</b> 3.7 VDC
<b>Remarks:</b>			

## 7.5 Peak output power

### 7.5.1 General

This test was performed to measure the maximum peak output power radiated by transmitter. Specification test limits are given in Table 7.5.1.

Table 7.5.1 Peak output power limits

Assigned frequency range, MHz	Peak output power*		Equivalent field strength limit @ 3m, dB(μV/m)*	Maximum antenna gain, dBi
	W	dBm		
902.0 – 928.0	0.25 (<50 hopping channels)	24.0(<50 hopping channels)	125.2 (<50 hopping channels)	6.0*
	1.0 (≥50 hopping channels)	30.0 (≥50 hopping channels)	131.2 (≥50 hopping channels)	
2400.0 – 2483.5	0.125 (<75 hopping channels)	21.0(<75 hopping channels)	122.2 (<75 hopping channels)	
	1.0 (≥75 hopping channels)	30.0 (≥75 hopping channels)	131.2 (≥75 hopping channels)	
5725.0 – 5850.0	1.0	30.0	131.2	

\*- Equivalent field strength limit was calculated from the peak output power as follows:  $E = \sqrt{30 \times P \times G} / r$ , where P is peak output power in Watts, r is antenna to EUT distance in meters and G is transmitter antenna gain in dBi.

\*\* - The limit is provided in terms of conducted RF power at the antenna connector. If transmitting antennas of directional gain greater than 6 dBi are used, the peak output power limit shall be reduced below the stated value as follows:

- by 1 dB for every 3 dB that the directional gain of antenna exceeds 6 dBi for fixed point-to-point transmitters operate in 2400-2483.5 MHz band;
- without any corresponding reduction for fixed point-to-point transmitters operate in 5725-5850 MHz band;
- by the amount in dB that the directional gain of antenna exceeds 6 dBi for the rest of transmitters.

### 7.5.2 Test procedure

7.5.2.1 The EUT was set up as shown in Figure 7.5.1, energized and its proper operation was checked.

7.5.2.2 The EUT was adjusted to produce maximum available to end user RF output power.

7.5.2.3 The frequency span of spectrum analyzer was set approximately 5 times wider than 20 dB bandwidth of the EUT and the resolution bandwidth was set wider than 20 dB bandwidth of the EUT. To find maximum radiation the turntable was rotated 360° and the measuring antenna height was swept in both vertical and horizontal polarizations.

7.5.2.4 The maximum field strength of the EUT carrier frequency was measured as provided in Table 7.5.2 and associated plots.

7.5.2.5 The maximum peak output power was calculated from the field strength of carrier as follows:

$$P = (E \times d)^2 / (30 \times G),$$

where P is the peak output power in W, E is the field strength in V/m, d is the test distance and G is the transmitter numeric antenna gain over an isotropic radiator.

The above equation was converted in logarithmic units for 3 m test distance:

$$\text{Peak output power in dBm} = \text{Field strength in dB}(\mu\text{V/m}) - \text{Transmitter antenna gain in dBi} - 95.2 \text{ dB}$$

7.5.2.6 The worst test results (the lowest margins) were recorded in Table 7.5.2.



<b>Test specification:</b> Section 15.247(b), RSS-247 section 5.4(1), Peak output power			
<b>Test procedure:</b> ANSI C63.10, section 7.8.5			
<b>Test mode:</b> Compliance		<b>Verdict:</b> PASS	
<b>Date(s):</b> 05-Feb-23			
<b>Temperature:</b> 21 °C	<b>Relative Humidity:</b> 54 %	<b>Air Pressure:</b> 1012 hPa	<b>Power:</b> 3.7 VDC
<b>Remarks:</b>			

Figure 7.5.1 Setup for carrier field strength measurements

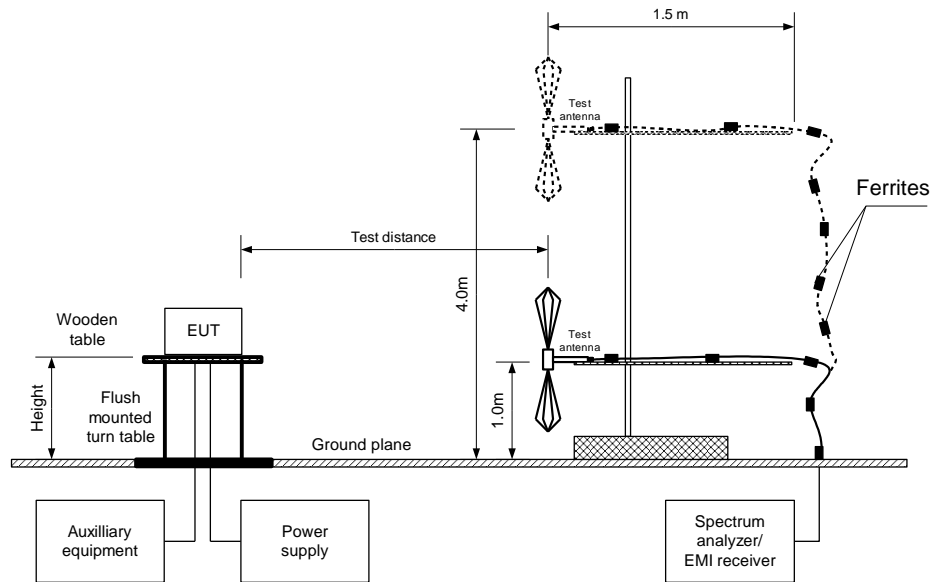



<b>Test specification:</b> Section 15.247(b), RSS-247 section 5.4(1), Peak output power			
<b>Test procedure:</b> ANSI C63.10, section 7.8.5			
<b>Test mode:</b> Compliance		<b>Verdict:</b> PASS	
<b>Date(s):</b> 05-Feb-23			
<b>Temperature:</b> 21 °C	<b>Relative Humidity:</b> 54 %	<b>Air Pressure:</b> 1012 hPa	<b>Power:</b> 3.7 VDC
<b>Remarks:</b>			

Table 7.5.2 Peak output power test results

ASSIGNED FREQUENCY: 902-928MHz  
TEST DISTANCE: 3 m  
TEST SITE: Semi anechoic chamber  
EUT HEIGHT: 0.8 m  
DETECTOR USED: Peak  
TEST ANTENNA TYPE: Biconilog (30 MHz – 1000 MHz)  
Double ridged guide (above 1000 MHz)  
MODULATION: GFSK  
MODULATING SIGNAL: PRBS  
BIT RATE: 50 kbps  
TRANSMITTER OUTPUT POWER SETTINGS: Maximum  
DETECTOR USED: Peak  
RESOLUTION BANDWIDTH: 120 kHz  
VIDEO BANDWIDTH: 300 kHz  
FREQUENCY HOPPING: Disabled

Frequency, MHz	Field strength, dB(μV/m)	Antenna polarization	Antenna height, m	Azimuth, degrees*	EUT antenna gain, dBi	Peak output power, dBm**	Limit, dBm	Margin, dB***	Verdict
912.765	106.3	Horizontal	1.0	-118	-2	13.1	30	-16.9	Pass
915.84	105.2	Horizontal	1.0	-119	-2	12.0	30	-18.0	Pass
919.134	105.3	Horizontal	1.0	-118	-2	12.1	30	-17.9	Pass

\*- EUT front panel refer to 0 degrees position of turntable.

\*\* - Peak output power was calculated from the field strength of carrier as follows:  $P = (E \times d)^2 / (30 \times G)$ , where P is the peak output power in W, E is the field strength in V/m, d is the test distance in meters and G is the transmitter numeric antenna gain over an isotropic radiator. The above equation was converted in logarithmic units for 3 m test distance: *Peak output power in dBm = Field strength in dB(μV/m) - Transmitter antenna gain in dBi - 95.2 dB*

\*\*\* - Margin = Peak output power – specification limit.

#### Reference numbers of test equipment used

HL 3903	HL 5288	HL 5902	HL 7585				
---------	---------	---------	---------	--	--	--	--

Full description is given in Appendix A.



<b>Test specification: Section 15.247(b), RSS-247 section 5.4(1), Peak output power</b>			
<b>Test procedure:</b> ANSI C63.10, section 7.8.5			
<b>Test mode:</b> Compliance		<b>Verdict:</b> PASS	
<b>Date(s):</b> 05-Feb-23			
<b>Temperature:</b> 21 °C	<b>Relative Humidity:</b> 54 %	<b>Air Pressure:</b> 1012 hPa	<b>Power:</b> 3.7 VDC
<b>Remarks:</b>			

Plot 7.5.1 Field strength of carrier at low frequency

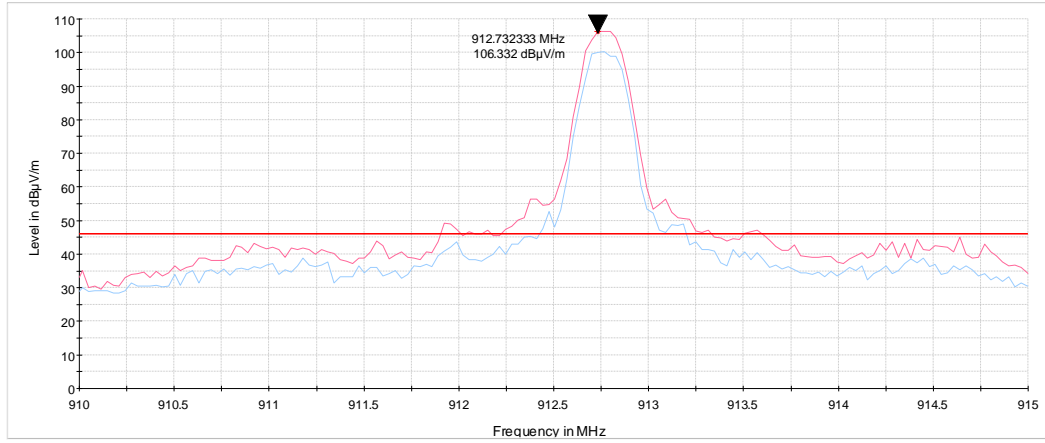

Plot 7.5.2 Field strength of carrier at mid frequency

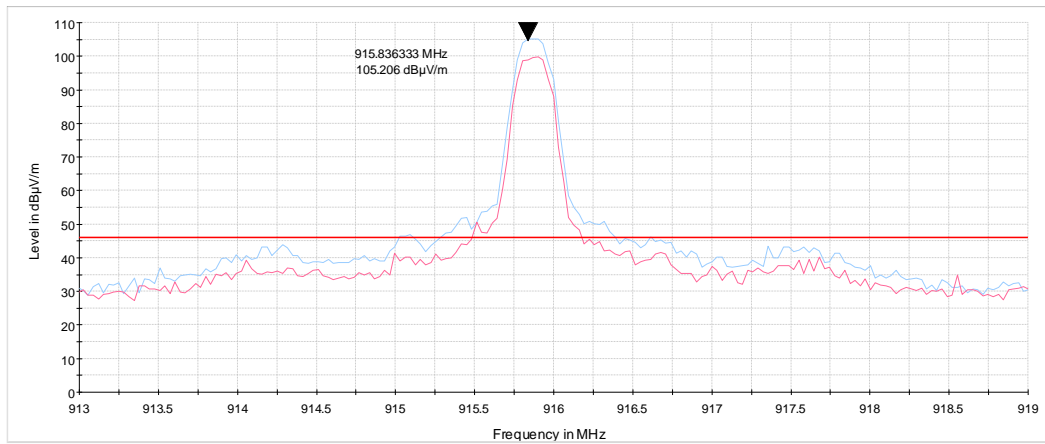



<b>Test specification:</b> Section 15.247(b), RSS-247 section 5.4(1), Peak output power			
<b>Test procedure:</b> ANSI C63.10, section 7.8.5			
<b>Test mode:</b> Compliance		<b>Verdict:</b> PASS	
<b>Date(s):</b> 05-Feb-23			
<b>Temperature:</b> 21 °C	<b>Relative Humidity:</b> 54 %	<b>Air Pressure:</b> 1012 hPa	<b>Power:</b> 3.7 VDC
<b>Remarks:</b>			

Plot 7.5.3 Field strength of carrier at high frequency

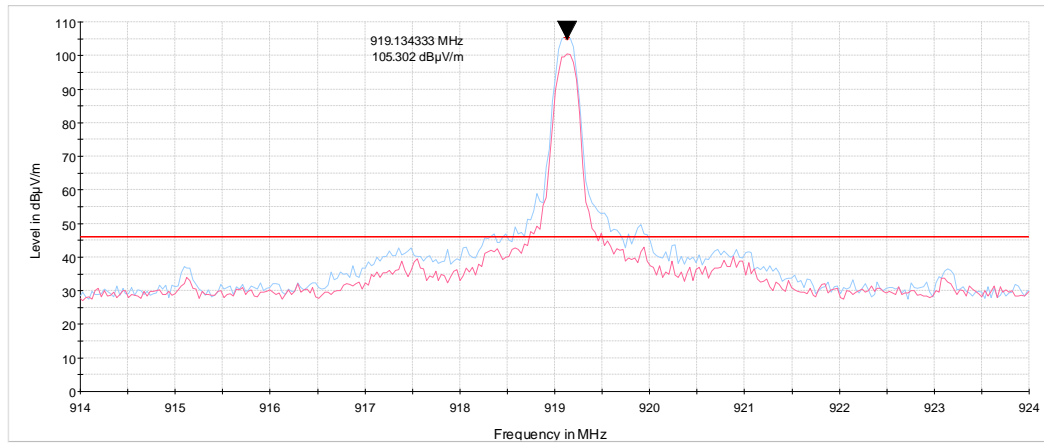



<b>Test specification:</b> Section 15.247(d), RSS-247 section 5.5, Radiated spurious emissions			
<b>Test procedure:</b> ANSI C63.10, sections 6.5, 6.6			
<b>Test mode:</b> Compliance		<b>Verdict:</b> PASS	
<b>Date(s):</b> 02-Feb-23			
<b>Temperature:</b> 21 °C	<b>Relative Humidity:</b> 49 %	<b>Air Pressure:</b> 1007 hPa	<b>Power:</b> 3.7 VDC
<b>Remarks:</b>			

## 7.6 Field strength of spurious emissions

### 7.6.1 General

This test was performed to measure field strength of spurious emissions from the EUT. Specification test limits are given in Table 7.6.1.

Table 7.6.1 Radiated spurious emissions limits

Frequency, MHz	Field strength at 3 m within restricted bands, dB(μV/m) <sup>***</sup>			Attenuation of field strength of spurious versus carrier outside restricted bands, dBc <sup>***</sup>
	Peak	Quasi Peak	Average	
0.009 – 0.090	148.5 – 128.5	NA	128.5 – 108.5 <sup>**</sup>	20.0
0.090 – 0.110	NA	108.5 – 106.8 <sup>**</sup>	NA	
0.110 – 0.490	126.8 – 113.8	NA	106.8 – 93.8 <sup>**</sup>	
0.490 – 1.705	NA	73.8 – 63.0 <sup>**</sup>	NA	
1.705 – 30.0*		69.5		
30 – 88		40.0		
88 – 216		43.5		
216 – 960		46.0		
960 - 1000		54.0		
1000 – 10 <sup>th</sup> harmonic	74.0	NA	54.0	

\*- The limit for 3 m test distance was calculated using the inverse square distance extrapolation factor as follows:  

$$\text{Lim}_{S_2} = \text{Lim}_{S_1} + 40 \log (S_1/S_2),$$

where  $S_1$  and  $S_2$  – standard defined and test distance respectively in meters.

\*\* - The limit decreases linearly with the logarithm of frequency.

\*\*\* - The field strength limits applied from the lowest radio frequency generated in the device, without going below 9 kHz up to the tenth harmonic of the highest fundamental frequency.

### 7.6.2 Test procedure for spurious emission field strength measurements in 9 kHz to 30 MHz band

7.6.2.1 The EUT was set up as shown in Figure 7.6.1, energized and the performance check was conducted.

7.6.2.2 The specified frequency range was investigated with antenna connected to spectrum analyzer/ EMI receiver. To find maximum radiation the turntable was rotated 360° and the measuring antenna was rotated around its vertical axis.

7.6.2.3 The worst test results (the lowest margins) were recorded and shown in the associated plots.

### 7.6.3 Test procedure for spurious emission field strength measurements above 30 MHz

7.6.3.1 The EUT was set up as shown in Figure 7.6.2, Figure 1.1.3, energized and the performance check was conducted.

7.6.3.2 The specified frequency range was investigated with antenna connected to spectrum analyzer/ EMI receiver. To find maximum radiation the turntable was rotated 360°, the measuring antenna height was changed from 1 to 4 m, its polarization was switched from vertical to horizontal.

7.6.3.3 The worst test results (the lowest margins) were recorded and shown in the associated plots.



<b>Test specification: Section 15.247(d), RSS-247 section 5.5, Radiated spurious emissions</b>			
<b>Test procedure:</b> ANSI C63.10, sections 6.5, 6.6			
<b>Test mode:</b> Compliance		<b>Verdict: PASS</b>	
<b>Date(s):</b> 02-Feb-23			
<b>Temperature:</b> 21 °C	<b>Relative Humidity:</b> 49 %	<b>Air Pressure:</b> 1007 hPa	<b>Power:</b> 3.7 VDC
<b>Remarks:</b>			

Figure 7.6.1 Setup for spurious emission field strength measurements below 30 MHz

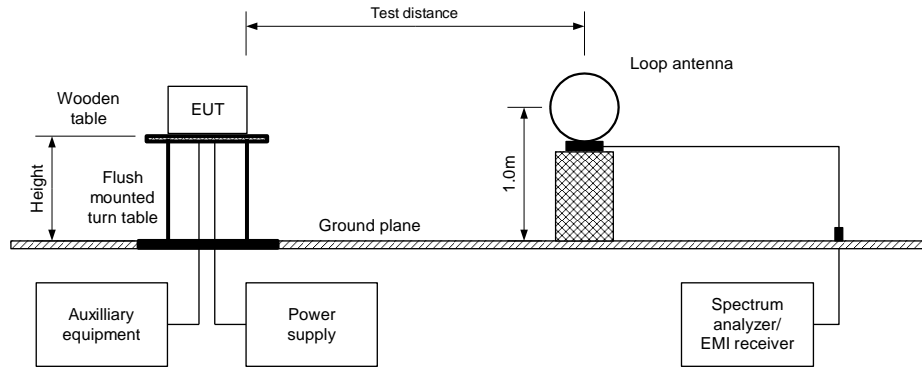
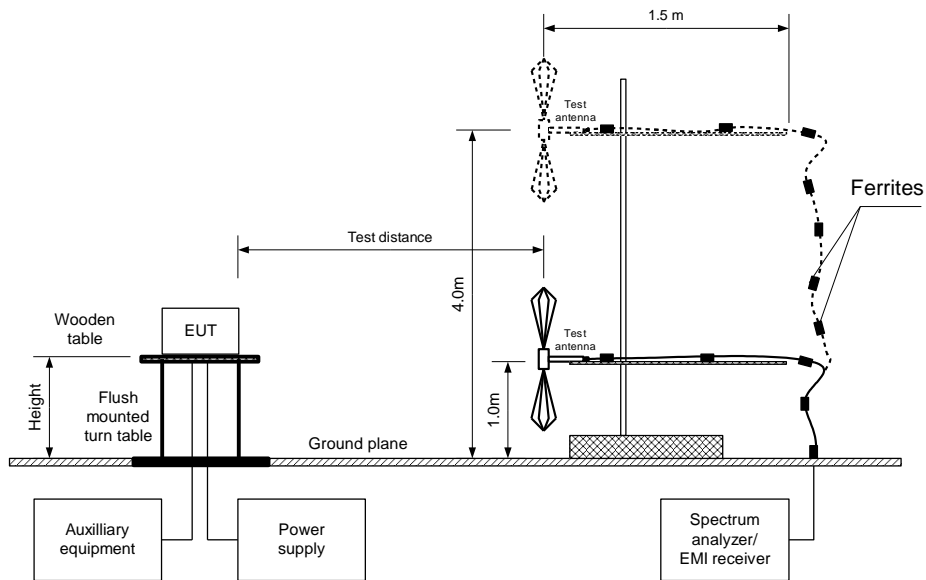

Figure 7.6.2 Setup for spurious emission field strength measurements from 30 to 1000 MHz







<b>Test specification: Section 15.247(d), RSS-247 section 5.5, Radiated spurious emissions</b>			
Test procedure: ANSI C63.10, sections 6.5, 6.6		Verdict: PASS	
Test mode: Compliance		Date(s): 02-Feb-23	
Temperature: 21 °C	Relative Humidity: 49 %	Air Pressure: 1007 hPa	Power: 3.7 VDC
Remarks:			

Figure 7.6.3 Setup for spurious emission field strength measurements above 1000 MHz

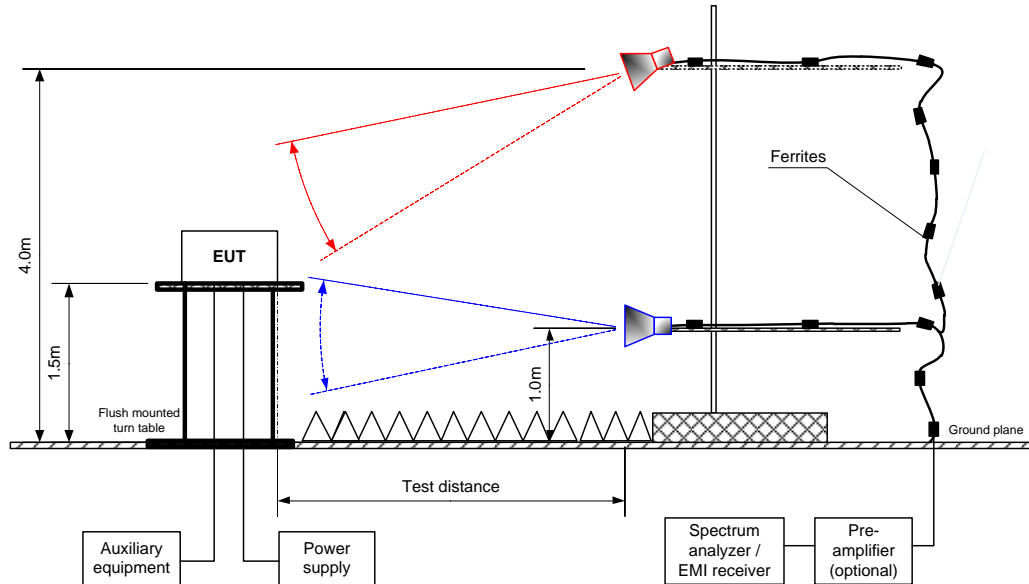



<b>Test specification: Section 15.247(d), RSS-247 section 5.5, Radiated spurious emissions</b>			
<b>Test procedure:</b> ANSI C63.10, sections 6.5, 6.6			
<b>Test mode:</b> Compliance		<b>Verdict: PASS</b>	
<b>Date(s):</b> 02-Feb-23			
<b>Temperature:</b> 21 °C	<b>Relative Humidity:</b> 49 %	<b>Air Pressure:</b> 1007 hPa	<b>Power:</b> 3.7 VDC
<b>Remarks:</b>			

**Table 7.6.2 Field strength of emissions outside restricted bands**

ASSIGNED FREQUENCY: 902-928 MHz  
 INVESTIGATED FREQUENCY RANGE: 0.009 -10000 MHz  
 TEST DISTANCE: 3 m  
 MODULATION: GFSK  
 BIT RATE: 50 kbps  
 DUTY CYCLE: 100 %  
 TRANSMITTER OUTPUT POWER SETTINGS: Maximum  
 DETECTOR USED: Peak  
 RESOLUTION BANDWIDTH: 100 kHz  
 VIDEO BANDWIDTH: 300 kHz  
 TEST ANTENNA TYPE: Active loop (9 kHz – 30 MHz)  
 Biconilog (30 MHz – 1000 MHz)  
 Double ridged guide (above 1000 MHz)  
 FREQUENCY HOPPING: Disabled

Frequency, MHz	Field strength of spurious, dB(µV/m)	Antenna polarization	Antenna height, m	Azimuth, degrees*	Field strength of carrier, dB(µV/m)	Attenuation below carrier, dBc	Limit, dBc	Margin, dB**	Verdict
<b>Low carrier frequency 912.750 MHz</b>									
6389.25	58.3	Horizontal	2.1	154	106.3	48	20	28	Pass
<b>Mid carrier frequency 915.863 MHz</b>									
1831.726	41.3	Horizontal	2.1	-145	105.2	63.9	20.0	43.9	Pass
6411.041	56.5	Horizontal	2.2	173		48.7		28.7	
<b>High carrier frequency 919.106 MHz</b>									
1838.212	39.9	Horizontal	2.3	180	105.1	65.2	20	45.2	Pass
6433.742	49.5	Vertical	1.9	180		55.6		35.6	

\*- EUT front panel refers to 0 degrees position of turntable.  
 \*\*- Margin = Attenuation below carrier – specification limit.

**Table 7.6.3 Field strength of spurious emissions below 1 GHz within restricted bands**

ASSIGNED FREQUENCY: 902-928 MHz  
 INVESTIGATED FREQUENCY RANGE: 0.009 – 1000 MHz  
 TEST DISTANCE: 3 m  
 MODULATION: GFSK  
 BIT RATE: 50 kbps  
 DUTY CYCLE: 100 %  
 TRANSMITTER OUTPUT POWER SETTINGS: Maximum  
 RESOLUTION BANDWIDTH: 0.2 kHz (9 kHz – 150 kHz)  
 9.0 kHz (150 kHz – 30 MHz)  
 120 kHz (30 MHz – 1000 MHz)  
 VIDEO BANDWIDTH: > Resolution bandwidth  
 TEST ANTENNA TYPE: Active loop (9 kHz – 30 MHz)  
 Biconilog (30 MHz – 1000 MHz)  
 FREQUENCY HOPPING: Disabled

Frequency, MHz	Peak emission, dB(µV/m)	Quasi-peak			Antenna polarization	Antenna height, m	Turn-table position**, degrees	Verdict
		Measured emission, dB(µV/m)	Limit, dB(µV/m)	Margin, dB*				
<b>Low ,Mid, High carrier frequency</b>								Pass
No spurious emissions were found								

\*- Margin = Measured emission - specification limit.  
 \*\*- EUT front panel refer to 0 degrees position of turntable.



<b>Test specification:</b> Section 15.247(d), RSS-247 section 5.5, Radiated spurious emissions			
<b>Test procedure:</b> ANSI C63.10, sections 6.5, 6.6			
<b>Test mode:</b> Compliance		<b>Verdict:</b> PASS	
<b>Date(s):</b> 02-Feb-23			
<b>Temperature:</b> 21 °C	<b>Relative Humidity:</b> 49 %	<b>Air Pressure:</b> 1007 hPa	<b>Power:</b> 3.7 VDC
<b>Remarks:</b>			

**Table 7.6.4 Field strength of spurious emissions above 1 GHz within restricted bands**

ASSIGNED FREQUENCY: 902-928 MHz  
 INVESTIGATED FREQUENCY RANGE: 1000 – 10000 MHz  
 TEST DISTANCE: 3 m  
 MODULATION: GFSK  
 BIT RATE: 50 kbps  
 DUTY CYCLE: 100 %  
 DETECTOR USED: Peak  
 RESOLUTION BANDWIDTH: 1000 kHz  
 TEST ANTENNA TYPE: Double ridged guide  
 FREQUENCY HOPPING: Disabled

Frequency, MHz	Antenna		Azimuth, degrees*	Peak field strength			Average field strength				Verdict
	Polarization	Height, m		Measured, dB(µV/m)	Limit, dB(µV/m)	Margin, dB**	Measured, dB(µV/m)	Calculated, dB(µV/m)	Limit, dB(µV/m)	Margin, dB***	
<b>Low carrier frequency 912.750 MHz</b>											
2738.25	Vertical	1.7	-136	47.9	74	-26.1	47.9	21.9	54	-32.1	Pass
4563.75	Vertical	1.9	-117	59.5	74	-14.5	59.5	33.5	54	-20.5	
<b>Mid carrier frequency 915.863 MHz</b>											
2747.589	Vertical	2.3	-135	47.0	74	-27.0	47.0	21	54	-33	Pass
4579.315	Vertical	2.4	-107	60.0	74	-14.0	60.0	34	54	-20	
<b>High carrier frequency 919.106 MHz</b>											
2757.318	Vertical	1.9	-145	47.0	74	-27.0	47.0	21	54	-33	Pass
3676.424	Vertical	2.3	-136	44.7	74	-29.3	44.7	18.7	54	-35.3	
4595.530	Vertical	1.9	-163	59.1	74	-14.9	59.1	33.1	54	-20.9	

\*- EUT front panel refers to 0 degrees position of turntable.  
 \*\*- Margin = Measured field strength - specification limit.  
 \*\*\*- Margin = Calculated field strength - specification limit,  
 where Calculated field strength = Measured field strength + average factor.

**Table 7.6.5 Average factor calculation**

Transmission pulse		Transmission burst		Transmission train duration, ms	Average factor, dB
Duration, ms	Period, s	Duration, ms	Period, ms		
5	256	NA	NA	NA	-26

\*- Average factor was calculated as follows

for pulse train shorter than 100 ms:

$$Average\ factor = 20 \times \log_{10} \left( \frac{Pulse\ duration}{Pulse\ period} \times \frac{Burst\ duration}{Train\ duration} \times Number\ of\ bursts\ within\ pulse\ train \right)$$

for pulse train longer than 100 ms:

$$Average\ factor = 20 \times \log_{10} \left( \frac{Pulse\ duration}{Pulse\ period} \times \frac{Burst\ duration}{100ms} \times Number\ of\ bursts\ within\ 100ms \right)$$



<b>Test specification:</b> Section 15.247(d), RSS-247 section 5.5, Radiated spurious emissions			
<b>Test procedure:</b> ANSI C63.10, sections 6.5, 6.6			
<b>Test mode:</b> Compliance		<b>Verdict:</b> PASS	
<b>Date(s):</b> 02-Feb-23			
<b>Temperature:</b> 21 °C	<b>Relative Humidity:</b> 49 %	<b>Air Pressure:</b> 1007 hPa	<b>Power:</b> 3.7 VDC
<b>Remarks:</b>			

Table 7.6.6 Restricted bands according to FCC section 15.205

MHz	MHz	MHz	MHz	MHz	GHz
0.09 - 0.11	8.37625 - 8.38675	73 - 74.6	399.9 - 410	2690 - 2900	10.6 - 12.7
0.495 - 0.505	8.41425 - 8.41475	74.8 - 75.2	608 - 614	3260 - 3267	13.25 - 13.4
2.1735 - 2.1905	12.29 - 12.293	108 - 121.94	960 - 1240	3332 - 3339	14.47 - 14.5
4.125 - 4.128	12.51975 - 12.52025	123 - 138	1300 - 1427	3345.8 - 3358	15.35 - 16.2
4.17725 - 4.17775	12.57675 - 12.57725	149.9 - 150.05	1435 - 1626.5	3600 - 4400	17.7 - 21.4
4.20725 - 4.20775	13.36 - 13.41	156.52475 - 156.52525	1645.5 - 1646.5	4500 - 5150	22.01 - 23.12
6.215 - 6.218	16.42 - 16.423	156.7 - 156.9	1660 - 1710	5350 - 5460	23.6 - 24
6.26775 - 6.26825	16.69475 - 16.69525	162.0125 - 167.17	1718.8 - 1722.2	7250 - 7750	31.2 - 31.8
6.31175 - 6.31225	16.80425 - 16.80475	167.72 - 173.2	2200 - 2300	8025 - 8500	36.43 - 36.5
8.291 - 8.294	25.5 - 25.67	240 - 285	2310 - 2390	9000 - 9200	Above 38.6
8.362 - 8.366	37.5 - 38.25	322 - 335.4	2483.5 - 2500	9300 - 9500	

Table 7.6.7 Restricted bands according to RSS-Gen

MHz	MHz	MHz	MHz	MHz	GHz
0.09 - 0.11	8.291 - 8.294	16.80425 - 16.80475	399.9 - 410	3260 - 3267	10.6 - 12.7
2.1735 - 2.1905	8.362 - 8.366	25.5 - 25.67	608 - 614	3332 - 3339	13.25 - 13.4
3.020 - 3.026	8.37625 - 8.38675	37.5 - 38.25	960 - 1427	3345.8 - 3358	14.47 - 14.5
4.125 - 4.128	8.41425 - 8.41475	73 - 74.6	1435 - 1626.5	3500 - 4400	15.35 - 16.2
4.17725 - 4.17775	12.29 - 12.293	74.8 - 75.2	1645.5 - 1646.5	4500 - 5150	17.7 - 21.4
4.20725 - 4.20775	12.51975 - 12.52025	108 - 138	1660 - 1710	5350 - 5460	22.01 - 23.12
5.677 - 5.683	12.57675 - 12.57725	156.52475 - 156.52525	1718.8 - 1722.2	7250 - 7750	23.6 - 24
6.215 - 6.218	13.36 - 13.41	156.7 - 156.9	2200 - 2300	8025 - 8500	31.2 - 31.8
6.26775 - 6.26825	16.42 - 16.423	240 - 285	2310 - 2390	9000 - 9200	36.43 - 36.5
6.31175 - 6.31225	16.69475 - 16.69525	322 - 335.4	2655 - 2900	9300 - 9500	Above 38.6

Reference numbers of test equipment used

HL 0446	HL 3903	HL 5288	HL 5902	HL 7585			
---------	---------	---------	---------	---------	--	--	--

Full description is given in Appendix A.



<b>Test specification:</b> Section 15.247(d), RSS-247 section 5.5, Radiated spurious emissions			
<b>Test procedure:</b> ANSI C63.10, sections 6.5, 6.6			
<b>Test mode:</b> Compliance		<b>Verdict:</b> PASS	
<b>Date(s):</b> 02-Feb-23			
<b>Temperature:</b> 21 °C	<b>Relative Humidity:</b> 49 %	<b>Air Pressure:</b> 1007 hPa	<b>Power:</b> 3.7 VDC
<b>Remarks:</b>			

**Plot 7.6.1 Radiated emission measurements from 9 kHz to 30 MHz at the low carrier frequency**

TEST SITE: Semi anechoic chamber  
TEST DISTANCE: 3 m

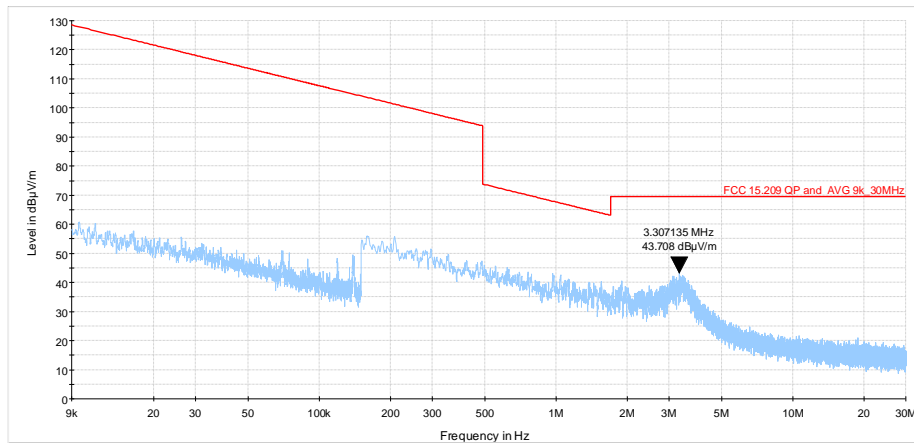

**Plot 7.6.2 Radiated emission measurements from 9 kHz to 30 MHz at the mid carrier frequency**

TEST SITE: Semi anechoic chamber  
TEST DISTANCE: 3 m

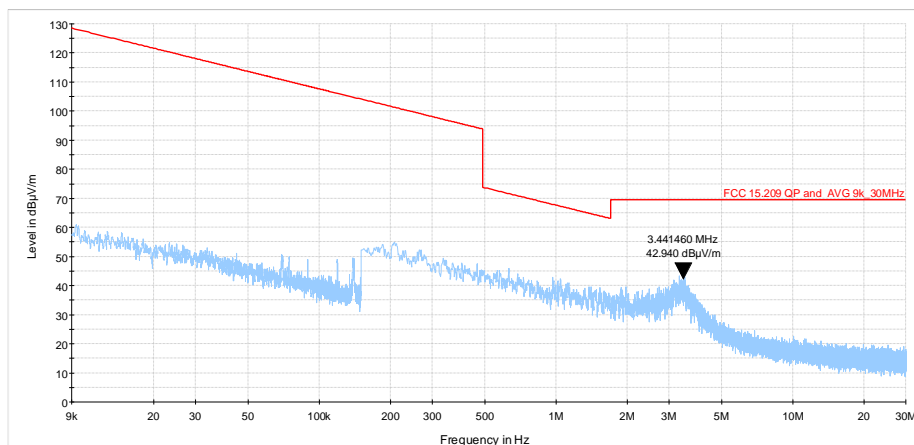



<b>Test specification: Section 15.247(d), RSS-247 section 5.5, Radiated spurious emissions</b>			
Test procedure: ANSI C63.10, sections 6.5, 6.6			
Test mode: Compliance		Verdict: PASS	
Date(s): 02-Feb-23			
Temperature: 21 °C	Relative Humidity: 49 %	Air Pressure: 1007 hPa	Power: 3.7 VDC
Remarks:			

Plot 7.6.3 Radiated emission measurements from 9 kHz to 30 MHz at the high carrier frequency

TEST SITE: Semi anechoic chamber  
TEST DISTANCE: 3 m

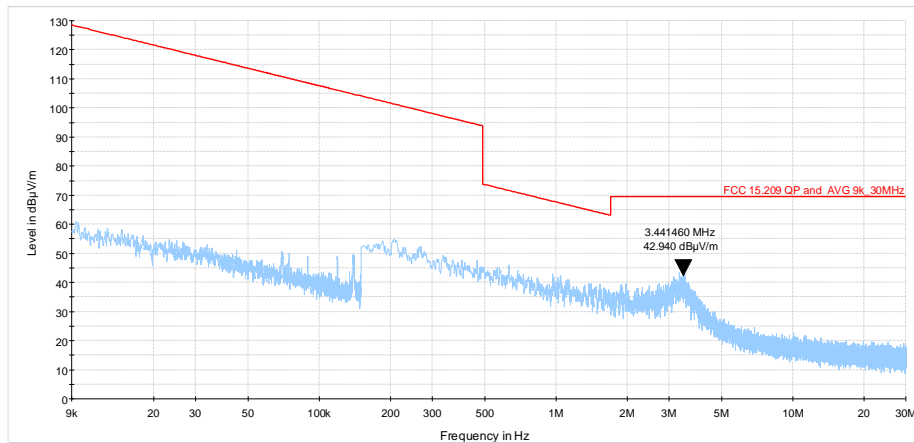

Plot 7.6.4 Radiated emission measurements from 30 to 1000 MHz at the low carrier frequency

TEST SITE: Semi anechoic chamber  
TEST DISTANCE: 3 m  
ANTENNA POLARIZATION: Vertical and Horizontal

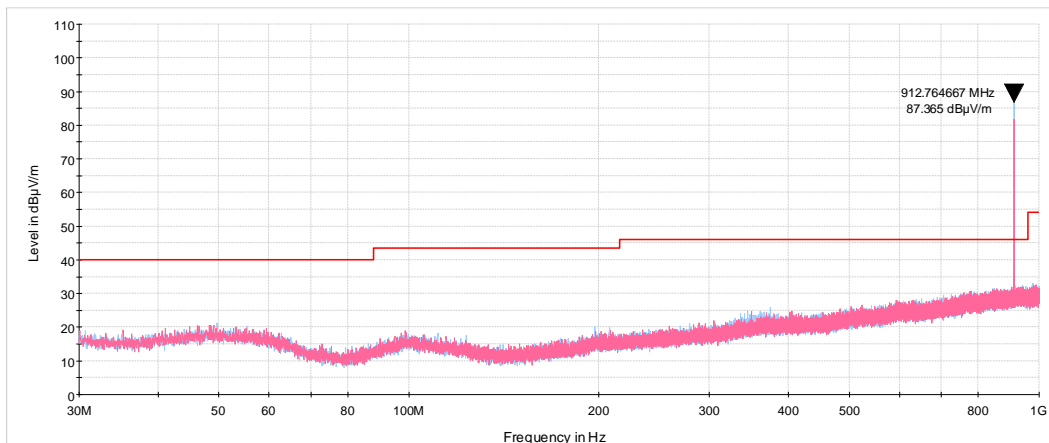



<b>Test specification:</b> Section 15.247(d), RSS-247 section 5.5, Radiated spurious emissions			
<b>Test procedure:</b> ANSI C63.10, sections 6.5, 6.6			
<b>Test mode:</b> Compliance		<b>Verdict:</b> PASS	
<b>Date(s):</b> 02-Feb-23			
<b>Temperature:</b> 21 °C	<b>Relative Humidity:</b> 49 %	<b>Air Pressure:</b> 1007 hPa	<b>Power:</b> 3.7 VDC
<b>Remarks:</b>			

**Plot 7.6.5 Radiated emission measurements from 30 to 1000 MHz at the mid carrier frequency**

TEST SITE: Semi anechoic chamber  
 TEST DISTANCE: 3 m  
 ANTENNA POLARIZATION: Vertical and Horizontal

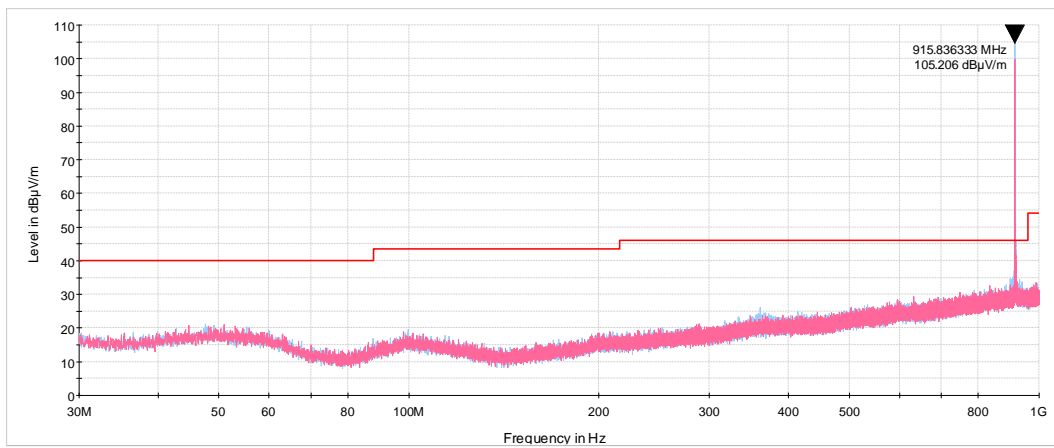

**Plot 7.6.6 Radiated emission measurements from 30 to 1000 MHz at the high carrier frequency**

TEST SITE: Semi anechoic chamber  
 TEST DISTANCE: 3 m  
 ANTENNA POLARIZATION: Vertical and Horizontal

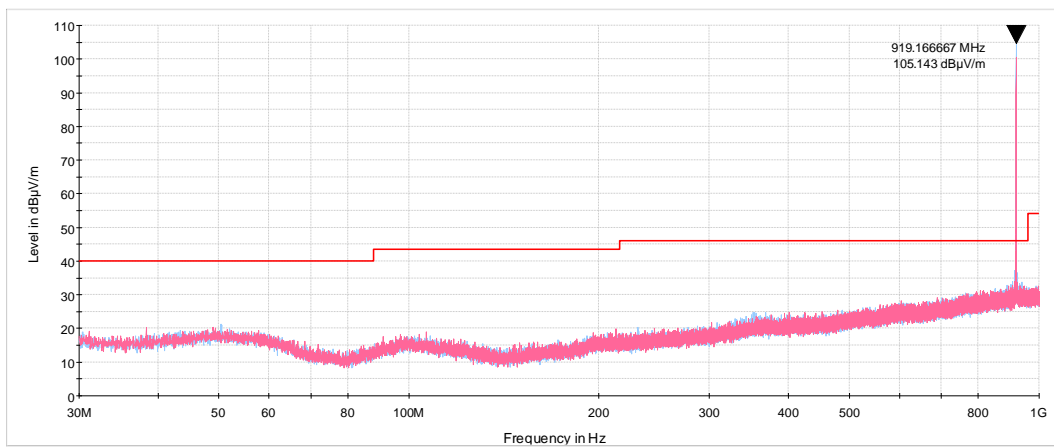



<b>Test specification: Section 15.247(d), RSS-247 section 5.5, Radiated spurious emissions</b>			
Test procedure: ANSI C63.10, sections 6.5, 6.6			
Test mode: Compliance		Verdict: PASS	
Date(s): 02-Feb-23			
Temperature: 21 °C	Relative Humidity: 49 %	Air Pressure: 1007 hPa	Power: 3.7 VDC
Remarks:			

Plot 7.6.7 Radiated emission measurements from 1000 to 9500 MHz at the low carrier frequency

TEST SITE: Semi anechoic chamber  
 TEST DISTANCE: 3 m  
 ANTENNA POLARIZATION: Vertical and Horizontal

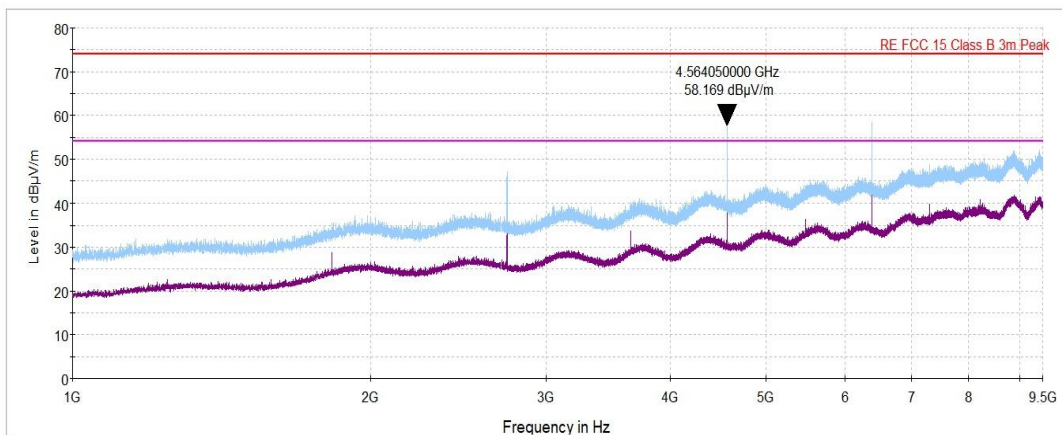

Plot 7.6.8 Radiated emission measurements from 1000 to 9500 MHz at the mid carrier frequency

TEST SITE: Semi anechoic chamber  
 TEST DISTANCE: 3 m  
 ANTENNA POLARIZATION: Vertical and Horizontal

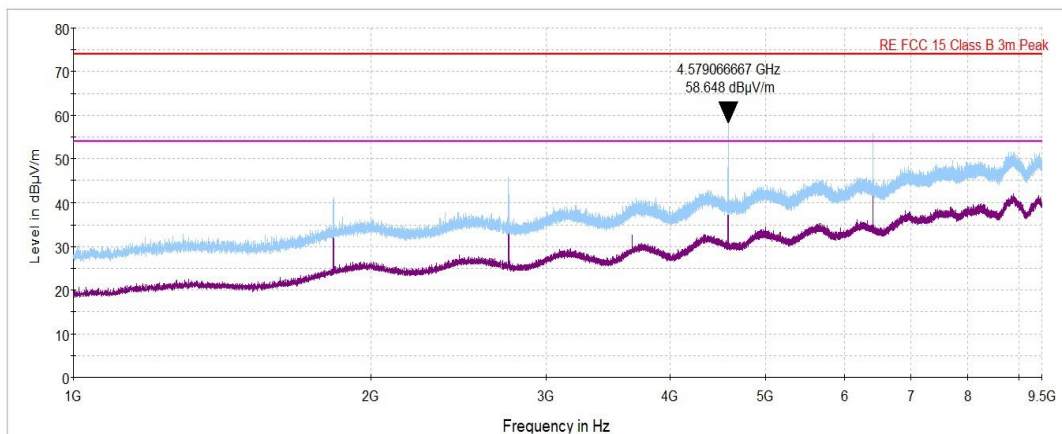





<b>Test specification: Section 15.247(d), RSS-247 section 5.5, Radiated spurious emissions</b>			
Test procedure: ANSI C63.10, sections 6.5, 6.6			
Test mode: Compliance		Verdict: PASS	
Date(s): 02-Feb-23			
Temperature: 21 °C	Relative Humidity: 49 %	Air Pressure: 1007 hPa	Power: 3.7 VDC
Remarks:			

Plot 7.6.9 Radiated emission measurements from 1000 to 9500 MHz at the high carrier frequency

TEST SITE: Semi anechoic chamber  
TEST DISTANCE: 3 m  
ANTENNA POLARIZATION: Vertical and Horizontal

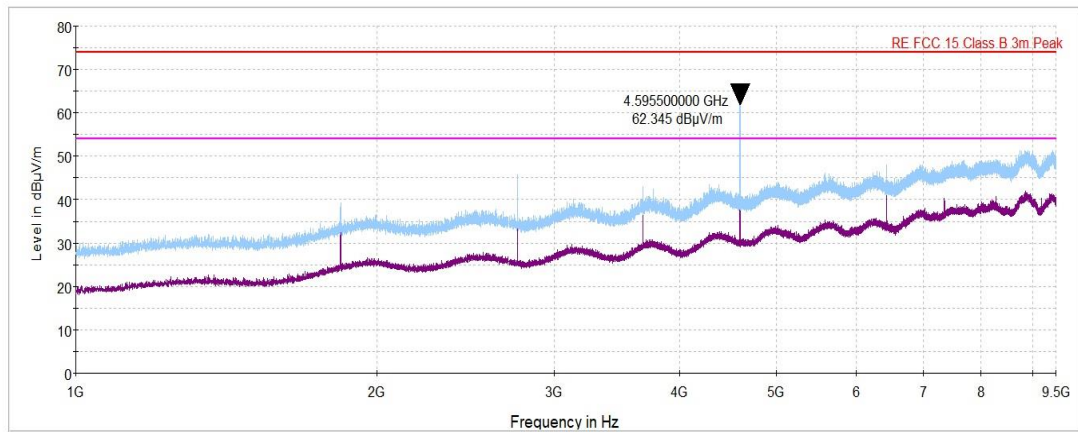



HERMON LABORATORIES

<b>Test specification:</b> Section 15.247(d), RSS-247 section 5.5, Radiated spurious emissions			
<b>Test procedure:</b> ANSI C63.10, sections 6.5, 6.6			
<b>Test mode:</b> Compliance		<b>Verdict:</b> PASS	
<b>Date(s):</b> 02-Feb-23			
<b>Temperature:</b> 21 °C	<b>Relative Humidity:</b> 49 %	<b>Air Pressure:</b> 1007 hPa	<b>Power:</b> 3.7 VDC
<b>Remarks:</b>			

Plot 7.6.10 Transmission pulse duration

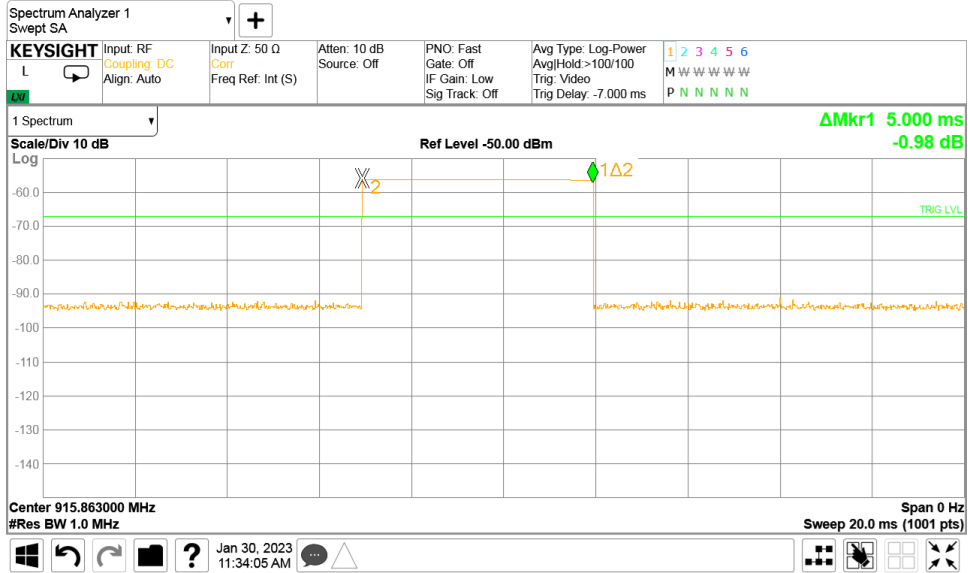

Plot 7.6.11 Transmission pulse period

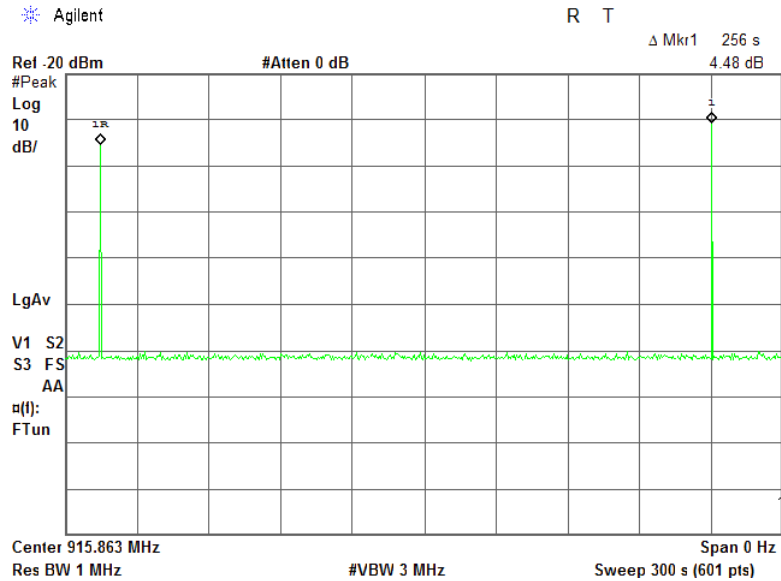



<b>Test specification:</b> Section 15.247(d), RSS-247 section 5.5, Emissions at band edges			
<b>Test procedure:</b> ANSI C63.10, section 7.8.6			
<b>Test mode:</b> Compliance		<b>Verdict:</b> PASS	
<b>Date(s):</b> 05-Feb-23			
<b>Temperature:</b> 20 °C	<b>Relative Humidity:</b> 49 %	<b>Air Pressure:</b> 1008 hPa	<b>Power:</b> 3.7 VDC
<b>Remarks:</b>			

## 7.7 Band edge radiated emissions

### 7.7.1 General

This test was performed to measure emissions, radiated from the EUT at the assigned frequency band edges. Specification test limits are given in Table 7.7.1.

Table 7.7.1 Band edge emission limits

Assigned frequency, MHz	Attenuation below carrier*, dBc	Field strength at 3 m within restricted bands, dB(μV/m)	
		Peak	Average
902.0 – 928.0	20.0	74.0	54.0
2400.0 – 2483.5			
5725.0 – 5850.0			

\* - Band edge emission limit is provided in terms of attenuation below the peak of modulated carrier measured with the same resolution bandwidth.

### 7.7.2 Test procedure

- 7.7.2.1 The EUT was set up as shown in Figure 7.7.1, energized normally modulated at the maximum data rate with its hopping function disabled and its proper operation was checked.
- 7.7.2.2 The EUT was adjusted to produce maximum available to end user RF output power at the lowest carrier frequency.
- 7.7.2.3 The spectrum analyzer span was set to capture the carrier frequency and associated modulation products. The resolution bandwidth was set wider than 1 % of the frequency span.
- 7.7.2.4 The spectrum analyzer was set in max hold mode and allowed trace to stabilize. The highest emission level within the authorized band was measured.
- 7.7.2.5 The maximum band edge emission and modulation product outside of the band were measured as provided in Table 7.7.2 and associated plots and referenced to the highest emission level measured within the authorized band.
- 7.7.2.6 The above procedure was repeated with the EUT adjusted to produce maximum RF output power at the highest carrier frequency.
- 7.7.2.7 The above procedure was repeated with the frequency hopping function enabled.

Figure 7.7.1 Band edge emission test setup





<b>Test specification:</b> Section 15.247(d), RSS-247 section 5.5, Emissions at band edges			
<b>Test procedure:</b> ANSI C63.10, section 7.8.6			
<b>Test mode:</b> Compliance		<b>Verdict:</b> PASS	
<b>Date(s):</b> 05-Feb-23			
<b>Temperature:</b> 20 °C	<b>Relative Humidity:</b> 49 %	<b>Air Pressure:</b> 1008 hPa	<b>Power:</b> 3.7 VDC
<b>Remarks:</b>			

Table 7.7.2 Band edge emission test results

ASSIGNED FREQUENCY RANGE: 902-928 MHz  
DETECTOR USED: Peak  
MODULATION: GFSK  
BIT RATE: 50 kbps  
RESOLUTION BANDWIDTH: ≥ 1% of the span  
VIDEO BANDWIDTH: ≥ RBW

Frequency, MHz	Band edge emission, dBm	Emission at carrier, dBm	Attenuation below carrier, dBc	Limit, dBc	Margin, dB*	Verdict
<b>Frequency hopping disabled</b>						
912.750	-65.66	-31.1	34.56	20.0	14.56	Pass
919.106	-67.78	-14.12	53.66		33.66	
<b>Frequency hopping enabled</b>						
912.750	-66.88	-12.88	54.00	20.0	34.00	Pass
919.106	-67.56	-13.35	54.21		34.21	

\*- Margin = Attenuation below carrier – specification limit.

Reference numbers of test equipment used

HL 5376	HL 4135	HL 3901					
---------	---------	---------	--	--	--	--	--

Full description is given in Appendix A.



<b>Test specification:</b> Section 15.247(d), RSS-247 section 5.5, Emissions at band edges			
<b>Test procedure:</b> ANSI C63.10, section 7.8.6			
<b>Test mode:</b> Compliance		<b>Verdict:</b> PASS	
<b>Date(s):</b> 05-Feb-23			
<b>Temperature:</b> 20 °C	<b>Relative Humidity:</b> 49 %	<b>Air Pressure:</b> 1008 hPa	<b>Power:</b> 3.7 VDC
<b>Remarks:</b>			

Plot 7.7.1 The highest band edge emission at low carrier frequency with hopping function disabled

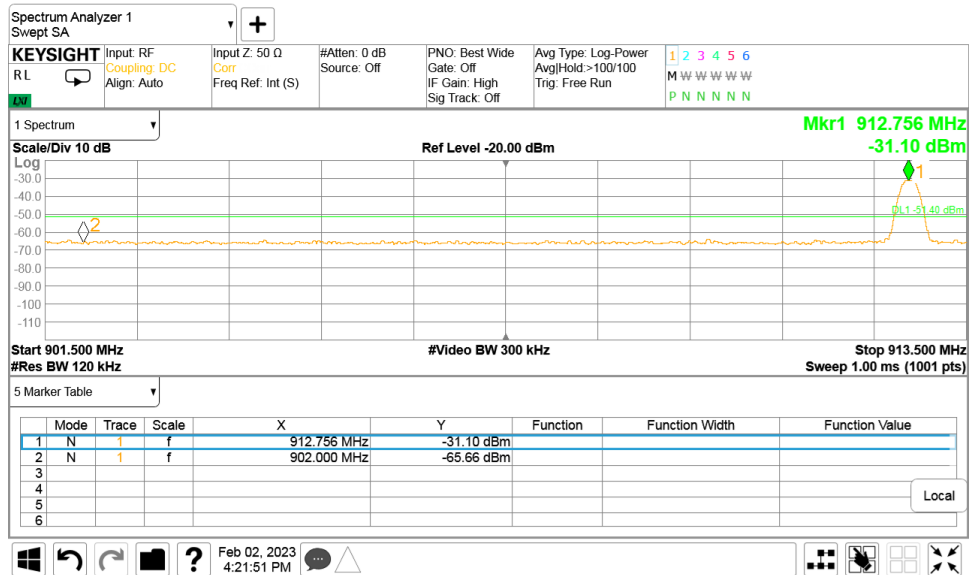

Plot 7.7.2 The highest band edge emission at high carrier frequency with hopping function disabled

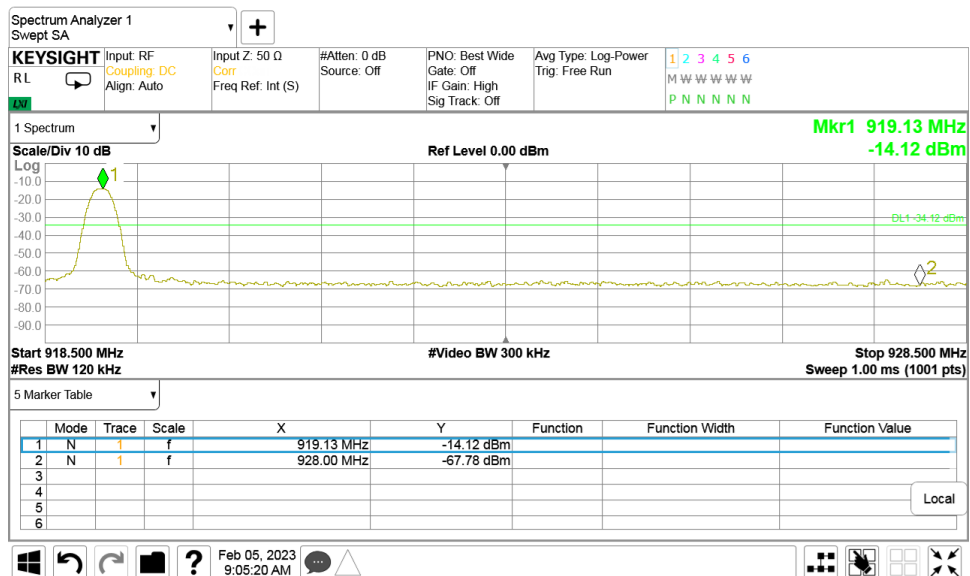



HERMON LABORATORIES

<b>Test specification:</b> Section 15.247(d), RSS-247 section 5.5, Emissions at band edges			
<b>Test procedure:</b> ANSI C63.10, section 7.8.6			
<b>Test mode:</b> Compliance		<b>Verdict:</b> PASS	
<b>Date(s):</b> 05-Feb-23			
<b>Temperature:</b> 20 °C	<b>Relative Humidity:</b> 49 %	<b>Air Pressure:</b> 1008 hPa	<b>Power:</b> 3.7 VDC
<b>Remarks:</b>			

Plot 7.7.3 The highest band edge emission at low carrier frequency with hopping function enabled

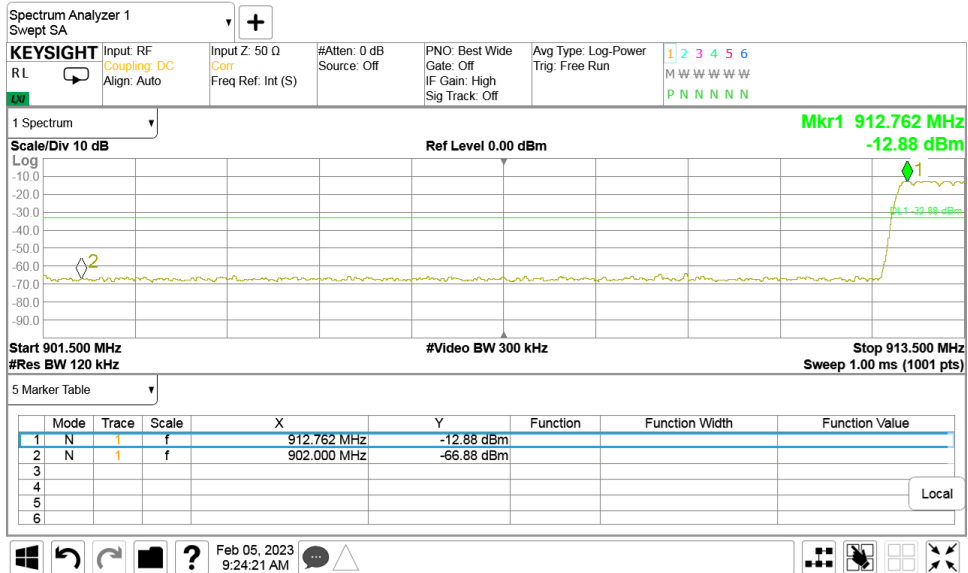

Plot 7.7.4 The highest band edge emission at high carrier frequency with hopping function enabled

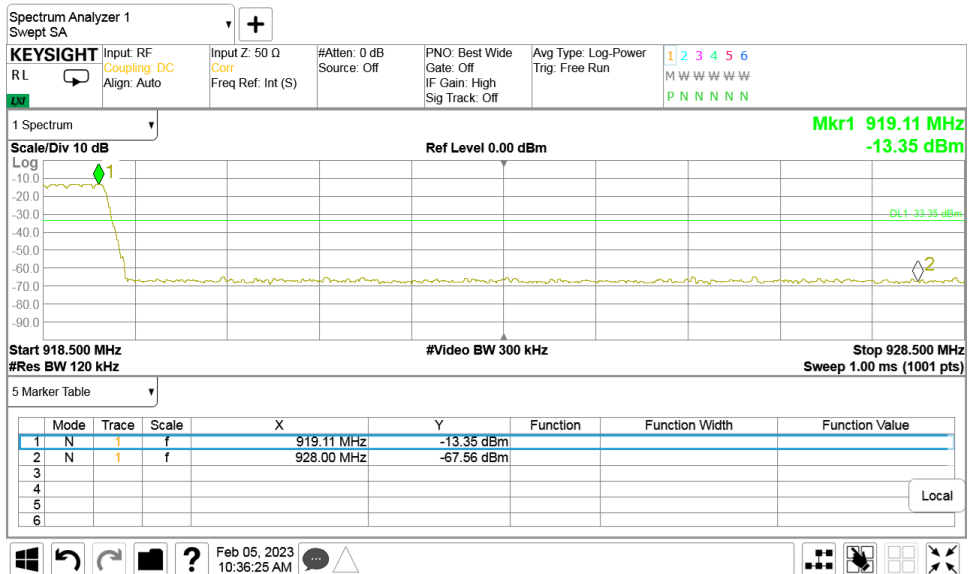



<b>Test specification:</b> FCC 47 CFR, Section 15.207 / RSS-Gen sec.8.8, Conducted emissions			
<b>Test procedure:</b> ANSI C63.4, Section 7.3			
<b>Test mode:</b> Compliance		<b>Verdict:</b> PASS	
<b>Date(s):</b> 09-Feb-23			
<b>Temperature:</b> 21 °C	<b>Relative Humidity:</b> 54 %	<b>Air Pressure:</b> 1012 hPa	<b>Power:</b> 120 VAC, 50 Hz
<b>Remarks:</b>			

## 7.8 Conducted emissions

### 7.8.1 General

This test was performed to measure common mode conducted emissions at the mains power port. Specification test limits are given in Table 8.1.1. The worst test results (the lowest margins) were recorded in Table 8.1.1 and shown in the associated plots.

Table 7.8.1 Limits for conducted emissions

Frequency, MHz	Class B limit, dB(μV)		Class A limit, dB(μV)	
	QP	AVRG	QP	AVRG
0.15 - 0.5	66 - 56*	56 - 46*	79	66
0.5 - 5.0	56	46	73	60
5.0 - 30	60	50	73	60

\* The limit decreases linearly with the logarithm of frequency.

### 7.8.2 Test procedure

7.8.2.1 The EUT was set up as shown in Figure 8.1.1 and associated photographs, energized and the performance check was conducted.

7.8.2.2 The measurements were performed at power terminals with the LISN, connected to a spectrum analyzer in the frequency range referred to in Table 8.1.2. and Table 8.1.3. Unused coaxial connector of the LISN was terminated with 50 Ohm. Quasi-peak and average detectors were used throughout the testing.

7.8.2.3 The position of the device cables was varied to determine maximum emission level.



<b>Test specification: FCC 47 CFR, Section 15.207 / RSS-Gen sec.8.8, Conducted emissions</b>			
<b>Test procedure:</b> ANSI C63.4, Section 7.3			
<b>Test mode:</b> Compliance		<b>Verdict: PASS</b>	
<b>Date(s):</b> 09-Feb-23			
<b>Temperature:</b> 21 °C	<b>Relative Humidity:</b> 54 %	<b>Air Pressure:</b> 1012 hPa	<b>Power:</b> 120 VAC, 50 Hz
<b>Remarks:</b>			

Figure 7.8.1 Setup for conducted emission measurements, table-top equipment

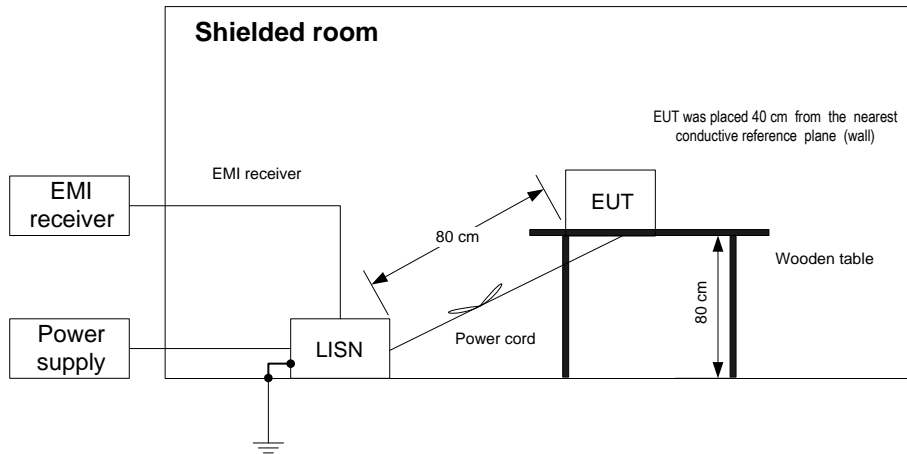





<b>Test specification:</b> FCC 47 CFR, Section 15.207 / RSS-Gen sec.8.8, Conducted emissions			
<b>Test procedure:</b> ANSI C63.4, Section 7.3			
<b>Test mode:</b> Compliance		<b>Verdict:</b> PASS	
<b>Date(s):</b> 09-Feb-23			
<b>Temperature:</b> 21 °C	<b>Relative Humidity:</b> 54 %	<b>Air Pressure:</b> 1012 hPa	<b>Power:</b> 120 VAC, 50 Hz
<b>Remarks:</b>			

Table 7.8.2 Conducted emission test results

LINE: AC mains  
EUT OPERATING MODE: Transmit  
EUT SET UP: TABLE-TOP  
TEST SITE: SHIELDED ROOM  
DETECTORS USED: PEAK / QUASI-PEAK / AVERAGE  
FREQUENCY RANGE: 150 kHz - 30 MHz  
RESOLUTION BANDWIDTH: 9 kHz

Frequency, MHz	Peak emission, dB(μV)	Quasi-peak			Average			Line ID	Verdict
		Measured emission, dB(μV)	Limit, dB(μV)	Margin, dB*	Measured emission, dB(μV)	Limit, dB(μV)	Margin, dB*		
0.366770	NA	45.00	58.57	-13.57	39.20	48.57	-9.37	L1	Pass
0.368815	NA	45.42	58.53	-13.11	39.11	48.53	-9.42		
0.370860	NA	45.26	58.48	-13.22	39.07	48.48	-9.41		
0.372905	NA	45.45	58.44	-12.99	39.04	48.44	-9.40		
0.374950	NA	45.40	58.39	-12.99	38.89	48.39	-9.50		
0.376995	NA	44.51	58.35	-13.84	38.51	48.35	-9.84		
0.366770	NA	40.80	58.57	-17.77	35.10	48.57	-13.47	L2	Pass
0.368815	NA	40.87	58.53	-17.66	35.10	48.53	-13.43		
0.370860	NA	40.98	58.48	-17.50	35.04	48.48	-13.44		
0.372905	NA	41.09	58.44	-17.35	35.04	48.44	-13.40		
0.374950	NA	41.19	58.39	-17.20	34.86	48.39	-13.53		
0.376995	NA	40.66	58.35	-17.69	34.21	48.35	-14.14		

\*- Margin = Measured emission - specification limit.

## Reference numbers of test equipment used

HL 0495	HL 0787	HL 5707	HL 3016	HL 5476			
---------	---------	---------	---------	---------	--	--	--

Full description is given in Appendix A.



HERMON LABORATORIES

<b>Test specification: FCC 47 CFR, Section 15.207 / RSS-Gen sec.8.8, Conducted emissions</b>			
<b>Test procedure:</b> ANSI C63.4, Section 7.3			
<b>Test mode:</b> Compliance		<b>Verdict: PASS</b>	
<b>Date(s):</b> 09-Feb-23			
<b>Temperature:</b> 21 °C	<b>Relative Humidity:</b> 54 %	<b>Air Pressure:</b> 1012 hPa	<b>Power:</b> 120 VAC, 50 Hz
<b>Remarks:</b>			

**Plot 7.8.1 Conducted emission measurements**

LINE: L1  
 EUT OPERATING MODE: Transmit  
 LIMIT: QUASI-PEAK, AVERAGE  
 DETECTOR: PEAK

