



FCC LISTED, REGISTRATION
NUMBER: 2764.01

ISED LISTED REGISTRATION
NUMBER: 23595-1

Test report No:
3277ERM.002A1

Partial Test report

Reference Standard:
USA FCC Part 24 & 27
CANADA ISED RSS-130/ RSS-133/ RSS-139

(*) Identification of item tested	Cellular Alarm Communicator
(*) Trademark	DSC/Tyco/JCI
(*) Model and /or type reference	LE4000E
Other identification of the product	FCC ID: F5321LE4000E IC: 160A-LE4000E IMEI TAC: 35766179 and 35949118
(*) Features	LTE
Manufacturer	Tyco Safety Products Canada Ltd. 3301 Langstaff Rd., Concord, ON L4K 4L2 Canada.
Test method requested, standard	USA FCC Part 24 10-1-20 Edition USA FCC Part 27 10-1-20 Edition CANADA IC RSS-133 Issue 6, Jan. 2013 (Amendment January 2018); CANADA IC RSS-130 Issue 2, Feb 2019. CANADA IC RSS-139 Issue 3, July 2015. CANADA IC RSS-Gen Issue 5, April 2018. Measurement Guidance 971168 D01 v02r02 for certification of Licensed Digital Transmitters. ANSI C63.26 – 2015.
Summary	IN COMPLIANCE
Approved by (name / position & signature)	Domingo Galvez EMC&RF Lab Manager
Date of issue	07-01-2021
Report template No	FDT08_23 (*) "Data provided by the client"

Index

Competences and guarantees	3
General conditions	3
Uncertainty	3
Data provided by the client.....	4
Usage of samples	4
Test sample description	6
Identification of the client.....	7
Testing period and place.....	7
Document history	7
Modifications to the reference test report	8
Environmental conditions	8
Remarks and comments	8
Testing verdicts.....	9
Summary	9
List of equipment used during the test.....	10
Appendix A: FCC 24 Results	11
Appendix B: FCC 27 Results	29

Competences and guarantees

DEKRA Certification Inc. is a testing laboratory accredited by A2LA (The American Association for Laboratory Accreditation), to perform the tests indicated in the Certificate 2764.01

DEKRA Certification Inc. is a testing laboratory competent to carry out the tests described in this report.

In order to assure the traceability to other national and international laboratories, DEKRA Certification Inc. has a calibration and maintenance program for its measurement equipment.

DEKRA Certification Inc. guarantees the reliability of the data presented in this report, which is the result of the measurements and the tests performed to the item under test on the date and under the conditions stated on the report and, it is based on the knowledge and technical facilities available at DEKRA Certification at the time of performance of the test.

DEKRA Certification Inc. is liable to the client for the maintenance of the confidentiality of all information related to the item under test and the results of the test.

The results presented in this Test Report apply only to the particular item under test established in this document.

IMPORTANT: No parts of this report may be reproduced or quoted out of context, in any form or by any means, except in full, without the previous written permission of DEKRA Certification Inc.

General conditions

1. This report is only referred to the item that has undergone the test.
2. This report does not constitute or imply on its own an approval of the product by the Certification Bodies or competent Authorities.
3. This document is only valid if complete; no partial reproduction can be made without previous written permission of DEKRA Certification Inc.
4. This test report cannot be used partially or in full for publicity and/or promotional purposes without previous written permission of DEKRA Certification Inc. and the Accreditation Bodies.

Uncertainty

Uncertainty (factor k=2) was calculated according to the DEKRA Certification internal document PODT000.

	Frequency (MHz)	U(k=2)	Units
Radiated Spurious Emission	30-180	4.27	dB
	180-1000	3.14	dB
	1000-18000	3.30	dB
	18000-40000	3.49	dB
RF Power	---	0.88	dB

Data provided by the client

The LE4000E is fire and burglary alarm communicator that connects to an alarm system and sends fire and burg alarm events from protected premises to supervising station receiver using the LTE network.

DEKRA declines any responsibility with respect to the information provided by the client and that may affect the validity of results.

Usage of samples

Samples undergoing test have been selected by: The client.

Sample S/01 is composed of the following elements:

Control N°	Description	Model	Serial N°	Date of reception
3277.07	LTE Wireless alarm communicator	LE4000E	89014103273355544648	5/26/2021

Sample S/01 is composed of the following Accessory elements:

Control N°	Description	Model	Serial N°	Date of reception
3277.09	Power supply	SOY-1380100US	--	5/26/2021
3277.13	USB to RS232 Adapter	--	--	5/26/2021
3277.14	RJ11 female to DB9 female adapter	--	--	5/26/2021
3277.15	Telephone cable	--	--	5/26/2021
3277.16	RJ11 Board for testing	--	--	5/26/2021

Sample S/01 was used in following testing:

All Conducted tests mentioned in Appendix A & B.

Sample S/02 is composed of the following elements:

Control N°	Description	Model	Serial N°	Date of reception
3277/04	LTE Wireless alarm communicator	LE4000E	89014103273355544697	5/26/2021
3277/05	LTE External antenna	-	-	5/26/2021

Sample S/02 is composed of the following Accessory elements:

Control N°	Description	Model	Serial N°	Date of reception
3277/06	LTE Power supply	SOY-1380100US	-	5/26/2021

Sample S/02 was used in following testing:

All Radiated tests mentioned in Appendix A & B.

Test sample description

Ports..... :	Port name and description		Cable				
			Specified length [m]	Attached during test		Shielded	
	Z1, Z2 Inputs		10	<input checked="" type="checkbox"/>		<input type="checkbox"/>	
	PGM1, PGM2 Outputs		10	<input checked="" type="checkbox"/>		<input type="checkbox"/>	
	Tip, Ring, T1, R1		10	<input checked="" type="checkbox"/>		<input type="checkbox"/>	
	DC +/-		2	<input checked="" type="checkbox"/>		<input type="checkbox"/>	
			<input type="checkbox"/>		<input type="checkbox"/>		
			<input type="checkbox"/>		<input type="checkbox"/>		
Supplementary information to the ports..... :	use regular quad wire 22AWG						
Rated power supply	Voltage and Frequency		Reference poles				
			L1	L2	L3	N	PE
	<input type="checkbox"/>	AC: 230Vac / 50Hz.	<input type="checkbox"/>	<input type="checkbox"/>	<input type="checkbox"/>	<input type="checkbox"/>	<input type="checkbox"/>
	<input type="checkbox"/>	AC:	<input type="checkbox"/>	<input type="checkbox"/>	<input type="checkbox"/>	<input type="checkbox"/>	<input type="checkbox"/>
	<input checked="" type="checkbox"/>	DC: 13.8 V/1A					
<input type="checkbox"/>	DC:						
Rated Power	15VA						
Clock frequencies.....	4MHz						
Other parameters							
Software version	5.10						
Hardware version	UA724 Rev. 01						
Dimensions in cm (L x W x D).....							
Mounting position	<input type="checkbox"/>	Table top equipment					
	<input checked="" type="checkbox"/>	Wall/Ceiling mounted equipment					
	<input type="checkbox"/>	Floor standing equipment					
	<input type="checkbox"/>	Hand-held equipment					
	<input type="checkbox"/>	Other:					
Modules/parts..... :	Module/parts of test item		Type		Manufacturer		
	LE4000E		EUT		Tyco		

Accessories (not part of the test item)	Description	Type	Manufacturer
	Power supply	AC/DC adapter	SOY
Documents as provided by the applicant	Description	File name	Issue date
	FDT30_18 Declaration Equipment Data	FDT30_18 Declaration Equipment Data (002)-LE4000E.pdf	05-27-2021

Copy of marking plate:

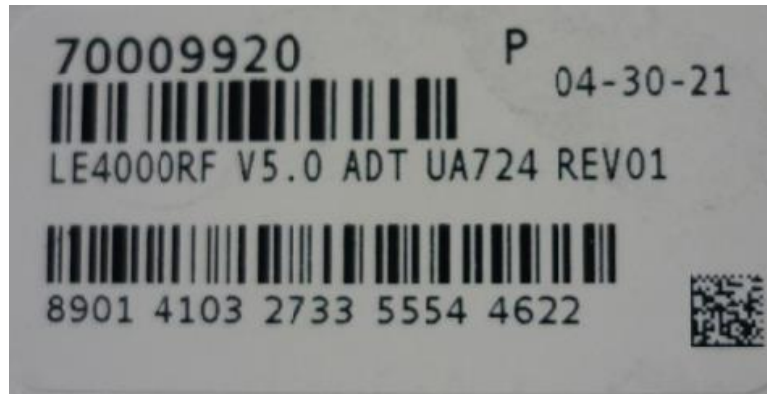

Identification of the client

Tyco Safety Products Canada Ltd.
3301 Langstaff Rd., Concord, ON L4K 4L2 Canada.

Testing period and place

Test Location	DEKRA Certification, Inc.
Date (start)	05-28-2021
Date (finish)	06-07-2021

Document history

Report number	Date	Description
3277ERM.002	06-09-2021	First release
3277ERM.002A1	07-01-2021	Second release

Modifications to the reference test report

It was introduced the following modification in respect to the test report number 3277ERM.002 related with the same samples:

Clauses/ Sub-Clauses	Modification	Justification
Page 14-17/TEST A.1 RF OUTPUT POWER	Antenna gain information has been updated	According to Customer instructions
Page 33-38/TEST B.1 RF OUTPUT POWER	Antenna gain information has been updated	According to Customer instructions

This modification test report cancels and replaces the test report 3277ERM.002.

Environmental conditions

In the control chamber, the following limits were not exceeded during the test:

Temperature	Min. = 15 °C Max. = 35 °C
Relative humidity	Min. = 30 % Max. = 75 %
Air pressure	Min. = 860 mbar Max. = 1060 mbar

In the semi anechoic chamber, the following limits were not exceeded during the test.

Temperature	Min. = 15 °C Max. = 35 °C
Relative humidity	Min. = 30 % Max. = 75 %
Air pressure	Min. = 860 mbar Max. = 1060 mbar

In the chamber for conducted measurements, the following limits were not exceeded during the test:

Temperature	Min. = 15 °C Max. = 35 °C
Relative humidity	Min. = 30 % Max. = 60 %
Air pressure	Min. = 860 mbar Max. = 1060 mbar

Remarks and comments

The tests have been performed by the technical personnel: Sravani Gollamudi, Lourdes Maria Valverde and Koji Nishimoto.

Testing verdicts

Not applicable :	N/A
Pass :	P
Fail :	F
Not measured :	N/M

Summary

FCC PART 24 PARAGRAPH					
Section	FCC Spec Clause	RSS Spec Clause	Test Description	Verdict	Remark
A.1	§2.1046 and §24.232	RSS-133 Clause 6.4	RF Output power	P	N/A
-	§2.1047	RSS-133 Clause 6.2	Modulation characteristics	N/A	Refer 1
-	§2.1055 and § 24.235	RSS-133 Clause 6.3	Frequency stability	N/A	Refer 1
-	§ 2.1049	RSS-133 Clause 2.3	Occupied Bandwidth	N/A	Refer 1
-	§2.1051 and §24.238	RSS-133 Clause 6.5	Spurious emissions at antenna terminals	N/A	Refer 1
A.2	§24.238	RSS-133 Clause 6.5	Radiated emissions	P	N/A
<u>Supplementary information and remarks:</u>					
Note 1: Test case Not requested by the customer.					

FCC PART 27 PARAGRAPH					
Section	FCC Spec Clause	RSS Spec Clause	Test Description	Verdict	Remark
B.1	§2.1046 and §27.50	RSS-130 Clause 4.6/ RSS-139 Clause 6.5	RF Output power	P	N/A
-	§2.1047 and §27.50	RSS-130 Clause 4.2/ RSS- Clause 6.2	Modulation characteristics	N/A	Refer 1
-	§2.1055 and § 27.54	RSS-130 Clause 4.5 / RSS- Clause 6.4	Frequency stability	N/A	Refer 1
-	§ 2.1049	RSS GEN Clause 6.7	Occupied Bandwidth	N/A	Refer 1
-	§2.1051 and §27.53	RSS-130 Clause 4.7/ RSS- Clause 6.6	Spurious emissions at antenna terminals	N/A	Refer 1
B.2	§27.53	RSS-130 Clause 4.7/ RSS- Clause 6.6	Radiated emissions	P	N/A
<u>Supplementary information and remarks:</u>					
Note 2: Test case Not requested by the customer.					

List of equipment used during the test

Conducted Measurements

CONTROL NUMBER	DESCRIPTION	MANUFACTURER	MODEL	LAST CALIBRATION	NEXT CALIBRATION
1149	WIDEBAND RADIO COMMUNICATION TESTER,	ROHDE & SCHWARZ	CMW500	2019/09	2021/09
1107	Ethernet SNMP Thermometer	HW GROUP	HWg-STE Plain	2020/08	2021/08

Radiated Measurements

CONTROL NUMBER	DESCRIPTION	MANUFACTURER	MODEL	LAST CALIBRATION	NEXT CALIBRATION
1012	EMI Test Receiver	ROHDE & SCHWARZ	ESR26	2019/12	2021/12
1014	Signal Analyzer	ROHDE & SCHWARZ	FSV40	2021/05	2023/05
1057	Double Ridged Waveguide Horn Antenna	ETS LINDGREN	3115	2020/06	2023/06
1065	Biconilog Antenna	ETS LINDGREN	3142E	2020/08	2023/08
1149	WIDEBAND RADIO COMMUNICATION TESTER,	ROHDE & SCHWARZ	CMW500	2019/09	2021/09
1179	EMC measurement software	ROHDE & SCHWARZ	EMC32 V9.01	N/A	N/A
1108	Ethernet SNMP Thermometer- SAC	HW GROUP	HWg-STE Plain	2020/08	2021/08
1111	Ethernet SNMP Thermometer- SAC	HW GROUP	HWg-STE Plain	2020/08	2021/08
1314	WIRELESS MEASUREMENT SOFTWARE R&S EMC32	ROHDE & SCHWARZ	-	N/A	N/A

Appendix A: FCC 24 Results

Appendix A Content

DESCRIPTION OF TEST CONDITIONS	13
TEST A.1: RF OUTPUT POWER.....	14
TEST A.2: RADIATED EMISSIONS.....	18

DESCRIPTION OF TEST CONDITIONS

The worst case was found when positioned as the table below. Following channel(s) was (were) selected for the final test as listed below:

TEST CONDITIONS	DESCRIPTION										
<p>TC#01 LTE Band 2</p>	<p><u>Power supply (V):</u> $V_{\text{nominal}} = 13.8 \text{ Vdc}$</p> <p><u>Type of power supply:</u> DC voltage from power supply.</p> <p><u>Test Frequencies for Conducted tests:</u></p> <p><u>1.4 MHz Bandwidth:</u> -Lowest Channel: 18607(1850.7 MHz) -Middle Channel: 18900(1880 MHz) -Highest Channel: 19193(1909.3 MHz)</p> <p><u>3 MHz Bandwidth:</u> -Lowest Channel: 18615(1851.5 MHz) -Middle Channel: 18900(1880 MHz) -Highest Channel: 19185(1908.5 MHz)</p> <p><u>5 MHz Bandwidth:</u> -Lowest Channel: 18625(1852.5 MHz) -Middle Channel: 18900(1880 MHz) -Highest Channel: 19175(1907.5 MHz)</p> <p><u>10 MHz Bandwidth:</u> -Lowest Channel: 18650(1855 MHz) -Middle Channel: 18900(1880 MHz) -Highest Channel: 19150(1905 MHz)</p> <p><u>15 MHz Bandwidth:</u> -Lowest Channel: 18675(1857.5 MHz) -Middle Channel: 18900(1880 MHz) -Highest Channel: 19125(1902.5 MHz)</p> <p><u>20 MHz Bandwidth:</u> -Lowest Channel: 18700(1860 MHz) -Middle Channel: 18900(1880 MHz) -Highest Channel: 19100(1900 MHz)</p> <p><u>Test Frequencies for Radiated tests:</u></p> <table border="1" data-bbox="411 1691 1332 1899"> <thead> <tr> <th>Available Frequencies</th> <th>Tested Frequency</th> <th>Channel Bandwidth</th> <th>Modulation</th> <th>Mode</th> </tr> </thead> <tbody> <tr> <td>1850 to 1910 MHz</td> <td>1860 MHz 1880 MHz 1900 MHz</td> <td>20 MHz</td> <td>QPSK</td> <td>1 RB</td> </tr> </tbody> </table> <p>Note: This device was tested under all bandwidths, RB configurations and modulations. The worst case found in QPSK modulation.</p>	Available Frequencies	Tested Frequency	Channel Bandwidth	Modulation	Mode	1850 to 1910 MHz	1860 MHz 1880 MHz 1900 MHz	20 MHz	QPSK	1 RB
Available Frequencies	Tested Frequency	Channel Bandwidth	Modulation	Mode							
1850 to 1910 MHz	1860 MHz 1880 MHz 1900 MHz	20 MHz	QPSK	1 RB							

TEST A.1: RF OUTPUT POWER

LIMITS:	Product standard:	FCC Part 24 / IC RSS-133
	Test standard:	FCC §2.1046 and §24.232 / RSS-133 Clause 6.4

LIMITS

The ERP of mobile transmitters and auxiliary test transmitters must not exceed 7 Watts.

RSS-132 Clause 5.4

The transmitter output power shall be measured in terms of average power. The equivalent isotropically radiated power (e.i.r.p.) for mobile equipment shall not exceed 11.5 watts. Refer to SRSP-503 for base station e.i.r.p. limits.

In addition, the peak-to-average power ratio (PAPR) of the transmitter shall not exceed 13 dB for more than 0.1% of the time using a signal corresponding to the highest PAPR during periods of continuous transmission.

TEST SETUP



TESTED SAMPLES:	S/01
TESTED CONDITIONS MODES:	TC#01
TEST RESULTS:	PASS

LTE QPSK MODULATION. Bandwidth = 1.4 MHz, RB: 3, Offset: 1

Channel	Average power at antenna port (dBm)	Maximum declared antenna gain (dBi)	Maximum E.I.R.P. average power (dBm)
Lowest	22.21	5.20	27.41
Middle	22.80	5.20	28.00
Highest	22.74	5.20	27.94

LTE 16QAM MODULATION. Bandwidth = 1.4 MHz, RB: 3, Offset: 1

Channel	Average power at antenna port (dBm)	Maximum declared antenna gain (dBi)	Maximum E.I.R.P. average power (dBm)
Lowest	21.62	5.20	26.82
Middle	22.05	5.20	27.25
Highest	21.78	5.20	26.98

LTE QPSK MODULATION. Bandwidth = 3 MHz, RB: 1, Offset: 0

Channel	Average power at antenna port (dBm)	Maximum declared antenna gain (dBi)	Maximum E.I.R.P. average power (dBm)
Lowest	22.45	5.20	27.65
Middle	22.46	5.20	27.66
Highest	22.47	5.20	27.67

LTE 16QAM MODULATION. Bandwidth = 3 MHz, RB: 1, Offset: 0

Channel	Average power at antenna port (dBm)	Maximum declared antenna gain (dBi)	Maximum E.I.R.P. average power (dBm)
Lowest	21.67	5.20	26.87
Middle	21.51	5.20	26.71
Highest	21.53	5.20	26.73

TEST RESULTS (Cont.):

LTE QPSK MODULATION. Bandwidth = 5 MHz, RB: 1, Offset: 0

Channel	Average power at antenna port (dBm)	Maximum declared antenna gain (dBi)	Maximum E.I.R.P. average power (dBm)
Lowest	22.36	5.20	27.56
Middle	22.11	5.20	27.31
Highest	22.68	5.20	27.88

LTE 16QAM MODULATION. Bandwidth = 5 MHz, RB: 1, Offset: 0

Channel	Average power at antenna port (dBm)	Maximum declared antenna gain (dBi)	Maximum E.I.R.P. average power (dBm)
Lowest	21.52	5.20	26.72
Middle	21.34	5.20	26.54
Highest	21.54	5.20	26.74

LTE QPSK MODULATION. Bandwidth = 10 MHz, RB: 1, Offset: 24

Channel	Average power at antenna port (dBm)	Maximum declared antenna gain (dBi)	Maximum E.I.R.P. average power (dBm)
Lowest	22.64	5.20	27.84
Middle	22.73	5.20	27.93
Highest	22.82	5.20	28.02

LTE 16QAM MODULATION. Bandwidth = 10 MHz, RB: 1, Offset: 24

Channel	Average power at antenna port (dBm)	Maximum declared antenna gain (dBi)	Maximum E.I.R.P. average power (dBm)
Lowest	21.68	5.20	26.88
Middle	22.01	5.20	27.21
Highest	22.45	5.20	27.65

TEST RESULTS (Cont.):

LTE QPSK MODULATION. Bandwidth = 15 MHz, RB: 1, Offset: 37

Channel	Average power at antenna port (dBm)	Maximum declared antenna gain (dBi)	Maximum E.I.R.P. average power (dBm)
Lowest	22.60	5.20	27.80
Middle	22.88	5.20	28.08
Highest	22.48	5.20	27.68

LTE 16QAM MODULATION. Bandwidth = 15 MHz, RB: 1, Offset: 37

Channel	Average power at antenna port (dBm)	Maximum declared antenna gain (dBi)	Maximum E.I.R.P. average power (dBm)
Lowest	21.80	5.20	27.00
Middle	22.10	5.20	27.30
Highest	22.07	5.20	27.27

LTE QPSK MODULATION. Bandwidth = 20 MHz, RB: 1, Offset: 49

Channel	Average power at antenna port (dBm)	Maximum declared antenna gain (dBi)	Maximum E.I.R.P. average power (dBm)
Lowest	22.41	5.20	27.61
Middle	22.27	5.20	27.47
Highest	22.95	5.20	28.15

LTE 16QAM MODULATION. Bandwidth = 20 MHz, RB: 1, Offset: 49

Channel	Average power at antenna port (dBm)	Maximum declared antenna gain (dBi)	Maximum E.I.R.P. average power (dBm)
Lowest	21.26	5.20	26.46
Middle	21.58	5.20	26.78
Highest	21.83	5.20	27.03

TEST A.2: RADIATED EMISSIONS

LIMITS:	Product standard:	FCC Part 24 / IC RSS-133
	Test standard:	FCC §2.1053 and §24.238 /RSS-133 Clause 6.5

LIMITS

According to specification. the power of emissions shall be attenuated below the transmitter power (P) by a factor of at least $43 + 10 \log (P)$ dB. P in watts.

At P_o transmitting power. the specified minimum attenuation becomes $43+10\log (P_o)$. and the level in dBm relative P_o becomes:

$$P_o \text{ (dBm)} - [43 + 10 \log (P_o \text{ in mwatts}) - 30] = -13 \text{ dBm}$$

TEST SETUP

The measurement was performed with the EUT inside an anechoic chamber. The spectrum was scanned from 30 MHz to at least the 10th harmonic of the highest frequency generated within the equipment.

The EUT was placed on a non-conductive stand at a 3-meter distance from the measuring antenna for measurements up to 18 GHz and at 1 m distance for measurements above 18 GHz.

Detected emissions were maximized at each frequency by rotating the EUT and adjusting the measuring antenna height and polarization. The maximum meter reading was recorded.

Radiated measurements < 1 GHz

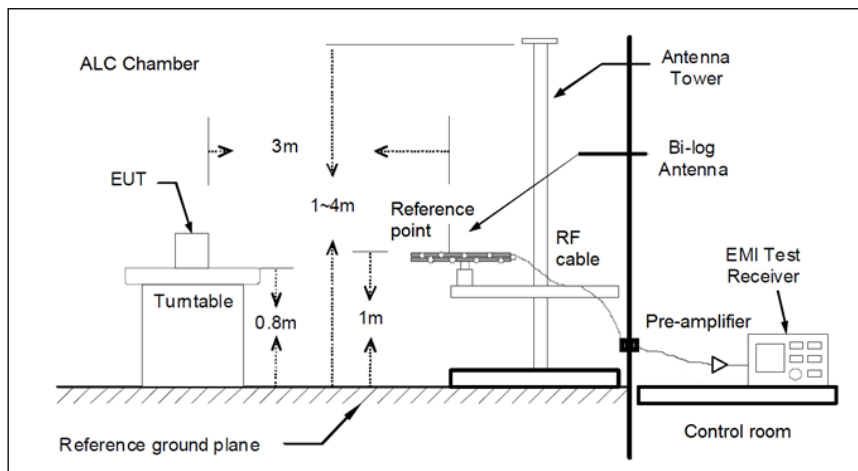

TEST SETUP

Continued

Radiated measurements < 18 GHz

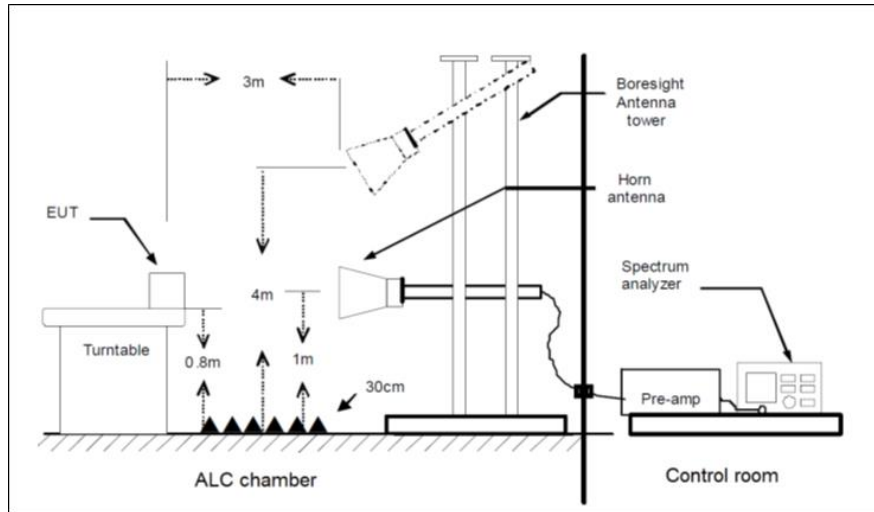

Radiated measurements > 18 GHz

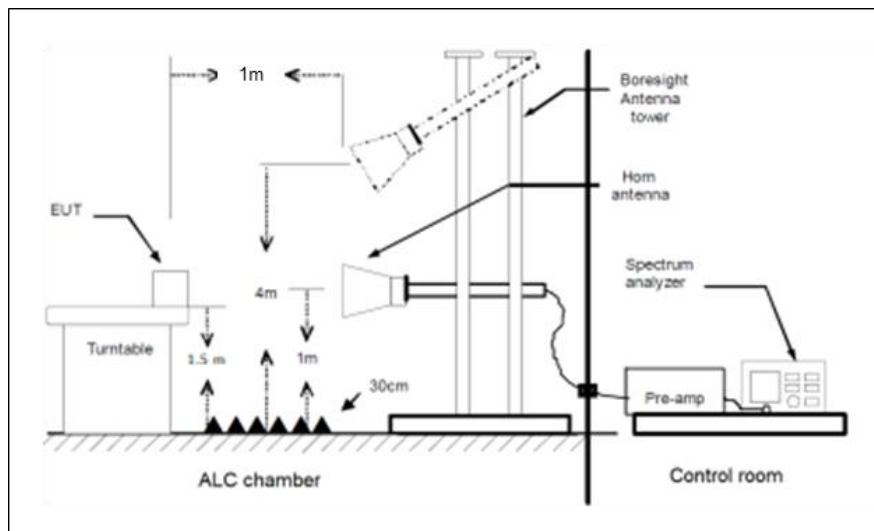

TESTED SAMPLES:	S/02
TESTED CONDITIONS MODES:	TC#01
TEST RESULTS:	PASS

RESULTS

A preliminary scan determined the QPSK 20 MHz bandwidth and a single RB configuration as the worst case based on the conducted RF output power test.

The following plots show the results for this configuration.

LTE QPSK MODULATION. RB = 1. Offset = 49. BW = 20 MHz

TEST RESULTS (Cont.):	Lowest Channel
------------------------------	----------------

FREQUENCY RANGE: 30-1000 MHz

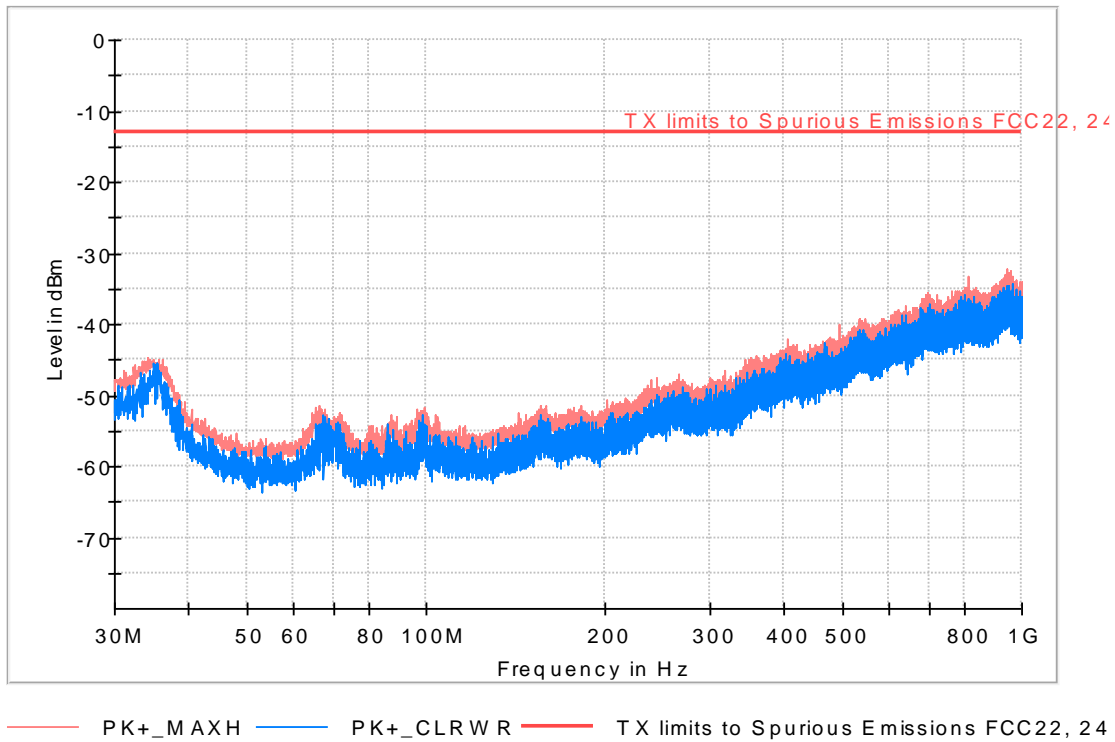

Frequency (MHz)	PK+_CLRWR (dBm)	PK+_MAXH (dBm)	Pol	Margin - PK+ (dB)	Limit - PK+ (dBm)
34.138667	-50.0	-44.7	V	31.7	-13.0
945.421333	-37.6	-32.1	V	19.1	-13.0

TEST RESULTS (Cont.):

Lowest Channel

FREQUENCY RANGE: 1-18 GHz

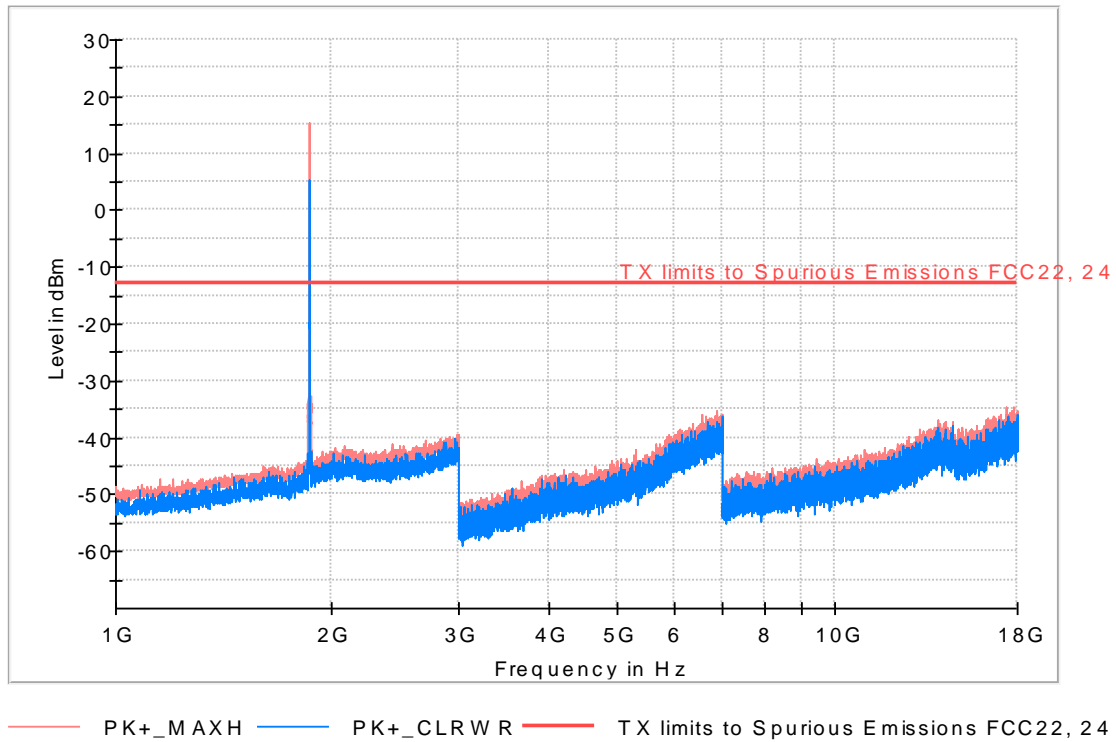

Frequency (MHz)	PK+_CLRWR (dBm)	PK+_MAXH (dBm)	Pol	Margin - PK+ (dB)	Limit - PK+ (dBm)	Comment
1860.000000	5.3	15.4	V	---	---	Uplink

TEST RESULTS (Cont.):

Lowest Channel

FREQUENCY RANGE: 18-20 GHz

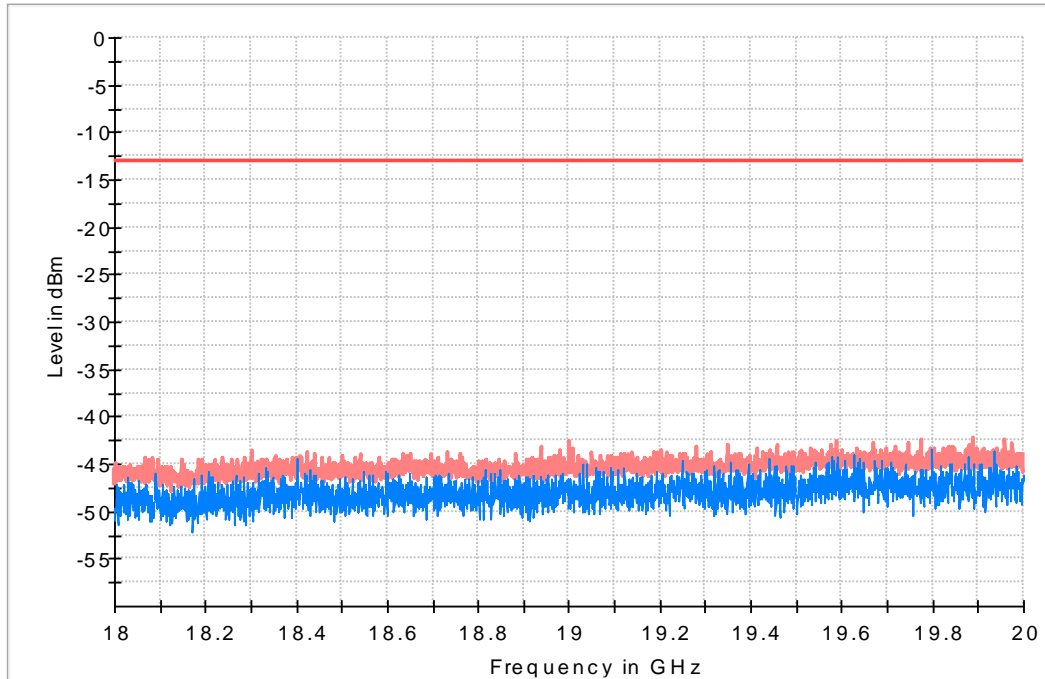

— PK+_MAXH — PK+_CLRW R — TX limits to Spurious Emissions FCC22, 24

Frequency (MHz)	PK+_CLRW R (dBm)	PK+_MAXH (dBm)	Pol	Margin - PK+ (dB)	Limit - PK+ (dBm)
18884.125000	-49.2	-44.1	V	31.1	-13.0

TEST RESULTS (Cont.):

Middle Channel

FREQUENCY RANGE: 30 MHz-1 GHz

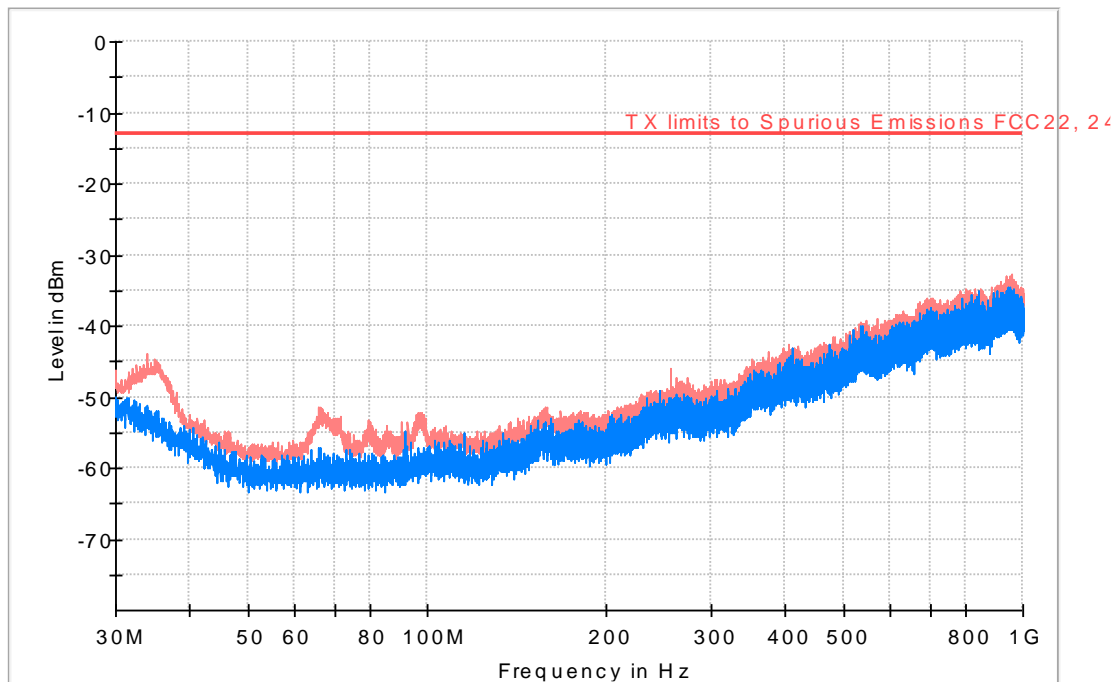

— PK+_MAXH — PK+_CLRWR — TX limits to Spurious Emissions FCC22, 24

Frequency (MHz)	PK+_CLRWR (dBm)	PK+_MAXH (dBm)	Pol	Margin - PK+ (dB)	Limit - PK+ (dBm)
33.847667	-52.2	-44.0	V	31.0	-13.0
958.710333	-39.2	-32.7	H	19.7	-13.0

TEST RESULTS (Cont.):

Middle Channel

FREQUENCY RANGE: 1-18 GHz

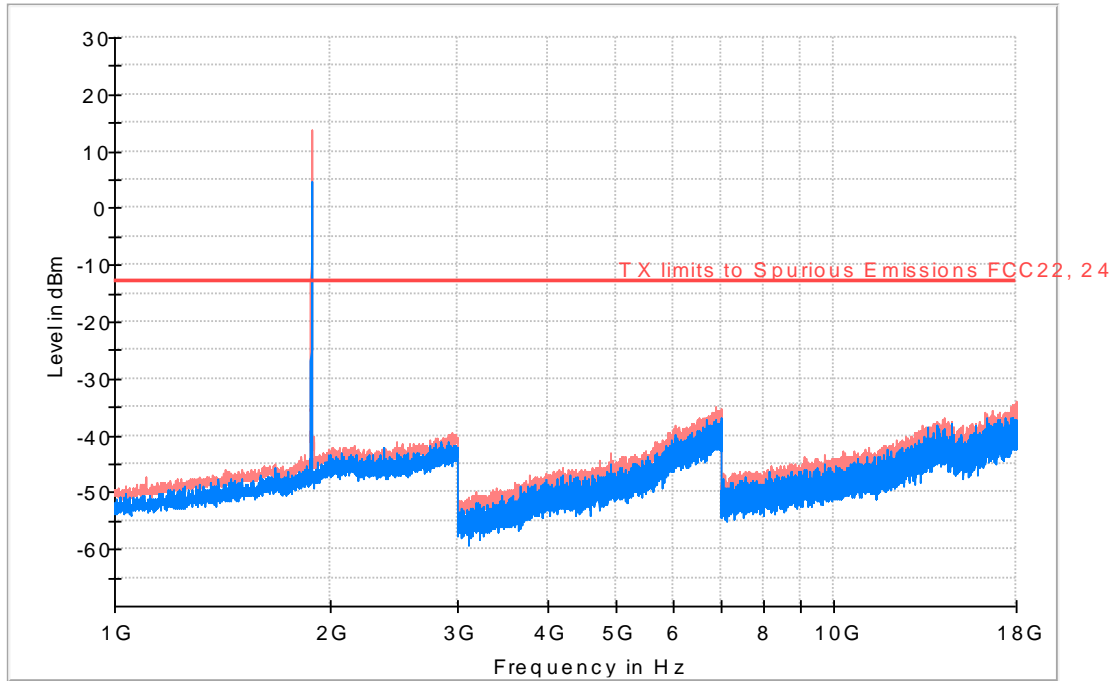

— PK+_MAXH — PK+_CLRWR — TX limits to Spurious Emissions FCC22, 24

Frequency (MHz)	PK+_CLRWR (dBm)	PK+_MAXH (dBm)	Pol	Margin - PK+ (dB)	Limit - PK+ (dBm)	Comment
1880.000000	4.6	13.7	V	---	---	Uplink

TEST RESULTS (Cont.):

Middle Channel

FREQUENCY RANGE: 18-20 GHz

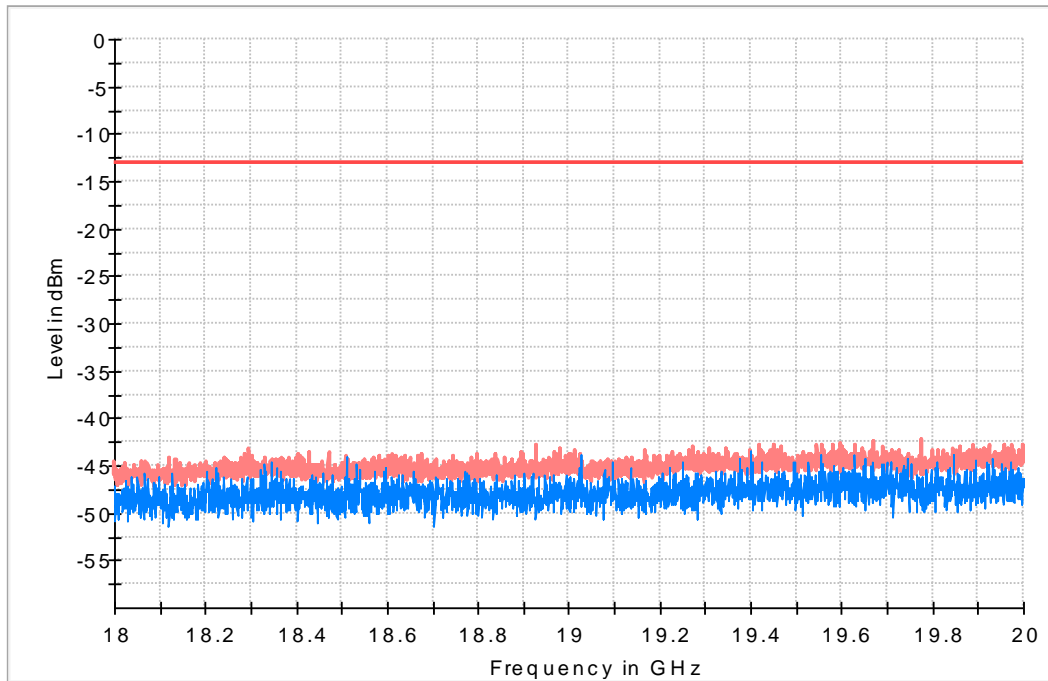

— PK+_MAXH — PK+_CLRWR — TX limits to Spurious Emissions FCC22, 24

Frequency (MHz)	PK+_CLRWR (dBm)	PK+_MAXH (dBm)	Pol	Margin - PK+ (dB)	Limit - PK+ (dBm)
18928.125000	-49.1	-42.8	V	29.8	-13.0

TEST RESULTS (Cont.):

Highest Channel

FREQUENCY RANGE: 30 MHz-1 GHz

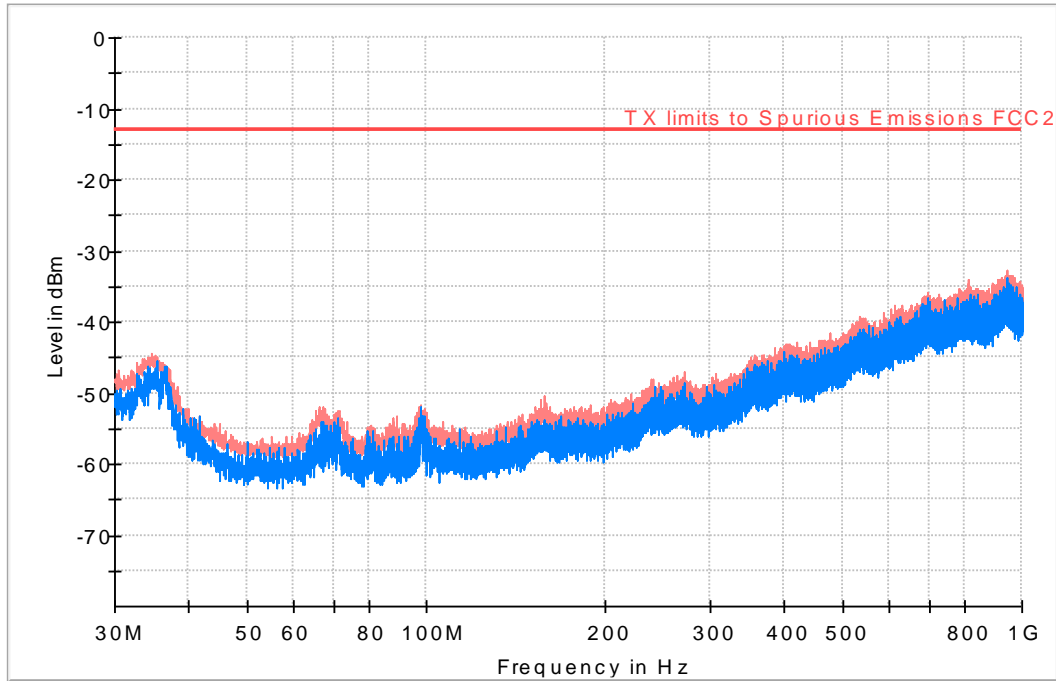

— PK+_MAXH — PK+_CLRWR — TX limits to Spurious Emissions FCC22, 24

Frequency (MHz)	PK+_CLRWR (dBm)	PK+_MAXH (dBm)	Pol	Margin - PK+ (dB)	Limit - PK+ (dBm)
34.688333	-48.5	-44.4	V	31.4	-13.0
943.416667	-37.9	-32.8	H	19.8	-13.0

TEST RESULTS (Cont.):

Highest Channel

FREQUENCY RANGE: 1-18 GHz

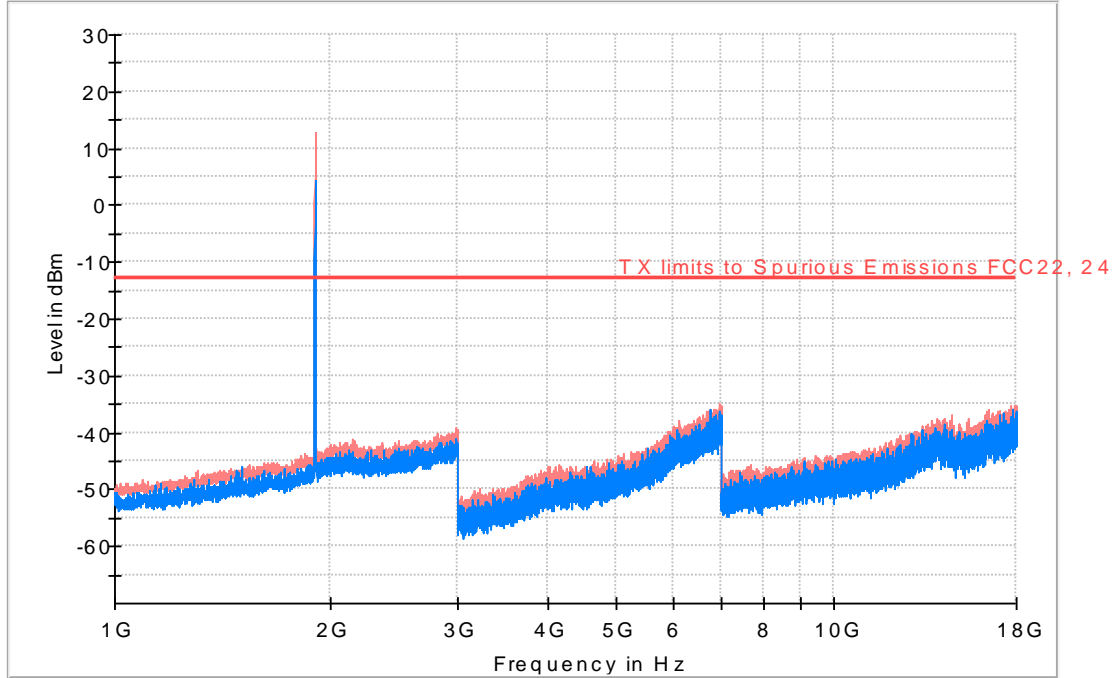

PK+_MAXH PK+_CLRWR TX limits to Spurious Emissions FCC22, 24

Frequency (MHz)	PK+_CLRWR (dBm)	PK+_MAXH (dBm)	Pol	Margin - PK+ (dB)	Limit - PK+ (dBm)	Comment
1900.000000	4.5	12.8	V	---	---	Uplink

TEST RESULTS (Cont.):

Highest Channel

FREQUENCY RANGE: 18-20 GHz

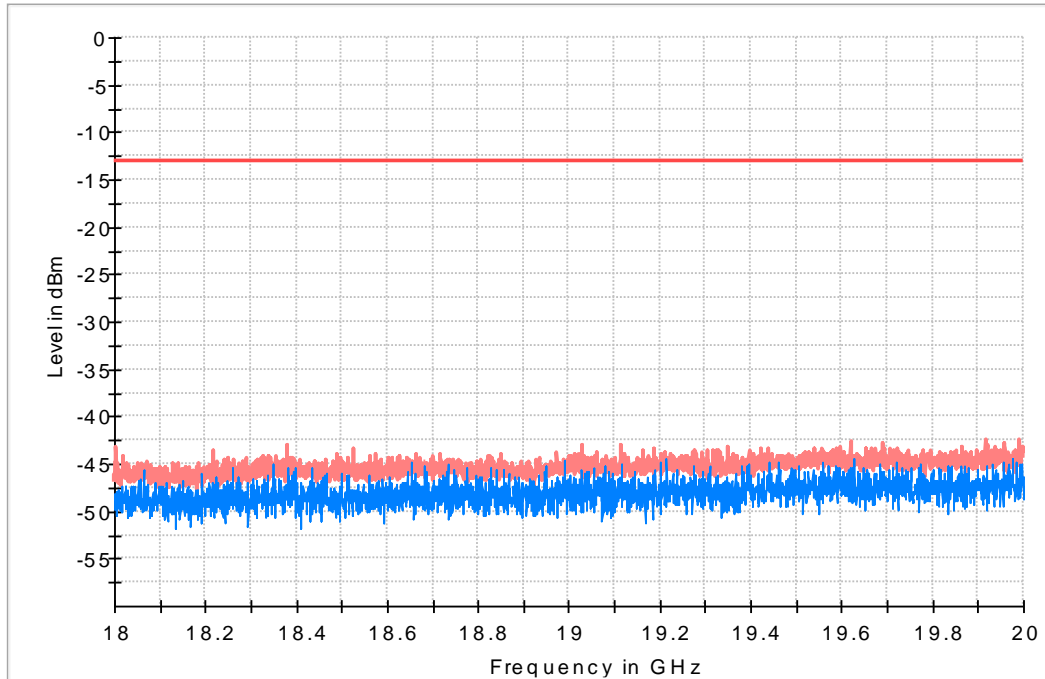

— PK+_MAXH — PK+_CLRWR — TX limits to Spurious Emissions FCC22, 24

Frequency (MHz)	PK+_CLRWR (dBm)	PK+_MAXH (dBm)	Pol	Margin - PK+ (dB)	Limit - PK+ (dBm)
19029.187500	-47.5	-43.0	V	30.0	-13.0

Appendix B: FCC 27 Results

Appendix B Content

DESCRIPTION OF TEST CONDITIONS	31
TEST B.1: RF OUTPUT POWER.....	33
TEST B.2: RADIATED EMISSIONS (PART 27)	39

DESCRIPTION OF TEST CONDITIONS

The worst case was found when positioned as the table below. Following channel(s) was (were) selected for the final test as listed below:

TEST CONDITIONS	DESCRIPTION										
<p>TC#01 LTE Band 12</p>	<p><u>Power supply (V):</u> $V_{\text{nominal}} = 13.8 \text{ Vdc}$</p> <p><u>Test Frequencies for Conducted tests:</u></p> <p><u>1.4 MHz Bandwidth:</u> -Lowest Channel: 23017(699.7 MHz) -Middle Channel: 23095(707.5 MHz) -Highest Channel: 23173(715.3 MHz)</p> <p><u>3 MHz Bandwidth:</u> -Lowest Channel: 23025(700.5 MHz) -Middle Channel: 23095(707.5 MHz) -Highest Channel: 23165(714.5 MHz)</p> <p><u>5 MHz Bandwidth:</u> -Lowest Channel: 23035(701.5 MHz) -Middle Channel: 23095(707.5 MHz) -Highest Channel: 23155(713.5 MHz)</p> <p><u>10 MHz Bandwidth:</u> -Lowest Channel: 23060(704 MHz) -Middle Channel: 23095(707.5 MHz) -Highest Channel: 23130(711 MHz)</p> <p><u>Test Frequencies for Radiated tests:</u></p> <table border="1" data-bbox="413 1588 1334 1794"> <thead> <tr> <th>Available Frequencies</th> <th>Tested Frequency</th> <th>Channel Bandwidth</th> <th>Modulation</th> <th>Mode</th> </tr> </thead> <tbody> <tr> <td>699 to 710 MHz</td> <td>700.5 MHz 707.5 MHz 714.5 MHz</td> <td>3 MHz</td> <td>QPSK</td> <td>1 RB</td> </tr> </tbody> </table> <p>Note: This device was tested under all bandwidths, RB configurations and modulations. The worst case found in QPSK modulation.</p>	Available Frequencies	Tested Frequency	Channel Bandwidth	Modulation	Mode	699 to 710 MHz	700.5 MHz 707.5 MHz 714.5 MHz	3 MHz	QPSK	1 RB
Available Frequencies	Tested Frequency	Channel Bandwidth	Modulation	Mode							
699 to 710 MHz	700.5 MHz 707.5 MHz 714.5 MHz	3 MHz	QPSK	1 RB							

TEST CONDITIONS	DESCRIPTION										
<p style="text-align: center;">TC#02 LTE Band 66</p>	<p><u>Power supply (V):</u> $V_{\text{nominal}} = 13.8 \text{ Vdc}$</p> <p><u>Test Frequencies for Conducted tests:</u></p> <p><u>1.4 MHz Bandwidth:</u> -Lowest Channel: 131979(1710.7 MHz) -Middle Channel: 132322(1745 MHz) -Highest Channel: 132665(1779.3 MHz)</p> <p><u>3 MHz Bandwidth:</u> -Lowest Channel: 131987(1711.5 MHz) -Middle Channel: 132322(1745 MHz) -Highest Channel: 132657(1778.5 MHz)</p> <p><u>5 MHz Bandwidth:</u> -Lowest Channel: 131997(1712.5 MHz) -Middle Channel: 132322(1745 MHz) -Highest Channel: 132647(1777.5 MHz)</p> <p><u>10 MHz Bandwidth:</u> -Lowest Channel: 132022(1715 MHz) -Middle Channel: 132322(1745 MHz) -Highest Channel: 132622(1775 MHz)</p> <p><u>15 MHz Bandwidth:</u> -Lowest Channel: 132047(1717.5 MHz) -Middle Channel: 132322(1745 MHz) -Highest Channel: 132597(1772.5 MHz)</p> <p><u>20 MHz Bandwidth:</u> -Lowest Channel: 132072(1720 MHz) -Middle Channel: 132322(1745 MHz) -Highest Channel: 132572(1770 MHz)</p> <p><u>Test Frequencies for Radiated tests:</u></p> <table border="1" data-bbox="402 1451 1323 1655"> <thead> <tr> <th>Available Frequencies</th> <th>Tested Frequency</th> <th>Channel Bandwidth</th> <th>Modulation</th> <th>Mode</th> </tr> </thead> <tbody> <tr> <td>1710 – 1780 MHz</td> <td>1711.5 MHz 1745 MHz 1778.5 MHz</td> <td>3 MHz</td> <td>QPSK</td> <td>1 RB</td> </tr> </tbody> </table> <p>Note: This device was tested under all bandwidths, RB configurations and modulations. The worst case found in QPSK modulation.</p>	Available Frequencies	Tested Frequency	Channel Bandwidth	Modulation	Mode	1710 – 1780 MHz	1711.5 MHz 1745 MHz 1778.5 MHz	3 MHz	QPSK	1 RB
Available Frequencies	Tested Frequency	Channel Bandwidth	Modulation	Mode							
1710 – 1780 MHz	1711.5 MHz 1745 MHz 1778.5 MHz	3 MHz	QPSK	1 RB							

TEST B.1: RF OUTPUT POWER

LIMITS:	Product standard:	FCC Part 27 / RSS-130/ RSS-139
	Test standard:	FCC §2.1046 and §27.50 / RSS-130 Clause 4.6/ RSS 139-Clause 6.5

LIMITS

The ERP of mobile transmitters and auxiliary test transmitters must not exceed 7 Watts.

RSS-132 Clause 5.4

The transmitter output power shall be measured in terms of average power. The equivalent isotropically radiated power (e.i.r.p.) for mobile equipment shall not exceed 11.5 watts. Refer to SRSP-503 for base station e.i.r.p. limits.

In addition, the peak-to-average power ratio (PAPR) of the transmitter shall not exceed 13 dB for more than 0.1% of the time using a signal corresponding to the highest PAPR during periods of continuous transmission.

TEST SETUP

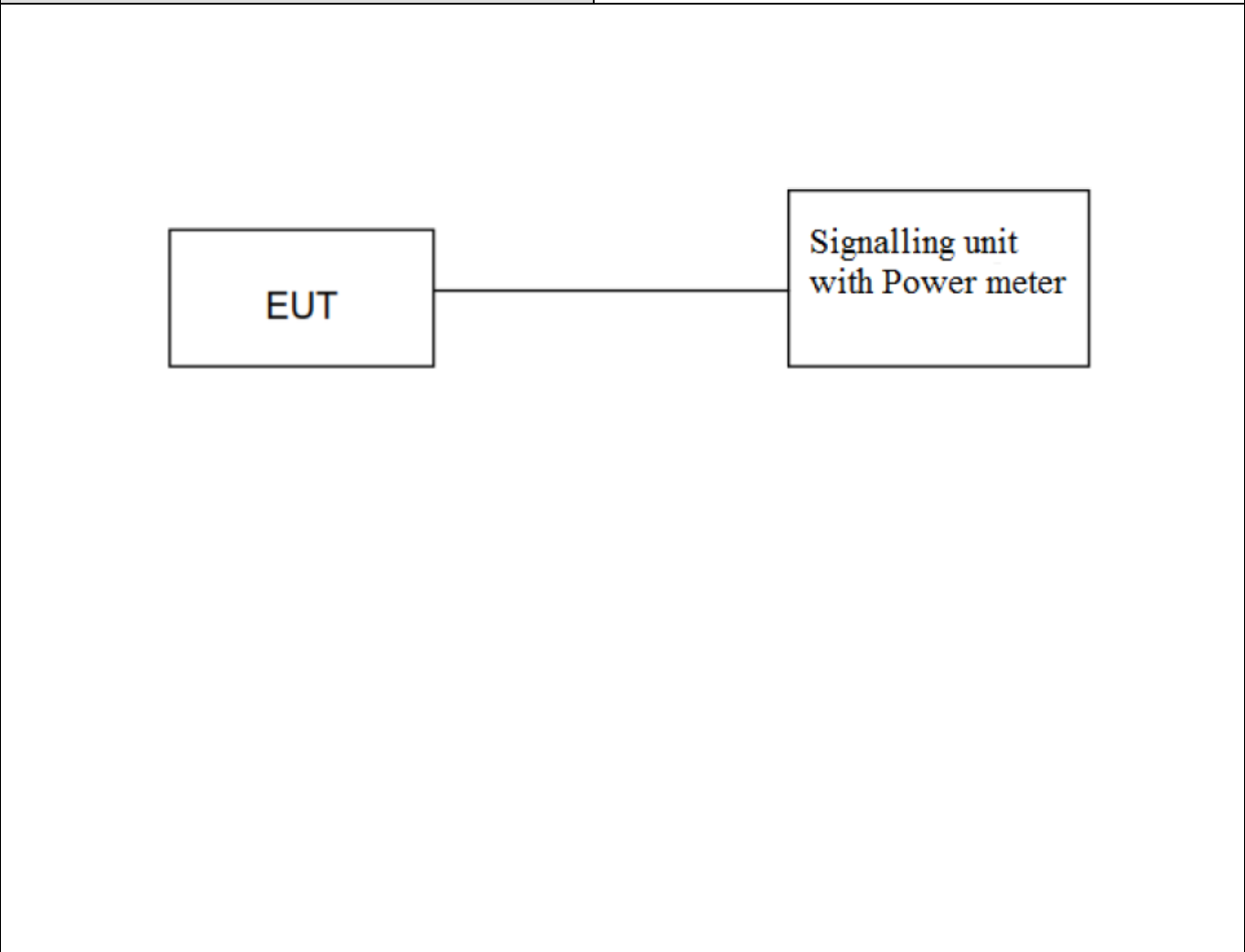

TESTED SAMPLES:	S/01
TESTED CONDITIONS MODES:	TC#01 (Band 12)
TEST RESULTS:	PASS

LTE QPSK MODULATION. Bandwidth = 1.4 MHz, RB: 1, Offset: 0

Channel	Average power at antenna port (dBm)	Maximum declared antenna gain (dBi)	Maximum E.I.R.P. average power (dBm)
Lowest	23.50	1.00	24.50
Middle	23.16	1.00	24.16
Highest	23.58	1.00	24.58

LTE 16QAM MODULATION. Bandwidth = 1.4 MHz, RB: 1, Offset: 0

Channel	Average power at antenna port (dBm)	Maximum declared antenna gain (dBi)	Maximum E.I.R.P. average power (dBm)
Lowest	21.96	1.00	22.96
Middle	22.54	1.00	23.54
Highest	22.82	1.00	23.82

LTE QPSK MODULATION. Bandwidth = 3 MHz, RB: 1, Offset: 7

Channel	Average power at antenna port (dBm)	Maximum declared antenna gain (dBi)	Maximum E.I.R.P. average power (dBm)
Lowest	23.62	1.00	24.62
Middle	23.46	1.00	24.46
Highest	23.70	1.00	24.70

LTE 16QAM MODULATION. Bandwidth = 3 MHz, RB: 1, Offset: 0

Channel	Average power at antenna port (dBm)	Maximum declared antenna gain (dBi)	Maximum E.I.R.P. average power (dBm)
Lowest	22.33	1.00	23.33
Middle	22.59	1.00	23.59
Highest	22.26	1.00	23.26

TEST RESULTS (Cont.):

LTE QPSK MODULATION. Bandwidth = 5 MHz, RB: 1, Offset: 0

Channel	Average power at antenna port (dBm)	Maximum declared antenna gain (dBi)	Maximum E.I.R.P. average power (dBm)
Lowest	23.13	1.00	24.13
Middle	22.68	1.00	23.68
Highest	22.71	1.00	23.71

LTE 16QAM MODULATION. Bandwidth = 5 MHz, RB: 1, Offset: 12

Channel	Average power at antenna port (dBm)	Maximum declared antenna gain (dBi)	Maximum E.I.R.P. average power (dBm)
Lowest	21.57	1.00	22.57
Middle	21.83	1.00	22.83
Highest	22.36	1.00	23.36

LTE QPSK MODULATION. Bandwidth = 10 MHz, RB: 1, Offset: 24

Channel	Average power at antenna port (dBm)	Maximum declared antenna gain (dBi)	Maximum E.I.R.P. average power (dBm)
Lowest	23.30	1.00	24.30
Middle	23.00	1.00	24.00
Highest	23.37	1.00	24.37

LTE 16QAM MODULATION. Bandwidth = 10 MHz, RB: 1, Offset: 24

Channel	Average power at antenna port (dBm)	Maximum declared antenna gain (dBi)	Maximum E.I.R.P. average power (dBm)
Lowest	22.45	1.00	23.45
Middle	22.28	1.00	23.28
Highest	22.80	1.00	23.80

TESTED SAMPLES:	S/01
TESTED CONDITIONS MODES:	TC#02 (Band 66)
TEST RESULTS:	PASS

LTE QPSK MODULATION. Bandwidth = 1.4 MHz, RB: 1, Offset: 0

Channel	Average power at antenna port (dBm)	Maximum declared antenna gain (dBi)	Maximum E.I.R.P. average power (dBm)
Lowest	22.22	6.20	28.42
Middle	23.07	6.20	29.27
Highest	23.03	6.20	29.23

LTE 16QAM MODULATION. Bandwidth = 1.4 MHz, RB: 1, Offset: 2

Channel	Average power at antenna port (dBm)	Maximum declared antenna gain (dBi)	Maximum E.I.R.P. average power (dBm)
Lowest	22.04	6.20	28.24
Middle	22.37	6.20	28.57
Highest	21.88	6.20	28.08

LTE QPSK MODULATION. Bandwidth = 3 MHz, RB: 1, Offset: 7

Channel	Average power at antenna port (dBm)	Maximum declared antenna gain (dBi)	Maximum E.I.R.P. average power (dBm)
Lowest	23.06	6.20	29.26
Middle	23.40	6.20	29.60
Highest	22.45	6.20	28.65

LTE 16QAM MODULATION. Bandwidth = 3 MHz, RB: 1, Offset: 0

Channel	Average power at antenna port (dBm)	Maximum declared antenna gain (dBi)	Maximum E.I.R.P. average power (dBm)
Lowest	22.84	6.20	29.04
Middle	22.98	6.20	29.18
Highest	22.30	6.20	28.50

TEST RESULTS (Cont.):

LTE QPSK MODULATION. Bandwidth = 5 MHz, RB: 1, Offset: 12

Channel	Average power at antenna port (dBm)	Maximum declared antenna gain (dBi)	Maximum E.I.R.P. average power (dBm)
Lowest	22.94	6.20	29.14
Middle	22.61	6.20	28.81
Highest	22.66	6.20	28.86

LTE 16QAM MODULATION. Bandwidth = 5 MHz, RB: 1, Offset: 12

Channel	Average power at antenna port (dBm)	Maximum declared antenna gain (dBi)	Maximum E.I.R.P. average power (dBm)
Lowest	22.84	6.20	29.04
Middle	22.98	6.20	29.18
Highest	22.50	6.20	28.70

LTE QPSK MODULATION. Bandwidth = 10 MHz, RB: 1, Offset: 0

Channel	Average power at antenna port (dBm)	Maximum declared antenna gain (dBi)	Maximum E.I.R.P. average power (dBm)
Lowest	22.65	6.20	28.85
Middle	23.15	6.20	29.35
Highest	22.79	6.20	28.99

LTE 16QAM MODULATION. Bandwidth = 10 MHz, RB: 1, Offset: 0

Channel	Average power at antenna port (dBm)	Maximum declared antenna gain (dBi)	Maximum E.I.R.P. average power (dBm)
Lowest	22.14	6.20	28.34
Middle	22.55	6.20	28.75
Highest	22.16	6.20	28.36

TEST RESULTS (Cont.):

LTE QPSK MODULATION. Bandwidth = 15 MHz, RB: 1, Offset: 74

Channel	Average power at antenna port (dBm)	Maximum declared antenna gain (dBi)	Maximum E.I.R.P. average power (dBm)
Lowest	23.28	6.20	29.48
Middle	22.88	6.20	29.08
Highest	22.96	6.20	29.16

LTE 16QAM MODULATION. Bandwidth = 15 MHz, RB: 1, Offset: 37

Channel	Average power at antenna port (dBm)	Maximum declared antenna gain (dBi)	Maximum E.I.R.P. average power (dBm)
Lowest	22.94	6.20	29.14
Middle	22.74	6.20	28.94
Highest	22.51	6.20	28.71

LTE QPSK MODULATION. Bandwidth = 20 MHz, RB: 1, Offset: 49

Channel	Average power at antenna port (dBm)	Maximum declared antenna gain (dBi)	Maximum E.I.R.P. average power (dBm)
Lowest	23.10	6.20	29.30
Middle	22.88	6.20	29.08
Highest	22.49	6.20	28.69

LTE 16QAM MODULATION. Bandwidth = 20 MHz, RB: 1, Offset: 0

Channel	Average power at antenna port (dBm)	Maximum declared antenna gain (dBi)	Maximum E.I.R.P. average power (dBm)
Lowest	22.22	6.20	28.42
Middle	21.94	6.20	28.14
Highest	21.82	6.20	28.02

TEST B.2: RADIATED EMISSIONS (PART 27)

LIMITS:	Product standard :	FCC Part 27
	Test standard :	FCC §2.1051 and §27.53(g) (h)

LIMITS

According to specification. the power of emissions shall be attenuated below the transmitter power (P) by a factor of at least $43 + 10 \log (P)$ dB. P in watts.

At P_o transmitting power. the specified minimum attenuation becomes $43+10\log (P_o)$. and the level in dBm relative P_o becomes:

$$P_o \text{ (dBm)} - [43 + 10 \log (P_o \text{ in mwatts}) - 30] = -13 \text{ dBm}$$

TEST SETUP

The measurement was performed with the EUT inside an anechoic chamber. The spectrum was scanned from 30 MHz to at least the 10th harmonic of the highest frequency generated within the equipment.

The EUT was placed on a non-conductive stand at a 3-meter distance from the measuring antenna for measurements up to 18 GHz and at 1 m distance for measurements above 18 GHz.

Detected emissions were maximized at each frequency by rotating the EUT and adjusting the measuring antenna height and polarization. The maximum meter reading was recorded.

Radiated measurements < 1 GHz

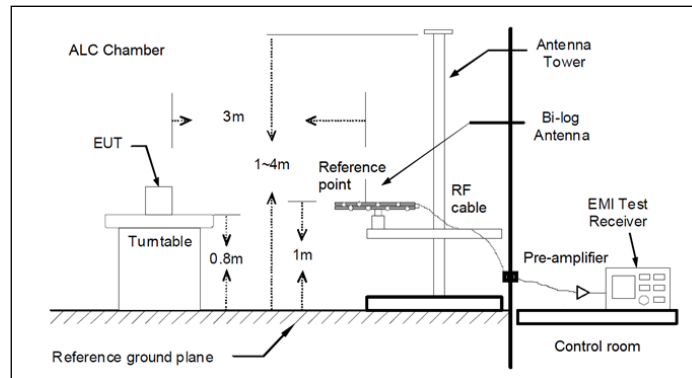

TEST SETUP

Continued

Radiated measurements < 18 GHz

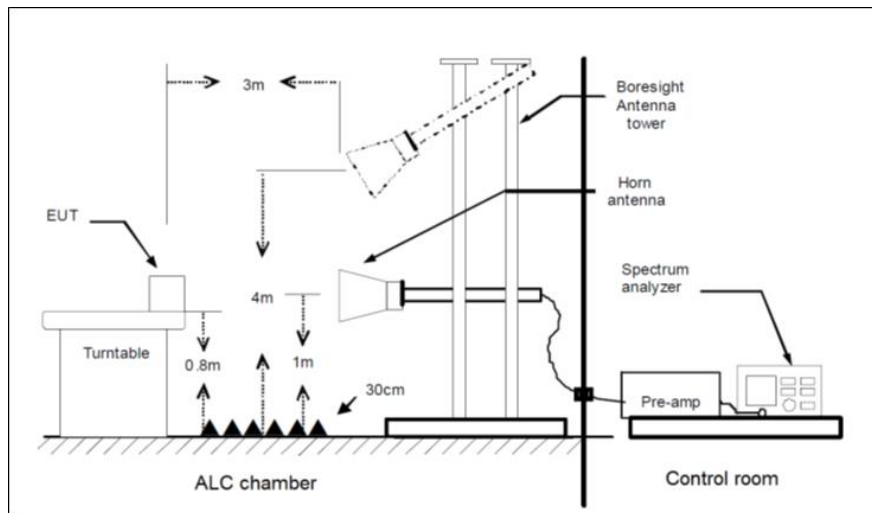

Radiated measurements > 18 GHz

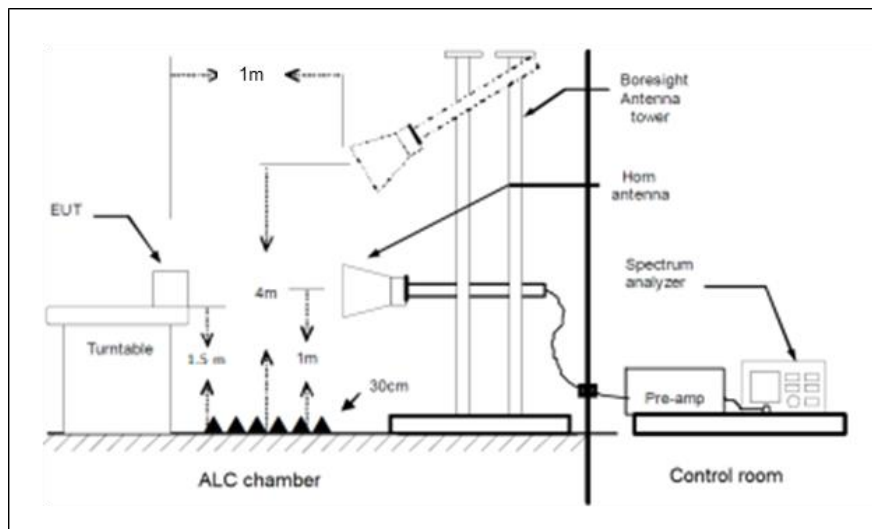

TESTED SAMPLES:	S/02
TESTED CONDITIONS MODES:	TC#01 (Band 12)
TEST RESULTS:	PASS

RESULTS

A preliminary scan determined the QPSK 20 MHz bandwidth and a single RB configuration as the worst case based on the conducted RF output power test.

The following plots show the results for this configuration.

LTE QPSK MODULATION. RB = 1. Offset = 7. BW = 3 MHz

TEST RESULTS (Cont.):	Lowest Channel
------------------------------	----------------

FREQUENCY RANGE: 30-1000 MHz

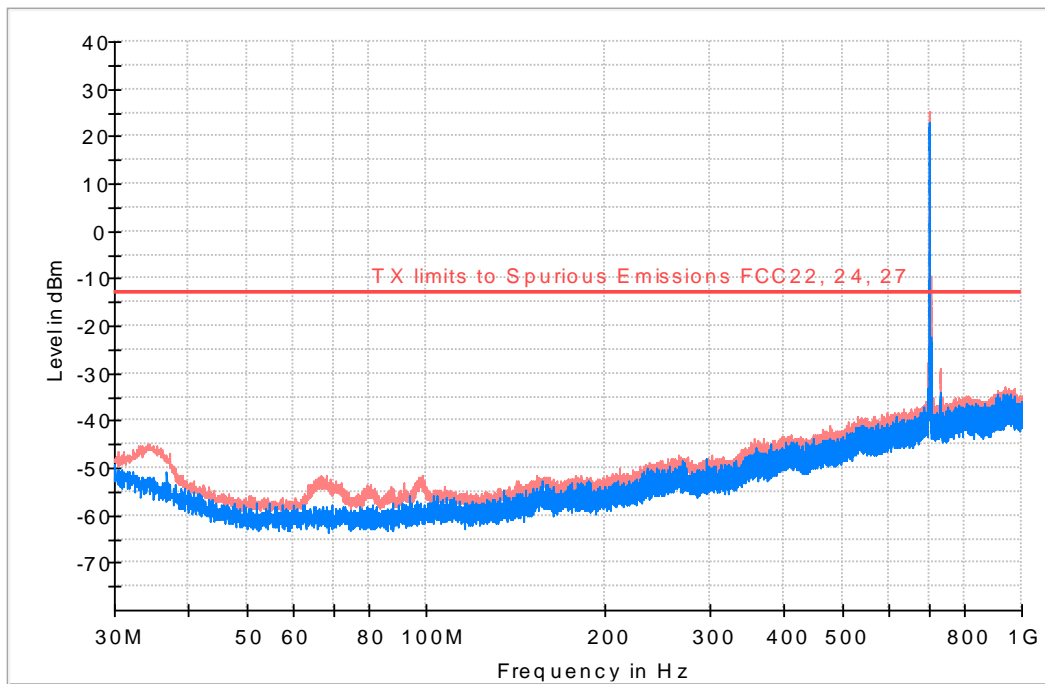

— PK+_MAXH — PK+_CLRWR — TX limits to Spurious Emissions FCC22, 24

Frequency (MHz)	PK+_CLRWR (dBm)	PK+_MAXH (dBm)	Pol	Margin - PK+ (dB)	Limit - PK+ (dBm)	Comment
700.755000	19.5	25.4	V	---	---	Uplink
730.275333	-41.9	-29.1	H	---	---	Downlink

TEST RESULTS (Cont.):

Lowest Channel

FREQUENCY RANGE: 1-18 GHz

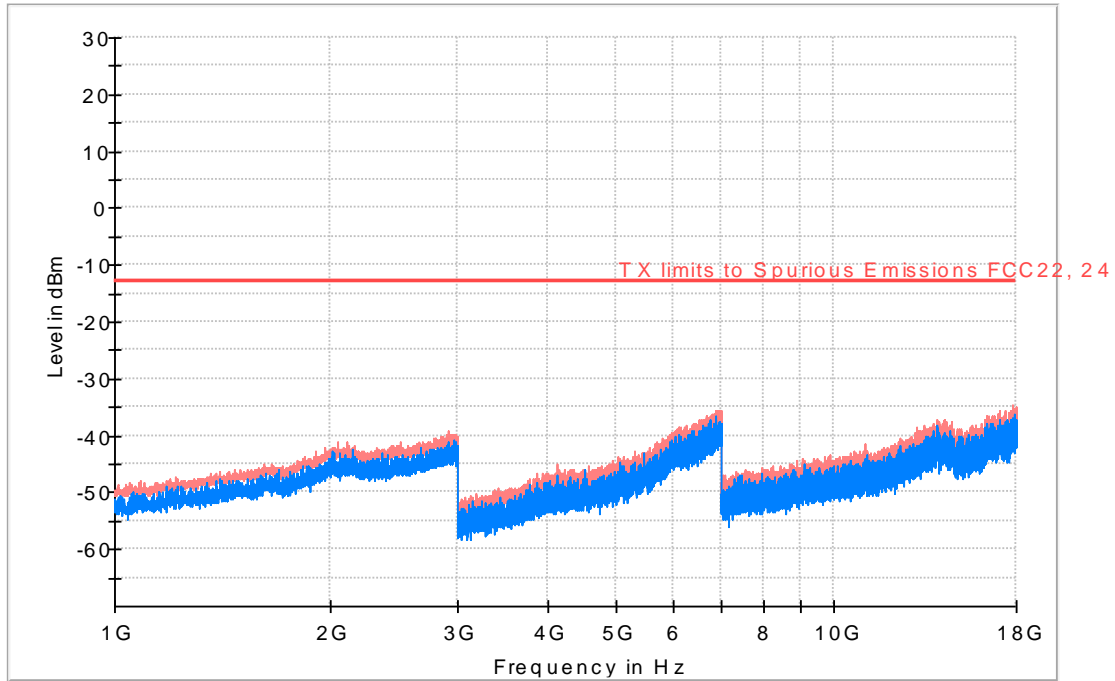

— PK+_MAXH — PK+_CLRWR — TX limits to Spurious Emissions FCC22, 24

Frequency (MHz)	PK+_CLRWR (dBm)	PK+_MAXH (dBm)	Pol	Margin - PK+ (dB)	Limit - PK+ (dBm)
6987.000000	-41.3	-35.5	H	22.5	-13.0

TEST RESULTS (Cont.):

Middle Channel

FREQUENCY RANGE: 30MHz-1 GHz

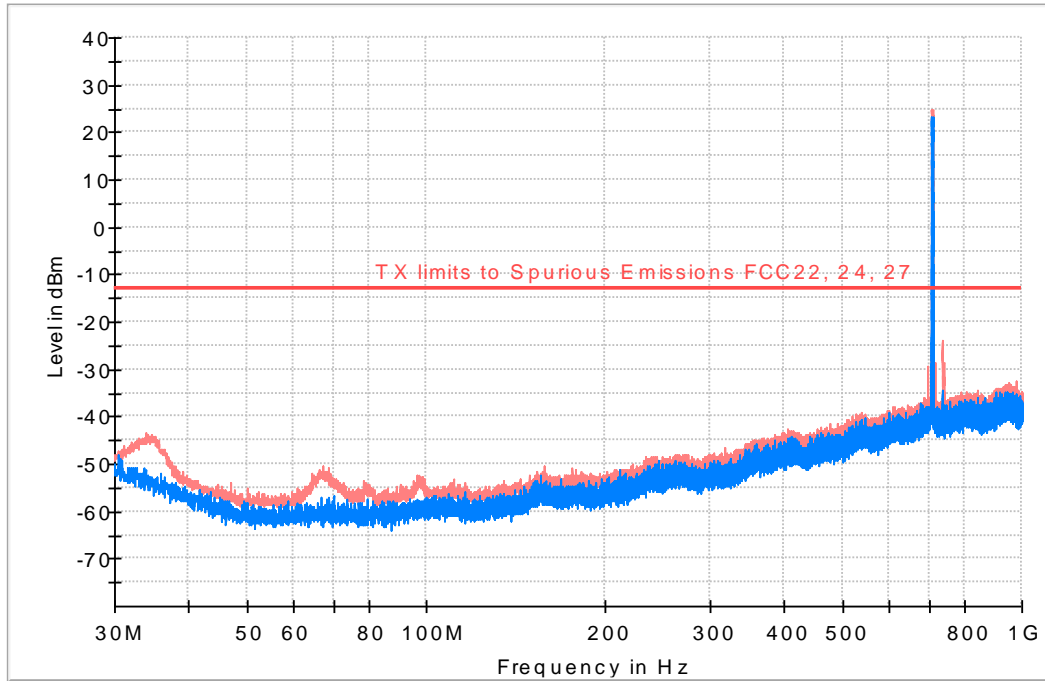

PK+_MAXH PK+_CLRWR TX limits to Spurious Emissions FCC22, 24

Frequency (MHz)	PK+_CLRWR (dBm)	PK+_MAXH (dBm)	PoI	Margin - PK+ (dB)	Limit - PK+ (dBm)	Comment
707.771333	22.7	24.9	V	---	---	Uplink
737.615000	-41.4	-24.0	V	---	---	Downlink

TEST RESULTS (Cont.):

Middle Channel

FREQUENCY RANGE: 1-18 GHz

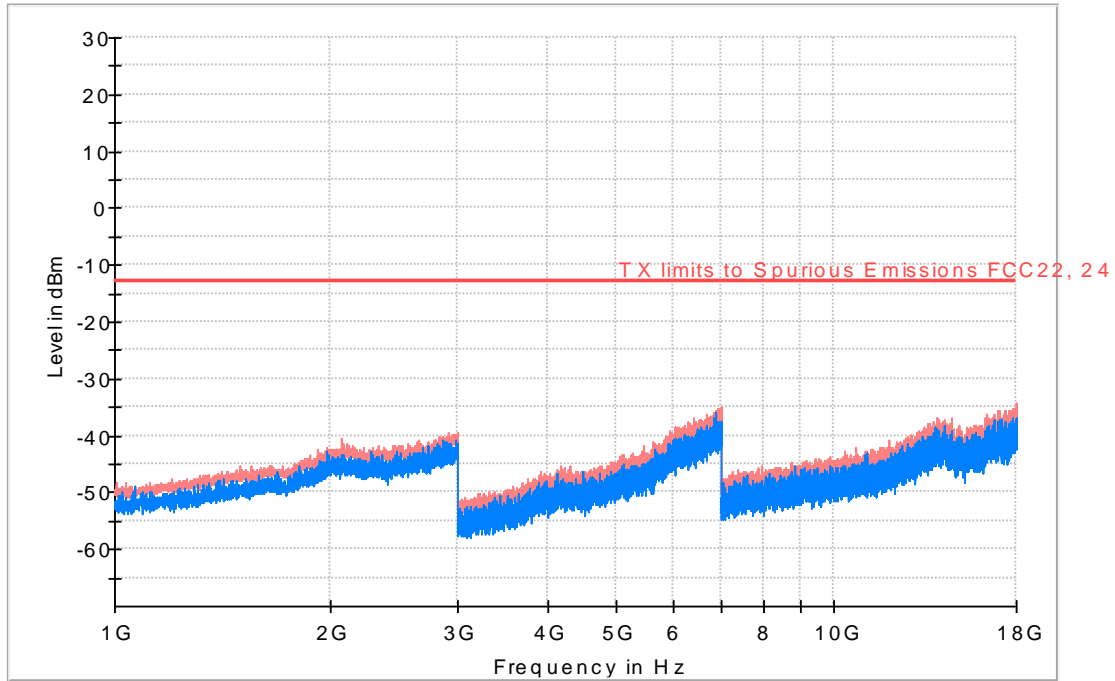

— PK+_MAXH — PK+_CLRWR — TX limits to Spurious Emissions FCC22, 24

Frequency (MHz)	PK+_CLRWR (dBm)	PK+_MAXH (dBm)	Pol	Margin - PK+ (dB)	Limit - PK+ (dBm)
6996.000000	-38.4	-35.0	H	22.0	-13.0

TEST RESULTS (Cont.):

Highest Channel

FREQUENCY RANGE: 30 MHz-1 GHz

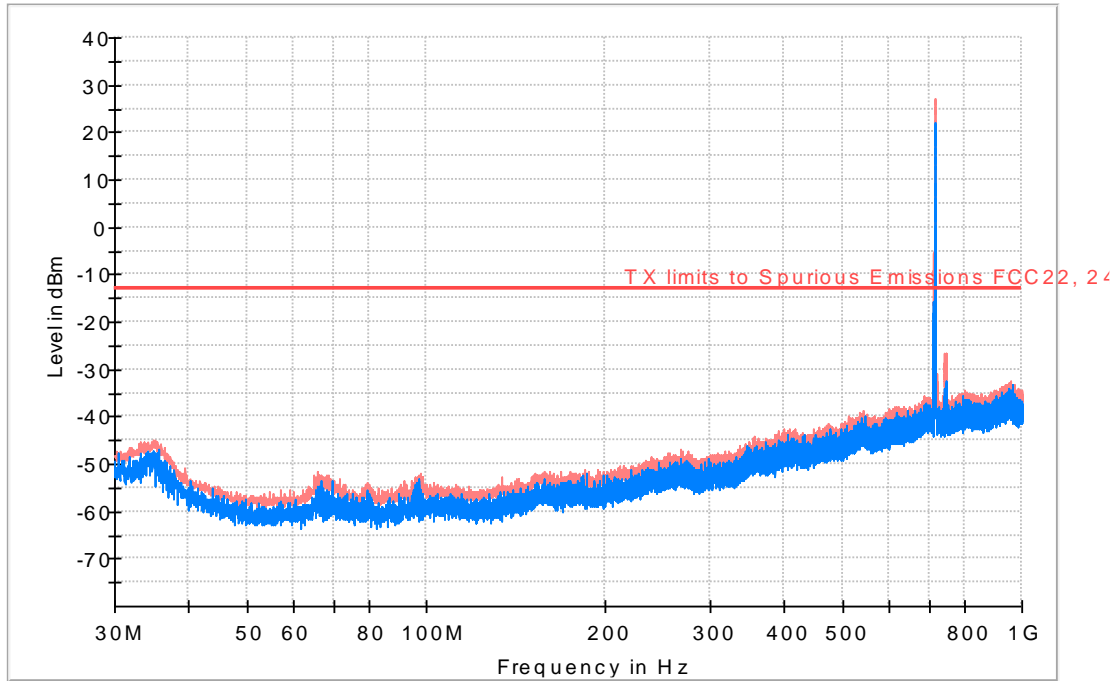

— PK+_MAXH — PK+_CLRWR — TX limits to Spurious Emissions FCC22, 24

Frequency (MHz)	PK+_CLRWR (dBm)	PK+_MAXH (dBm)	Pol	Margin - PK+ (dB)	Limit - PK+ (dBm)	Comment
714.658333	21.0	27.0	V	---	---	Uplink
744.696000	-41.4	-26.7	H	---	---	Downlink

TEST RESULTS (Cont.):

Highest Channel

FREQUENCY RANGE: 1-18 GHz

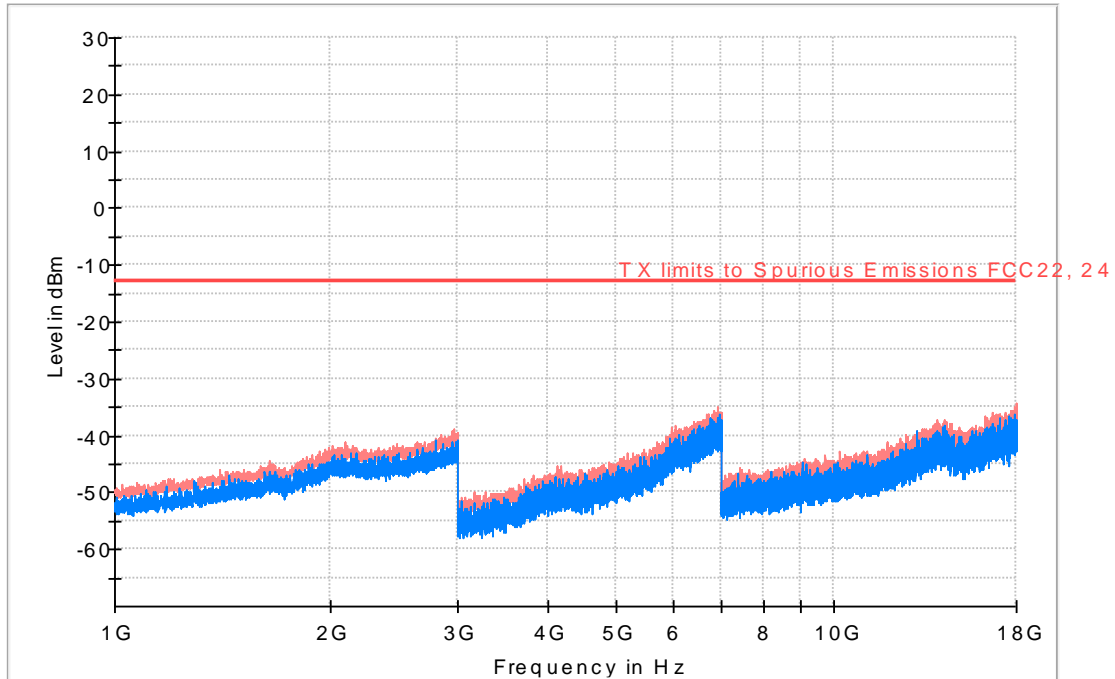

— PK+_MAXH — PK+_CLRWR — TX limits to Spurious Emissions FCC22, 24

Frequency (MHz)	PK+_CLRWR (dBm)	PK+_MAXH (dBm)	Pol	Margin - PK+ (dB)	Limit - PK+ (dBm)
6912.000000	-39.4	-35.0	V	22.0	-13.0

TESTED SAMPLES:	S/02
TESTED CONDITIONS MODES:	TC#02 (Band 66)
TEST RESULTS:	PASS

RESULTS

A preliminary scan determined the QPSK 20 MHz bandwidth and a single RB configuration as the worst case based on the conducted RF output power test.

The following plots show the results for this configuration.

LTE QPSK MODULATION. RB = 1. Offset = 7. BW = 3 MHz

TEST RESULTS (Cont.):	Lowest Channel
------------------------------	----------------

FREQUENCY RANGE: 30-1000 MHz

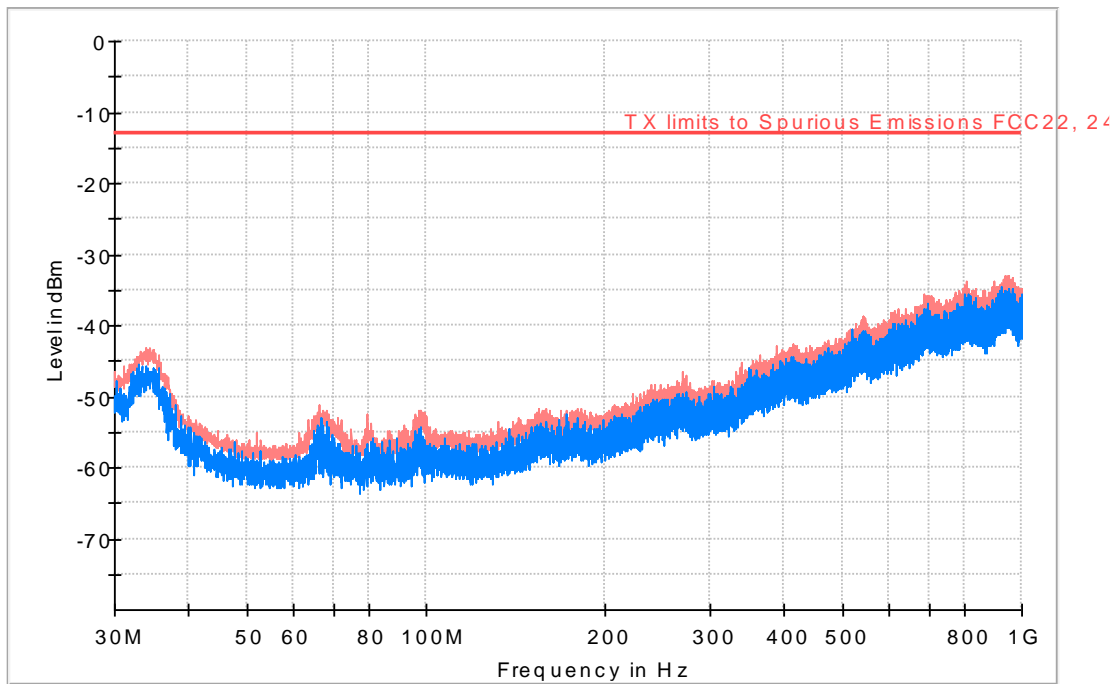

— PK+_MAXH — PK+_CLRWR — TX limits to Spurious Emissions FCC22, 24

Frequency (MHz)	PK+_CLRWR (dBm)	PK+_MAXH (dBm)	Pol	Margin - PK+ (dB)	Limit - PK+ (dBm)
34.462000	-46.7	-43.1	V	33.7	-13.0
947.943333	-39.1	-32.9	V	26.1	-13.0

TEST RESULTS (Cont.):

Lowest Channel

FREQUENCY RANGE: 1-18 GHz

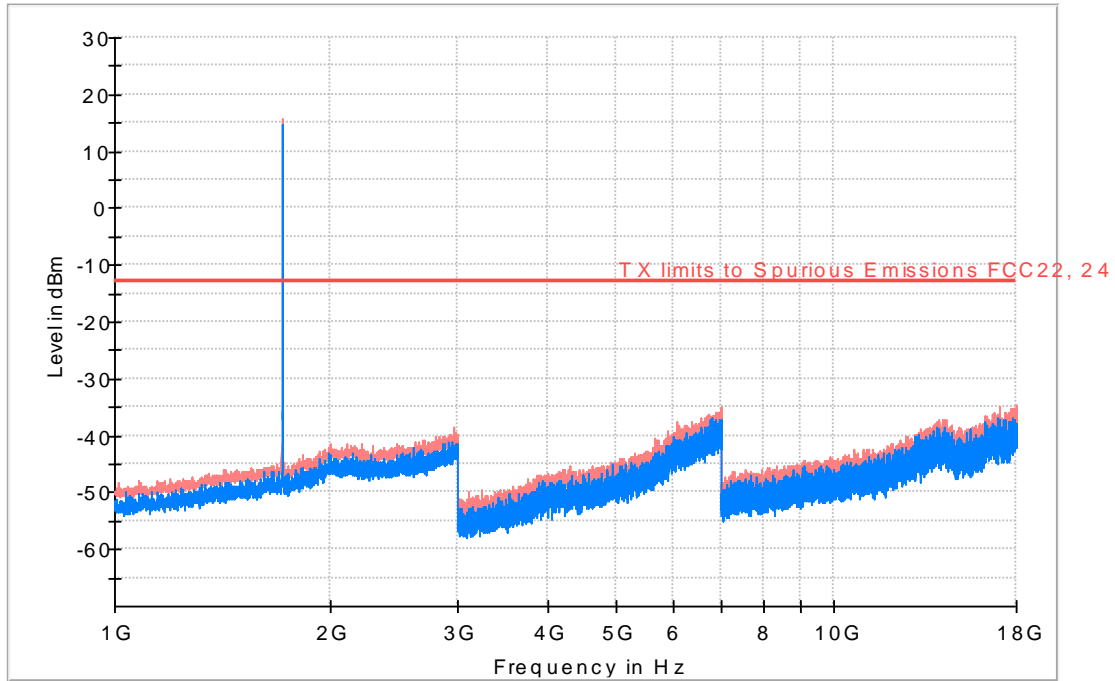

— PK+_MAXH — PK+_CLRWR — TX limits to Spurious Emissions FCC22, 24

Frequency (MHz)	PK+_CLRWR (dBm)	PK+_MAXH (dBm)	Pol	Margin - PK+ (dB)	Limit - PK+ (dBm)	Comment
1711.500000	14.8	15.8	V	---	---	Uplink

TEST RESULTS (Cont.):

Middle Channel

FREQUENCY RANGE: 30MHz-1 GHz

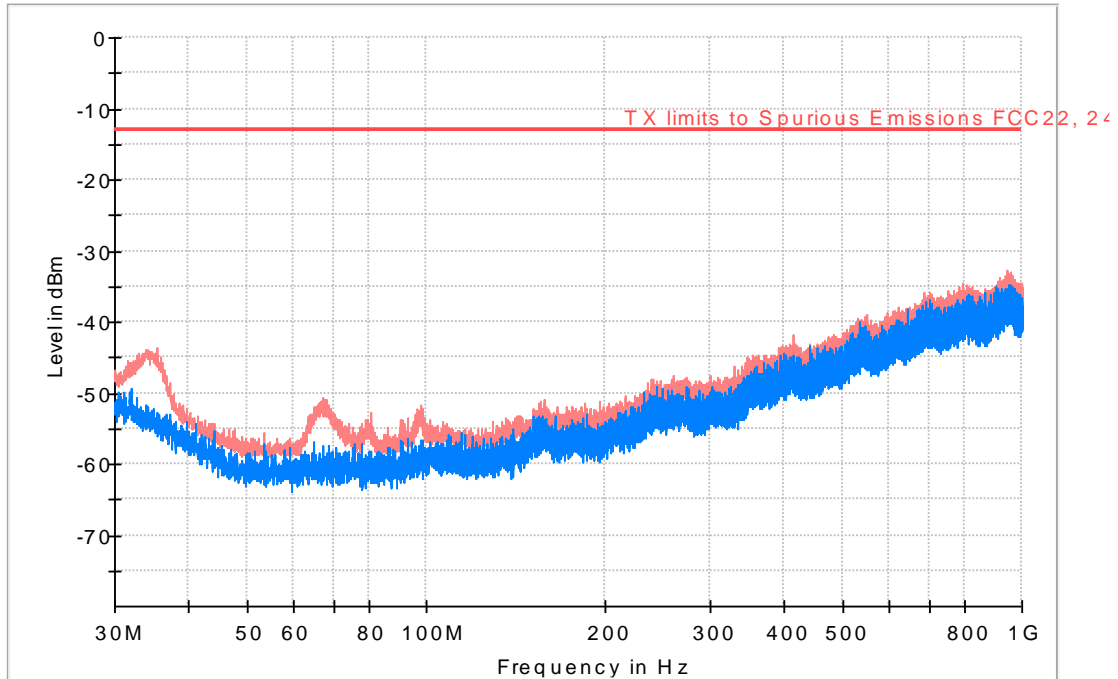

— PK+_MAXH — PK+_CLRWR — TX limits to Spurious Emissions FCC22, 24

Frequency (MHz)	PK+_CLRWR (dBm)	PK+_MAXH (dBm)	Pol	Margin - PK+ (dB)	Limit - PK+ (dBm)
35.302667	-54.2	-43.7	V	30.7	-13.0
945.874000	-37.0	-32.8	V	19.8	-13.0

TEST RESULTS (Cont.):

Middle Channel

FREQUENCY RANGE: 1-18 GHz

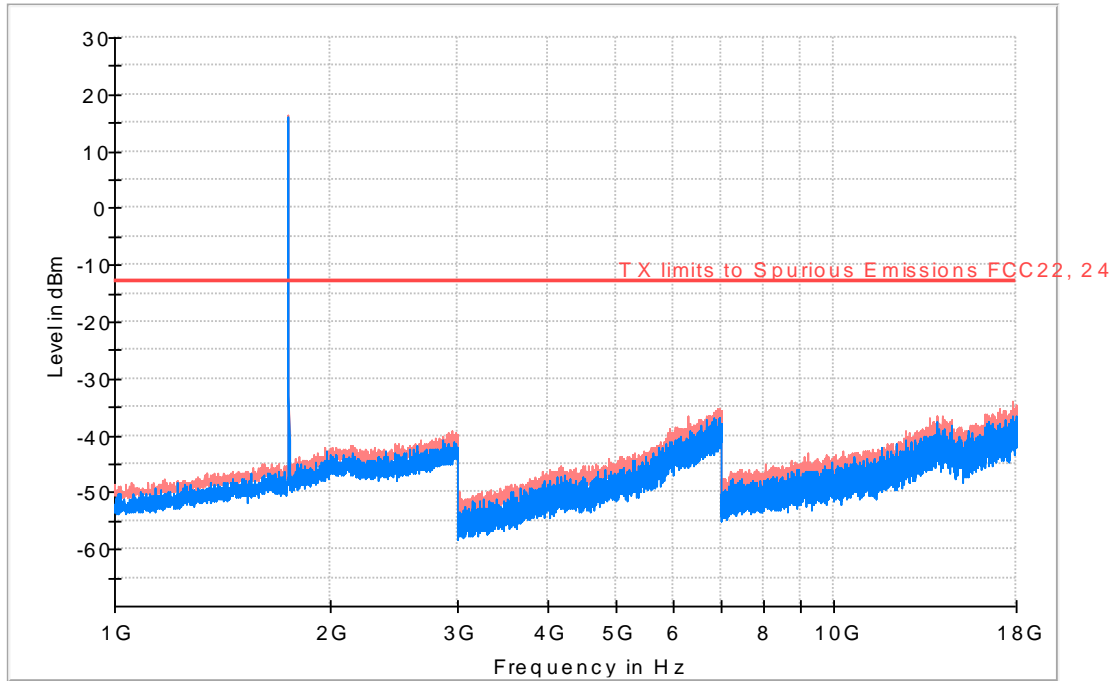

PK+_MAXH PK+_CLRWR TX limits to Spurious Emissions FCC22, 24

Frequency (MHz)	PK+_CLRWR (dBm)	PK+_MAXH (dBm)	Pol	Margin - PK+ (dB)	Limit - PK+ (dBm)	Comment
1745.000000	16.0	16.3	V	---	---	Uplink

TEST RESULTS (Cont.):

Highest Channel

FREQUENCY RANGE: 30 MHz-1 GHz

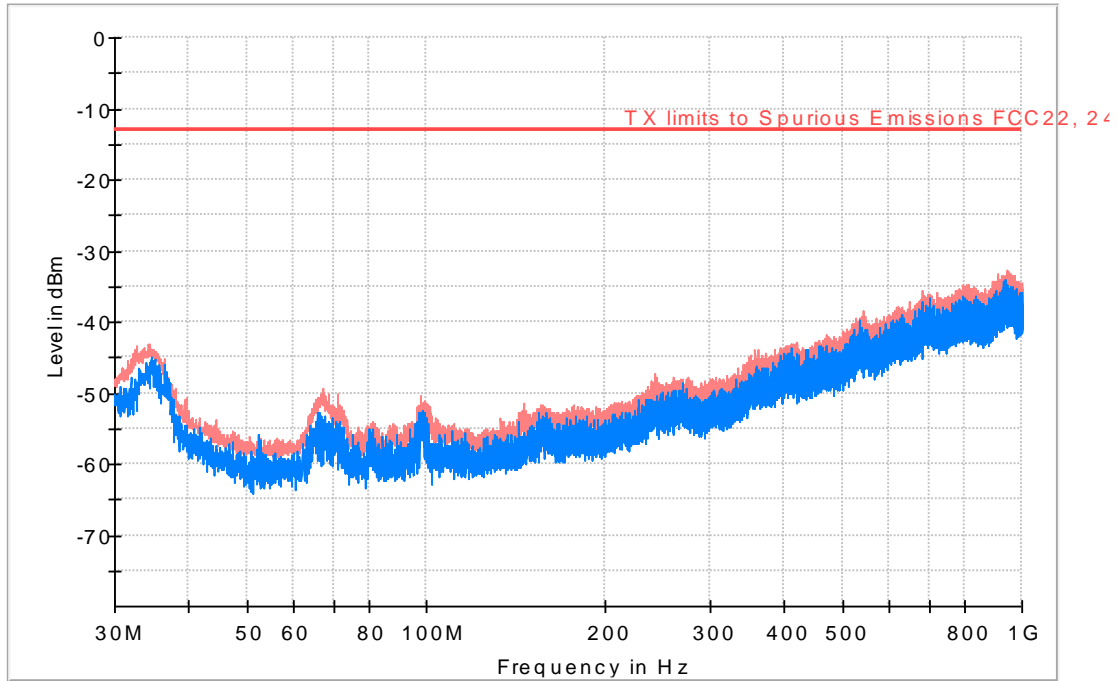

— PK+_MAXH — PK+_CLRWR — TX limits to Spurious Emissions FCC22, 24

Frequency (MHz)	PK+_CLRWR (dBm)	PK+_MAXH (dBm)	Pol	Margin - PK+ (dB)	Limit - PK+ (dBm)
34.365000	-47.3	-43.1	V	30.1	-13.0
945.356667	-38.0	-32.7	H	25.0	-13.0

TEST RESULTS (Cont.):

Highest Channel

FREQUENCY RANGE: 1-18 GHz

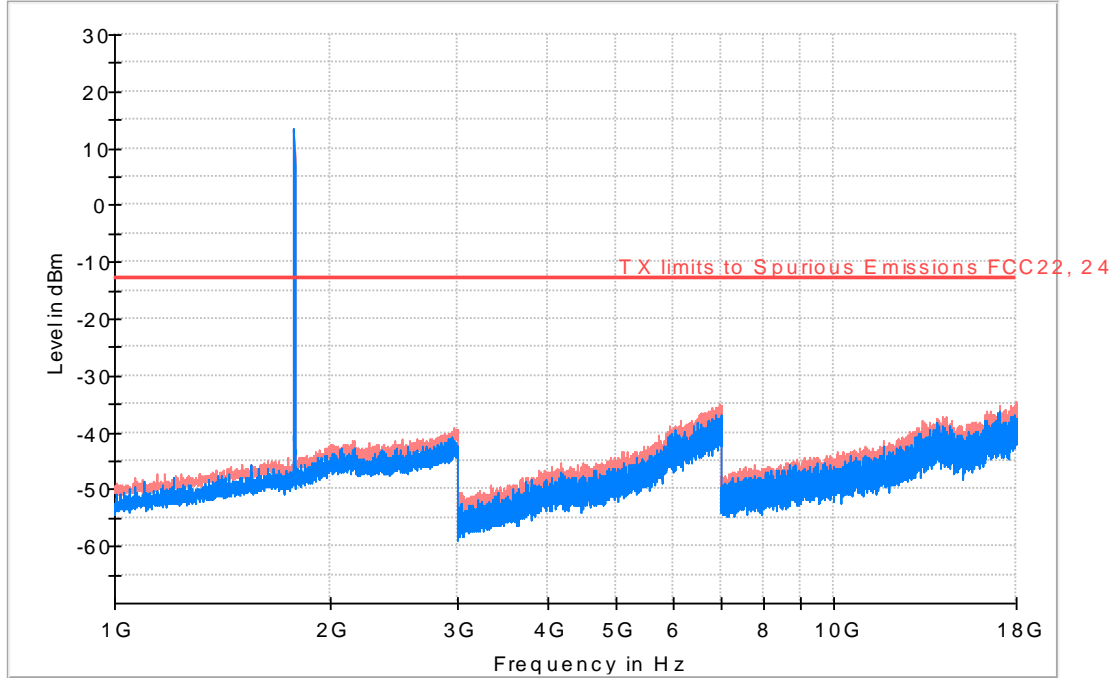

— PK+_MAXH — PK+_CLRWR — TX limits to Spurious Emissions FCC22, 24

Frequency (MHz)	PK+_CLRWR (dBm)	PK+_MAXH (dBm)	Poi	Margin - PK+ (dB)	Limit - PK+ (dBm)	Comment
1778.500000	13.4	13.4	V	---	---	Uplink