

# FCC Part 22H&24E Test Report

Product Name : 3G Cellular Alarm Communicator  
Trade Name : DSC  
Model No. : 3G9080  
FCC ID : F53173G9080  
IC : 160A-3G9080

Applicant : DIGITAL SECURITY CONTROLS, A DIV. OF TYCO  
SAFETY PRODUCTS CANAD LTD.

Address : 3301 Langstaff Rd., Concord, ON L4K4L2 Canada

Date of Receipt : May 16, 2017  
Issued Date : Jun. 06, 2017  
Report No. : 1750379R-HPUSP17V00  
Report Version : V4.0



The test results relate only to the samples tested.  
The test report shall not be reproduced except in full without the written approval of DEKRA Testing and Certification Co., Ltd..

# Test Report Certification

Issued Date : Jun. 06, 2017

Report No. : 1750379R-HPUSP17V00



Product Name : 3G Cellular Alarm Communicator  
 Applicant : DIGITAL SECURITY CONTROLS, A DIV. OF TYCO SAFETY PRODUCTS CANAD LTD.  
 Address : 3301 Langstaff Rd., Concord, ON L4K4L2 Canada  
 Manufacturer : DIGITAL SECURITY CONTROLS, A DIV. OF TYCO SAFETY PRODUCTS CANAD LTD.  
 Address : 3301 Langstaff Rd., Concord, ON L4K4L2 Canada  
 Model No. : 3G9080  
 FCC ID : F53173G9080  
 IC : 160A-3G9080  
 EUT Voltage : DC 24V  
 Testing Voltage : DC 24V  
 Trade Name : DSC  
 Applicable Standard : FCC CFR Title 47 Part 2, ANSI/TIA-603-D  
 FCC Part 22 Subpart H, FCC Part 24 Subpart E  
 Industry Canada RSS-132, Issue 3  
 Industry Canada RSS-133, Issue 6  
 ANSI/TIA-603-D-2010  
 RSS Gen Issue 4  
 Laboratory Name : Hsin Chu Laboratory  
 Address : No. 75-2, 3rd Lin, WangYe Keng, Yonghxing Tsuen, Qionglin Shiang, Hsinchu County 307, Taiwan (R.O.C.)  
 TEL: +886-3-592-8858 / FAX: +886-3-592-8859  
 Test Result : Complied

Documented By : Lyla Yang  
 ( Lyla Yang / Engineering Adm. Assistant )

Tested By : Max Chang  
 ( Max Chang / Engineer )

Approved By : Roy Wang  
 ( Roy Wang / Director )

## Laboratory Information

We, **DEKRA Testing and Certification Co., Ltd.**, are an independent RF consultancy that was established the whole facility in our laboratories. The test facility has been accredited/accepted (audited or listed) by the following related bodies in compliance with ISO 17025 specified testing scopes:

<b>Taiwan R.O.C.</b>	<b>:</b>	<b>TAF, Accreditation Number: 3024</b>
<b>USA</b>	<b>:</b>	<b>FCC, Registration Number: 834100</b>
<b>Canada</b>	<b>:</b>	<b>IC, Submission No: 181665</b> <b>IC Registration Number: 22397-1 / 22397-2 / 22397-3</b>

The related certificate for our laboratories about the test site and management system can be downloaded from DEKRA Testing and Certification Co., Ltd. Web Site:

<http://www.dekra.com.tw/english/about/certificates.aspx?bval=5>

The address and introduction of DEKRA Testing and Certification Co., Ltd. laboratories can be founded in our Web site : [http://www.dekra.com.tw/index\\_en.aspx](http://www.dekra.com.tw/index_en.aspx)

If you have any comments, Please don't hesitate to contact us. Our test sites as below:

- 1 No. 75-2, 3rd Lin, WangYe Keng, Yonghxing Tsuen, Qionglin Shiang, Hsinchu County 307, Taiwan (R.O.C.)  
TEL:+886-3-592-8858 / FAX:+886-3-592-8859 E-Mail : [info.tw@dekra.com](mailto:info.tw@dekra.com)
- 2 No.372, Sec. 4, Zhongxing Rd., Zhudong Township, Hsinchu County 31061, Taiwan  
TEL: +886-3-582-8001 / FAX: +886-3-582-8958 E-Mail : [info.tw@dekra.com](mailto:info.tw@dekra.com)
- 3 No.372-2, Sec. 4, Zhongxing Rd., Zhudong Township, Hsinchu County 31061, Taiwan  
TEL: +886-3-582-8001 / FAX: +886-3-582-8958 E-Mail : [info.tw@dekra.com](mailto:info.tw@dekra.com)

## TABLE OF CONTENTS

Description	Page
1. General Information.....	7
1.1. EUT Description .....	7
1.2. Mode of Operation.....	8
1.3. Tested System Details .....	9
1.4. Configuration of Tested System.....	9
1.5. EUT Exercise Software.....	9
2. Technical Test .....	10
2.1. Summary of Test Result.....	10
2.2. Test Environment.....	11
3. Maximum Output Power and Effective Isotropic Radiated Power Measurement.....	12
3.1. Test Equipment.....	12
3.2. Test Setup.....	12
3.3. Test Procedure .....	13
3.4. Uncertainty .....	13
3.5. Test Result.....	14
4. Occupied Bandwidth.....	24
4.1. Test Equipment.....	24
4.2. Test Setup.....	24
4.3. Test Procedure .....	24
4.4. Uncertainty .....	24
4.5. Test Result.....	25
5. Spurious Emission At Antenna Terminals (+/- 1MHz).....	65
5.1. Test Equipment.....	65
5.2. Test Setup.....	65
5.3. Test Procedure .....	65
5.4. Uncertainty .....	65
5.5. Test Result.....	66
6. Spurious Emission .....	76
6.1. Test Equipment.....	76
6.2. Test Setup.....	76
6.3. Test Procedure .....	78
6.4. Uncertainty .....	78
6.5. Test Result.....	79
7. Frequency Stability Under Temperature & Voltage Variations.....	159
7.1. Test Equipment.....	159

---

7.2. Test Setup.....	159
7.3. Test Procedure .....	160
7.4. Uncertainty .....	160
7.5. Test Result.....	161
Attachment 1.....	173
Test Setup Photograph .....	173
Attachment 2.....	176
EUT External Photograph.....	176
Attachment 3.....	179
EUT Internal Photograph .....	179

**Revision History**

<b>Report No.</b>	<b>Version</b>	<b>Description</b>	<b>Issued Date</b>
1750379R-HPUSP17V00	V4.0	Initial issue of report	Jun. 06, 2017

## 1. General Information

### 1.1. EUT Description

Product Name	3G Cellular Alarm Communicator
Model No.	3G9080
Trade Name	DSC
Tx Frequency Range/ Channel number	GSM 850: 824.2-848.8 MHz GSM 1900: 1850.2-1909.8 MHz WCDMA Band 2: 1852.4-1907.6 MHz WCDMA Band 5: 826.4-846.6 MHz
Rx Frequency Range/ Channel number	GSM 850: 869.2-893.8 MHz GSM 1900: 1930.2-1989.8 MHz WCDMA Band 2: 1932.4-1987.6 MHz WCDMA Band 5: 871.4-891.6 MHz
Type of Modulation	GPRS: GMSK; EGPRS: GMSK / 8PSK WCDMA: QPSK (Uplink); HSDPA: QPSK (Uplink)
HW Version	V1.0
SW Version	UA716 Rev.02
IMEI No.	352431086949279

Antenna Information	
Product Name/Model No.	AnteTec Technologies/ 1010250805
Antenna Type	Dipole Antenna
Antenna Gain	850MHz: 1.53 dBi 1900MHz: 2.07 dBi

**Note:**

This 3G Cellular Alarm Communicator included GSM 850, DCS 1900, WCDMA Band 2 and WCDMA Band 5 transmitting and receiving function.

## 1.2. Mode of Operation

DEKRA has verified the construction and function in typical operation. All the test modes were carried out with the EUT in normal operation, which was shown in this test report and defined as:

Test Mode
Mode 1: GPRS 850_Link
Mode 2: GPRS 1900_Link
Mode 3: EGPRS 850_Link
Mode 4: EGPRS 1900_Link
Mode 5: WCDMA Band 5_Link
Mode 6: WCDMA Band 5_HSUPA_Link
Mode 7: WCDMA Band 5_HSDPA_Link
Mode 8: WCDMA Band 2_Link
Mode 9: WCDMA Band 2_HSUPA_Link
Mode 10: WCDMA Band 2_HSDPA_Link

Note:

1. Regards to the frequency band operation: the lowest, middle and highest frequency of channel were selected to perform the test, then shown on this report.
2. The maximum power level of GSM or GPRS mode for GMSK link, EDGE mode for 8PSK link, (The maximum power of GPRS and EGPRS of all multi-slot modes are GPRS-1slot and EGPRS-1slot.) RMC 12.2Kbps Mode for WCDMA band 5 & 2, only these modes were used for all tests.



### 1.3. Tested System Details

The types for all equipment, plus descriptions of all cables used in the tested system (including inserted cards) are:

Product	Manufacturer	Model No.	Serial No.	Power Cord
1   Base Station	JRC	NJZ-2000	ET00477	--
2   Horn	SCHWARZBECK	BBHA9120D	01656	--

### 1.4. Configuration of Tested System

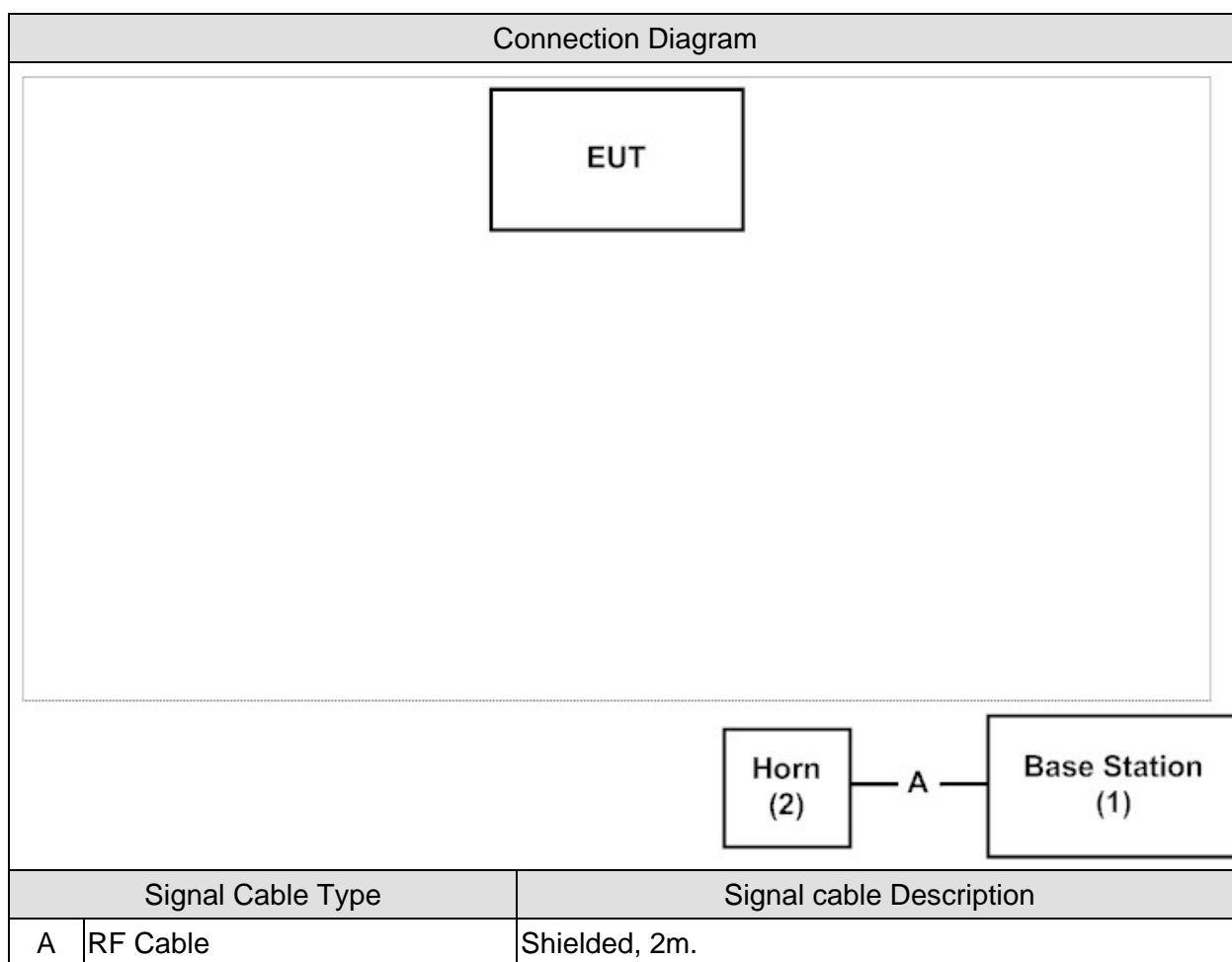

### 1.5. EUT Exercise Software

1	Setup the EUT and simulators as shown on 1.7.
2	Turn on the power of all equipment. Horn link with base station.
3	The EUT link with base station and it will continue receive the signal from WCDMA function.
4	Repeat the above procedure.

## 2. Technical Test

### 2.1. Summary of Test Result

- No deviations from the test standards
- Deviations from the test standards as below description:

#### For GPRS850/EGPRS850/WCDMA Band5

##### (FCC Part 22 Subpart H, Industry Canada RSS-132, Issue 3, Industry Canada RSS-GEN )

Performed Item	FCC Rule	IC Rule	Limit	Result
Maximum Output Power	§2.1033	§5.4	< 7 Watts	Pass
	§2.1046			
	§22.913			
Equivalent Isotropic Radiated Power	§22.913	§5.4	< 7 Watts	Pass
Occupied Bandwidth	§2.1049	RSS-GEN §4.2	N/A	Pass
Conducted Band Edge Emissions	§22.917	§5.5	< -13dBm	Pass
Field Strength of Spurious Radiation	§2.1053	§5.5	< -13dBm	Pass
	§§22.917			
Frequency Stability Under Temperature & Voltage Variations	§2.1055	§5.3	< 2.5 ppm	Pass
	§22.335			

#### For GPRS1900/EGPRS1900/WCDMA Band2

##### (FCC Part 24 Subpart E, Industry Canada RSS-133, Issue 6, Industry Canada RSS-GEN )

Performed Item	FCC Rule	IC Rule	Limit	Result
Maximum Output Power	§2.1033	§6.4	< 2 Watts	Pass
	§2.1046			
	§24.232			
Equivalent Isotropic Radiated Power	§24.232	§6,4	< 2 Watts	Pass
Occupied Bandwidth	§2.1049	RSS-GEN §4.2	N/A	Pass
Conducted Band Edge Emissions	§27.238	§6.5	< -13dBm	Pass
Field Strength of Spurious Radiation	§2.1053	§6.5	< -13dBm	Pass
	§24.238			
Frequency Stability Under Temperature & Voltage Variations	§2.1055	§6.3	< 2.5 ppm	Pass
	§24.235			

## 2.2. Test Environment

Items	Required (IEC 68-1)	Actual
Temperature (°C)	15-35	23
Humidity (%RH)	25-75	52
Barometric pressure (mbar)	860-1060	950-1000

### 3. Maximum Output Power, Effective Isotropic Radiated Power and Effective Radiated Power Measurement

#### 3.1. Test Equipment

Maximum Conducted Output Power / SR10-H

Instrument	Manufacturer	Type No.	Serial No	Cali. Due Date
Multisystem UE Tester	Japan radio	NJZ-2000	ET00477	2017/09/19
Directional coupler	Agilent	778D	20402	2017/10/06
Signal & Spectrum Analyzer	R&S	FSV40	101049	2018/01/05
Power Meter	Anritsu	ML2496A	1602004	2018/01/19

#### 3.2. Test Setup

Conducted Output Power:

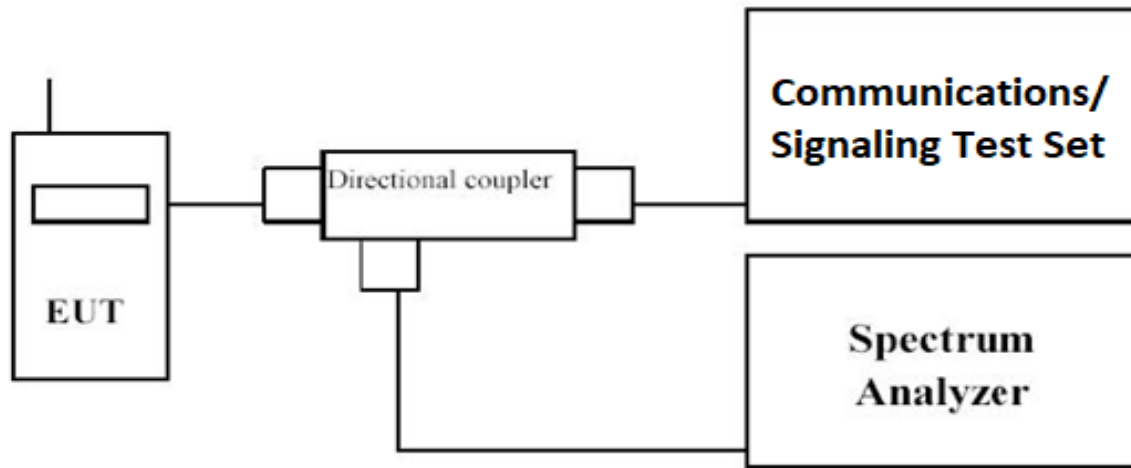

### 3.3. Test Procedure

#### Conducted Power Measurement:

- a) The RF output of the transmitter was connected to base station simulator.
- b) The RF output of EUT was connected to the spectrum analyzer by RF cable and attenuator. The path loss was compensated to the results for each measurement..
- c) Set EUT at maximum average power by base station simulator.
- d) Measure lowest, middle, and highest channels for each bandwidth and different modulation.

**Effective Isotropic Radiated Power= Conducted Power(dBm) + Antenna Gain(dBi)**

**Effective Radiated Power= Conducted Power(dBm) + Antenna Gain(dBi)-2.15dB**

### 3.4. Uncertainty

The measurement uncertainty is defined as  $\pm 1.2\text{dB}$ .

### 3.5. Test Result

Product	3G Cellular Alarm Communicator		
Test Item	Maximum Output Power, EIRP, ERP		
Test Mode	Mode1: GPRS 850_Link		
Date of Test	2017/05/22	Test Site	SR10-H

Frequency (MHz)	Modulation	Conducted Power (Average) dBm	Antenna Gain (dBi)	ERP (dBm)	Limit (dBm)	Margin (dB)
824.2	GPRS	31.93	1.53	31.31	38.45	-7.14
836.6		32.41		31.79		-6.66
848.8		33.09		32.47		-5.98

Product	3G Cellular Alarm Communicator		
Test Item	Maximum Output Power, EIRP, ERP		
Test Mode	Mode 2: GPRS 1900_Link		
Date of Test	2017/05/22	Test Site	SR10-H

Frequency (MHz)	Modulation	Conducted Power (Average) dBm	Antenna Gain (dBi)	EIRP (dBm)	Limit (dBm)	Margin (dB)
1850.2	GPRS	29.53	2.07	31.60	33.00	-1.40
1880		29.45		31.52		-1.48
1909.8		29.38		31.45		-1.55

Product	3G Cellular Alarm Communicator		
Test Item	Maximum Output Power, EIRP, ERP		
Test Mode	Mode 3: EGPRS 850_Link		
Date of Test	2017/05/22	Test Site	SR10-H

Frequency (MHz)	Modulation	Conducted Power (Average) dBm	Antenna Gain (dBi)	ERP (dBm)	Limit (dBm)	Margin (dB)
824.2	EGPRS	26.37	1.53	25.75	38.45	-12.70
836.6		26.82		26.20		-12.25
848.8		26.75		26.13		-12.32



Product	3G Cellular Alarm Communicator		
Test Item	Maximum Output Power, EIRP, ERP		
Test Mode	Mode 4: EGPRS 1900_Link		
Date of Test	2017/05/22	Test Site	SR10-H

Frequency (MHz)	Modulation	Conducted Power (Average) dBm	Antenna Gain (dBi)	EIRP (dBm)	Limit (dBm)	Margin (dB)
1850.2	EGPRS	25.75	2.07	27.82	33.00	-5.18
1880		25.74		27.81		-5.19
1909.8		25.72		27.79		-5.21

<b>Product</b>	3G Cellular Alarm Communicator		
<b>Test Item</b>	Maximum Output Power, EIRP, ERP		
<b>Test Mode</b>	Mode 5: WCDMA Band 5_Link		
<b>Date of Test</b>	2017/05/22	<b>Test Site</b>	SR10-H

<b>Frequency (MHz)</b>	<b>Modulation</b>	<b>Conducted Power (Average) dBm</b>	<b>Antenna Gain (dBi)</b>	<b>ERP (dBm)</b>	<b>Limit (dBm)</b>	<b>Margin (dB)</b>
826.4	WCDMA	22.89	1.53	22.27	38.45	-16.18
836.4		23.49		22.87		-15.58
846.6		23.95		23.33		-15.12

Product	3G Cellular Alarm Communicator		
Test Item	Maximum Output Power, EIRP, ERP		
Test Mode	Mode 6: WCDMA Band 5_HSUPA_Link		
Date of Test	2017/05/22	Test Site	SR10-H

Frequency (MHz)	Modulation	Conducted Power (Average) dBm	Antenna Gain (dBi)	ERP (dBm)	Limit (dBm)	Margin (dB)
826.4	HSUPA	23.18	1.53	22.56	38.45	-15.89
836.4		23.60		22.98		-15.47
846.6		23.56		22.94		-15.51

Product	3G Cellular Alarm Communicator		
Test Item	Maximum Output Power, EIRP, ERP		
Test Mode	Mode 7: WCDMA Band 5_HSDPA_Link		
Date of Test	2017/05/22	Test Site	SR10-H

Frequency (MHz)	Modulation	Conducted Power (Average) dBm	Antenna Gain (dBi)	ERP (dBm)	Limit (dBm)	Margin (dB)
826.4	HSDPA	22.64	1.53	22.02	38.45	-16.43
836.4		23.13		22.51		-15.94
846.6		23.38		22.76		-15.69

Product	3G Cellular Alarm Communicator		
Test Item	Maximum Output Power, EIRP, ERP		
Test Mode	Mode 8: WCDMA Band 2_Link		
Date of Test	2017/05/22	Test Site	SR10-H

Frequency (MHz)	Modulation	Conducted Power (Average) dBm	Antenna Gain (dBi)	EIRP (dBm)	Limit (dBm)	Margin (dB)
1852.4	WCDMA	23.24	2.07	25.31	33.00	-7.69
1880		21.83		23.90		-9.11
1907.6		20.96		23.03		-9.97

Product	3G Cellular Alarm Communicator		
Test Item	Maximum Output Power, EIRP, ERP		
Test Mode	Mode 9: WCDMA Band 2_HSUPA_Link		
Date of Test	2017/05/22	Test Site	SR10-H

Frequency (MHz)	Modulation	Conducted Power (Average) dBm	Antenna Gain (dBi)	EIRP (dBm)	Limit (dBm)	Margin (dB)
1852.4	HSUPA	23.68	2.07	25.75	33.00	-7.25
1880		22.49		24.56		-8.44
1907.6		21.37		23.44		-9.56

Product	3G Cellular Alarm Communicator		
Test Item	Maximum Output Power, EIRP, ERP		
Test Mode	Mode 10: WCDMA Band 2_HSDPA_Link		
Date of Test	2017/05/22	Test Site	SR10-H

Frequency (MHz)	Modulation	Conducted Power (Average) dBm	Antenna Gain (dBi)	EIRP (dBm)	Limit (dBm)	Margin (dB)
1852.4	HSDPA	23.57	2.07	25.64	33.00	-7.36
1880		22.37		24.44		-8.56
1907.6		21.41		23.48		-9.52

## 4. Occupied Bandwidth

### 4.1. Test Equipment

Occupied Bandwidth / SR10-H

Instrument	Manufacturer	Type No.	Serial No	Cali. Due Date
Signal & Spectrum Analyzer	R&S	FSVA40	101455	2017/11/27
Multisystem UE Tester	Japan radio	NJZ-2000	ET00477	2017/09/19
Directional coupler	Agilent	778D	20402	2017/10/06

### 4.2. Test Setup

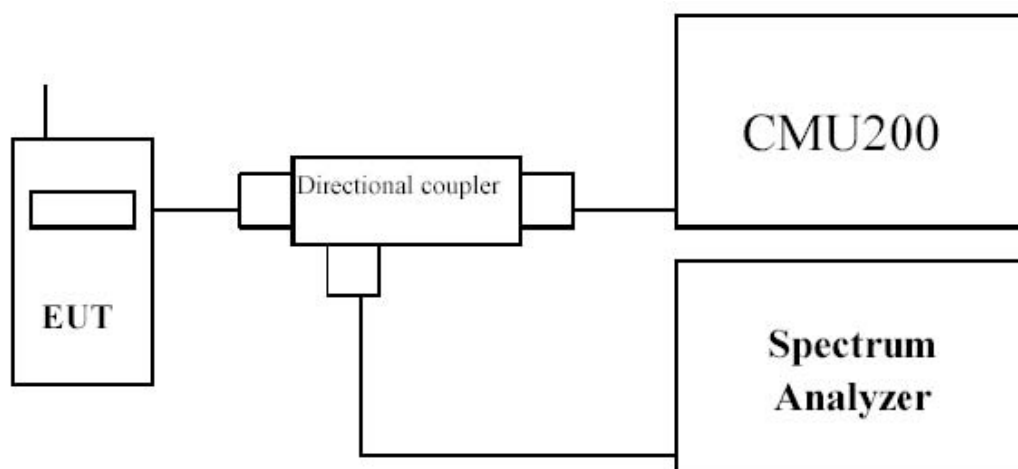

### 4.3. Test Procedure

1. The EUT was connected to Spectrum Analyzer and Base Station via power divider.
2. The RF output of EUT was connected to the spectrum analyzer by RF cable and attenuator. The path loss was compensated to the results for each measurement.
3. The 99% occupied bandwidth and 26 dB bandwidth of the low & middle & high channel for the highest RF powers were measured.

### 4.4. Uncertainty

The measurement uncertainty is defined as  $\pm 10$  Hz



**4.5. Test Result**

Product	3G Cellular Alarm Communicator		
Test Item	Occupied Bandwidth		
Test Mode	Mode 1: GPRS 850_Link		
Date of Test	2017/05/25	Test Site	SR10-H

Frequency (MHz)	-26dB BW Measure Level (MHz)	99% BW Measure Level (MHz)	Limit (MHz)
824.2	0.311	0.243	N/A
836.6	0.291	0.241	N/A
848.8	0.316	0.243	N/A

Figure Channel 128 (824.20MHz) (-26dB BW)

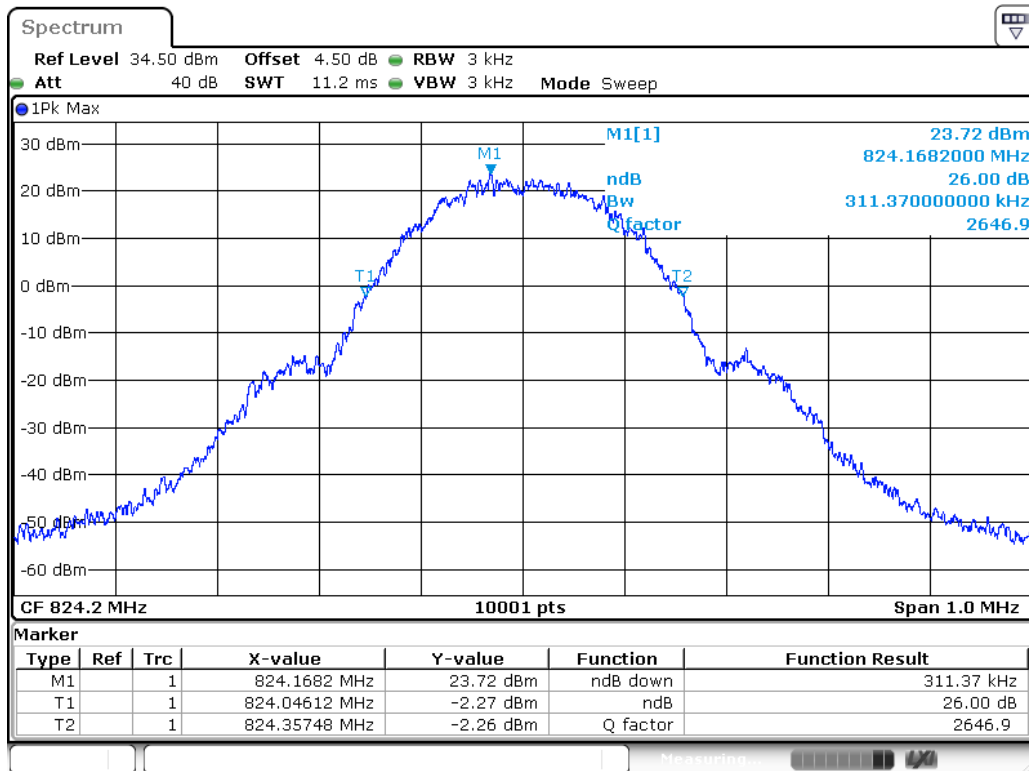

Date: 25 MAY 2017 18:12:28

Figure Channel 128 (824.20MHz) (99% BW)

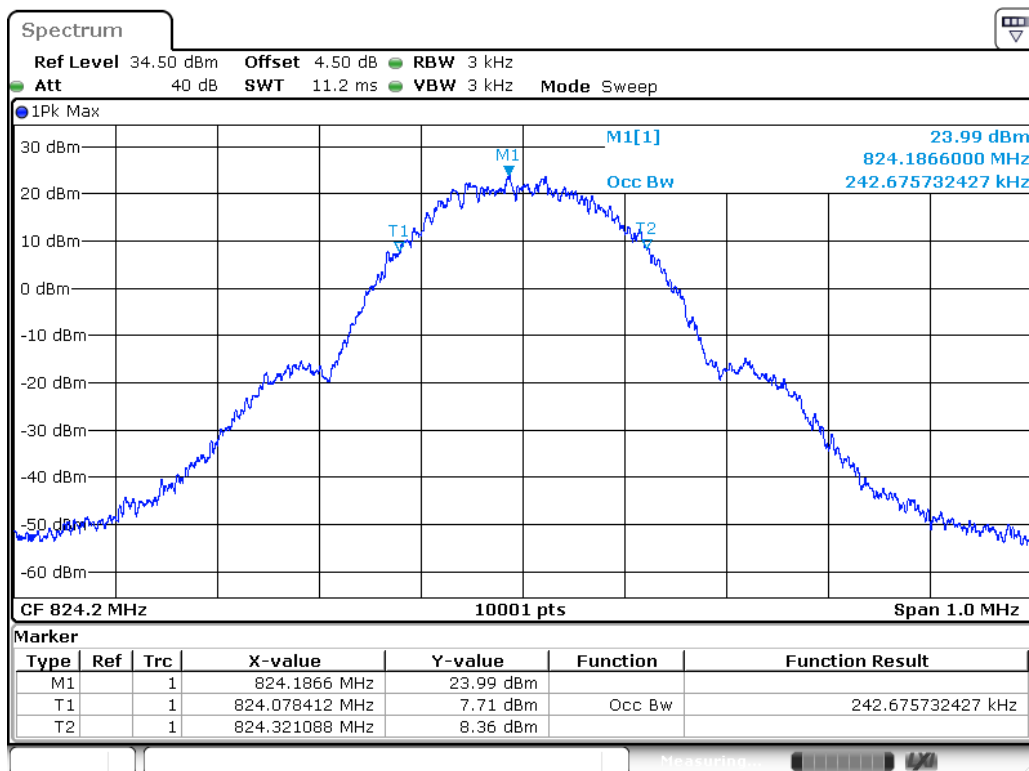

Date: 25 MAY 2017 18:19:54

### Figure Channel 190 (836.60MHz) (-26dB BW)

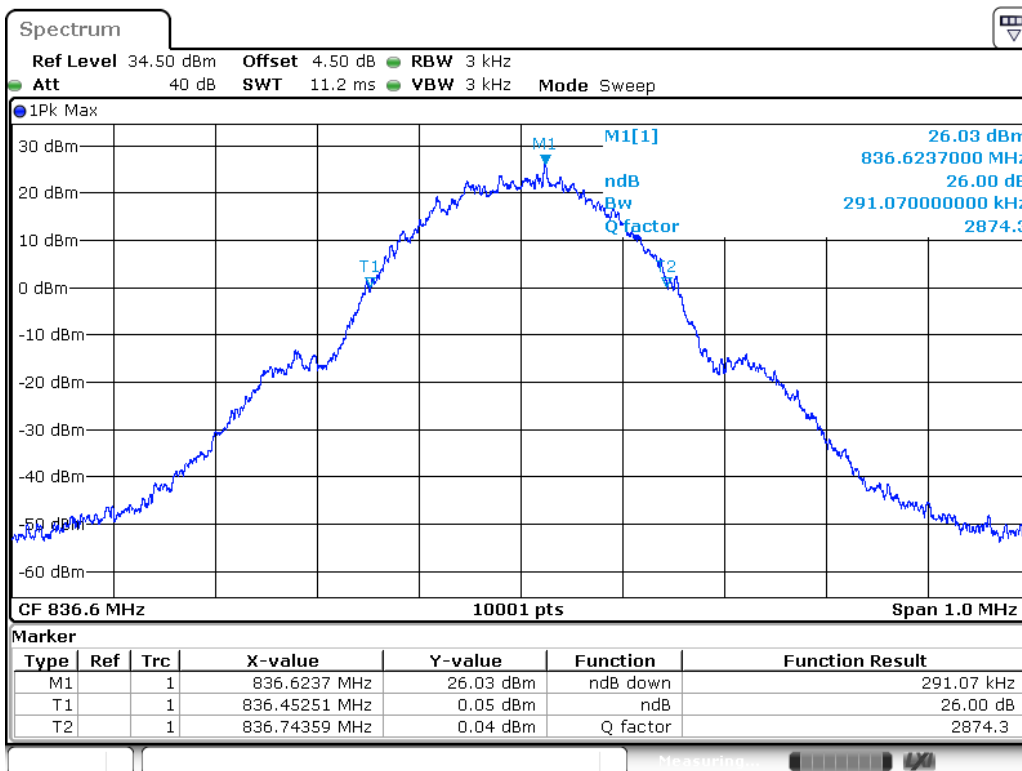

Date: 25 MAY 2017 18:13:58

### Figure Channel 190 (836.60MHz) (99% BW)

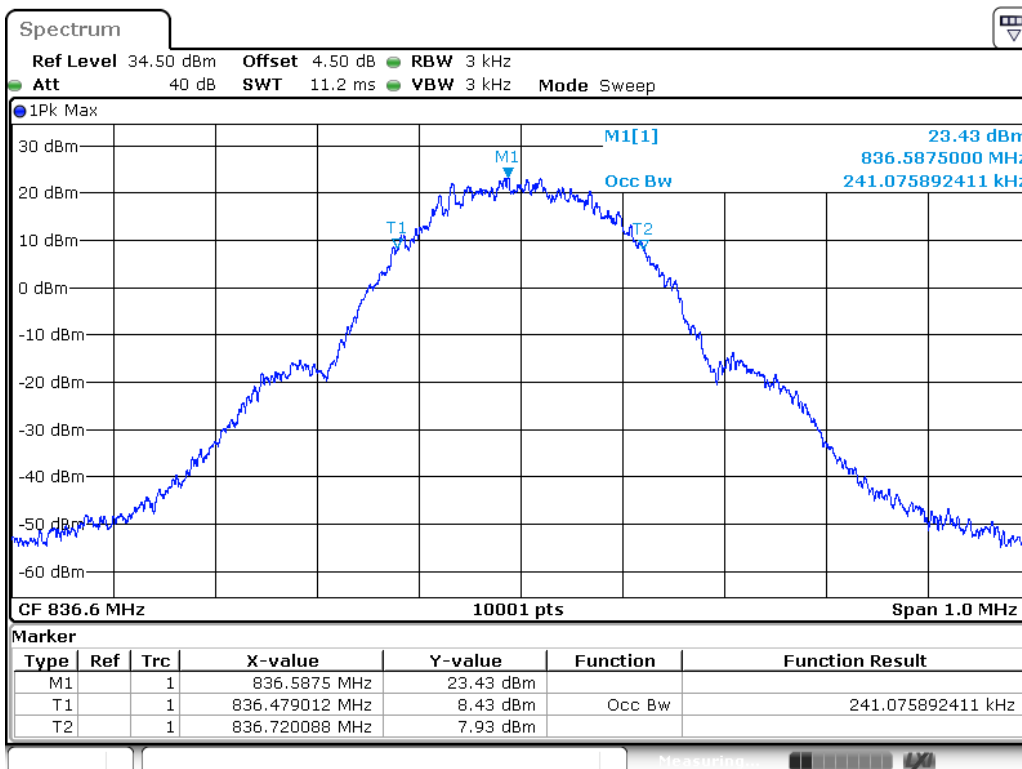

Date: 25 MAY 2017 18:18:44

### Figure Channel 251 (848.80MHz) (-26dB BW)

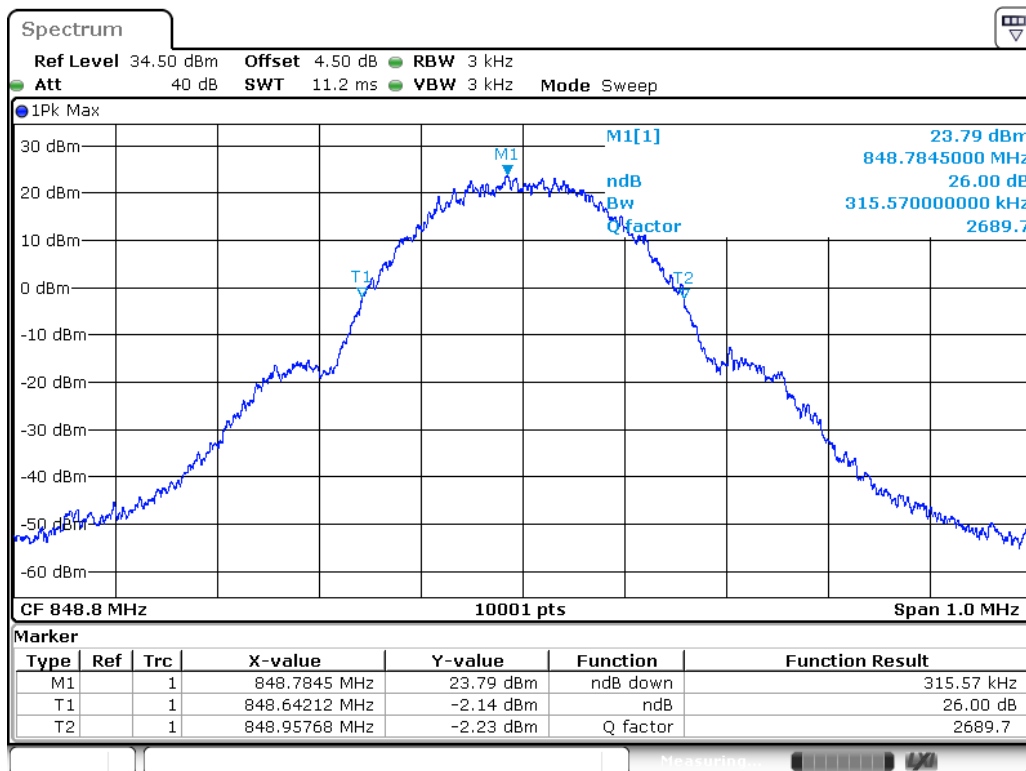

Date: 25 MAY 2017 18:15:21

### Figure Channel 251 (848.80MHz) (99% BW)

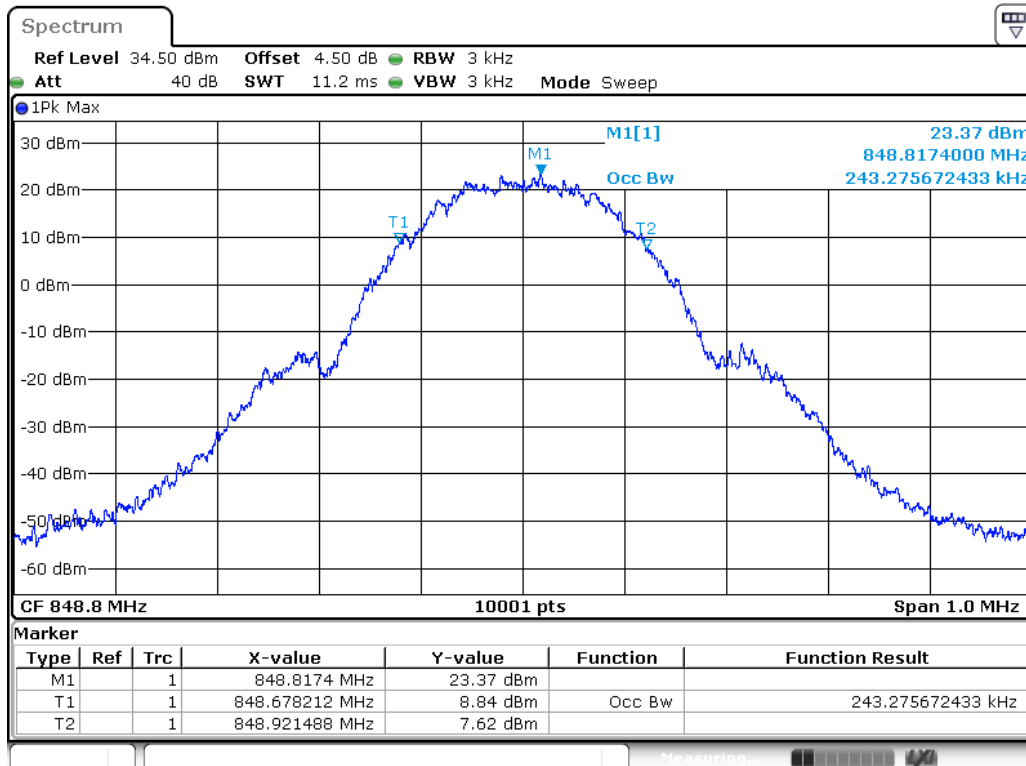

Date: 25 MAY 2017 18:16:37

Product	3G Cellular Alarm Communicator		
Test Item	Occupied Bandwidth		
Test Mode	Mode 2: GPRS 1900_Link		
Date of Test	2017/05/25	Test Site	SR10-H

Frequency (MHz)	-26dB BW Measure Level (MHz)	99% BW Measure Level (MHz)	Limit (MHz)
1850.2	0.317	0.245	N/A
1880.0	0.312	0.245	N/A
1909.8	0.315	0.244	N/A

**Figure Channel 512 (1850.20MHz) (-26dB BW)**

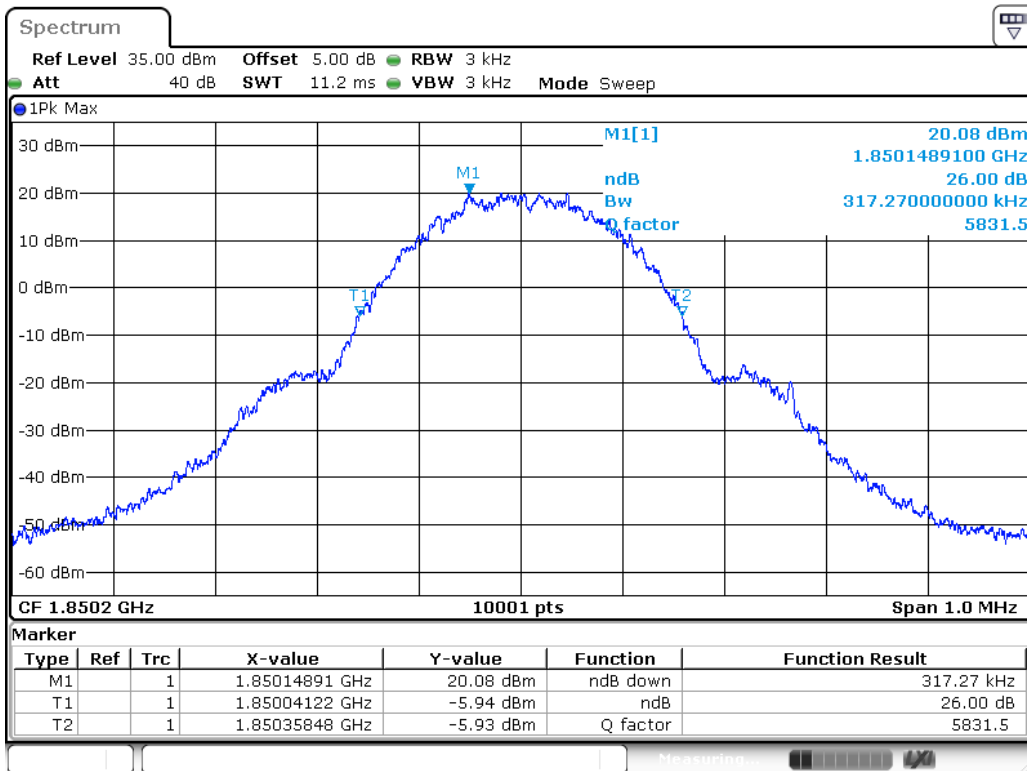

Date: 25 MAY 2017 17:23:03

**Figure Channel 512 (1850.20MHz) (99% BW)**

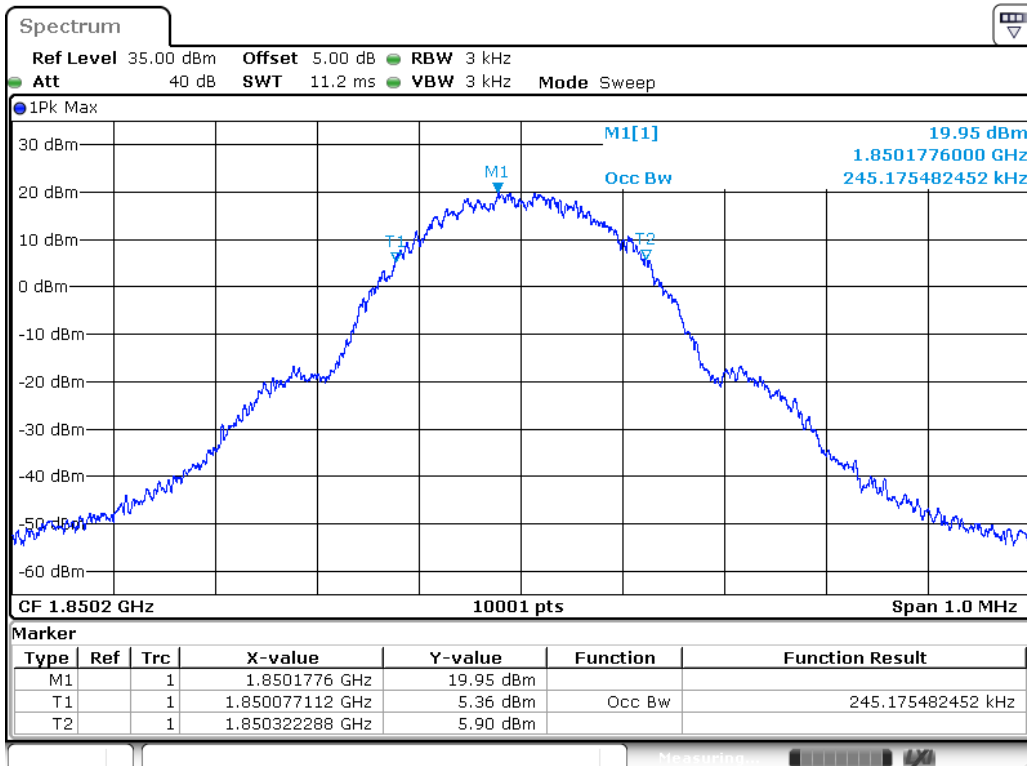

Date: 25 MAY 2017 17:12:39

### Figure Channel 661 (1880.00MHz) (-26dB BW)

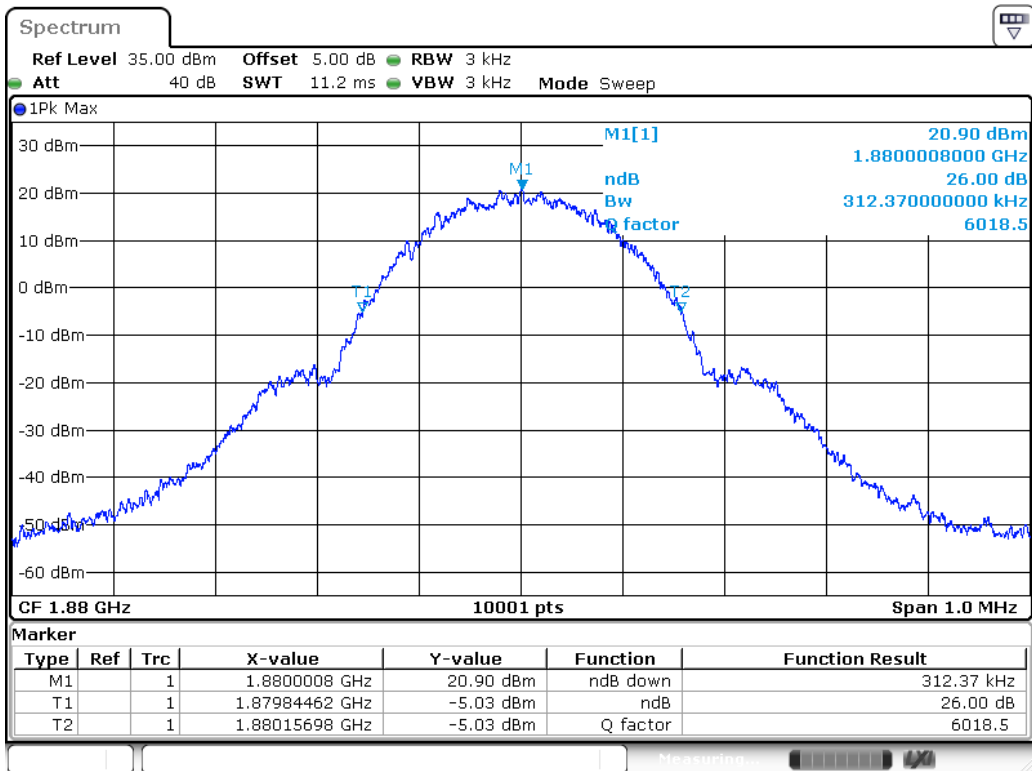

Date: 25 MAY 2017 17:25:08

### Figure Channel 661 (1880.00MHz) (99% BW)

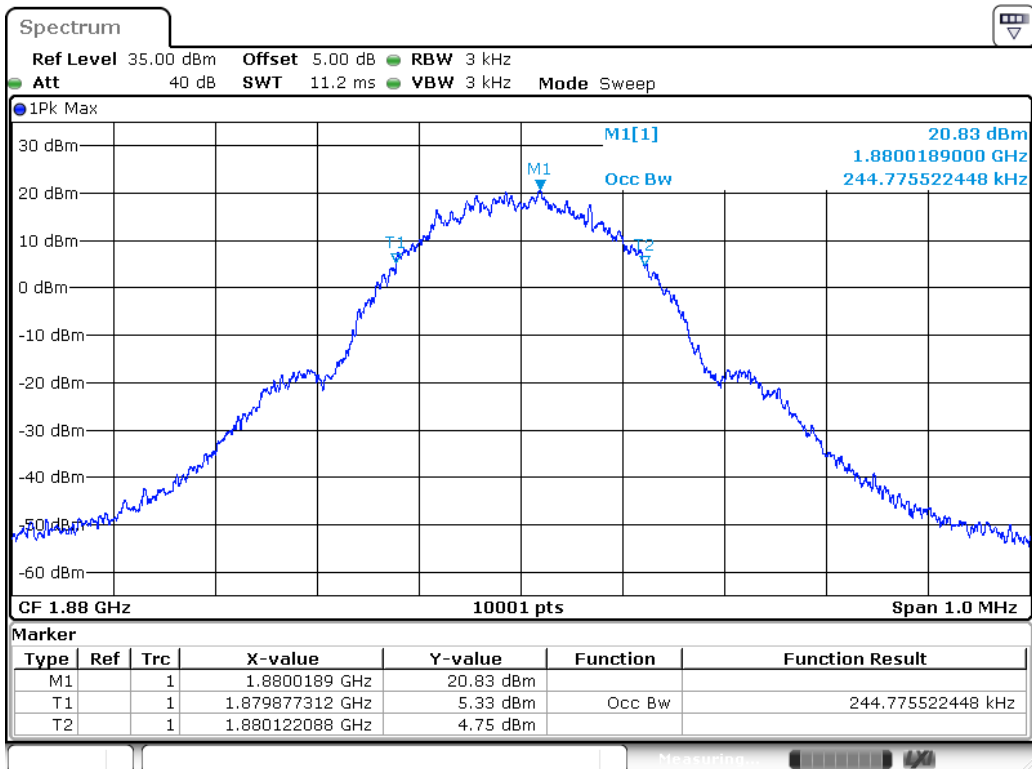

Date: 25 MAY 2017 17:14:10

### Figure Channel 810 (1909.80MHz) (-26dB BW)

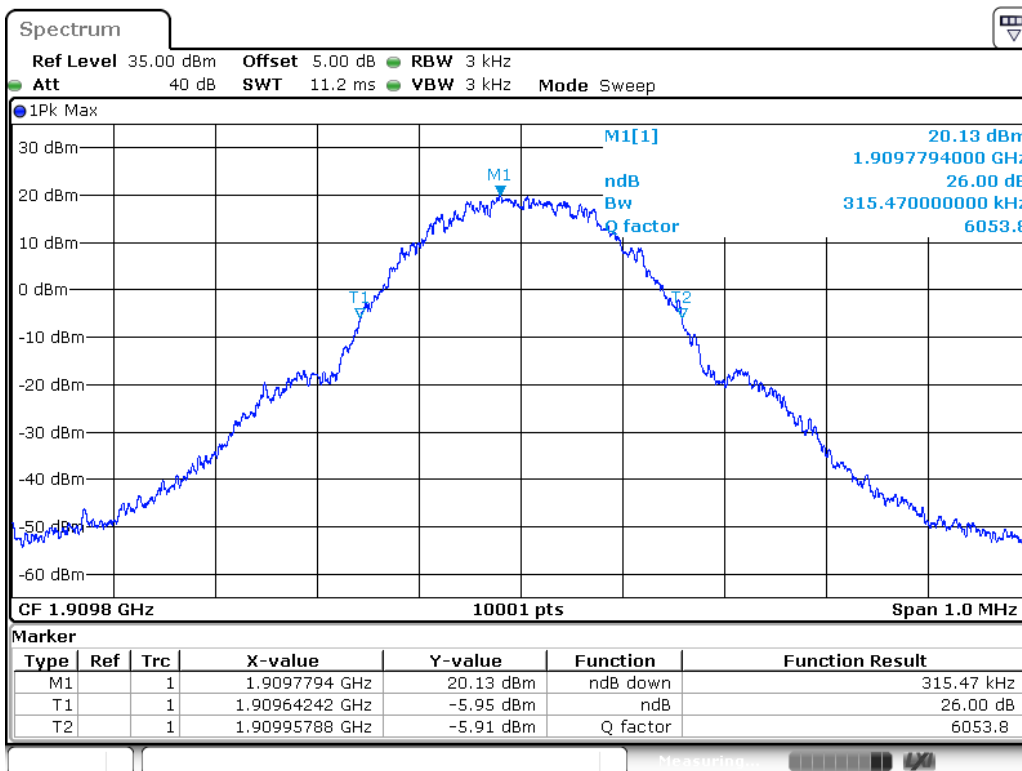

Date: 25 MAY 2017 17:26:52

### Figure Channel 810 (1909.80MHz) (99% BW)

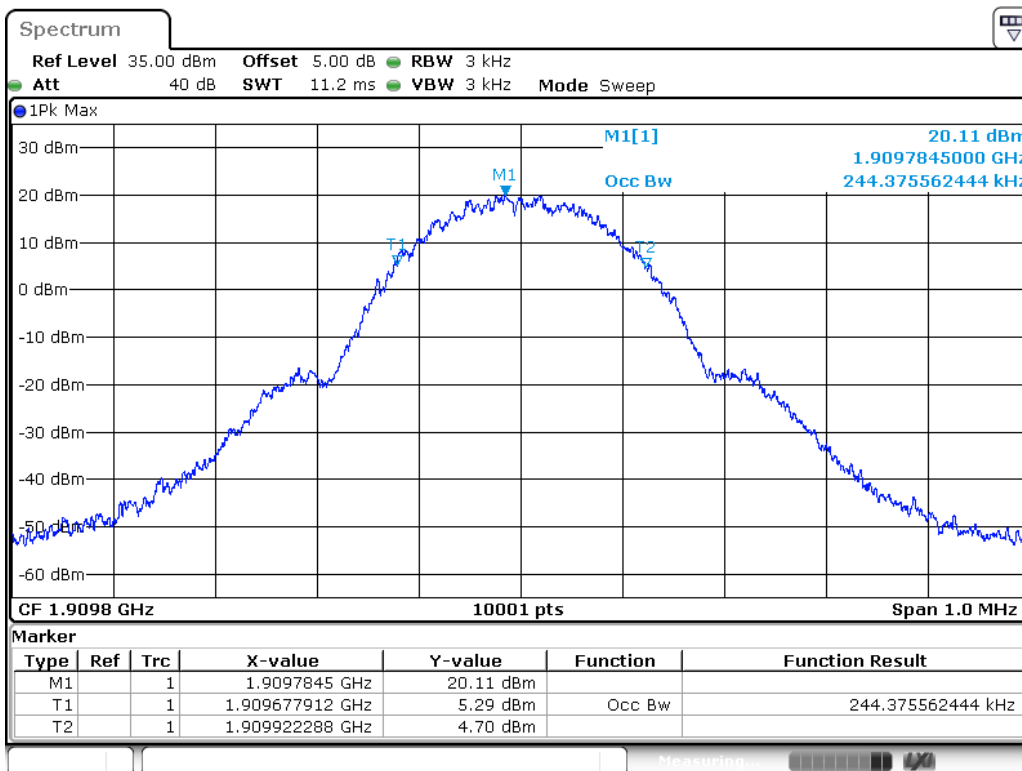

Date: 25 MAY 2017 17:15:59



Product	3G Cellular Alarm Communicator		
Test Item	Occupied Bandwidth		
Test Mode	Mode 3: EGPRS 850_Link		
Date of Test	2017/05/25	Test Site	SR10-H

Frequency (MHz)	-26dB BW Measure Level (MHz)	99% BW Measure Level (MHz)	Limit (MHz)
824.2	0.309	0.244	N/A
836.6	0.292	0.247	N/A
848.8	0.312	0.248	N/A

### Figure Channel 128 (824.20MHz) (-26dB BW)

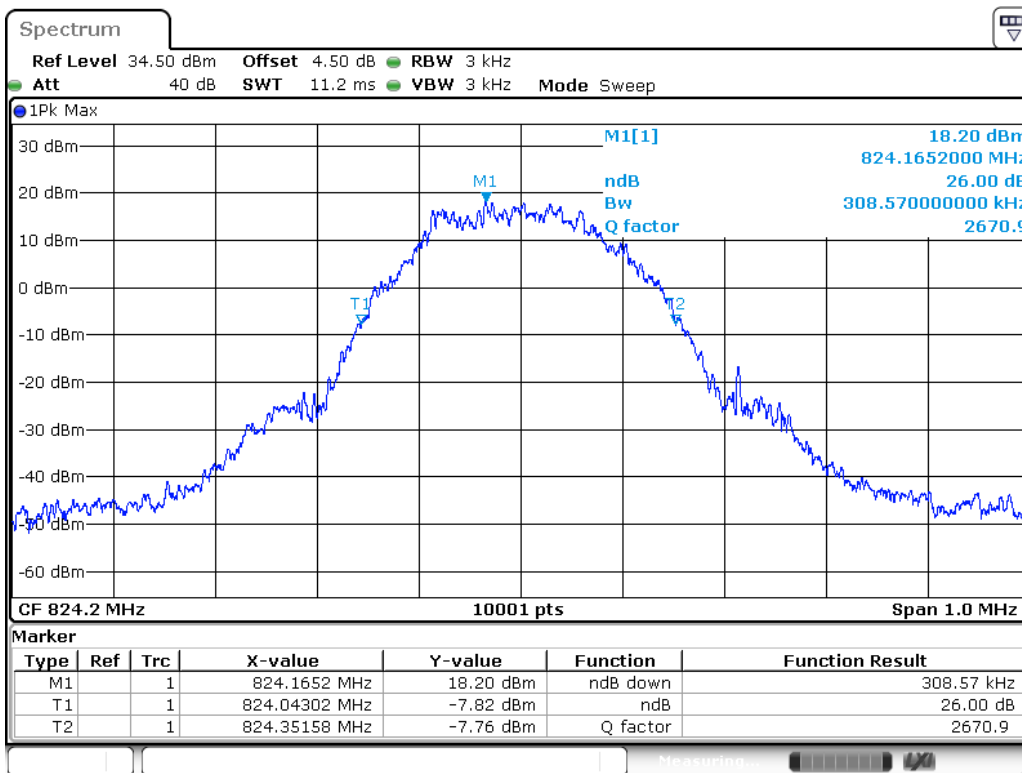

Date: 25 MAY 2017 17:58:48

### Figure Channel 128 (824.20MHz) (99% BW)

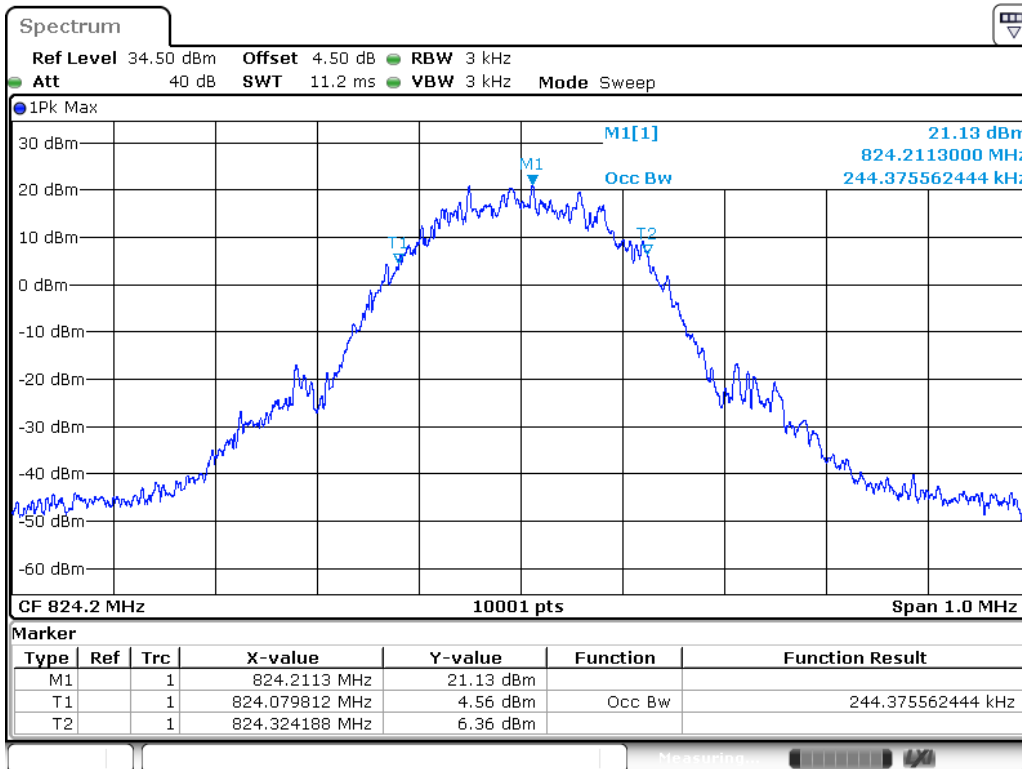

Date: 25 MAY 2017 17:47:44

### Figure Channel 190 (836.60MHz) (-26dB BW)

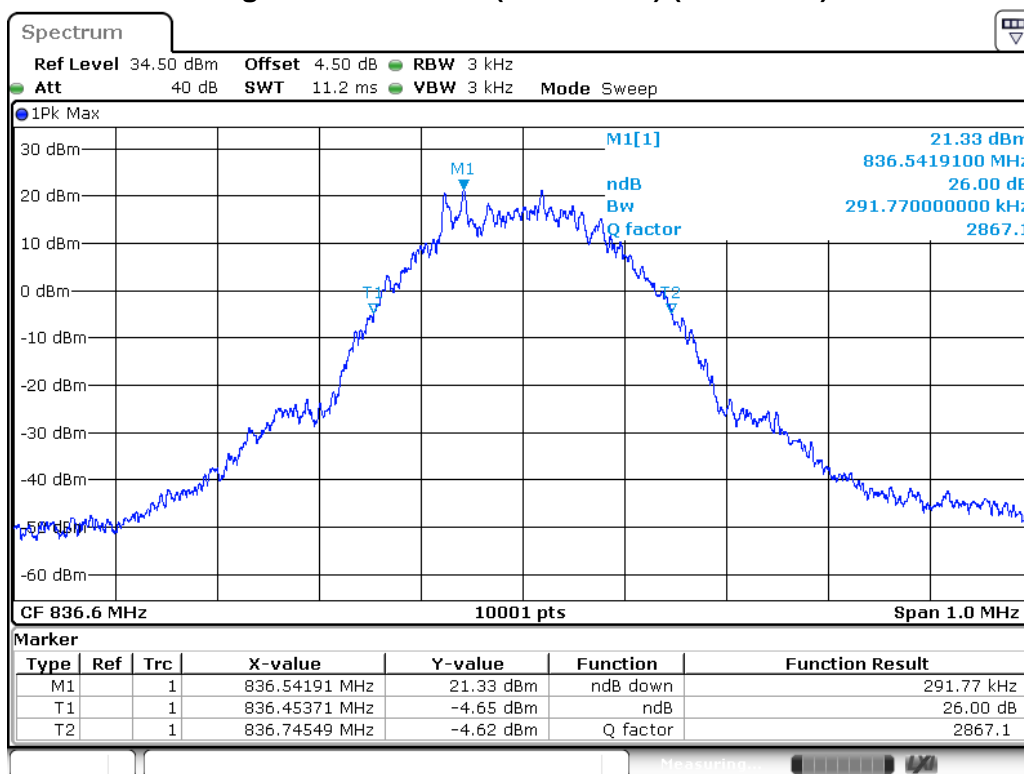

Date: 25 MAY 2017 17:57:50

### Figure Channel 190 (836.60MHz) (99% BW)

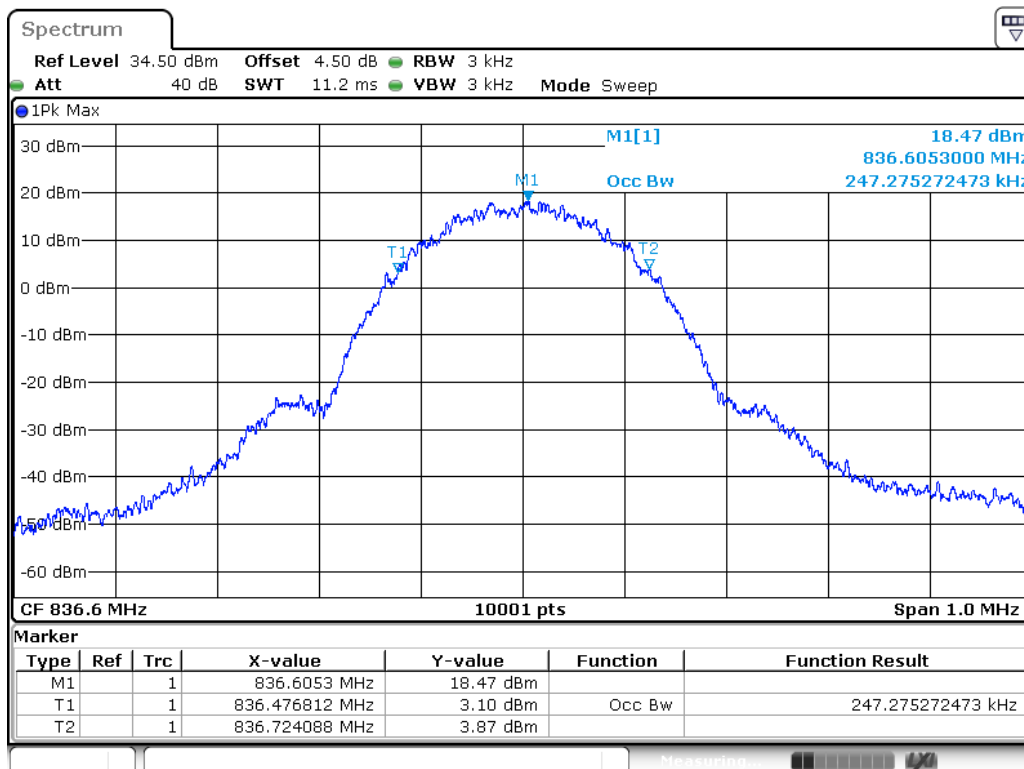

Date: 25 MAY 2017 17:49:37

### Figure Channel 251 (848.80MHz) (-26dB BW)

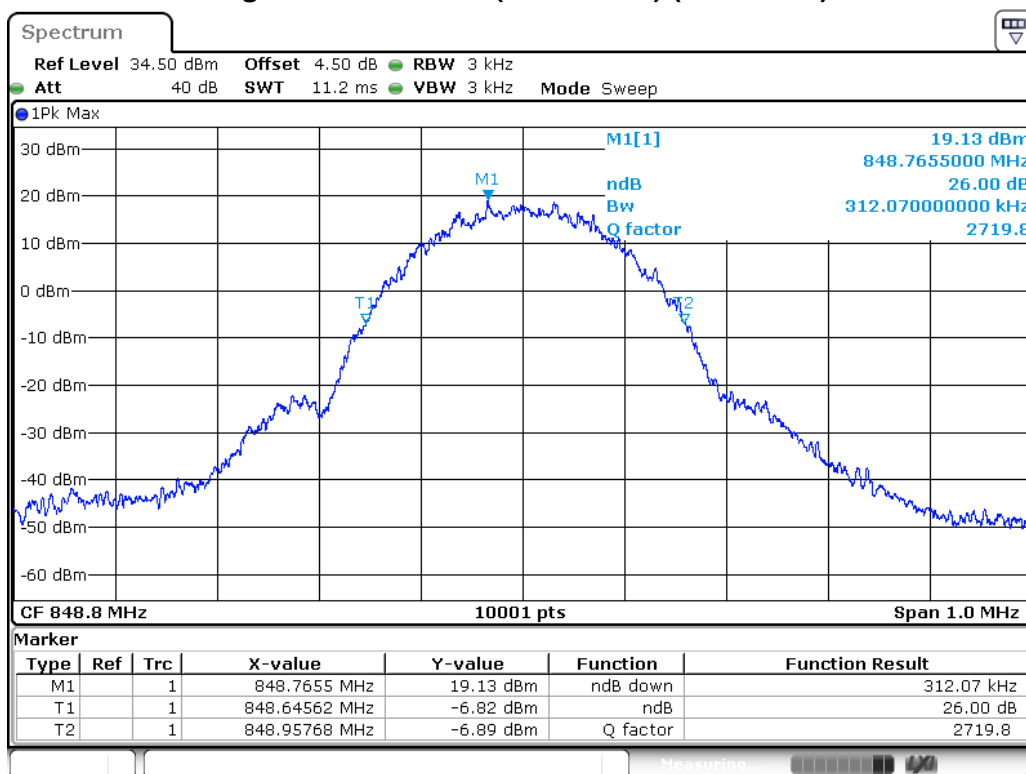

Date: 25 MAY 2017 17:54:31

### Figure Channel 251 (848.80MHz) (99% BW)

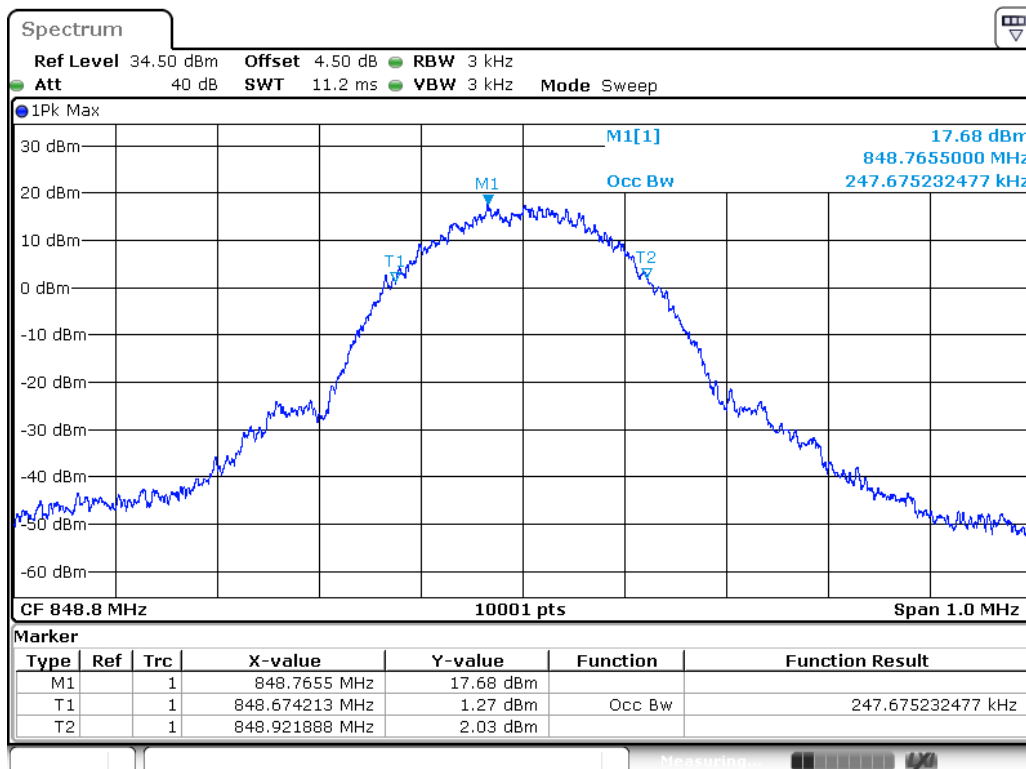

Date: 25 MAY 2017 17:50:31

Product	3G Cellular Alarm Communicator		
Test Item	Occupied Bandwidth		
Test Mode	Mode 4: EGPRS 1900_Link		
Date of Test	2017/05/25	Test Site	SR10-H

Frequency (MHz)	-26dB BW Measure Level (MHz)	99% BW Measure Level (MHz)	Limit (MHz)
1850.2	0.310	0.244	N/A
1880.0	0.302	0.246	N/A
1909.8	0.311	0.249	N/A

Figure Channel 512 (1850.20MHz) (-26dB BW)

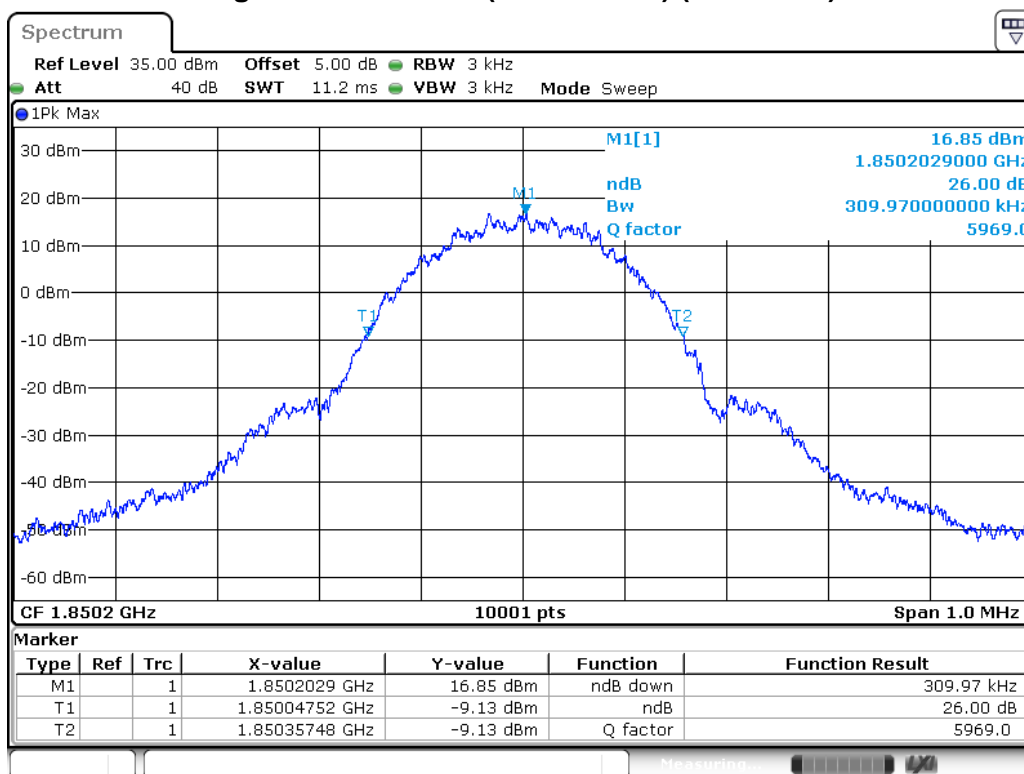

Date: 25 MAY 2017 17:34:34

Figure Channel 512 (1850.20MHz) (99% BW)

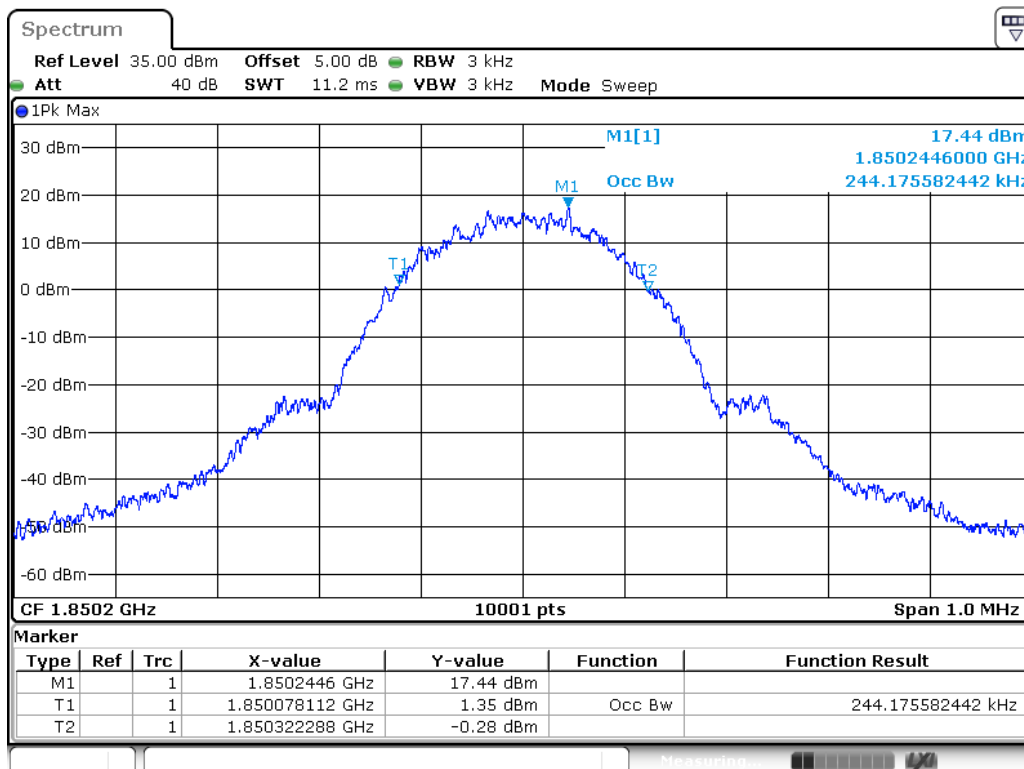

Date: 25 MAY 2017 17:43:59

### Figure Channel 661 (1880.00MHz) (-26dB BW)

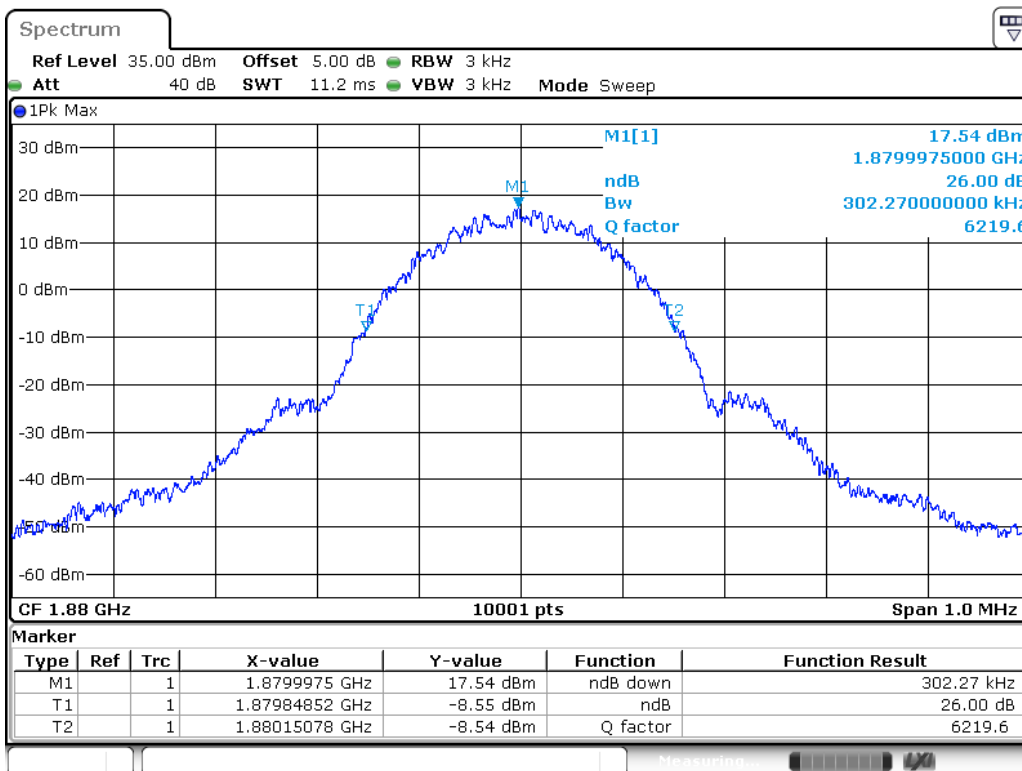

Date: 25 MAY 2017 17:33:12

### Figure Channel 661 (1880.00MHz) (99% BW)

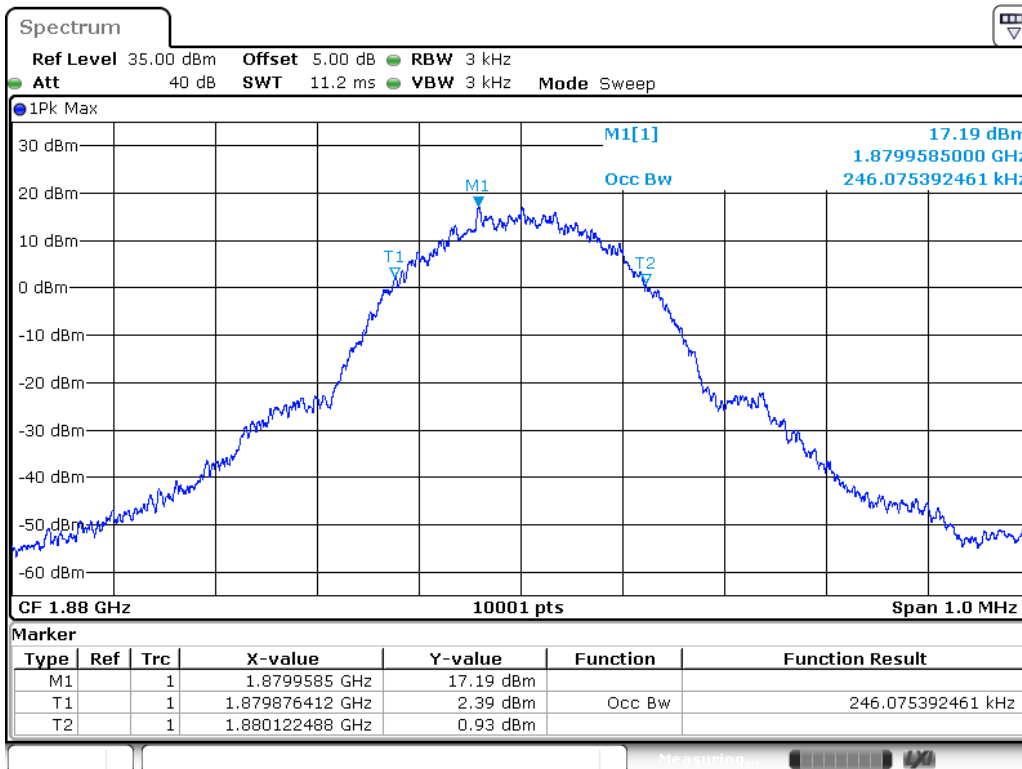

Date: 25 MAY 2017 17:42:42

### Figure Channel 810 (1909.80MHz) (-26dB BW)

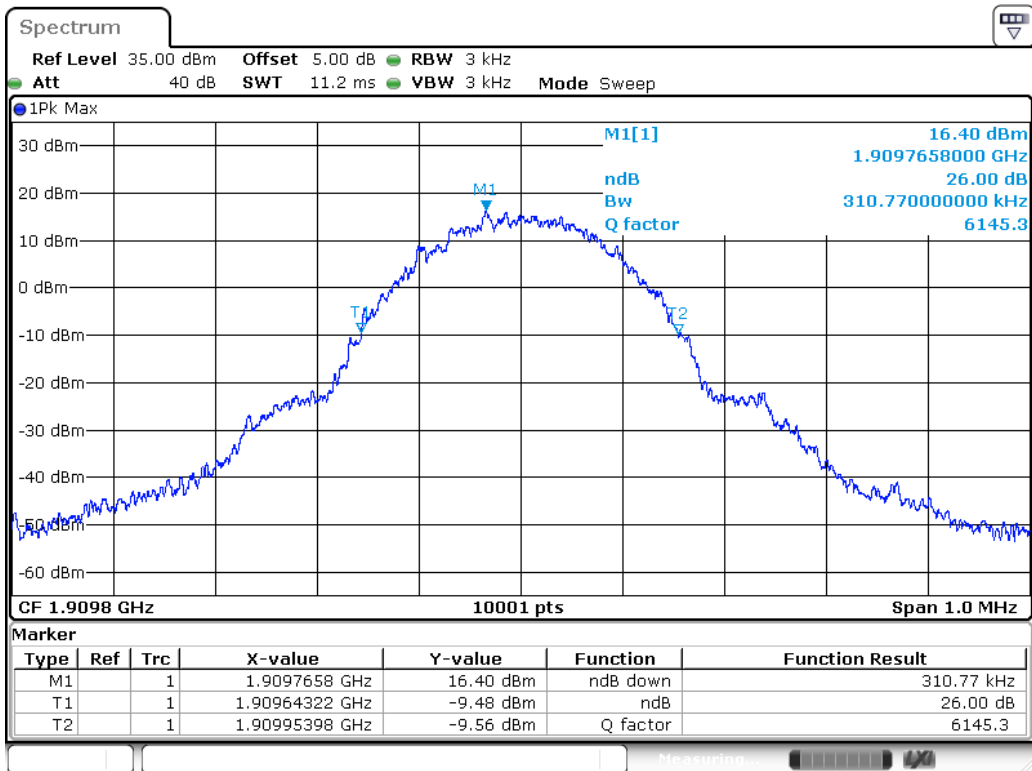

Date: 25 MAY 2017 17:31:54

### Figure Channel 810 (1909.80MHz) (99% BW)

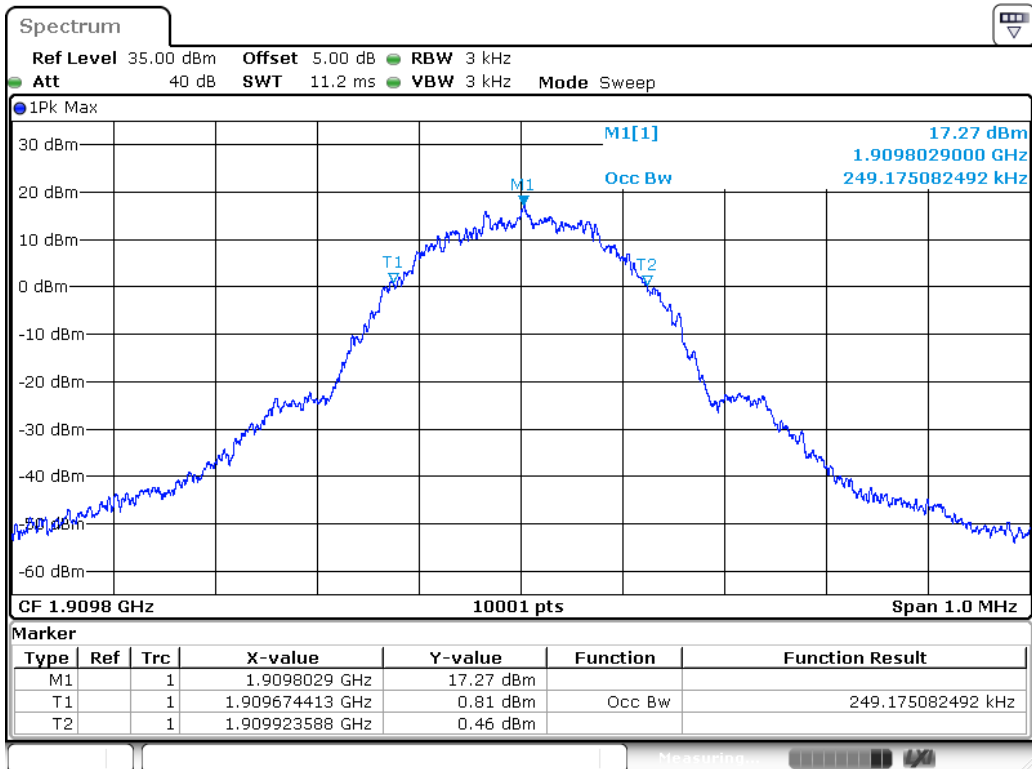

Date: 25 MAY 2017 17:41:35



Product	3G Cellular Alarm Communicator		
Test Item	Occupied Bandwidth		
Test Mode	Mode 5: WCDMA Band 5_Link		
Date of Test	2017/05/25	Test Site	SR10-H

Frequency (MHz)	-26dB BW Measure Level (MHz)	99% BW Measure Level (MHz)	Limit (MHz)
824.2	4.549	4.053	N/A
836.6	4.529	4.038	N/A
848.8	4.513	4.053	N/A

Figure Channel 4132 (826.40MHz) (-26dB BW)

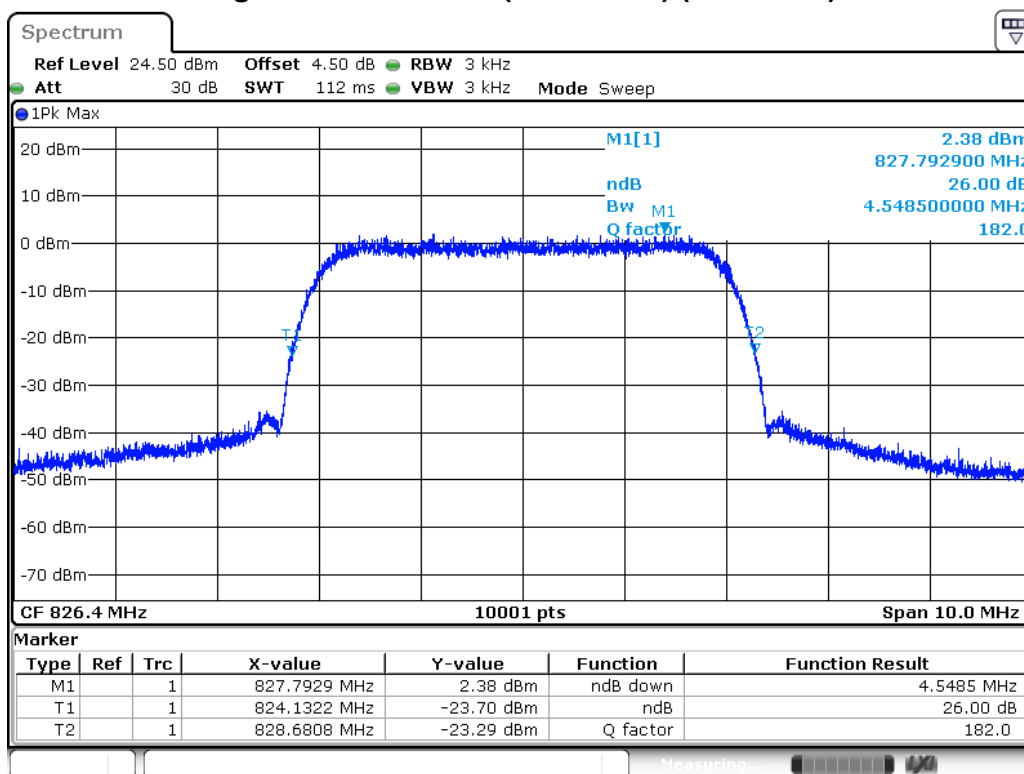

Date: 25 MAY 2017 14:21:40

Figure Channel 4132 (826.40MHz) (99% BW)

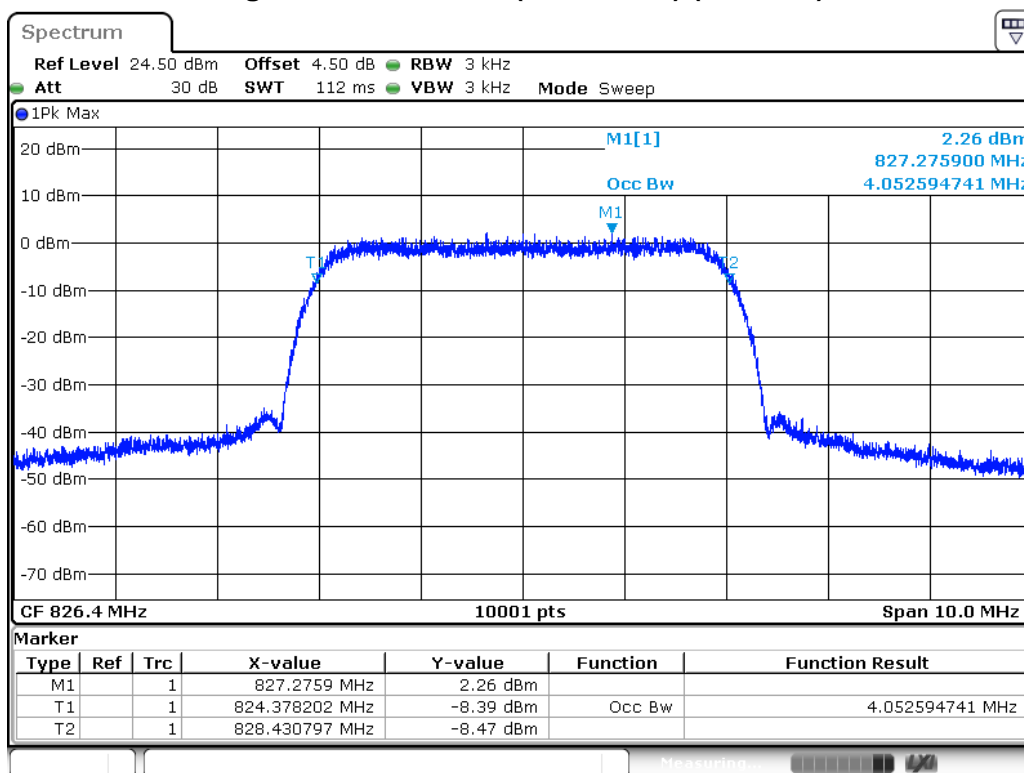

Date: 25 MAY 2017 13:42:38

### Figure Channel 4182 (836.60MHz) (-26dB BW)

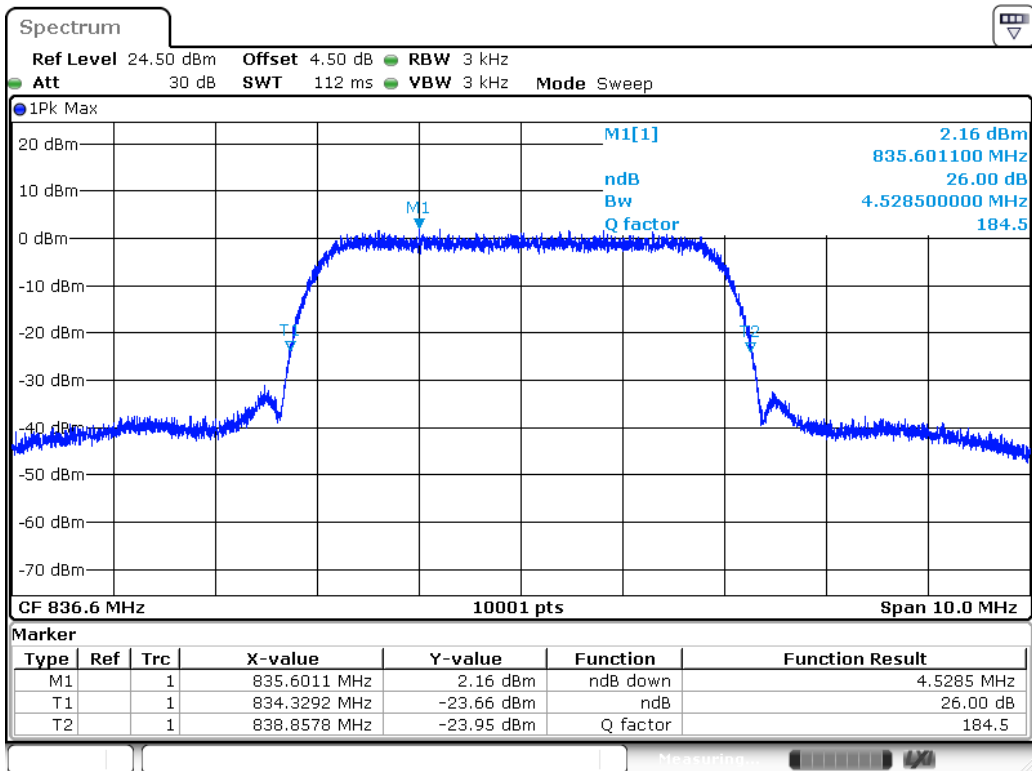

Date: 25 MAY 2017 14:20:30

### Figure Channel 4182 (836.60MHz) (99% BW)

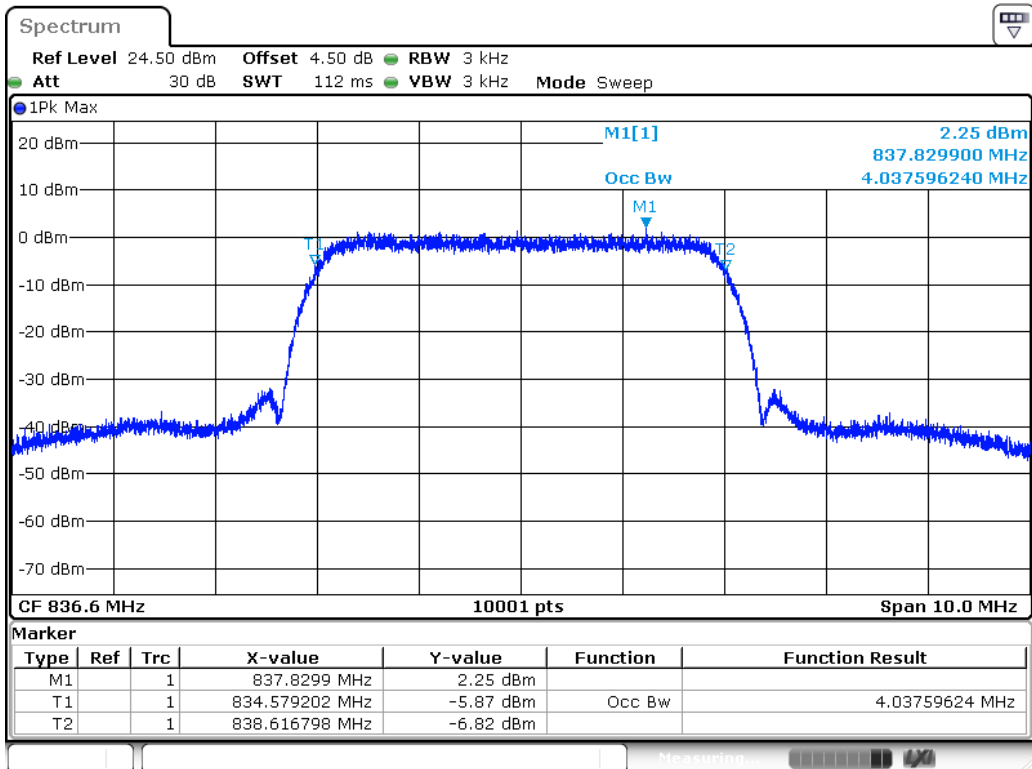

Date: 25 MAY 2017 13:44:16

Figure Channel 4233(846.60MHz) (-26dB BW)

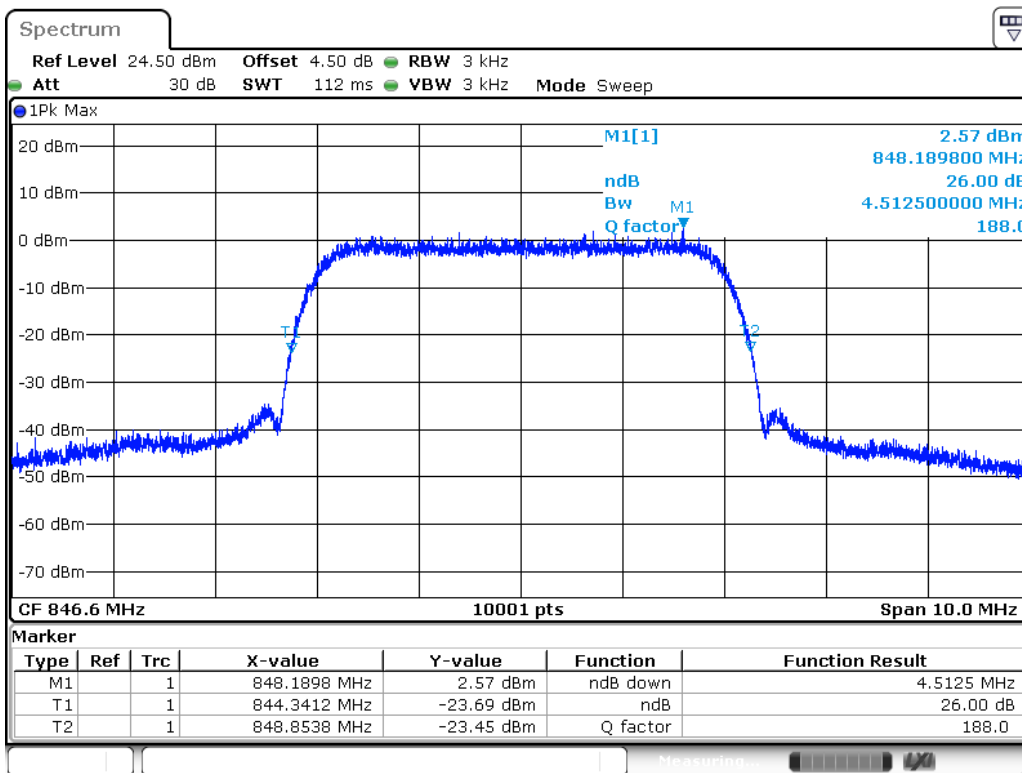

Date: 25 MAY 2017 14:18:42

Figure Channel 4233(846.60MHz) (99% BW)

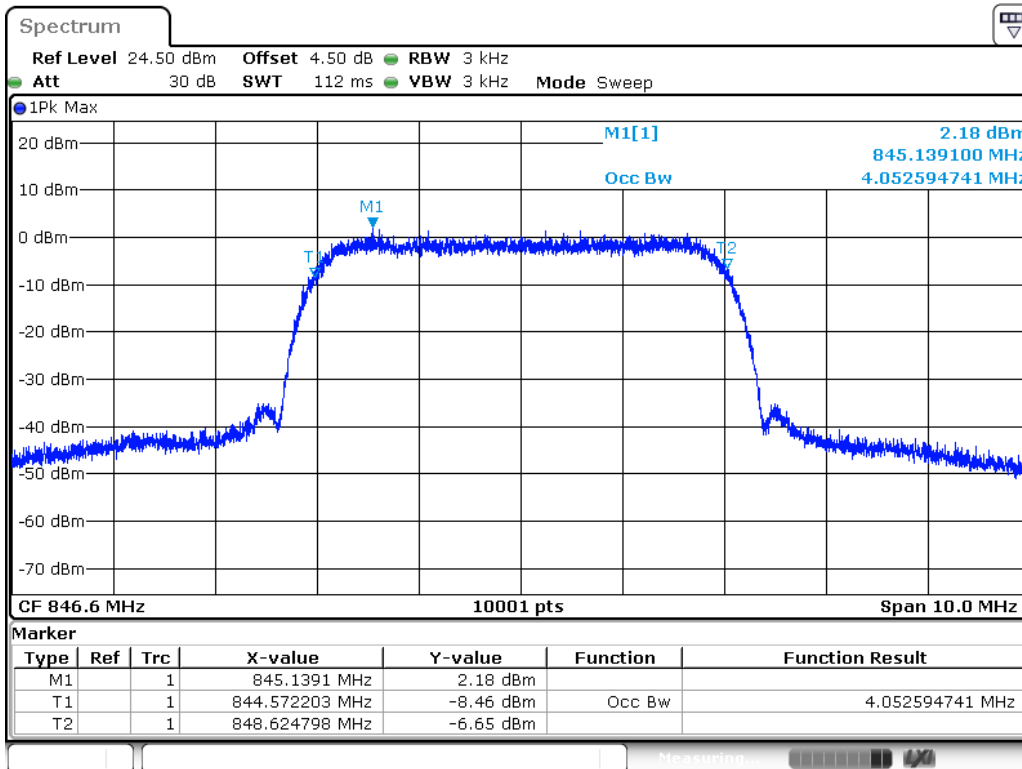

Date: 25 MAY 2017 13:45:14

Product	3G Cellular Alarm Communicator		
Test Item	Occupied Bandwidth		
Test Mode	Mode 6: WCDMA Band 5_HSUPA_Link		
Date of Test	2017/05/25	Test Site	SR10-H

Frequency (MHz)	-26dB BW Measure Level (MHz)	99% BW Measure Level (MHz)	Limit (MHz)
824.2	4.528	4.061	N/A
836.6	4.486	4.047	N/A
848.8	4.495	4.055	N/A

Figure Channel 4132 (826.40MHz) (-26dB BW)

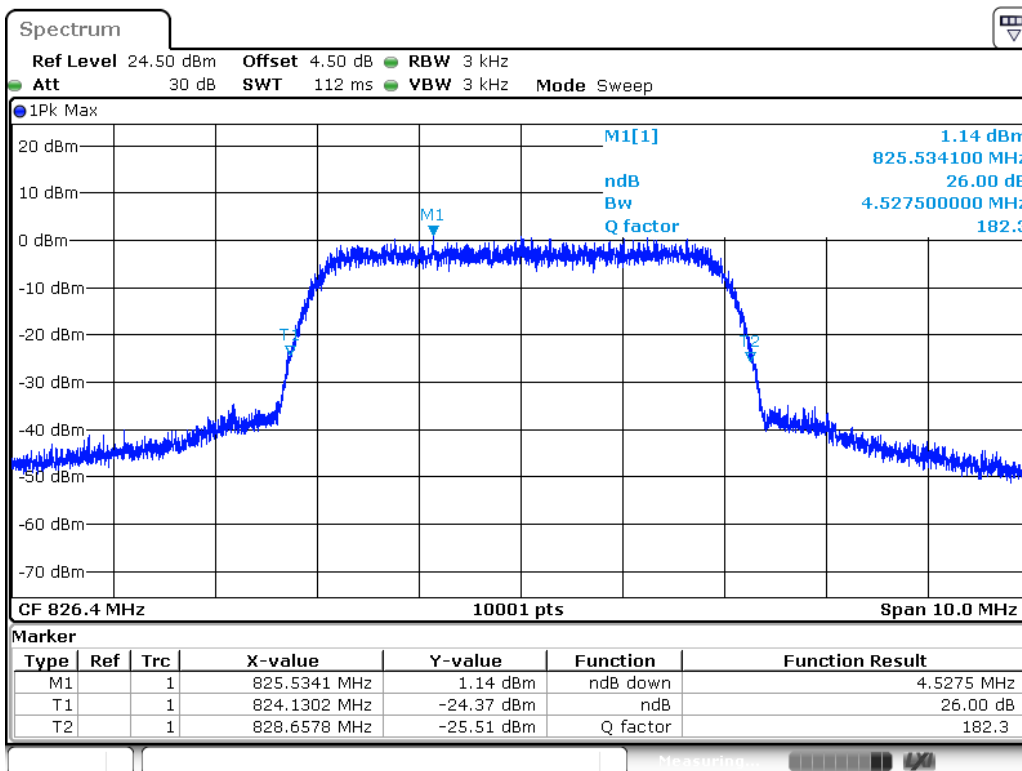

Date: 25 MAY 2017 14:11:23

Figure Channel 4132 (826.40MHz) (99% BW)

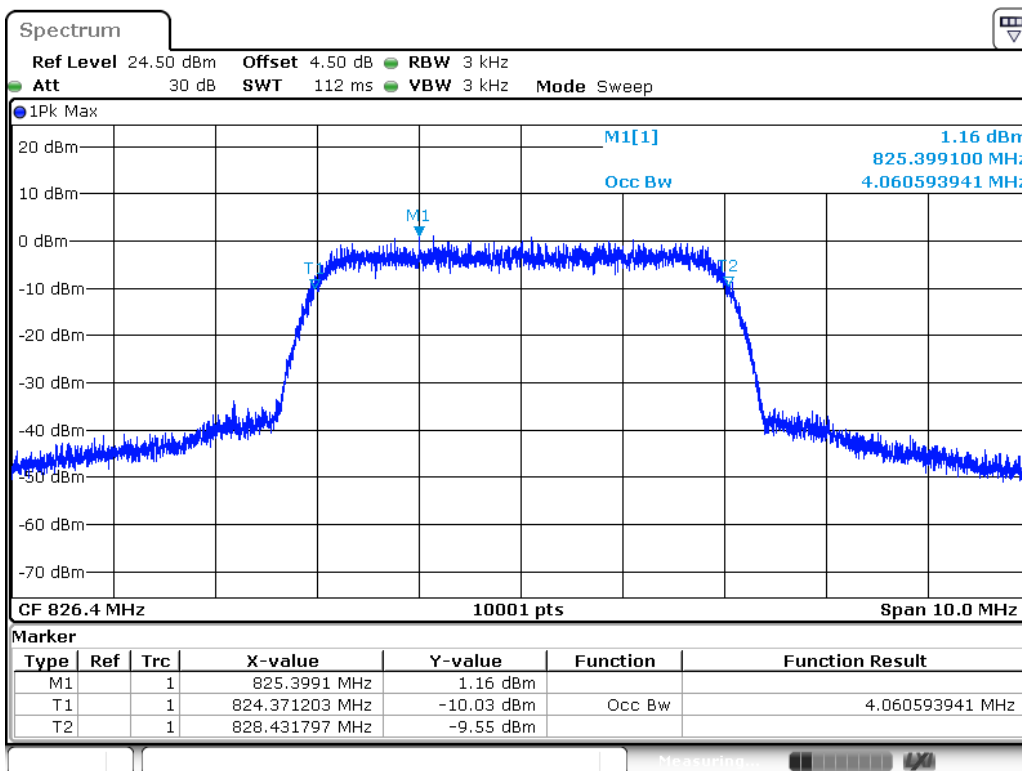

Date: 25 MAY 2017 13:49:31

### Figure Channel 4182 (836.60MHz) (-26dB BW)

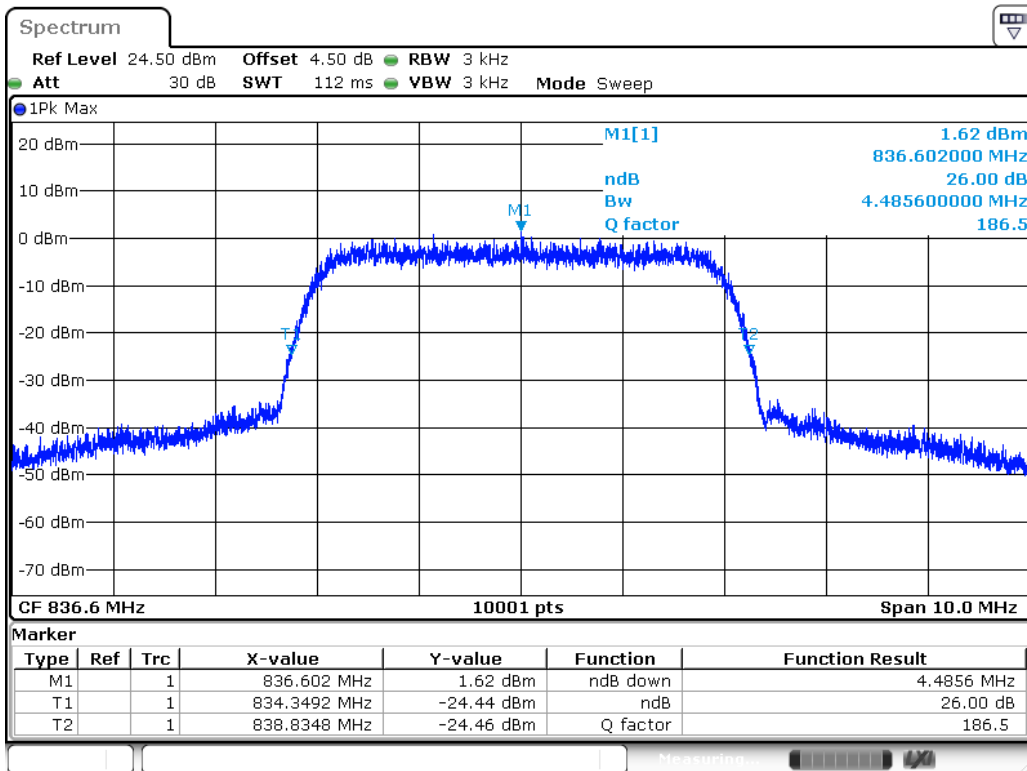

Date: 25 MAY 2017 14:12:49

### Figure Channel 4182 (836.60MHz) (99% BW)

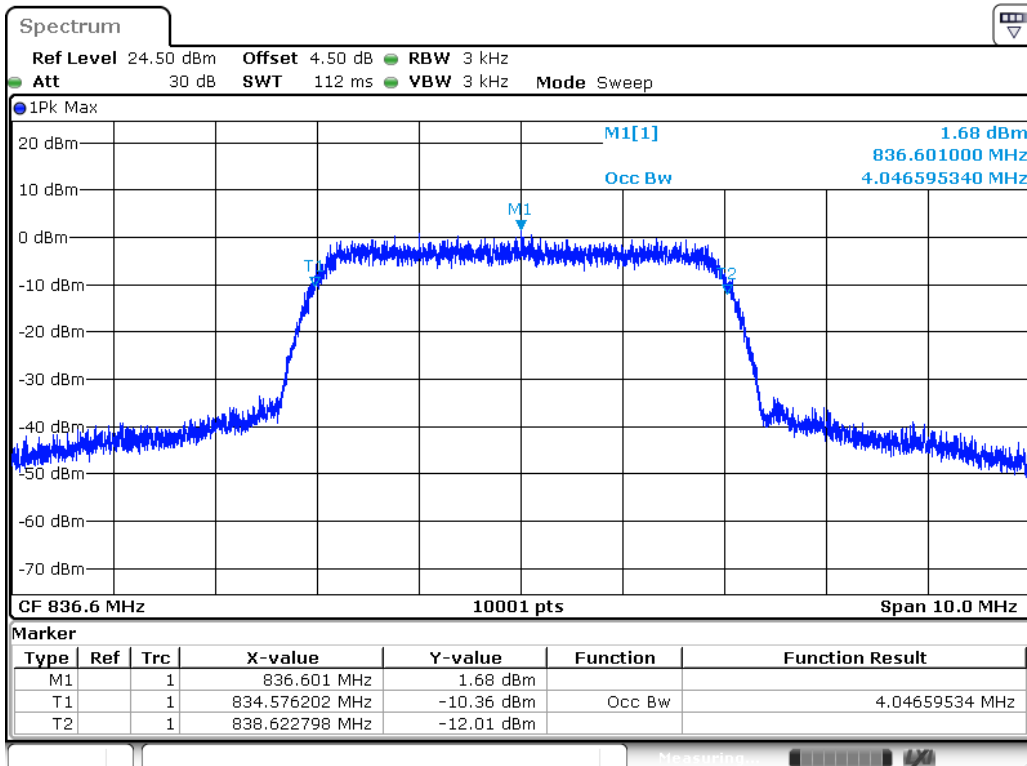

Date: 25 MAY 2017 13:48:24

### Figure Channel 4233(846.60MHz) (-26dB BW)

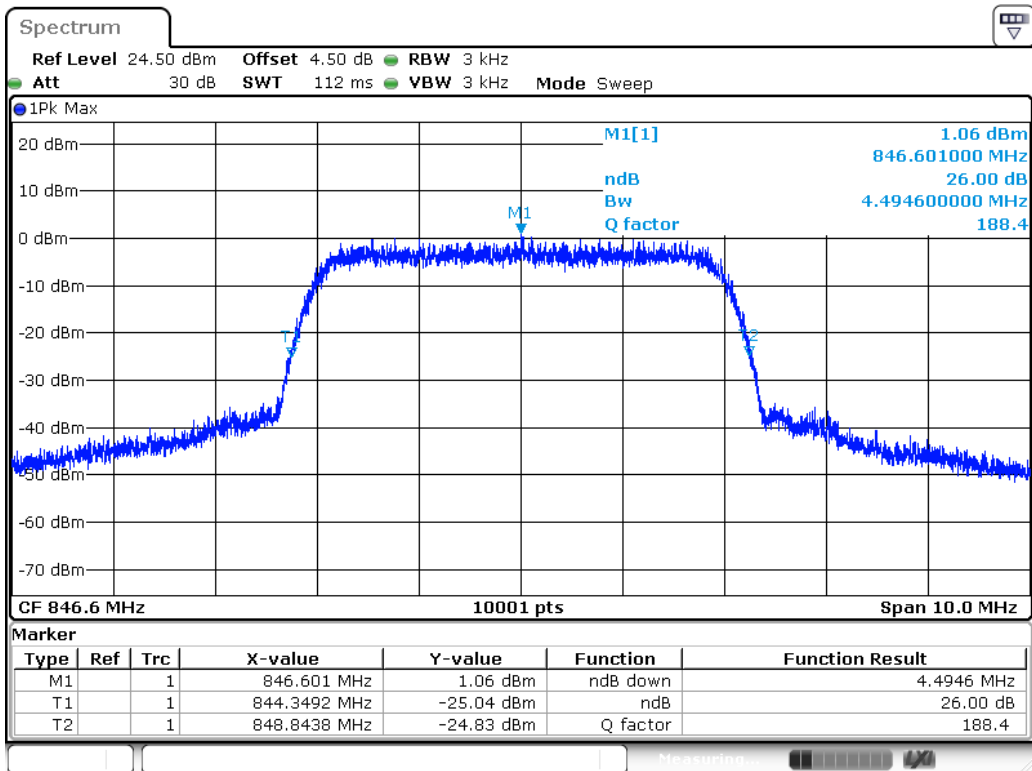

Date: 25 MAY 2017 14:17:20

### Figure Channel 4233(846.60MHz) (99% BW)

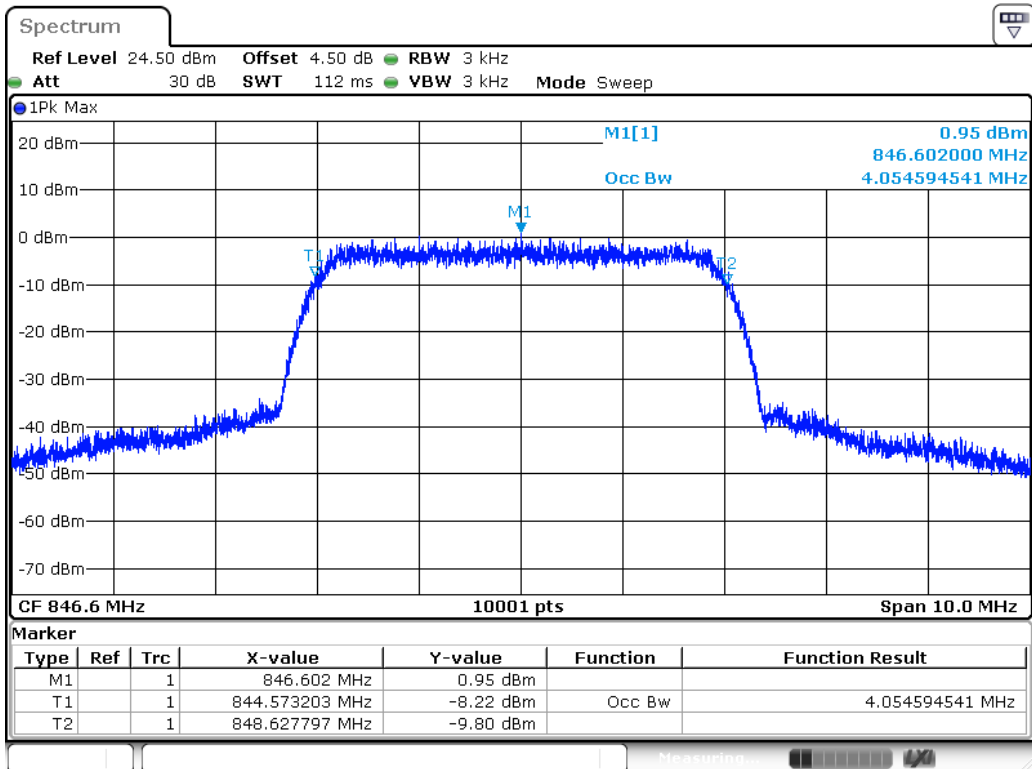

Date: 25 MAY 2017 13:46:56



Product	3G Cellular Alarm Communicator		
Test Item	Occupied Bandwidth		
Test Mode	Mode 7: WCDMA Band 5_HSDPA_Link		
Date of Test	2017/05/25	Test Site	SR10-H

Frequency (MHz)	-26dB BW Measure Level (MHz)	99% BW Measure Level (MHz)	Limit (MHz)
824.2	4.533	4.050	N/A
836.6	4.503	4.049	N/A
848.8	4.520	4.044	N/A

### Figure Channel 4132 (826.40MHz) (-26dB BW)

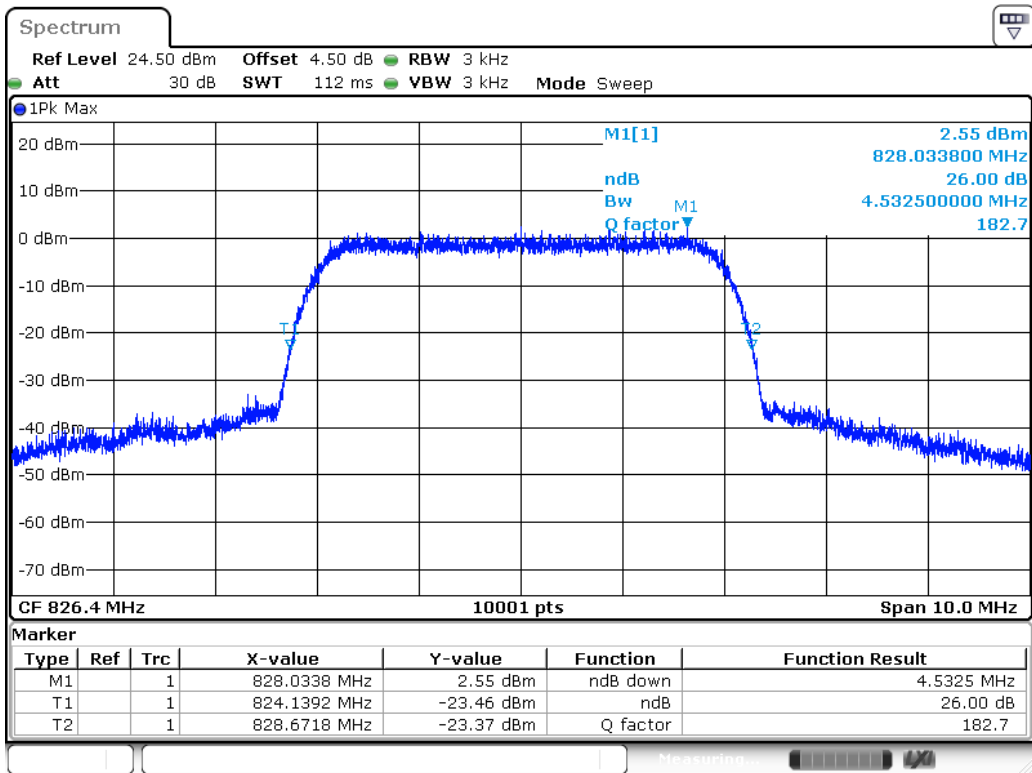

Date: 25 MAY 2017 14:09:25

### Figure Channel 4132 (826.40MHz) (99% BW)

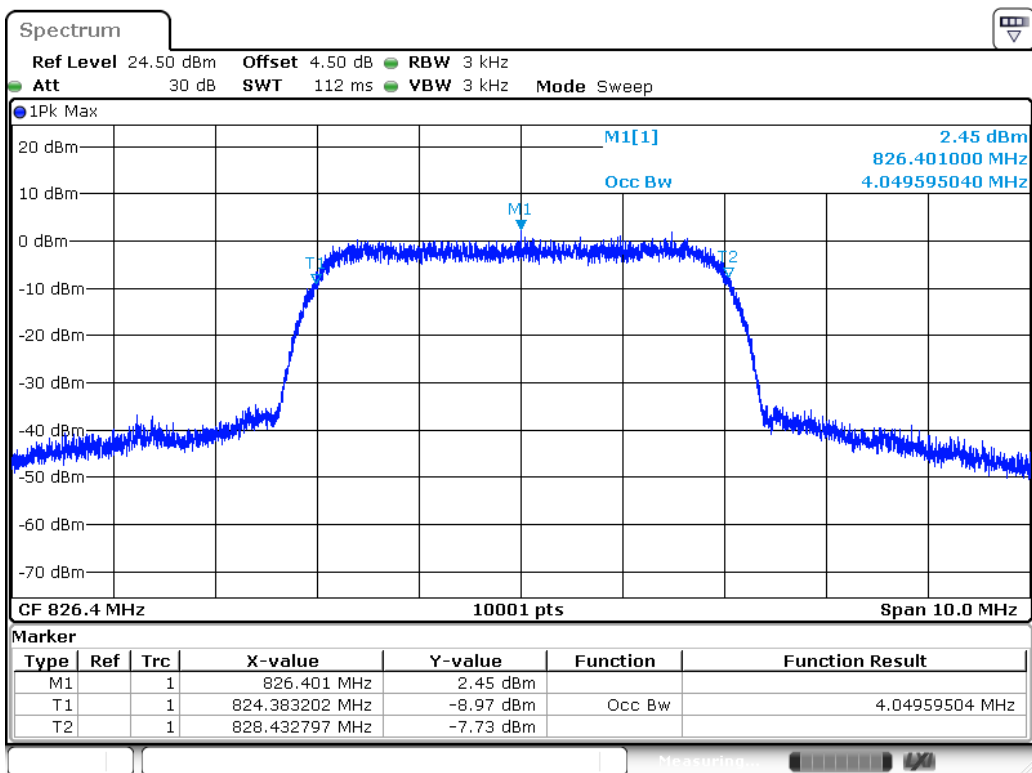

Date: 25 MAY 2017 13:50:58

### Figure Channel 4182 (836.60MHz) (-26dB BW)

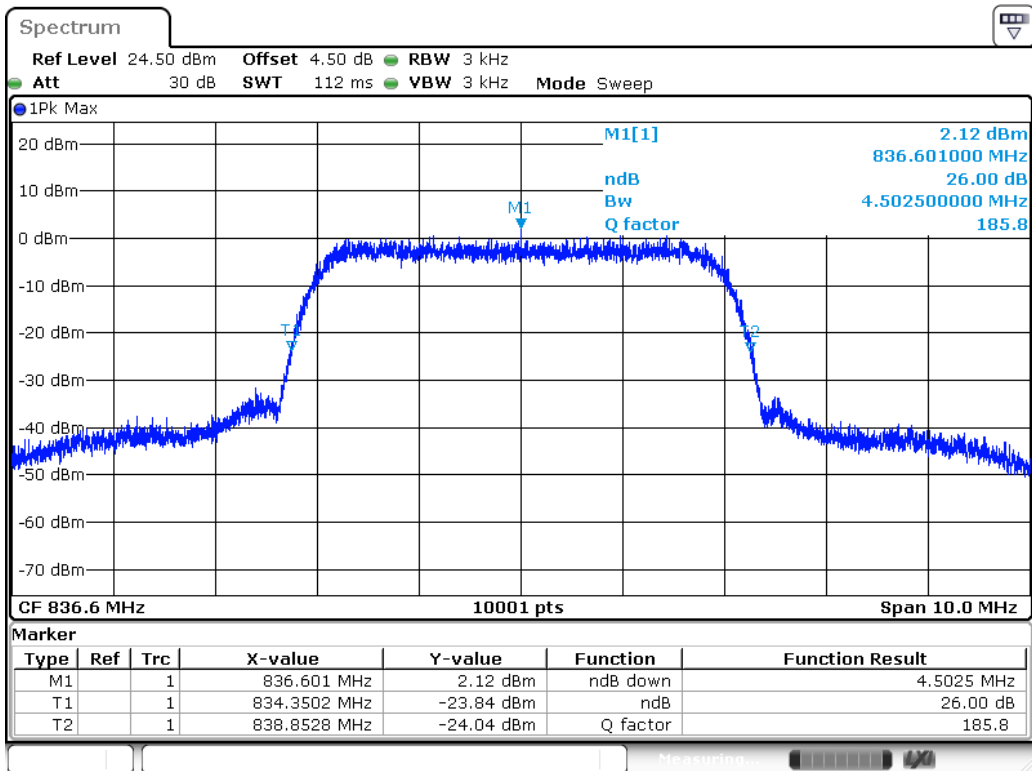

Date: 25 MAY 2017 14:05:05

### Figure Channel 4182 (836.60MHz) (99% BW)

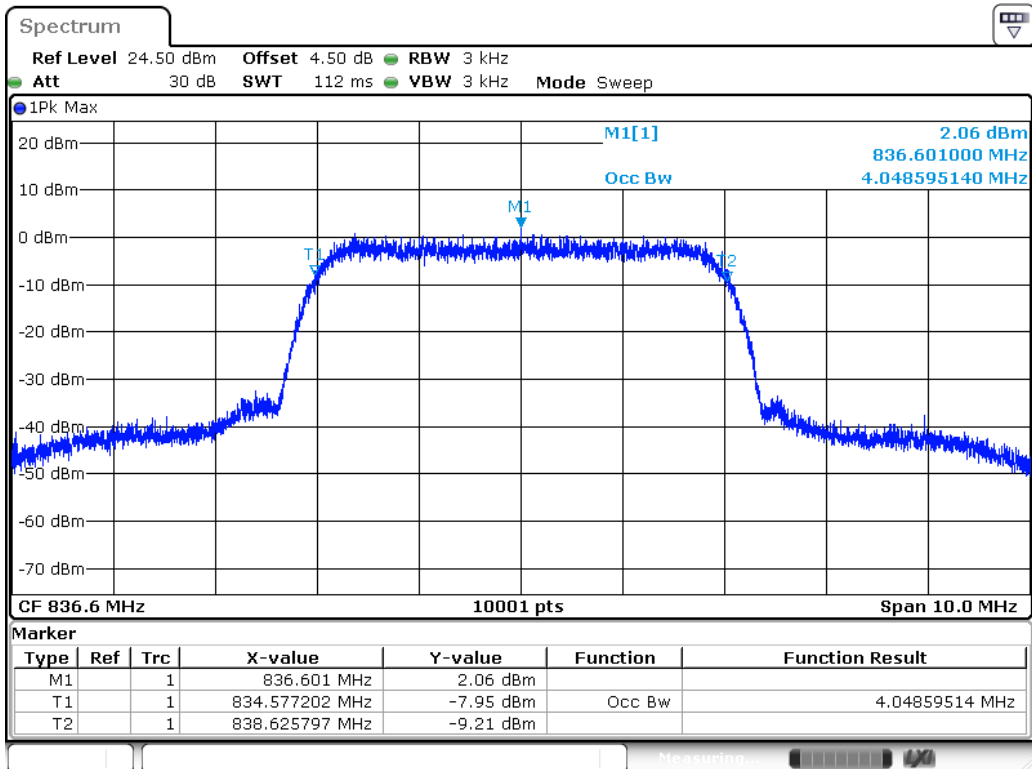

Date: 25 MAY 2017 13:51:56

### Figure Channel 4233(846.60MHz) (-26dB BW)

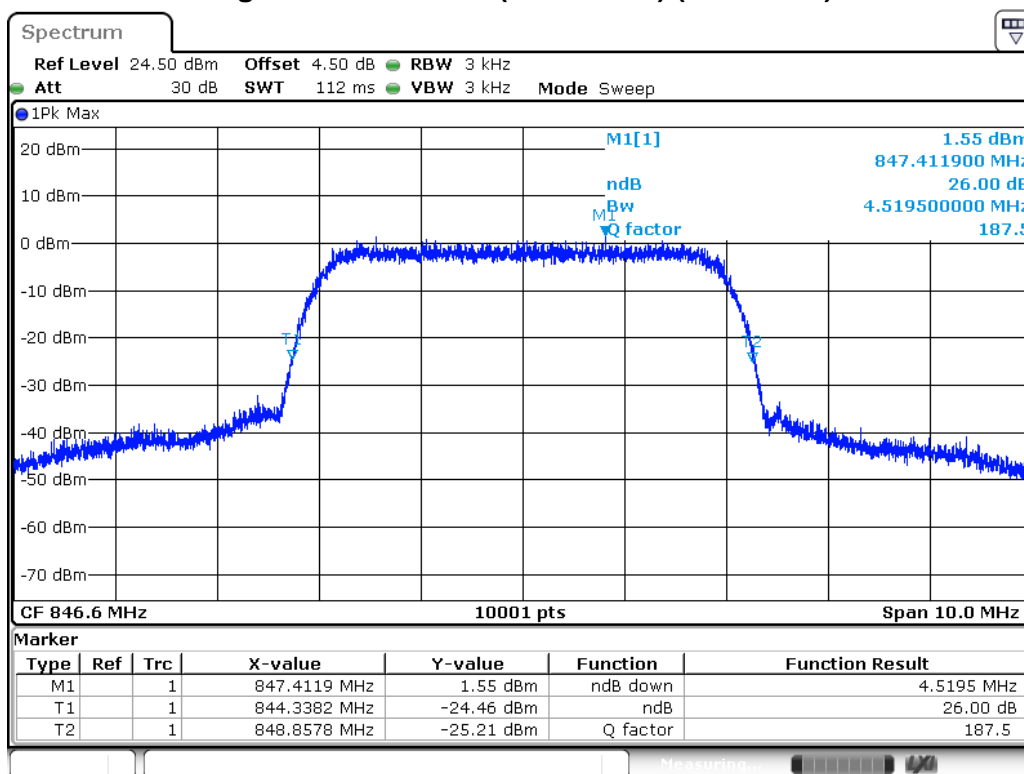

Date: 25 MAY 2017 14:03:46

### Figure Channel 4233(846.60MHz) (99% BW)

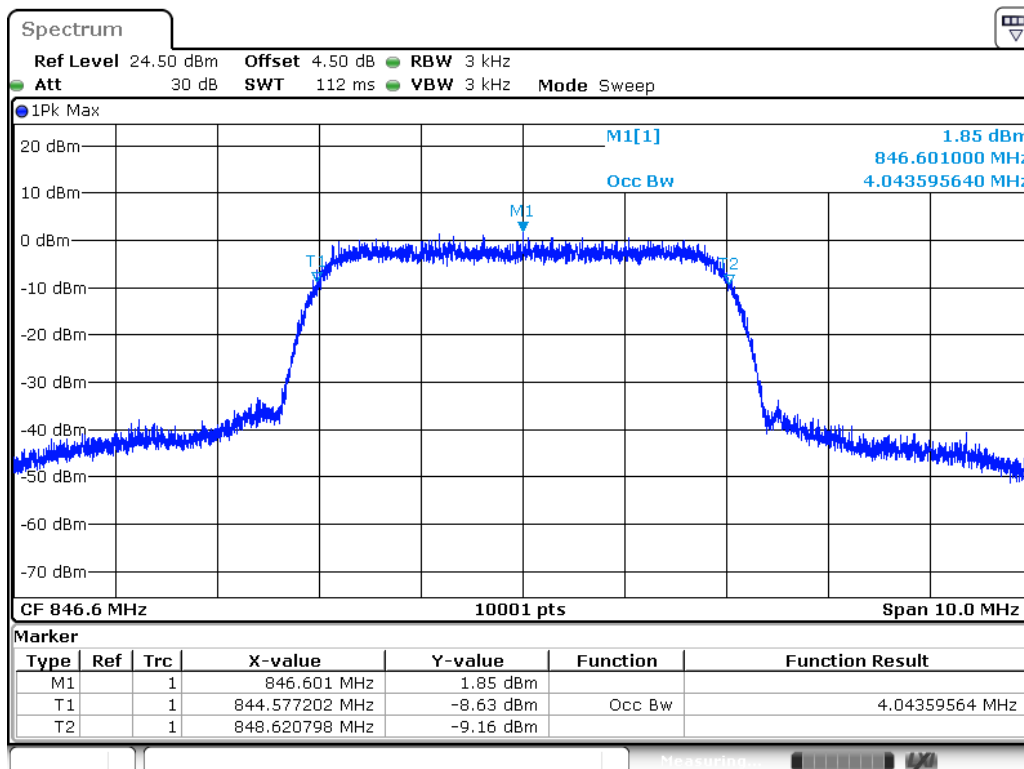

Date: 25 MAY 2017 13:53:15

Product	3G Cellular Alarm Communicator		
Test Item	Occupied Bandwidth		
Test Mode	Mode 8: WCDMA Band 2_Link		
Date of Test	2017/05/25	Test Site	SR10-H

Frequency (MHz)	-26dB BW Measure Level (MHz)	99% BW Measure Level (MHz)	Limit (MHz)
1850.2	4.550	4.047	N/A
1880.0	4.526	4.046	N/A
1909.8	4.534	4.056	N/A

### Figure Channel 9262 (1852.40MHz) (-26dB BW)

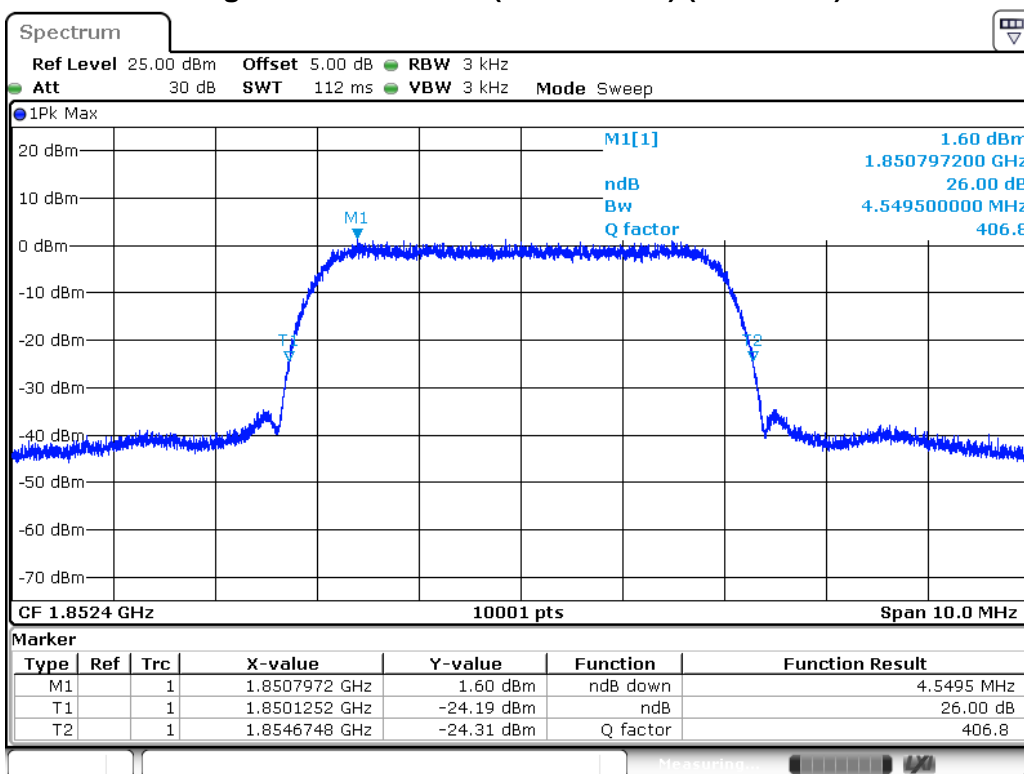

Date: 25 MAY 2017 16:17:27

### Figure Channel 9262 (1852.40MHz) (99% BW)

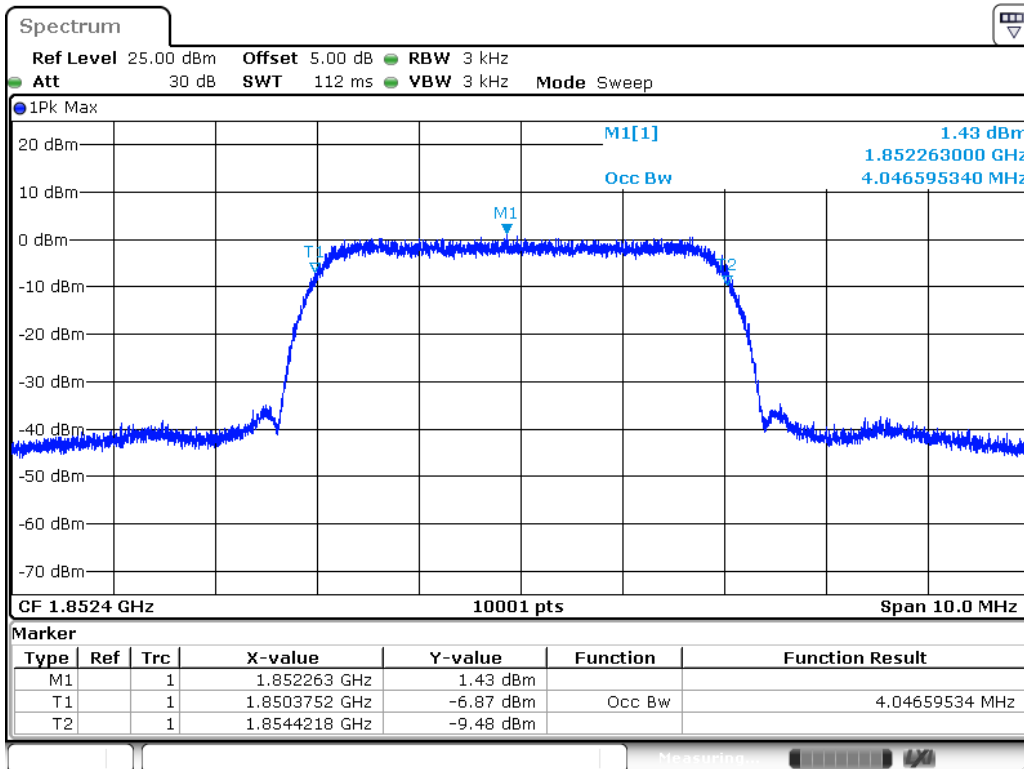

Date: 25 MAY 2017 16:43:37

### Figure Channel 9400 (1880.0MHz) (-26dB BW)

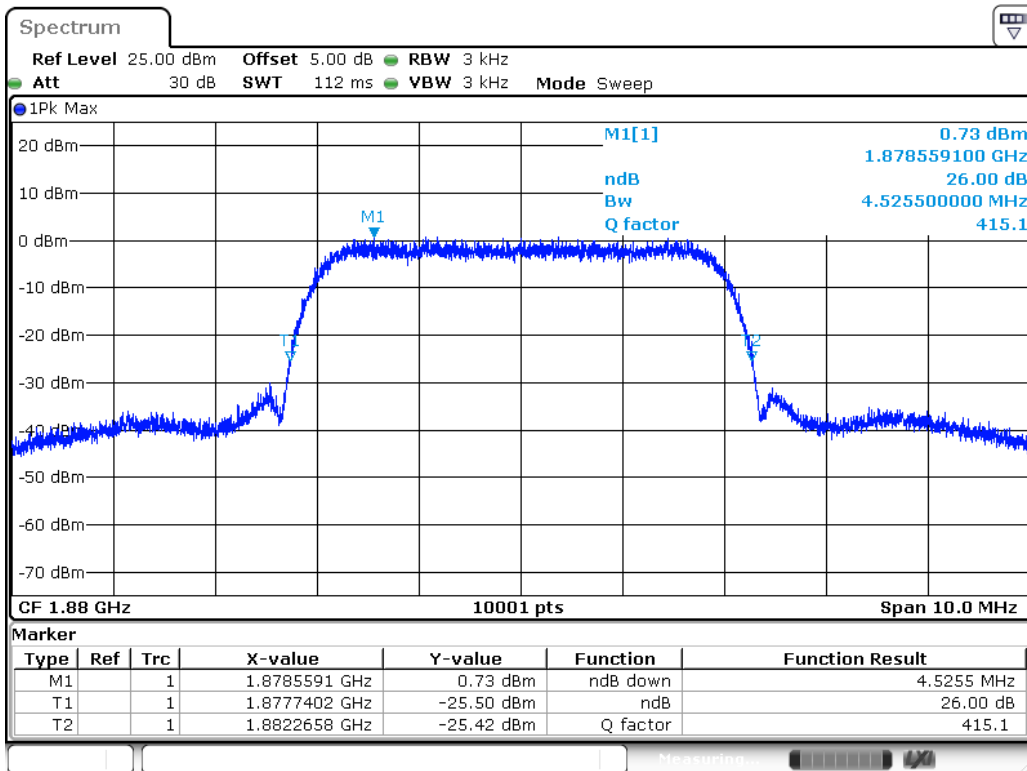

Date: 25 MAY 2017 16:18:32

### Figure Channel 9400 (1880.0MHz) (99% BW)

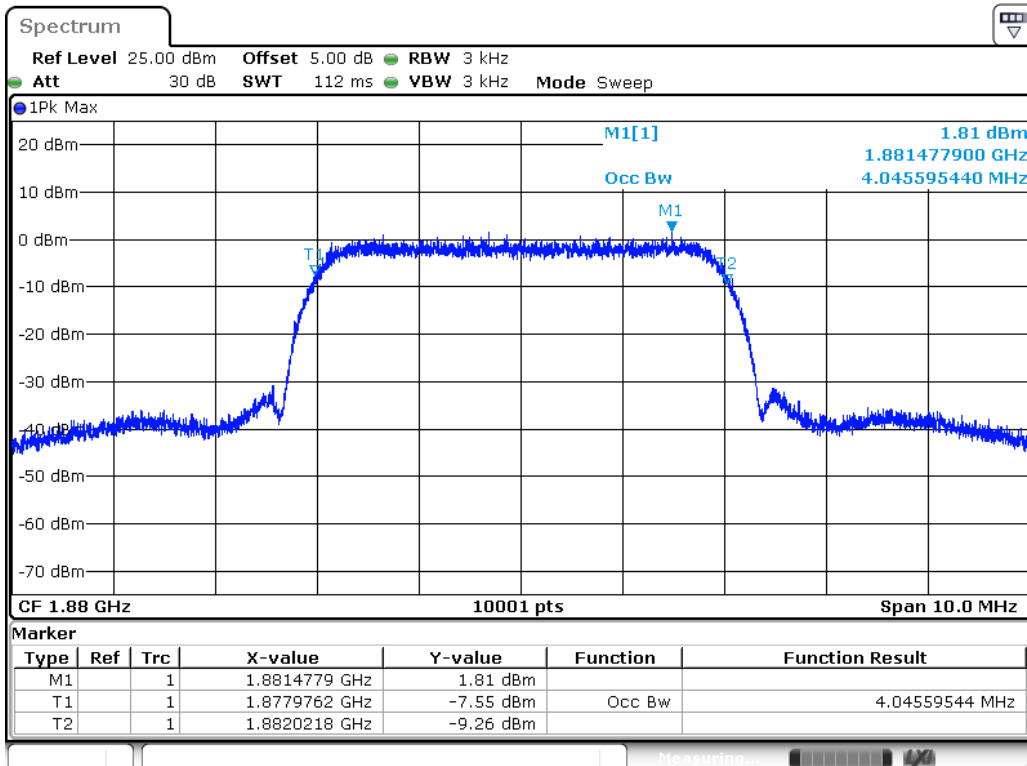

Date: 25 MAY 2017 16:44:32

### Figure Channel 9538 (1907.60MHz) (-26dB BW)

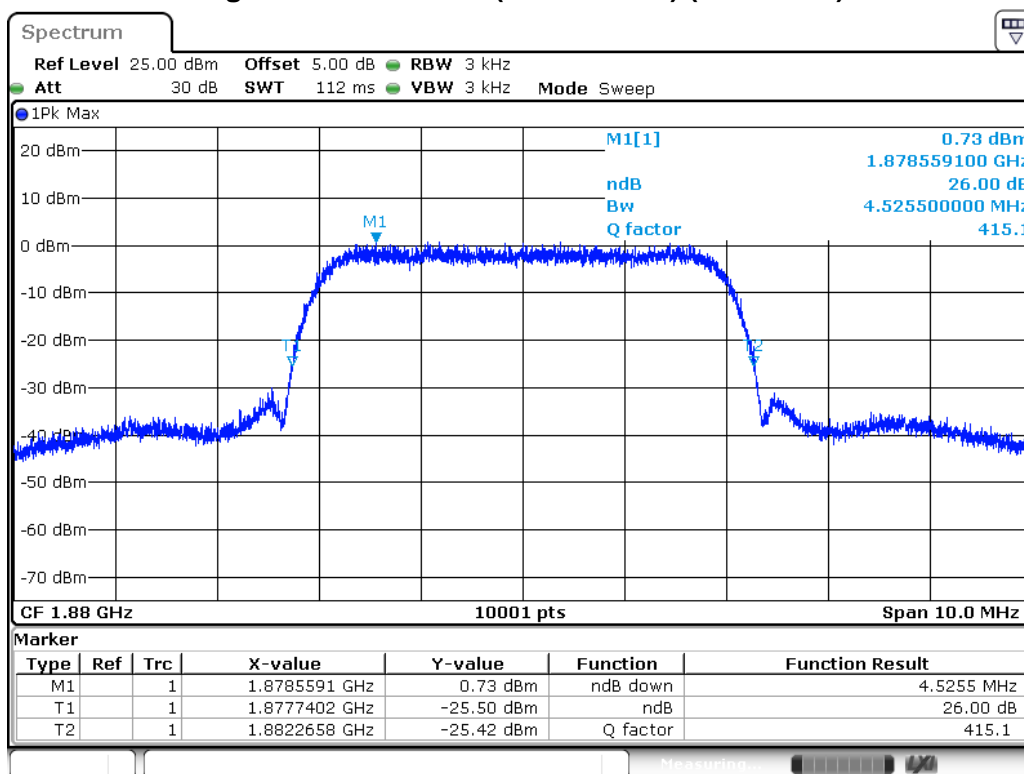

Date: 25 MAY 2017 16:18:32

### Figure Channel 9538 (1907.60MHz) (99% BW)

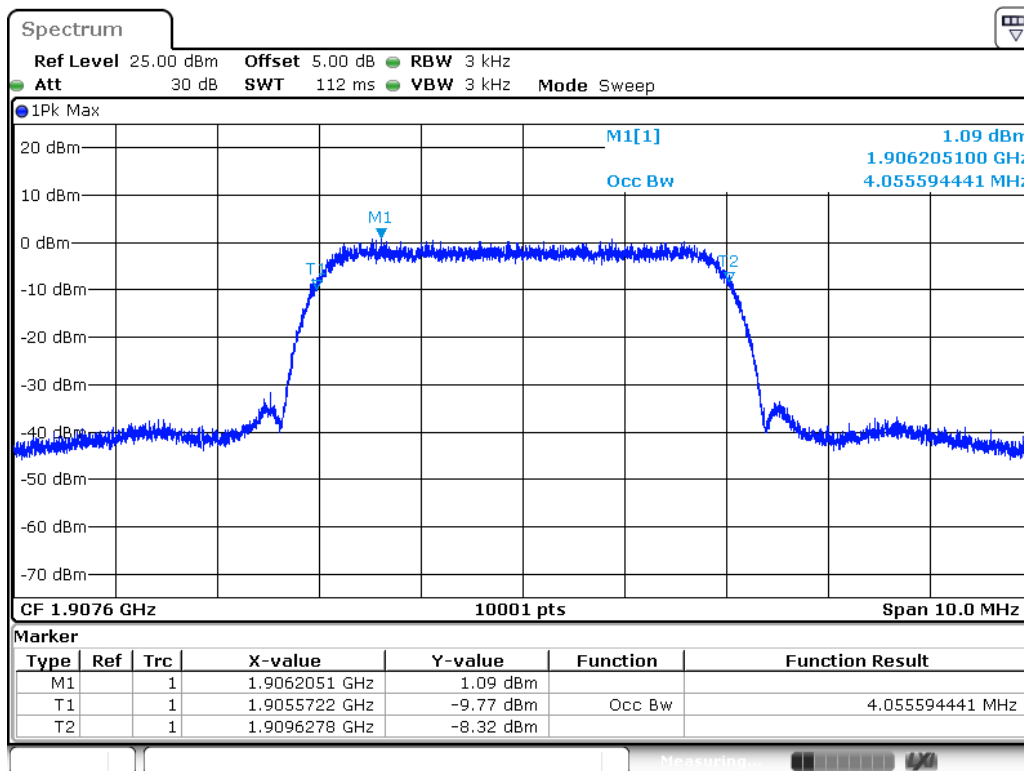

Date: 25 MAY 2017 16:45:46



Product	3G Cellular Alarm Communicator		
Test Item	Occupied Bandwidth		
Test Mode	Mode 9: WCDMA Band 2_HSUPA_Link		
Date of Test	2017/05/25	Test Site	SR10-H

Frequency (MHz)	-26dB BW Measure Level (MHz)	99% BW Measure Level (MHz)	Limit (MHz)
1850.2	4.518	4.049	N/A
1880.0	4.517	4.054	N/A
1909.8	4.501	4.055	N/A

### Figure Channel 9262 (1852.40MHz) (-26dB BW)

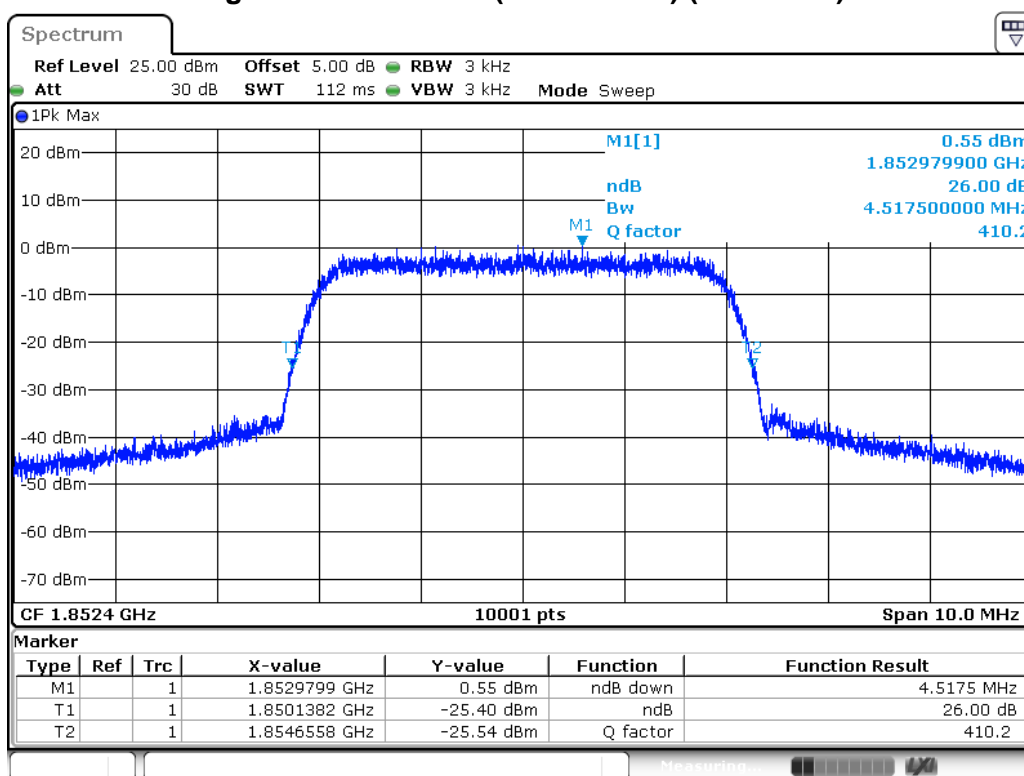

Date: 25 MAY 2017 16:31:39

### Figure Channel 9262 (1852.40MHz) (99% BW)

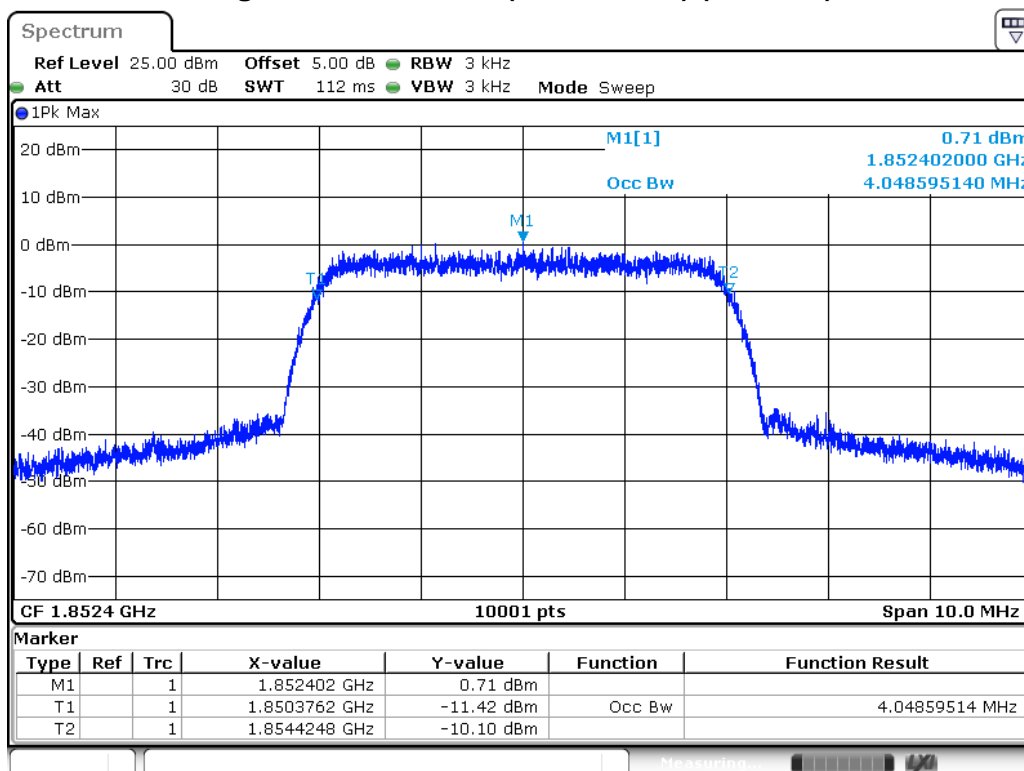

Date: 25 MAY 2017 16:33:19

### Figure Channel 9400 (1880.0MHz) (-26dB BW)

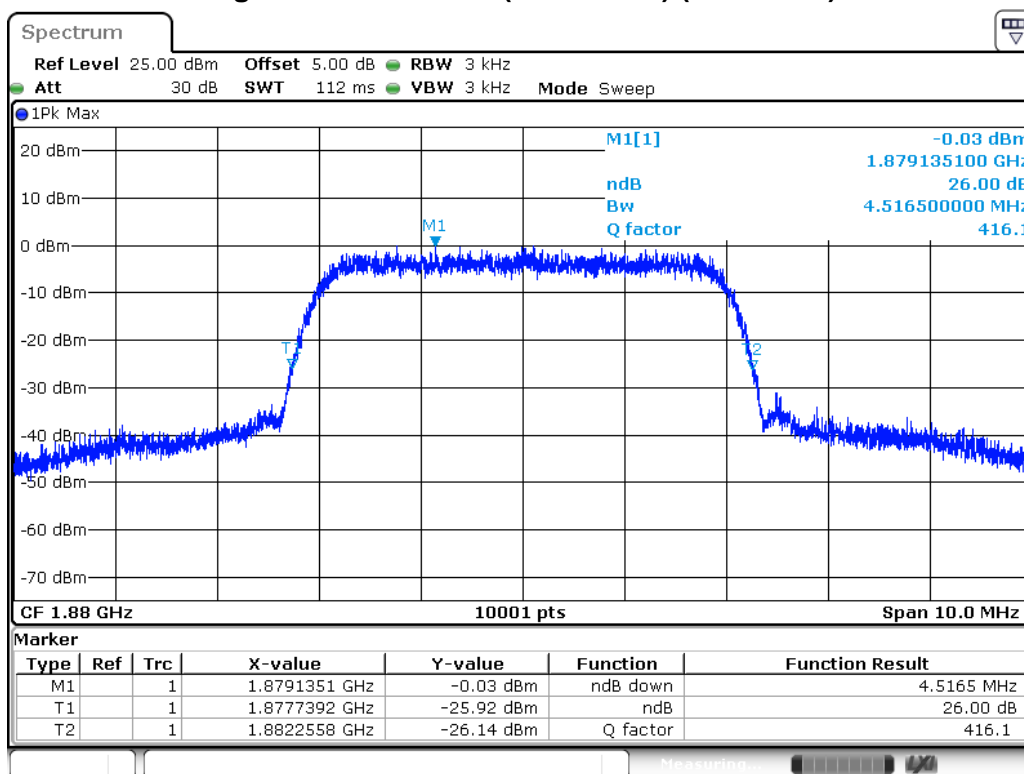

Date: 25 MAY 2017 16:28:09

### Figure Channel 9400 (1880.0MHz) (99% BW)

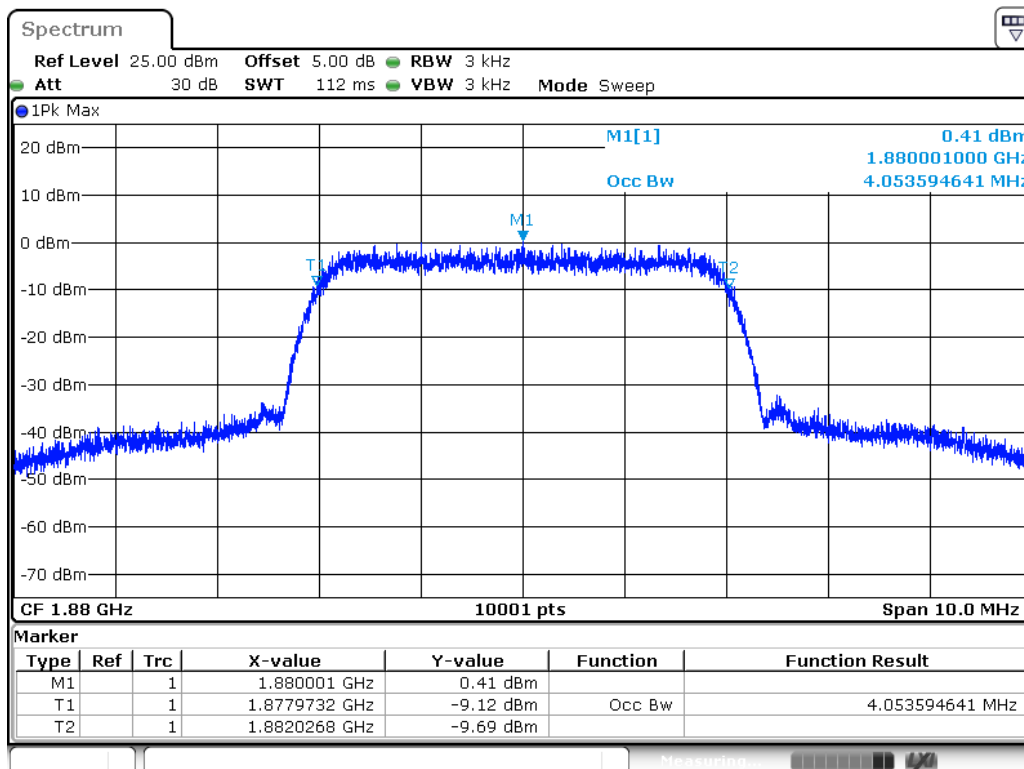

Date: 25 MAY 2017 16:34:59

### Figure Channel 9538 (1907.60MHz) (-26dB BW)

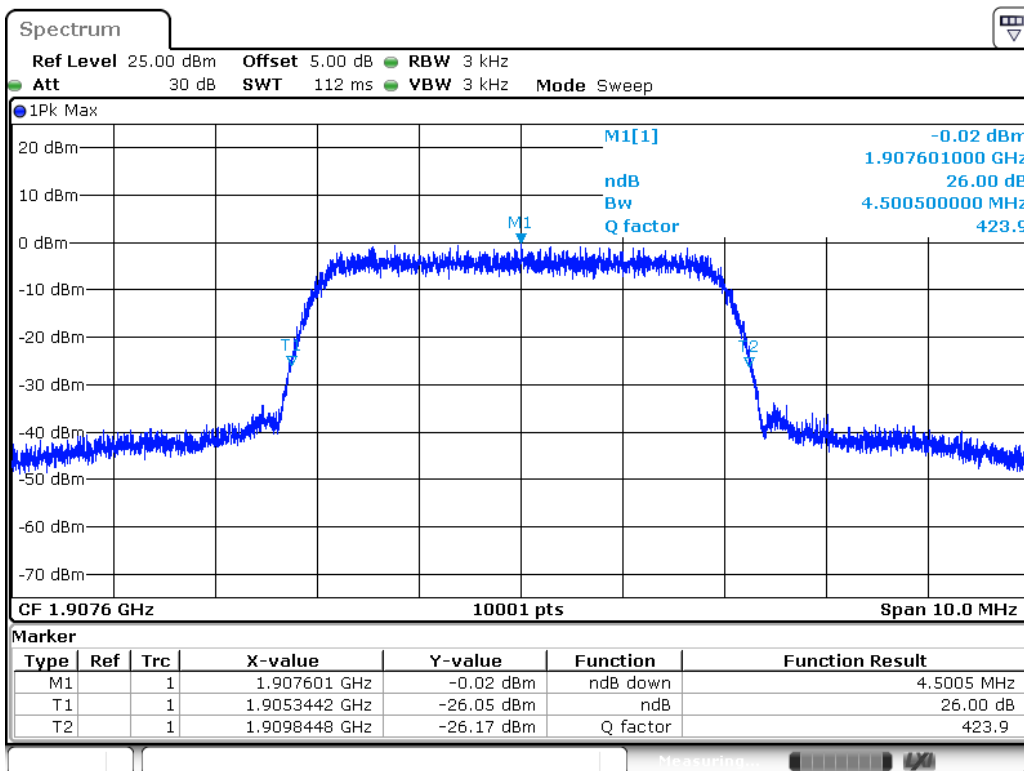

Date: 25 MAY 2017 16:25:22

### Figure Channel 9538 (1907.60MHz) (99% BW)

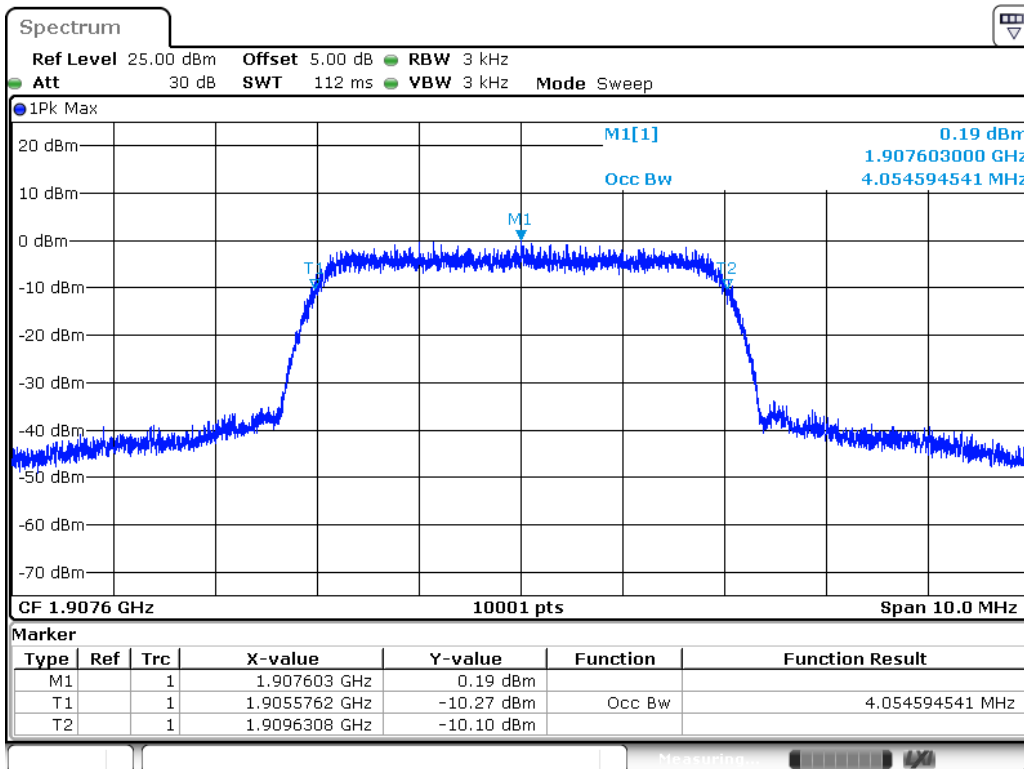

Date: 25 MAY 2017 16:36:58

Product	3G Cellular Alarm Communicator		
Test Item	Occupied Bandwidth		
Test Mode	Mode 10: WCDMA Band 2_HSDPA_Link		
Date of Test	2017/05/25	Test Site	SR10-H

Frequency (MHz)	-26dB BW Measure Level (MHz)	99% BW Measure Level (MHz)	Limit (MHz)
1850.2	4.490	4.048	N/A
1880.0	4.532	4.047	N/A
1909.8	4.525	4.053	N/A

### Figure Channel 9262 (1852.40MHz) (-26dB BW)

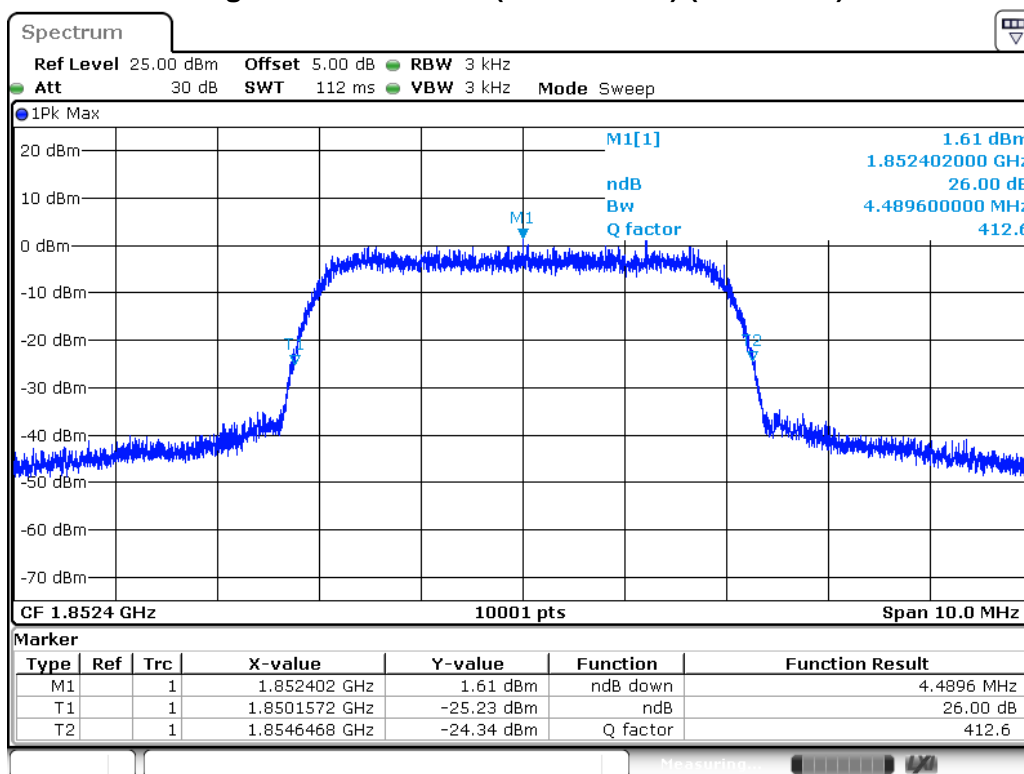

Date: 25 MAY 2017 16:20:48

### Figure Channel 9262 (1852.40MHz) (99% BW)

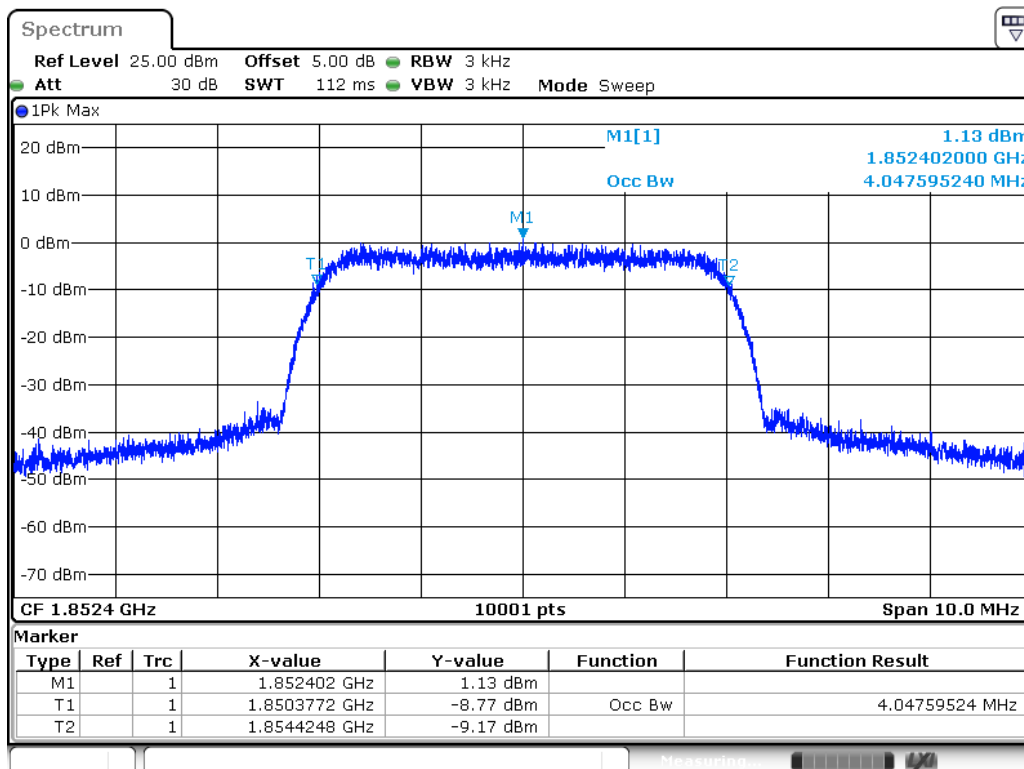

Date: 25 MAY 2017 16:41:40

### Figure Channel 9400 (1880.0MHz) (-26dB BW)

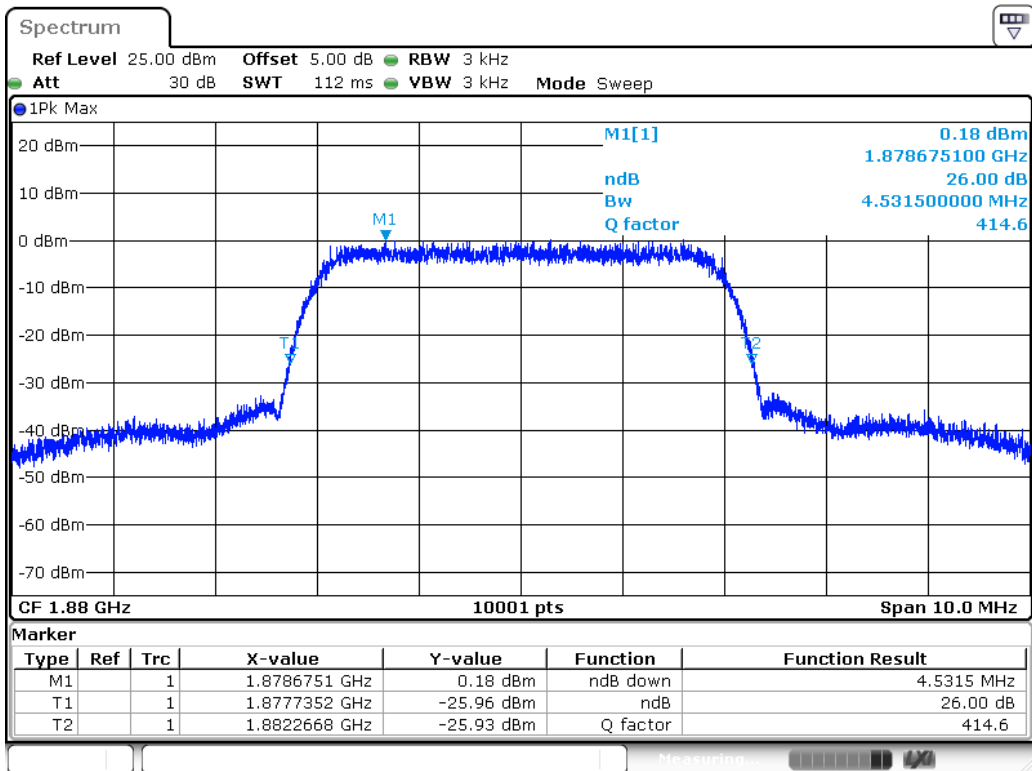

Date: 25 MAY 2017 16:22:36

### Figure Channel 9400 (1880.0MHz) (99% BW)

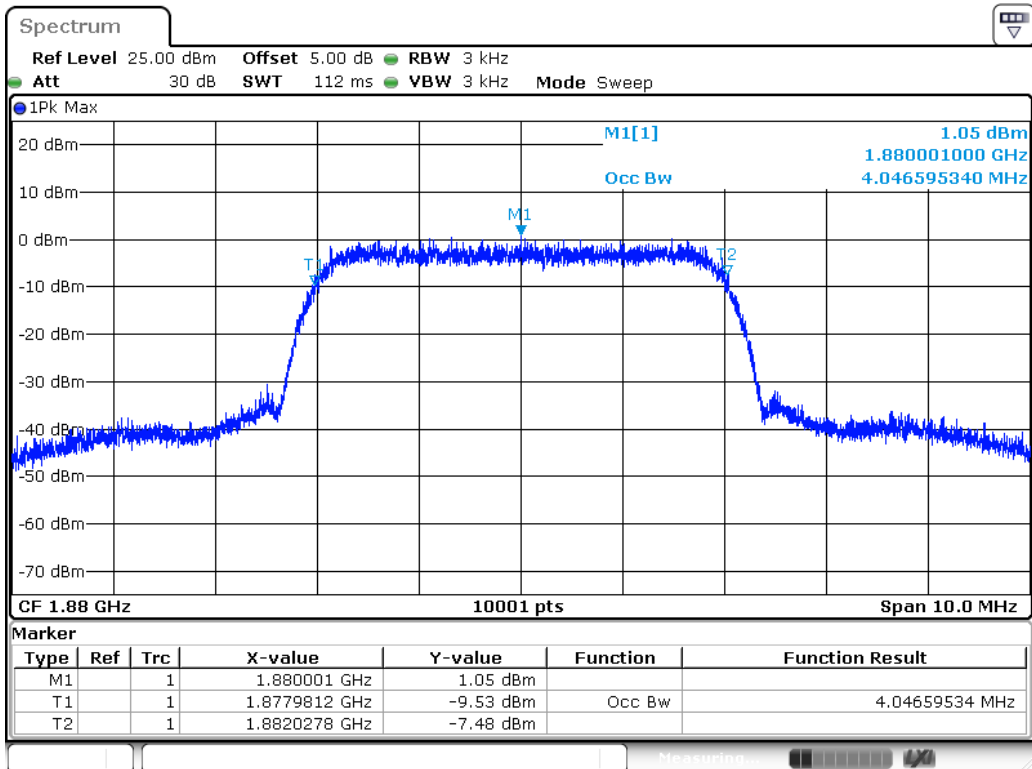

Date: 25 MAY 2017 16:40:25

Figure Channel 9538 (1907.60MHz) (-26dB BW)

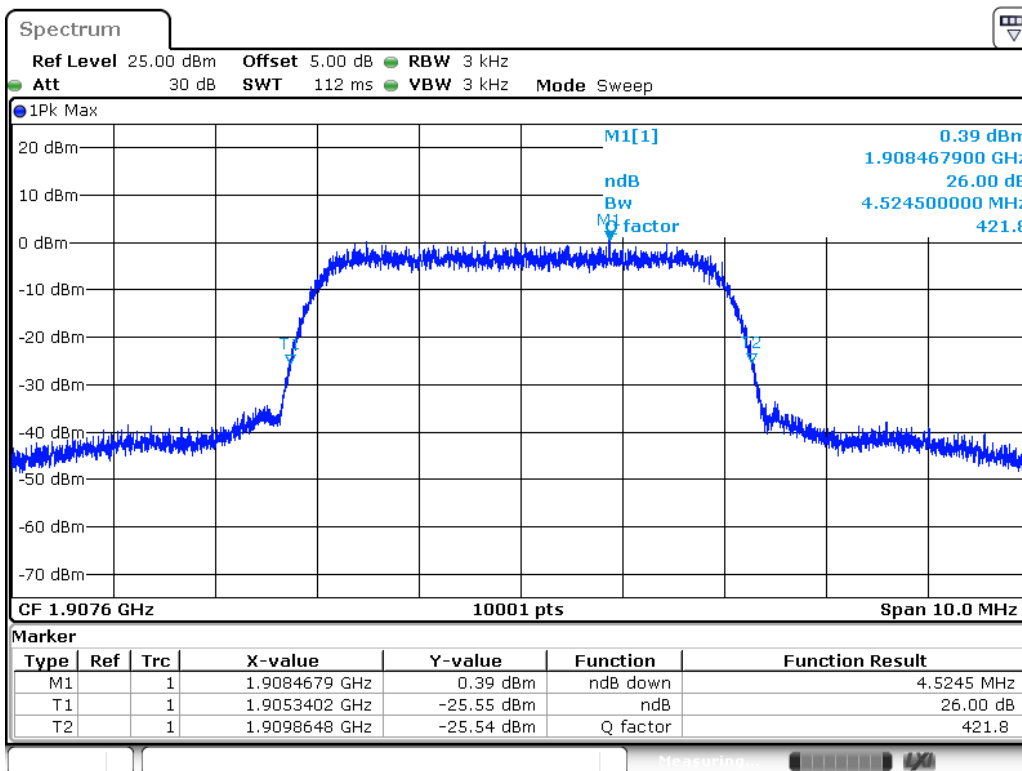

Date: 25 MAY 2017 16:24:12

Figure Channel 9538 (1907.60MHz) (99% BW)

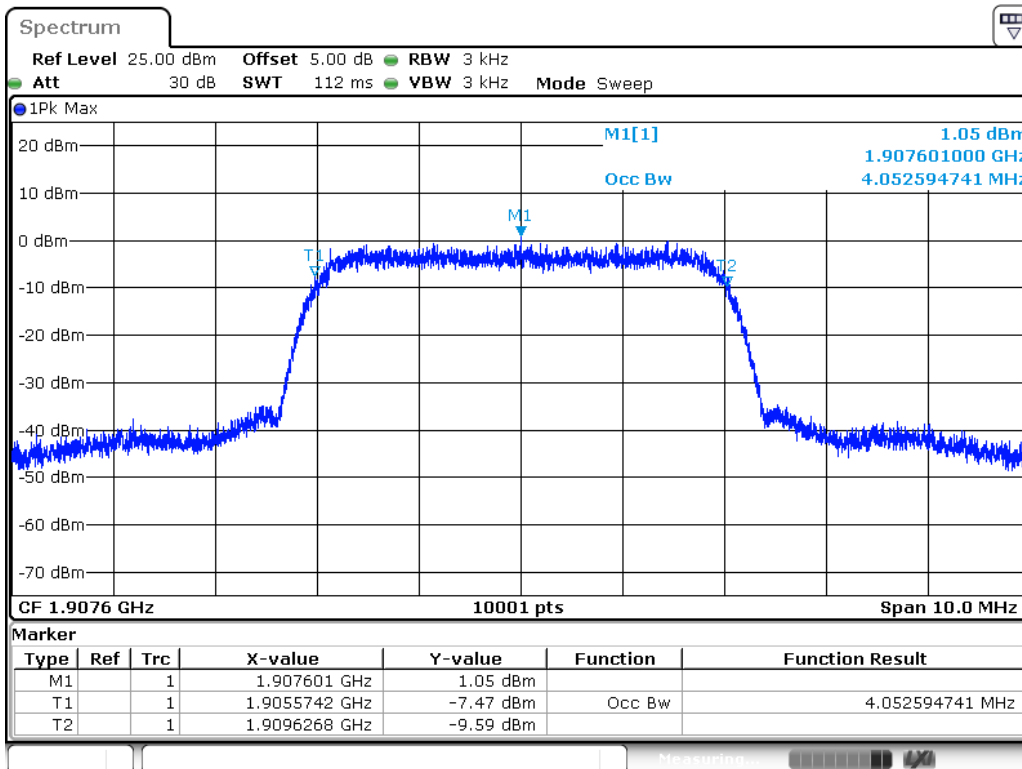

Date: 25 MAY 2017 16:38:15



## 5. Spurious Emission At Antenna Terminals (+/- 1MHz)

### 5.1. Test Equipment

Spurious Emission At Antenna Terminals (+/- 1MHz) / SR10-H

Instrument	Manufacturer	Type No.	Serial No	Cali. Due Date
Signal & Spectrum Analyzer	R&S	FSVA40	101455	2017/11/27
Multisystem UE Tester	Japan radio	NJZ-2000	ET00477	2017/09/19
Directional coupler	Agilent	778D	20402	2017/10/06

Note: All equipment upon which need to be calibrated are with calibration period of 1 year.

### 5.2. Test Setup

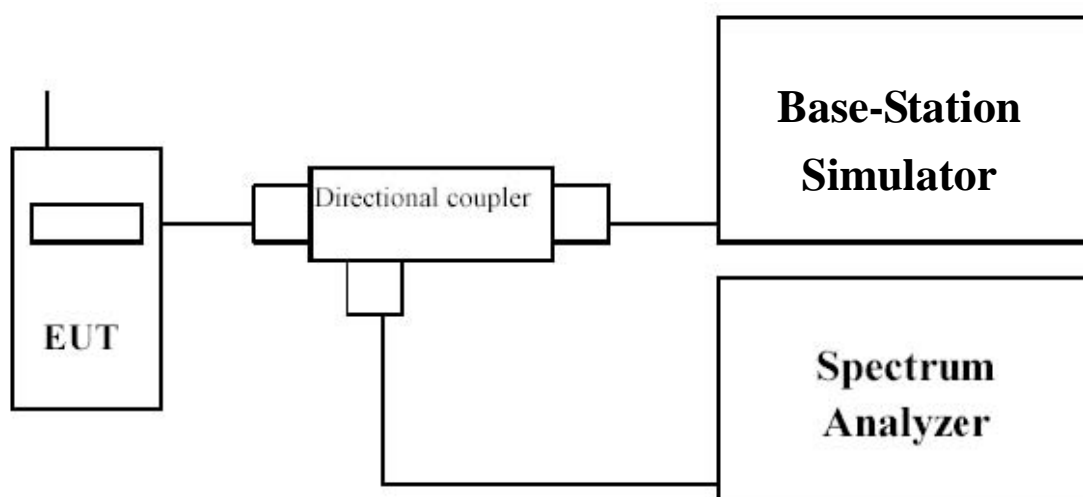

### 5.3. Test Procedure

The power of any emission outside of the authorized operating frequency ranges must be attenuated below the transmitting power (P) by a factor of at least  $43 + 10\log(P)$  dB.

### 5.4. Uncertainty

In the 1MHz bands immediately outside and adjacent to the frequency block a resolution bandwidth of at least one percent of the emission bandwidth of the fundamental emission of the transmitter may be employed to measure the out of band Emissions.

### 5.5. Test Result

Product	3G Cellular Alarm Communicator		
Test Item	Spurious Emission At Antenna Terminals (+/- 1MHz)		
Test Mode	Mode 1: GPRS 850_Link		
Date of Test	2017/05/25	Test Site	SR10-H

Figure Channel 128 (824.20MHz)

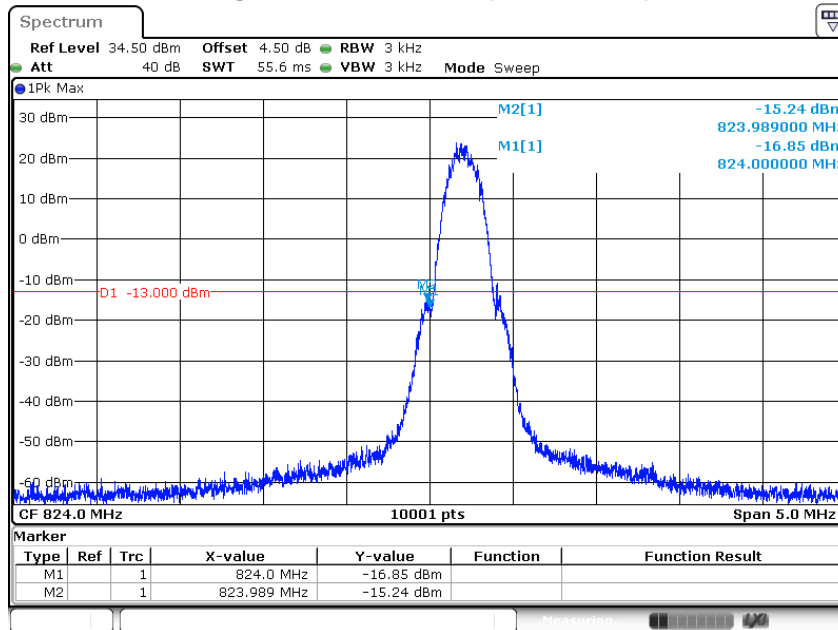

Date: 25 MAY 2017 18:11:00

Figure Channel 251 (848.80MHz)

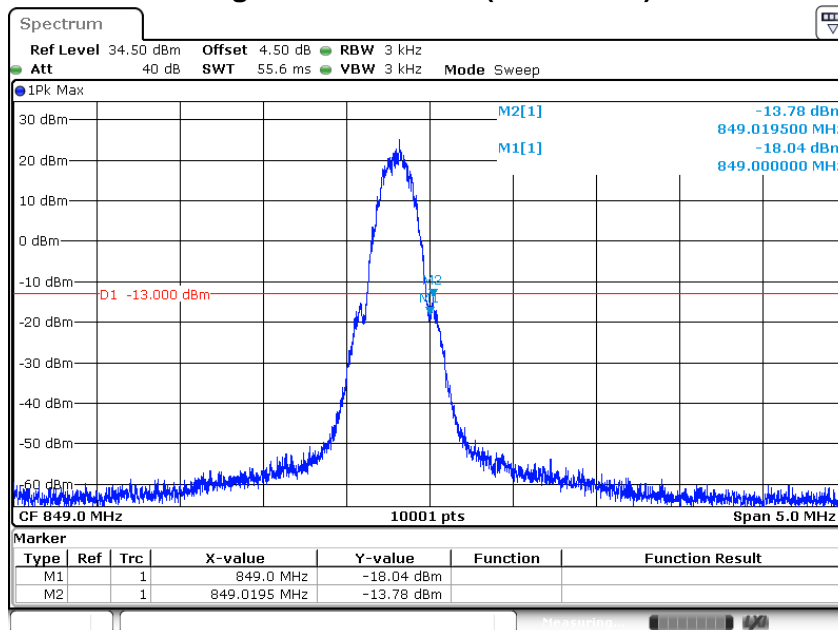

Date: 25 MAY 2017 18:08:45

Product	3G Cellular Alarm Communicator		
Test Item	Spurious Emission At Antenna Terminals (+/- 1MHz)		
Test Mode	Mode 2: GPRS 1900_Link		
Date of Test	2017/05/25	Test Site	SR10-H

Figure Channel 512 (1850.20MHz)

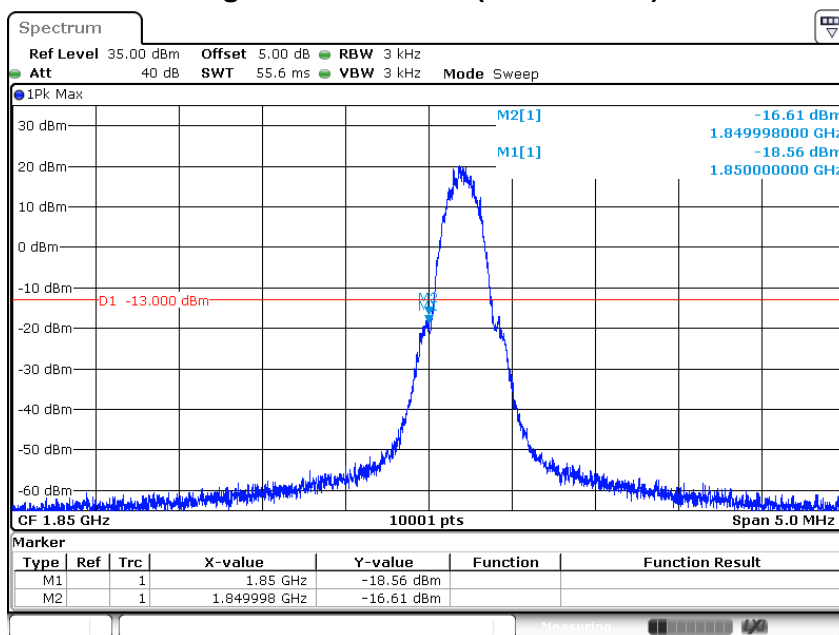

Date: 25 MAY 2017 17:20:18

Figure Channel 810 (1909.80MHz)

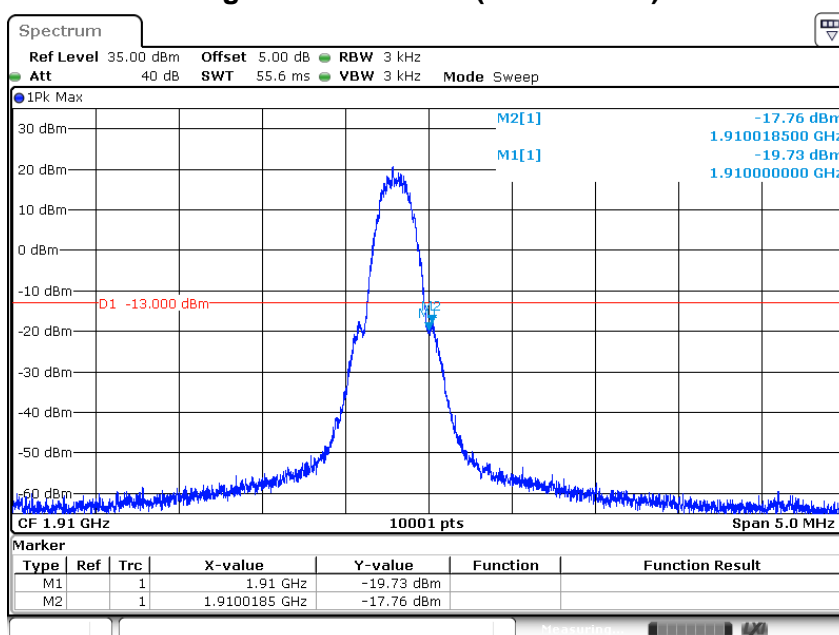

Date: 25 MAY 2017 17:18:31

Product	3G Cellular Alarm Communicator		
Test Item	Spurious Emission At Antenna Terminals (+/- 1MHz)		
Test Mode	Mode 3: EGPRS 850_Link		
Date of Test	2017/05/25	Test Site	SR10-H

Figure Channel 128 (824.20MHz)

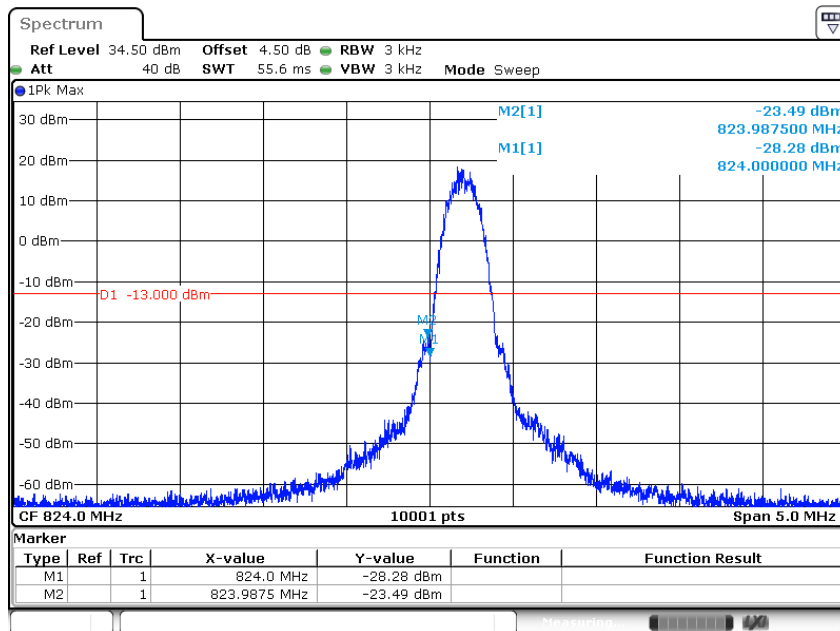

Date: 25 MAY 2017 18:04:27

Figure Channel 251 (848.80MHz)

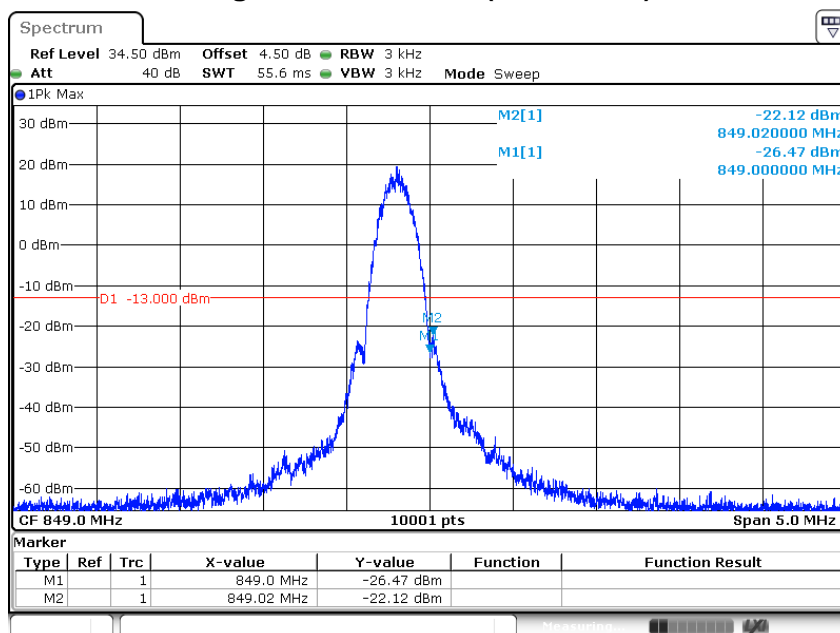

Date: 25 MAY 2017 18:05:58

Product	3G Cellular Alarm Communicator		
Test Item	Spurious Emission At Antenna Terminals (+/- 1MHz)		
Test Mode	Mode 4: EGPRS 1900_Link		
Date of Test	2017/05/25	Test Site	SR10-H

Figure Channel 512 (1850.20MHz)

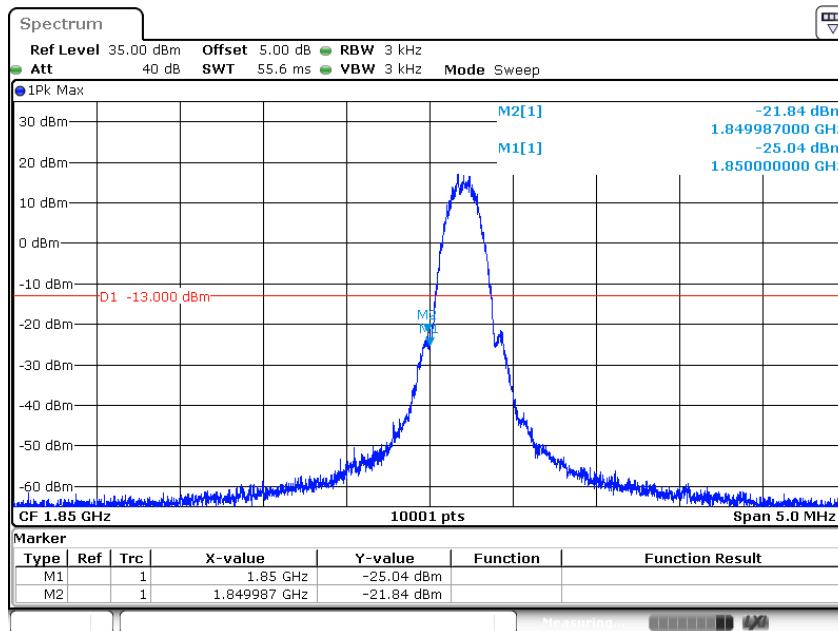

Date: 25 MAY 2017 17:38:05

Figure Channel 810 (1909.80MHz)

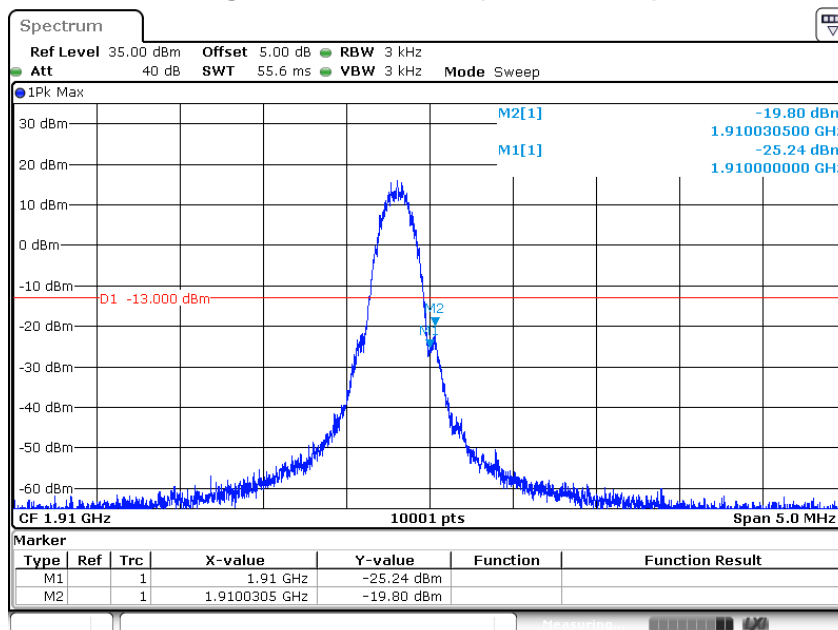

Date: 25 MAY 2017 17:39:58

Product	3G Cellular Alarm Communicator		
Test Item	Spurious Emission At Antenna Terminals (+/- 1MHz)		
Test Mode	Mode 5: WCDMA Band 5_Link		
Date of Test	2017/05/25	Test Site	SR10-H

Figure Channel 4132 (826.40MHz)

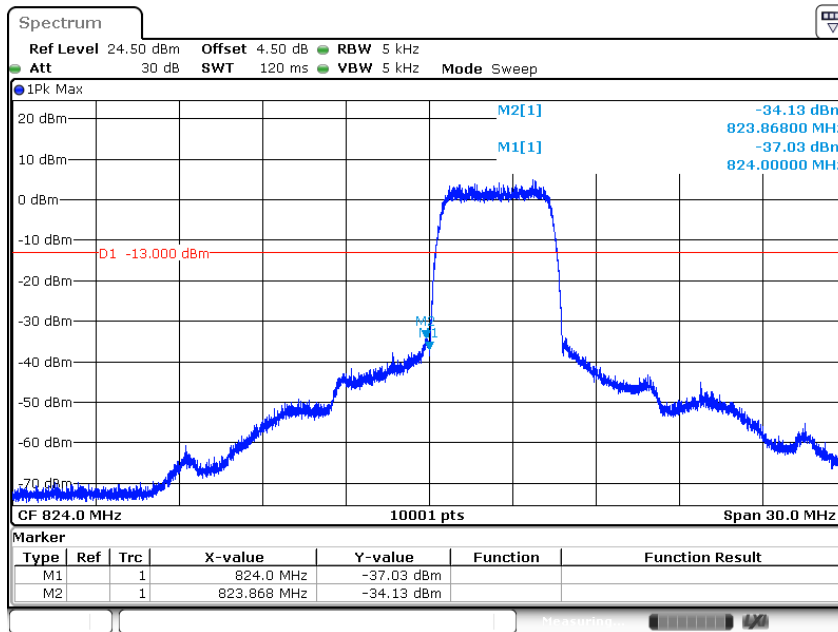

Date: 25 MAY 2017 14:43:32

Figure Channel 251 (846.60MHz)

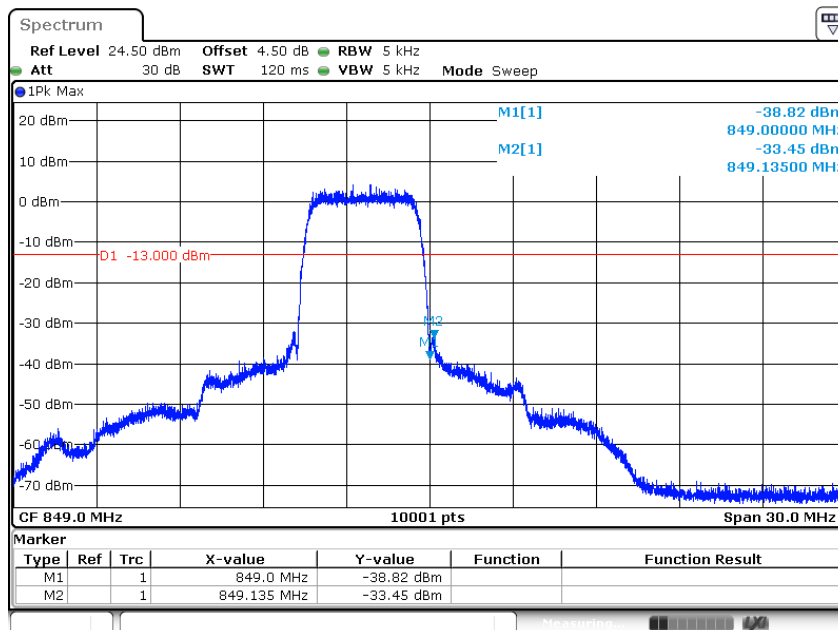

Date: 25 MAY 2017 14:42:02

Product	3G Cellular Alarm Communicator		
Test Item	Spurious Emission At Antenna Terminals (+/- 1MHz)		
Test Mode	Mode 6: WCDMA Band 5_HSUPA_Link		
Date of Test	2017/05/25	Test Site	SR10-H

Figure Channel 4132 (826.40MHz)

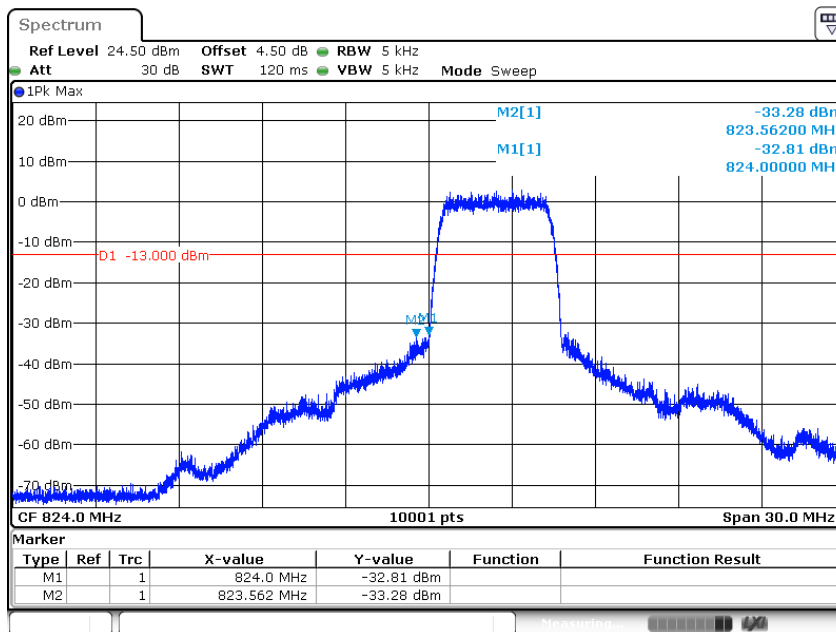

Date: 25 MAY 2017 14:45:24

Figure Channel 251 (846.60MHz)

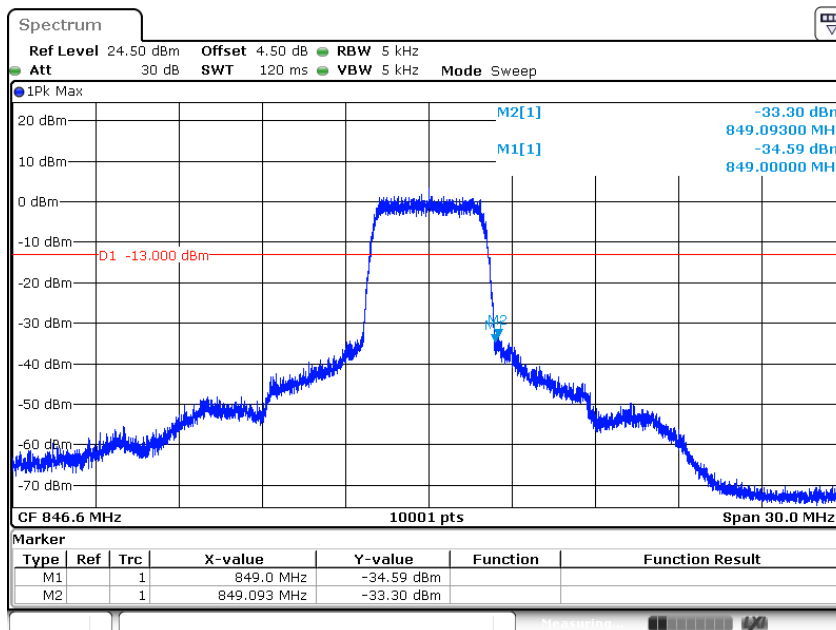

Date: 25 MAY 2017 14:46:52

Product	3G Cellular Alarm Communicator		
Test Item	Spurious Emission At Antenna Terminals (+/- 1MHz)		
Test Mode	Mode 7: WCDMA Band 5_HSDPA_Link		
Date of Test	2017/05/25	Test Site	SR10-H

Figure Channel 4132 (826.40MHz)

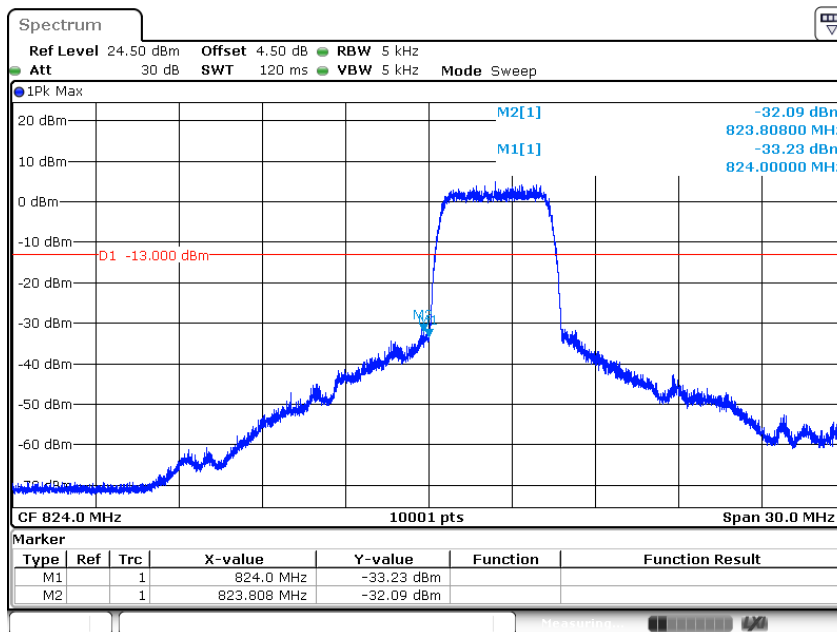

Date: 25 MAY 2017 15:17:42

Figure Channel 251 (846.60MHz)

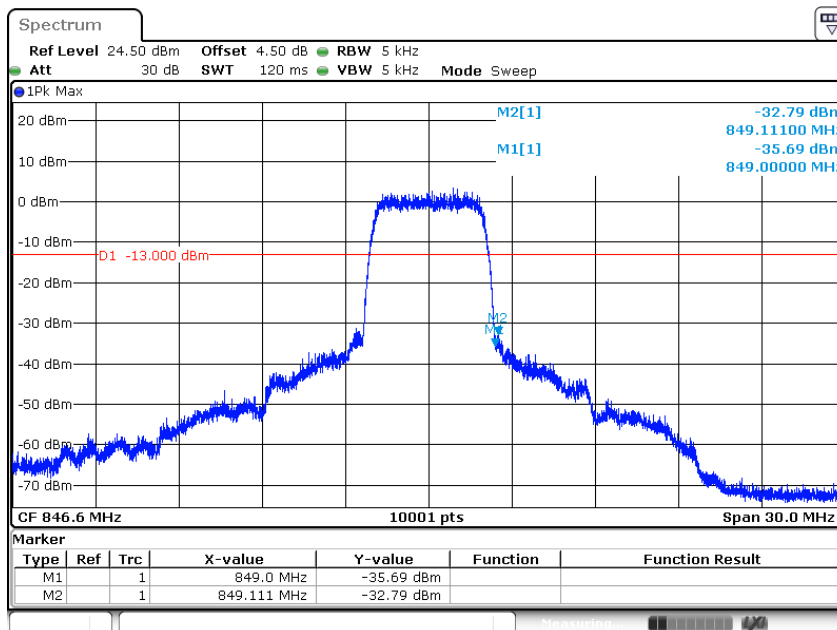

Date: 25 MAY 2017 14:48:34



Product	3G Cellular Alarm Communicator		
Test Item	Spurious Emission At Antenna Terminals (+/- 1MHz)		
Test Mode	Mode 8: WCDMA Band 2_Link		
Date of Test	2017/05/25	Test Site	SR10-H

Figure Channel 9262 (1852.40MHz)

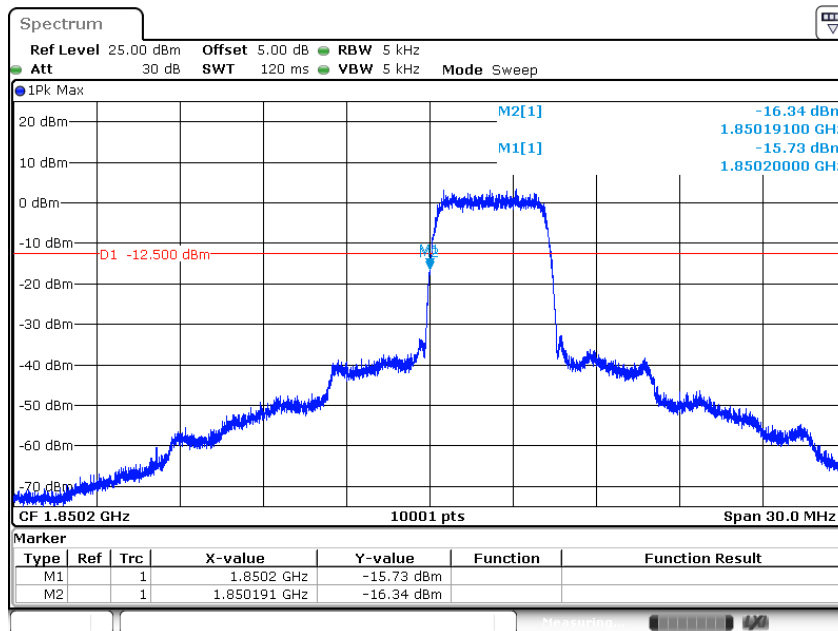

Date: 25 MAY 2017 16:00:42

Figure Channel 9538 (1907.60MHz)

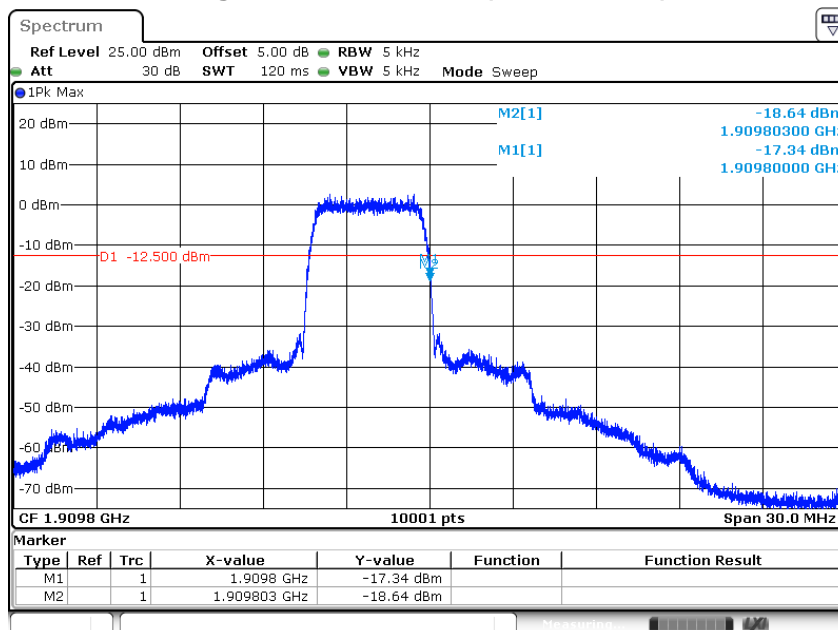

Date: 25 MAY 2017 16:02:09

Product	3G Cellular Alarm Communicator		
Test Item	Spurious Emission At Antenna Terminals (+/- 1MHz)		
Test Mode	Mode 9: WCDMA Band 2_HSUPA_Link		
Date of Test	2017/05/25	Test Site	SR10-H

Figure Channel 9262 (1852.40MHz)

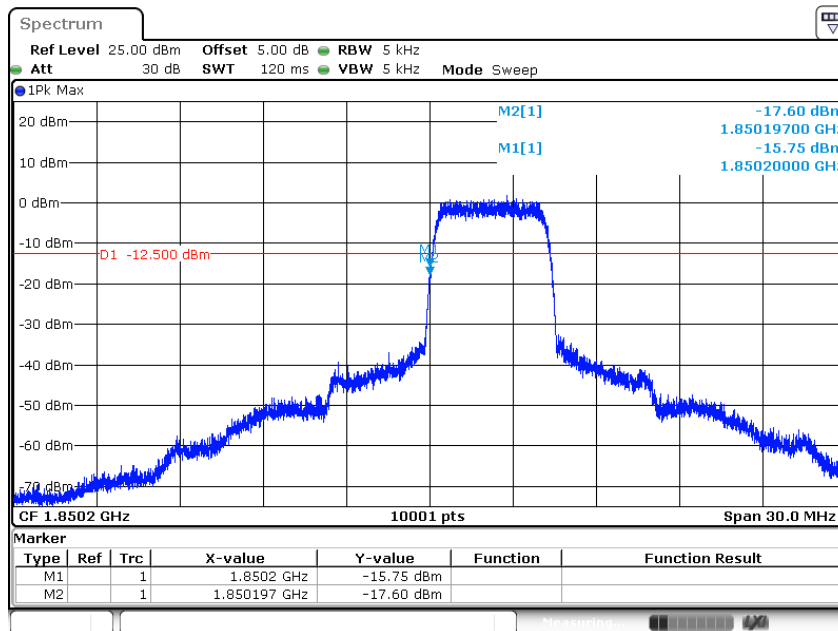

Date: 25 MAY 2017 15:44:38

Figure Channel 9538 (1907.60MHz)

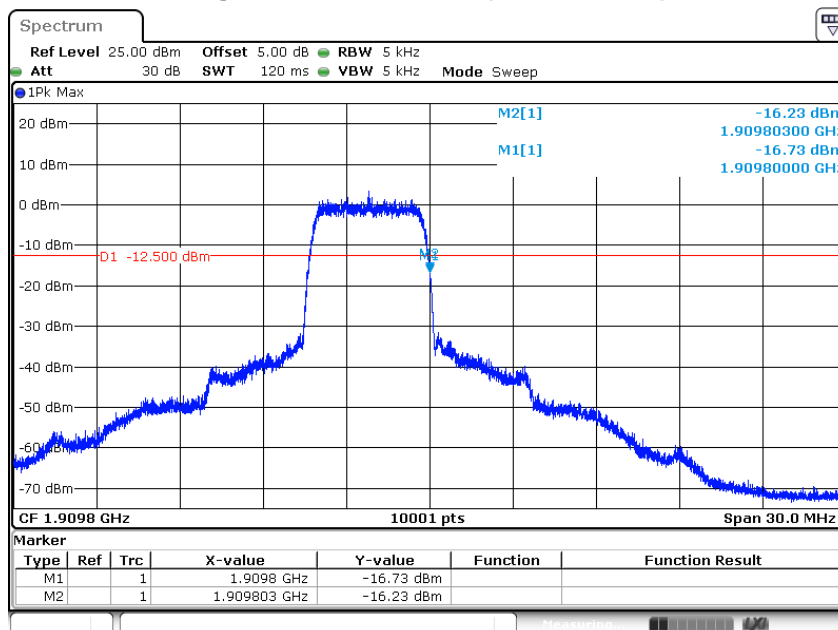

Date: 25 MAY 2017 15:56:45

Product	3G Cellular Alarm Communicator		
Test Item	Spurious Emission At Antenna Terminals (+/- 1MHz)		
Test Mode	Mode 10: WCDMA Band 2_HSDPA_Link		
Date of Test	2017/05/25	Test Site	SR10-H

Figure Channel 9262 (1852.40MHz)

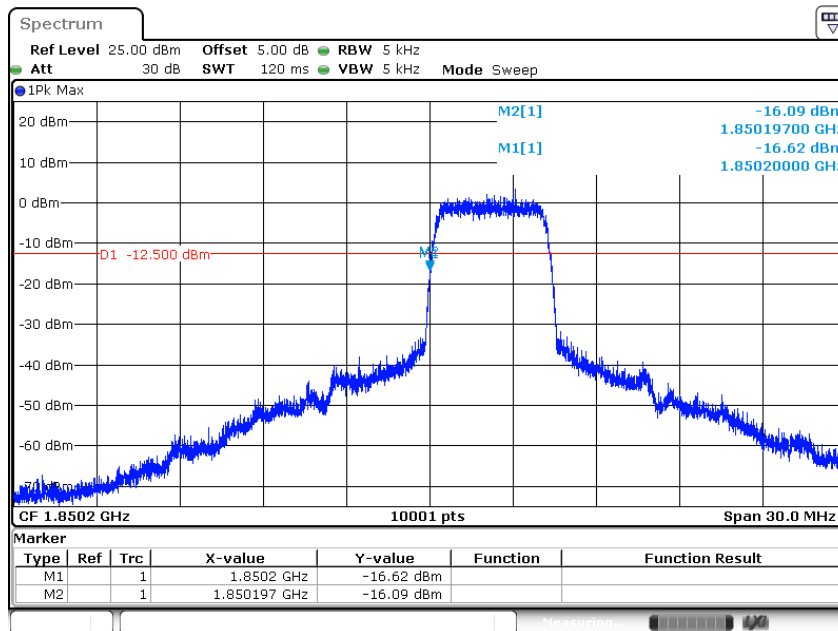

Date: 25 MAY 2017 15:59:28

Figure Channel 9538 (1907.60MHz)

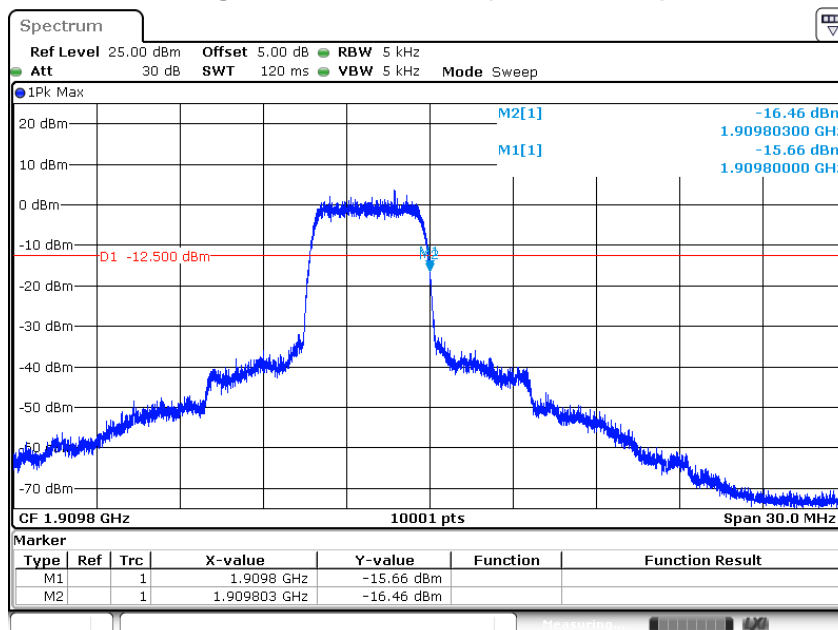

Date: 25 MAY 2017 15:58:24

## 6. Spurious Emission

### 6.1. Test Equipment

Conducted Emission / SR10-H

Instrument	Manufacturer	Type No.	Serial No	Cali. Due Date
Signal & Spectrum Analyzer	R&S	FSVA40	101455	2017/11/27
Multisystem UE Tester	Japan radio	NJZ-2000	ET00477	2017/09/19
Directional coupler	Agilent	778D	20402	2017/10/06

Radiated Spurious Emission / CB4-H

Instrument	Manufacturer	Type No.	Serial No	Cali. Due Date
Test Receiver	R&S	ESCS 30	836858/022	2018/01/14
Multisystem UE Tester	Japan radio	NJZ-2000	ET00477	2017/09/19
Signal & Spectrum Analyzer	R&S	FSVA40	101455	2017/11/27
Pre-Amplifier	DEKRA	AP-025C	CHM-0706049	2017/12/18
Bilog Antenna	Schaffner	CBL6112B	2797	2017/08/14
Pre-Amplifier	EMCI	EMC0031835	980233	2018/02/02
Horn Antenna	Schwarzbeck	BBHA 9120	D639	2017/06/29

### 6.2. Test Setup

Conducted Spurious Measurement: below 1GHz

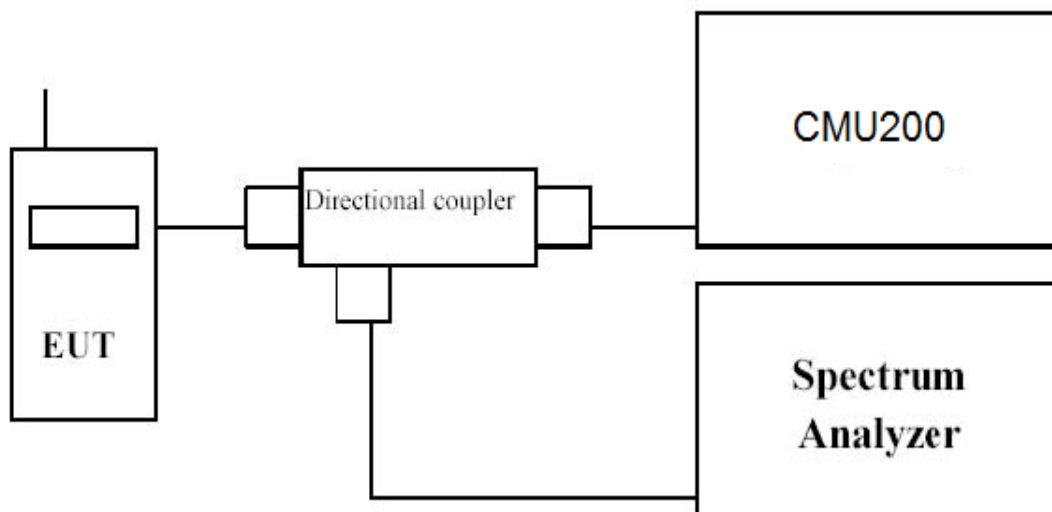

Radiated Spurious Measurement: below 1GHz

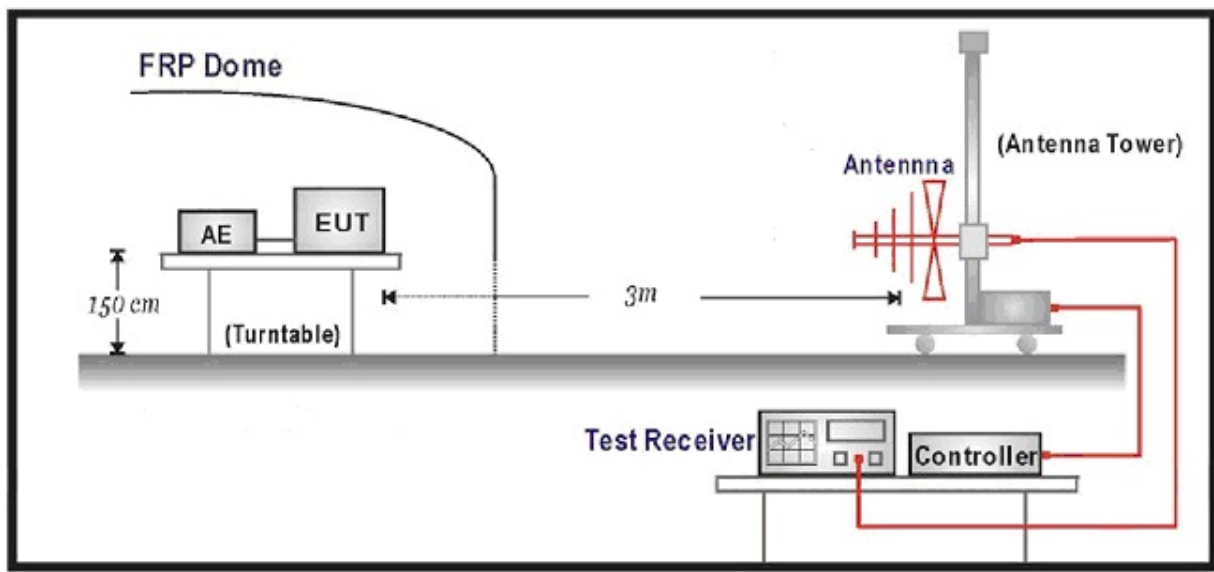

Radiated Spurious Measurement: above 1GHz

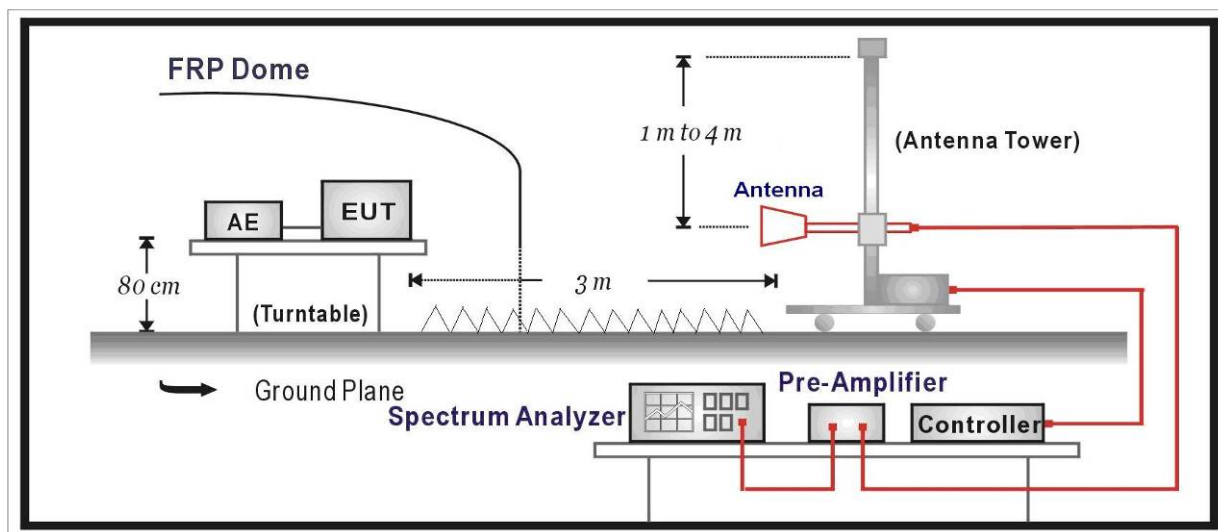

### 6.3. Test Procedure

#### Conducted Spurious Measurement:

- a) Place the EUT on a bench and set it in transmitting mode.
- b) Connect a low loss RF cable from the antenna port to a spectrum analyzer and CMU200 by a Directional Couple.
- c) EUT Communicate with CMU200, then select a channel for testing.
- d) Add a correction factor to the display of spectrum, and then test.
- e) The resolution bandwidth of the spectrum analyzer was set at 1 MHz, sufficient scans were taken to show the out of band Emission if any up to 10<sup>th</sup> harmonic.

#### Radiated Spurious Measurement:

- f) The EUT was placed on a rotatable wooden table with 1.5 meter above ground.
- g) The EUT was set 3 meters from the receiving antenna, which was mounted on the antenna tower.
- h) The table was rotated 360 degrees to determine the position of the highest spurious emission.
- i) The height of the receiving antenna is varied between one meter and four meters to search the maximum spurious emission for both horizontal and vertical polarizations.
- j) Make the measurement with the spectrum analyzer's RBW = 1MHz, VBW = 1MHz, Sweep 500ms, Taking the record of maximum spurious emission.
- k) A horn antenna was substituted in place of the EUT and was driven by a signal generator.
- l) Tune the output power of signal generator to the same emission level with EUT maximum spurious emission.
- m) Taking the record of output power at antenna port
- n) Repeat step 7 to step 8 for another polarization.
- o)  $EIRP = SG - \text{Cable loss} + \text{Antenna Gain}$

### 6.4. Uncertainty

The measurement uncertainty is defined as 3.2 dB for Radiated Power Measurement.

### 6.5. Test Result

Product	3G Cellular Alarm Communicator		
Test Item	Conducted Spurious Emission		
Test Mode	Mode 1: GPRS 850_Link		
Date of Test	2017/05/27	Test Site	SR10-H

#### Low Channel 128 (824.20MHz)

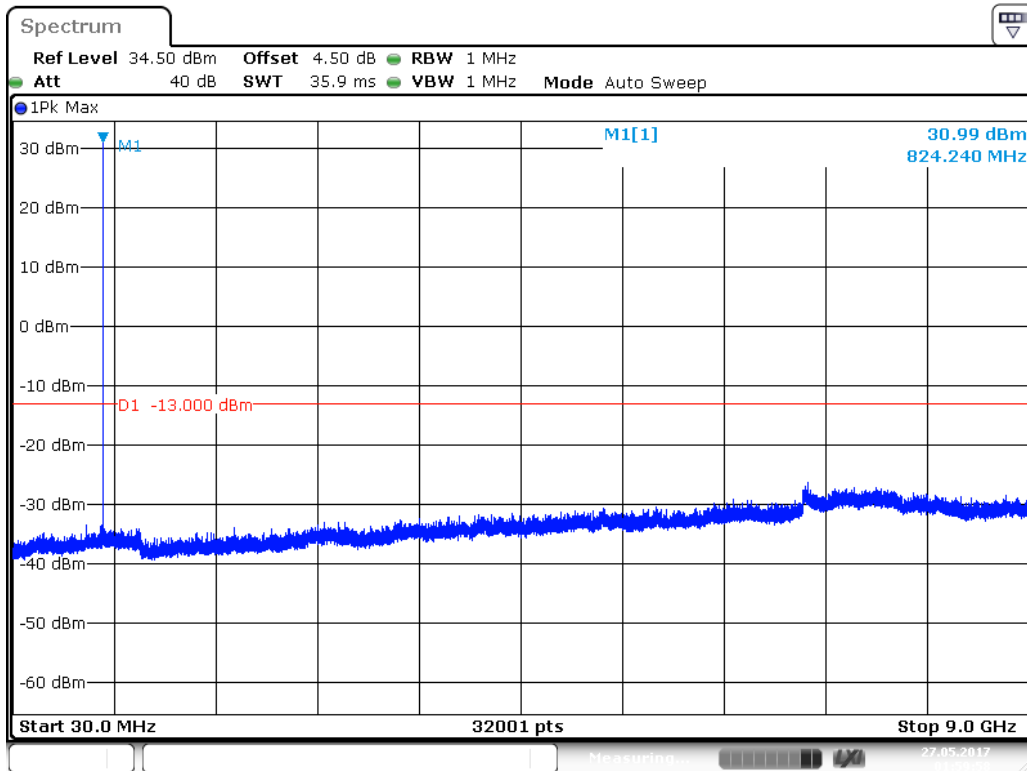

Date: 27 MAY 2017 01:59:59

### Mid Channel 190 (836.60MHz)

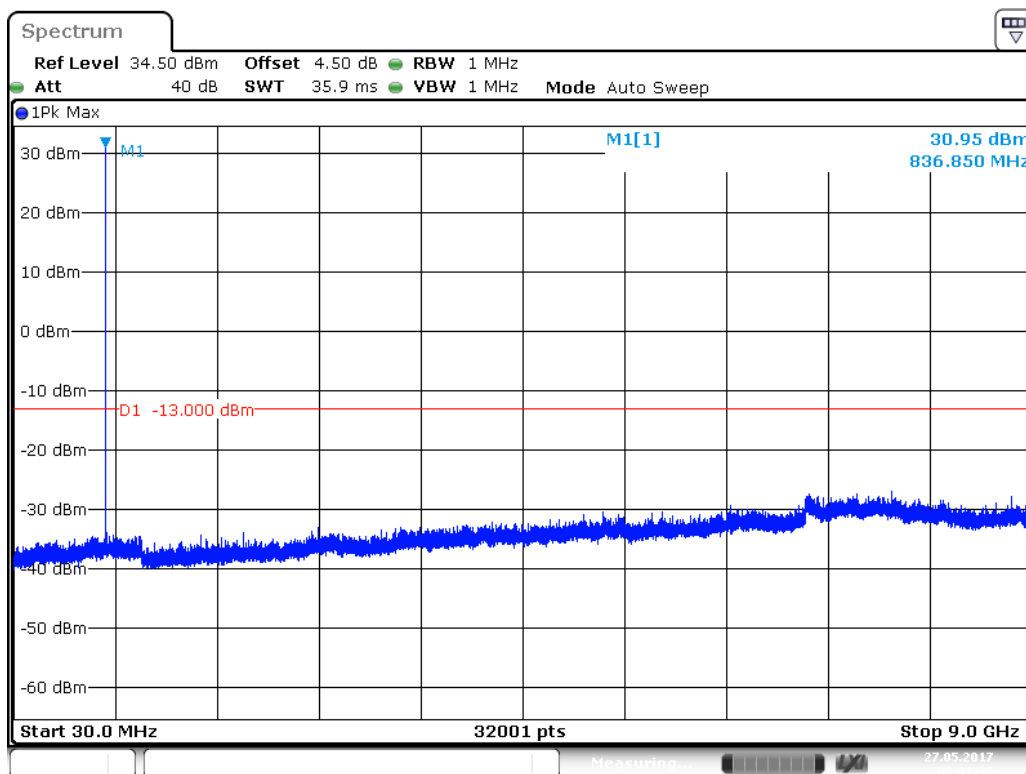

Date: 27 MAY 2017 02:01:39

### High Channel 251 (848.80MHz)

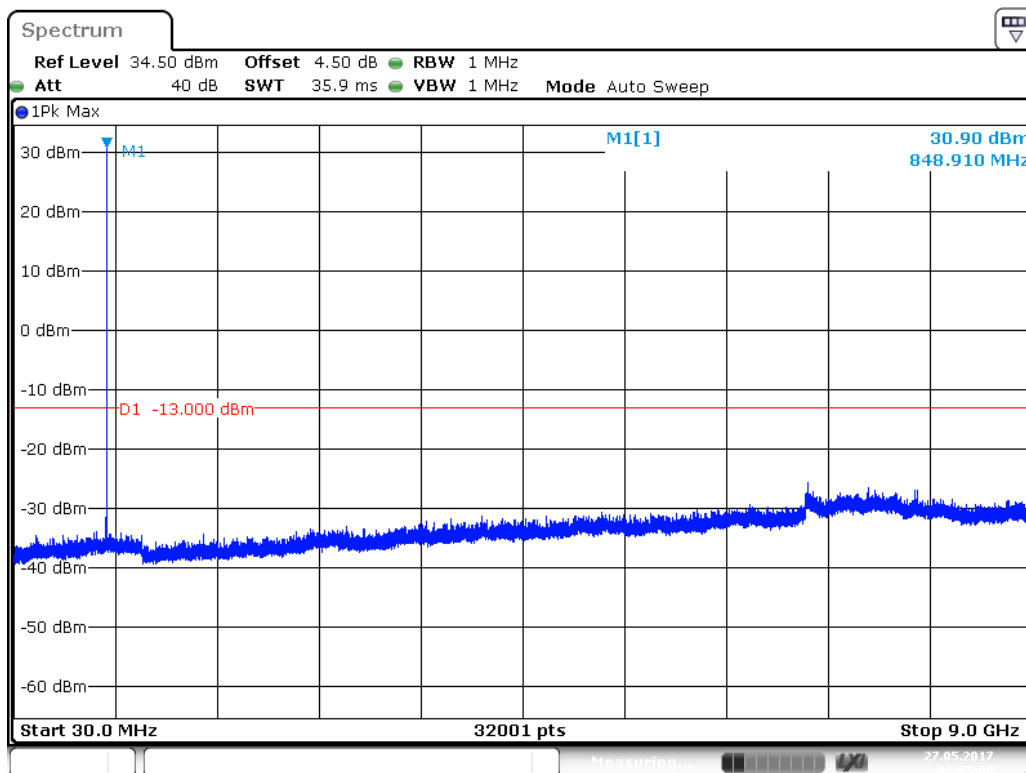

Date: 27 MAY 2017 02:05:00



Product	3G Cellular Alarm Communicator		
Test Item	Conducted Spurious Emission		
Test Mode	Mode 2: GPRS 1900_Link		
Date of Test	2017/05/27	Test Site	SR10-H

### Low Channel 512 (1850.20MHz)

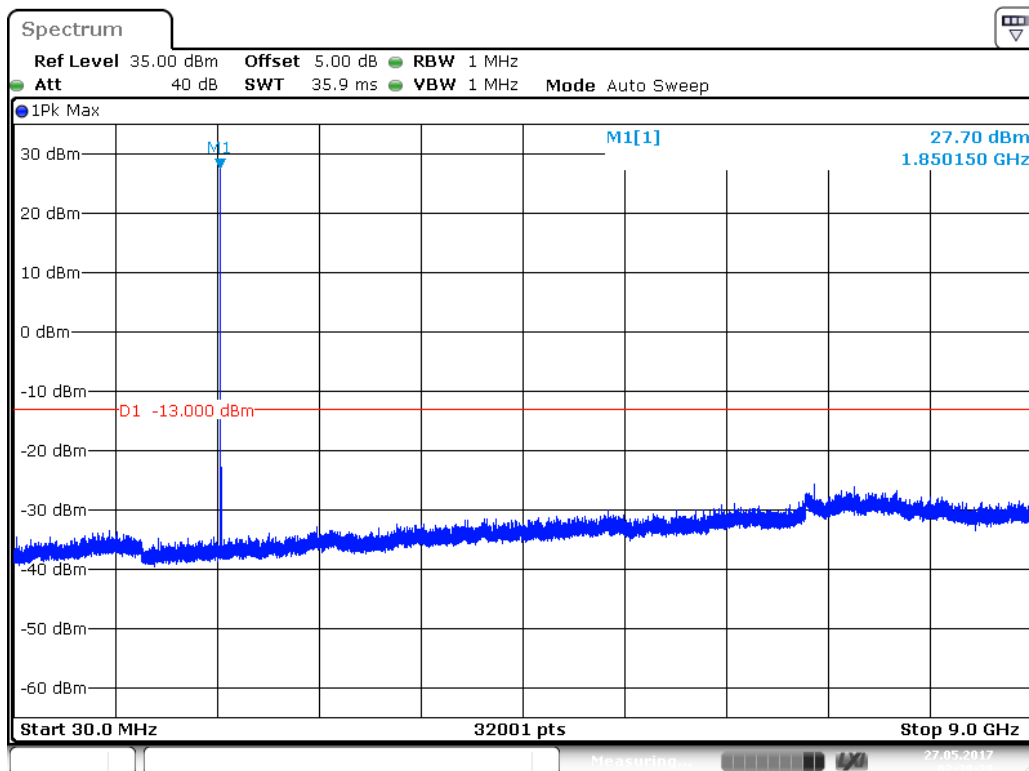

Date: 27 MAY 2017 02:38:29

### Mid Channel 661 (1880.00MHz)

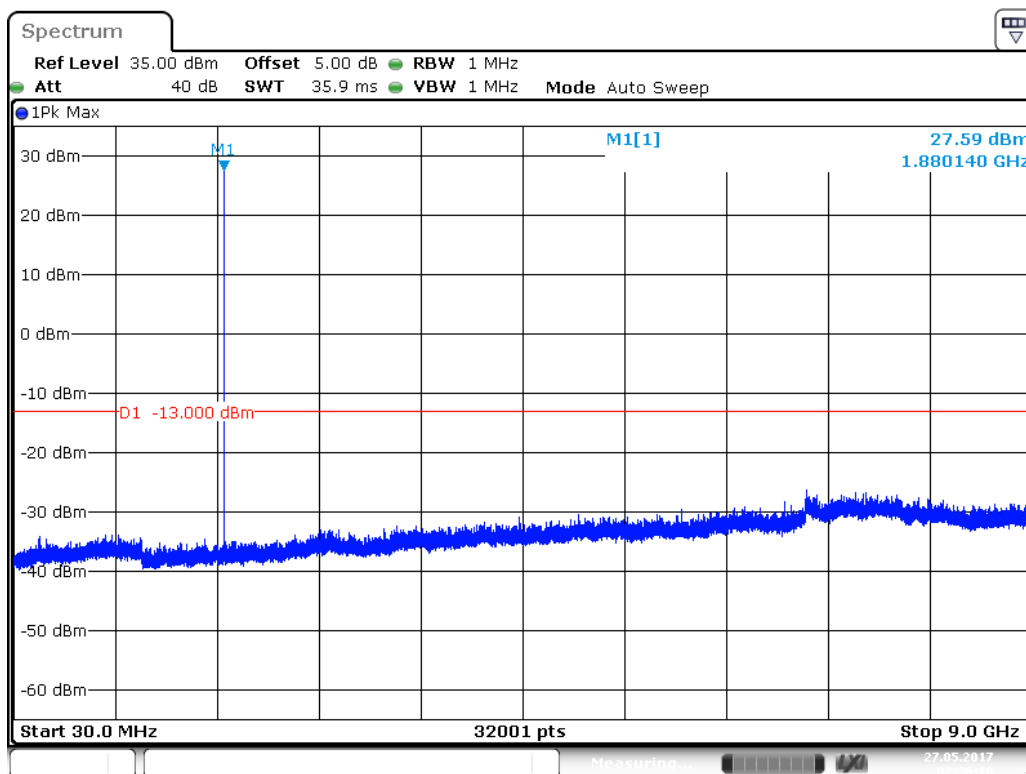

Date: 27 MAY 2017 02:36:18

### High Channel 810 (1909.80MHz)

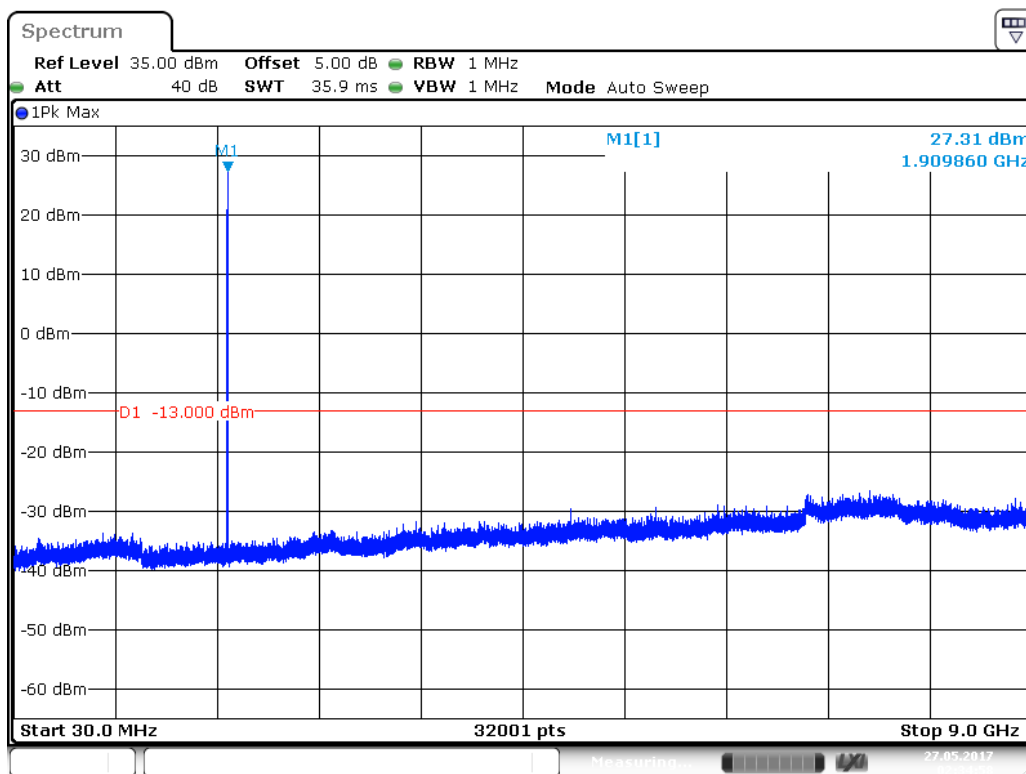

Date: 27 MAY 2017 02:34:58

Product	3G Cellular Alarm Communicator		
Test Item	Conducted Spurious Emission		
Test Mode	Mode 3: EGPRS 850_Link		
Date of Test	2017/05/27	Test Site	SR10-H

### Low Channel 128 (824.20MHz)

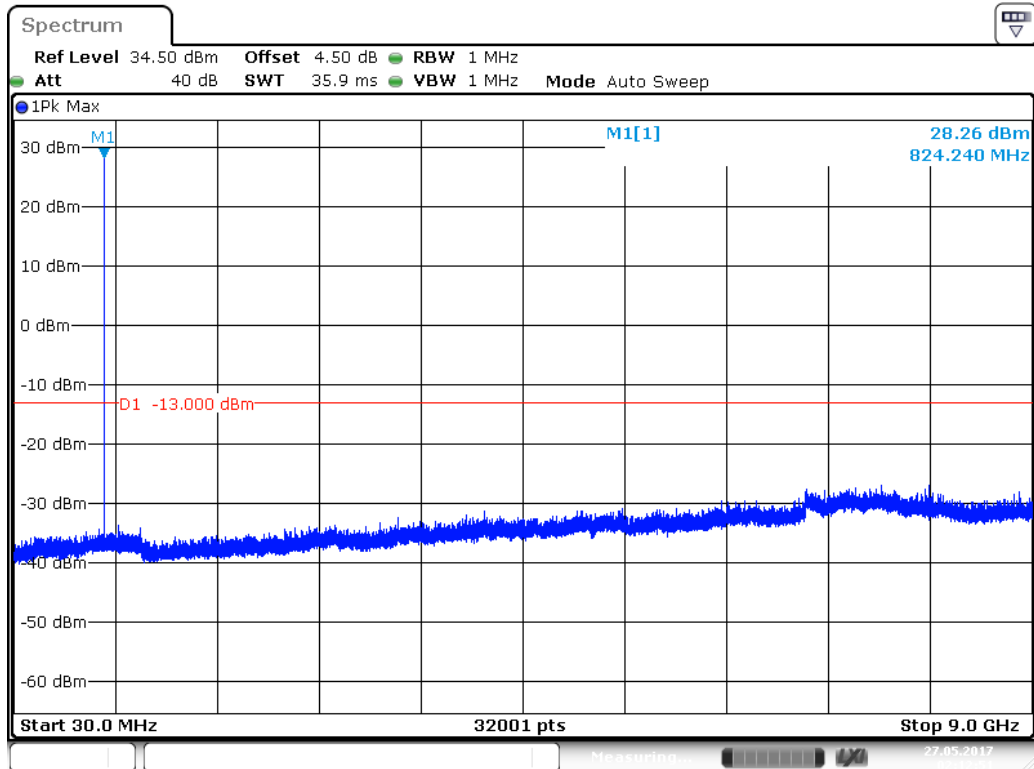

Date: 27 MAY 2017 02:12:51

### Mid Channel 190 (836.60MHz)

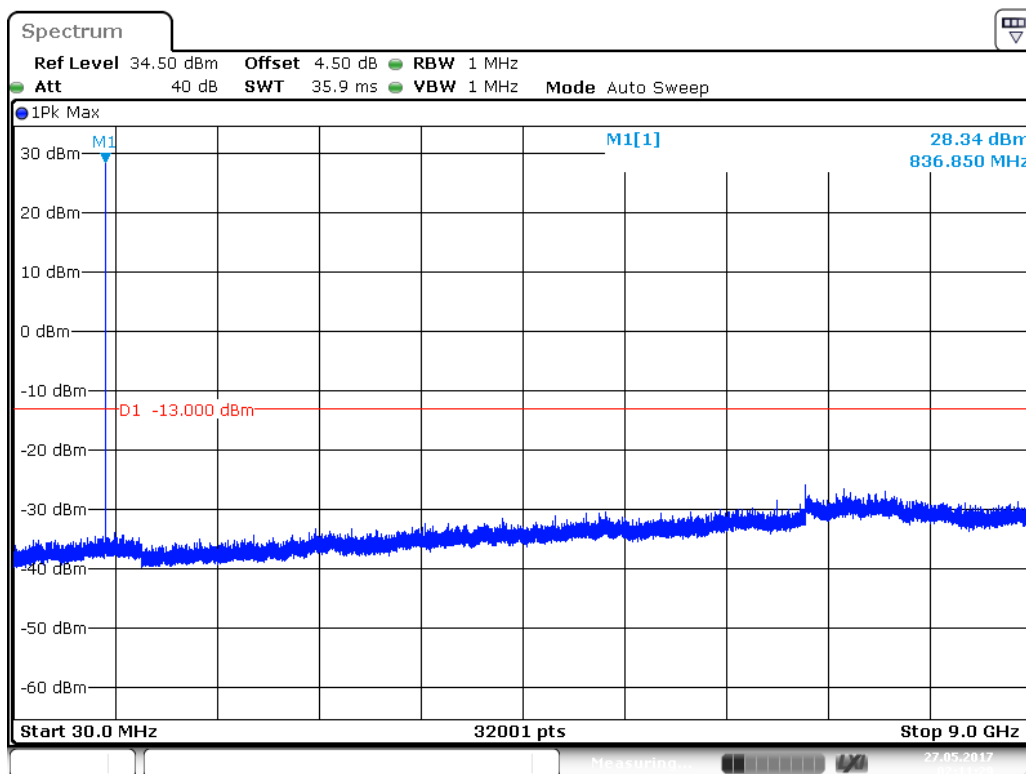

Date: 27 MAY 2017 02:11:29

### High Channel 251 (848.80MHz)

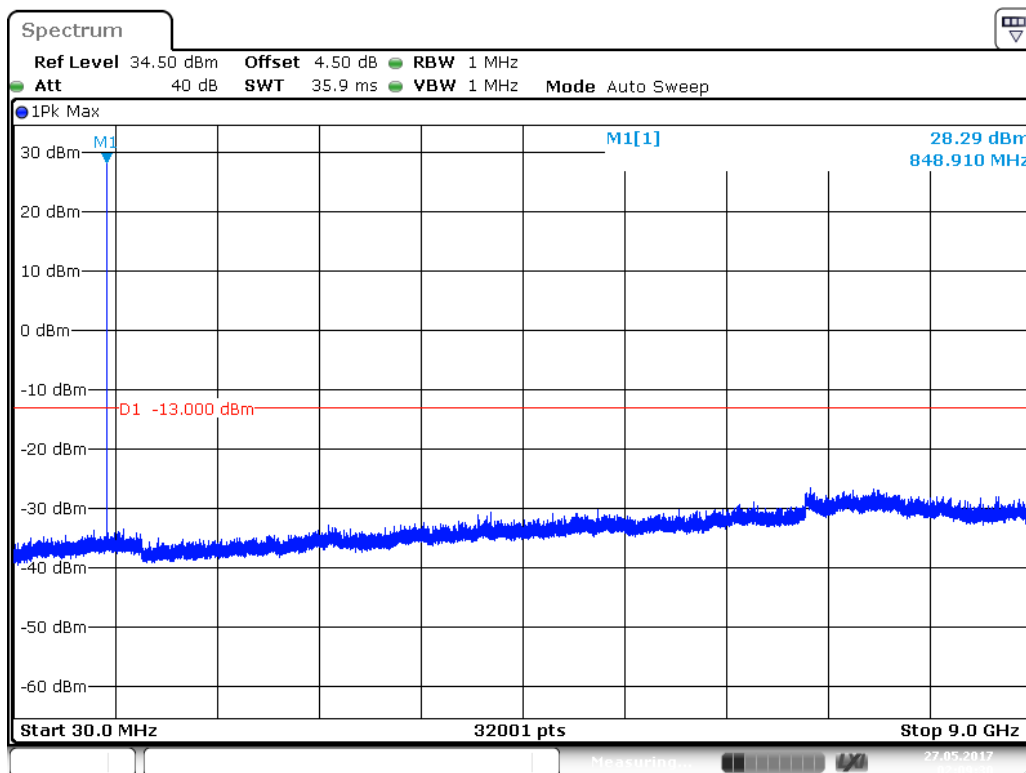

Date: 27 MAY 2017 02:09:31

Product	3G Cellular Alarm Communicator		
Test Item	Conducted Spurious Emission		
Test Mode	Mode 4: EGPRS 1900_Link		
Date of Test	2017/05/27	Test Site	SR10-H

### Low Channel 512 (1850.20MHz)

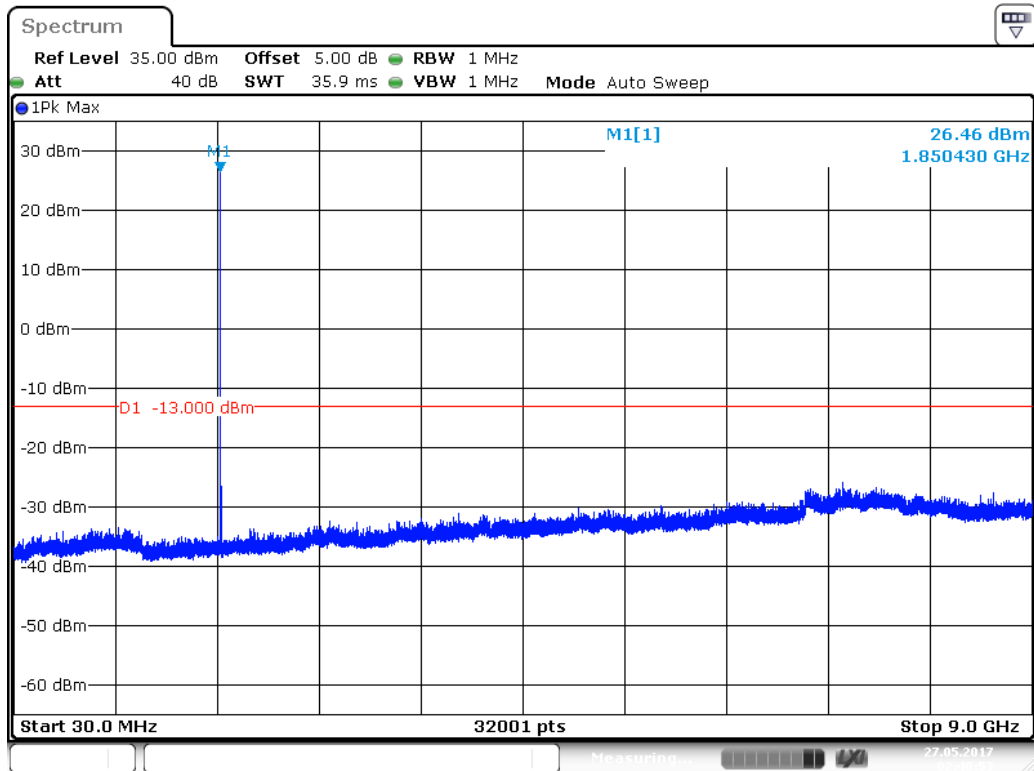

Date: 27.MAY.2017 02:40:53

### Mid Channel 661 (1880.00MHz)

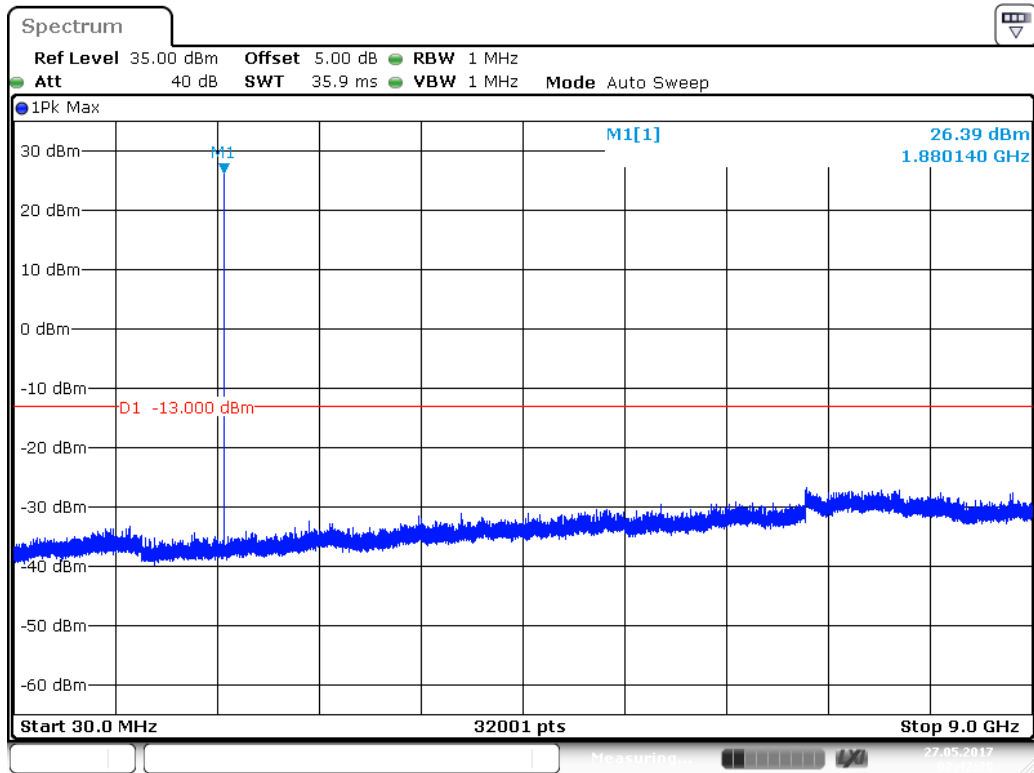

### High Channel 810 (1909.80MHz)

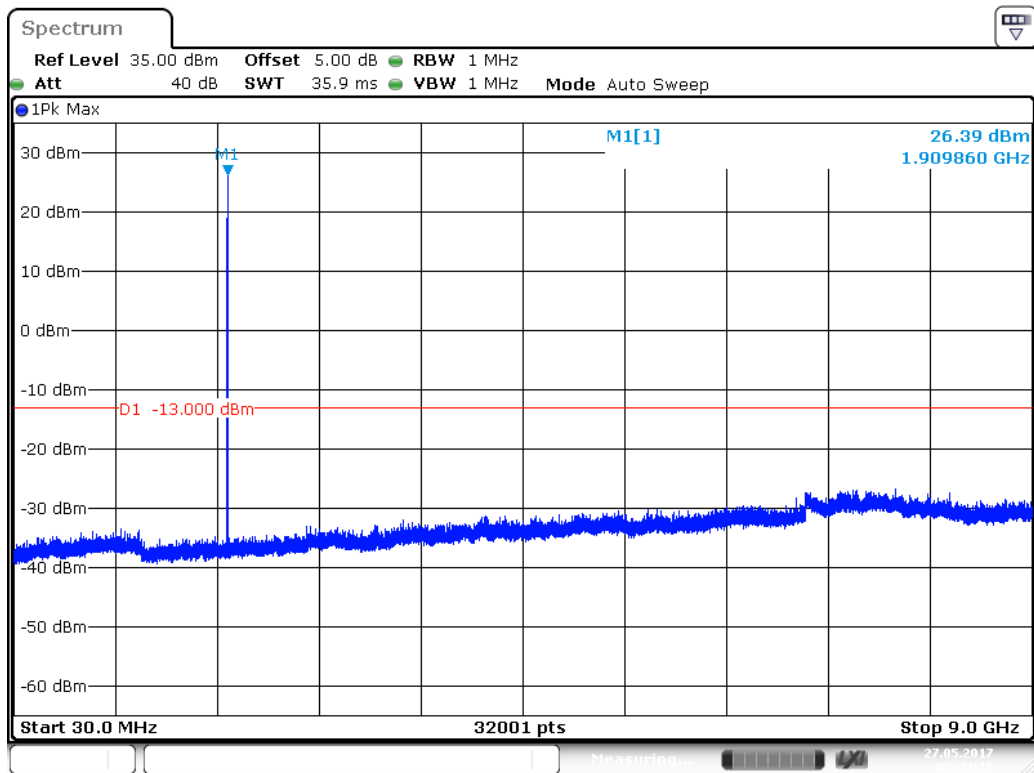

Product	3G Cellular Alarm Communicator		
Test Item	Conducted Spurious Emission		
Test Mode	Mode 5: WCDMA Band 5_Link		
Date of Test	2017/05/27	Test Site	SR10-H

### Low Channel 4132 (826.40MHz)

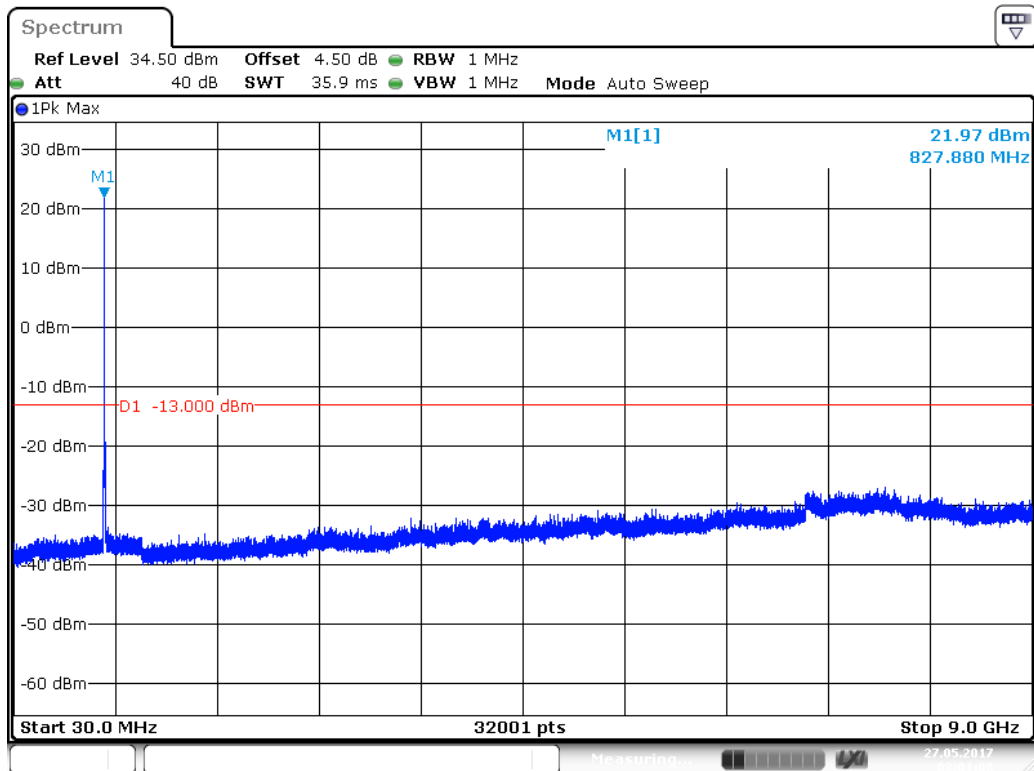

Date: 27 MAY 2017 03:01:08

### Mid Channel 4182(836.60MHz)

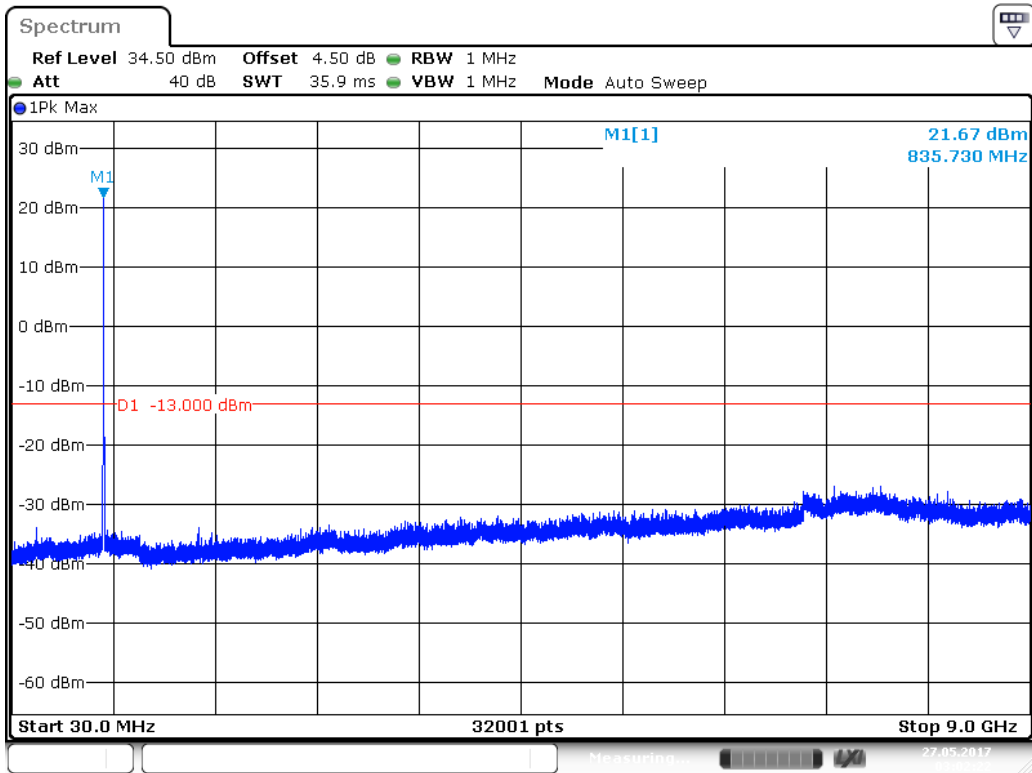

Date: 27 MAY 2017 03:02:22

### High Channel 4233(846.60MHz)

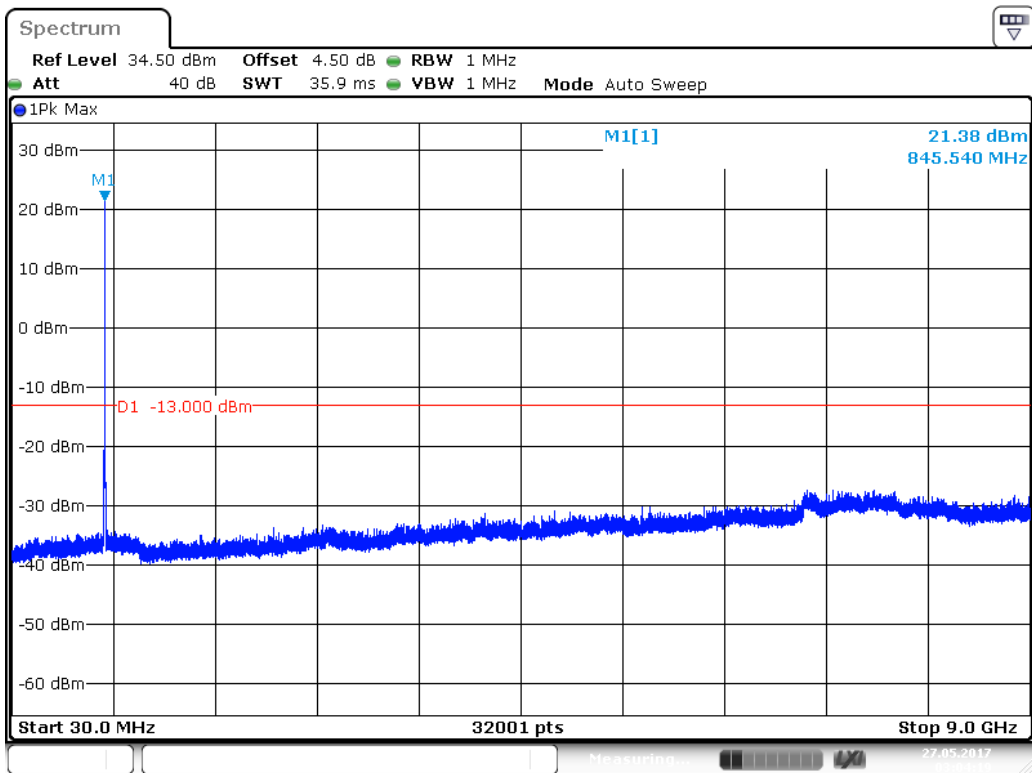

Date: 27 MAY 2017 03:04:19



Product	3G Cellular Alarm Communicator		
Test Item	Conducted Spurious Emission		
Test Mode	Mode 6: WCDMA Band 5_HSUPA_Link		
Date of Test	2017/05/27	Test Site	SR10-H

### Low Channel 4132 (826.40MHz)

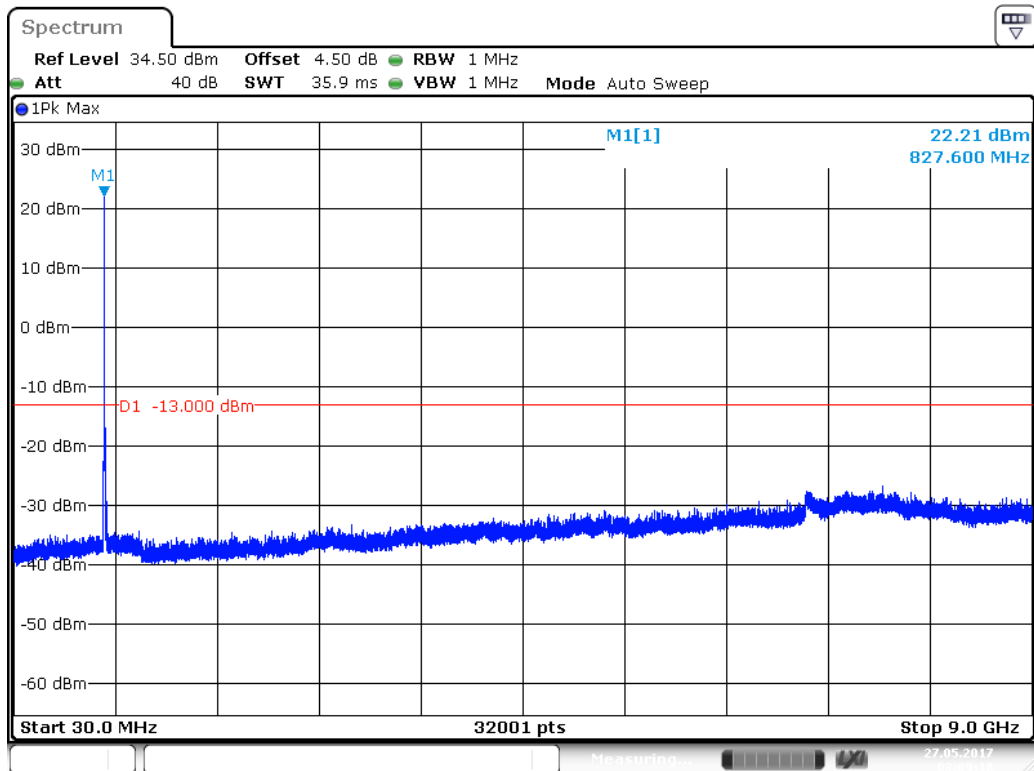

Date: 27 MAY 2017 03:09:18

### Mid Channel 4182 (836.60MHz)

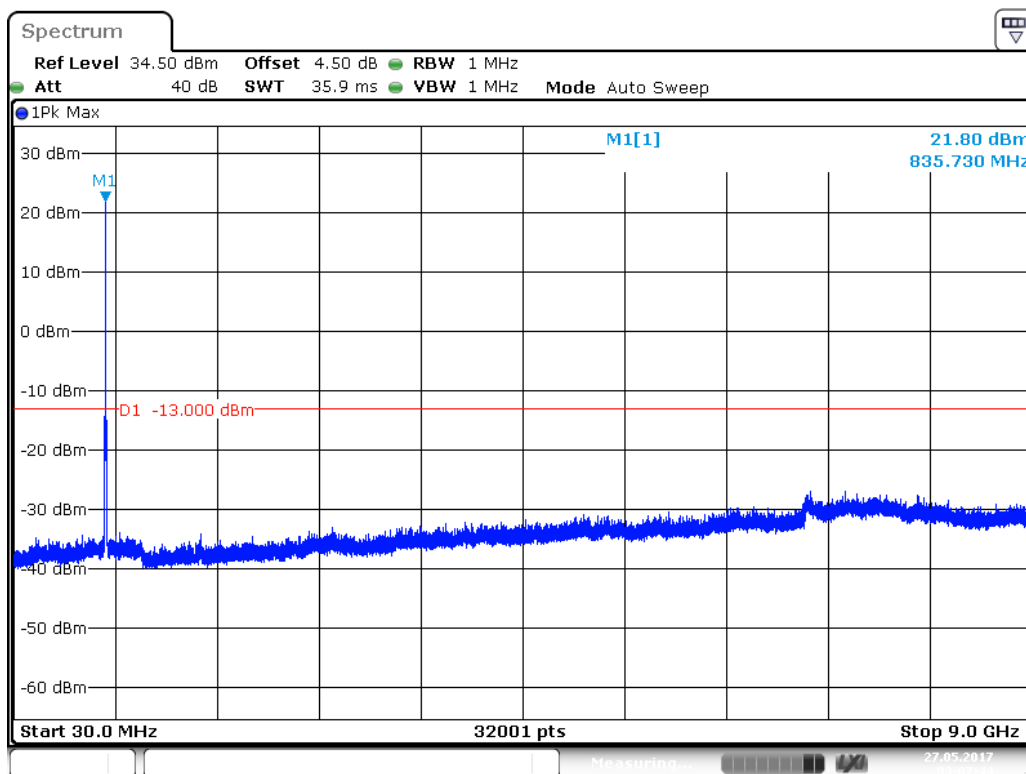

Date: 27 MAY 2017 03:07:44

### High Channel 4233 (846.60MHz)

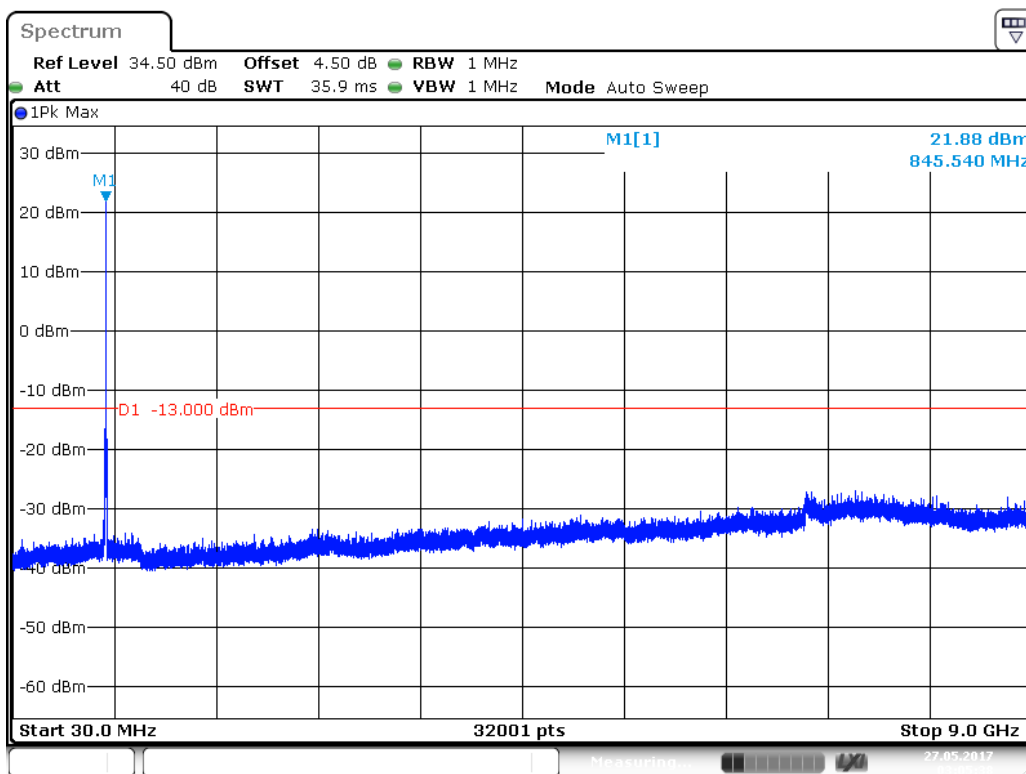

Date: 27 MAY 2017 03:05:38

Product	3G Cellular Alarm Communicator		
Test Item	Conducted Spurious Emission		
Test Mode	Mode 7: WCDMA Band 5_HSDPA_Link		
Date of Test	2017/05/27	Test Site	SR10-H

### Low Channel 4132 (826.40MHz)

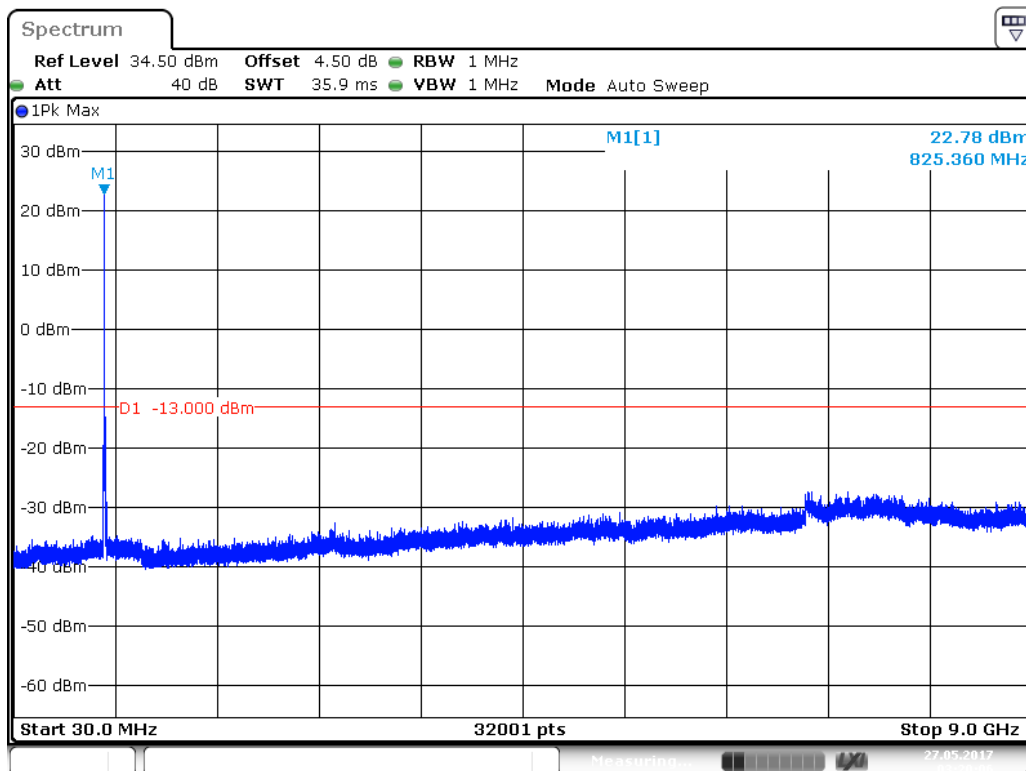

Date: 27 MAY 2017 03:20:06

### Mid Channel 4182 (836.60MHz)

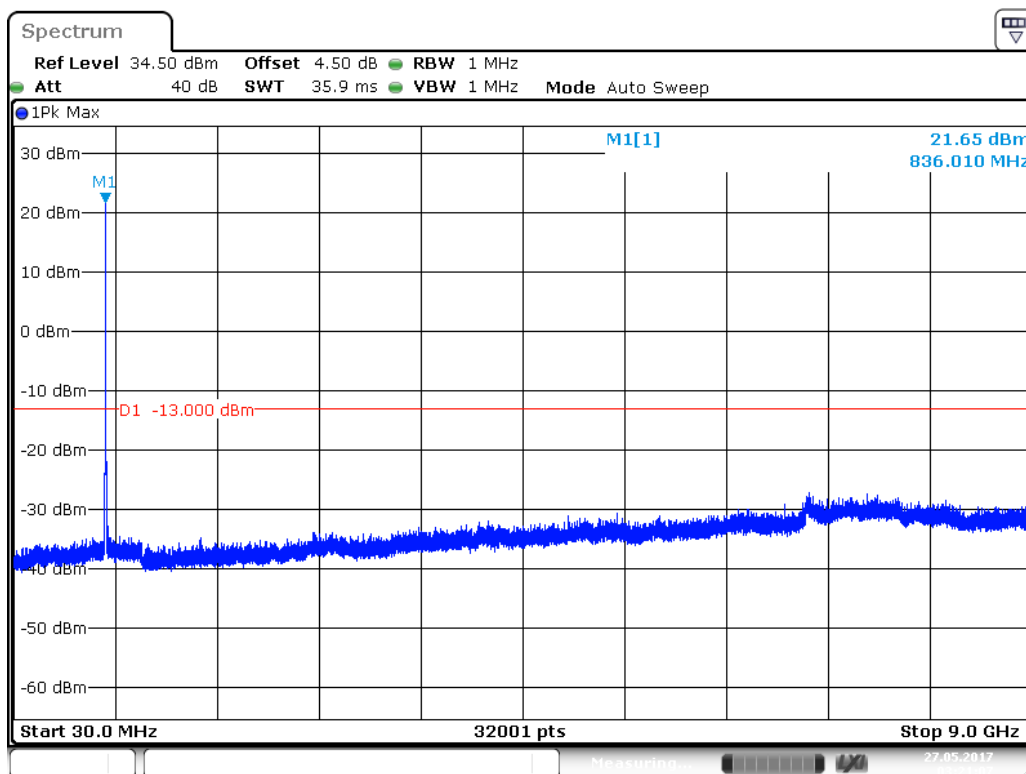

Date: 27 MAY 2017 03:21:06

### High Channel 4233 (846.60MHz)

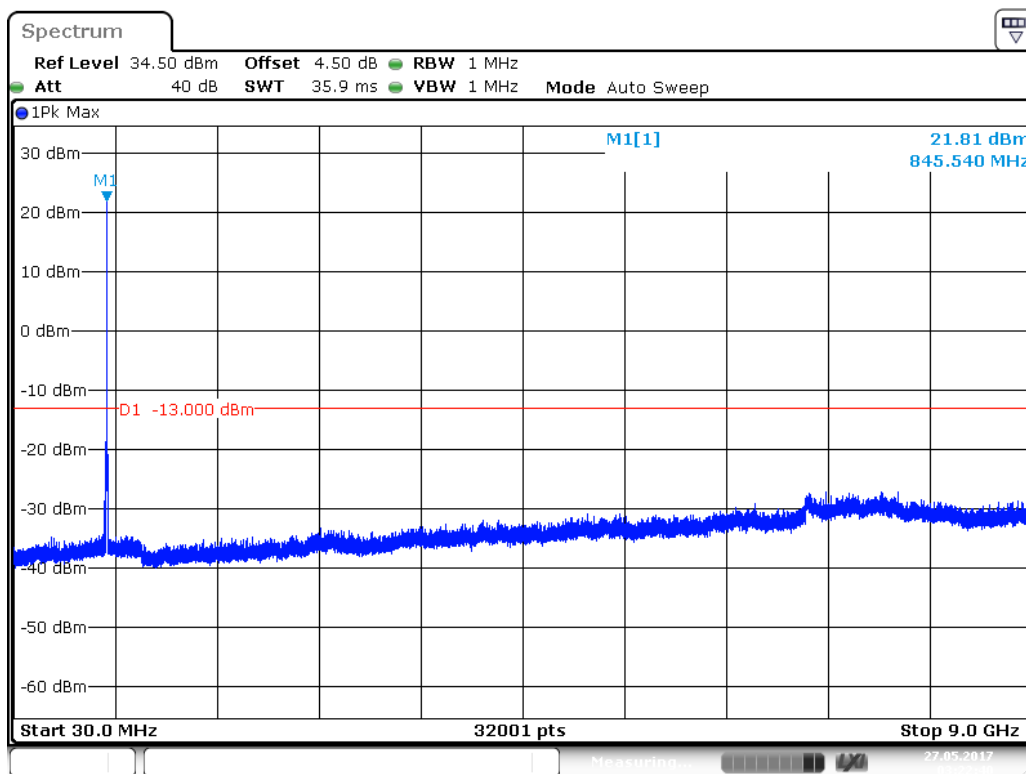

Date: 27 MAY 2017 03:22:40

Product	3G Cellular Alarm Communicator		
Test Item	Conducted Spurious Emission		
Test Mode	Mode 8: WCDMA Band 2_Link		
Date of Test	2017/05/27	Test Site	SR10-H

### Low Channel 9262 (1852.40MHz)

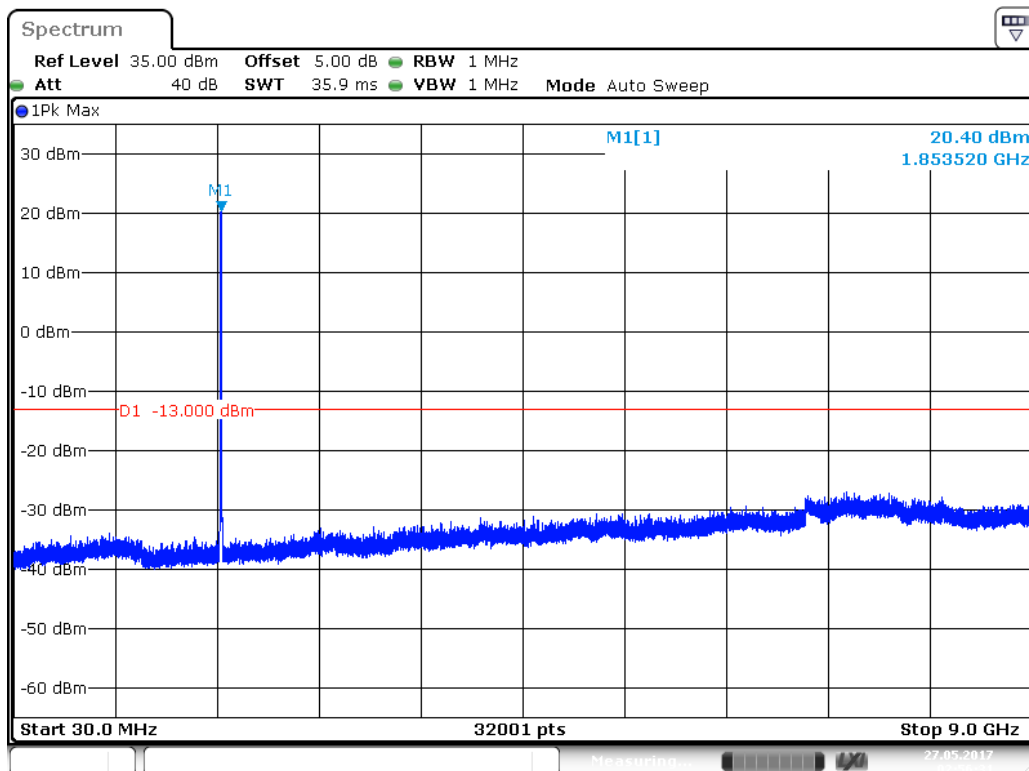

Date: 27 MAY 2017 02:56:31

### Mid Channel 9400 (1880.00MHz)

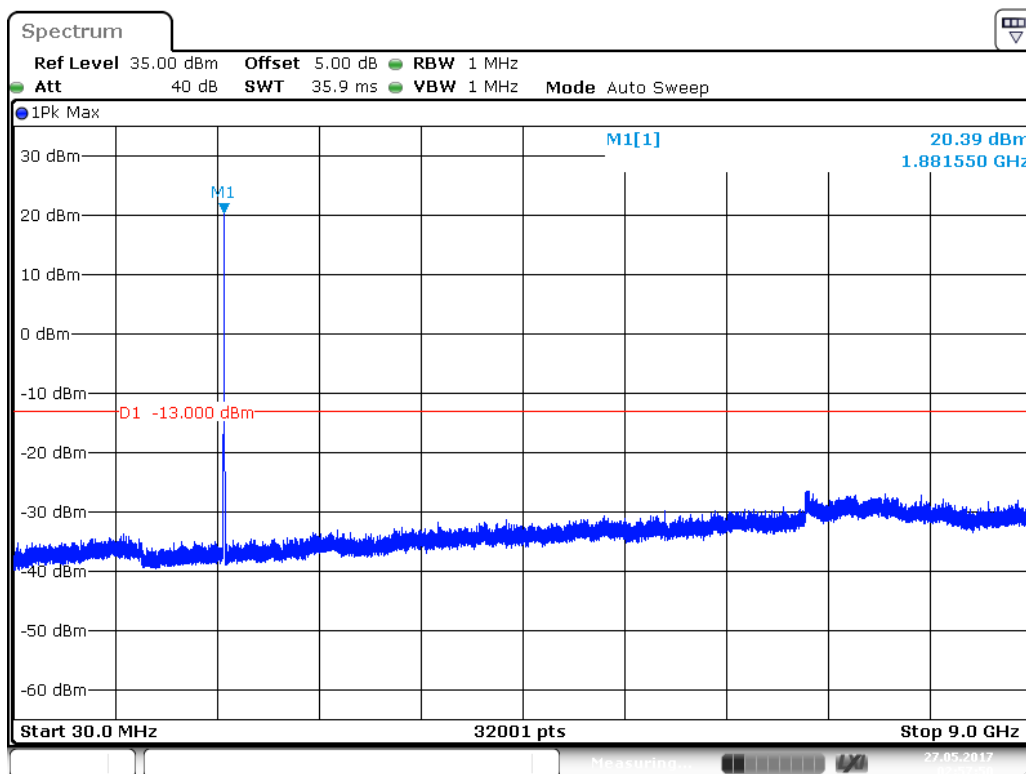

### High Channel 9538 (1907.60MHz)

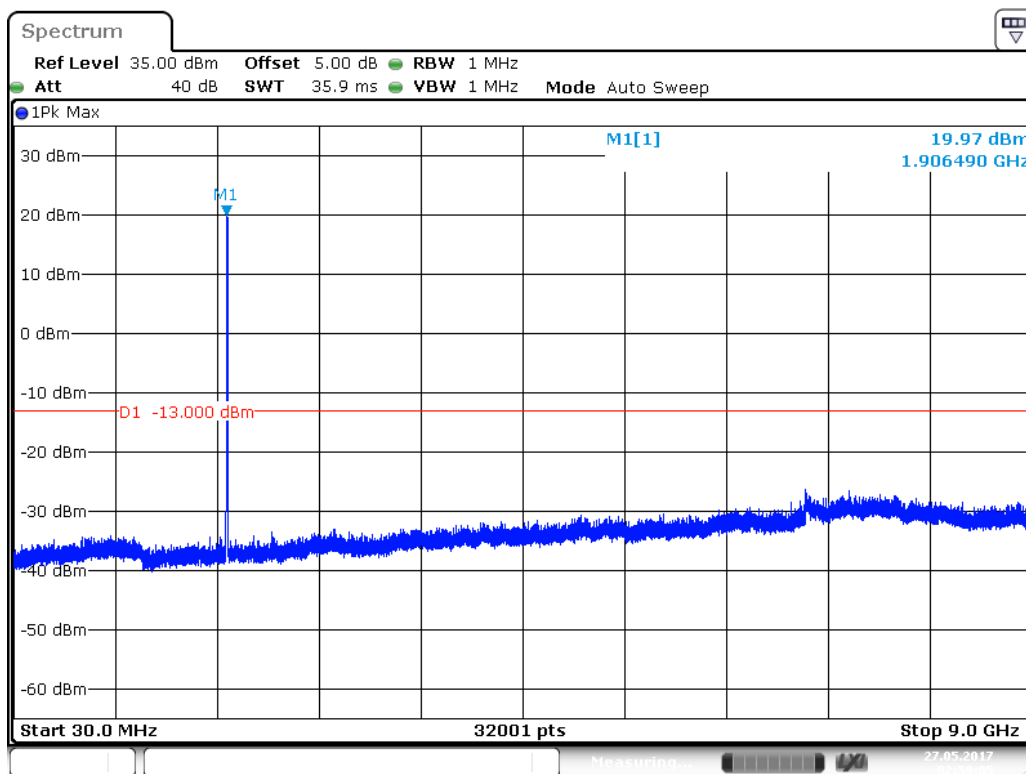

Product	3G Cellular Alarm Communicator		
Test Item	Conducted Spurious Emission		
Test Mode	Mode 9: WCDMA Band 2_HSUPA_Link		
Date of Test	2017/05/27	Test Site	SR10-H

### Low Channel 9262 (1852.40MHz)

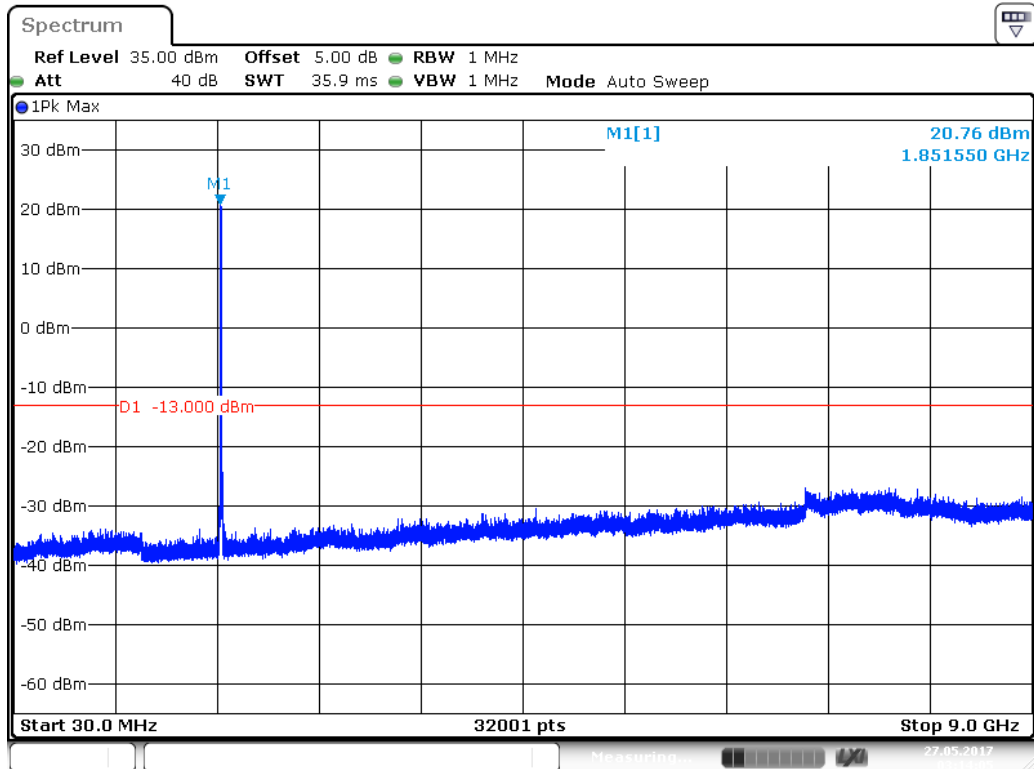

Date: 27 MAY 2017 03:14:05

### Mid Channel 9400 (1880.00MHz)

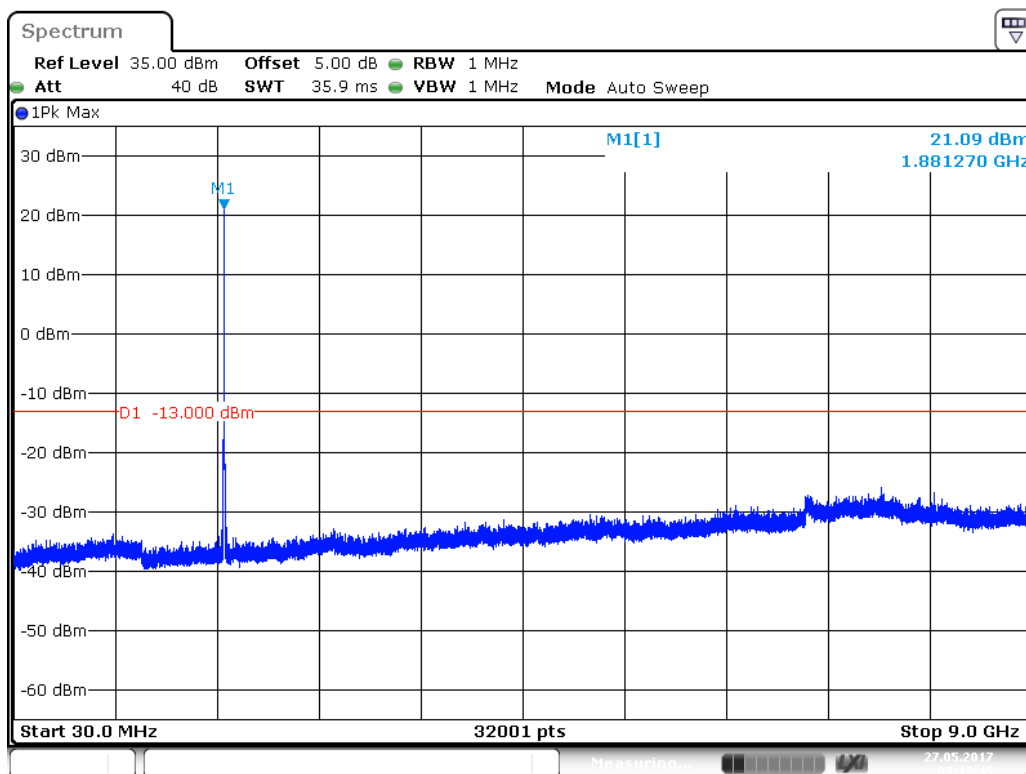

Date: 27 MAY 2017 03:12:45

### High Channel 9538 (1907.60MHz)

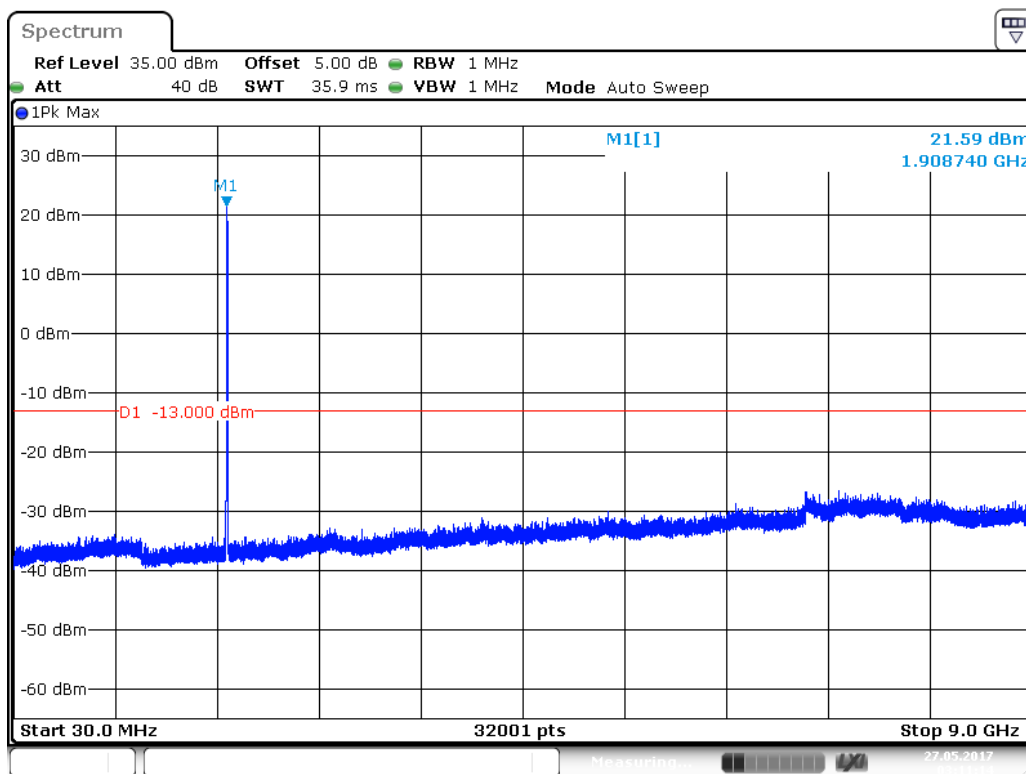

Date: 27 MAY 2017 03:11:14



Product	3G Cellular Alarm Communicator		
Test Item	Conducted Spurious Emission		
Test Mode	Mode 10: WCDMA Band 2_HSDPA_Link		
Date of Test	2017/05/27	Test Site	SR10-H

### Low Channel 9262 (1852.40MHz)

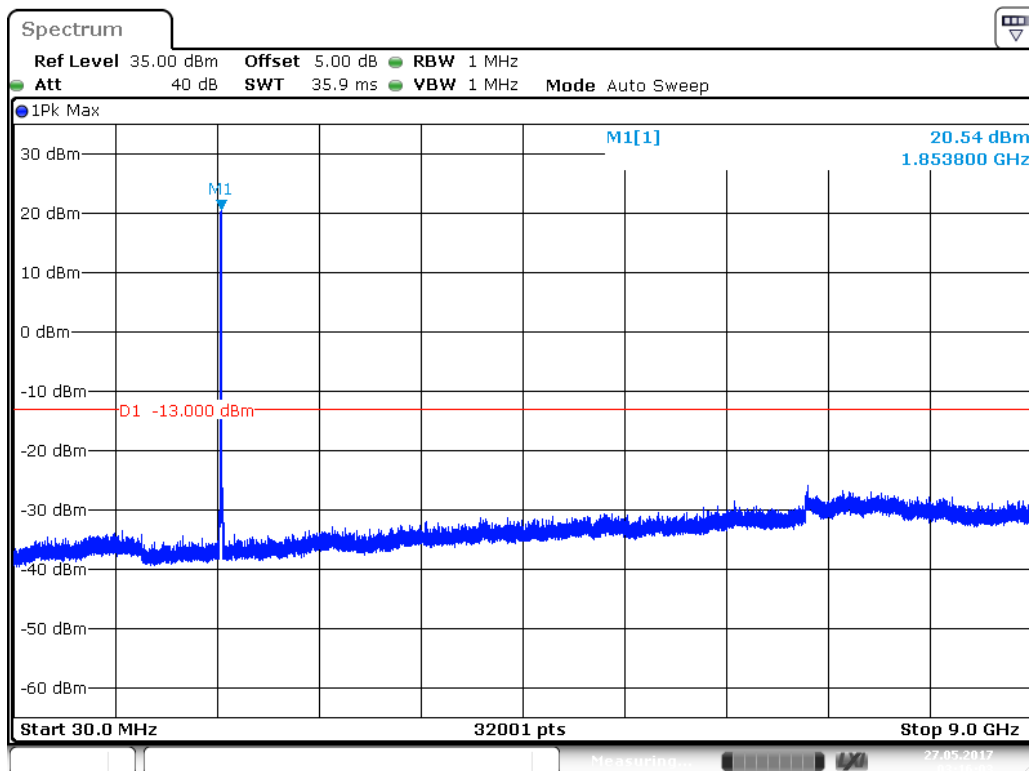

Date: 27 MAY 2017 03:16:02

### Mid Channel 9400 (1880.00MHz)

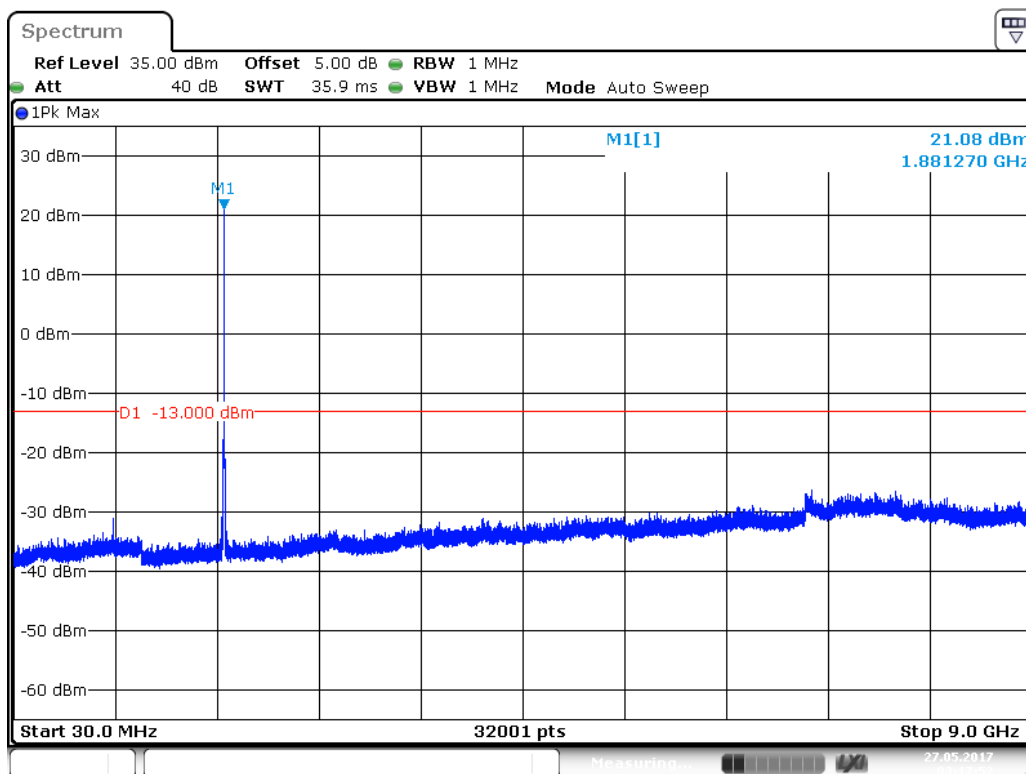

Date: 27 MAY 2017 03:17:53

### High Channel 9538 (1907.60MHz)

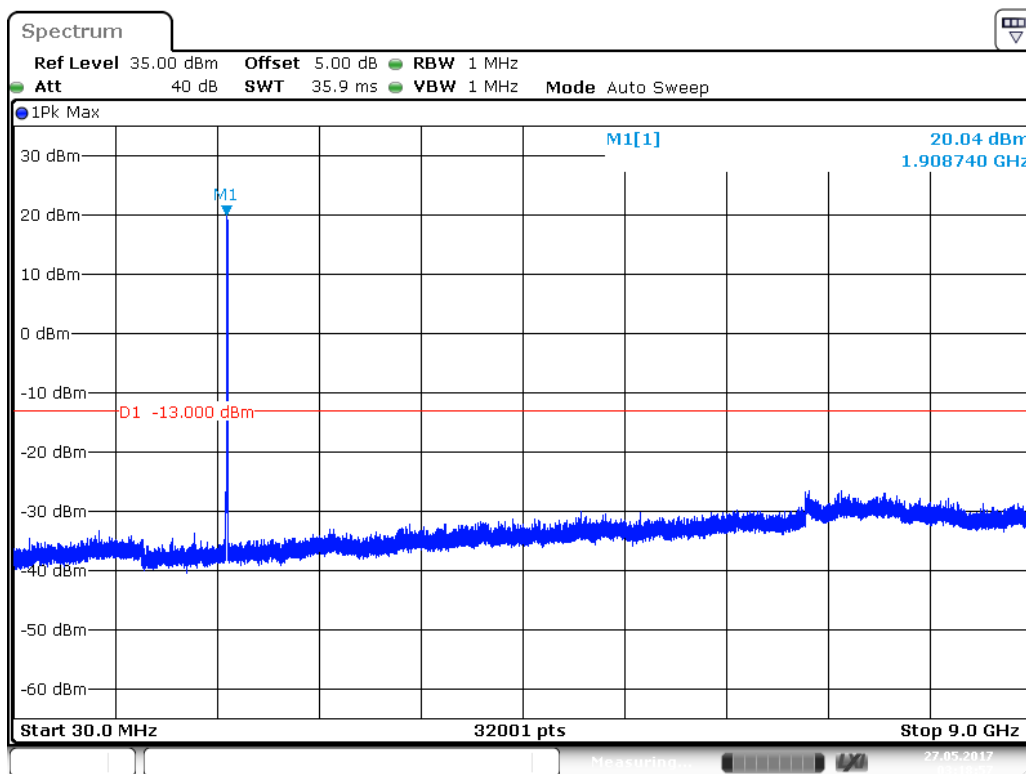

Date: 27 MAY 2017 03:18:57

### Harmonic & Spurious:

Site : CB4-H	Time : 2017/05/26
Limit : FCC_Part22/24_00M_00M_PK	Margin : 6
Probe : CB4-H_CE_Sub_B432_1-18GHz_3M_1116 - HORIZONTAL	Power : DC 24V
EUT : 3G Cellular Alarm Communicator	Note : Mode 1: GPRS 850_Link_824.2MHz

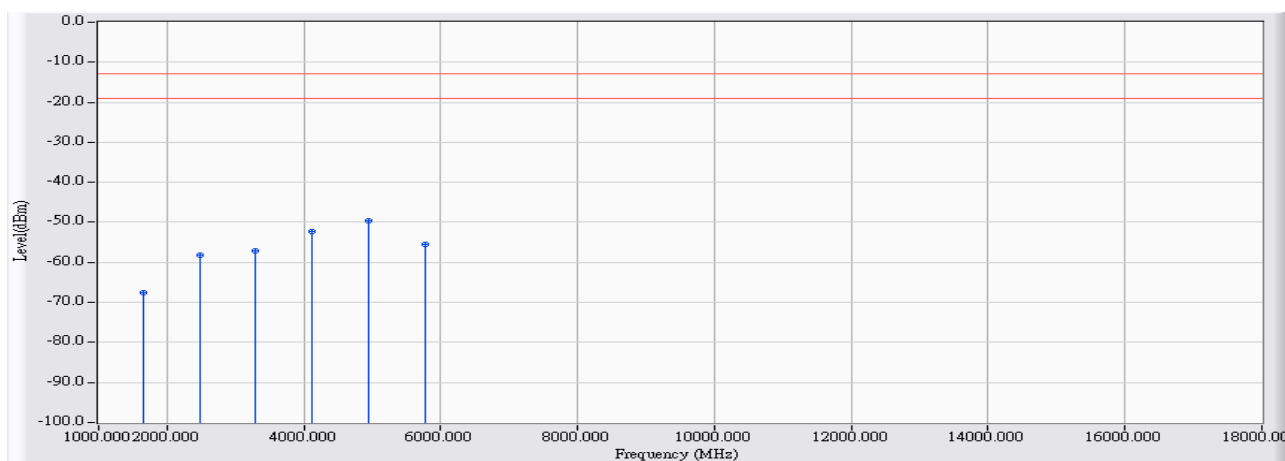

	Frequency (MHz)	Correct Factor (dB)	Reading Level (dBm)	Measure Level (dBm)	Margin (dB)	Limit (dBm)	Detector Type
1	1648.400	2.526	-70.180	-67.655	-54.655	-13.000	PEAK
2	2472.600	7.434	-65.560	-58.127	-45.127	-13.000	PEAK
3	3296.800	10.254	-67.490	-57.237	-44.237	-13.000	PEAK
4	4121.000	12.098	-64.460	-52.362	-39.362	-13.000	PEAK
5	* 4945.200	15.801	-65.470	-49.669	-36.669	-13.000	PEAK
6	5769.400	15.316	-70.680	-55.363	-42.363	-13.000	PEAK

Note:

1. All readings above 1GHz are performed with peak and/or average measurements as necessary.
2. Peak measurements: RBW = 1MHz, VBW = 1MHz, Sweep: Auto.
3. Average measurements: RBW = 1MHz, VBW = 10 Hz, Sweep: Auto.
4. “ \* ”, means this data is the worst emission level.
5. Measurement Level = Reading Level + Correct Factor.
6. The average measurement was not performed when the peak measured data under the limit of average detection.
7. The Emission above 18GHz were not included is because their levels are too low.

Site : CB4-H	Time : 2017/05/26
Limit : FCC_Part22/24_00M_00M_PK	Margin : 6
Probe : CB4-H_CE_Sub_B432_1-18GHz_3M_1116 - VERTICAL	Power : DC 24V
EUT : 3G Cellular Alarm Communicator	Note : Mode 1: GPRS 850_Link_824.2MHz

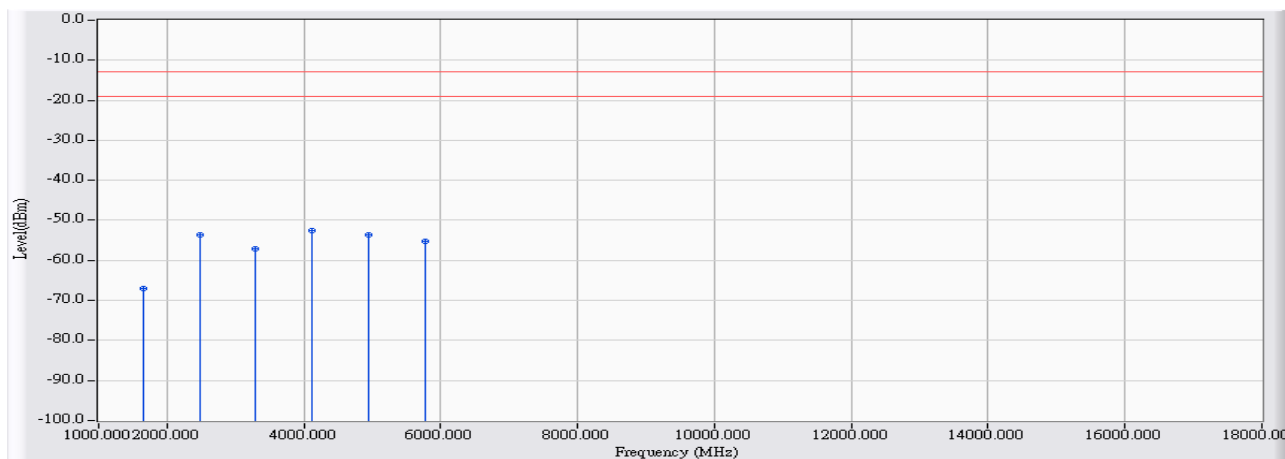

	Frequency (MHz)	Correct Factor (dB)	Reading Level (dBm)	Measure Level (dBm)	Margin (dB)	Limit (dBm)	Detector Type
1	1648.400	3.046	-70.040	-66.995	-53.995	-13.000	PEAK
2	2472.600	7.770	-61.260	-53.491	-40.491	-13.000	PEAK
3	3296.800	10.836	-67.920	-57.085	-44.085	-13.000	PEAK
4	* 4121.000	12.965	-65.420	-52.455	-39.455	-13.000	PEAK
5	4945.200	16.320	-69.820	-53.500	-40.500	-13.000	PEAK
6	5769.400	15.150	-70.380	-55.230	-42.230	-13.000	PEAK

Note:

1. All readings above 1GHz are performed with peak and/or average measurements as necessary.
2. Peak measurements: RBW = 1MHz, VBW = 1MHz, Sweep: Auto.
3. Average measurements: RBW = 1MHz, VBW = 10 Hz, Sweep: Auto.
4. “ \* ”, means this data is the worst emission level.
5. Measurement Level = Reading Level + Correct Factor.
6. The average measurement was not performed when the peak measured data under the limit of average detection.
7. The Emission above 18GHz were not included is because their levels are too low.

Site : CB4-H	Time : 2017/05/26
Limit : FCC_Part22/24_00M_00M_PK	Margin : 6
Probe : CB4-H_CE_Sub_B432_1-18GHz_3M_1116 - HORIZONTAL	Power : DC 24V
EUT : 3G Cellular Alarm Communicator	Note : Mode 1: GPRS 850_Link_836.6MHz

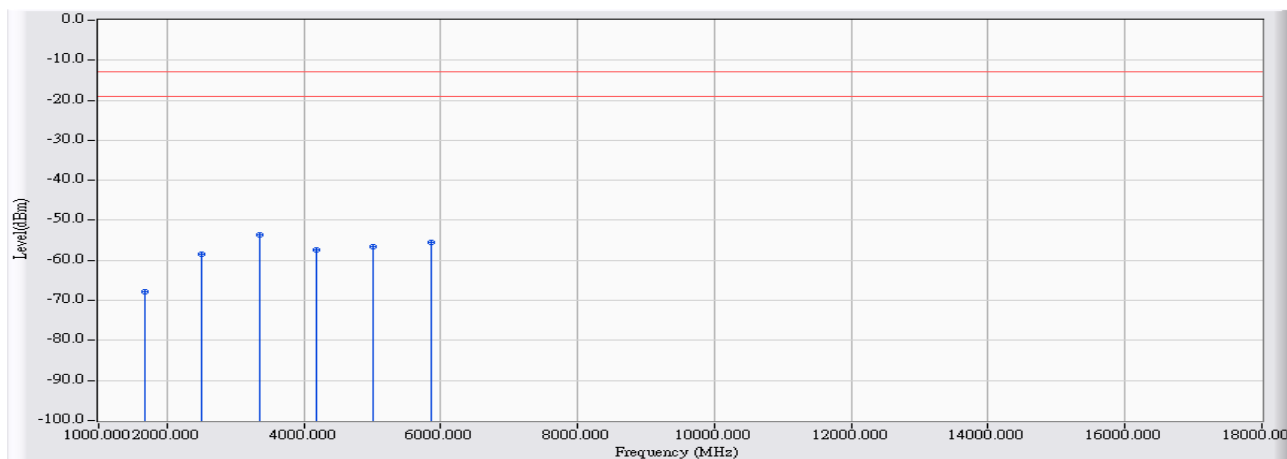

	Frequency (MHz)	Correct Factor (dB)	Reading Level (dBm)	Measure Level (dBm)	Margin (dB)	Limit (dBm)	Detector Type
1	1673.200	2.482	-70.350	-67.867	-54.867	-13.000	PEAK
2	2509.800	7.420	-65.750	-58.330	-45.330	-13.000	PEAK
3	* 3346.400	10.371	-64.120	-53.748	-40.748	-13.000	PEAK
4	4183.000	12.197	-69.680	-57.483	-44.483	-13.000	PEAK
5	5019.600	13.621	-70.180	-56.558	-43.558	-13.000	PEAK
6	5856.200	15.687	-71.260	-55.574	-42.574	-13.000	PEAK

Note:

1. All readings above 1GHz are performed with peak and/or average measurements as necessary.
2. Peak measurements: RBW = 1MHz, VBW = 1MHz, Sweep: Auto.
3. Average measurements: RBW = 1MHz, VBW = 10 Hz, Sweep: Auto.
4. “ \* ”, means this data is the worst emission level.
5. Measurement Level = Reading Level + Correct Factor.
6. The average measurement was not performed when the peak measured data under the limit of average detection.
7. The Emission above 18GHz were not included is because their levels are too low.

Site : CB4-H	Time : 2017/05/26
Limit : FCC_Part22/24_00M_00M_PK	Margin : 6
Probe : CB4-H_CE_Sub_B432_1-18GHz_3M_1116 - VERTICAL	Power : DC 24V
EUT : 3G Cellular Alarm Communicator	Note : Mode 1: GPRS 850_Link_836.6MHz

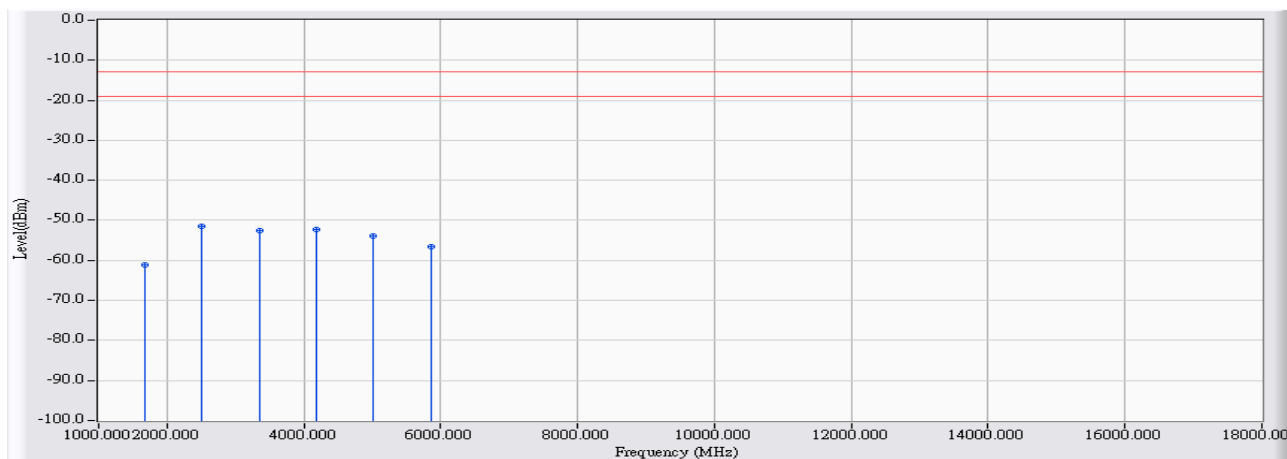

		Frequency (MHz)	Correct Factor (dB)	Reading Level (dBm)	Measure Level (dBm)	Margin (dB)	Limit (dBm)	Detector Type
1		1673.200	3.047	-64.150	-61.102	-48.102	-13.000	PEAK
2	*	2509.800	7.809	-59.330	-51.521	-38.521	-13.000	PEAK
3		3346.400	11.012	-63.630	-52.617	-39.617	-13.000	PEAK
4		4183.000	13.147	-65.540	-52.393	-39.393	-13.000	PEAK
5		5019.600	13.260	-67.100	-53.839	-40.839	-13.000	PEAK
6		5856.200	15.515	-72.120	-56.605	-43.605	-13.000	PEAK

**Note:**

1. All readings above 1GHz are performed with peak and/or average measurements as necessary.
2. Peak measurements: RBW = 1MHz, VBW = 1MHz, Sweep: Auto.
3. Average measurements: RBW = 1MHz, VBW = 10 Hz, Sweep: Auto.
4. “ \* ”, means this data is the worst emission level.
5. Measurement Level = Reading Level + Correct Factor.
6. The average measurement was not performed when the peak measured data under the limit of average detection.
7. The Emission above 18GHz were not included is because their levels are too low.

Site : CB4-H	Time : 2017/05/26
Limit : FCC_Part22/24_00M_00M_PK	Margin : 6
Probe : CB4-H_CE_Sub_B432_1-18GHz_3M_1116 - HORIZONTAL	Power : DC 24V
EUT : 3G Cellular Alarm Communicator	Note : Mode 1: GPRS 850_Link_848.8MHz

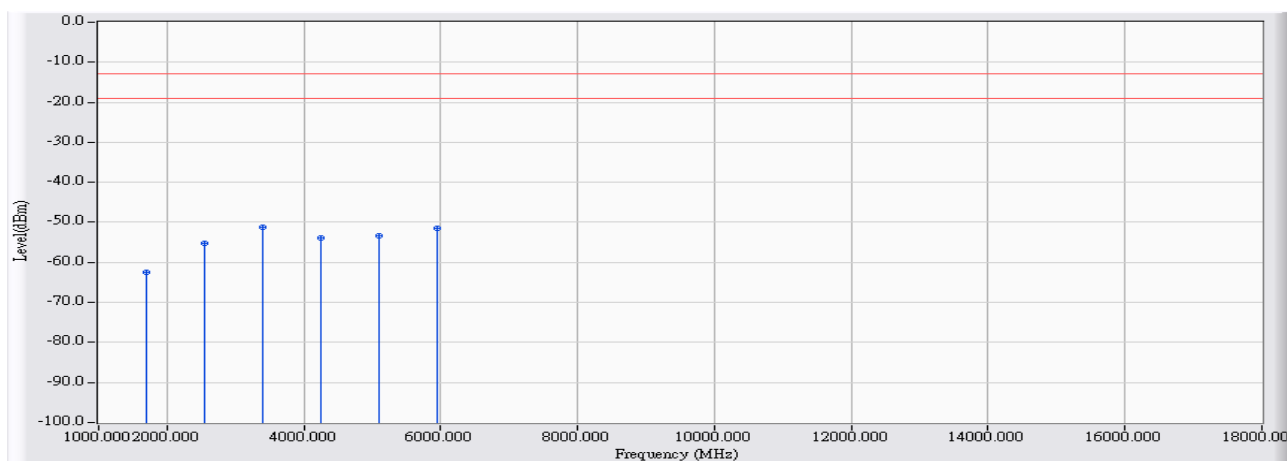

	Frequency (MHz)	Correct Factor (dB)	Reading Level (dBm)	Measure Level (dBm)	Margin (dB)	Limit (dBm)	Detector Type
1	1697.600	2.441	-65.030	-62.589	-49.589	-13.000	PEAK
2	2546.400	7.535	-62.840	-55.304	-42.304	-13.000	PEAK
3	* 3395.200	10.488	-61.680	-51.192	-38.192	-13.000	PEAK
4	4244.000	12.291	-66.290	-54.000	-41.000	-13.000	PEAK
5	5092.800	13.701	-67.160	-53.459	-40.459	-13.000	PEAK
6	5941.600	16.050	-67.650	-51.600	-38.600	-13.000	PEAK

Note:

1. All readings above 1GHz are performed with peak and/or average measurements as necessary.
2. Peak measurements: RBW = 1MHz, VBW = 1MHz, Sweep: Auto.
3. Average measurements: RBW = 1MHz, VBW = 10 Hz, Sweep: Auto.
4. “ \* ”, means this data is the worst emission level.
5. Measurement Level = Reading Level + Correct Factor.
6. The average measurement was not performed when the peak measured data under the limit of average detection.
7. The Emission above 18GHz were not included is because their levels are too low.

Site : CB4-H	Time : 2017/05/26
Limit : FCC_Part22/24_00M_00M_PK	Margin : 6
Probe : CB4-H_CE_Sub_B432_1-18GHz_3M_1116 - VERTICAL	Power : DC 24V
EUT : 3G Cellular Alarm Communicator	Note : Mode 1: GPRS 850_Link_848.8MHz

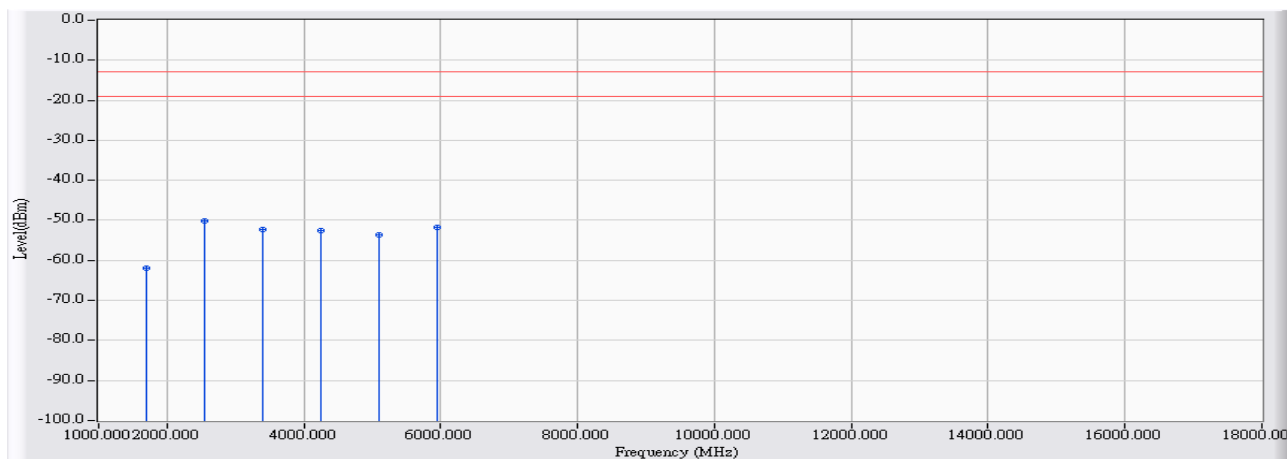

		Frequency (MHz)	Correct Factor (dB)	Reading Level (dBm)	Measure Level (dBm)	Margin (dB)	Limit (dBm)	Detector Type
1		1697.600	3.051	-64.930	-61.879	-48.879	-13.000	PEAK
2	*	2546.400	7.911	-57.940	-50.029	-37.029	-13.000	PEAK
3		3395.200	11.187	-63.560	-52.373	-39.373	-13.000	PEAK
4		4244.000	13.322	-65.900	-52.579	-39.579	-13.000	PEAK
5		5092.800	13.372	-66.900	-53.529	-40.529	-13.000	PEAK
6		5941.600	15.873	-67.570	-51.697	-38.697	-13.000	PEAK

Note:

1. All readings above 1GHz are performed with peak and/or average measurements as necessary.
2. Peak measurements: RBW = 1MHz, VBW = 1MHz, Sweep: Auto.
3. Average measurements: RBW = 1MHz, VBW = 10 Hz, Sweep: Auto.
4. “ \* ”, means this data is the worst emission level.
5. Measurement Level = Reading Level + Correct Factor.
6. The average measurement was not performed when the peak measured data under the limit of average detection.
7. The Emission above 18GHz were not included is because their levels are too low.



Site : CB4-H	Time : 2017/05/26
Limit : FCC_Part22/24_00M_00M_PK	Margin : 6
Probe : CB4-H_CE_Sub_B432_1-18GHz_3M_1116 - HORIZONTAL	Power : DC 24V
EUT : 3G Cellular Alarm Communicator	Note : Mode 2: GPRS 1900_Link_1850.2MHz

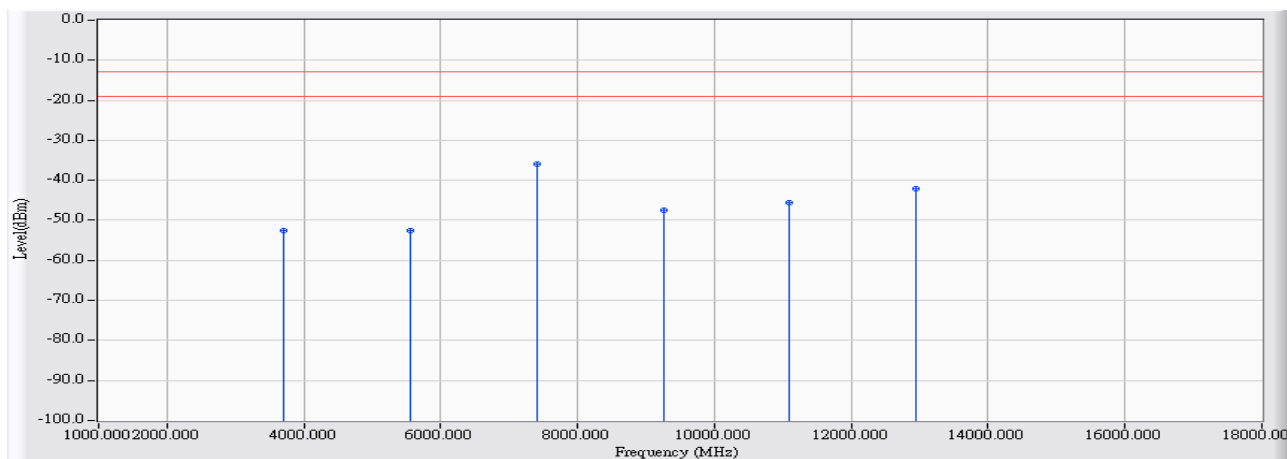

	Frequency (MHz)	Correct Factor (dB)	Reading Level (dBm)	Measure Level (dBm)	Margin (dB)	Limit (dBm)	Detector Type
1	3700.400	11.325	-63.840	-52.515	-39.515	-13.000	PEAK
2	5550.600	14.326	-66.910	-52.583	-39.583	-13.000	PEAK
3	* 7400.800	21.575	-57.580	-36.005	-23.005	-13.000	PEAK
4	9251.000	24.772	-72.260	-47.487	-34.487	-13.000	PEAK
5	11101.200	27.845	-73.460	-45.614	-32.614	-13.000	PEAK
6	12951.400	31.526	-73.620	-42.095	-29.095	-13.000	PEAK

Note:

1. All readings above 1GHz are performed with peak and/or average measurements as necessary.
2. Peak measurements: RBW = 1MHz, VBW = 1MHz, Sweep: Auto.
3. Average measurements: RBW = 1MHz, VBW = 10 Hz, Sweep: Auto.
4. “ \* ”, means this data is the worst emission level.
5. Measurement Level = Reading Level + Correct Factor.
6. The average measurement was not performed when the peak measured data under the limit of average detection.
7. The Emission above 18GHz were not included is because their levels are too low.

Site : CB4-H	Time : 2017/05/26
Limit : FCC_Part22/24_00M_00M_PK	Margin : 6
Probe : CB4-H_CE_Sub_B432_1-18GHz_3M_1116 - VERTICAL	Power : DC 24V
EUT : 3G Cellular Alarm Communicator	Note : Mode 2: GPRS 1900_Link_1850.2MHz

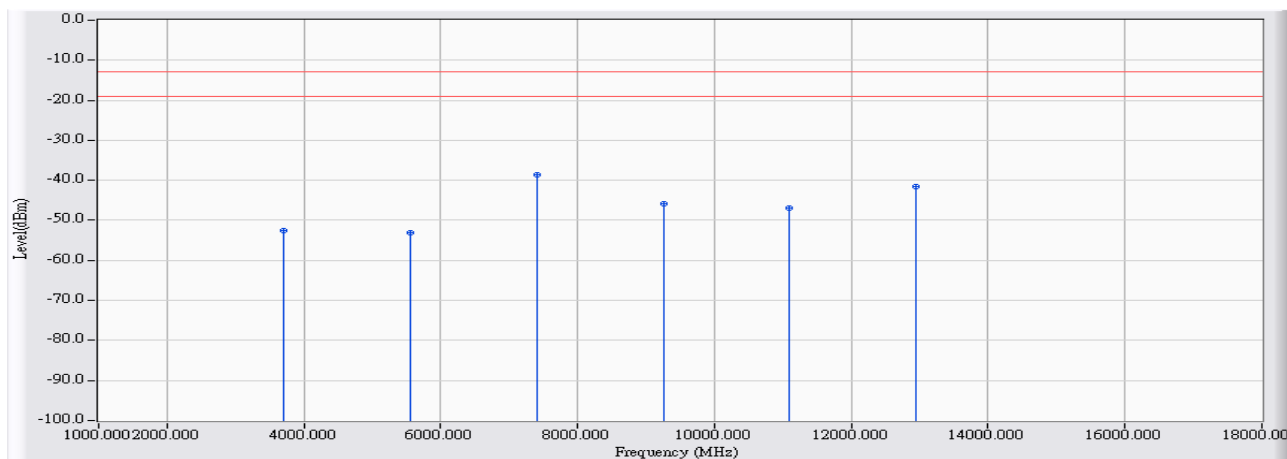

	Frequency (MHz)	Correct Factor (dB)	Reading Level (dBm)	Measure Level (dBm)	Margin (dB)	Limit (dBm)	Detector Type
1	3700.400	12.126	-64.760	-52.634	-39.634	-13.000	PEAK
2	5550.600	14.173	-67.310	-53.137	-40.137	-13.000	PEAK
3	* 7400.800	21.360	-59.900	-38.540	-25.540	-13.000	PEAK
4	9251.000	26.029	-71.840	-45.811	-32.811	-13.000	PEAK
5	11101.200	26.719	-73.650	-46.931	-33.931	-13.000	PEAK
6	12951.400	32.729	-74.180	-41.451	-28.451	-13.000	PEAK

Note:

1. All readings above 1GHz are performed with peak and/or average measurements as necessary.
2. Peak measurements: RBW = 1MHz, VBW = 1MHz, Sweep: Auto.
3. Average measurements: RBW = 1MHz, VBW = 10 Hz, Sweep: Auto.
4. “ \* ”, means this data is the worst emission level.
5. Measurement Level = Reading Level + Correct Factor.
6. The average measurement was not performed when the peak measured data under the limit of average detection.
7. The Emission above 18GHz were not included is because their levels are too low.

Site : CB4-H	Time : 2017/05/26
Limit : FCC_Part22/24_00M_00M_PK	Margin : 6
Probe : CB4-H_CE_Sub_B432_1-18GHz_3M_1116 - HORIZONTAL	Power : DC 24V
EUT : 3G Cellular Alarm Communicator	Note : Mode 2: GPRS 1900_Link_1880MHz

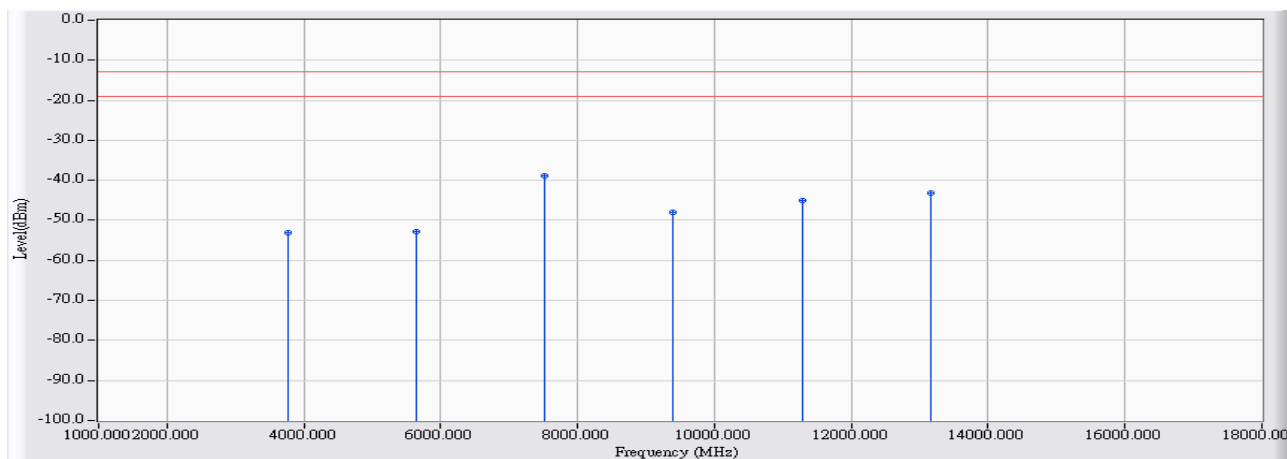

	Frequency (MHz)	Correct Factor (dB)	Reading Level (dBm)	Measure Level (dBm)	Margin (dB)	Limit (dBm)	Detector Type
1	3760.000	11.489	-64.570	-53.082	-40.082	-13.000	PEAK
2	5640.000	14.733	-67.480	-52.747	-39.747	-13.000	PEAK
3	* 7520.000	21.729	-60.730	-39.001	-26.001	-13.000	PEAK
4	9400.000	24.813	-72.680	-47.866	-34.866	-13.000	PEAK
5	11280.000	28.021	-72.980	-44.958	-31.958	-13.000	PEAK
6	13160.000	31.455	-74.540	-43.085	-30.085	-13.000	PEAK

Note:

1. All readings above 1GHz are performed with peak and/or average measurements as necessary.
2. Peak measurements: RBW = 1MHz, VBW = 1MHz, Sweep: Auto.
3. Average measurements: RBW = 1MHz, VBW = 10 Hz, Sweep: Auto.
4. “ \* ”, means this data is the worst emission level.
5. Measurement Level = Reading Level + Correct Factor.
6. The average measurement was not performed when the peak measured data under the limit of average detection.
7. The Emission above 18GHz were not included is because their levels are too low.

Site : CB4-H	Time : 2017/05/26
Limit : FCC_Part22/24_00M_00M_PK	Margin : 6
Probe : CB4-H_CE_Sub_B432_1-18GHz_3M_1116 - VERTICAL	Power : DC 24V
EUT : 3G Cellular Alarm Communicator	Note : Mode 2: GPRS 1900_Link_1880MHz

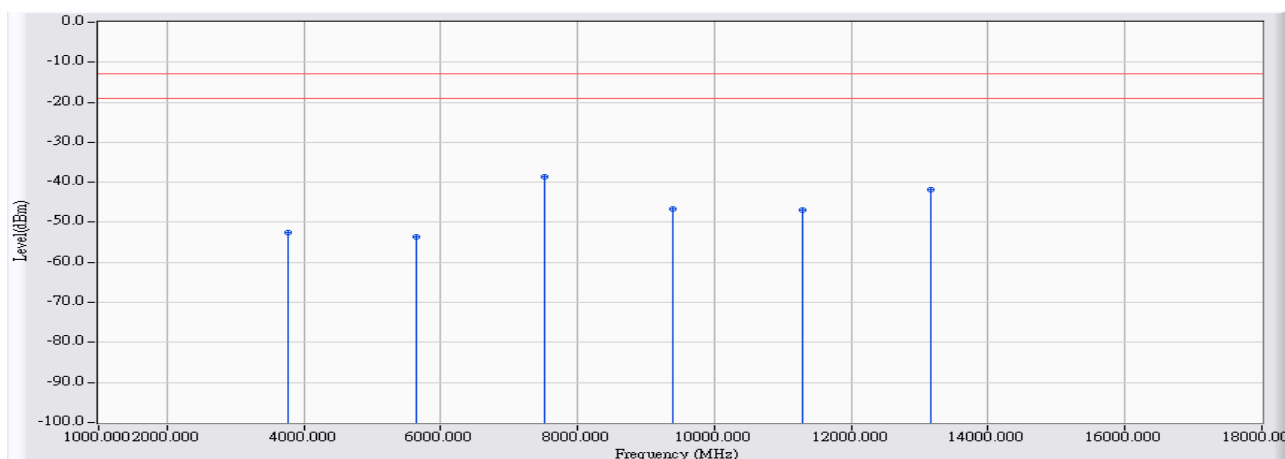

	Frequency (MHz)	Correct Factor (dB)	Reading Level (dBm)	Measure Level (dBm)	Margin (dB)	Limit (dBm)	Detector Type
1	3760.000	12.281	-64.960	-52.680	-39.680	-13.000	PEAK
2	5640.000	14.575	-68.070	-53.495	-40.495	-13.000	PEAK
3	* 7520.000	21.815	-60.380	-38.566	-25.566	-13.000	PEAK
4	9400.000	26.275	-72.810	-46.534	-33.534	-13.000	PEAK
5	11280.000	27.395	-74.290	-46.894	-33.894	-13.000	PEAK
6	13160.000	32.775	-74.670	-41.895	-28.895	-13.000	PEAK

Note:

1. All readings above 1GHz are performed with peak and/or average measurements as necessary.
2. Peak measurements: RBW = 1MHz, VBW = 1MHz, Sweep: Auto.
3. Average measurements: RBW = 1MHz, VBW = 10 Hz, Sweep: Auto.
4. “ \* ”, means this data is the worst emission level.
5. Measurement Level = Reading Level + Correct Factor.
6. The average measurement was not performed when the peak measured data under the limit of average detection.
7. The Emission above 18GHz were not included is because their levels are too low.

Site : CB4-H	Time : 2017/05/26
Limit : FCC_Part22/24_00M_00M_PK	Margin : 6
Probe : CB4-H_CE_Sub_B432_1-18GHz_3M_1116 - HORIZONTAL	Power : DC 24V
EUT : 3G Cellular Alarm Communicator	Note : Mode 2: GPRS 1900_Link_1909.8MHz

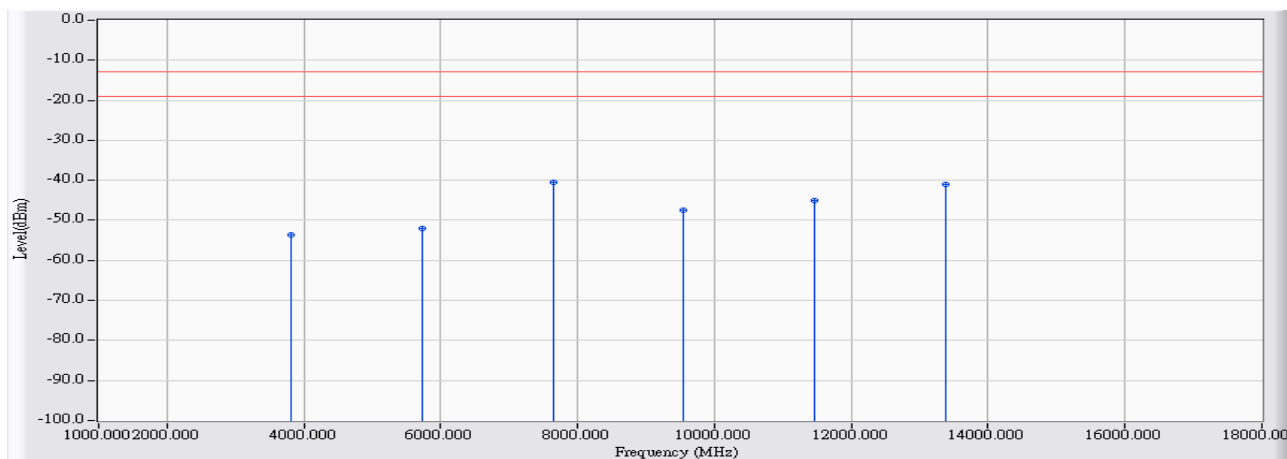

	Frequency (MHz)	Correct Factor (dB)	Reading Level (dBm)	Measure Level (dBm)	Margin (dB)	Limit (dBm)	Detector Type
1	3819.600	11.595	-65.280	-53.686	-40.686	-13.000	PEAK
2	5729.400	15.140	-67.270	-52.130	-39.130	-13.000	PEAK
3	* 7639.200	22.230	-62.660	-40.430	-27.430	-13.000	PEAK
4	9549.000	25.003	-72.410	-47.407	-34.407	-13.000	PEAK
5	11458.800	28.602	-73.740	-45.138	-32.138	-13.000	PEAK
6	13368.600	31.812	-72.920	-41.108	-28.108	-13.000	PEAK

Note:

1. All readings above 1GHz are performed with peak and/or average measurements as necessary.
2. Peak measurements: RBW = 1MHz, VBW = 1MHz, Sweep: Auto.
3. Average measurements: RBW = 1MHz, VBW = 10 Hz, Sweep: Auto.
4. “ \* ”, means this data is the worst emission level.
5. Measurement Level = Reading Level + Correct Factor.
6. The average measurement was not performed when the peak measured data under the limit of average detection.
7. The Emission above 18GHz were not included is because their levels are too low.

Site : CB4-H	Time : 2017/05/26
Limit : FCC_Part22/24_00M_00M_PK	Margin : 6
Probe : CB4-H_CE_Sub_B432_1-18GHz_3M_1116 - VERTICAL	Power : DC 24V
EUT : 3G Cellular Alarm Communicator	Note : Mode 2: GPRS 1900_Link_1909.8MHz

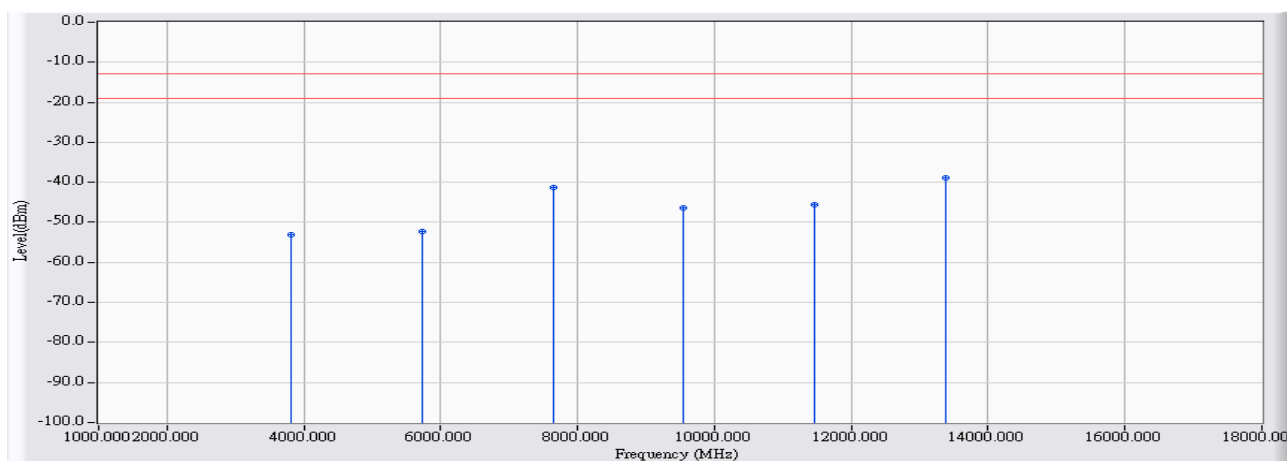

		Frequency (MHz)	Correct Factor (dB)	Reading Level (dBm)	Measure Level (dBm)	Margin (dB)	Limit (dBm)	Detector Type
1		3819.600	12.365	-65.480	-53.115	-40.115	-13.000	PEAK
2		5729.400	14.977	-67.310	-52.333	-39.333	-13.000	PEAK
3		7639.200	22.110	-63.390	-41.280	-28.280	-13.000	PEAK
4		9549.000	26.522	-73.000	-46.478	-33.478	-13.000	PEAK
5		11458.800	28.476	-73.960	-45.484	-32.484	-13.000	PEAK
6	*	13368.800	33.353	-72.330	-38.976	-25.976	-13.000	PEAK

Note:

1. All readings above 1GHz are performed with peak and/or average measurements as necessary.
2. Peak measurements: RBW = 1MHz, VBW = 1MHz, Sweep: Auto.
3. Average measurements: RBW = 1MHz, VBW = 10 Hz, Sweep: Auto.
4. “ \* ”, means this data is the worst emission level.
5. Measurement Level = Reading Level + Correct Factor.
6. The average measurement was not performed when the peak measured data under the limit of average detection.
7. The Emission above 18GHz were not included is because their levels are too low.

Site : CB4-H	Time : 2017/05/26
Limit : FCC_Part22/24_00M_00M_PK	Margin : 6
Probe : CB4-H_CE_Sub_B432_1-18GHz_3M_1116 - HORIZONTAL	Power : DC 24V
EUT : 3G Cellular Alarm Communicator	Note : Mode 3: EGPRS 850_Link_824.2MHz

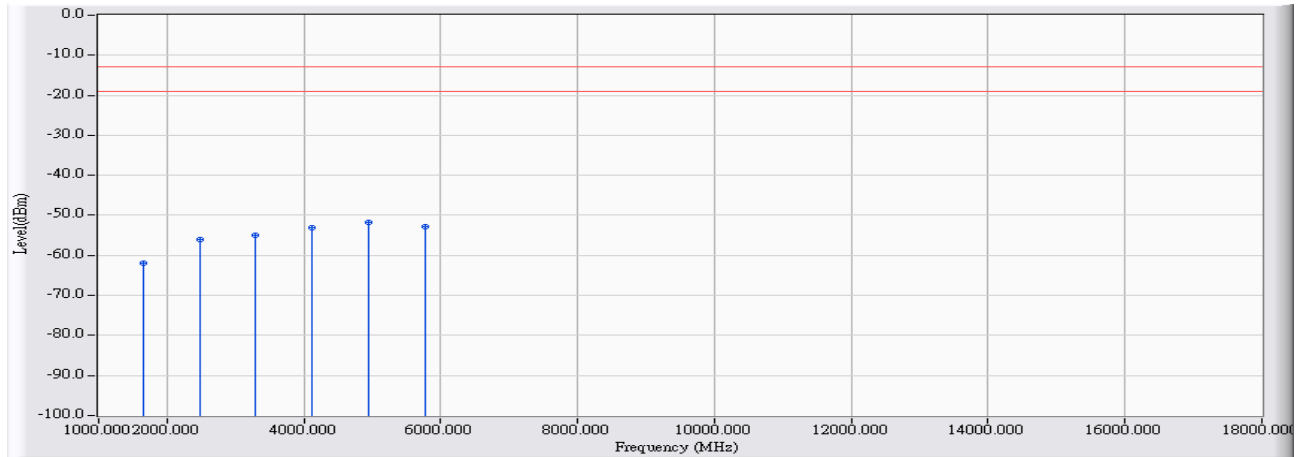

	Frequency (MHz)	Correct Factor (dB)	Reading Level (dBm)	Measure Level (dBm)	Margin (dB)	Limit (dBm)	Detector Type
1	1648.400	2.526	-64.540	-62.015	-49.015	-13.000	PEAK
2	2472.600	7.434	-63.410	-55.977	-42.977	-13.000	PEAK
3	3296.800	10.254	-65.170	-54.917	-41.917	-13.000	PEAK
4	4121.000	12.098	-65.090	-52.992	-39.992	-13.000	PEAK
5	* 4945.200	15.801	-67.630	-51.829	-38.829	-13.000	PEAK
6	5769.400	15.316	-68.200	-52.883	-39.883	-13.000	PEAK

Note:

1. All readings above 1GHz are performed with peak and/or average measurements as necessary.
2. Peak measurements: RBW = 1MHz, VBW = 1MHz, Sweep: Auto.
3. Average measurements: RBW = 1MHz, VBW = 10 Hz, Sweep: Auto.
4. “ \* ”, means this data is the worst emission level.
5. Measurement Level = Reading Level + Correct Factor.
6. The average measurement was not performed when the peak measured data under the limit of average detection.
7. The Emission above 18GHz were not included is because their levels are too low.

Site : CB4-H	Time : 2017/05/26
Limit : FCC_Part22/24_00M_00M_PK	Margin : 6
Probe : CB4-H_CE_Sub_B432_1-18GHz_3M_1116 - VERTICAL	Power : DC 24V
EUT : 3G Cellular Alarm Communicator	Note : Mode 3: EGPRS 850_Link_824.2MHz

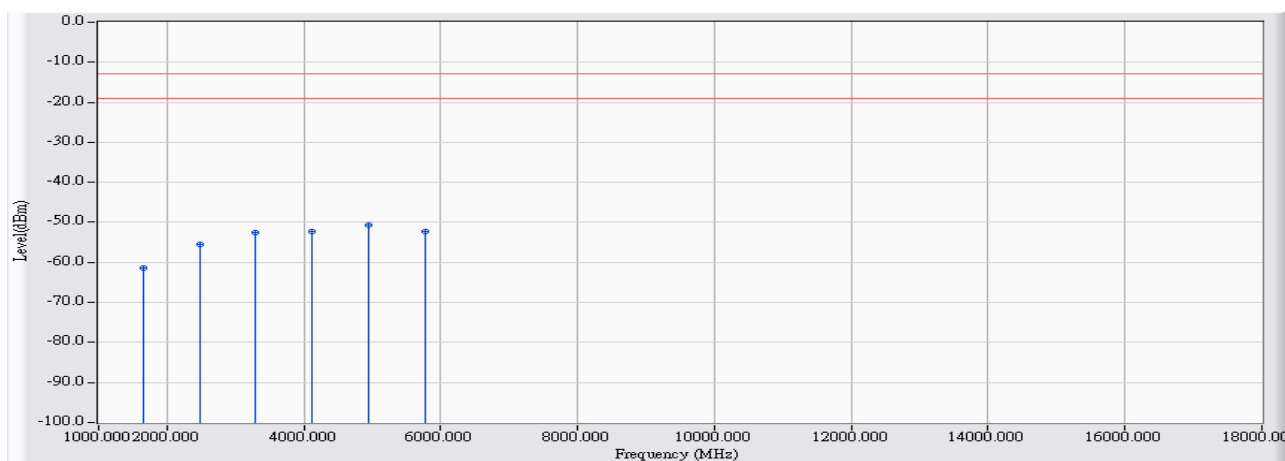

	Frequency (MHz)	Correct Factor (dB)	Reading Level (dBm)	Measure Level (dBm)	Margin (dB)	Limit (dBm)	Detector Type
1	1648.400	3.046	-64.560	-61.515	-48.515	-13.000	PEAK
2	2472.600	7.770	-63.210	-55.441	-42.441	-13.000	PEAK
3	3296.800	10.836	-63.330	-52.495	-39.495	-13.000	PEAK
4	4121.000	12.965	-65.180	-52.215	-39.215	-13.000	PEAK
5	* 4945.200	16.320	-67.100	-50.780	-37.780	-13.000	PEAK
6	5769.400	15.150	-67.560	-52.410	-39.410	-13.000	PEAK

Note:

1. All readings above 1GHz are performed with peak and/or average measurements as necessary.
2. Peak measurements: RBW = 1MHz, VBW = 1MHz, Sweep: Auto.
3. Average measurements: RBW = 1MHz, VBW = 10 Hz, Sweep: Auto.
4. “ \* ”, means this data is the worst emission level.
5. Measurement Level = Reading Level + Correct Factor.
6. The average measurement was not performed when the peak measured data under the limit of average detection.
7. The Emission above 18GHz were not included is because their levels are too low.



Site : CB4-H	Time : 2017/05/26
Limit : FCC_Part22/24_00M_00M_PK	Margin : 6
Probe : CB4-H_CE_Sub_B432_1-18GHz_3M_1116 - HORIZONTAL	Power : DC 24V
EUT : 3G Cellular Alarm Communicator	Note : Mode 3: EGPRS 850_Link_836.6MHz

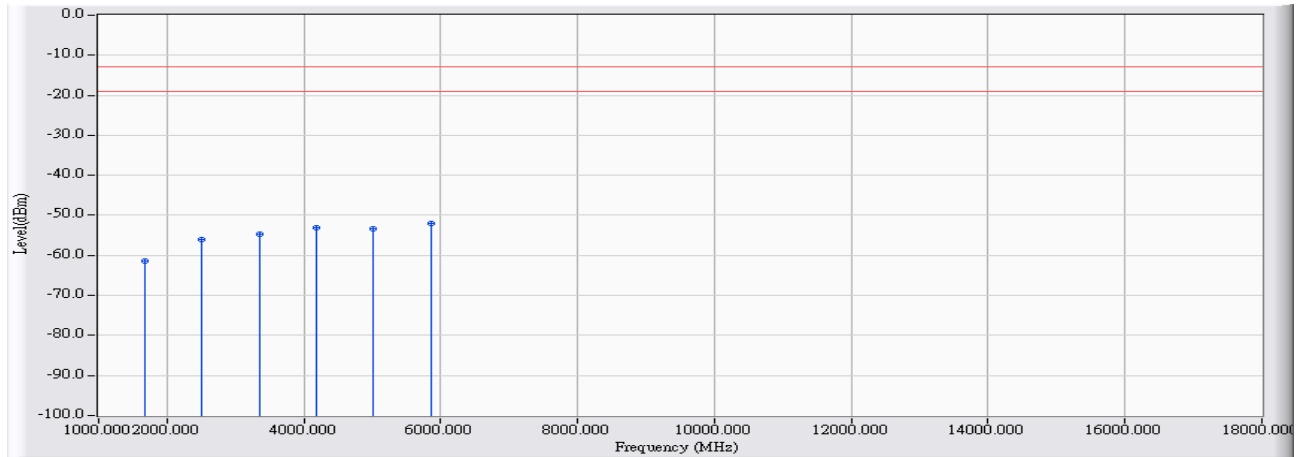

		Frequency (MHz)	Correct Factor (dB)	Reading Level (dBm)	Measure Level (dBm)	Margin (dB)	Limit (dBm)	Detector Type
1		1673.200	2.482	-63.780	-61.297	-48.297	-13.000	PEAK
2		2509.800	7.420	-63.330	-55.910	-42.910	-13.000	PEAK
3		3346.400	10.371	-64.990	-54.618	-41.618	-13.000	PEAK
4		4183.000	12.197	-65.330	-53.133	-40.133	-13.000	PEAK
5		5019.600	13.621	-66.850	-53.228	-40.228	-13.000	PEAK
6	*	5856.200	15.687	-67.780	-52.094	-39.094	-13.000	PEAK

Note:

1. All readings above 1GHz are performed with peak and/or average measurements as necessary.
2. Peak measurements: RBW = 1MHz, VBW = 1MHz, Sweep: Auto.
3. Average measurements: RBW = 1MHz, VBW = 10 Hz, Sweep: Auto.
4. “ \* ”, means this data is the worst emission level.
5. Measurement Level = Reading Level + Correct Factor.
6. The average measurement was not performed when the peak measured data under the limit of average detection.
7. The Emission above 18GHz were not included is because their levels are too low.

Site : CB4-H	Time : 2017/05/26
Limit : FCC_Part22/24_00M_00M_PK	Margin : 6
Probe : CB4-H_CE_Sub_B432_1-18GHz_3M_1116 - VERTICAL	Power : DC 24V
EUT : 3G Cellular Alarm Communicator	Note : Mode 3: EGPRS 850_Link_836.6MHz

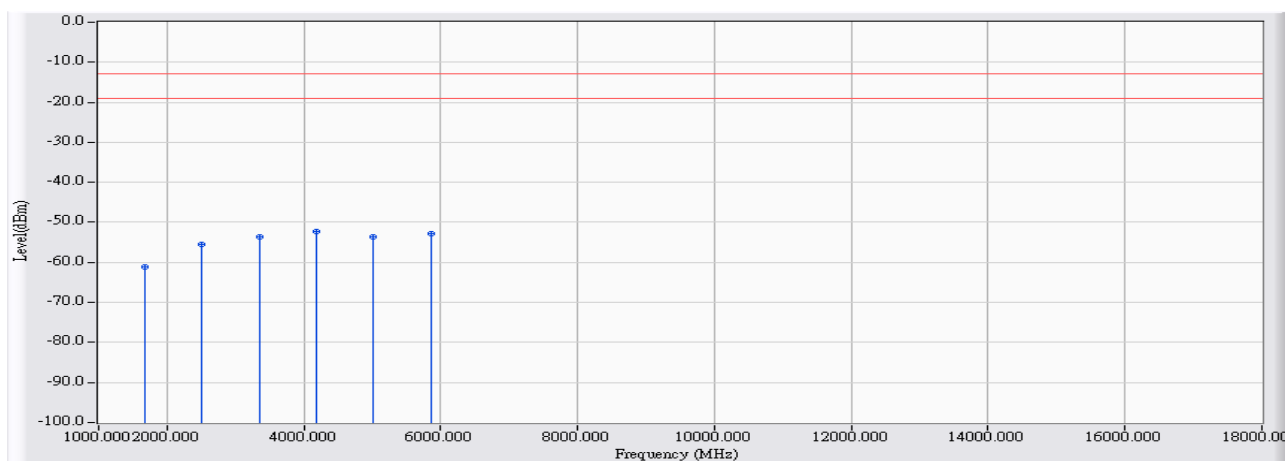

	Frequency (MHz)	Correct Factor (dB)	Reading Level (dBm)	Measure Level (dBm)	Margin (dB)	Limit (dBm)	Detector Type
1	1673.200	3.047	-64.230	-61.182	-48.182	-13.000	PEAK
2	2509.800	7.809	-63.260	-55.451	-42.451	-13.000	PEAK
3	3346.400	11.012	-64.760	-53.747	-40.747	-13.000	PEAK
4	* 4183.000	13.147	-65.440	-52.293	-39.293	-13.000	PEAK
5	5019.600	13.260	-66.750	-53.489	-40.489	-13.000	PEAK
6	5856.200	15.515	-68.440	-52.925	-39.925	-13.000	PEAK

Note:

1. All readings above 1GHz are performed with peak and/or average measurements as necessary.
2. Peak measurements: RBW = 1MHz, VBW = 1MHz, Sweep: Auto.
3. Average measurements: RBW = 1MHz, VBW = 10 Hz, Sweep: Auto.
4. “ \* ”, means this data is the worst emission level.
5. Measurement Level = Reading Level + Correct Factor.
6. The average measurement was not performed when the peak measured data under the limit of average detection.
7. The Emission above 18GHz were not included is because their levels are too low.

Site : CB4-H	Time : 2017/05/26
Limit : FCC_Part22/24_00M_00M_PK	Margin : 6
Probe : CB4-H_CE_Sub_B432_1-18GHz_3M_1116 - HORIZONTAL	Power : DC 24V
EUT : 3G Cellular Alarm Communicator	Note : Mode 3: EGPRS 850_Link_848.8MHz

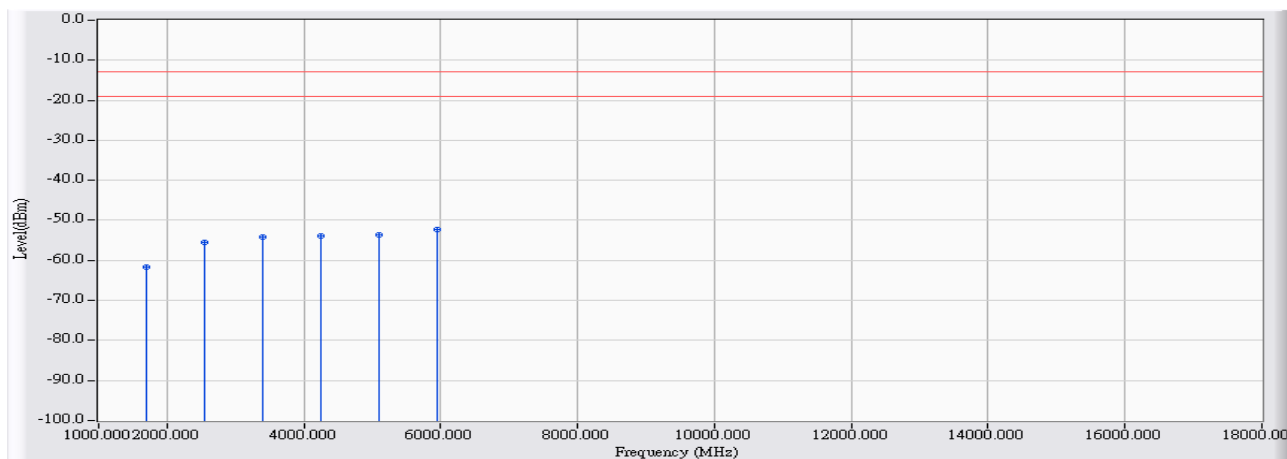

		Frequency (MHz)	Correct Factor (dB)	Reading Level (dBm)	Measure Level (dBm)	Margin (dB)	Limit (dBm)	Detector Type
1		1697.600	2.441	-64.140	-61.699	-48.699	-13.000	PEAK
2		2546.400	7.535	-62.960	-55.424	-42.424	-13.000	PEAK
3		3395.200	10.488	-64.750	-54.262	-41.262	-13.000	PEAK
4		4244.000	12.291	-66.080	-53.790	-40.790	-13.000	PEAK
5		5092.800	13.701	-67.210	-53.509	-40.509	-13.000	PEAK
6	*	5941.600	16.050	-68.350	-52.300	-39.300	-13.000	PEAK

Note:

1. All readings above 1GHz are performed with peak and/or average measurements as necessary.
2. Peak measurements: RBW = 1MHz, VBW = 1MHz, Sweep: Auto.
3. Average measurements: RBW = 1MHz, VBW = 10 Hz, Sweep: Auto.
4. “ \* ”, means this data is the worst emission level.
5. Measurement Level = Reading Level + Correct Factor.
6. The average measurement was not performed when the peak measured data under the limit of average detection.
7. The Emission above 18GHz were not included is because their levels are too low.

Site : CB4-H	Time : 2017/05/26
Limit : FCC_Part22/24_00M_00M_PK	Margin : 6
Probe : CB4-H_CE_Sub_B432_1-18GHz_3M_1116 - VERTICAL	Power : DC 24V
EUT : 3G Cellular Alarm Communicator	Note : Mode 3: EGPRS 850_Link_848.8MHz

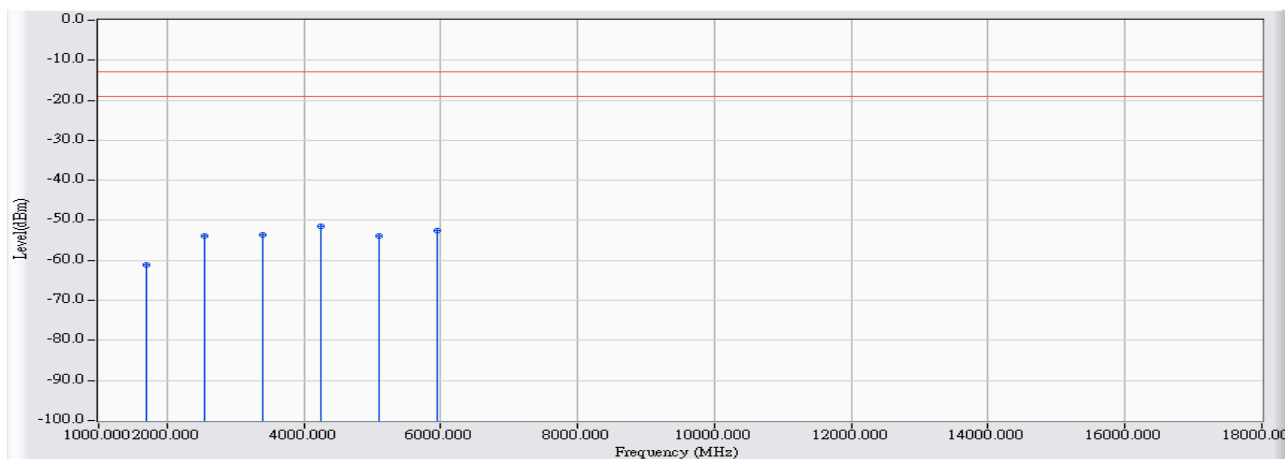

	Frequency (MHz)	Correct Factor (dB)	Reading Level (dBm)	Measure Level (dBm)	Margin (dB)	Limit (dBm)	Detector Type
1	1697.600	3.051	-64.280	-61.229	-48.229	-13.000	PEAK
2	2546.400	7.911	-61.870	-53.959	-40.959	-13.000	PEAK
3	3395.200	11.187	-64.880	-53.693	-40.693	-13.000	PEAK
4	* 4244.000	13.322	-64.810	-51.489	-38.489	-13.000	PEAK
5	5092.800	13.372	-67.320	-53.949	-40.949	-13.000	PEAK
6	5941.600	15.873	-68.290	-52.417	-39.417	-13.000	PEAK

Note:

1. All readings above 1GHz are performed with peak and/or average measurements as necessary.
2. Peak measurements: RBW = 1MHz, VBW = 1MHz, Sweep: Auto.
3. Average measurements: RBW = 1MHz, VBW = 10 Hz, Sweep: Auto.
4. “ \* ”, means this data is the worst emission level.
5. Measurement Level = Reading Level + Correct Factor.
6. The average measurement was not performed when the peak measured data under the limit of average detection.
7. The Emission above 18GHz were not included is because their levels are too low.

Site : CB4-H	Time : 2017/05/26
Limit : FCC_Part22/24_00M_00M_PK	Margin : 6
Probe : CB4-H_CE_Sub_B432_1-18GHz_3M_1116 - HORIZONTAL	Power : DC 24V
EUT : 3G Cellular Alarm Communicator	Note : Mode 4: EGPRS 1900_Link_1850.2MHz

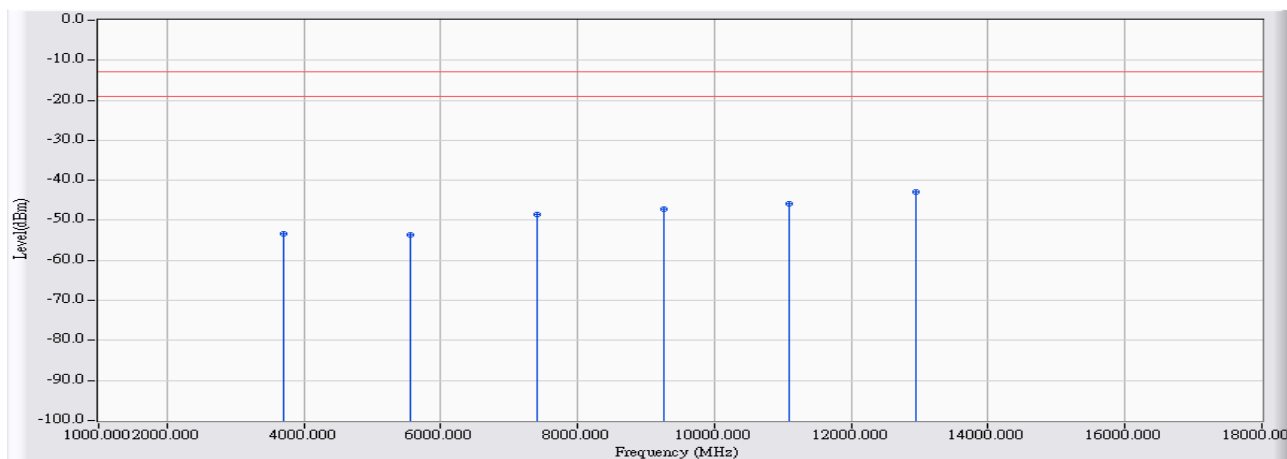

		Frequency (MHz)	Correct Factor (dB)	Reading Level (dBm)	Measure Level (dBm)	Margin (dB)	Limit (dBm)	Detector Type
1		3700.400	11.325	-64.790	-53.465	-40.465	-13.000	PEAK
2		5550.600	14.326	-67.900	-53.573	-40.573	-13.000	PEAK
3		7400.800	21.575	-70.100	-48.525	-35.525	-13.000	PEAK
4		9251.000	24.772	-71.880	-47.107	-34.107	-13.000	PEAK
5		11101.200	27.845	-73.620	-45.774	-32.774	-13.000	PEAK
6	*	12951.400	31.526	-74.290	-42.765	-29.765	-13.000	PEAK

Note:

1. All readings above 1GHz are performed with peak and/or average measurements as necessary.
2. Peak measurements: RBW = 1MHz, VBW = 1MHz, Sweep: Auto.
3. Average measurements: RBW = 1MHz, VBW = 10 Hz, Sweep: Auto.
4. “ \* ”, means this data is the worst emission level.
5. Measurement Level = Reading Level + Correct Factor.
6. The average measurement was not performed when the peak measured data under the limit of average detection.
7. The Emission above 18GHz were not included is because their levels are too low.

Site : CB4-H	Time : 2017/05/26
Limit : FCC_Part22/24_00M_00M_PK	Margin : 6
Probe : CB4-H_CE_Sub_B432_1-18GHz_3M_1116 - VERTICAL	Power : DC 24V
EUT : 3G Cellular Alarm Communicator	Note : Mode 4: EGPRS 1900_Link_1850.2MHz

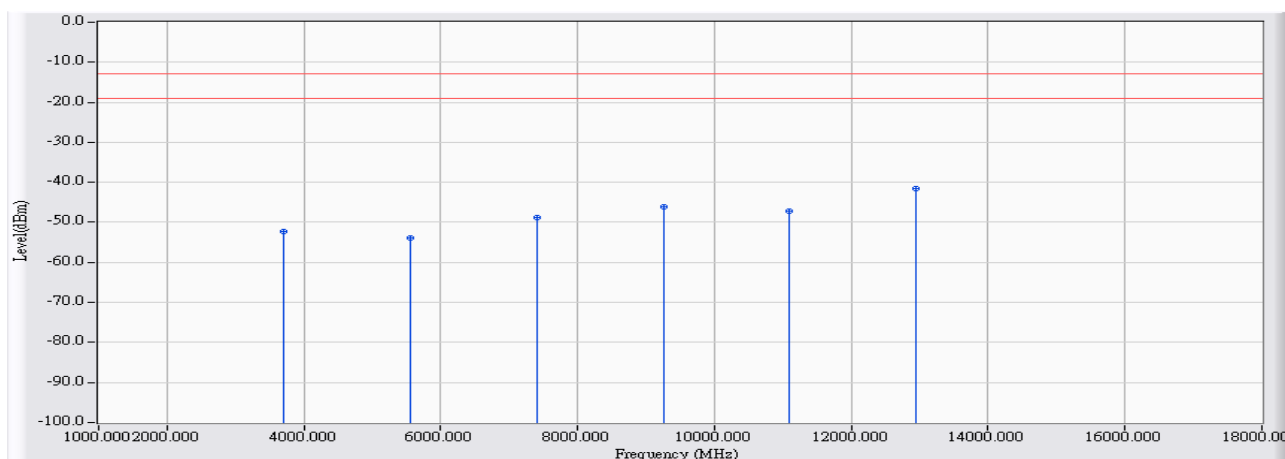

		Frequency (MHz)	Correct Factor (dB)	Reading Level (dBm)	Measure Level (dBm)	Margin (dB)	Limit (dBm)	Detector Type
1		3700.400	12.126	-64.460	-52.334	-39.334	-13.000	PEAK
2		5550.600	14.173	-67.980	-53.807	-40.807	-13.000	PEAK
3		7400.800	21.360	-70.230	-48.870	-35.870	-13.000	PEAK
4		9251.000	26.029	-72.180	-46.151	-33.151	-13.000	PEAK
5		11101.200	26.719	-73.890	-47.171	-34.171	-13.000	PEAK
6	*	12951.400	32.729	-74.250	-41.521	-28.521	-13.000	PEAK

Note:

1. All readings above 1GHz are performed with peak and/or average measurements as necessary.
2. Peak measurements: RBW = 1MHz, VBW = 1MHz, Sweep: Auto.
3. Average measurements: RBW = 1MHz, VBW = 10 Hz, Sweep: Auto.
4. “ \* ”, means this data is the worst emission level.
5. Measurement Level = Reading Level + Correct Factor.
6. The average measurement was not performed when the peak measured data under the limit of average detection.
7. The Emission above 18GHz were not included is because their levels are too low.

Site : CB4-H	Time : 2017/05/26
Limit : FCC_Part22/24_00M_00M_PK	Margin : 6
Probe : CB4-H_CE_Sub_B432_1-18GHz_3M_1116 - HORIZONTAL	Power : DC 24V
EUT : 3G Cellular Alarm Communicator	Note : Mode 4: EGPRS 1900_Link_1880MHz

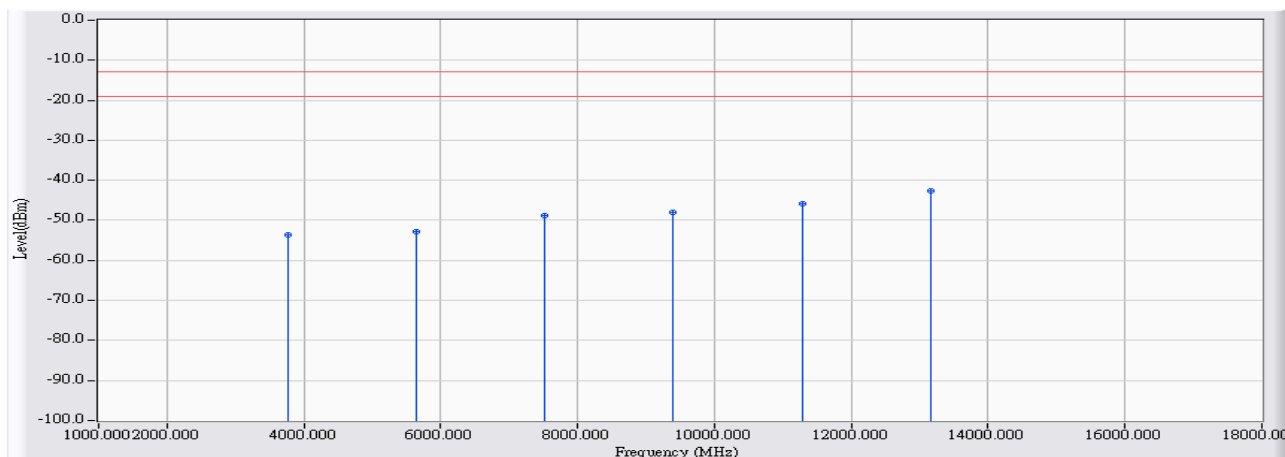

		Frequency (MHz)	Correct Factor (dB)	Reading Level (dBm)	Measure Level (dBm)	Margin (dB)	Limit (dBm)	Detector Type
1		3760.000	11.489	-65.000	-53.512	-40.512	-13.000	PEAK
2		5640.000	14.733	-67.550	-52.817	-39.817	-13.000	PEAK
3		7520.000	21.729	-70.570	-48.841	-35.841	-13.000	PEAK
4		9400.000	24.813	-72.830	-48.016	-35.016	-13.000	PEAK
5		11280.000	28.021	-73.800	-45.778	-32.778	-13.000	PEAK
6	*	13160.000	31.455	-73.970	-42.515	-29.515	-13.000	PEAK

Note:

1. All readings above 1GHz are performed with peak and/or average measurements as necessary.
2. Peak measurements: RBW = 1MHz, VBW = 1MHz, Sweep: Auto.
3. Average measurements: RBW = 1MHz, VBW = 10 Hz, Sweep: Auto.
4. “ \* ”, means this data is the worst emission level.
5. Measurement Level = Reading Level + Correct Factor.
6. The average measurement was not performed when the peak measured data under the limit of average detection.
7. The Emission above 18GHz were not included is because their levels are too low.

Site : CB4-H	Time : 2017/05/26
Limit : FCC_Part22/24_00M_00M_PK	Margin : 6
Probe : CB4-H_CE_Sub_B432_1-18GHz_3M_1116 - VERTICAL	Power : DC 24V
EUT : 3G Cellular Alarm Communicator	Note : Mode 4: EGPRS 1900_Link_1880MHz

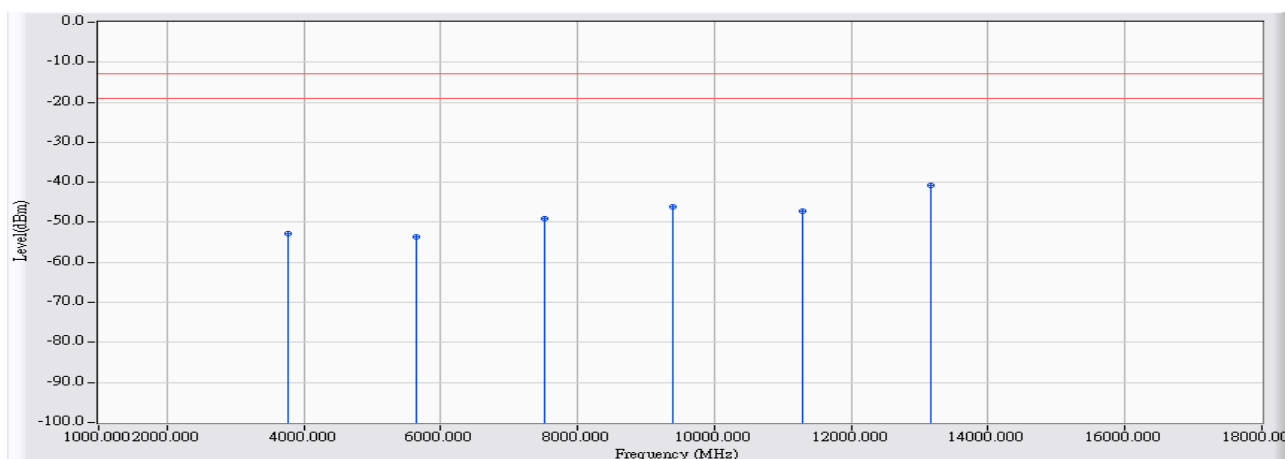

		Frequency (MHz)	Correct Factor (dB)	Reading Level (dBm)	Measure Level (dBm)	Margin (dB)	Limit (dBm)	Detector Type
1		3760.000	12.281	-65.220	-52.940	-39.940	-13.000	PEAK
2		5640.000	14.575	-68.250	-53.675	-40.675	-13.000	PEAK
3		7520.000	21.815	-70.920	-49.106	-36.106	-13.000	PEAK
4		9400.000	26.275	-72.520	-46.244	-33.244	-13.000	PEAK
5		11280.000	27.395	-74.480	-47.084	-34.084	-13.000	PEAK
6	*	13160.000	32.775	-73.600	-40.825	-27.825	-13.000	PEAK

Note:

1. All readings above 1GHz are performed with peak and/or average measurements as necessary.
2. Peak measurements: RBW = 1MHz, VBW = 1MHz, Sweep: Auto.
3. Average measurements: RBW = 1MHz, VBW = 10 Hz, Sweep: Auto.
4. “ \* ”, means this data is the worst emission level.
5. Measurement Level = Reading Level + Correct Factor.
6. The average measurement was not performed when the peak measured data under the limit of average detection.
7. The Emission above 18GHz were not included is because their levels are too low.



Site : CB4-H	Time : 2017/05/26
Limit : FCC_Part22/24_00M_00M_PK	Margin : 6
Probe : CB4-H_CE_Sub_B432_1-18GHz_3M_1116 - HORIZONTAL	Power : DC 24V
EUT : 3G Cellular Alarm Communicator	Note : Mode 4: EGPRS 1900_Link_1909.8MHz

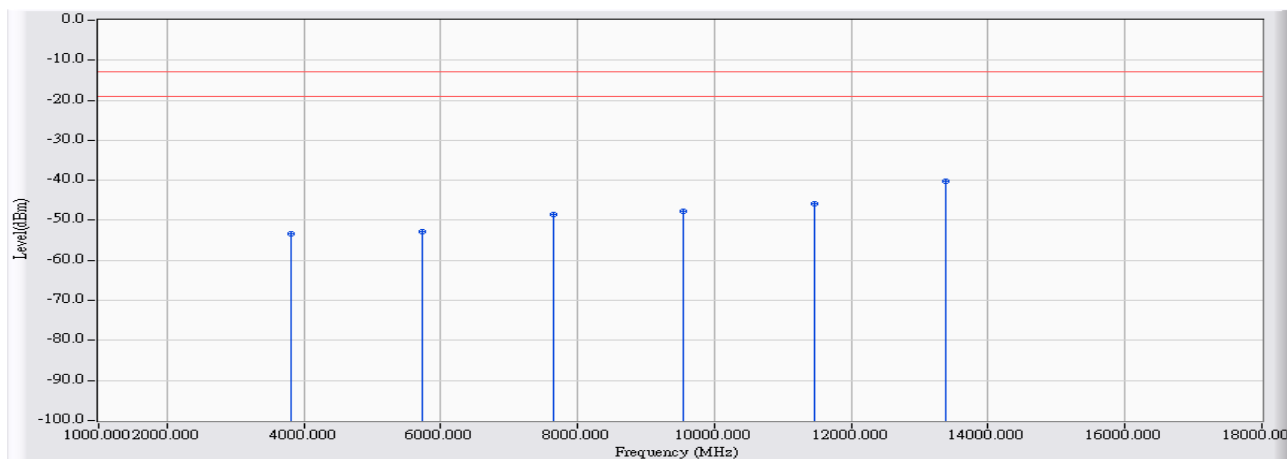

		Frequency (MHz)	Correct Factor (dB)	Reading Level (dBm)	Measure Level (dBm)	Margin (dB)	Limit (dBm)	Detector Type
1		3819.600	11.595	-64.910	-53.316	-40.316	-13.000	PEAK
2		5729.400	15.140	-67.860	-52.720	-39.720	-13.000	PEAK
3		7639.200	22.230	-70.630	-48.400	-35.400	-13.000	PEAK
4		9549.000	25.003	-72.820	-47.817	-34.817	-13.000	PEAK
5		11458.800	28.602	-74.360	-45.758	-32.758	-13.000	PEAK
6	*	13368.600	31.812	-72.140	-40.328	-27.328	-13.000	PEAK

Note:

1. All readings above 1GHz are performed with peak and/or average measurements as necessary.
2. Peak measurements: RBW = 1MHz, VBW = 1MHz, Sweep: Auto.
3. Average measurements: RBW = 1MHz, VBW = 10 Hz, Sweep: Auto.
4. “ \* ”, means this data is the worst emission level.
5. Measurement Level = Reading Level + Correct Factor.
6. The average measurement was not performed when the peak measured data under the limit of average detection.
7. The Emission above 18GHz were not included is because their levels are too low.

Site : CB4-H	Time : 2017/05/26
Limit : FCC_Part22/24_00M_00M_PK	Margin : 6
Probe : CB4-H_CE_Sub_B432_1-18GHz_3M_1116 - VERTICAL	Power : DC 24V
EUT : 3G Cellular Alarm Communicator	Note : Mode 4: EGPRS 1900_Link_1909.8MHz

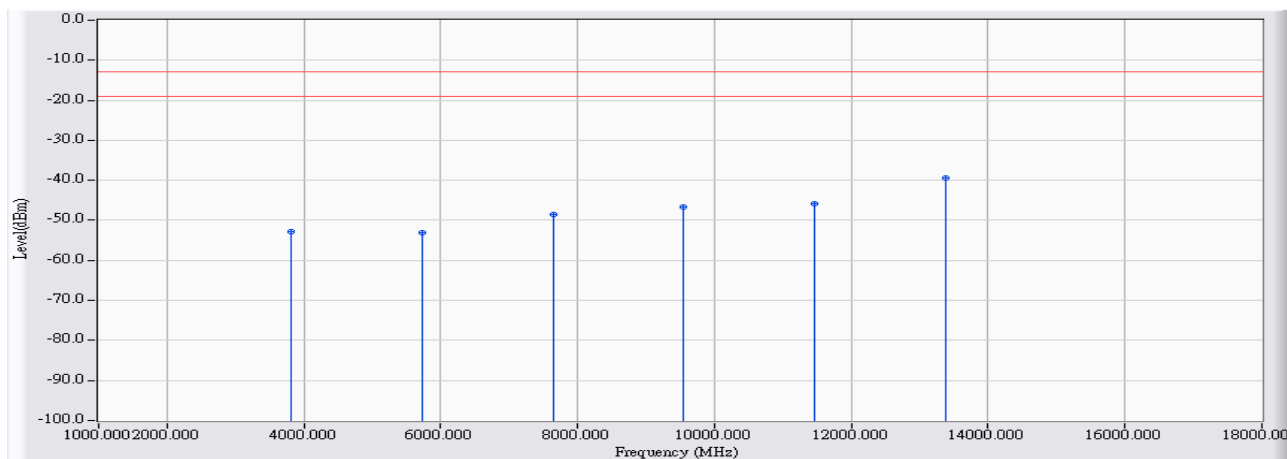

		Frequency (MHz)	Correct Factor (dB)	Reading Level (dBm)	Measure Level (dBm)	Margin (dB)	Limit (dBm)	Detector Type
1		3819.600	12.365	-65.060	-52.695	-39.695	-13.000	PEAK
2		5729.400	14.977	-67.990	-53.013	-40.013	-13.000	PEAK
3		7639.200	22.110	-70.660	-48.550	-35.550	-13.000	PEAK
4		9549.000	26.522	-73.270	-46.748	-33.748	-13.000	PEAK
5		11458.800	28.476	-74.210	-45.734	-32.734	-13.000	PEAK
6	*	13368.600	33.353	-72.820	-39.467	-26.467	-13.000	PEAK

Note:

1. All readings above 1GHz are performed with peak and/or average measurements as necessary.
2. Peak measurements: RBW = 1MHz, VBW = 1MHz, Sweep: Auto.
3. Average measurements: RBW = 1MHz, VBW = 10 Hz, Sweep: Auto.
4. “ \* ”, means this data is the worst emission level.
5. Measurement Level = Reading Level + Correct Factor.
6. The average measurement was not performed when the peak measured data under the limit of average detection.
7. The Emission above 18GHz were not included is because their levels are too low.

Site : CB4-H	Time : 2017/05/23
Limit : FCC_Part22/24_00M_00M_PK	Margin : 6
Probe : CB4-H_CE_Sub_B432_1-18GHz_3M_1116 - HORIZONTAL	Power : DC 24V
EUT : 3G Cellular Alarm Communicator	Note : Mode 5: WCDMA Band 5_Link_826.4MHz

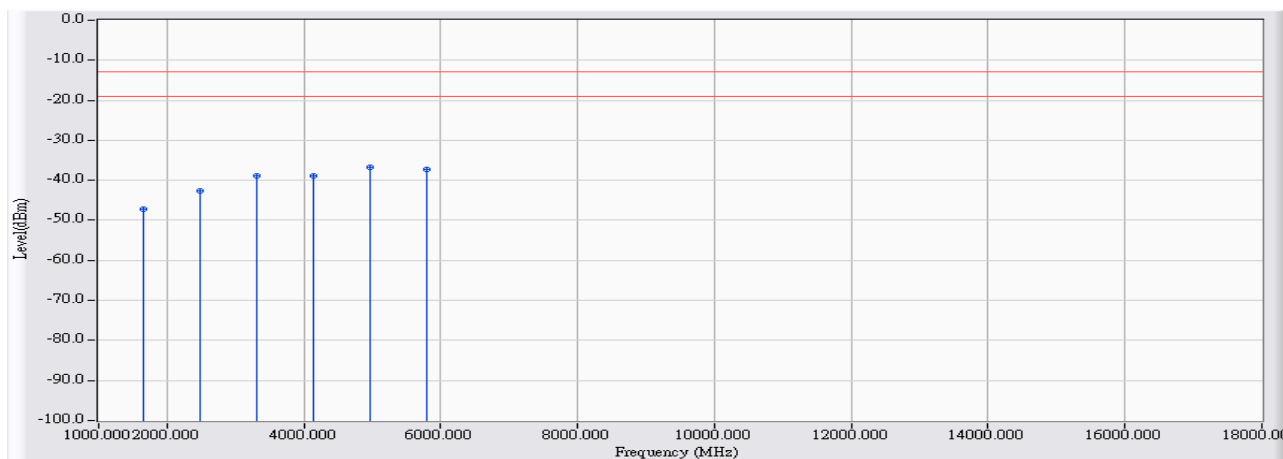

	Frequency (MHz)	Correct Factor (dB)	Reading Level (dBm)	Measure Level (dBm)	Margin (dB)	Limit (dBm)	Detector Type
1	1652.800	10.110	-57.220	-47.111	-34.111	-13.000	PEAK
2	2479.200	14.993	-57.510	-42.517	-29.517	-13.000	PEAK
3	3305.600	17.669	-56.580	-38.911	-25.911	-13.000	PEAK
4	4132.000	19.358	-58.360	-39.002	-26.002	-13.000	PEAK
5	* 4958.400	22.667	-59.430	-36.763	-23.763	-13.000	PEAK
6	5784.800	22.228	-59.420	-37.193	-24.193	-13.000	PEAK

Note:

1. All readings above 1GHz are performed with peak and/or average measurements as necessary.
2. Peak measurements: RBW = 1MHz, VBW = 1MHz, Sweep: Auto.
3. Average measurements: RBW = 1MHz, VBW = 10 Hz, Sweep: Auto.
4. “ \* ”, means this data is the worst emission level.
5. Measurement Level = Reading Level + Correct Factor.
6. The average measurement was not performed when the peak measured data under the limit of average detection.
7. The Emission above 18GHz were not included is because their levels are too low.

Site : CB4-H	Time : 2017/05/23
Limit : FCC_Part22/24_00M_00M_PK	Margin : 6
Probe : CB4-H_CE_Sub_B432_1-18GHz_3M_1116 - VERTICAL	Power : DC 24V
EUT : 3G Cellular Alarm Communicator	Note : Mode 5: WCDMA Band 5_Link_826.4MHz

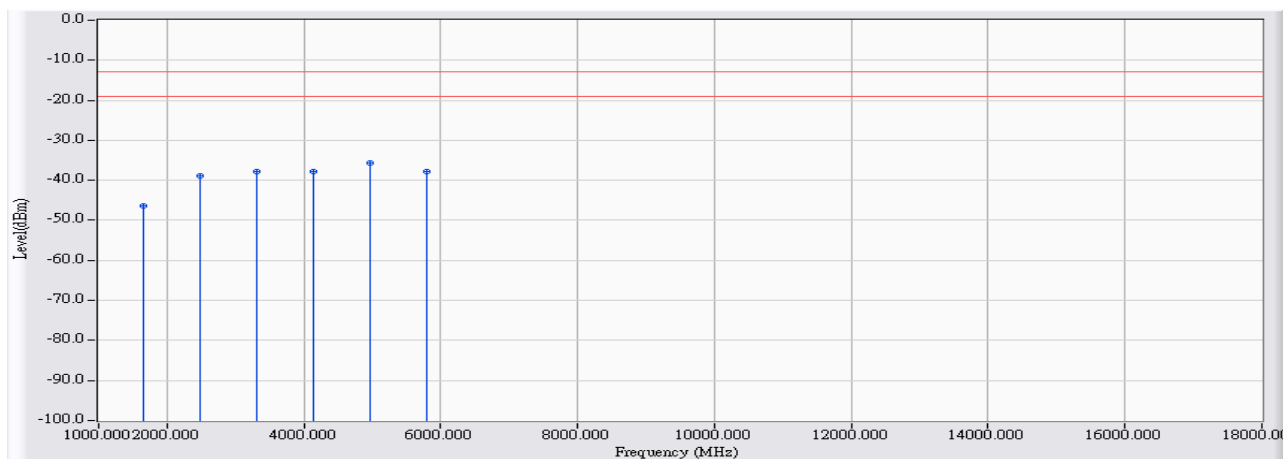

	Frequency (MHz)	Correct Factor (dB)	Reading Level (dBm)	Measure Level (dBm)	Margin (dB)	Limit (dBm)	Detector Type
1	1652.800	10.638	-57.050	-46.413	-33.413	-13.000	PEAK
2	2479.200	15.344	-54.320	-38.977	-25.977	-13.000	PEAK
3	3305.600	18.262	-56.070	-37.809	-24.809	-13.000	PEAK
4	4132.000	20.240	-58.140	-37.901	-24.901	-13.000	PEAK
5	* 4958.400	23.171	-58.920	-35.749	-22.749	-13.000	PEAK
6	5784.800	22.061	-59.740	-37.680	-24.680	-13.000	PEAK

Note:

1. All readings above 1GHz are performed with peak and/or average measurements as necessary.
2. Peak measurements: RBW = 1MHz, VBW = 1MHz, Sweep: Auto.
3. Average measurements: RBW = 1MHz, VBW = 10 Hz, Sweep: Auto.
4. “ \* ”, means this data is the worst emission level.
5. Measurement Level = Reading Level + Correct Factor.
6. The average measurement was not performed when the peak measured data under the limit of average detection.
7. The Emission above 18GHz were not included is because their levels are too low.

Site : CB4-H	Time : 2017/05/23
Limit : FCC_Part22/24_00M_00M_PK	Margin : 6
Probe : CB4-H_CE_Sub_B432_1-18GHz_3M_1116 - HORIZONTAL	Power : DC 24V
EUT : 3G Cellular Alarm Communicator	Note : Mode 5: WCDMA Band 5_Link_836.6MHz

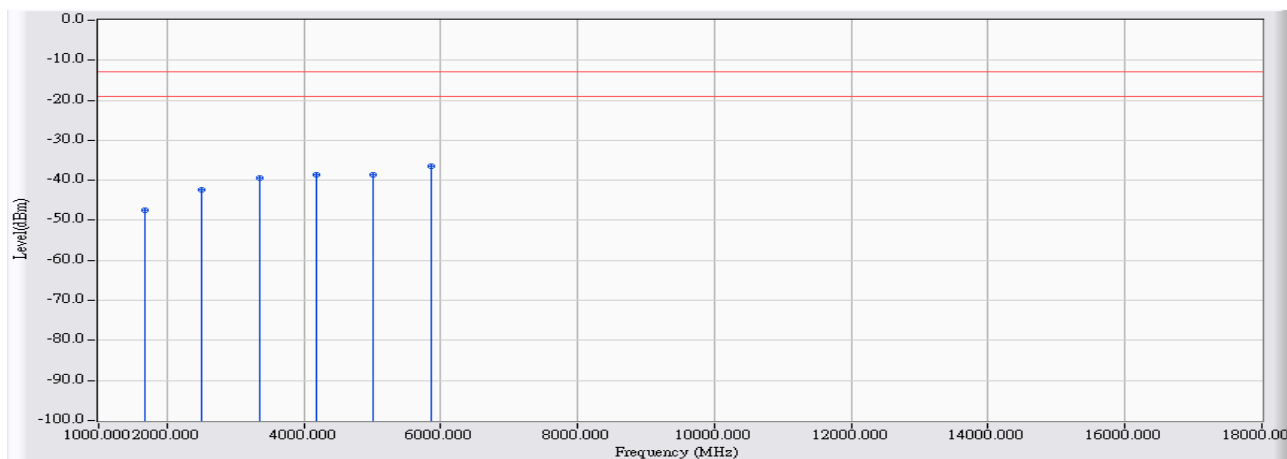

		Frequency (MHz)	Correct Factor (dB)	Reading Level (dBm)	Measure Level (dBm)	Margin (dB)	Limit (dBm)	Detector Type
1		1673.200	10.076	-57.510	-47.434	-34.434	-13.000	PEAK
2		2509.800	14.963	-57.390	-42.427	-29.427	-13.000	PEAK
3		3346.400	17.758	-57.230	-39.471	-26.471	-13.000	PEAK
4		4183.000	19.427	-57.930	-38.503	-25.503	-13.000	PEAK
5		5019.600	20.436	-58.910	-38.473	-25.473	-13.000	PEAK
6	*	5856.200	22.512	-58.940	-36.429	-23.429	-13.000	PEAK

Note:

1. All readings above 1GHz are performed with peak and/or average measurements as necessary.
2. Peak measurements: RBW = 1MHz, VBW = 1MHz, Sweep: Auto.
3. Average measurements: RBW = 1MHz, VBW = 10 Hz, Sweep: Auto.
4. “ \* ”, means this data is the worst emission level.
5. Measurement Level = Reading Level + Correct Factor.
6. The average measurement was not performed when the peak measured data under the limit of average detection.
7. The Emission above 18GHz were not included is because their levels are too low.

Site : CB4-H	Time : 2017/05/23
Limit : FCC_Part22/24_00M_00M_PK	Margin : 6
Probe : CB4-H_CE_Sub_B432_1-18GHz_3M_1116 - VERTICAL	Power : DC 24V
EUT : 3G Cellular Alarm Communicator	Note : Mode 5: WCDMA Band 5_Link_836.6MHz

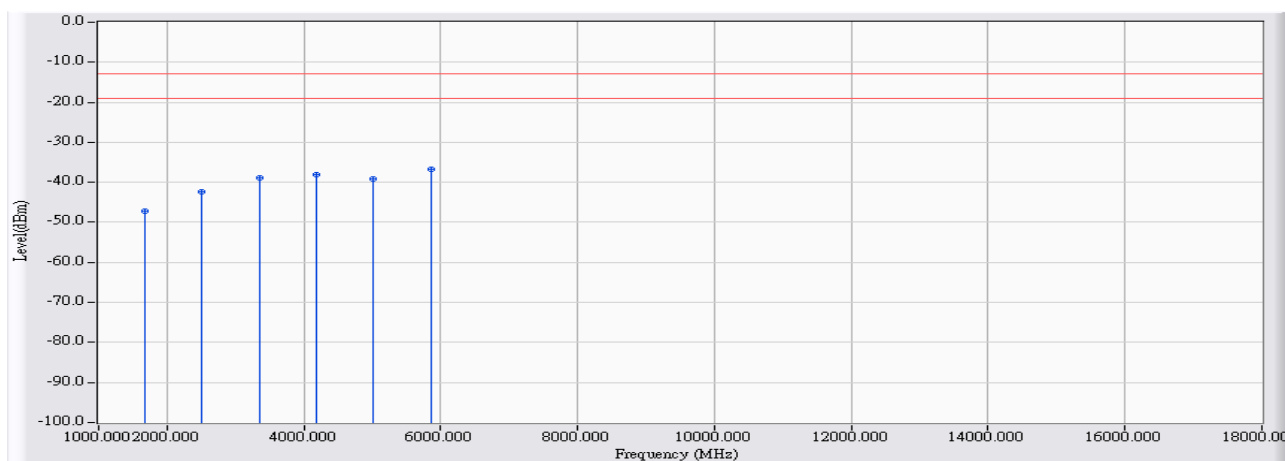

		Frequency (MHz)	Correct Factor (dB)	Reading Level (dBm)	Measure Level (dBm)	Margin (dB)	Limit (dBm)	Detector Type
1		1673.200	10.641	-57.860	-47.218	-34.218	-13.000	PEAK
2		2509.800	15.352	-57.810	-42.458	-29.458	-13.000	PEAK
3		3346.400	18.399	-57.300	-38.900	-25.900	-13.000	PEAK
4		4183.000	20.377	-58.480	-38.103	-25.103	-13.000	PEAK
5		5019.600	20.075	-59.160	-39.085	-26.085	-13.000	PEAK
6	*	5856.200	22.340	-59.060	-36.720	-23.720	-13.000	PEAK

Note:

1. All readings above 1GHz are performed with peak and/or average measurements as necessary.
2. Peak measurements: RBW = 1MHz, VBW = 1MHz, Sweep: Auto.
3. Average measurements: RBW = 1MHz, VBW = 10 Hz, Sweep: Auto.
4. “ \* ”, means this data is the worst emission level.
5. Measurement Level = Reading Level + Correct Factor.
6. The average measurement was not performed when the peak measured data under the limit of average detection.
7. The Emission above 18GHz were not included is because their levels are too low.

Site : CB4-H	Time : 2017/05/23
Limit : FCC_Part22/24_00M_00M_PK	Margin : 6
Probe : CB4-H_CE_Sub_B432_1-18GHz_3M_1116 - HORIZONTAL	Power : DC 24V
EUT : 3G Cellular Alarm Communicator	Note : Mode 5: WCDMA Band 5_Link_846.6MHz

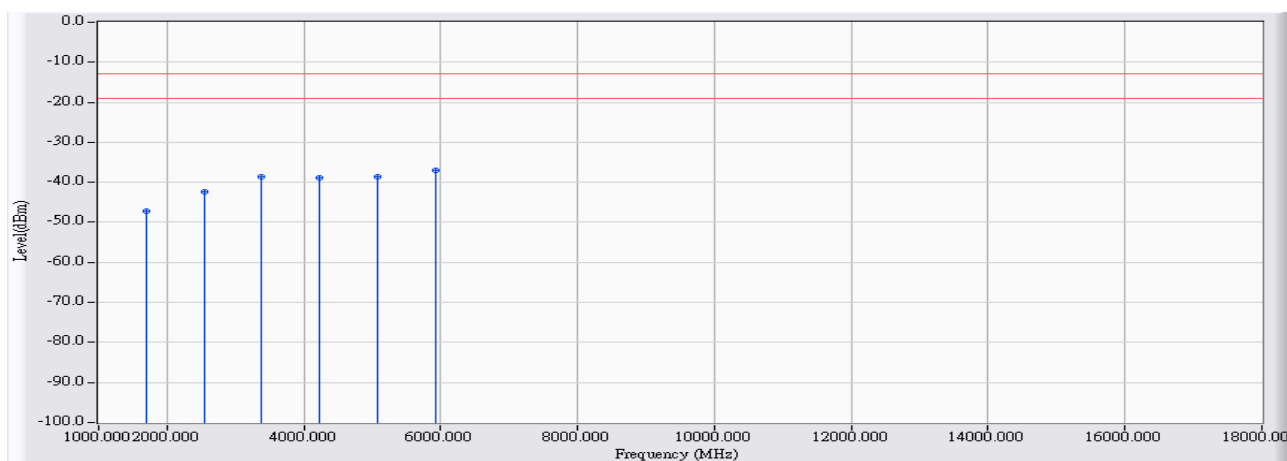

		Frequency (MHz)	Correct Factor (dB)	Reading Level (dBm)	Measure Level (dBm)	Margin (dB)	Limit (dBm)	Detector Type
1		1693.200	10.044	-57.320	-47.276	-34.276	-13.000	PEAK
2		2539.800	15.048	-57.390	-42.342	-29.342	-13.000	PEAK
3		3386.400	17.848	-56.390	-38.543	-25.543	-13.000	PEAK
4		4233.000	19.492	-58.450	-38.958	-25.958	-13.000	PEAK
5		5079.600	20.514	-59.050	-38.535	-25.535	-13.000	PEAK
6	*	5926.200	22.789	-59.780	-36.990	-23.990	-13.000	PEAK

Note:

1. All readings above 1GHz are performed with peak and/or average measurements as necessary.
2. Peak measurements: RBW = 1MHz, VBW = 1MHz, Sweep: Auto.
3. Average measurements: RBW = 1MHz, VBW = 10 Hz, Sweep: Auto.
4. “ \* ”, means this data is the worst emission level.
5. Measurement Level = Reading Level + Correct Factor.
6. The average measurement was not performed when the peak measured data under the limit of average detection.
7. The Emission above 18GHz were not included is because their levels are too low.

Site : CB4-H	Time : 2017/05/23
Limit : FCC_Part22/24_00M_00M_PK	Margin : 6
Probe : CB4-H_CE_Sub_B432_1-18GHz_3M_1116 - VERTICAL	Power : DC 24V
EUT : 3G Cellular Alarm Communicator	Note : Mode 5: WCDMA Band 5_Link_846.6MHz

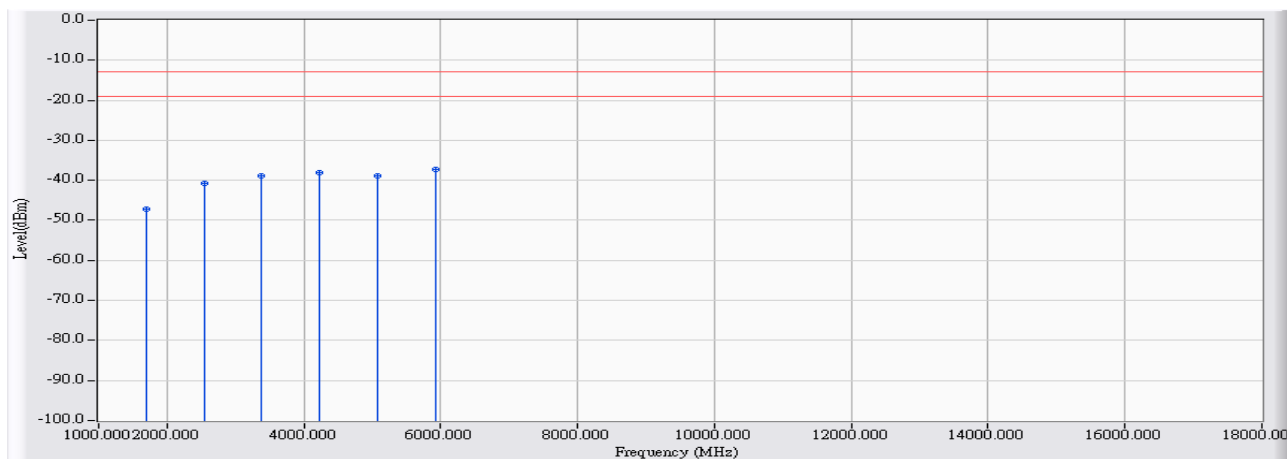

		Frequency (MHz)	Correct Factor (dB)	Reading Level (dBm)	Measure Level (dBm)	Margin (dB)	Limit (dBm)	Detector Type
1		1693.200	10.646	-57.960	-47.314	-34.314	-13.000	PEAK
2		2539.800	15.427	-56.220	-40.793	-27.793	-13.000	PEAK
3		3386.400	18.536	-57.520	-38.984	-25.984	-13.000	PEAK
4		4233.000	20.508	-58.660	-38.152	-25.152	-13.000	PEAK
5		5079.600	20.180	-59.030	-38.850	-25.850	-13.000	PEAK
6	*	5926.200	22.614	-59.930	-37.316	-24.316	-13.000	PEAK

Note:

1. All readings above 1GHz are performed with peak and/or average measurements as necessary.
2. Peak measurements: RBW = 1MHz, VBW = 1MHz, Sweep: Auto.
3. Average measurements: RBW = 1MHz, VBW = 10 Hz, Sweep: Auto.
4. “ \* ”, means this data is the worst emission level.
5. Measurement Level = Reading Level + Correct Factor.
6. The average measurement was not performed when the peak measured data under the limit of average detection.
7. The Emission above 18GHz were not included is because their levels are too low.



<b>Site : CB4-H</b>	<b>Time : 2017/05/23</b>
<b>Limit : FCC_Part22/24_00M_00M_PK</b>	<b>Margin : 6</b>
<b>Probe : CB4-H_CE_Sub_B432_1-18GHz_3M_1116 - HORIZONTAL</b>	<b>Power : DC 24V</b>
<b>EUT : 3G Cellular Alarm Communicator</b>	<b>Note : Mode 6: WCDMA Band 5_HSUPA_Link_826.4MHz</b>

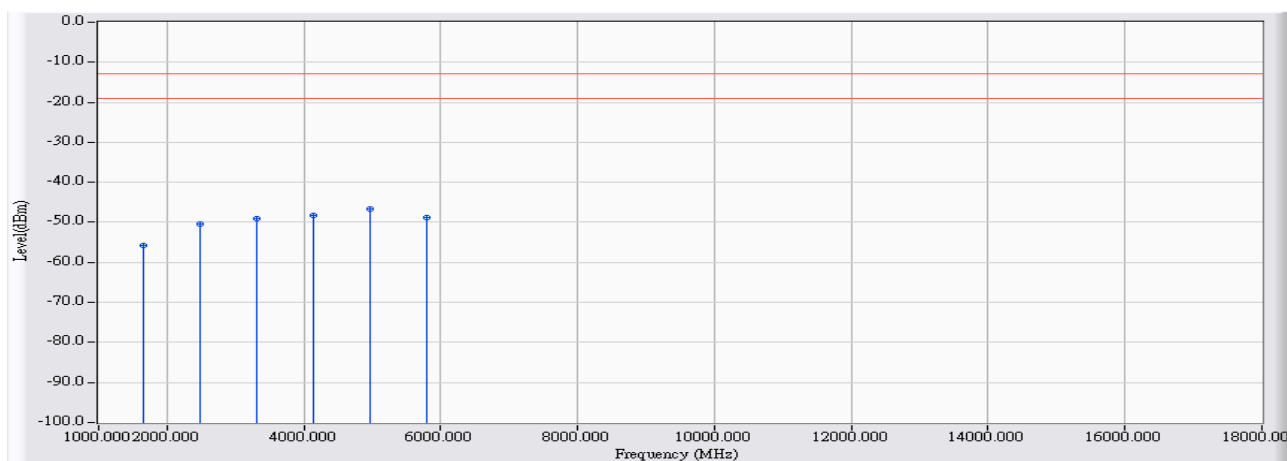

		<b>Frequency (MHz)</b>	<b>Correct Factor (dB)</b>	<b>Reading Level (dBm)</b>	<b>Measure Level (dBm)</b>	<b>Margin (dB)</b>	<b>Limit (dBm)</b>	<b>Detector Type</b>
1		1652.800	10.110	-65.830	-55.721	-42.721	-13.000	PEAK
2		2479.200	14.993	-65.370	-50.377	-37.377	-13.000	PEAK
3		3305.600	17.669	-66.680	-49.011	-36.011	-13.000	PEAK
4		4132.000	19.358	-67.650	-48.292	-35.292	-13.000	PEAK
5	*	4958.400	22.667	-69.240	-46.573	-33.573	-13.000	PEAK
6		5784.800	22.228	-71.000	-48.773	-35.773	-13.000	PEAK

**Note:**

1. All readings above 1GHz are performed with peak and/or average measurements as necessary.
2. Peak measurements: RBW = 1MHz, VBW = 1MHz, Sweep: Auto.
3. Average measurements: RBW = 1MHz, VBW = 10 Hz, Sweep: Auto.
4. “ \* ”, means this data is the worst emission level.
5. Measurement Level = Reading Level + Correct Factor.
6. The average measurement was not performed when the peak measured data under the limit of average detection.
7. The Emission above 18GHz were not included is because their levels are too low.

Site : CB4-H	Time : 2017/05/31
Limit : FCC_Part22/24_00M_00M_PK	Margin : 6
Probe : CB4-H_CE_Sub_B432_1-18GHz_3M_1116 - VERTICAL	Power : DC 24V
EUT : 3G Cellular Alarm Communicator	Note : Mode 6: WCDMA Band 5_HSUPA_Link_826.4MHz

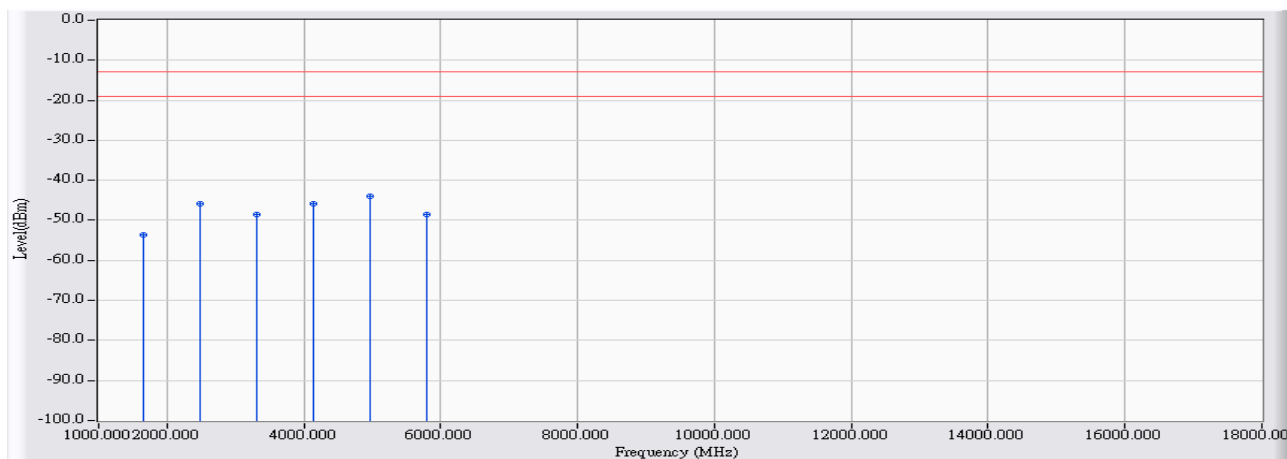

	Frequency (MHz)	Correct Factor (dB)	Reading Level (dBm)	Measure Level (dBm)	Margin (dB)	Limit (dBm)	Detector Type
1	1652.800	10.638	-64.180	-53.543	-40.543	-13.000	PEAK
2	2479.200	15.344	-61.120	-45.777	-32.777	-13.000	PEAK
3	3305.600	18.262	-66.680	-48.419	-35.419	-13.000	PEAK
4	4132.000	20.240	-66.190	-45.951	-32.951	-13.000	PEAK
5	* 4958.400	23.171	-67.140	-43.969	-30.969	-13.000	PEAK
6	5784.800	22.061	-70.640	-48.580	-35.580	-13.000	PEAK

Note:

1. All readings above 1GHz are performed with peak and/or average measurements as necessary.
2. Peak measurements: RBW = 1MHz, VBW = 1MHz, Sweep: Auto.
3. Average measurements: RBW = 1MHz, VBW = 10 Hz, Sweep: Auto.
4. “ \* ”, means this data is the worst emission level.
5. Measurement Level = Reading Level + Correct Factor.
6. The average measurement was not performed when the peak measured data under the limit of average detection.
7. The Emission above 18GHz were not included is because their levels are too low.

Site : CB4-H	Time : 2017/05/31
Limit : FCC_Part22/24_00M_00M_PK	Margin : 6
Probe : CB4-H_CE_Sub_B432_1-18GHz_3M_1116 - HORIZONTAL	Power : DC 24V
EUT : 3G Cellular Alarm Communicator	Note : Mode 6: WCDMA Band 5_HSUPA_Link_836.6MHz

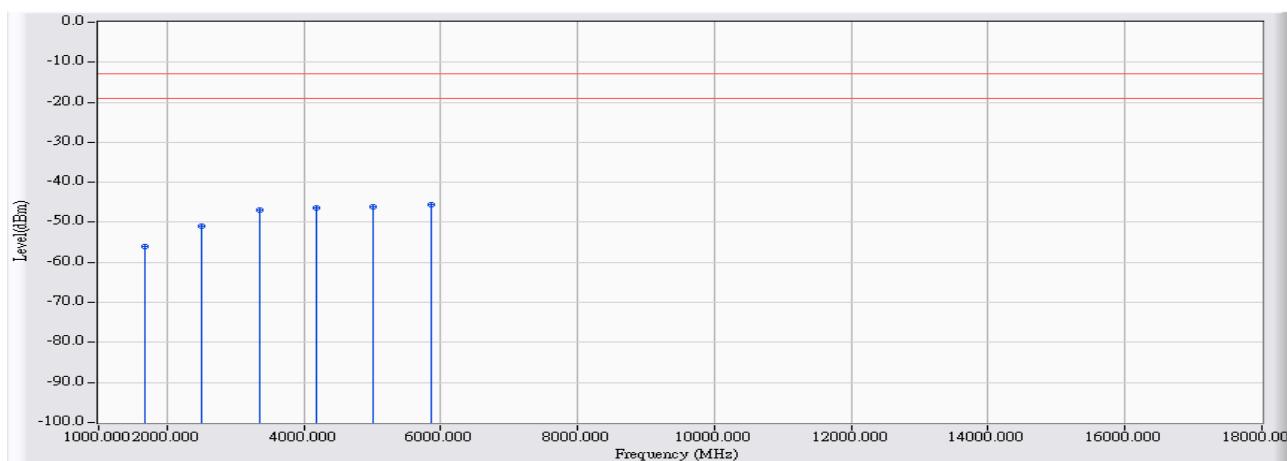

		Frequency (MHz)	Correct Factor (dB)	Reading Level (dBm)	Measure Level (dBm)	Margin (dB)	Limit (dBm)	Detector Type
1		1673.200	10.076	-66.130	-56.054	-43.054	-13.000	PEAK
2		2509.800	14.963	-65.970	-51.007	-38.007	-13.000	PEAK
3		3346.400	17.758	-64.660	-46.901	-33.901	-13.000	PEAK
4		4183.000	19.427	-65.760	-46.333	-33.333	-13.000	PEAK
5		5019.600	20.436	-66.500	-46.063	-33.063	-13.000	PEAK
6	*	5856.200	22.512	-68.040	-45.529	-32.529	-13.000	PEAK

Note:

1. All readings above 1GHz are performed with peak and/or average measurements as necessary.
2. Peak measurements: RBW = 1MHz, VBW = 1MHz, Sweep: Auto.
3. Average measurements: RBW = 1MHz, VBW = 10 Hz, Sweep: Auto.
4. “ \* ”, means this data is the worst emission level.
5. Measurement Level = Reading Level + Correct Factor.
6. The average measurement was not performed when the peak measured data under the limit of average detection.
7. The Emission above 18GHz were not included is because their levels are too low.

Site : CB4-H	Time : 2017/05/31
Limit : FCC_Part22/24_00M_00M_PK	Margin : 6
Probe : CB4-H_CE_Sub_B432_1-18GHz_3M_1116 - VERTICAL	Power : DC 24V
EUT : 3G Cellular Alarm Communicator	Note : Mode 6: WCDMA Band 5_HSUPA_Link_836.6MHz

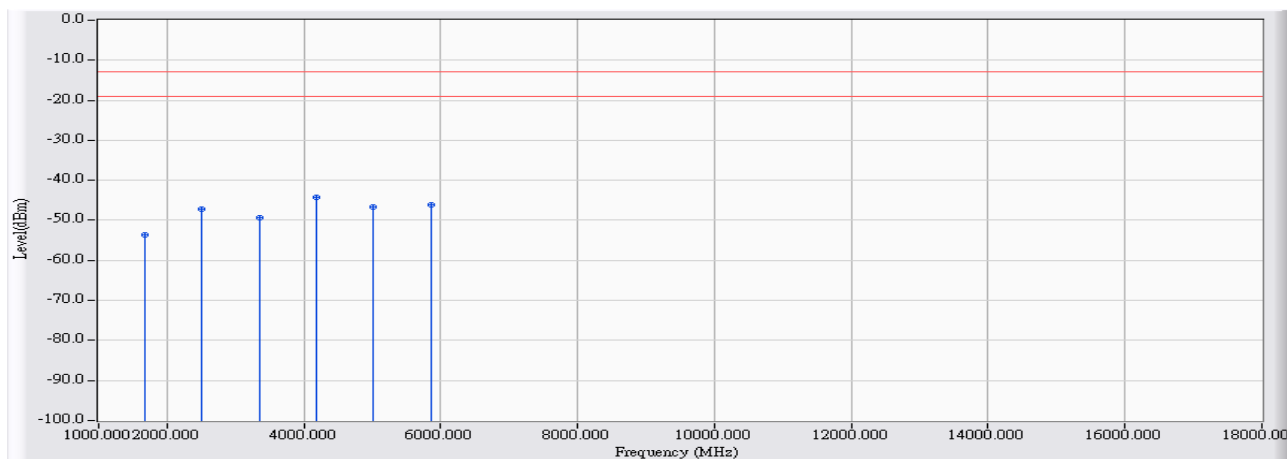

	Frequency (MHz)	Correct Factor (dB)	Reading Level (dBm)	Measure Level (dBm)	Margin (dB)	Limit (dBm)	Detector Type
1	1673.200	10.641	-64.220	-53.578	-40.578	-13.000	PEAK
2	2509.800	15.352	-62.460	-47.108	-34.108	-13.000	PEAK
3	3346.400	18.399	-67.760	-49.360	-36.360	-13.000	PEAK
4	* 4183.000	20.377	-64.700	-44.323	-31.323	-13.000	PEAK
5	5019.600	20.075	-66.720	-46.645	-33.645	-13.000	PEAK
6	5856.200	22.340	-68.340	-46.000	-33.000	-13.000	PEAK

Note:

1. All readings above 1GHz are performed with peak and/or average measurements as necessary.
2. Peak measurements: RBW = 1MHz, VBW = 1MHz, Sweep: Auto.
3. Average measurements: RBW = 1MHz, VBW = 10 Hz, Sweep: Auto.
4. “ \* ”, means this data is the worst emission level.
5. Measurement Level = Reading Level + Correct Factor.
6. The average measurement was not performed when the peak measured data under the limit of average detection.
7. The Emission above 18GHz were not included is because their levels are too low.

Site : CB4-H	Time : 2017/05/31
Limit : FCC_Part22/24_00M_00M_PK	Margin : 6
Probe : CB4-H_CE_Sub_B432_1-18GHz_3M_1116 - HORIZONTAL	Power : DC 24V
EUT : 3G Cellular Alarm Communicator	Note : Mode 6: WCDMA Band 5_HSUPA_Link_846.6MHz

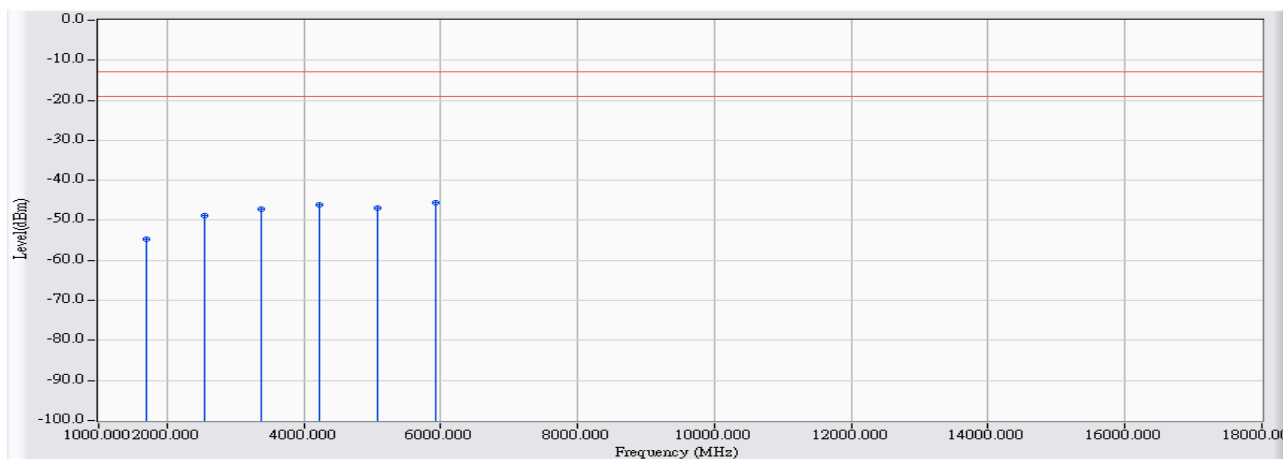

		Frequency (MHz)	Correct Factor (dB)	Reading Level (dBm)	Measure Level (dBm)	Margin (dB)	Limit (dBm)	Detector Type
1		1693.200	10.044	-64.620	-54.576	-41.576	-13.000	PEAK
2		2539.800	15.048	-63.880	-48.832	-35.832	-13.000	PEAK
3		3386.400	17.848	-65.070	-47.223	-34.223	-13.000	PEAK
4		4233.000	19.492	-65.510	-46.018	-33.018	-13.000	PEAK
5		5079.600	20.514	-67.370	-46.855	-33.855	-13.000	PEAK
6	*	5926.200	22.789	-68.390	-45.600	-32.600	-13.000	PEAK

Note:

1. All readings above 1GHz are performed with peak and/or average measurements as necessary.
2. Peak measurements: RBW = 1MHz, VBW = 1MHz, Sweep: Auto.
3. Average measurements: RBW = 1MHz, VBW = 10 Hz, Sweep: Auto.
4. “ \* ”, means this data is the worst emission level.
5. Measurement Level = Reading Level + Correct Factor.
6. The average measurement was not performed when the peak measured data under the limit of average detection.
7. The Emission above 18GHz were not included is because their levels are too low.

Site : CB4-H	Time : 2017/05/31
Limit : FCC_Part22/24_00M_00M_PK	Margin : 6
Probe : CB4-H_CE_Sub_B432_1-18GHz_3M_1116 - VERTICAL	Power : DC 24V
EUT : 3G Cellular Alarm Communicator	Note : Mode 6: WCDMA Band 5_HSUPA_Link_846.6MHz

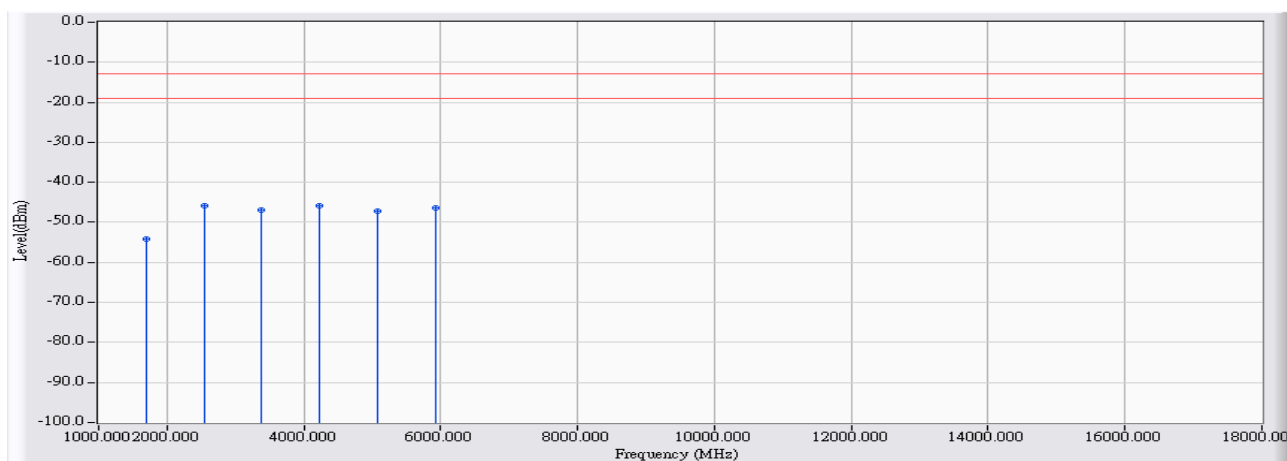

	Frequency (MHz)	Correct Factor (dB)	Reading Level (dBm)	Measure Level (dBm)	Margin (dB)	Limit (dBm)	Detector Type
1	1693.200	10.646	-64.780	-54.134	-41.134	-13.000	PEAK
2	2539.800	15.427	-61.330	-45.903	-32.903	-13.000	PEAK
3	3386.400	18.536	-65.420	-46.884	-33.884	-13.000	PEAK
4	* 4233.000	20.508	-66.240	-45.732	-32.732	-13.000	PEAK
5	5079.600	20.180	-67.420	-47.240	-34.240	-13.000	PEAK
6	5926.200	22.614	-69.040	-46.426	-33.426	-13.000	PEAK

Note:

1. All readings above 1GHz are performed with peak and/or average measurements as necessary.
2. Peak measurements: RBW = 1MHz, VBW = 1MHz, Sweep: Auto.
3. Average measurements: RBW = 1MHz, VBW = 10 Hz, Sweep: Auto.
4. “ \* ”, means this data is the worst emission level.
5. Measurement Level = Reading Level + Correct Factor.
6. The average measurement was not performed when the peak measured data under the limit of average detection.
7. The Emission above 18GHz were not included is because their levels are too low.

Site : CB4-H	Time : 2017/05/31
Limit : FCC_Part22/24_00M_00M_PK	Margin : 6
Probe : CB4-H_CE_Sub_B432_1-18GHz_3M_1116 - HORIZONTAL	Power : DC 24V
EUT : 3G Cellular Alarm Communicator	Note : Mode 7: WCDMA Band 5_HSDPA_Link_826.4MHz

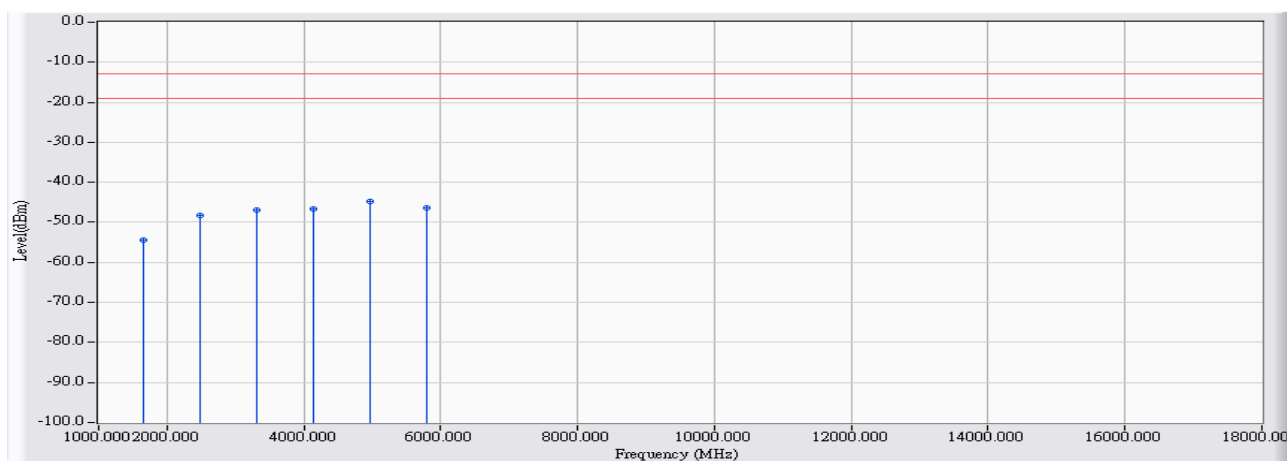

	Frequency (MHz)	Correct Factor (dB)	Reading Level (dBm)	Measure Level (dBm)	Margin (dB)	Limit (dBm)	Detector Type
1	1652.800	10.110	-64.610	-54.501	-41.501	-13.000	PEAK
2	2479.200	14.993	-63.340	-48.347	-35.347	-13.000	PEAK
3	3305.600	17.669	-64.480	-46.811	-33.811	-13.000	PEAK
4	4132.000	19.358	-66.010	-46.652	-33.652	-13.000	PEAK
5	* 4958.400	22.667	-67.320	-44.653	-31.653	-13.000	PEAK
6	5784.800	22.228	-68.600	-46.373	-33.373	-13.000	PEAK

Note:

1. All readings above 1GHz are performed with peak and/or average measurements as necessary.
2. Peak measurements: RBW = 1MHz, VBW = 1MHz, Sweep: Auto.
3. Average measurements: RBW = 1MHz, VBW = 10 Hz, Sweep: Auto.
4. “ \* ”, means this data is the worst emission level.
5. Measurement Level = Reading Level + Correct Factor.
6. The average measurement was not performed when the peak measured data under the limit of average detection.
7. The Emission above 18GHz were not included is because their levels are too low.

Site : CB4-H	Time : 2017/05/31
Limit : FCC_Part22/24_00M_00M_PK	Margin : 6
Probe : CB4-H_CE_Sub_B432_1-18GHz_3M_1116 - VERTICAL	Power : DC 24V
EUT : 3G Cellular Alarm Communicator	Note : Mode 7: WCDMA Band 5_HSDPA_Link_826.4MHz

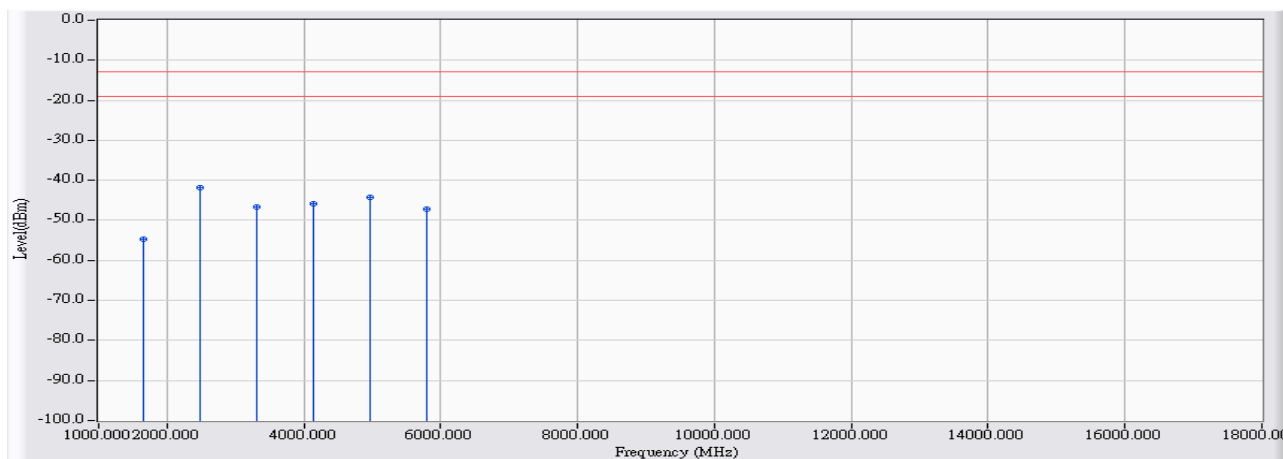

		Frequency (MHz)	Correct Factor (dB)	Reading Level (dBm)	Measure Level (dBm)	Margin (dB)	Limit (dBm)	Detector Type
1		1652.800	10.638	-65.360	-54.723	-41.723	-13.000	PEAK
2	*	2479.200	15.344	-57.240	-41.897	-28.897	-13.000	PEAK
3		3305.600	18.262	-65.010	-46.749	-33.749	-13.000	PEAK
4		4132.000	20.240	-66.120	-45.881	-32.881	-13.000	PEAK
5		4958.400	23.171	-67.280	-44.109	-31.109	-13.000	PEAK
6		5784.800	22.061	-69.270	-47.210	-34.210	-13.000	PEAK

Note:

1. All readings above 1GHz are performed with peak and/or average measurements as necessary.
2. Peak measurements: RBW = 1MHz, VBW = 1MHz, Sweep: Auto.
3. Average measurements: RBW = 1MHz, VBW = 10 Hz, Sweep: Auto.
4. “ \* ”, means this data is the worst emission level.
5. Measurement Level = Reading Level + Correct Factor.
6. The average measurement was not performed when the peak measured data under the limit of average detection.
7. The Emission above 18GHz were not included is because their levels are too low.



<b>Site : CB4-H</b>	<b>Time : 2017/05/31</b>
<b>Limit : FCC_Part22/24_00M_00M_PK</b>	<b>Margin : 6</b>
<b>Probe : CB4-H_CE_Sub_B432_1-18GHz_3M_1116 - HORIZONTAL</b>	<b>Power : DC 24V</b>
<b>EUT : 3G Cellular Alarm Communicator</b>	<b>Note : Mode 7: WCDMA Band 5_HSDPA_Link_836.6MHz</b>

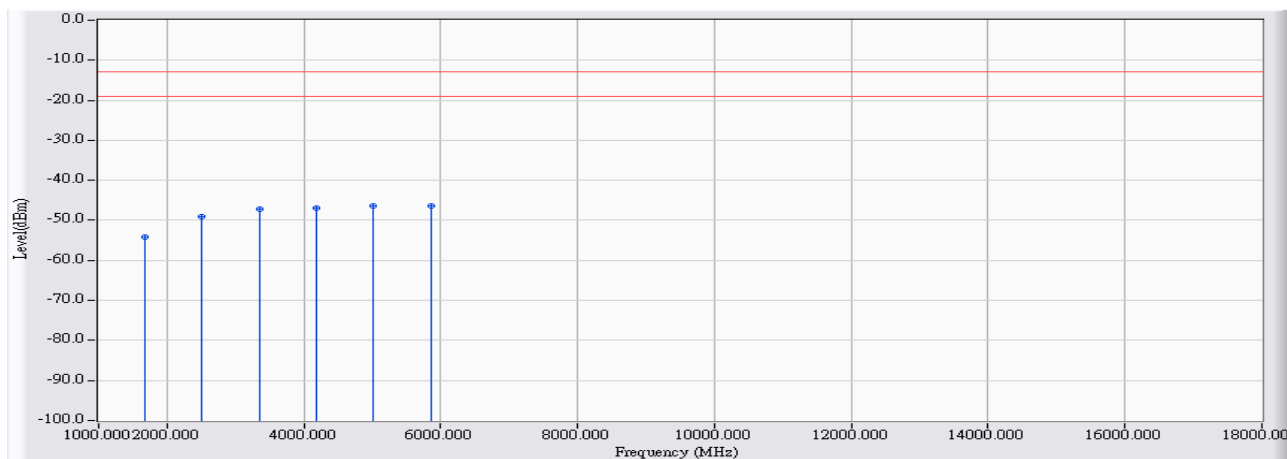

		<b>Frequency (MHz)</b>	<b>Correct Factor (dB)</b>	<b>Reading Level (dBm)</b>	<b>Measure Level (dBm)</b>	<b>Margin (dB)</b>	<b>Limit (dBm)</b>	<b>Detector Type</b>
1		1673.200	10.076	-64.350	-54.274	-41.274	-13.000	PEAK
2		2509.800	14.963	-63.940	-48.977	-35.977	-13.000	PEAK
3		3346.400	17.758	-64.920	-47.161	-34.161	-13.000	PEAK
4		4183.000	19.427	-66.450	-47.023	-34.023	-13.000	PEAK
5	*	5019.600	20.436	-66.790	-46.353	-33.353	-13.000	PEAK
6		5856.200	22.512	-68.900	-46.389	-33.389	-13.000	PEAK

**Note:**

1. All readings above 1GHz are performed with peak and/or average measurements as necessary.
2. Peak measurements: RBW = 1MHz, VBW = 1MHz, Sweep: Auto.
3. Average measurements: RBW = 1MHz, VBW = 10 Hz, Sweep: Auto.
4. “ \* ”, means this data is the worst emission level.
5. Measurement Level = Reading Level + Correct Factor.
6. The average measurement was not performed when the peak measured data under the limit of average detection.
7. The Emission above 18GHz were not included is because their levels are too low.

Site : CB4-H	Time : 2017/05/31
Limit : FCC_Part22/24_00M_00M_PK	Margin : 6
Probe : CB4-H_CE_Sub_B432_1-18GHz_3M_1116 - VERTICAL	Power : DC 24V
EUT : 3G Cellular Alarm Communicator	Note : Mode 7: WCDMA Band 5_HSDPA_Link_836.6MHz

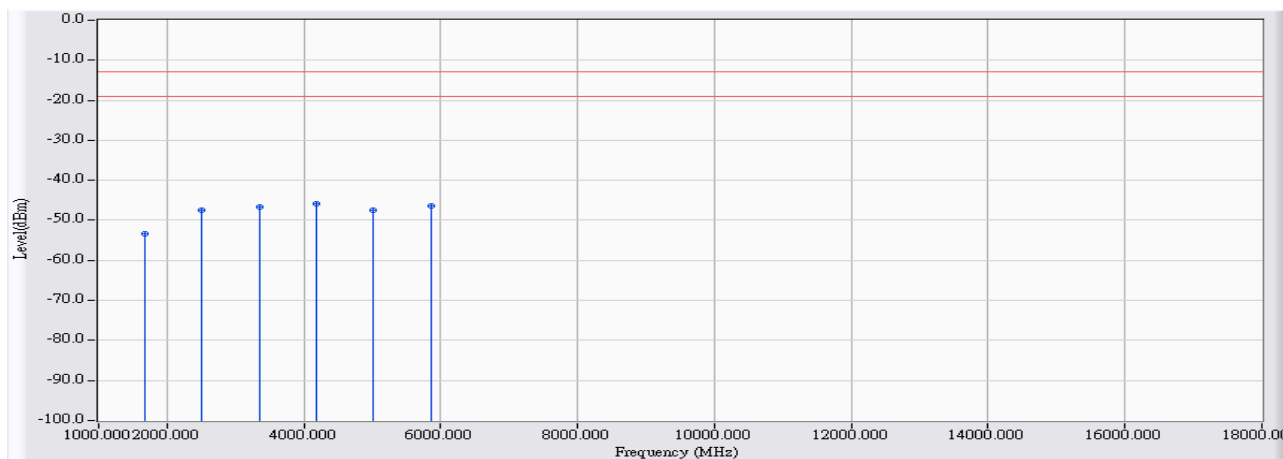

	Frequency (MHz)	Correct Factor (dB)	Reading Level (dBm)	Measure Level (dBm)	Margin (dB)	Limit (dBm)	Detector Type
1	1673.200	10.641	-64.050	-53.408	-40.408	-13.000	PEAK
2	2509.800	15.352	-62.780	-47.428	-34.428	-13.000	PEAK
3	3346.400	18.399	-64.930	-46.530	-33.530	-13.000	PEAK
4	* 4183.000	20.377	-66.220	-45.843	-32.843	-13.000	PEAK
5	5019.600	20.075	-67.490	-47.415	-34.415	-13.000	PEAK
6	5856.200	22.340	-68.610	-46.270	-33.270	-13.000	PEAK

Note:

1. All readings above 1GHz are performed with peak and/or average measurements as necessary.
2. Peak measurements: RBW = 1MHz, VBW = 1MHz, Sweep: Auto.
3. Average measurements: RBW = 1MHz, VBW = 10 Hz, Sweep: Auto.
4. “ \* ”, means this data is the worst emission level.
5. Measurement Level = Reading Level + Correct Factor.
6. The average measurement was not performed when the peak measured data under the limit of average detection.
7. The Emission above 18GHz were not included is because their levels are too low.

Site : CB4-H	Time : 2017/05/31
Limit : FCC_Part22/24_00M_00M_PK	Margin : 6
Probe : CB4-H_CE_Sub_B432_1-18GHz_3M_1116 - HORIZONTAL	Power : DC 24V
EUT : 3G Cellular Alarm Communicator	Note : Mode 7: WCDMA Band 5_HSDPA_Link_846.6MHz

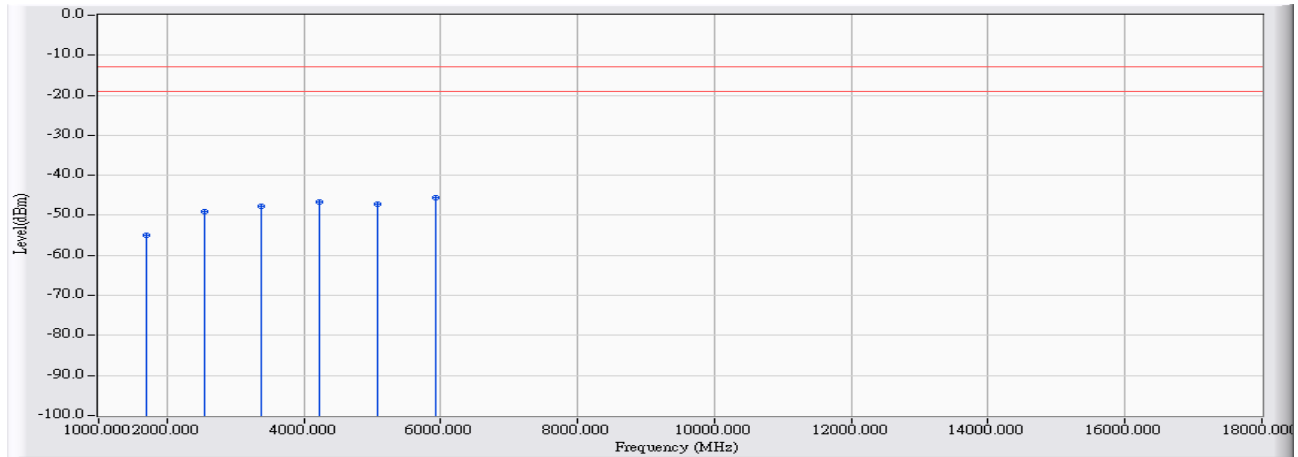

		Frequency (MHz)	Correct Factor (dB)	Reading Level (dBm)	Measure Level (dBm)	Margin (dB)	Limit (dBm)	Detector Type
1		1693.200	10.044	-64.880	-54.836	-41.836	-13.000	PEAK
2		2539.800	15.048	-64.000	-48.952	-35.952	-13.000	PEAK
3		3386.400	17.848	-65.670	-47.823	-34.823	-13.000	PEAK
4		4233.000	19.492	-66.170	-46.678	-33.678	-13.000	PEAK
5		5079.600	20.514	-67.770	-47.255	-34.255	-13.000	PEAK
6	*	5926.200	22.789	-68.360	-45.570	-32.570	-13.000	PEAK

Note:

1. All readings above 1GHz are performed with peak and/or average measurements as necessary.
2. Peak measurements: RBW = 1MHz, VBW = 1MHz, Sweep: Auto.
3. Average measurements: RBW = 1MHz, VBW = 10 Hz, Sweep: Auto.
4. “ \* ”, means this data is the worst emission level.
5. Measurement Level = Reading Level + Correct Factor.
6. The average measurement was not performed when the peak measured data under the limit of average detection.
7. The Emission above 18GHz were not included is because their levels are too low.

Site : CB4-H	Time : 2017/05/31
Limit : FCC_Part22/24_00M_00M_PK	Margin : 6
Probe : CB4-H_CE_Sub_B432_1-18GHz_3M_1116 - VERTICAL	Power : DC 24V
EUT : 3G Cellular Alarm Communicator	Note : Mode 7: WCDMA Band 5_HSDPA_Link_846.6MHz

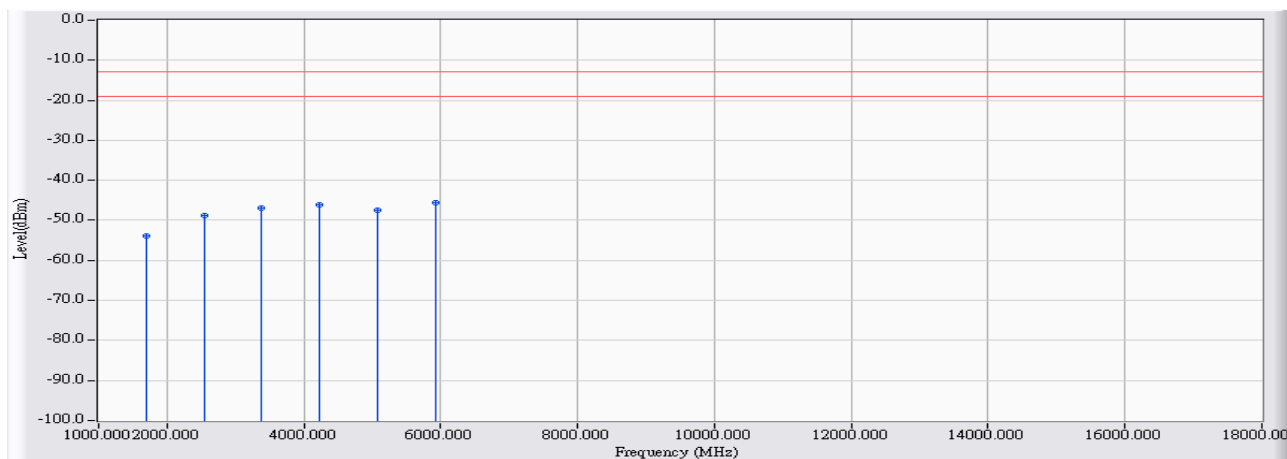

		Frequency (MHz)	Correct Factor (dB)	Reading Level (dBm)	Measure Level (dBm)	Margin (dB)	Limit (dBm)	Detector Type
1		1693.200	10.646	-64.530	-53.884	-40.884	-13.000	PEAK
2		2539.800	15.427	-64.310	-48.883	-35.883	-13.000	PEAK
3		3386.400	18.536	-65.550	-47.014	-34.014	-13.000	PEAK
4		4233.000	20.508	-66.560	-46.052	-33.052	-13.000	PEAK
5		5079.600	20.180	-67.700	-47.520	-34.520	-13.000	PEAK
6	*	5926.200	22.614	-68.160	-45.546	-32.546	-13.000	PEAK

Note:

1. All readings above 1GHz are performed with peak and/or average measurements as necessary.
2. Peak measurements: RBW = 1MHz, VBW = 1MHz, Sweep: Auto.
3. Average measurements: RBW = 1MHz, VBW = 10 Hz, Sweep: Auto.
4. “ \* ”, means this data is the worst emission level.
5. Measurement Level = Reading Level + Correct Factor.
6. The average measurement was not performed when the peak measured data under the limit of average detection.
7. The Emission above 18GHz were not included is because their levels are too low.

Site : CB4-H	Time : 2017/05/23
Limit : FCC_Part22/24_00M_00M_PK	Margin : 6
Probe : CB4-H_CE_Sub_B432_1-18GHz_3M_1116 - HORIZONTAL	Power : DC 24V
EUT : 3G Cellular Alarm Communicator	Note : Mode 8: WCDMA Band 2_Link_1852.4MHz

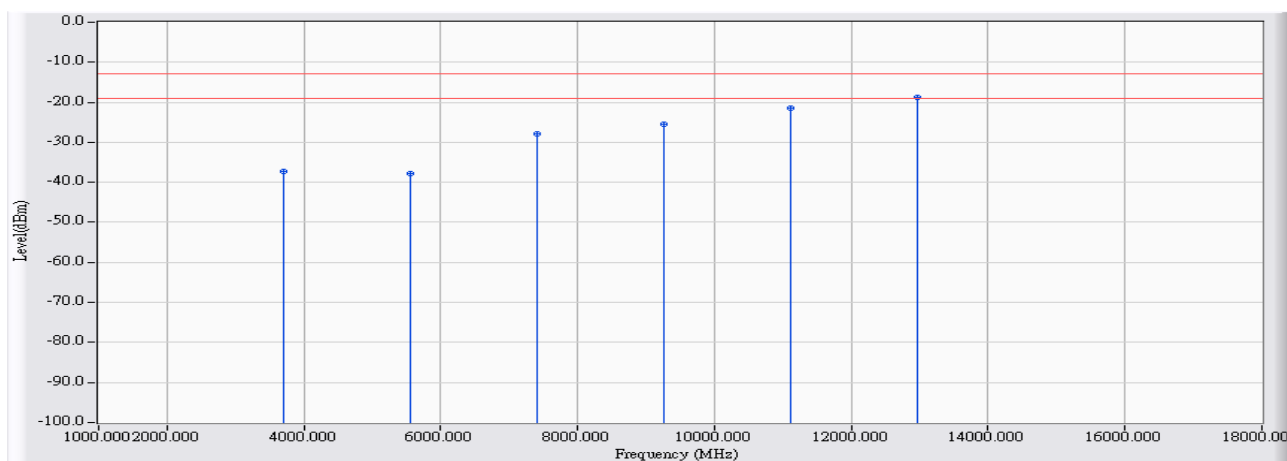

		Frequency (MHz)	Correct Factor (dB)	Reading Level (dBm)	Measure Level (dBm)	Margin (dB)	Limit (dBm)	Detector Type
1		3704.800	18.657	-55.870	-37.213	-24.213	-13.000	PEAK
2		5557.200	21.266	-59.200	-37.934	-24.934	-13.000	PEAK
3		7409.600	28.781	-56.560	-27.779	-14.779	-13.000	PEAK
4		9262.000	33.016	-58.400	-25.385	-12.385	-13.000	PEAK
5		11114.400	36.234	-57.660	-21.425	-8.425	-13.000	PEAK
6	*	12966.800	38.618	-57.420	-18.802	-5.802	-13.000	PEAK

Note:

1. All readings above 1GHz are performed with peak and/or average measurements as necessary.
2. Peak measurements: RBW = 1MHz, VBW = 1MHz, Sweep: Auto.
3. Average measurements: RBW = 1MHz, VBW = 10 Hz, Sweep: Auto.
4. “ \* ”, means this data is the worst emission level.
5. Measurement Level = Reading Level + Correct Factor.
6. The average measurement was not performed when the peak measured data under the limit of average detection.
7. The Emission above 18GHz were not included is because their levels are too low.

Site : CB4-H	Time : 2017/05/23
Limit : FCC_Part22/24_00M_00M_PK	Margin : 6
Probe : CB4-H_CE_Sub_B432_1-18GHz_3M_1116 - VERTICAL	Power : DC 24V
EUT : 3G Cellular Alarm Communicator	Note : Mode 8: WCDMA Band 2_Link_1852.4MHz

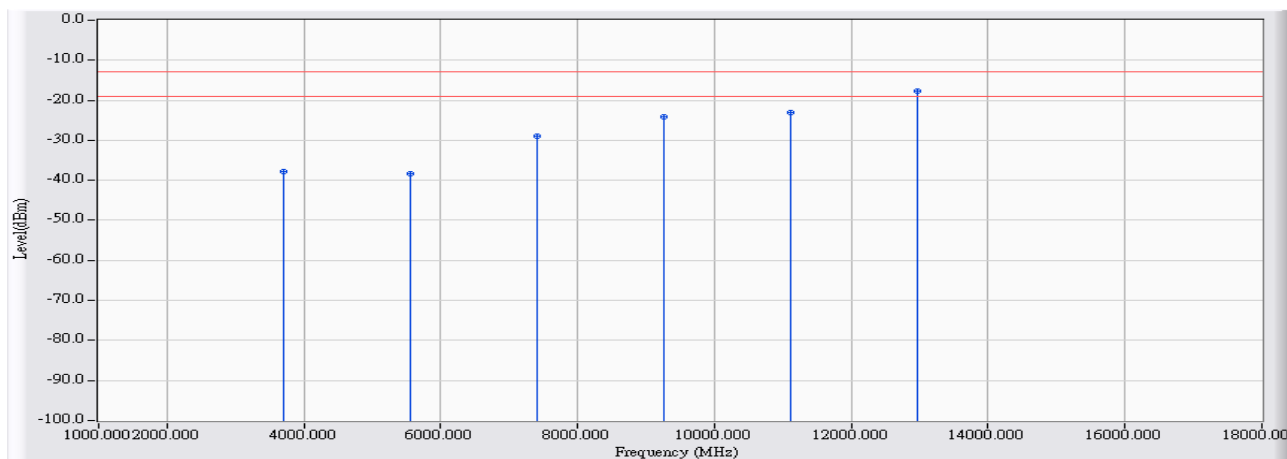

		Frequency (MHz)	Correct Factor (dB)	Reading Level (dBm)	Measure Level (dBm)	Margin (dB)	Limit (dBm)	Detector Type
1		3704.800	19.458	-57.200	-37.742	-24.742	-13.000	PEAK
2		5557.200	21.112	-59.410	-38.298	-25.298	-13.000	PEAK
3		7409.600	28.595	-57.570	-28.975	-15.975	-13.000	PEAK
4		9262.000	34.287	-58.290	-24.004	-11.004	-13.000	PEAK
5		11114.400	35.145	-58.260	-23.115	-10.115	-13.000	PEAK
6	*	12966.800	39.804	-57.410	-17.605	-4.605	-13.000	PEAK

Note:

1. All readings above 1GHz are performed with peak and/or average measurements as necessary.
2. Peak measurements: RBW = 1MHz, VBW = 1MHz, Sweep: Auto.
3. Average measurements: RBW = 1MHz, VBW = 10 Hz, Sweep: Auto.
4. “ \* ”, means this data is the worst emission level.
5. Measurement Level = Reading Level + Correct Factor.
6. The average measurement was not performed when the peak measured data under the limit of average detection.
7. The Emission above 18GHz were not included is because their levels are too low.

Site : CB4-H	Time : 2017/05/23
Limit : FCC_Part22/24_00M_00M_PK	Margin : 6
Probe : CB4-H_CE_Sub_B432_1-18GHz_3M_1116 - HORIZONTAL	Power : DC 24V
EUT : 3G Cellular Alarm Communicator	Note : Mode 8: WCDMA Band 2_Link_1880MHz

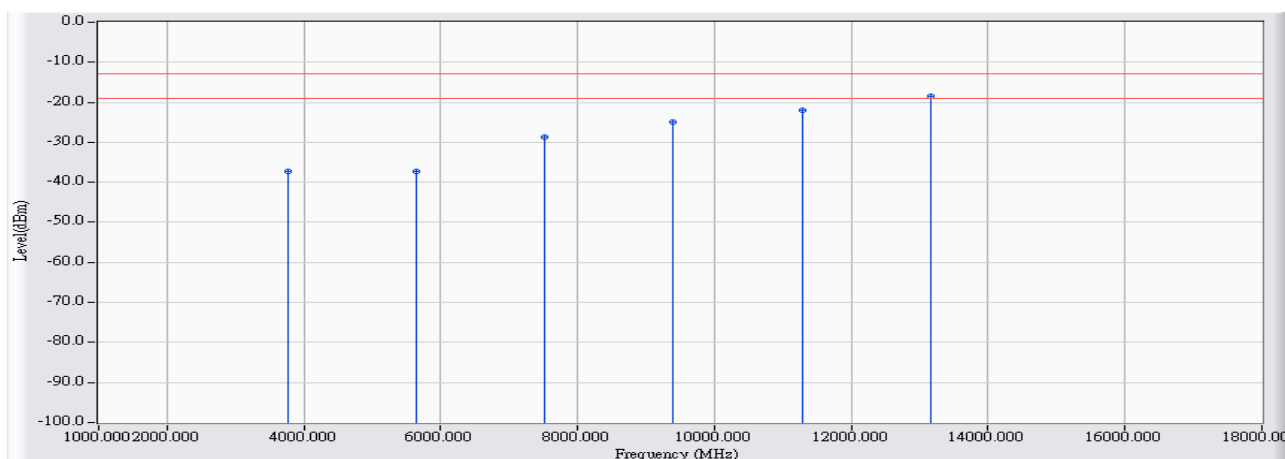

		Frequency (MHz)	Correct Factor (dB)	Reading Level (dBm)	Measure Level (dBm)	Margin (dB)	Limit (dBm)	Detector Type
1		3760.000	18.797	-56.040	-37.244	-24.244	-13.000	PEAK
2		5640.000	21.619	-58.820	-37.201	-24.201	-13.000	PEAK
3		7520.000	28.931	-57.690	-28.759	-15.759	-13.000	PEAK
4		9400.000	33.161	-58.040	-24.878	-11.878	-13.000	PEAK
5		11280.000	36.329	-58.310	-21.981	-8.981	-13.000	PEAK
6	*	13160.000	38.672	-57.100	-18.428	-5.428	-13.000	PEAK

Note:

1. All readings above 1GHz are performed with peak and/or average measurements as necessary.
2. Peak measurements: RBW = 1MHz, VBW = 1MHz, Sweep: Auto.
3. Average measurements: RBW = 1MHz, VBW = 10 Hz, Sweep: Auto.
4. “ \* ”, means this data is the worst emission level.
5. Measurement Level = Reading Level + Correct Factor.
6. The average measurement was not performed when the peak measured data under the limit of average detection.
7. The Emission above 18GHz were not included is because their levels are too low.

Site : CB4-H	Time : 2017/05/23
Limit : FCC_Part22/24_00M_00M_PK	Margin : 6
Probe : CB4-H_CE_Sub_B432_1-18GHz_3M_1116 - VERTICAL	Power : DC 24V
EUT : 3G Cellular Alarm Communicator	Note : Mode 8: WCDMA Band 2_Link_1880MHz

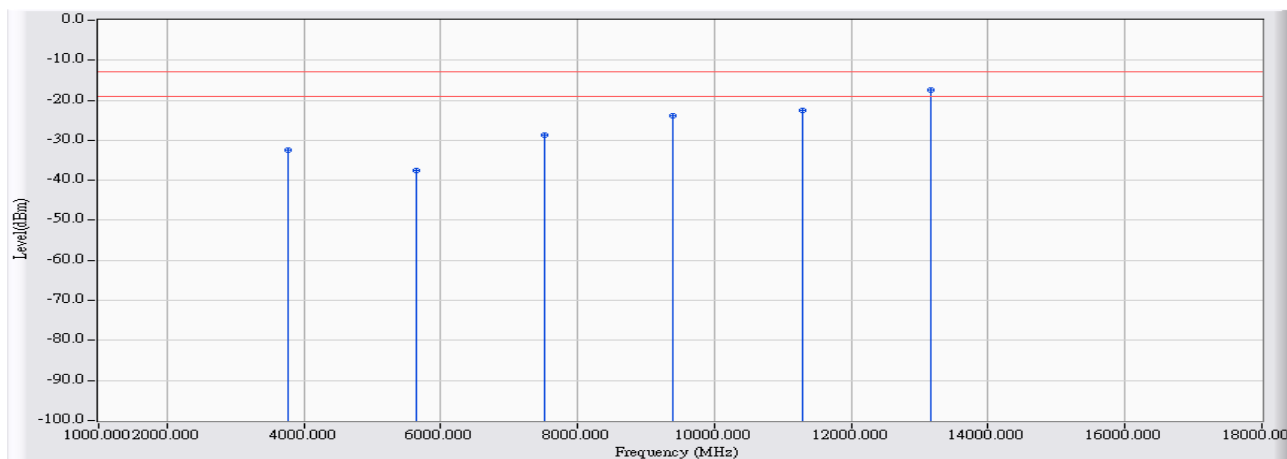

		Frequency (MHz)	Correct Factor (dB)	Reading Level (dBm)	Measure Level (dBm)	Margin (dB)	Limit (dBm)	Detector Type
1		3760.000	19.589	-52.080	-32.491	-19.491	-13.000	PEAK
2		5640.000	21.461	-58.890	-37.429	-24.429	-13.000	PEAK
3		7520.000	29.017	-57.730	-28.714	-15.714	-13.000	PEAK
4		9400.000	34.623	-58.590	-23.966	-10.966	-13.000	PEAK
5		11280.000	35.703	-58.130	-22.427	-9.427	-13.000	PEAK
6	*	13160.000	39.992	-57.430	-17.438	-4.438	-13.000	PEAK

Note:

1. All readings above 1GHz are performed with peak and/or average measurements as necessary.
2. Peak measurements: RBW = 1MHz, VBW = 1MHz, Sweep: Auto.
3. Average measurements: RBW = 1MHz, VBW = 10 Hz, Sweep: Auto.
4. “ \* ”, means this data is the worst emission level.
5. Measurement Level = Reading Level + Correct Factor.
6. The average measurement was not performed when the peak measured data under the limit of average detection.
7. The Emission above 18GHz were not included is because their levels are too low.



Site : CB4-H	Time : 2017/05/23
Limit : FCC_Part22/24_00M_00M_PK	Margin : 6
Probe : CB4-H_CE_Sub_B432_1-18GHz_3M_1116 - HORIZONTAL	Power : DC 24V
EUT : 3G Cellular Alarm Communicator	Note : Mode 8: WCDMA Band 2_Link_1907.6MHz

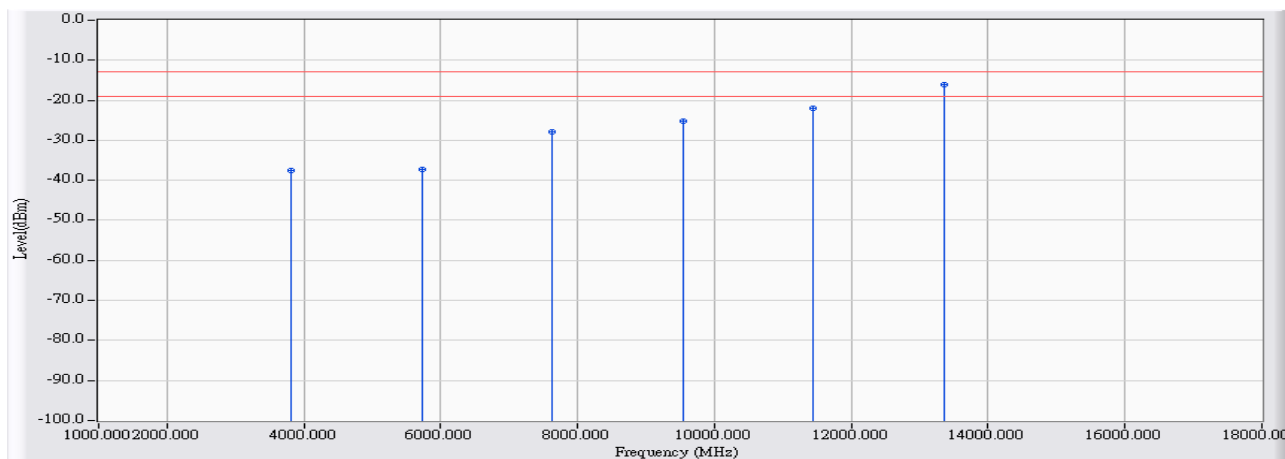

		Frequency (MHz)	Correct Factor (dB)	Reading Level (dBm)	Measure Level (dBm)	Margin (dB)	Limit (dBm)	Detector Type
1		3815.200	18.884	-56.410	-37.526	-24.526	-13.000	PEAK
2		5722.800	21.972	-59.200	-37.227	-24.227	-13.000	PEAK
3		7630.400	29.366	-57.260	-27.893	-14.893	-13.000	PEAK
4		9538.000	33.377	-58.520	-25.142	-12.142	-13.000	PEAK
5		11445.600	36.375	-58.380	-22.006	-9.006	-13.000	PEAK
6	*	13353.200	38.844	-54.940	-16.095	-3.095	-13.000	PEAK

Note:

1. All readings above 1GHz are performed with peak and/or average measurements as necessary.
2. Peak measurements: RBW = 1MHz, VBW = 1MHz, Sweep: Auto.
3. Average measurements: RBW = 1MHz, VBW = 10 Hz, Sweep: Auto.
4. “ \* ”, means this data is the worst emission level.
5. Measurement Level = Reading Level + Correct Factor.
6. The average measurement was not performed when the peak measured data under the limit of average detection.
7. The Emission above 18GHz were not included is because their levels are too low.

Site : CB4-H	Time : 2017/05/23
Limit : FCC_Part22/24_00M_00M_PK	Margin : 6
Probe : CB4-H_CE_Sub_B432_1-18GHz_3M_1116 - VERTICAL	Power : DC 24V
EUT : 3G Cellular Alarm Communicator	Note : Mode 8: WCDMA Band 2_Link_1907.6MHz

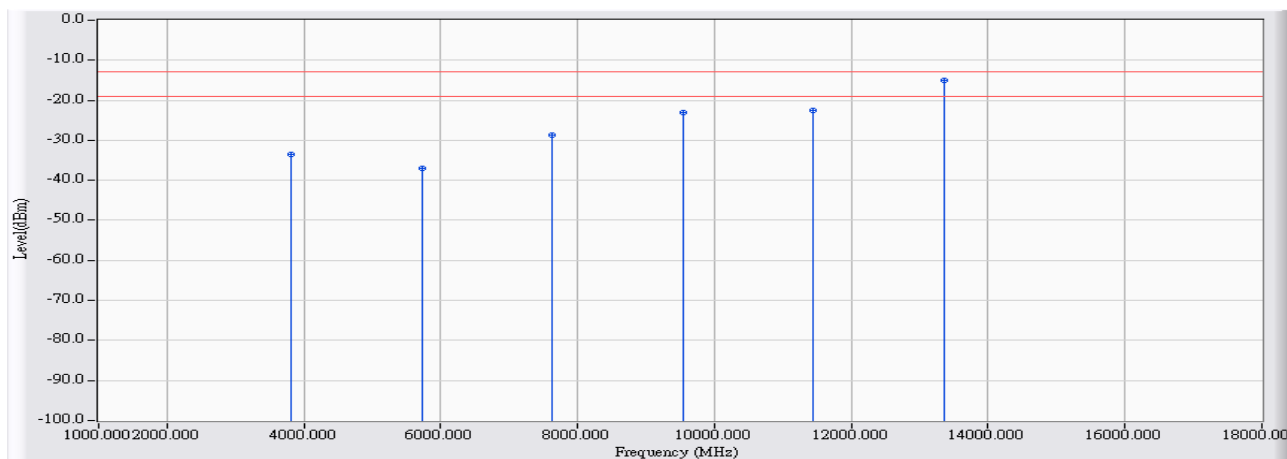

		Frequency (MHz)	Correct Factor (dB)	Reading Level (dBm)	Measure Level (dBm)	Margin (dB)	Limit (dBm)	Detector Type
1		3815.200	19.656	-53.280	-33.624	-20.624	-13.000	PEAK
2		5722.800	21.809	-58.890	-37.081	-24.081	-13.000	PEAK
3		7630.400	29.262	-58.010	-28.747	-15.747	-13.000	PEAK
4		9538.000	34.914	-58.100	-23.185	-10.185	-13.000	PEAK
5		11445.600	36.212	-58.810	-22.598	-9.598	-13.000	PEAK
6	*	13353.200	40.368	-55.330	-14.961	-1.961	-13.000	PEAK

Note:

1. All readings above 1GHz are performed with peak and/or average measurements as necessary.
2. Peak measurements: RBW = 1MHz, VBW = 1MHz, Sweep: Auto.
3. Average measurements: RBW = 1MHz, VBW = 10 Hz, Sweep: Auto.
4. “ \* ”, means this data is the worst emission level.
5. Measurement Level = Reading Level + Correct Factor.
6. The average measurement was not performed when the peak measured data under the limit of average detection.
7. The Emission above 18GHz were not included is because their levels are too low.

Site : CB4-H	Time : 2017/05/31
Limit : FCC_Part22/24_00M_00M_PK	Margin : 6
Probe : CB4-H_CE_Sub_B432_1-18GHz_3M_1116 - HORIZONTAL	Power : DC 24V
EUT : 3G Cellular Alarm Communicator	Note : Mode 9: WCDMA Band 2_HSUPA_Link 1852.4MHz

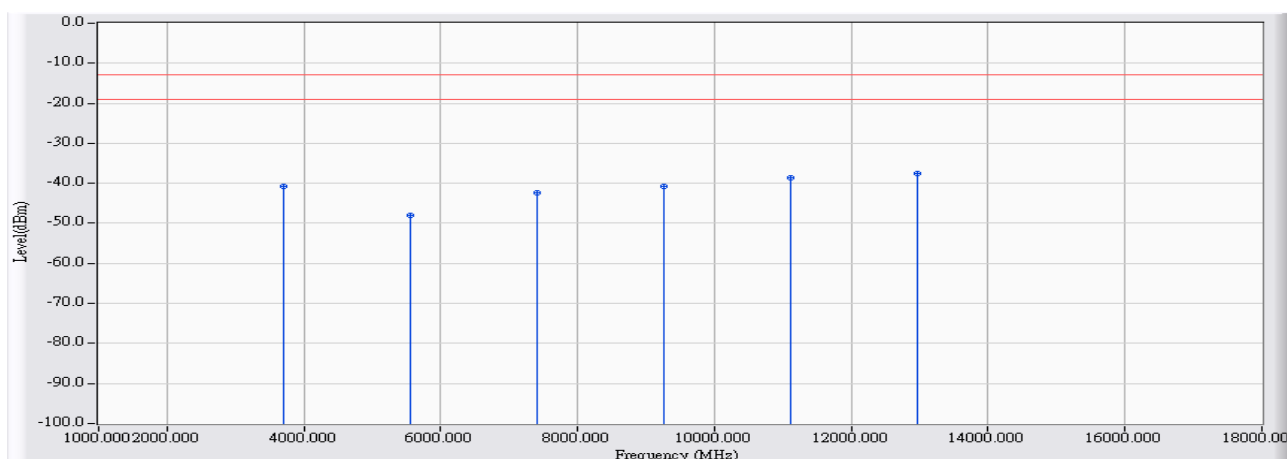

	Frequency (MHz)	Correct Factor (dB)	Reading Level (dBm)	Measure Level (dBm)	Margin (dB)	Limit (dBm)	Detector Type
1	3704.800	18.657	-59.510	-40.853	-27.853	-13.000	PEAK
2	5557.200	21.266	-69.170	-47.904	-34.904	-13.000	PEAK
3	7409.600	28.781	-71.090	-42.309	-29.309	-13.000	PEAK
4	9262.000	33.016	-73.710	-40.695	-27.695	-13.000	PEAK
5	11114.400	36.234	-74.930	-38.695	-25.695	-13.000	PEAK
6	* 12966.800	38.618	-76.250	-37.632	-24.632	-13.000	PEAK

Note:

1. All readings above 1GHz are performed with peak and/or average measurements as necessary.
2. Peak measurements: RBW = 1MHz, VBW = 1MHz, Sweep: Auto.
3. Average measurements: RBW = 1MHz, VBW = 10 Hz, Sweep: Auto.
4. “ \* ”, means this data is the worst emission level.
5. Measurement Level = Reading Level + Correct Factor.
6. The average measurement was not performed when the peak measured data under the limit of average detection.
7. The Emission above 18GHz were not included is because their levels are too low.

Site : CB4-H	Time : 2017/05/31
Limit : FCC_Part22/24_00M_00M_PK	Margin : 6
Probe : CB4-H_CE_Sub_B432_1-18GHz_3M_1116 - VERTICAL	Power : DC 24V
EUT : 3G Cellular Alarm Communicator	Note : Mode 9: WCDMA Band 2_HSUPA_Link _1852.4MHz

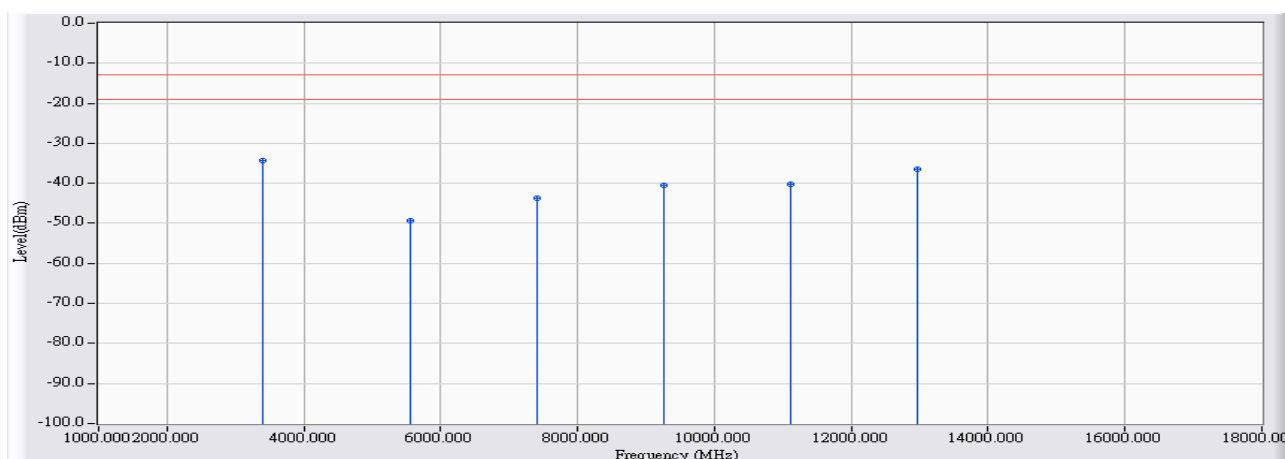

		Frequency (MHz)	Correct Factor (dB)	Reading Level (dBm)	Measure Level (dBm)	Margin (dB)	Limit (dBm)	Detector Type
1	*	3407.800	18.607	-52.860	-34.253	-21.253	-13.000	PEAK
2		5557.200	21.112	-70.520	-49.408	-36.408	-13.000	PEAK
3		7409.600	28.595	-72.320	-43.725	-30.725	-13.000	PEAK
4		9262.000	34.287	-74.710	-40.424	-27.424	-13.000	PEAK
5		11114.400	35.145	-75.280	-40.135	-27.135	-13.000	PEAK
6		12966.800	39.804	-76.360	-36.555	-23.555	-13.000	PEAK

**Note:**

1. All readings above 1GHz are performed with peak and/or average measurements as necessary.
2. Peak measurements: RBW = 1MHz, VBW = 1MHz, Sweep: Auto.
3. Average measurements: RBW = 1MHz, VBW = 10 Hz, Sweep: Auto.
4. “ \* ”, means this data is the worst emission level.
5. Measurement Level = Reading Level + Correct Factor.
6. The average measurement was not performed when the peak measured data under the limit of average detection.
7. The Emission above 18GHz were not included is because their levels are too low.

Site : CB4-H	Time : 2017/05/31
Limit : FCC_Part22/24_00M_00M_PK	Margin : 6
Probe : CB4-H_CE_Sub_B432_1-18GHz_3M_1116 - HORIZONTAL	Power : DC 24V
EUT : 3G Cellular Alarm Communicator	Note : Mode 9: WCDMA Band 2_HSUPA_Link_1880MHz

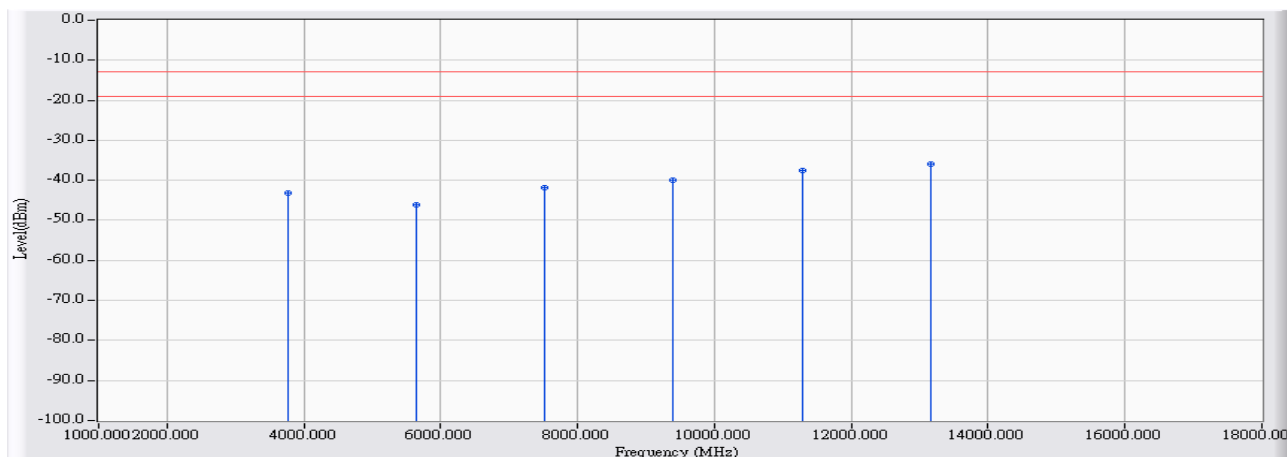

		Frequency (MHz)	Correct Factor (dB)	Reading Level (dBm)	Measure Level (dBm)	Margin (dB)	Limit (dBm)	Detector Type
1		3760.000	18.797	-62.090	-43.294	-30.294	-13.000	PEAK
2		5640.000	21.619	-67.830	-46.211	-33.211	-13.000	PEAK
3		7520.000	28.931	-70.730	-41.799	-28.799	-13.000	PEAK
4		9400.000	33.161	-73.020	-39.858	-26.858	-13.000	PEAK
5		11280.000	36.329	-73.890	-37.561	-24.561	-13.000	PEAK
6	*	13160.000	38.672	-74.480	-35.808	-22.808	-13.000	PEAK

Note:

1. All readings above 1GHz are performed with peak and/or average measurements as necessary.
2. Peak measurements: RBW = 1MHz, VBW = 1MHz, Sweep: Auto.
3. Average measurements: RBW = 1MHz, VBW = 10 Hz, Sweep: Auto.
4. “ \* ”, means this data is the worst emission level.
5. Measurement Level = Reading Level + Correct Factor.
6. The average measurement was not performed when the peak measured data under the limit of average detection.
7. The Emission above 18GHz were not included is because their levels are too low.

Site : CB4-H	Time : 2017/05/31
Limit : FCC_Part22/24_00M_00M_PK	Margin : 6
Probe : CB4-H_CE_Sub_B432_1-18GHz_3M_1116 - VERTICAL	Power : DC 24V
EUT : 3G Cellular Alarm Communicator	Note : Mode 9: WCDMA Band 2_HSUPA_Link_1880MHz

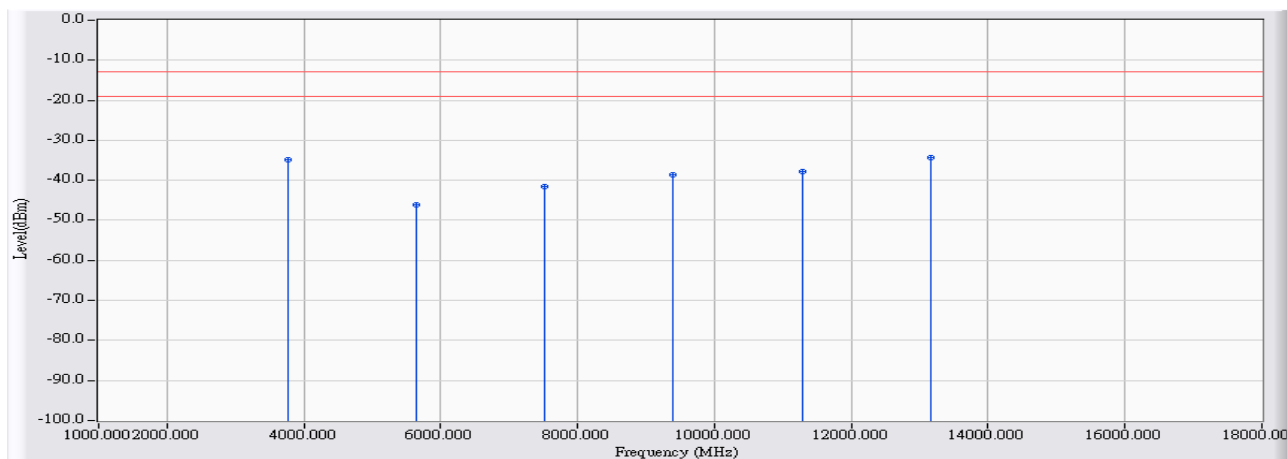

		Frequency (MHz)	Correct Factor (dB)	Reading Level (dBm)	Measure Level (dBm)	Margin (dB)	Limit (dBm)	Detector Type
1		3760.000	19.589	-54.470	-34.881	-21.881	-13.000	PEAK
2		5640.000	21.461	-67.500	-46.039	-33.039	-13.000	PEAK
3		7520.000	29.017	-70.500	-41.484	-28.484	-13.000	PEAK
4		9400.000	34.623	-73.230	-38.606	-25.606	-13.000	PEAK
5		11280.000	35.703	-73.470	-37.767	-24.767	-13.000	PEAK
6	*	13160.000	39.992	-74.330	-34.338	-21.338	-13.000	PEAK

Note:

1. All readings above 1GHz are performed with peak and/or average measurements as necessary.
2. Peak measurements: RBW = 1MHz, VBW = 1MHz, Sweep: Auto.
3. Average measurements: RBW = 1MHz, VBW = 10 Hz, Sweep: Auto.
4. “ \* ”, means this data is the worst emission level.
5. Measurement Level = Reading Level + Correct Factor.
6. The average measurement was not performed when the peak measured data under the limit of average detection.
7. The Emission above 18GHz were not included is because their levels are too low.

Site : CB4-H	Time : 2017/05/31
Limit : FCC_Part22/24_00M_00M_PK	Margin : 6
Probe : CB4-H_CE_Sub_B432_1-18GHz_3M_1116 - HORIZONTAL	Power : DC 24V
EUT : 3G Cellular Alarm Communicator	Note : Mode 9: WCDMA Band 2_HSUPA_Link _1907.6MHz

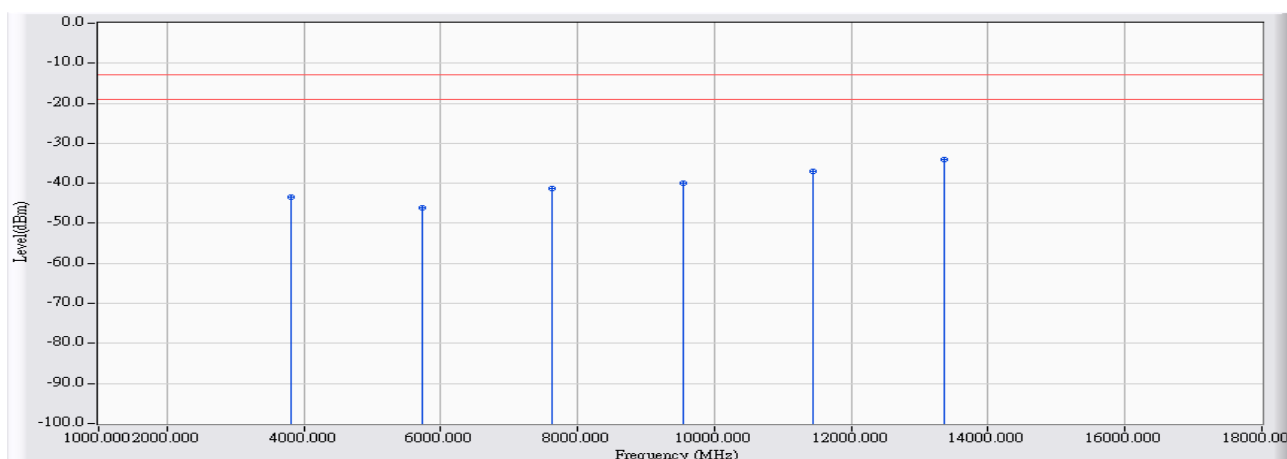

	Frequency (MHz)	Correct Factor (dB)	Reading Level (dBm)	Measure Level (dBm)	Margin (dB)	Limit (dBm)	Detector Type
1	3815.200	18.884	-62.440	-43.556	-30.556	-13.000	PEAK
2	5722.800	21.972	-68.040	-46.067	-33.067	-13.000	PEAK
3	7630.400	29.366	-70.690	-41.323	-28.323	-13.000	PEAK
4	9538.000	33.377	-73.230	-39.852	-26.852	-13.000	PEAK
5	11445.600	36.375	-73.330	-36.956	-23.956	-13.000	PEAK
6	* 13353.200	38.844	-72.780	-33.935	-20.935	-13.000	PEAK

**Note:**

1. All readings above 1GHz are performed with peak and/or average measurements as necessary.
2. Peak measurements: RBW = 1MHz, VBW = 1MHz, Sweep: Auto.
3. Average measurements: RBW = 1MHz, VBW = 10 Hz, Sweep: Auto.
4. “ \* ”, means this data is the worst emission level.
5. Measurement Level = Reading Level + Correct Factor.
6. The average measurement was not performed when the peak measured data under the limit of average detection.
7. The Emission above 18GHz were not included is because their levels are too low.

Site : CB4-H	Time : 2017/05/31
Limit : FCC_Part22/24_00M_00M_PK	Margin : 6
Probe : CB4-H_CE_Sub_B432_1-18GHz_3M_1116 - VERTICAL	Power : DC 24V
EUT : 3G Cellular Alarm Communicator	Note : Mode 9: WCDMA Band 2_HSUPA_Link _1907.6MHz

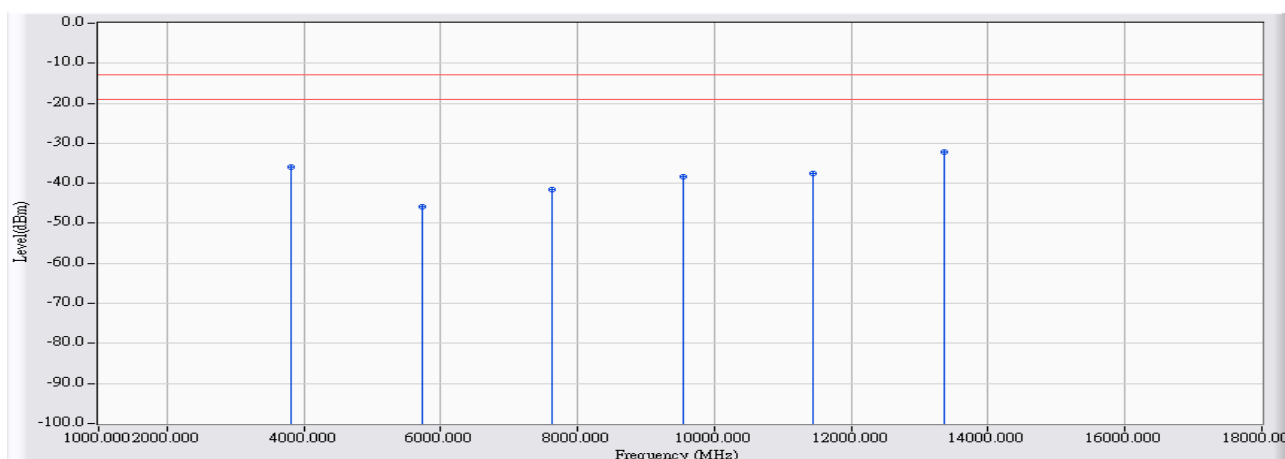

		Frequency (MHz)	Correct Factor (dB)	Reading Level (dBm)	Measure Level (dBm)	Margin (dB)	Limit (dBm)	Detector Type
1		3815.200	19.656	-55.580	-35.924	-22.924	-13.000	PEAK
2		5722.800	21.809	-67.750	-45.941	-32.941	-13.000	PEAK
3		7630.400	29.262	-70.900	-41.637	-28.637	-13.000	PEAK
4		9538.000	34.914	-73.350	-38.435	-25.435	-13.000	PEAK
5		11445.600	36.212	-73.700	-37.488	-24.488	-13.000	PEAK
6	*	13353.200	40.368	-72.620	-32.251	-19.251	-13.000	PEAK

**Note:**

1. All readings above 1GHz are performed with peak and/or average measurements as necessary.
2. Peak measurements: RBW = 1MHz, VBW = 1MHz, Sweep: Auto.
3. Average measurements: RBW = 1MHz, VBW = 10 Hz, Sweep: Auto.
4. “ \* ”, means this data is the worst emission level.
5. Measurement Level = Reading Level + Correct Factor.
6. The average measurement was not performed when the peak measured data under the limit of average detection.
7. The Emission above 18GHz were not included is because their levels are too low.



<b>Site : CB4-H</b>	<b>Time : 2017/05/31</b>
<b>Limit : FCC_Part22/24_00M_00M_PK</b>	<b>Margin : 6</b>
<b>Probe : CB4-H_CE_Sub_B432_1-18GHz_3M_1116 - HORIZONTAL</b>	<b>Power : DC 24V</b>
<b>EUT : 3G Cellular Alarm Communicator</b>	<b>Note : Mode 10: WCDMA Band 2_HSDPA_Link 1852.4MHz</b>

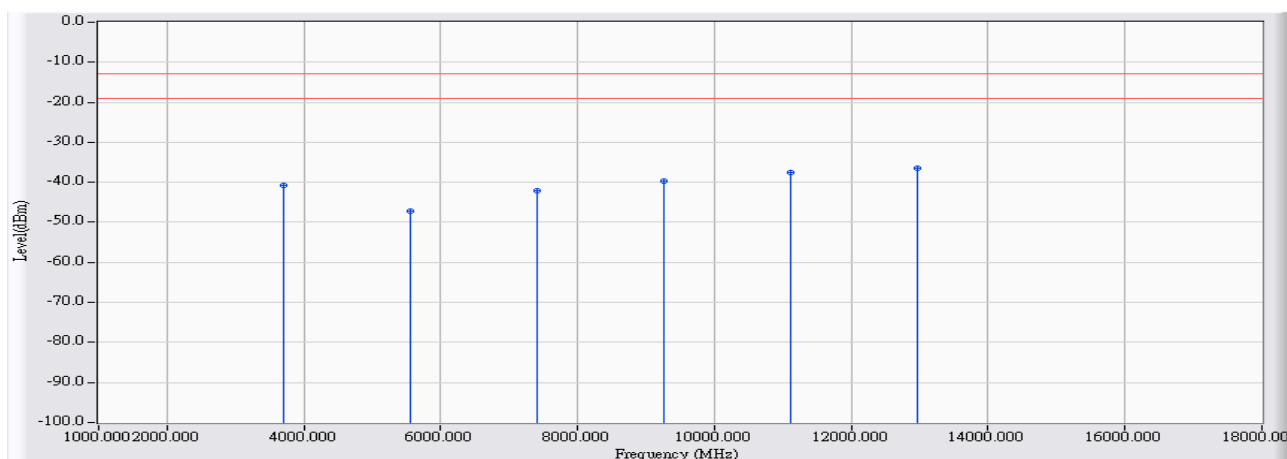

		<b>Frequency (MHz)</b>	<b>Correct Factor (dB)</b>	<b>Reading Level (dBm)</b>	<b>Measure Level (dBm)</b>	<b>Margin (dB)</b>	<b>Limit (dBm)</b>	<b>Detector Type</b>
1		3704.800	18.657	-59.370	-40.713	-27.713	-13.000	PEAK
2		5557.200	21.266	-68.530	-47.264	-34.264	-13.000	PEAK
3		7409.600	28.781	-70.790	-42.009	-29.009	-13.000	PEAK
4		9262.000	33.016	-72.660	-39.645	-26.645	-13.000	PEAK
5		11114.400	36.234	-73.870	-37.635	-24.635	-13.000	PEAK
6	*	12966.800	38.618	-75.010	-36.392	-23.392	-13.000	PEAK

**Note:**

1. All readings above 1GHz are performed with peak and/or average measurements as necessary.
2. Peak measurements: RBW = 1MHz, VBW = 1MHz, Sweep: Auto.
3. Average measurements: RBW = 1MHz, VBW = 10 Hz, Sweep: Auto.
4. “ \* ”, means this data is the worst emission level.
5. Measurement Level = Reading Level + Correct Factor.
6. The average measurement was not performed when the peak measured data under the limit of average detection.
7. The Emission above 18GHz were not included is because their levels are too low.

Site : CB4-H	Time : 2017/05/31
Limit : FCC_Part22/24_00M_00M_PK	Margin : 6
Probe : CB4-H_CE_Sub_B432_1-18GHz_3M_1116 - VERTICAL	Power : DC 24V
EUT : 3G Cellular Alarm Communicator	Note : Mode 10: WCDMA Band 2_HSDPA_Link 1852.4MHz

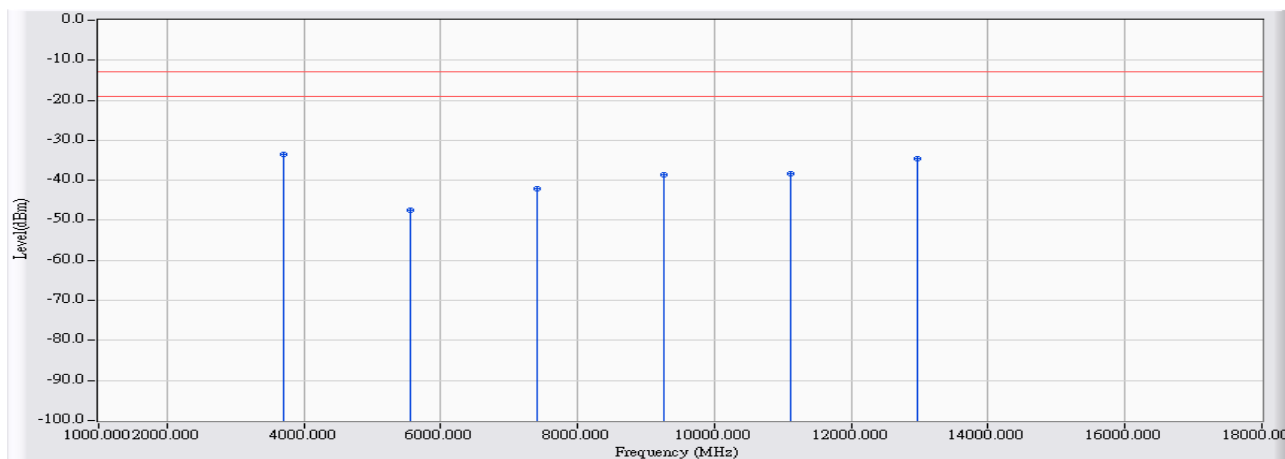

		Frequency (MHz)	Correct Factor (dB)	Reading Level (dBm)	Measure Level (dBm)	Margin (dB)	Limit (dBm)	Detector Type
1	*	3704.800	19.458	-53.070	-33.612	-20.612	-13.000	PEAK
2		5557.200	21.112	-68.520	-47.408	-34.408	-13.000	PEAK
3		7409.600	28.595	-70.740	-42.145	-29.145	-13.000	PEAK
4		9262.000	34.287	-72.790	-38.504	-25.504	-13.000	PEAK
5		11114.400	35.145	-73.530	-38.385	-25.385	-13.000	PEAK
6		12966.800	39.804	-74.300	-34.495	-21.495	-13.000	PEAK

Note:

1. All readings above 1GHz are performed with peak and/or average measurements as necessary.
2. Peak measurements: RBW = 1MHz, VBW = 1MHz, Sweep: Auto.
3. Average measurements: RBW = 1MHz, VBW = 10 Hz, Sweep: Auto.
4. “ \* ”, means this data is the worst emission level.
5. Measurement Level = Reading Level + Correct Factor.
6. The average measurement was not performed when the peak measured data under the limit of average detection.
7. The Emission above 18GHz were not included is because their levels are too low.

<b>Site : CB4-H</b>	<b>Time : 2017/05/31</b>
<b>Limit : FCC_Part22/24_00M_00M_PK</b>	<b>Margin : 6</b>
<b>Probe : CB4-H_CE_Sub_B432_1-18GHz_3M_1116 - HORIZONTAL</b>	<b>Power : DC 24V</b>
<b>EUT : 3G Cellular Alarm Communicator</b>	<b>Note : Mode 10: WCDMA Band 2_HSDPA_Link 1880MHz</b>

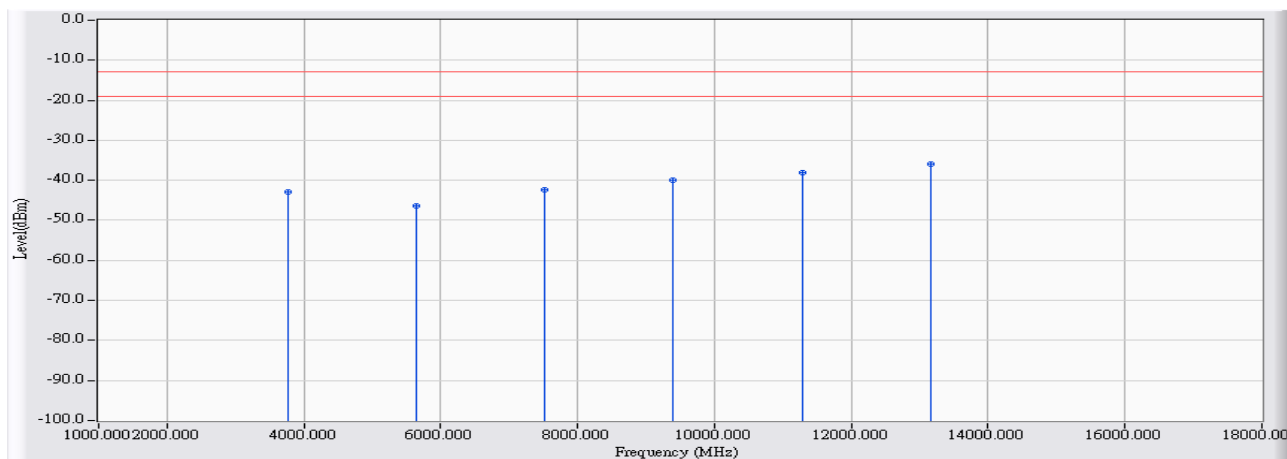

		<b>Frequency (MHz)</b>	<b>Correct Factor (dB)</b>	<b>Reading Level (dBm)</b>	<b>Measure Level (dBm)</b>	<b>Margin (dB)</b>	<b>Limit (dBm)</b>	<b>Detector Type</b>
1		3760.000	18.797	-61.710	-42.914	-29.914	-13.000	PEAK
2		5640.000	21.619	-68.050	-46.431	-33.431	-13.000	PEAK
3		7520.000	28.931	-71.370	-42.439	-29.439	-13.000	PEAK
4		9400.000	33.161	-73.050	-39.888	-26.888	-13.000	PEAK
5		11280.000	36.329	-74.350	-38.021	-25.021	-13.000	PEAK
6	*	13160.000	38.672	-74.580	-35.908	-22.908	-13.000	PEAK

**Note:**

1. All readings above 1GHz are performed with peak and/or average measurements as necessary.
2. Peak measurements: RBW = 1MHz, VBW = 1MHz, Sweep: Auto.
3. Average measurements: RBW = 1MHz, VBW = 10 Hz, Sweep: Auto.
4. “ \* ”, means this data is the worst emission level.
5. Measurement Level = Reading Level + Correct Factor.
6. The average measurement was not performed when the peak measured data under the limit of average detection.
7. The Emission above 18GHz were not included is because their levels are too low.

Site : CB4-H	Time : 2017/05/31
Limit : FCC_Part22/24_00M_00M_PK	Margin : 6
Probe : CB4-H_CE_Sub_B432_1-18GHz_3M_1116 - VERTICAL	Power : DC 24V
EUT : 3G Cellular Alarm Communicator	Note : Mode 10: WCDMA Band 2_HSDPA_Link _1880MHz

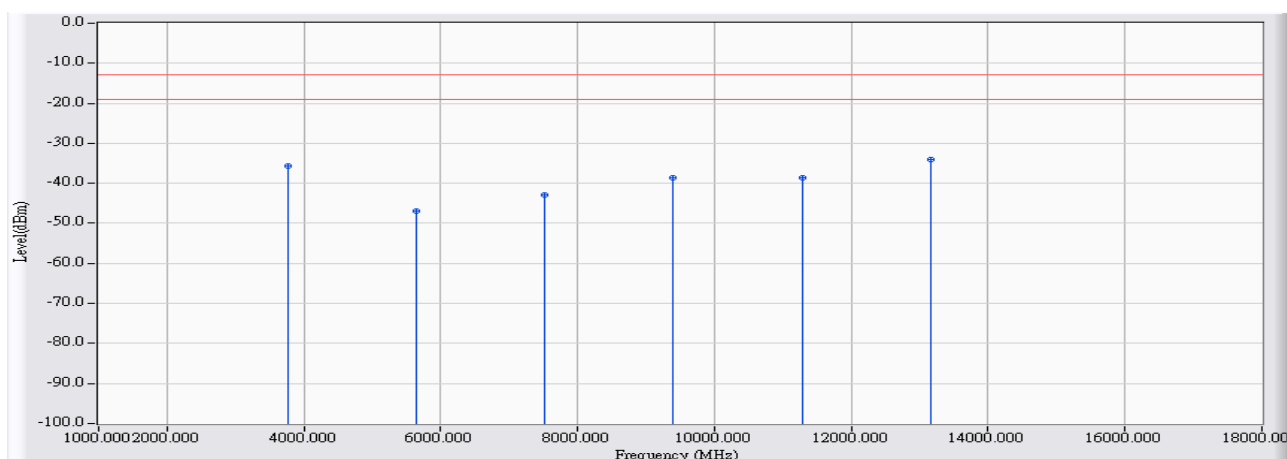

	Frequency (MHz)	Correct Factor (dB)	Reading Level (dBm)	Measure Level (dBm)	Margin (dB)	Limit (dBm)	Detector Type
1	3760.000	19.589	-55.140	-35.551	-22.551	-13.000	PEAK
2	5640.000	21.461	-68.370	-46.909	-33.909	-13.000	PEAK
3	7520.000	29.017	-71.820	-42.804	-29.804	-13.000	PEAK
4	9400.000	34.623	-73.320	-38.696	-25.696	-13.000	PEAK
5	11280.000	35.703	-74.420	-38.717	-25.717	-13.000	PEAK
6	* 13160.000	39.992	-74.120	-34.128	-21.128	-13.000	PEAK

Note:

1. All readings above 1GHz are performed with peak and/or average measurements as necessary.
2. Peak measurements: RBW = 1MHz, VBW = 1MHz, Sweep: Auto.
3. Average measurements: RBW = 1MHz, VBW = 10 Hz, Sweep: Auto.
4. “ \* ”, means this data is the worst emission level.
5. Measurement Level = Reading Level + Correct Factor.
6. The average measurement was not performed when the peak measured data under the limit of average detection.
7. The Emission above 18GHz were not included is because their levels are too low.

Site : CB4-H	Time : 2017/05/31
Limit : FCC_Part22/24_00M_00M_PK	Margin : 6
Probe : CB4-H_CE_Sub_B432_1-18GHz_3M_1116 - HORIZONTAL	Power : DC 24V
EUT : 3G Cellular Alarm Communicator	Note : Mode 10: WCDMA Band 2_HSDPA_Link _1907.6MHz

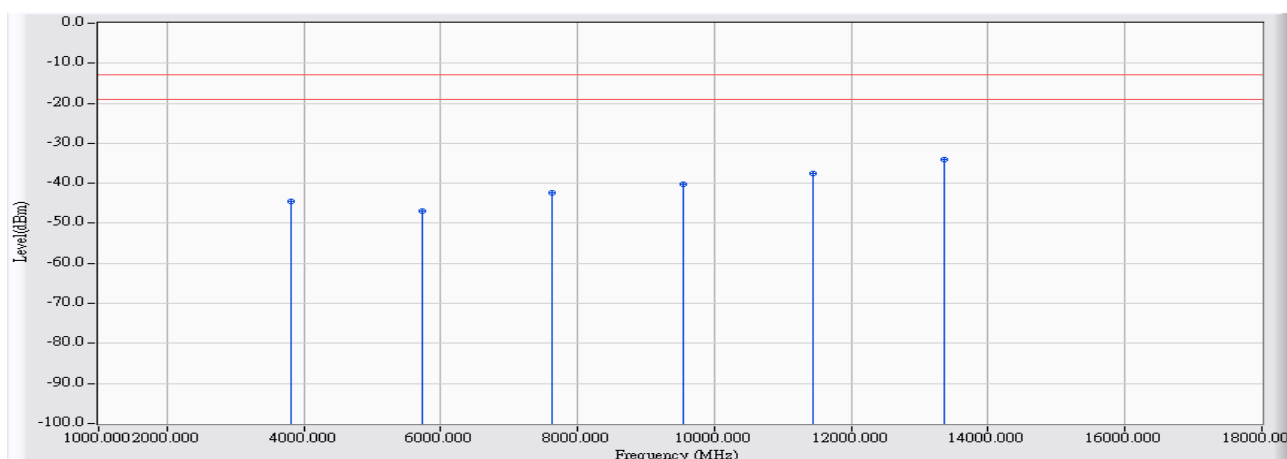

	Frequency (MHz)	Correct Factor (dB)	Reading Level (dBm)	Measure Level (dBm)	Margin (dB)	Limit (dBm)	Detector Type
1	3815.200	18.884	-63.340	-44.456	-31.456	-13.000	PEAK
2	5722.800	21.972	-68.800	-46.827	-33.827	-13.000	PEAK
3	7630.000	29.365	-71.640	-42.274	-29.274	-13.000	PEAK
4	9538.000	33.377	-73.610	-40.232	-27.232	-13.000	PEAK
5	11445.600	36.375	-74.020	-37.646	-24.646	-13.000	PEAK
6	* 13353.200	38.844	-73.000	-34.155	-21.155	-13.000	PEAK

Note:

1. All readings above 1GHz are performed with peak and/or average measurements as necessary.
2. Peak measurements: RBW = 1MHz, VBW = 1MHz, Sweep: Auto.
3. Average measurements: RBW = 1MHz, VBW = 10 Hz, Sweep: Auto.
4. “ \* ”, means this data is the worst emission level.
5. Measurement Level = Reading Level + Correct Factor.
6. The average measurement was not performed when the peak measured data under the limit of average detection.
7. The Emission above 18GHz were not included is because their levels are too low.

Site : CB4-H	Time : 2017/05/31
Limit : FCC_Part22/24_00M_00M_PK	Margin : 6
Probe : CB4-H_CE_Sub_B432_1-18GHz_3M_1116 - VERTICAL	Power : DC 24V
EUT : 3G Cellular Alarm Communicator	Note : Mode 10: WCDMA Band 2_HSDPA_Link _1907.6MHz

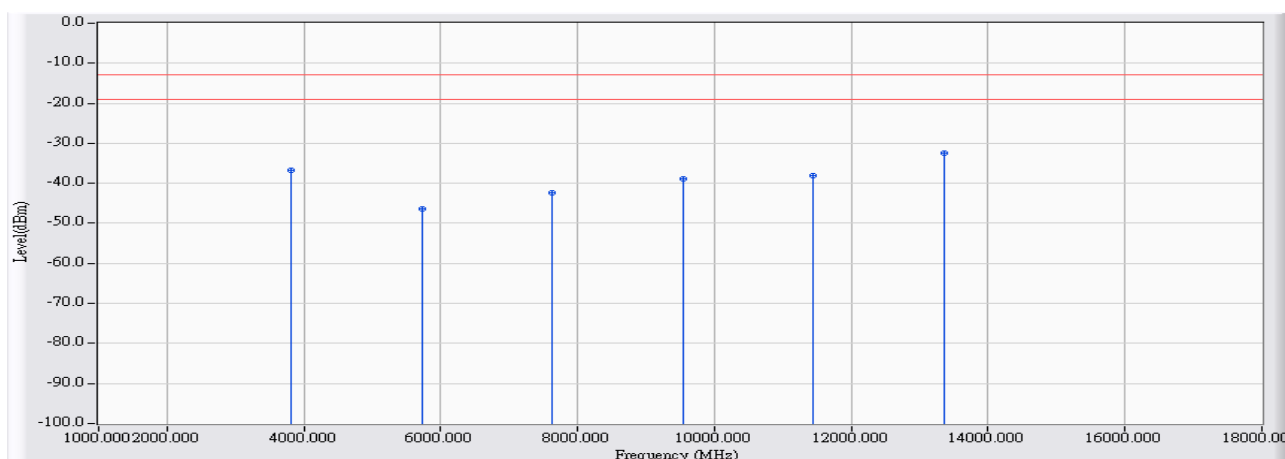

		Frequency (MHz)	Correct Factor (dB)	Reading Level (dBm)	Measure Level (dBm)	Margin (dB)	Limit (dBm)	Detector Type
1		3815.200	19.656	-56.320	-36.664	-23.664	-13.000	PEAK
2		5722.800	21.809	-68.260	-46.451	-33.451	-13.000	PEAK
3		7630.400	29.262	-71.640	-42.377	-29.377	-13.000	PEAK
4		9538.000	34.914	-73.690	-38.775	-25.775	-13.000	PEAK
5		11445.600	36.212	-74.190	-37.978	-24.978	-13.000	PEAK
6	*	13353.200	40.368	-72.910	-32.541	-19.541	-13.000	PEAK

Note:

1. All readings above 1GHz are performed with peak and/or average measurements as necessary.
2. Peak measurements: RBW = 1MHz, VBW = 1MHz, Sweep: Auto.
3. Average measurements: RBW = 1MHz, VBW = 10 Hz, Sweep: Auto.
4. “ \* ”, means this data is the worst emission level.
5. Measurement Level = Reading Level + Correct Factor.
6. The average measurement was not performed when the peak measured data under the limit of average detection.
7. The Emission above 18GHz were not included is because their levels are too low.

## 7. Frequency Stability Under Temperature & Voltage Variations

### 7.1. Test Equipment

Frequency Stability Under Temperature & Voltage Variations / SR10-H

Instrument	Manufacturer	Type No.	Serial No	Cali. Due Date
Signal & Spectrum Analyzer	R&S	FSV40	101049	2018/01/22
Temperature & Humidity Chamber	WIT	TH-1S-B	1082101	2018/01/18

### 7.2. Test Setup

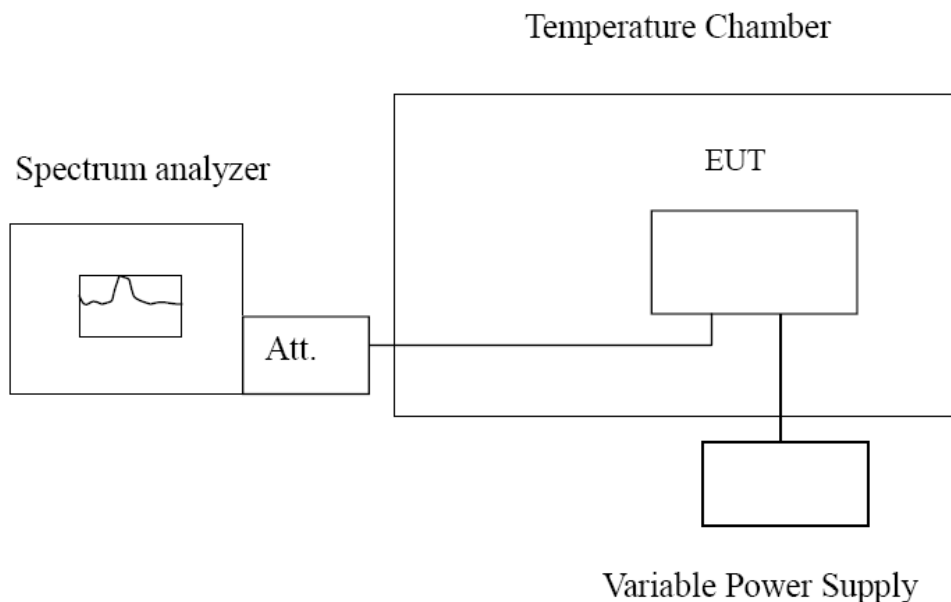

### 7.3. Test Procedure

#### Frequency Stability Under Temperature Variations:

The equipment under test was connected to an external AC or DC power supply and input rated voltage. RF output was connected to a frequency counter or spectrum analyzer via feed through attenuators. The EUT was placed inside the temperature chamber. Set the spectrum analyzer RBW low enough to obtain the desired frequency resolution and measure EUT 20°C operating frequency as reference frequency. Turn EUT off and set the chamber temperature to -30°C. After the temperature stabilized for approximately 30 minutes recorded the frequency. Repeat step measure with 10°C increased per stage until the highest temperature of +50°C reached.

#### Frequency Stability Under Voltage Variations:

Set chamber temperature to 20°C. Use a variable AC power supply / DC power source to power the EUT and set the voltage to rated voltage. Set the spectrum analyzer RBW low enough to obtain the desired frequency resolution and recorded the frequency.

Reduce the input voltage to specify extreme voltage variation ( $\pm 15\%$ ) and endpoint, record the maximum frequency change.

### 7.4. Uncertainty

The measurement uncertainty is defined as  $\pm 10$  Hz.



## 7.5. Test Result

Product	3G Cellular Alarm Communicator		
Test Item	Frequency Stability Under Temperature & Voltage Variations		
Test Mode	Mode 1: GPRS 850_Link		
Date of Test	2017/05/23	Test Site	SR10-H

824.2 MHz

### Frequency Stability under Voltage

DC Voltage (V)	Frequency Error (Hz)	Frequency Error (ppm)
26.4	10	-0.0118
24	9	-0.0108
21.6	11	-0.0130

### Frequency Stability under Temperature

Temperature	Frequency Error (Hz)	Frequency Error (ppm)
-30	10	-0.0123
-20	9	-0.0114
-10	10	-0.0123
0	9	-0.0113
+10	11	-0.0138
+20	9	-0.0108
+30	14	-0.0166
+40	12	-0.0150
+50	10	-0.0119

Product	3G Cellular Alarm Communicator		
Test Item	Frequency Stability Under Temperature & Voltage Variations		
Test Mode	Mode 1: GPRS 850_Link		
Date of Test	2017/05/23	Test Site	SR10-H

836.6 MHz

## Frequency Stability under Voltage

DC Voltage (V)	Frequency Error (Hz)	Frequency Error (ppm)
26.4	16	-0.0192
24	11	-0.0127
21.6	11	-0.0128

## Frequency Stability under Temperature

Temperature	Frequency Error (Hz)	Frequency Error (ppm)
-30	16	-0.0188
-20	13	-0.0160
-10	-12	0.0143
0	-14	0.0169
+10	15	-0.0180
+20	-11	0.0131
+30	-13	0.0155
+40	10	-0.0123
+50	11	-0.0128

Product	3G Cellular Alarm Communicator		
Test Item	Frequency Stability Under Temperature & Voltage Variations		
Test Mode	Mode 1: GPRS 850_Link		
Date of Test	2017/05/23	Test Site	SR10-H

848.8 MHz

Frequency Stability under Voltage

DC Voltage (V)	Frequency Error (Hz)	Frequency Error (ppm)
26.4	9	-0.0107
24	-14	0.0164
21.6	-12	0.0141

Frequency Stability under Temperature

Temperature	Frequency Error (Hz)	Frequency Error (ppm)
-30	11	-0.0128
-20	-14	0.0165
-10	-11	0.0132
0	9	-0.0101
+10	9	-0.0100
+20	-14	0.0164
+30	14	-0.0165
+40	10	-0.0113
+50	13	-0.0156

Product	3G Cellular Alarm Communicator		
Test Item	Frequency Stability Under Temperature & Voltage Variations		
Test Mode	Mode 2: GPRS 1900_Link		
Date of Test	2017/05/23	Test Site	SR10-H

1850.2 MHz

## Frequency Stability under Voltage

DC Voltage (V)	Frequency Error (Hz)	Frequency Error (ppm)
26.4	-16	0.0085
24	-15	0.0079
21.6	18	-0.0099

## Frequency Stability under Temperature

Temperature	Frequency Error (Hz)	Frequency Error (ppm)
-30	21	-0.0112
-20	-18	0.0095
-10	-21	0.0115
0	13	-0.0070
+10	16	-0.0086
+20	-15	0.0079
+30	16	-0.0086
+40	-16	0.0086
+50	18	-0.0096

Product	3G Cellular Alarm Communicator		
Test Item	Frequency Stability Under Temperature & Voltage Variations		
Test Mode	Mode 2: GPRS 1900_Link		
Date of Test	2017/05/23	Test Site	SR10-H

1880.0 MHz

## Frequency Stability under Voltage

DC Voltage (V)	Frequency Error (Hz)	Frequency Error (ppm)
26.4	14	-0.0076
24	17	-0.0091
21.6	-17	0.0089

## Frequency Stability under Temperature

Temperature	Frequency Error (Hz)	Frequency Error (ppm)
-30	-15	0.0079
-20	-27	0.0144
-10	16	-0.0083
0	-24	0.0129
+10	-15	0.0079
+20	17	-0.0091
+30	-15	0.0081
+40	16	-0.0082
+50	-14	0.0077

Product	3G Cellular Alarm Communicator		
Test Item	Frequency Stability Under Temperature & Voltage Variations		
Test Mode	Mode 2: GPRS 1900_Link		
Date of Test	2017/05/23	Test Site	SR10-H

1909.8 MHz

## Frequency Stability under Voltage

DC Voltage (V)	Frequency Error (Hz)	Frequency Error (ppm)
26.4	17	-0.0090
24	15	-0.0078
21.6	-19	0.0097

## Frequency Stability under Temperature

Temperature	Frequency Error (Hz)	Frequency Error (ppm)
-30	14	-0.0071
-20	18	-0.0094
-10	11	-0.0060
0	15	-0.0076
+10	14	-0.0071
+20	15	-0.0078
+30	13	-0.0070
+40	11	-0.0058
+50	22	-0.0113

Product	3G Cellular Alarm Communicator		
Test Item	Frequency Stability Under Temperature & Voltage Variations		
Test Mode	Mode 5: WCDMA Band 5_Link		
Date of Test	2017/05/23	Test Site	SR10-H

826.4 MHz

Frequency Stability under Voltage

DC Voltage (V)	Frequency Error (Hz)	Frequency Error (ppm)
4.2	11	-0.0130
3.7	24	-0.0293
3.4	35	-0.0424

Frequency Stability under Temperature

Temperature	Frequency Error (Hz)	Frequency Error (ppm)
-30	16	-0.0188
-20	20	-0.0239
-10	26	-0.0312
0	26	-0.0317
+10	13	-0.0160
+20	24	-0.0293
+30	24	-0.0286
+40	26	-0.0314
+50	18	-0.0220

Product	3G Cellular Alarm Communicator		
Test Item	Frequency Stability Under Temperature & Voltage Variations		
Test Mode	Mode 5: WCDMA Band 5_Link		
Date of Test	2017/05/23	Test Site	SR10-H

836.6 MHz

Frequency Stability under Voltage

DC Voltage (V)	Frequency Error (Hz)	Frequency Error (ppm)
4.2	24	-0.0286
3.7	-21	0.0250
3.4	-31	0.0367

Frequency Stability under Temperature

Temperature	Frequency Error (Hz)	Frequency Error (ppm)
-30	-15	0.0178
-20	-27	0.0317
-10	-13	0.0161
0	-19	0.0230
+10	-23	0.0272
+20	-21	0.0250
+30	-27	0.0317
+40	-27	0.0319
+50	-7	0.0088



Product	3G Cellular Alarm Communicator		
Test Item	Frequency Stability Under Temperature & Voltage Variations		
Test Mode	Mode 5: WCDMA Band 5_Link		
Date of Test	2017/05/23	Test Site	SR10-H

846.6 MHz

Frequency Stability under Voltage

DC Voltage (V)	Frequency Error (Hz)	Frequency Error (ppm)
4.2	16	-0.0194
3.7	-19	0.0230
3.4	-27	0.0321

Frequency Stability under Temperature

Temperature	Frequency Error (Hz)	Frequency Error (ppm)
-30	-28	0.0331
-20	-28	0.0329
-10	-27	0.0320
0	-26	0.0312
+10	-27	0.0319
+20	-19	0.0230
+30	-27	0.0322
+40	-27	0.0321
+50	-29	0.0346

Product	3G Cellular Alarm Communicator		
Test Item	Frequency Stability Under Temperature & Voltage Variations		
Test Mode	Mode 8: WCDMA Band 2_Link		
Date of Test	2017/05/23	Test Site	SR10-H

1852.4 MHz

## Frequency Stability under Voltage

DC Voltage (V)	Frequency Error (Hz)	Frequency Error (ppm)
4.2	-29	0.0158
3.7	32	-0.0173
3.4	-31	0.0168

## Frequency Stability under Temperature

Temperature	Frequency Error (Hz)	Frequency Error (ppm)
-30	-55	0.0298
-20	-55	0.0296
-10	-54	0.0290
0	-53	0.0286
+10	-53	0.0287
+20	32	-0.0173
+30	-18	0.0095
+40	-20	0.0110
+50	-17	0.0090

Product	3G Cellular Alarm Communicator		
Test Item	Frequency Stability Under Temperature & Voltage Variations		
Test Mode	Mode 8: WCDMA Band 2_Link		
Date of Test	2017/05/23	Test Site	SR10-H

1880.0 MHz

## Frequency Stability under Voltage

DC Voltage (V)	Frequency Error (Hz)	Frequency Error (ppm)
4.2	41	-0.0220
3.7	34	-0.0179
3.4	-53	0.0283

## Frequency Stability under Temperature

Temperature	Frequency Error (Hz)	Frequency Error (ppm)
-30	-26	0.0138
-20	-14	0.0076
-10	-14	0.0074
0	-9	0.0047
+10	-9	0.0047
+20	34	-0.0179
+30	10	-0.0051
+40	10	-0.0055
+50	14	-0.0075

Product	3G Cellular Alarm Communicator		
Test Item	Frequency Stability Under Temperature & Voltage Variations		
Test Mode	Mode 8: WCDMA Band 2_Link		
Date of Test	2017/05/23	Test Site	SR10-H

1907.6 MHz

## Frequency Stability under Voltage

DC Voltage (V)	Frequency Error (Hz)	Frequency Error (ppm)
4.2	-54	0.0284
3.7	-57	0.0301
3.4	-57	0.0296

## Frequency Stability under Temperature

Temperature	Frequency Error (Hz)	Frequency Error (ppm)
-30	-19	0.0101
-20	-9	0.0045
-10	13	-0.0068
0	19	-0.0097
+10	23	-0.0118
+20	-57	0.0301
+30	23	-0.0120
+40	30	-0.0155
+50	32	-0.0168