

3G4010

**3G (HSPA) WIRELESS ALARM
COMMUNICATOR**

INSTALLATION MANUAL V4.0



WARNING: This manual contains information on limitations regarding product use and function and information on the limitations as to liability of the manufacturer. The entire manual should be carefully read.

TABLE OF CONTENTS

Introduction	1
Features	1
Technical Specifications	1
Ratings	1
Identification of Parts	2
Description	3
Installing the 3G4010	4
Connecting the 3G4010	4
Status LEDs	5
Operating Principles	6
Simulated Landline Mode	6
Panel Transmission Monitoring (PTM)	6
Wireless Communications Sequence	6
Inputs	6
Outputs	7
Activating the Outputs	7
Swinger Shutdown	7
Hardware Default	7
Low Power Radio Shutdown	8
CONNECT 24 Remote Programming	8
Troubleshooting Guide	8
3G4010 Wiring Diagrams	12

IMPORTANT

The equipment is fixed, wall-mounted and shall be installed in the position specified in these instructions. The equipment enclosure must be fully assembled and closed, with all the necessary screws/tabs and secured to a wall before operation. Internal wiring must be routed in a manner that prevents:

- Excessive strain on wire and on terminal connections
- Loosening of terminal; connections
- Damage of conductor insulation

WARNING: Never install this equipment during a lightning storm!

Instruct the end-user to:

- Not attempt to service this product. Opening or removing covers may expose the user to dangerous voltages or other risks. Any servicing shall be referred to trained service persons only.
- Use authorized accessories only with this equipment.

Do not dispose of the battery in fire or water. Disposing of the battery in a fire will cause rupture and explosion.

Do not dispose of the waste battery as unsorted municipal waste. Consult your local regulations and /or laws regarding recycling with regard to this lithium battery pack. Doing so will help protect the environment. Some of the materials that are found within the battery could become toxic if not disposed of properly and may affect the environment.

Introduction

The 3G4010 is a wireless communicator that sends alarm system information to an Sur-Gard System I, II, III or IV receiver through a 3G (HSPA) or 2G (GPRS) wireless network. This wireless communicator can be used with UL/ULC Listed compatible control units, as indicated in the manufacturer's installation instructions.

NOTE: The 3G4010 is designed to work with SIA and the Contact ID communication format as described in SIA DC-05 Standard. Before completing the field installation of the alarm monitoring system please ensure communication with the supervising central station is successful by sending several events and getting confirmation that they have been received.

Features

- Compatible with 4-digit or 10-digit Contact ID communication format as described in SIA DC-05 Standard. Example of suitable compatible alarm panels: DSC Models PC1864, PC1832, PC1616, PC4020.
- Simulates landline
- Switches automatically to the 3G (HSPA) or 2G (GPRS) network in the event of landline trouble (e.g., line down)
- Wireless Signal Indicator
- Four programmable outputs
- Contains one 12V - 1.2 Ah battery
- Case Tamper Output
- Landline overvoltage protection
- Tri-band UMTS/HSPA; Quad-Band GSM/EDGE Radio
- Four programmable inputs
- 3G (HSPA)/2G (GPRS) / Internet communication with Sur-Gard System I / II / III / IV
- Panel transmission monitoring for up to four phone numbers

Technical Specifications

The input voltage to the 3G4010 can be drawn from the UL/ULC Listed control panel or provided by an external UL/ULC Listed power supply rated for the application (external power-limited source).

NOTE: The power supply must be Class 2, Power Limited. For residential applications a suitable power adaptor is model DSC ADP1310-NAU (for USA) and model DSC ADP1310-NA (for Canada).

Ratings

Power Supply Ratings - Input Voltage (for long-term operation)

CON5-OFF with internal battery: 13.8Vdc required
CON5-ON without internal battery: 13.8Vdc recommended

NOTE: When the input voltage drops below 13.5Vdc, the internal battery supplied with the 3G4010 will not be charged. In order to maintain a charged level for the internal battery, the power supply must have a minimum voltage of 13.5Vdc to ensure a sufficient battery charge in all conditions of use.

Current Consumption

CON5-OFF with internal battery: 120mA*
CON5-ON without internal battery: 500mA*

** Plus any current drawn from the 3G4010 AUX+ terminal*

Working Voltage Range

Battery: sealed, rechargeable type, rated 12V/1.2Ah (for 24hr standby time)
Battery charging voltage: 13.5Vdc
Battery charging current: 50mA

NOTE: Battery must be replaced every 3-5 years.

Operating frequency: 850/1900MHz
Antenna gain: 2.0dBi

Environmental Specifications

Operating temperature: 0°C-49°C (32°F-120°F)
Humidity: 93%RH Maximum (non-condensing)

Mechanical Specifications

Dimensions (metal enclosure, painted): 138mm x 224mm x 55mm / 5.4" x 8.8" x 2.2"
Weight (without battery): 900g / 3.2oz
Internal Event Buffer (communications): 256 Events (not viewable)

Simulated Telco Loop specifications (TIP/RING)

On-Hook Voltage: 35Vdc
Loop Current: 25mA
Loop Resistance 600 Ohms

Alternate construction

Dimensions (enclosure for 3G4010CF): 165mm x 257mm x 76mm / 6.3" x 10.1" x 3"
Weight (alternate construction enclosure without battery): 1300g / 2.8lbs

Identification of Parts

Figure 1 - Parts

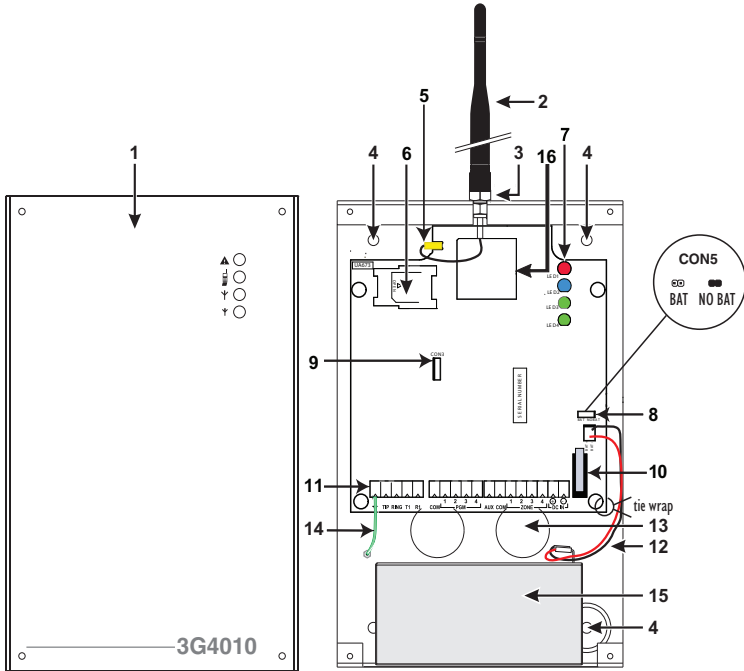

All circuits are classified for UL installations as Power Limited/Class II Power Limited except for the battery leads which are not power limited. Do not route any wiring over circuit boards. Maintain at least 1" (25.4mm) separation. A minimum 1/4" (6.4mm) of separation must be maintained at all points between Power Limited wiring and all other non-Power Limited wiring. Route wires as indicated above.

Table 1: Parts

Parts	
1	Metal Casing
2	3G Antenna
3	Antenna Mounting Hardware
4	Anchor Screw Holes (3mm)
5	Antenna Connector
6	SIM Card Holder
7	Status LEDs (see page 5)
8	CON5 Battery Setting Jumper
9	PC-Link Connector
10	Tamper Switch
11	Terminal Blocks
12	Battery Leads
13	Cable Entry
14	Earth Ground Wire
15	12V/1.2Ah Battery
16	3G (HSPA) Radio Module

This equipment 3G4010 is fixed and shall be installed by Service Persons only (Service Person is defined as a person having the appropriate technical training and experience necessary to be aware of hazards to which that person may be exposed in performing a task, and of measures available to minimize the risks to that person or other persons). It shall be installed and used within an environment that provides the pollution degree max 2, over voltages category II, in non-hazardous, indoor locations only. This manual shall be used with the Installation Manual of the relevant alarm control panel. All instructions specified within that manual must be observed.

Description

This 3G4010 manages transmissions to a central station and can simulate the landline in the event of trouble (e.g., landline down) or even substitute the landline completely in areas where the 3G or 2G wireless service is provided and a landline is not available.

The 3G4010 has the capability of communicating alarm signals via the 3G or 2G data network. This capability ensures a fast, reliable path to central stations equipped with a Sur-Gard System I / II / III / IV receiver. By connecting a 3G4010 to a control panel's standard PSTN interface, telephone-based Contact ID signals are decoded and seamlessly routed through the 3G or 2G network to any of the compatible receiver options.

The performance of the 3G4010 depends greatly on wireless network coverage. Therefore, it should not be mounted without first performing placement tests to determine the best location for reception (minimum of one green LED ON). Optional antenna kits – GS15/25/50-ANT (15ft/4.6m, 25ft/7.6m or 50ft/15.2m) – are available.

The 3G4010 requires enrollment with CONNECT 24 to operate. Dealer application forms and additional information on the CONNECT 24 Voice Response Unit (VRU) and web user interface can be found at www.connect24.com, or at the following telephone numbers:

USA 1-888-251-7458 CANADA 1-888-955-5583

For UL Residential Fire and Burglary installations, the 3G4010 is listed as a sole means of communication or as a back up when used in conjunction with a POTS line (dialer). For UL Residential Fire installations, when installed in the alternate enclosure for 3G4010CF, the 3G4010 has provisions for 24-hour standby power.

For UL Commercial Burglary installations, the 3G4010 is listed as a sole means of communication (supervision window of 200s required at monitoring station) or as a back-up when used in conjunction with a POTS line (dialer).

The 3G4010 shall be powered from any compatible listed control unit or compatible listed power supply that complies with the ratings specified on page 1. The power supply shall be listed for burglary applications and provide a minimum of 4 hours standby power capabilities. An example of a suitable listed compatible control unit is the DSC Model PC1864 with an AUX output rated 11.1 - 12.6VDC. An example of a suitable Listed power supply is DSC Model PC5204 with an AUX output rated 11.6 - 12.6VDC.

For ULC Commercial Fire Monitoring installations the 3G4010 is listed as a passive communication system when used in conjunction with a POTS line (dialer). Fire alarms shall be sent simultaneously over both communication methods (wireless network and PSTN).

For ULC Commercial Burglary installations the 3G4010 is listed as a passive communication system with communication line security level P2 when used as a back up in conjunction with a POTS line (dialer).

For ULC Residential Fire and Burglary installations the 3G4010 is listed as a sole means communication or as a back up when used in conjunction with a POTS line (dialer).

ATTENTION: The 3G4010 is equipped with a current limiter that limits current demand on the 12Vdc power input to 120mA. The current limiter is enabled by default (see Part #8 in 'Identification of Parts' on page 3) with CON5 in the OFF position. The current limiter can be disabled (bypassed) with CON5 in the ON position. When the 3G4010 12Vdc power input is supplied by the Alarm Panel Aux+ output, DSC recommends that the current limiter be active to limit the demand from the panel. If the alarm panel is intended to supply all of the current demand, you must ensure that the panel can supply 500mA and that the current limiter is disabled. When the 3G4010 is transmitting, the current demand exceeds 120mA (500mA). With the current limiter in place, the additional current demand is supplied by the 3G4010 battery.

NOTE: With the current limiter active, there is a risk of discharging the 3G4010 battery when transmission frequency is high. The back up battery must always be connected to the device when the current limiter is enabled.

If power to the 3G4010 is supplied by an external power supply (recommended 13.8 Vdc, 0.7A), the current limiter must be disabled to allow the full current demand to be supplied. In this configuration the 3G4010 battery is not required.

Installing the 3G4010

CONNECT 24 Enrolment Information

Only authorized dealers can enrol a 3G4010 with CONNECT 24. Dealer application forms and additional information on the CONNECT 24 Voice Response Unit (VRU) can be found at the CONNECT 24 website www.connect24.com. Please contact CONNECT 24 at the number below for assistance:

USA 1-888-251-7458 CANADA 1-888-955-5583

NOTE: Step 1 should be performed before turning on the 3G4010 unit.

NOTE: Before inserting or removing the SIM card, please ensure the unit is turned off.

STEP 1 - Initialize the 3G4010 with Connect 24

VRU Enrolment

Call the VRU at the toll-free number: 1-866-910-3865. Follow the voice prompts and enter your profile number, installer ID number, installer PIN number and SIM number. Ensure that all information is available and at hand before calling the VRU. It is recommended that the radio initialization be performed at least 24 hours in advance of installation to ensure SIM activation will be complete.

WEB Enrolment

If you have credentials for www.connect24.com, you may also initialize the 3G4010 via the web. Please check with your Connect 24 Master Reseller or Connect 24 Customer Service for more details.

STEP 2 - Determine the Best Signal Location

1. Unscrew the four screws securing the front panel to the cabinet. Remove the front panel.
2. Fit the 3G antenna [2]. Ensure the 3G antenna mounting hardware is fastened securely [3].
3. Attach the 3G radio module with the 3G antenna connector. Ensure that the connector is secure.
4. Turn on the 3G4010 and check the signal strength.
 - 4.1 Connect the battery to the RED and BLK battery leads.
 - 4.2 Connect the DC power source to +/- 12V terminals.
5. Allow the unit to power up.

NOTE: The green LEDs will indicate the signal strength. The bottom green LED must be **ON** for the location to be acceptable. Please refer to the 'Status LEDs' section for more information.

6. Power down the 3G4010 by removing the DC power source and battery leads.

STEP 3 - Connect the 3G4010

1. Using the cabinet, mark the four screw locations. Drill the anchor screw holes.

NOTE: Check for cable conduits and water pipes before drilling.

2. Using anchor screws (not provided), mount the cabinet to the wall.
3. Run the cables through the cable entry [13] or through the cabinet knockouts.
4. Complete the connections on the terminal blocks [11].

NOTE: Ensure that power and Telco circuit connections are made only after the cabinet has been secured to the building or structure, and has been connected to the protective earth ground. Descriptions of the terminals can be found in the 'Connecting the 3G4010' section.

5. Reattach the front cover [1] securely to the cabinet.

NOTE: Please refer to Figure 2 at the end of this manual for wiring diagram.

Connecting the 3G4010

⏚ (1) Earth Ground - This terminal must be connected to the Mains Earth, in order to comply with the Telecommunications Network Safety Standards (Overvoltage Protection Requirements).

TIP (2) / RNG (3) External Telephone Line - These terminals must be connected directly to the incoming telephone line.

T1 (4) / R1 (5) Internal Telephone Line - These terminals must be connected to the TIP and RING of the control panel.

COM (6,14) Common - This terminal is connected internally to Power Ground.

PGM1 (7), PGM2 (8), PGM3 (9), PGM4 (10) Programmable Open-collector Outputs - These outputs can be activated by programmed events. Refer to 'Activating the Outputs' for details. The maximum current sink of each output must not exceed 50mA.

AUX+ (11) Auxiliary 12V Output - +12V Output, 200mA PTC Protected.

NOTE: Electrical current drawn from this terminal is drawn directly from the power supply. This

must be added to the 3G4010 current when determining the total draw on the host panel or power supply. Jumper CON5 does not limit the electrical current available on this output.

Tamper (12-13) - These terminals are connected in series to the Tamper switch [10]. They will close when the cabinet is properly closed, and will open when the front cover is removed.

Z1-Z4 (15-16-17-18) Programmable Inputs - These terminals can be set up to trigger events. Refer to 'Inputs' for details.

12V (19), COM (20) Device Power Supply - These terminals must be connected to a rated power supply. Once the connections are completed, connect the battery leads (Red and Black wires, [12] in Figure 1) to a 12V, 7Ah battery.

Jumper CON5

CON5 ON - Full power, including standby capacity, comes from the host panel or external power supply. Supply must be capable of up to 700mA. The 3G4010 battery must *not* be connected.

CON5 OFF - Current limiting mode, the host panel or external supply provides standby current.

Supply must be capable of 120mA plus any current drawn from AUX+ terminal. 3G4010 battery must be installed for proper operation.

NOTE: The power supply must have a minimum voltage of 13.5V to ensure a sufficient battery charge. An example of a suitable power supply is the DSC Model ADP1310-NA with DC output rated 13.8 VDC, 1Amp. This is to be used in conjunction with a 12V/7Ah rated battery for UL/ULC listed residential installations.

NOTE: This mode of operation must not be used for ULC Listed Fire Monitoring installations.

NOTE: When disposing of batteries, follow the instructions and precautions printed on the batteries, and contact your municipal offices for information on the disposal of used batteries.

Status LEDs

The 3G4010 interface has four status LEDs. The following describes the control panel status LEDs.

NOTE: The top two LEDs blink during the Initializing and Programming phases.

▲ RED - This LED is normally Off; but, it will flash in the event of a trouble. This LED will switch on within three minutes in the event of wireless Module [16] trouble, or when the wireless Network is unavailable, 'No Service'. If this LED flashes, the following list indicates the specific trouble based on the number of flashes, by priority. When turned on, the 3G4010 checks for the trouble conditions to be restored in the order listed below. The 3G4010 indicates the status of the highest priority, unrestored trouble condition with the corresponding number of flashes of the red LED. Once the highest priority trouble condition has been cleared, the next highest priority trouble condition is displayed (if applicable).

1 flash - Battery Trouble (Battery with low voltage output)

2 flashes - Radio/SIM Trouble (Battery absent or SIM Card disconnected)

3 flashes - Wireless Network Problem (SIM not active, poor signal strength, antenna not connected)

4 flashes - Insufficient Signal Strength (poor location)

5 flashes - Connect 24 Configuration SMS Trouble (Improper VRU programming. Once the configuration is ready, turn off power for 2-3 seconds to allow the unit to restart and request again)

6 flashes - Receiver not available (Improper VRU programming, receiver absent)

7 flashes - Power Supply Trouble (DC power supply absent)

Off - No Troubles



YELLOW - When this LED is On (solid), a Phone Line Trouble condition exists. This LED switches on when the interface switches to the Wireless Network (due to a Landline trouble condition).



This LED flashes slowly in the event of an incoming or outgoing voice call (regardless of the operating status of the landline). This LED can also flash quickly once (Wireless TX) or twice (Wireless RX).



GREEN (Top) - When this LED is On, the reception is optimal. This LED switches On only when the other Green LED is on.



GREEN (Bottom) - If this LED is Off and the Red LED is On, the Wireless Network service is unavailable (NO SERVICE). This LED flashes when the Wireless Network reception is poor. If this LED is on, the 3G4010 is able to communicate with the 3G (HSPA) or 2G (GPRS) network.

Operating Principles

Simulated Landline Mode

The simulated landline provides the alarm control panel (with dialer interface) with a back up line in the event of PSTN line trouble. If the voltage on the landline terminals (TIP/RNG) drops below 2.8V for a period of between 10 seconds and 45 seconds - depending on the device connected to the T1/R1 terminals- the 3G4010 switches the connected telephone device to the wireless network. After waiting between 30 and 40 seconds, it checks the landline for one of the following:

- If the landline has been restored, the 3G4010 switches the connected device back to the landline, OR
- If the landline is still down, the 3G4010 continues the simulation until the landline is restored. The 3G4010 will not switch during ongoing calls.

NOTE: When the landline is down, the 3G4010 provides a dial tone to any device connected to T1 and R1, including any telephones on the premises. The phones on the premises will not, however, be able to dial out over the 3G4010.

Panel Transmission Monitoring (PTM)

The 3G4010 can also monitor the panel's attempt to communicate with the central station. If it determines that the panel is having difficulty, it switches the line to the wireless network. This feature is only active when the 3G4010 is configured as a back up communicator. This feature is in addition to the regular line voltage detection.

The 3G4010 monitors the phone line for four consecutive failed attempts within a 12-minute window. A failed attempt is assumed to have occurred when a line seizure takes place during dialing (either the alarm panel or the customer telephone), but no 1400Hz tone (or Contact Kiss-off) is sent from the receiver. Once the conditions for a failed attempt are met, the 3G4010 connects the panel to the wireless network to communicate the events. When the 3G4010 switches the line it stays in this mode until the panel hangs up. On the next event the 3G4010 restarts the error detection sequence before switching. The 3G4010 performs this sequence on any phone number that is detected on the line. Specific central station phone numbers can be programmed into the 3G4010 if desired. Up to four, 20-digit numbers can be added to your profile at Connect 24. If programmed, the 3G4010 will only look for Contact ID Kiss-off after these numbers are dialed. A Telephone Line Monitoring trouble (PGM output activation and/or reporting code if applicable) is also activated and/or transmitted when the PTM is activated. A restoral is sent at the end of the call.

Wireless Communications Sequence

- When an alarm is triggered, the control panel goes off-hook.
- The 3G4010 asserts a dial tone.
- The Control panel dials the number of the central station. Ensure that the alarm panel inserts a minimum one second pause, or has Dial Tone Search enabled before dialing the number.
- The 3G4010 detects the DTMF dialing and stops dial tone.

NOTE: The 3G4010 is unable to decode pulse dialing.

- The 3G4010 sends the required Contact ID dual-tone handshake to the panel.
- After receiving the handshake, the control panel transmits an alarm message in Contact ID format.
- The 3G4010 decodes and transforms the Contact ID digits into an IP packet and sends it to the central station receiver over the wireless network.
- The central station receiver acknowledges the alarm and sends a command to the 3G4010 to generate the corresponding 1400Hz Kiss-off signal for a minimum of 800msec.

After the 3G4010 generates a Kiss-off signal, it sends the next alarm or, if no further alarms need to be sent, the control panel goes on-hook.

Inputs

The 3G4010 has four inputs that can be used to trigger specific communications. These events will transmit using Contact ID format with Inputs 1-4 reporting as [991] to [994] respectively.

Default settings are:

INPUT 1 - FIRE	INPUT 3 - BURGLARY
INPUT 2 - PANIC ALARM	INPUT 4 - SYSTEM TROUBLE

These inputs are normally open and will activate when a short condition is detected between the terminal and the COM. Refer to the 3G4010 Wiring Diagram (Figure 2) at the back of this manual.

NOTE: These inputs communicate using Contact ID format.

NOTE: For UL/JULC installations, connections between alarm panel outputs and 3G4010 inputs must be run in protective mechanical conduits. To reduce interference with the antenna, it is recommended that the metal conduit is not connected to the knock-outs in the top of the cabinet.

Outputs

The 3G4010 has four programmable outputs to activate in response to the associated events. Refer to the 3G4010 Wiring Diagram (Figure 2) at the back of this manual.

Activating the Outputs

The 3G4010 has four open collector outputs capable of a maximum of 50mA. Internal events on the 3G4010 can trigger the outputs to turn on an LED or activate an input on the host panel. The default settings are as follows.

OUTPUT 1 Landline Trouble - Output is normally high and will switch to ground when the telephone line is down.

OUTPUT 2 Wireless Module or Network Trouble - Output is normally high and will switch to ground when the 3G4010 can not communicate with the 3G or 2G network.

OUTPUT 3 Power Supply or Battery Trouble - Output is normally high and will switch to ground when there is a problem with the power source.

OUTPUT 4 General Module Trouble - Output is normally low and will switch to high when a Wireless Network Trouble, Power Supply/Battery Trouble, and/or a Failure to Communicate (FTC) trouble is detected.

NOTE: PGM4 must be connected to the control panel as shown in Figure 4 (Residential applications) or Figures 8-9 (Commercial applications). Program the control panel input Zone/Point as 24hr 'Supervisory' with keypad-only notification when activated. Output 4 on the 3G4010 must be set as 'Active High'.

NOTE: Once an output has been activated automatically, it will not restore its state until all the causes of activation are cleared.

Contact ID

Events Description

Event Codes

INPUT 1 ACTIVATION:	E110 FIRE ZONE 001 991
INPUT 1 RESTORAL:	R110 FIRE ZONE 001 991
INPUT 2 ACTIVATION:	E120 PANIC ALARM ZONE 002 992
INPUT 2 RESTORAL:	R120 PANIC ALARM ZONE 002 992
INPUT 3 ACTIVATION:	E130 BURGLARY ZONE 003 993
INPUT 3 RESTORAL:	R130 BURGLARY ZONE 003 993
INPUT 4 ACTIVATION:	E300 SYSTEM TROUBLE ZONE 004 994
INPUT 4 RESTORAL:	R300 SYSTEM TROUBLE ZONE 004 994
PSTN LINE DOWN:	E351 TELCO 1 FAULT 000
PSTN LINE RESTORAL:	R351 TELCO 1 FAULT 000
12V INPUT LOSS:	E337 EXP. MOD. DC LOSS 000
12V INPUT RESTORAL:	R337 EXP. MOD. DC LOSS 000
LOW BATTERY ALERT:	E338 EXP. MOD. LOW BAT 000
LOW BATTERY RESTORAL:	R338 EXP. MOD. LOW BAT 000
PERIODIC REPORT:	E603 PERIODIC RF XMISSION 000
PERIODIC REPORT WITH OFF-NORMAL CONDITION:	E608 PERIODIC TEST XMISSION SYSTEM TROUBLE PRESENT 000
3G UNIT ACTIVATION:	R552 RADIO XMITTER DISABLED 000
UNIT INTERNAL BUFFER FULL:	E624 EVENT LOG OVERFLOW 000
FTC RESTORAL:	R354 FAILURE TO COMMUNICATE 000

Swinger Shutdown

Swinger Shutdown is followed by a PSTN line trouble, limiting this event to a maximum of 3 trouble reports every 24 hours (including the PSTN line trouble sent when PTM is active). The condition will restore at midnight at which point the counter is reset.

Hardware Default

To perform a hardware default and force the unit to get the latest configuration from Connect 24, follow these steps:

- Power down the unit.
- Place a short between the PGM1 and Input 1 terminals.
- Power up the unit. This will perform a hardware default and request the configuration from Connect 24.
- Remove the short between PGM1 and Input 1.

NOTE: If the unit has previously received programming from Connect 24, a hardware default is required to initiate the download of the latest configuration from Connect 24. Failure to do so will result in the unit transmitting with the previously programmed configuration.

NOTE: A Hardware default must be performed when the SIM card is being swapped.

Low Power Radio Shutdown

When the battery voltage reaches the low battery threshold of 10.5V, the unit turns off the radio to prevent unnecessary network registrations. In this state, the unit does not communicate any events.

Radio shutdown is indicated by the LEDs as follows:

- for 1 second -- red is on, yellow is off, green 1 is off, and green 2 is off.

- for 1 second -- red is off, yellow is on, green 1 is on, and green 2 is on.

This LED sequence will continue to be displayed until the low battery voltage is restored and the radio enabled again.

Connect 24 Remote Programming

The inputs, outputs, and other features can be remotely programmed through Connect 24 for fast and convenient installation using the Internet.

NOTE: This programming option has not been investigated by UL.

Troubleshooting Guide

Powering up the 3G4010 – when powering up the 3G4010, always connect the battery first before connecting primary DC power from the control panel or transformer.

Wiring Primary – R-1/T-1 of 3G4010 to RING/TIP of control panel, DC power from control panel or DC transformer to DC input, backup battery if CON5 OFF.

Wiring Backup – Incoming line to RING/TIP on 3G4010, R-1/T-1 of 3G4010 to RING/TIP of control panel, R-1/T-1 of control panel to house phones, DC power from control panel or DC transformer to DC input, backup battery if CON5 OFF.

Testing Communications – when the 3G4010 transmits a signal for the control panel, or for an internal transmission, the YELLOW light will flash one time when the signal is transmitted and two times when it gets a kiss-off.

SIM – the SIM should be activated at least 24 hours prior to installation. The 3G4010 will show signal strength with an inactive SIM, however it will display the signal strength of any available wireless network. The SIM must be active to ensure the signal strength displayed is that of the wireless network provider for which the SIM belongs to.

Panel Programming – the control panel should be programmed to communicate Contact ID exactly the same way it would be programmed to communicate Contact ID over the telephone line.

Green Light Status	What it means:	Signal Strength Status
Both Green Lights ON	Excellent Signal Strength	<ul style="list-style-type: none"> • Unit can be installed in the current mounting location
One Green Light ON	Good Signal Strength	<ul style="list-style-type: none"> • Unit can be installed in the current mounting location
Bottom Green Light FLASHING	Poor Signal Strength	<ul style="list-style-type: none"> • Ensure the antenna cable is plugged securely into the radio connector • If the SIM is active, connect a battery to the unit and test various locations for good/excellent signal strength • Connect an antenna extension kit (GS-15ANT, GS-25ANT or GS-50ANT)

Both Green Lights OFF	No Signal Strength	<ul style="list-style-type: none"> • If the red light is also FLASHING, refer to the RED light chart • Verify SIM card is activated • Ensure the antenna cable is plugged securely into the radio connector • If the SIM is active, connect a battery to the unit and test various locations for good/excellent signal strength • Connect an antenna extension kit (GS-15ANT, GS-25ANT or GS-50ANT)
---------------------------------	--------------------	--

Yellow Light Status	What It Means: Wireless Communicator Status/Communication Indicator
Yellow Light ON	<ul style="list-style-type: none"> • When used as the primary communicator, the yellow light will always be ON. • When used as a backup communicator, the yellow light will be ON when there is a no phone line connected to the 3G4010 TIP and RING, or the line voltage goes below 2.8VDC.
Yellow Light OFF	<ul style="list-style-type: none"> • Indicates a good phone line is connected to the 3G4010. (more than 2.8 VDC detected across the 3G4010 TIP and RING terminals).
Yellow Light FLASHING	<ul style="list-style-type: none"> • The yellow light will flash one time when the 3G4010 transmits a signal and two times when a kiss-off is received.

Red Light Status	What it means: Trouble Status	Trouble Status - Troubleshooting Steps
One Flash	3G4010 Low Battery	<ul style="list-style-type: none"> • Measure the battery under load and verify it is charged to at least 12.5 VDC. If not, wait at least 1 hour for the battery to charge • Remove the battery and measure the voltage across the two battery leads; the voltage should be at least 13.5 VDC • Verify the input DC supply is rated at 13.8VDC @ 120mA minimum • Ensure the 3G4010 jumper J3 is OFF
Two Flashes	SIM/Radio Trouble	<ul style="list-style-type: none"> • Ensure the SIM Card is inserted correctly and firmly • Ensure the antenna cable is plugged securely into the radio connector • Ensure the power source connected to the 3G4010 is providing 13.8VDC @ 120mA and that the battery is fully charged
Three Flashes	Wireless Network Problem	<ul style="list-style-type: none"> • Ensure the SIM card has been activated • The antenna cable should be plugged securely into the radio connector • Ensure there is good signal strength (at least one green light ON) • Verify the installation area is not experiencing a network outage
Four Flashes	Insufficient Signal Strength	<ul style="list-style-type: none"> • Ensure there is good signal strength (at least one 3G4010 green light ON) • Ensure the antenna cable is plugged securely into the radio connector
Five Flashes	Configuration Trouble	<ul style="list-style-type: none"> • Ensure the SIM card is activated

Six Flashes	Receiver Not Available	<ul style="list-style-type: none">• Contact the monitoring station to verify that the 3G4010 programming is correct (port, IP address, DNIS)• Contact your central station to verify they are not experiencing any receiver issues
Seven Flashes	DC Supply Trouble	<ul style="list-style-type: none">• Ensure the power source connected to the 3G4010 is providing 13.8VDC @ 120mA

The Red light will flash to indicate various trouble conditions outlined previously. If multiple trouble conditions are present, the red light will flash according to the highest priority trouble. For example, if both a 3G4010 low battery trouble (one flash) and an insufficient signal strength trouble (four flashes) are present; the red light will flash one time. Once the 3G4010 low battery trouble condition is corrected, the red light will then begin flashing four times.

General Troubles With Your System	
The control panel is displaying a telephone line trouble condition	<ul style="list-style-type: none"> • Ensure T1 and R1 of the 3G4010 are wired to the TIP and RING terminals of the control panel • If the 3G4010 is being used as the primary communicator, the yellow light will always be ON • If the 3G4010 red light is FLASHING, refer to the Red Light Status Chart
The control panel displays a communication trouble condition	<ul style="list-style-type: none"> • Ensure the panel is programmed for Contact ID • Ensure the control panel does not indicate a TLM trouble condition • If the 3G4010 red light is FLASHING refer to the Red Light Status chart in this guide
No signals are received at the central station but no trouble condition is displayed	<ul style="list-style-type: none"> • Ensure the control panel has a central station phone number programmed • Ensure the control panel has the correct account number programmed • Verify the reporting codes are programmed or the auto Contact ID option is enabled • Ensure the control panel communicator is enabled • Connect a handset to T1 and R1 of the 3G4010 in monitor mode to verify the control panel is trying to communicate
Not receiving internal signals generated directly from the 3G4010	<ul style="list-style-type: none"> • Ensure the 3G4010 was initialized with the correct account number. This can be checked by logging into the Connect 24 website • Ensure that there are no trouble conditions on the 3G4010
The 3G4010 Yellow and Red lights flash constantly	<ul style="list-style-type: none"> • Ensure there is good signal strength (at least one 3G4010 green light ON) • Ensure the SIM card is activated. Depending on signal strength and network activity it can take up to 10 minutes for the network to program the unit; wait at least 15 minutes for the programming to be completed • Cycle power and verify SIM and signal
The phone line is seized when the 3G4010 is connected	<ul style="list-style-type: none"> • Verify correct phone line wiring • Ensure the Ringer Equivalency Number (REN) is not being exceeded on the line

General Information	
Removing/Connecting the antenna	<ul style="list-style-type: none"> • To remove the antenna from the 3G4010, place your thumb on the end of the connector at the modem, then place a screwdriver between the modem and connector. Gently turn the screwdriver away to 'pop' out the connector from the modem • To install the antenna, firmly push the connector into the modem until it 'snaps' into place

General Information

Enrolling a 3G4010	<ul style="list-style-type: none"> • The 3G4010 can be enrolled by going through the GVRU voice prompt, and completing the activation of the SIM card, and the initialization of the 3G4010 • The 3G4010 can also be enrolled using the Connect 24 website (www.connect24.com)
SIM card activation period	<ul style="list-style-type: none"> • A SIM card can take up to 24 hours to be activated by the provider. However, it typically takes less than an hour for the SIM card to be activated
Checking SIM status	<ul style="list-style-type: none"> • Go to www.connect24.com and login. A search can be performed for a specific account and its current status • SIM status can also be checked through the GVRU
Critical Shutdown on 3G4010 backup battery	<ul style="list-style-type: none"> • If the 3G4010 backup battery is used and is below 10.5VDC, the unit will go into critical shutdown • The critical shutdown state will be displayed by the red light flashing followed by the yellow and two green lights flashing • The lights will continue to flash in this sequence until the battery is charged above 12.4VDC
Swinger Shutdown for Telephone Line Monitor (TLM) transmissions for backup units	<ul style="list-style-type: none"> • If the 3G4010 is configured as a backup, it can send a maximum of 3 TLM troubles and restorals per day • TLM Swinger Shutdown only affects signal transmissions, not the functionality of the 3G4010 lights or PGM outputs
Critical Shutdown on 3G4010 backup battery	<ul style="list-style-type: none"> • If the 3G4010 backup battery is used and is below 10.5VDC, the unit will go into critical shutdown • The critical shutdown state will be displayed by the red light flashing followed by the yellow and two green lights flashing • The lights will continue to flash in this sequence until the battery is charged above 12.4VDC
Swinger Shutdown for Telephone Line Monitor (TLM) transmissions for backup units	<ul style="list-style-type: none"> • If the 3G4010 is configured as a backup, it can send a maximum of 3 TLM troubles and restorals per day • TLM Swinger Shutdown only affects signal transmissions, not the functionality of the 3G4010 lights or PGM outputs

3G4010 Wiring Diagrams

Figure 2 - Wiring Diagram

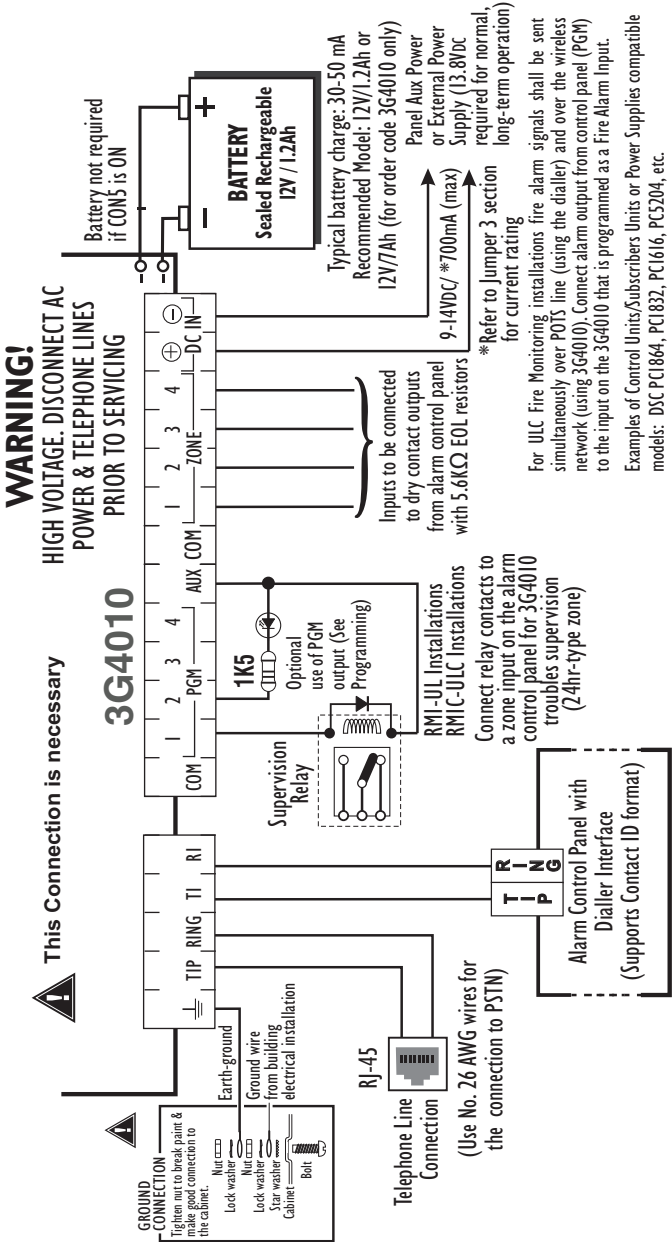

WARNING: Incorrect connections may result in PTC failure or improper operation. Inspect wiring and ensure connections are correct before turning on. All circuits are classified for UL installations as Power Limited/Class II Power Limited except for the battery leads which are not Power Limited. Do not route any wiring over circuit boards. Maintain at least 1" (25.4mm) separation. A minimum 1/4" (6.4mm) separation must be maintained at all points between Power Limited wiring and all other Non-Power Limited wiring. Route wires as indicated in the diagram.

NOTE: For ULC Commercial Fire and Burglary Installation requirements please refer to Figures 5, 6, 7 & 8 and to the ULC Installation Guide P/N 2900215TR009.

3G4010 Wiring Diagrams

Figure 3 - Telephone Connection

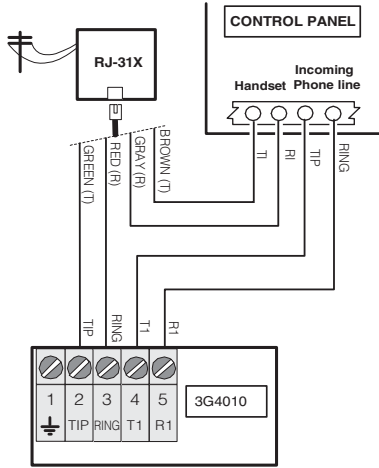
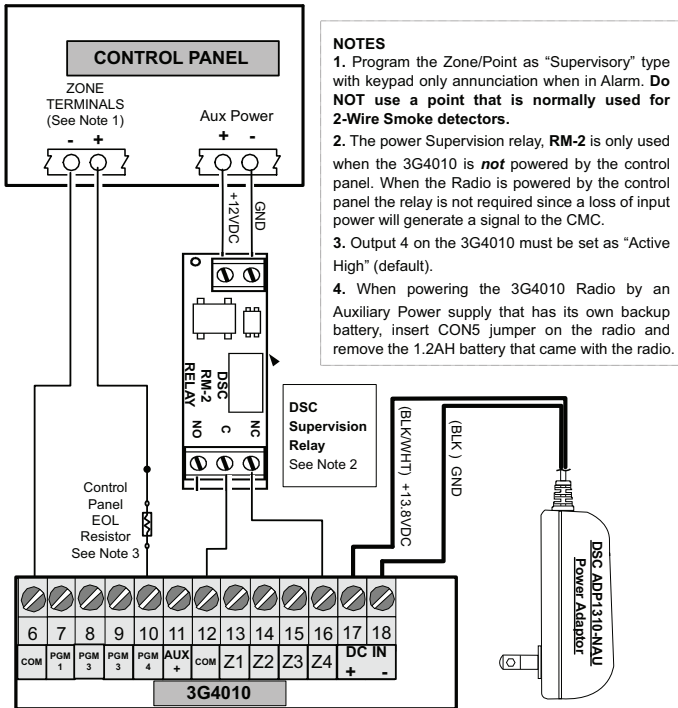

Figure 4 - Power Supply and Supervision Wiring Diagram



The following wiring diagrams (Figures 5 to 8) are examples of ULC Listed Fire Monitoring Installation connections.

3G4010 Wiring Diagrams

Figure 5 - Fire Alarm Control Unit and 3G Transmitter

Wiring Diagram for Fire Alarm Control Unit (with dialler) and 3G (HSPA/2G (GPRS) Transmitter (Passive Communication System)

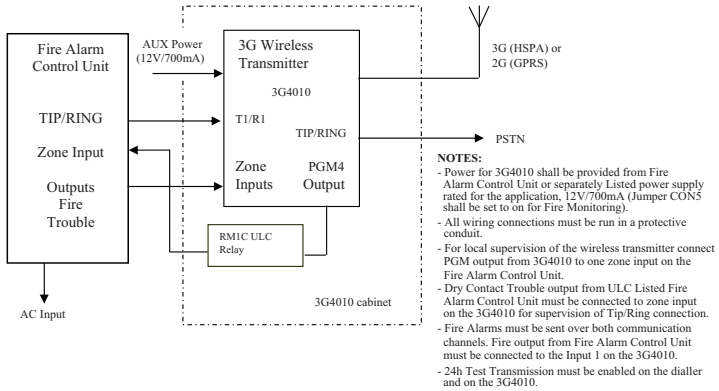
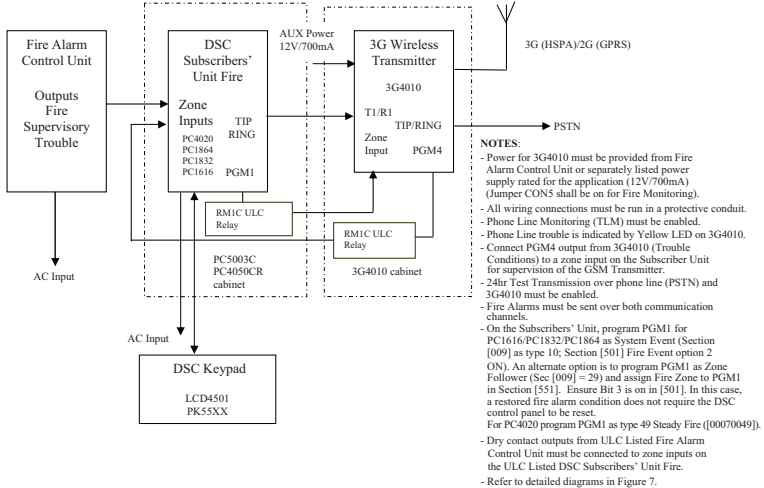

Figure 6 - DSC Subscribers' Unit Fire and 3G Transmitter Mounted in the Same Room

Wiring Diagram for DSC Subscribers' Unit Fire and 3G Transmitter (Passive Communication System)



3G4010 Wiring Diagrams

Figure 7 - DSC Subscribers' Unit Fire and 3G Wireless Transmitter Mounted Remotely

**Alternate Wiring Diagram for DSC Subscribers' Unit Fire and wireless Transmitter
Passive Communication System -Using Phone Line Supervision Relay**

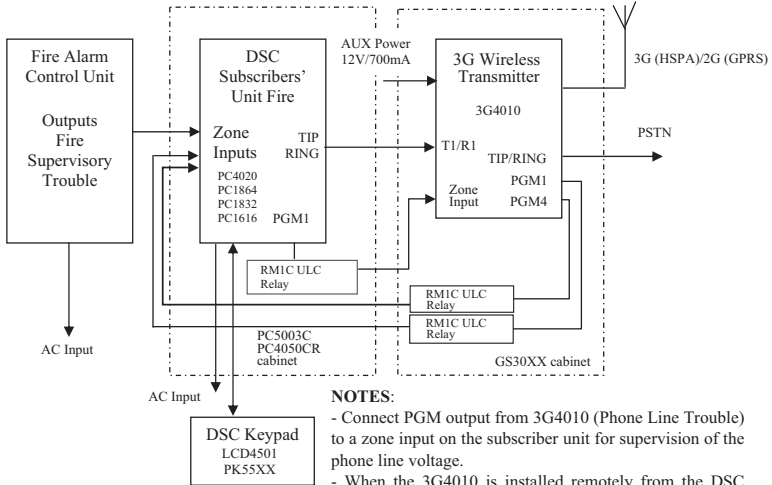

- NOTES:**
- Connect PGM output from 3G4010 (Phone Line Trouble) to a zone input on the subscriber unit for supervision of the phone line voltage.
 - When the 3G4010 is installed remotely from the DSC Control Panel, it is required to monitor the Phone Line Trouble condition at the keypad by using an additional RM1C Relay.
 - Refer to detailed diagrams in Figure 8.

**PLEASE NOTE THAT EITHER RM1C ULC OR RM2 RELAYS
CAN BE USED FOR ULC INSTALLATIONS**

3G4010 Wiring Diagrams

Figure 8 -Connection Details for Wireless Network Supervision Relay and Redundant Fire Alarm Transmission

Connection Details for Wireless Network Supervision Relay & Redundant Fire Alarm Transmission

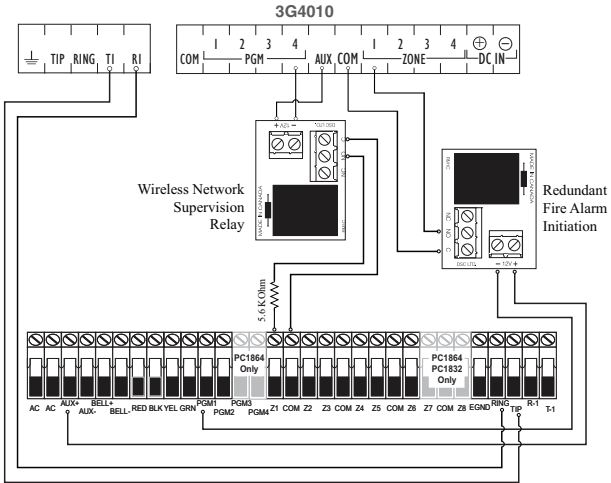

Connection Details for wireless network Supervision Relay & Redundant Fire Alarm Transmission

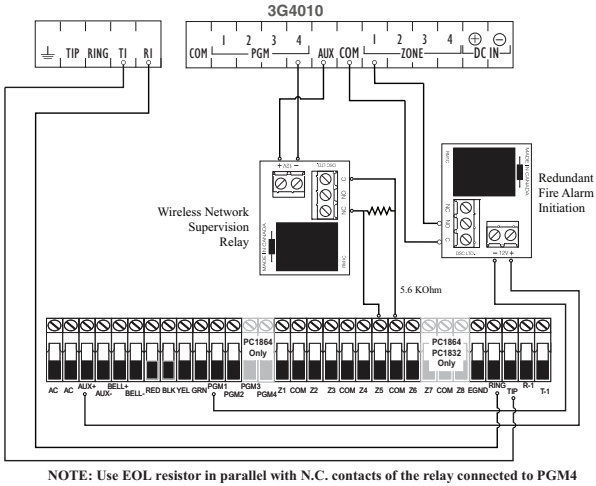

3G4010 Wiring Diagrams

Figure 9 - Connection Details for GSM Supervision Relay, Phone Line Supervision and Redundant Fire Alarm Transmission

Connection Details for Wireless Network Supervision Relay, Phone Line Supervision Relay and Redundant Fire Alarm Transmission

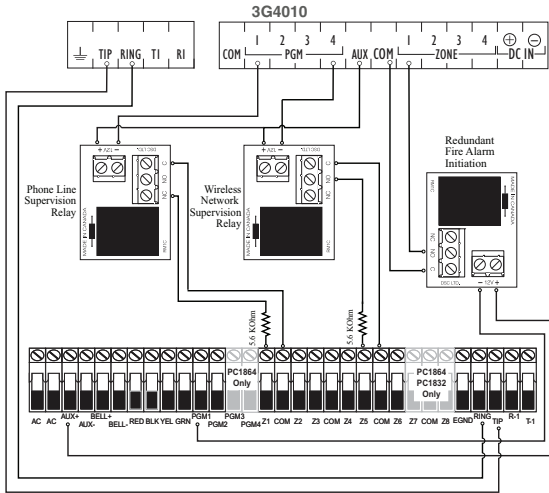

NOTE: Use EOL resistor in series with N.O. contacts of the relay connected to PGM4

Connection Details for Wireless Network Supervision Relay, Phone Line Supervision Relay and Redundant Fire Alarm Transmission

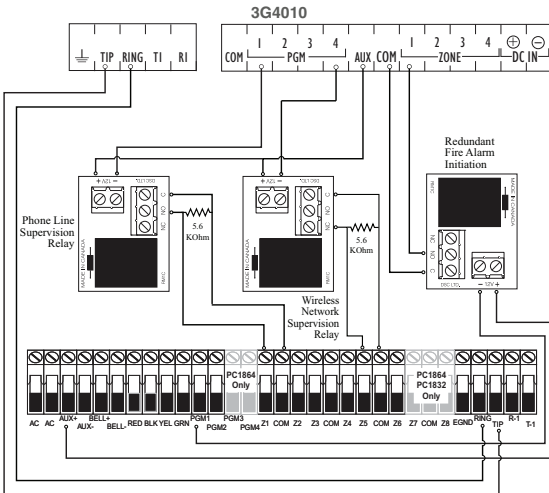

NOTE: Use EOL resistor in parallel with N.C. contacts of the relay connected to PGM4

IMPORTANT READ CAREFULLY: DSC Software purchased with or without Products and Components is copyrighted and is purchased under the following license terms:

- This End User License Agreement ("EULA") is a legal agreement between You (the company, individual or entity who acquired the Software and any related Hardware) and Digital Security Controls, a division of Tyco Safety Products Canada Ltd. ("DSC"), the manufacturer of the integrated security systems and the developer of the software and any related products or components ("HARDWARE") which You acquired.
- If the DSC software product ("SOFTWARE PRODUCT" or "SOFTWARE") is intended to be accompanied by HARDWARE, and is NOT accompanied by new HARDWARE, You may not use, copy or install the SOFTWARE PRODUCT. The SOFTWARE PRODUCT includes computer software, and may include associated media, printed materials, and "online" or electronic documentation.
- Any software provided along with the SOFTWARE PRODUCT that is associated with a separate end user license agreement is licensed to You under the terms of that license agreement.
- By installing, copying, downloading, storing, accessing or otherwise using the SOFTWARE PRODUCT, You agree unconditionally to be bound by the terms of this EULA, even if this EULA is deemed to be a modification of any previous arrangement or contract. If you do not agree to the terms of this EULA, DSC is unwilling to license the SOFTWARE PRODUCT to You, and You have no right to use it.

SOFTWARE PRODUCT LICENSE

The SOFTWARE PRODUCT is protected by copyright laws and international copyright treaties, as well as other intellectual property laws and treaties. The SOFTWARE PRODUCT is licensed, not sold.

1. GRANT OF LICENSE. This EULA grants You the following rights:

- (a) Software Installation and Use - For each license You acquire, You may have only one copy of the SOFTWARE PRODUCT installed.
- (b) Storage/Network Use - The SOFTWARE PRODUCT may not be installed, accessed, displayed, run, shared or used concurrently on or from different computers, including a workstation, terminal or other digital electronic device ("Device"). In other words, if You have several workstations, You will have to acquire a license for each workstation where the SOFTWARE will be used.
- (c) Backup Copy - You may make back up copies of the SOFTWARE PRODUCT, but You may only have one copy per license installed at any given time. You may use the back up copy solely for archival purposes. Except as expressly provided in this EULA, You may not otherwise make copies of the SOFTWARE PRODUCT, including the printed materials accompanying the SOFTWARE.

2. DESCRIPTION OF OTHER RIGHTS AND LIMITATIONS

- (a) Limitations on Reverse Engineering, Decompilation and Disassembly - You may not reverse engineer, decompile, or disassemble the SOFTWARE PRODUCT, except and only to the extent that such activity is expressly permitted by applicable law notwithstanding this limitation. You may not make any changes or modifications to the Software, without the written permission of an officer of DSC. You may not remove any proprietary notices, marks or labels from the Software Product. You shall institute reasonable measures to ensure compliance with the terms and conditions of this EULA.
- (b) Separation of Components - The SOFTWARE PRODUCT is licensed as a single product. Its component parts may not be separated for use on more than one HARDWARE unit.
- (c) Single INTEGRATED PRODUCT - If You acquired this SOFTWARE with HARDWARE, then the SOFTWARE PRODUCT is licensed with the HARDWARE as a single integrated product. In this case, the SOFTWARE PRODUCT may only be used with the HARDWARE as set forth in this EULA.
- (d) Rental - You may not rent, lease or lend the SOFTWARE PRODUCT. You may not make it available to others or post it on a server or web site.
- (e) Software Product Transfer - You may transfer all of Your rights under this EULA only as part of a permanent sale or transfer of the HARDWARE, provided You retain no copies, You transfer all of the SOFTWARE PRODUCT (including all component parts, the media and printed materials, any upgrades and this EULA), and provided the recipient agrees to the terms of this EULA. If the SOFTWARE PRODUCT is an upgrade, any transfer must also include all prior versions of the SOFTWARE PRODUCT.
- (f) Termination - Without prejudice to any other rights, DSC may terminate this EULA if You fail to comply with the terms and conditions of this EULA. In such event, You must destroy all copies of the SOFTWARE PRODUCT and all of its component parts.
- (g) Trademarks - This EULA does not grant You any rights in connection with any trademarks or service marks of DSC or its suppliers.

3. COPYRIGHT

All title and intellectual property rights in and to the SOFTWARE PRODUCT (including but not limited to any images, photographs, and text incorporated into the SOFTWARE PRODUCT), the accompanying printed materials, and any copies of the SOFTWARE PRODUCT, are owned by DSC or its suppliers. You may not copy the printed materials accompanying the SOFTWARE PRODUCT. All title and intellectual property rights in and to the content which may be accessed through use of the SOFTWARE PRODUCT are the property of the respective content owner and may be protected by applicable copyright or other intellectual property laws and treaties. This EULA grants You no rights to use such content. All rights not expressly granted under this EULA are reserved by DSC and its suppliers.

4. EXPORT RESTRICTIONS

You agree that You will not export or re export the SOFTWARE PRODUCT to any country, person, or entity subject to Canadian export restrictions.

5. CHOICE OF LAW: This Software License Agreement is governed by the laws of the Province of Ontario, Canada.

6. ARBITRATION

All disputes arising in connection with this Agreement shall be determined by final and binding arbitration in accordance with the Arbitration Act, and the parties agree to be bound by the arbitrator's decision. The place of arbitration shall be Toronto, Canada, and the language of the arbitration shall be English.

7. LIMITED WARRANTY

(a) NO WARRANTY

DSC PROVIDES THE SOFTWARE "AS IS" WITHOUT WARRANTY. DSC DOES NOT WARRANT THAT THE SOFTWARE WILL MEET YOUR REQUIREMENTS OR THAT OPERATION OF THE SOFTWARE WILL BE UNINTERRUPTED OR ERROR-FREE.

(b) CHANGES IN OPERATING ENVIRONMENT

DSC shall not be responsible for problems caused by changes in the operating characteristics of the HARDWARE, or for problems in the interaction of the SOFTWARE PRODUCT with non-DSC-SOFTWARE or HARDWARE PRODUCTS.

(c) LIMITATION OF LIABILITY; WARRANTY REFLECTS ALLOCATION OF RISK

IN ANY EVENT, IF ANY STATUTE IMPLIES WARRANTIES OR CONDITIONS NOT STATED IN THIS LICENSE AGREEMENT, DSC'S ENTIRE LIABILITY UNDER ANY PROVISION OF THIS LICENSE AGREEMENT SHALL BE LIMITED TO THE GREATER OF THE AMOUNT ACTUALLY PAID BY YOU TO LICENSE THE SOFTWARE PRODUCT AND FIVE CANADIAN DOLLARS (CAD\$5.00). BECAUSE SOME JURISDICTIONS DO NOT ALLOW THE EXCLUSION OR LIMITATION OF LIABILITY FOR CONSEQUENTIAL OR INCIDENTAL DAMAGES, THE ABOVE LIMITATION MAY NOT APPLY TO YOU.

(d) DISCLAIMER OF WARRANTIES

THIS WARRANTY CONTAINS THE ENTIRE WARRANTY AND SHALL BE IN LIEU OF ANY AND ALL OTHER WARRANTIES, WHETHER EXPRESSED OR IMPLIED (INCLUDING ALL IMPLIED WARRANTIES OF MERCHANTABILITY OR FITNESS FOR A PARTICULAR PURPOSE) AND OF ALL OTHER OBLIGATIONS OR LIABILITIES ON THE PART OF DSC. DSC MAKES NO OTHER WARRANTIES. DSC NEITHER ASSUMES NOR AUTHORIZES ANY OTHER PERSON PURPORTING TO ACT ON ITS BEHALF TO MODIFY OR TO CHANGE THIS WARRANTY, NOR TO ASSUME FOR IT ANY OTHER WARRANTY OR LIABILITY CONCERNING THIS SOFTWARE PRODUCT.

(e) EXCLUSIVE REMEDY AND LIMITATION OF WARRANTY UNDER NO CIRCUMSTANCES SHALL DSC BE LIABLE FOR ANY SPECIAL, INCIDENTAL, CONSEQUENTIAL OR INDIRECT DAMAGES BASED UPON BREACH OF WARRANTY, BREACH OF CONTRACT, NEGLIGENCE, STRICT LIABILITY, OR ANY OTHER LEGAL THEORY. SUCH DAMAGES INCLUDE, BUT ARE NOT LIMITED TO, LOSS OF PROFITS, LOSS OF THE SOFTWARE PRODUCT OR ANY ASSOCIATED EQUIPMENT, COST OF CAPITAL, COST OF SUBSTITUTE OR REPLACEMENT EQUIPMENT, FACILITIES OR SERVICES, DOWN TIME, PURCHASERS TIME, THE CLAIMS OF THIRD PARTIES, INCLUDING CUSTOMERS, AND INJURY TO PROPERTY.

WARNING: DSC recommends that the entire system be completely tested on a regular basis. However, despite frequent testing, and due to, but not limited to, criminal tampering or electrical disruption, it is possible for this SOFTWARE PRODUCT to fail to perform as expected.

MODIFICATION STATEMENT

Digital Security Controls has not approved any changes or modifications to this device by the user. Any changes or modifications could void the user's authority to operate the equipment.

Digital Security Controls n'approuve aucune modification apportée à l'appareil par l'utilisateur, quelle qu'en soit la nature. Tout changement ou modification peut annuler le droit d'utilisation de l'appareil par l'utilisateur.

INTERFERENCE STATEMENT This device complies with Part 15 of the FCC Rules and Industry Canada licence-exempt RSS standard(s). Operation is subject to the following two conditions: (1) this device may not cause interference, and (2) this device must accept any interference, including interference that may cause undesired operation of the device. Le présent appareil est conforme aux CNR d'Industrie Canada applicables aux appareils radio exempts de licence. L'exploitation est autorisée aux deux conditions suivantes : (1) l'appareil ne doit pas produire de brouillage, et (2) l'utilisateur de l'appareil doit accepter tout brouillage radioélectrique subi, même si le brouillage est susceptible d'en compromettre le fonctionnement.

WIRELESS NOTICE

This equipment complies with FCC and IC radiation exposure limits set forth in an uncontrolled environment. The antenna should be installed and operated with minimum distance of 20 cm between the radiator and your body. Antenna gain must be below:

Frequency Band	3G4010
GSM 850 / FDD V	6.21 dBi
PCS 1900 / FDD II	3.76 dBi

This transmitter must not be co-located or operating in conjunction with any other antenna or transmitter.

Cet appareil est conforme aux limites d'exposition aux rayonnements de la IC pour un environnement non contrôlé. L'antenne doit être installée de façon à garder une distance minimale de 20 centimètres entre la source de rayonnements et votre corps.

Gain de l'antenne doit être ci-dessous:

Bande de fréquence	3G4010
GSM 850 / FDD V	6.21 dBi
PCS 1900 / FDD II	3.76 dBi

L'émetteur ne doit pas être colocalisé ni fonctionner conjointement avec à autre antenne ou autre émetteur.

FCC CLASS B DIGITAL DEVICE NOTICE

This equipment has been tested and found to comply with the limits for a Class B digital device, pursuant to part 15 of the FCC Rules. These limits are designed to provide reasonable protection against harmful interference in a residential installation. This equipment generates uses and can radiate radio frequency energy and, if not installed and used in accordance with the instructions, may cause harmful interference to radio communications. However, there is no guarantee that interference will not occur in a particular installation. If this equipment does cause harmful interference to radio or television reception, which can be determined by turning the equipment off and on, the user is encouraged to try to correct the interference by one or more of the following measures:

- Reorient or relocate the receiving antenna.
- Increase the separation between the equipment and receiver.
- Connect the equipment into an outlet on a circuit different from that to which the receiver is connected.
- Consult the dealer or an experienced radio/TV technician for help CAN ICES-3 (B) / NMB-3 (B)

This Class B digital apparatus complies with Canadian ICES-003.

Cet appareil numérique de classe B est conforme à la norme canadienne ICES-003.

FCC ID:F53143G4010

3G4010 Product Identifier US: F5314M000B3G4010

REN:0.0B

USOC Jack:RJ-31X

Telephone Connection Requirements

A plug and jack used to connect this equipment to the premises wiring and telephone network must comply with the applicable FCC Part 68 rules and requirements adopted by the ACTA. A compliant telephone cord and modular plug is provided with this product. It is designed to be connected to a compatible modular jack that is also compliant. See installation instructions for details.

Ringer Equivalence Number (REN)

The REN is used to determine the number of devices that may be connected to a telephone line. Excessive RENs on a telephone line may result in the devices not ringing in response to an incoming call.

In most but not all areas, the sum of RENs should not exceed five (5.0). To be certain of the number of devices that may be connected to a line, as determined by the total RENs, contact the local Telephone Company. For products

approved after July 23, 2001, the REN for this product is part of the product identifier that has the format: US: AAEEQ##TXXXX. The digits represented by ## are the REN without a decimal point (e.g., 03 is a REN of 0.3). For earlier products, the REN is separately shown on the label.

Incidence of Harm

If this equipment 3G4010 causes harm to the telephone network, the telephone company will notify you in advance that temporary discontinuance of service may be required. But if advance notice is not practical, the Telephone Company will notify the customer as soon as possible. Also, you will be advised of your right to file a complaint with the FCC if you believe it is necessary.

Changes in Telephone Company Equipment or Facilities

The Telephone Company may make changes in its facilities, equipment, operations or procedures that could affect the operation of the equipment. If this happens the Telephone Company will provide advance notice in order for you to make necessary modifications to maintain uninterrupted service.

Equipment Maintenance Facility

If trouble is experienced with this equipment for repair or warranty information, please contact the facility indicated below. If the equipment is causing harm to the telephone network, the Telephone Company may request that you disconnect the equipment until the problem is solved. This equipment is of a type that is not intended to be repaired by the end user.

DSC c/o APL Logistics, 757 Douglas Hill Rd., Lithia Springs, GA 30122

Additional Information

Connection to party line service is subject to state tariffs. Contact the state public utility commission, public service commission or corporation commission for information.

Alarm dialling equipment must be able to seize the telephone line and place a call in an emergency situation. It must be able to do this even if other equipment (telephone, answering system, computer modem, etc.) already has the telephone line in use. To do so, alarm dialling equipment must be connected to a properly installed RJ-31X jack that is electrically in series with and ahead of all other equipment attached to the same telephone line. Proper installation is depicted in the figure below. If you have any questions concerning these instructions, you should consult your telephone company or a qualified installer about installing the RJ-31X jack and alarm dialling equipment for you.

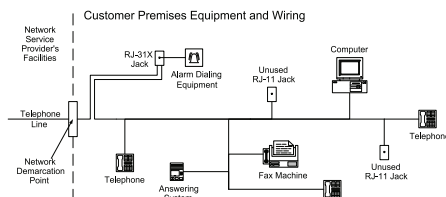

Industry Canada Compliance Statement

This Equipment meets the applicable Industry Canada Terminal Equipment Technical Specifications. This is confirmed by the registration number. The abbreviation, IC, before the registration number signifies that registration was performed based on a Declaration of Conformity indicating that Industry Canada technical specifications were met. It does not imply that that Industry Canada approved the equipment. The Ringer Equivalence Number (REN) for this terminal equipment is 0.0. The REN assigned to each terminal equipment provides an indication of the maximum number of terminals allowed to be connected to a telephone interface. The termination on an interface may consist of any combination of devices subject only to the requirement that the sum of the Ringer Equivalence Numbers of all devices does not exceed 5.

IC: 160A-3G4010

Cet équipement est conforme aux spécifications techniques applicables aux équipements terminaux d'Industrie Canada. Ceci est confirmé par le numéro d'enregistrement. L'abréviation IC précédant le numéro d'enregistrement signifie que l'enregistrement a été effectué sur la base de la Déclaration de conformité indiquant que le produit est conforme aux spécifications techniques d'Industrie Canada. Ceci n'implique pas que le produit ait été approuvé par Industrie Canada. Le nombre équivalent de sonneries (REN) de cet appareil terminal est 0.0. Le REN attribué à chaque équipement terminal fournit une indication sur le nombre maximum de terminaux pouvant être connectés sur une interface téléphonique. La terminaison sur une interface peut constituer en n'importe quelle combinaison d'appareils, à la condition seulement que la somme des Nombres équivalents de sonneries de tous les appareils ne soit pas supérieure à 5.

This Class B digital apparatus meets all requirements of the Canadian interference-causing equipment regulations. Cet appareil numérique de la Classe B respecte toutes les exigences de règlement sur le matériel brouilleur du Canada.

The term "IC" before the radio certification number only signifies that Industry Canada technical specifications were met.

WARNING: To satisfy FCC RF exposure requirements for mobile transmitting devices, a separation distance of 20cm or more must be maintained between the antenna of this device and persons during device operation.

Limited Warranty

Digital Security Controls warrants the original purchaser that for a period of twelve months from the date of purchase, the product shall be free of defects in materials and workmanship under normal use. During the warranty period, Digital Security Controls shall, at its option, repair or replace any defective product upon return of the product to its factory, at no charge for labour and materials. Any replacement and/or repaired parts are warranted for the remainder of the original warranty or ninety (90) days, whichever is longer. The original purchaser must promptly notify Digital Security Controls in writing that there is defect in material or workmanship, such written notice to be received in all events prior to expiration of the warranty period. There is absolutely no warranty on software and all software products are sold as a user license under the terms of the software license agreement included with the product. The Customer assumes all responsibility for the proper selection, installation, operation and maintenance of any products purchased from DSC. Custom products are only warranted to the extent that they do not function upon delivery. In such cases, DSC can replace or credit at its option.

International Warranty

The warranty for international customers is the same as for any customer within Canada and the United States, with the exception that Digital Security Controls shall not be responsible for any customs fees, taxes, or VAT that may be due.

Warranty Procedure

To obtain service under this warranty, please return the item(s) in question to the point of purchase. All authorized distributors and dealers have a warranty program. Anyone returning goods to Digital Security Controls must first obtain an authorization number. Digital Security Controls will not accept any shipment whatsoever for which prior authorization has not been obtained.

Conditions to Void Warranty

This warranty applies only to defects in parts and workmanship relating to normal use. It does not cover:

- damage incurred in shipping or handling;
- damage caused by disaster such as fire, flood, wind, earthquake or lightning;
- damage due to causes beyond the control of Digital Security Controls such as excessive voltage, mechanical shock or water damage;
- damage caused by unauthorized attachment, alterations, modifications or foreign objects;
- damage caused by peripherals (unless such peripherals were supplied by Digital Security Controls);
- defects caused by failure to provide a suitable installation environment for the products;
- damage caused by use of the products for purposes other than those for which it was designed;
- damage from improper maintenance;
- damage arising out of any other abuse, mishandling or improper application of the products.

Items Not Covered by Warranty

In addition to the items which void the Warranty, the following items shall not be covered by Warranty: (i) freight cost to the repair centre; (ii) products which are not identified with DSC's product label and lot number or serial number; (iii) products disassembled or repaired in such a manner as to adversely affect performance or

prevent adequate inspection or testing to verify any warranty claim. Access cards or tags returned for replacement under warranty will be credited or replaced at DSC's option. Products not covered by this warranty, or otherwise out of warranty due to age, misuse, or damage shall be evaluated, and a repair estimate shall be provided. No repair work will be performed until a valid purchase order is received from the Customer and a Return Merchandise Authorisation number (RMA) is issued by DSC's Customer Service.

Digital Security Controls' liability for failure to repair the product under this warranty after a reasonable number of attempts will be limited to a replacement of the product, as the exclusive remedy for breach of warranty. Under no circumstances shall Digital Security Controls be liable for any special, incidental, or consequential damages based upon breach of warranty, breach of contract, negligence, strict liability, or any other legal theory. Such damages include, but are not limited to, loss of profits, loss of the product or any associated equipment, cost of capital, cost of substitute or replacement equipment, facilities or services, down time, purchaser's time, the claims of third parties, including customers, and injury to property. The laws of some jurisdictions limit or do not allow the disclaimer of consequential damages. If the laws of such a jurisdiction apply to any claim by or against DSC, the limitations and disclaimers contained here shall be to the greatest extent permitted by law. Some states do not allow the exclusion or limitation of incidental or consequential damages, so that the above may not apply to you.

Disclaimer of Warranties

This warranty contains the entire warranty and shall be in lieu of any and all other warranties, whether expressed or implied (including all implied warranties of merchantability or fitness for a particular purpose) and of all other obligations or liabilities on the part of Digital Security Controls. Digital Security Controls neither assumes responsibility for nor authorizes any other person purporting to act on its behalf to modify or to change this warranty, nor to assume for it any other warranty or liability concerning this product.

This disclaimer of warranties and limited warranty are governed by the laws of the province of Ontario, Canada.

WARNING: Digital Security Controls recommends that the entire system be completely tested on a regular basis. However, despite frequent testing, and due to, but not limited to, criminal tampering or electrical disruption, it is possible for this product to fail to perform as expected.

Out of Warranty Repairs

Digital Security Controls will at its option repair or replace out-of-warranty products which are returned to its factory according to the following conditions. Anyone returning goods to Digital Security Controls must first obtain an authorization number. Digital Security Controls will not accept any shipment whatsoever for which prior authorization has not been obtained.

Products which Digital Security Controls determines to be repairable will be repaired and returned. A set fee which Digital Security Controls has predetermined and which may be revised from time to time, will be charged for each unit repaired.

© 2014 Tyco International Ltd. and its Respective Companies. All Rights Reserved.

The trademarks, logos, and service marks displayed on this document are registered in the United States [or other countries]. Any misuse of the trademarks is strictly prohibited and Tyco International Ltd. will aggressively enforce its intellectual property rights to the fullest extent of the law, including pursuit of criminal prosecution wherever necessary. All trademarks not owned by Tyco International Ltd. are the property of their respective owners, and are used with permission or allowed under applicable laws.

Product offerings and specifications are subject to change without notice. Actual products may vary from photos. Not all products include all features. Availability varies by region; contact your sales representative.

DSC

Tech Support: 1-800-387-3630 (Canada & US) or 905-760-30000 - www.dsc.com



29009085R001

From Tyco Security Products