



www.nemko.com

Nemko Canada Inc., 303 River Road, R.R. 5, Ottawa, Ontario, Canada, K1V 1H2

Report number: 161041-1TRFWL

Apparatus: Wireless Alarm Repeater

Applicant: Digital Security Controls, a Division of Tyco Safety
Products Canada Ltd.
3301 Langstaff Road
Concord, ON, Canada
L4K 4L2

FCC ID: F5310WS4920

Test specification:

Title 47-Telecommunication

Chapter I - Federal Communications Commission

Subchapter A - General

Part 15 - Radio Frequency Devices

Subpart C - Intentional Radiators

§15.231- Periodic operation in the band 40.66–40.70 MHz and above 70 MHz

Reviewed by: 

Signature
Richard Brazeau, Laboratory Manager

Date: November 22, 2010

Tested by: Kevin Ma, Technical Assessor

Nemko Canada Inc. authorizes the applicant to reproduce this report provided it is reproduced in its entirety and for use by the company's employees only. Any use which a third party makes of this report, or any reliance on or decisions to be made based on it, are the responsibility of such third parties.

Nemko Canada Inc. accepts no responsibility for damages, if any suffered by any third party as a result of decisions made or actions based on this report.

This report shall not be reproduced except in full without the written approval of the testing laboratory.



Nemko Canada Inc., a testing laboratory, is accredited by the Standards Council of Canada.
The tests included in this report are within the scope of this accreditation.



Table of contents

Section 1: Report summary	3
Section 2: Equipment under test	4
2.1 Identification of equipment under test (EUT)	4
2.2 Accessories and support equipment	4
2.3 EUT description	4
2.4 Technical specifications of the EUT	4
2.5 EUT setup diagram	5
2.6 Operation of the EUT during testing	5
2.7 Modifications incorporated in the EUT	5
Section 3: Test conditions	6
3.1 Deviations from laboratory tests procedures	6
3.2 Test conditions, power source and ambient temperatures	6
3.3 Measurement uncertainty	7
3.4 Test equipment	7
Section 4: Result summary	8
4.1 FCC Part 15 Subpart C, 15.231: Test results	8
Appendix A: Test results	9
Clause 15.31(e) Variation of the power source	9
Clause 15.203 Antenna requirement	10
Clause 15.207(a) Conducted limits	11
Clause 15.231(a) Conditions for intentional radiators to comply with periodic operation	14
Clause 15.231(b) Field strength of emissions	17
Clause 15.231(c) Emission bandwidth	22
Appendix B: Block diagrams of test set-ups	23



Nemko Canada Inc.,
303 River Road, R.R. 5, Ottawa, Ontario, Canada, K1V 1H2

Section 1: Report summary

Report Number: 161041-1TRFWL

Specification: FCC 15.231

Section 1: Report summary

This report contains an assessment of apparatus against specifications based upon tests carried out on samples submitted at Nemko Canada Inc.

Test specification:

FCC Part 15 Subpart C, 15.231

Periodic operation in the band 40.66–40.70 MHz and above 70 MHz.

Compliance status:	Complies
Exclusions:	None
Non-compliances:	None
Report release history:	Original release
Test location:	Nemko Canada Inc. 303 River Road, R.R. 5, Ottawa, Ontario, Canada, K1V 1H2
Registration number:	176392 (3 m Semi anechoic chamber)

Note that the results contained in this report relate only to the items tested and were obtained in the period between the date of initial receipt of samples and the date of issue of the report.

This test report has been completed in accordance with the requirements of ISO/IEC 17025. All results contain in this report are within Nemko Canada's ISO/IEC 17025 accreditation.

Nemko Canada Inc. authorizes the applicant to reproduce this report provided it is reproduced in its entirety and for use by the company's employees only.

Any use which a third party makes of this report, or any reliance on or decisions to be made based on it, are the responsibility of such third parties. Nemko Canada Inc. accepts no responsibility for damages, if any, suffered by any third party as a result of decisions made or actions based on this report.

Section 2: Equipment under test

2.1 Identification of equipment under test (EUT)

The following information identifies the EUT under test:

Type of equipment:	Wireless Alarm Repeater
Brand name:	DSC
Model number:	WS4920
Serial number:	None
Nemko sample number:	1
FCC ID:	F5310WS4920
Date of receipt:	November 15, 2010

2.2 Accessories and support equipment

The following information identifies accessories used to exercise the EUT during testing:

Type of equipment:	AC Transformer
Brand name:	DSC
Model number:	PTD1620
Serial number:	88014319
Nemko sample number:	3
Date of receipt:	November 15, 2010

2.3 EUT description

The WS4920 is a Wireless Alarm Repeater to be used with 433.92 MHz DSC security systems.

2.4 Technical specifications of the EUT

Operating frequency:	433.92 MHz
Modulation type:	OOK
Occupied bandwidth:	11.2 kHz
Emission designator:	P1D
Antenna data and type:	Integral, 0 dBi Permanent fixed antenna, which may be built-in, (Equipment does not have an external 50 Ω RF connector)
Power source:	120 VAC, 60 Hz
Hardware Version	UA584 Rev. 01
Software Version:	SW Rev. 1.00

Section 2: Equipment under test, continued

2.5 EUT setup diagram

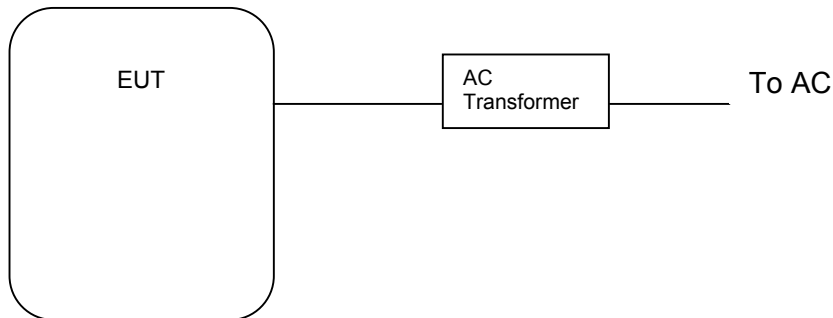

2.6 Operation of the EUT during testing

A modified sample was provided for continues transmission to complete radiated measurements and a normal sample for occupied bandwidth and timing requirements.

2.7 Modifications incorporated in the EUT

There were no modifications performed to the EUT during this assessment.

Section 3: Test conditions

3.1 Deviations from laboratory tests procedures

No deviations were made from laboratory test procedures.

3.2 Test conditions, power source and ambient temperatures

Normal temperature, humidity and air pressure test conditions	Temperature: 15–30 °C Relative humidity: 20–75 % Air pressure: 86–106 kPa When it is impracticable to carry out tests under these conditions, a note to this effect stating the ambient temperature and relative humidity during the tests shall be recorded and stated.
Power supply range:	The normal test voltage for equipment to be connected to the mains shall be the nominal mains voltage. For the purpose of the present document, the nominal voltage shall be the declared voltage, or any of the declared voltages $\pm 5\%$, for which the equipment was designed.



Nemko Canada Inc.,
303 River Road, R.R. 5, Ottawa, Ontario, Canada, K1V 1H2

Section 3: Test conditions

Report Number: 161041-1TRFWL

Specification: FCC 15.231

Section 3: Test conditions, continued

3.3 Measurement uncertainty

Nemko Canada measurement uncertainty has been calculated using guidance of UKAS LAB 34:2003 and TIA-603-B Nov 7, 2002. All calculations have been performed to provide a confidence level of 95 % and can be found in Nemko Canada document MU-003.

3.4 Test equipment

Equipment	Manufacturer	Model No.	Asset/Serial No.	Next cal.
Bilog	Sunol	JB3	FA002108	Jan. 27/11
Receiver/Spectrum Analyzer	Rohde & Schwarz	ESU 26	FA002043	Dec. 16/10
Horn Antenna #2	EMCO	3115	FA000825	Jan. 21/11
50 Coax cable	HUBER + SUHNER	None	FA002013	Sep. 02/11
50 Coax cable	HUBER + SUHNER	None	FA002074	July 07/11
1 – 18 GHz Amplifier	JCA	JCA118-503	FA002091	Oct. 2/11
Spectrum Analyzer	Rohde & Schwarz	FSP 40	FA001920	May 17/11
LISN	Tegam	95300-50	FA000986	Jan. 22/11
LISN	Tegam	95300-50	FA000987	Jan. 22/11
International Power Supply	California Inst.	3001i	FA001021	COU

Note: N/A = Not Applicable, NCR = No Cal Required, COU = CAL On Use

Section 4: Result summary

4.1 FCC Part 15 Subpart C, 15.231: Test results

The column headed 'Required' indicates whether the associated clauses were invoked for the apparatus under test. The following abbreviations are used:

N	No : not applicable / not relevant.
Y	Yes : Mandatory i.e. the apparatus shall conform to these tests.
N/T	Not Tested, mandatory but not assessed. (See report summary)

Part	Test description	Required	Result
General requirements for FCC Part 15			
§15.31(e)	Variation of power source	Y	Pass
§15.203	Antenna requirement	Y	Pass
§15.207(a)	Conducted limits	Y	Pass
Specific requirements for FCC Part 15 Subpart C, 15.231			
§15.231(a)	Conditions for intentional radiators to comply with periodic operation	---	---
§15.231(a)(1)	Manually operated transmitter	Y	Pass
§15.231(a)(2)	Automatically activated transmitter	Y	Pass
§15.231(a)(3)	Periodic transmissions at regular predetermined intervals	Y	Pass
§15.231(a)(4)	Radiators used in cases of emergency	N	---
§15.231(a)(5)	Set-up information transmission for security systems	N	---
§15.231(b)	Field strength of emissions	Y	Pass
§15.231(c)	Emission bandwidth	Y	Pass
§15.231(d)	Requirements for devices operating within 40.66–40.70 MHz band	N	---
§15.231(e)	Field strength of emissions for periodic radiators	N	---
Notes: None			



Nemko Canada Inc.,
303 River Road, R.R. 5, Ottawa, Ontario, Canada, K1V 1H2

Appendix A: Test results

Report Number: 161041-1TRFWL

Specification: FCC 15.231

Appendix A: Test results

Clause 15.31(e) Variation of the power source

For intentional radiators, measurements of the variation of the input power or the radiated signal level of the fundamental frequency component of the emission, as appropriate, shall be performed with the supply voltage varied between 85 % and 115 % of the nominal rated supply voltage. For battery-operated equipment, the equipment tests shall be performed using a new battery.

Test date: November 17, 2010

Test results: Pass

Test data

- Fundamental field strength was measured while supply voltage was varied from 102 VAC to 138 VAC via AC transformer (85 % to 115 % of the nominal rated supply voltage).
- No change in fundamental field strength was observed.



Nemko Canada Inc.,
303 River Road, R.R. 5, Ottawa, Ontario, Canada, K1V 1H2

Appendix A: Test results

Report Number: 161041-1TRFWL

Specification: FCC 15.231

Clause 15.203 Antenna requirement

An intentional radiator shall be designed to ensure that no antenna other than that furnished by the responsible party shall be used with the device. The use of a permanently attached antenna or of an antenna that uses a unique coupling to the intentional radiator shall be considered sufficient to comply with the provisions of this section. The manufacturer may design the unit so that a broken antenna can be replaced by the user, but the use of a standard antenna jack or electrical connector is prohibited. Further, this requirement does not apply to intentional radiators that must be professionally installed, such as perimeter protection systems and some field disturbance sensors, or to other intentional radiators which, in accordance with §15.31(d), must be measured at the installation site. However, the installer shall be responsible for ensuring that the proper antenna is employed so that the limits in this part are not exceeded.

Test date: November 17, 2010

Test results: Pass

Test data

The EUT uses an integral antenna.



Nemko Canada Inc.,
303 River Road, R.R. 5, Ottawa, Ontario, Canada, K1V 1H2

Clause 15.207(a) Conducted limits

An intentional radiator that is designed to be connected to the public utility (AC) power line, the radio frequency voltage that is conducted back onto the AC power line on any frequency or frequencies, within the band 150 kHz to 30 MHz, shall not exceed the limits in the following table, as measured using a 50 μ H/50 Ω line impedance stabilization network (LISN). Compliance with the provisions of this paragraph shall be based on the measurement of the radio frequency voltage between each power line and ground at the power terminal. The lower limit applies at the boundary between the frequency ranges.

Frequency of emission (MHz)	Conducted limit (dB μ V)	
	Quasi-peak	Average
0.15–0.5	66 to 56*	56 to 46*
0.5–5	56	46
5–30	60	50

*-Decreases with the logarithm of the frequency.

Test date: November 17, 2010

Test results: Pass

Special notes

Port under test: AC Mains port of external power supply.

Preview measurements:

0.15 MHz to 30 MHz

Receiver settings:

- Peak and average detector
- 9 kHz RBW

Final measurement:

0.15 MHz to 30 MHz

Receiver settings:

- Q-Peak and average detector
- 9 kHz RBW

- Spectral plots have been corrected for transducer factors; cable loss, LISN, and attenuators.
- Emissions detected within 6 dB of limit were re-measured with a quasi peak or average detector for a final measurement.

Clause 15.207(a) Conducted limits, continued

Test data

Phase:

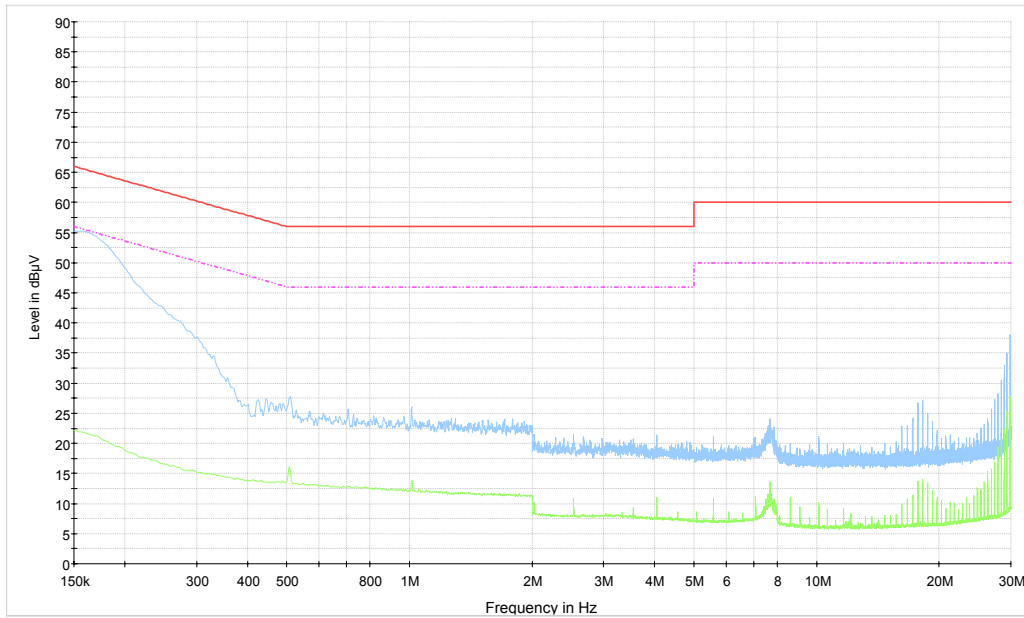

— CISPR 22 Mains QP Class B.LimitLine — CISPR 22 Mains AV Class B.LimitLine — Preview Result 1 — Preview Result 2

Neutral:

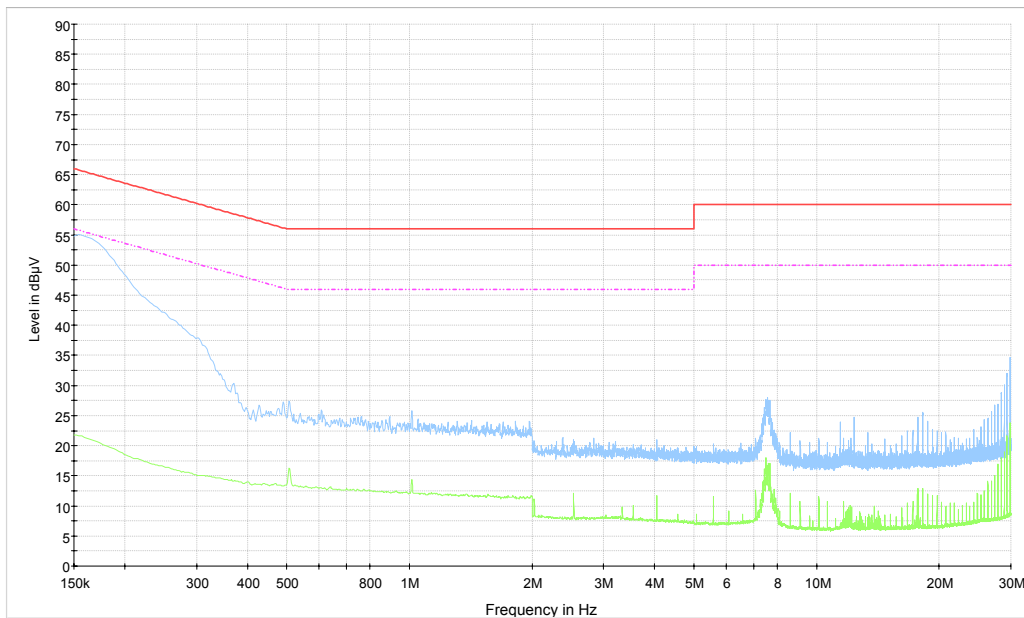

— CISPR 22 Mains QP Class B.LimitLine — CISPR 22 Mains AV Class B.LimitLine — Preview Result 1 — Preview Result 2

Clause 15.207(a) Conducted limits, continued

Set up photo



Clause 15.231(a) Conditions for intentional radiators to comply with periodic operation

The provisions of this section are restricted to periodic operation within the band 40.66–40.70 MHz and above 70 MHz. Except as shown in paragraph (e) of this section, the intentional radiator is restricted to the transmission of a control signal such as those used with alarm systems, door openers, remote switches, etc. Continuous transmissions, voice, video and the radio control of toys are not permitted. Data is permitted to be sent with a control signal. The following conditions shall be met to comply with the provisions for this periodic operation:

- (1) A manually operated transmitter shall employ a switch that will automatically deactivate the transmitter within not more than 5 seconds of being released.
- (2) A transmitter activated automatically shall cease transmission within 5 seconds after activation.
- (3) Periodic transmissions at regular predetermined intervals are not permitted. However, polling or supervision transmissions, including data, to determine system integrity of transmitters used in security or safety applications are allowed if the total duration of transmissions does not exceed more than two seconds per hour for each transmitter. There is no limit on the number of individual transmissions, provided the total transmission time does not exceed two seconds per hour.

Test date: Test date: November 17, 2010

Test results: Pass

Special notes

The EUT is manually triggered and automatically activated transmitter, and has a supervision transmission to determine system integrity.

Clause 15.231(a) Conditions for intentional radiators to comply with periodic operation

Test data

Plot of the timing performance

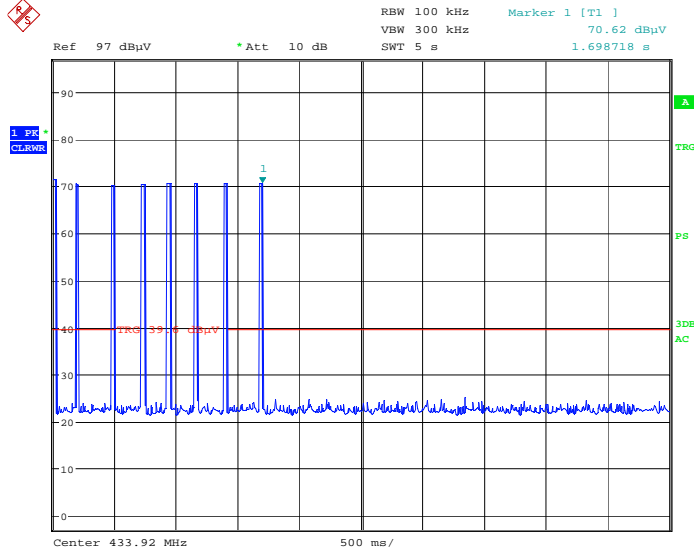

Date: 17.NOV.2010 20:32:45

For Manually triggered event, and automatically activated event, EUT has the same timing performances, it will automatically deactivate the transmission within not more than 5 seconds after being released or activation.



Nemko Canada Inc.,
303 River Road, R.R. 5, Ottawa, Ontario, Canada, K1V 1H2

Clause 15.231(a) Conditions for intentional radiators to comply with periodic operation

Test data

Plot of supervision transmission

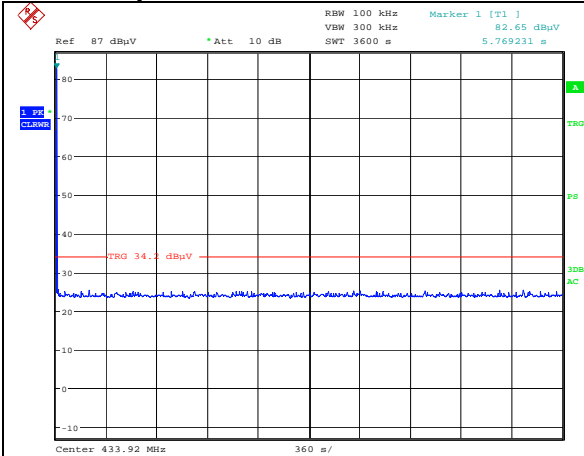

Date: 16.NOV.2010 22:26:31

1 transmissions event (two packets) per 1 hr.

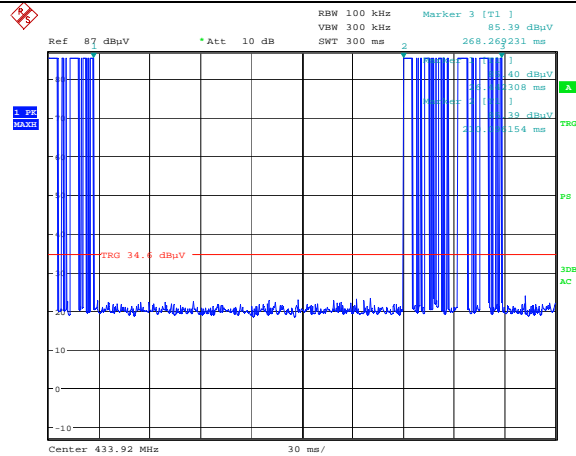

Date: 16.NOV.2010 20:04:01

1 transmission event (two packets) duration

Total duration of supervision transmissions is 270 ms, less than the limits of two seconds per hour.

Clause 15.231(b) Field strength of emissions

In addition to the provisions of §15.205, the field strength of emissions from intentional radiators operated under this section shall not exceed the following:

Fundamental frequency (MHz)	Field strength of fundamental		Field strength of spurious emissions	
	($\mu\text{V}/\text{m}$)	($\text{dB}\mu\text{V}/\text{m}$)	($\mu\text{V}/\text{m}$)	($\text{dB}\mu\text{V}/\text{m}$)
40.66–40.70	2,250	67	225	47
70–130	1,250	61.9	125	41.9
130–174	1,250 to 3,750*	61.9 to 71.5*	125 to 375*	41.9 to 51.5*
174–260	3,750	71.5	375	51.5
260–470	3,750 to 12,500*	71.5 to 81.9*	375 to 1,250*	51.5 to 61.9*
Above 470	12,500	81.9	1,250	61.9

*-Linear interpolations.

The above field strength limits are specified at a distance of 3 meters. The tighter limits apply at the band edges.

The field strength of emissions appearing within restricted bands (as specified in §15.205) shall not exceed the limits from §15.209:

Frequency (MHz)	Field strength		Measurement distance (m)
	($\mu\text{V}/\text{m}$)	($\text{dB}\mu\text{V}/\text{m}$)	
0.009–0.490	2400/F	67.6–20log(F)	300
0.490–1.705	24000/F	87.6–20log(F)	30
1.705–30.0	30	29.5	30
30–88	100	40.0	3
88–216	150	43.5	3
216–960	200	46.0	3
above 960	500	54.0	3

Notes:

- F = fundamental frequency in kHz
- In the emission table above, the tighter limit applies at the band edges.
- For frequencies above 1 GHz the limit on peak RF emissions is 20 dB above the maximum permitted average emission limit applicable to the equipment under test.

Test date: November 17, 2010

Test results: Pass

Clause 15.231(b) Field strength of emissions, continued

Special notes

- The spectrum was searched from 30 MHz to the 10th harmonic.
- All measurements were performed at a distance of 3 m.
- All measurements were performed:
 - within 30–1000 MHz range: using a peak detector with 100 kHz/300 kHz RBW/VBW,
 - above 1 GHz: using peak detector with 1 MHz/3 MHz RBW/VBW for peak results
 - using a duty cycle/average factor for average results calculations.
- The EUT was measured positioned vertically and horizontally to obtain maximum emissions.
- Only the worst data presented in the test report.

§ 15.205 Restricted bands of operation.

MHz	MHz	MHz	GHz
0.090–0.110	16.42–16.423	399.9–410	4.5–5.15
0.495–0.505	16.69475–16.69525	608–614	5.35–5.46
2.1735–2.1905	16.80425–16.80475	960–1240	7.25–7.75
4.125–4.128	25.5–25.67	1300–1427	8.025–8.5
4.17725–4.17775	37.5–38.25	1435–1626.5	9.0–9.2
4.20725–4.20775	73–74.6	1645.5–1646.5	9.3–9.5
6.215–6.218	74.8–75.2	1660–1710	10.6–12.7
6.26775–6.26825	108–121.94	1718.8–1722.2	13.25–13.4
6.31175–6.31225	123–138	2200–2300	14.47–14.5
8.291–8.294	149.9–150.05	2310–2390	15.35–16.2
8.362–8.366	156.52475–156.52525	2483.5–2500	17.7–21.4
8.37625–8.38675	156.7–156.9	2690–2900	22.01–23.12
8.41425–8.41475	162.0125–167.17	3260–3267	23.6–24.0
12.29–12.293	167.72–173.2	3332–3339	31.2–31.8
12.51975–12.52025	240–285	3345.8–3358	36.43–36.5
12.57675–12.57725	322–335.4	3600–4400	Above 38.6
13.36–13.41			



Nemko Canada Inc.,
303 River Road, R.R. 5, Ottawa, Ontario, Canada, K1V 1H2

Clause 15.231(b) Field strength of emissions, continued

Test Data

§15.35(c) When the radiated emission limits are expressed in terms of the average value of the emission, and pulsed operation is employed, the measurement field strength shall be determined by averaging over one complete pulse train, including blanking intervals, as long as the pulse train does not exceed 0.1 seconds.

Duty cycle/average factor calculations:

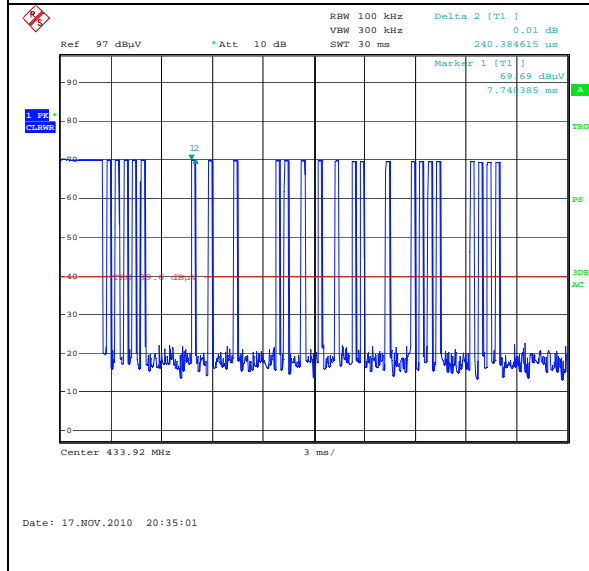
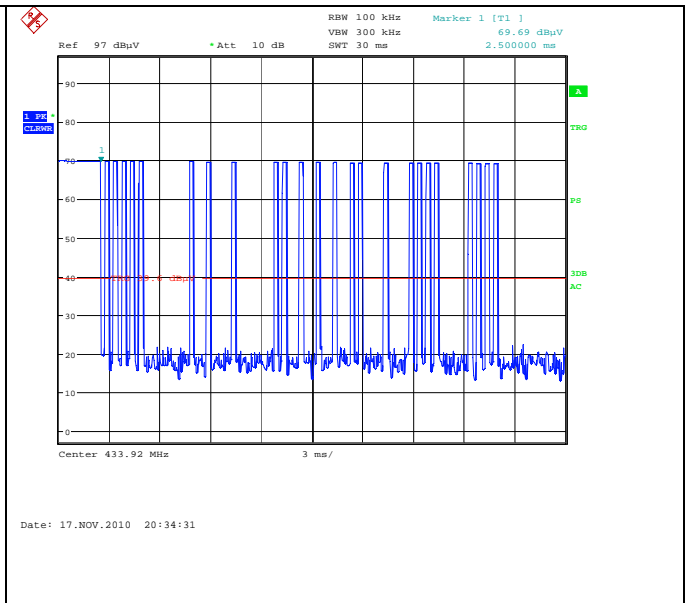
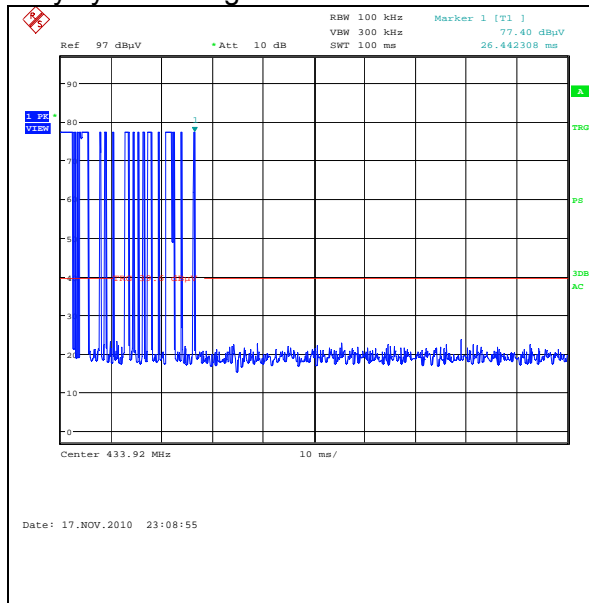

$$Duty\ cycle/average\ factor = 20 \times \log_{10} \left(\frac{T_{x_{100ms}}}{100ms} \right)$$

Tx = 2.5 + 0.241 x 24 = 8.284 ms within 100 ms
 Average factor: 20 x log (0.08284) = -21.63 dB



Nemko Canada Inc.,
303 River Road, R.R. 5, Ottawa, Ontario, Canada, K1V 1H2

Appendix A: Test results

Report Number: 161041-1TRFWL

Specification: FCC 15.231

Clause 15.231(b) Field strength of emissions, continued

Tabular data (15.231(b) emissions limit)

Freq. (MHz)	Pol. V/H	Peak field strength (dB μ V/m)	Peak limit (dB μ V/m)	Peak margin (dB)	Duty cycle corr. (dB)	Avg field strength (dB μ V/m)	Avg limit (dB μ V/m)	Avg margin (dB)
Fundamental								
433.92	H	99.17	100.83	1.66	-21.63	77.54	80.83	3.29
433.92	V	96.32	100.83	4.51	-21.63	74.69	80.83	6.14
Harmonics								
867.84	H	54.30	80.83	26.53	-21.63	32.67	60.83	28.16
867.84	V	51.56	80.83	29.27	-21.63	29.93	60.83	30.90
1301.76	H	58.72	80.83	22.11	-21.63	37.09	60.83	23.74
1301.68	V	53.91	80.83	26.92	-21.63	32.28	60.83	28.55
1735.67	H	56.02	80.83	24.81	-21.63	34.39	60.83	26.44
1735.73	V	51.51	80.83	29.32	-21.63	29.88	60.83	30.95
2169.68	H	65.40	80.83	15.43	-21.63	43.77	60.83	17.06
2169.68	V	61.65	80.83	19.18	-21.63	40.02	60.83	20.81
2603.56	H	68.08	80.83	12.75	-21.63	46.45	60.83	14.38
2603.56	V	64.65	80.83	16.18	-21.63	43.02	60.83	17.81

Notes: using peak detector with 1 MHz/3 MHz RBW/VBW for below 1 GHz peak result, and 1 MHz/3 MHz RBW/VBW for above 1 GHz peak results.

Clause 15.231(b) Field strength of emissions, continued

Setup photos

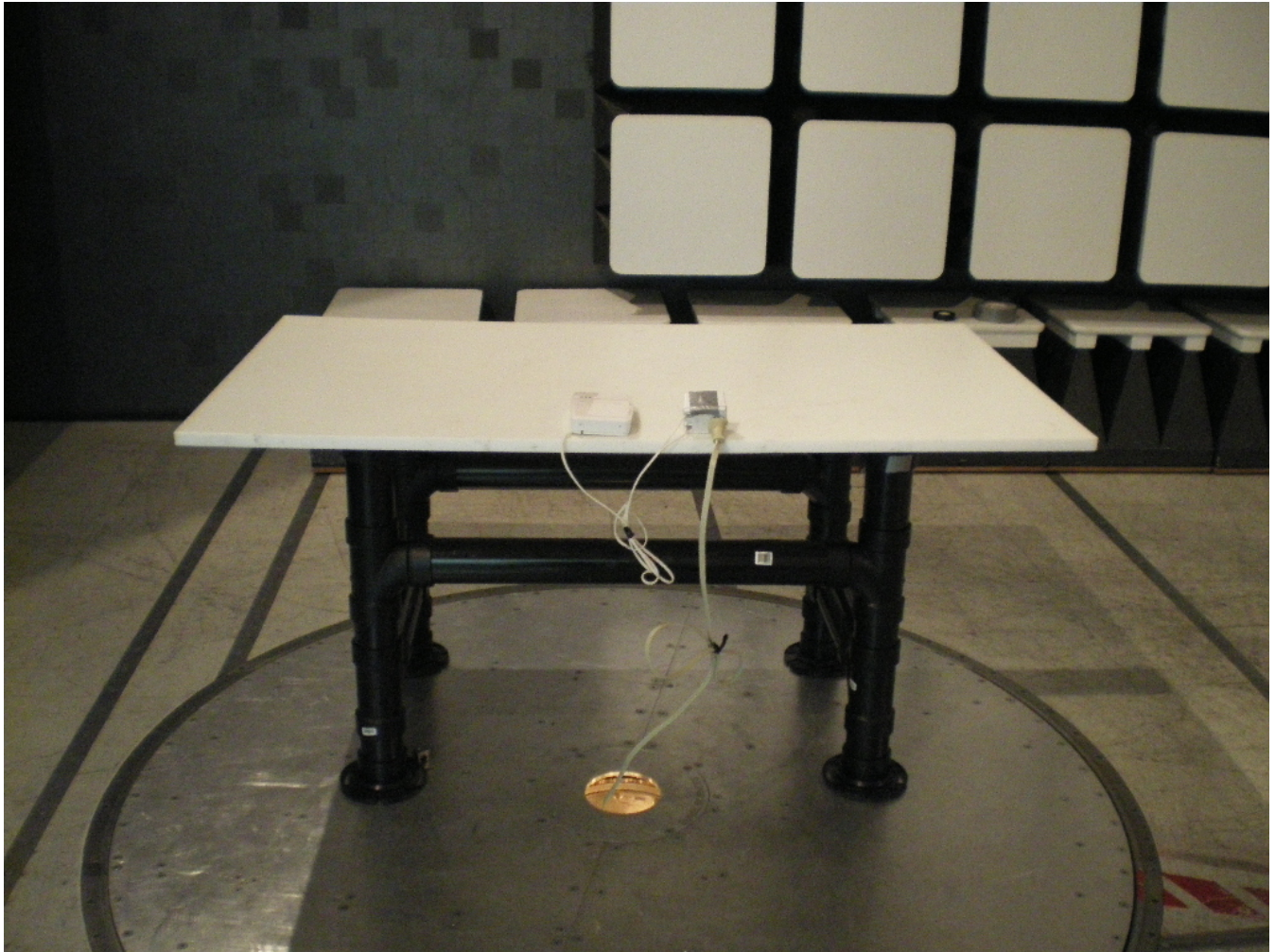



Nemko Canada Inc.,
303 River Road, R.R. 5, Ottawa, Ontario, Canada, K1V 1H2

Clause 15.231(c) Emission bandwidth

The bandwidth of the emission shall be no wider than 0.25 % of the center frequency for devices operating above 70 MHz and below 900 MHz. For devices operating above 900 MHz, the emission shall be no wider than 0.5 % of the center frequency. Bandwidth is determined at the points 20 dB down from the modulated carrier.

Test date: November 17, 2010

Test results: Pass

Special notes

- The test was performed using peak detector of the spectrum analyzer with RBW no narrower than 1 % of the emission bandwidth.

Test data

Calculated limit: $0.25\% \times 433.92 \text{ MHz} = 1084.8 \text{ kHz}$

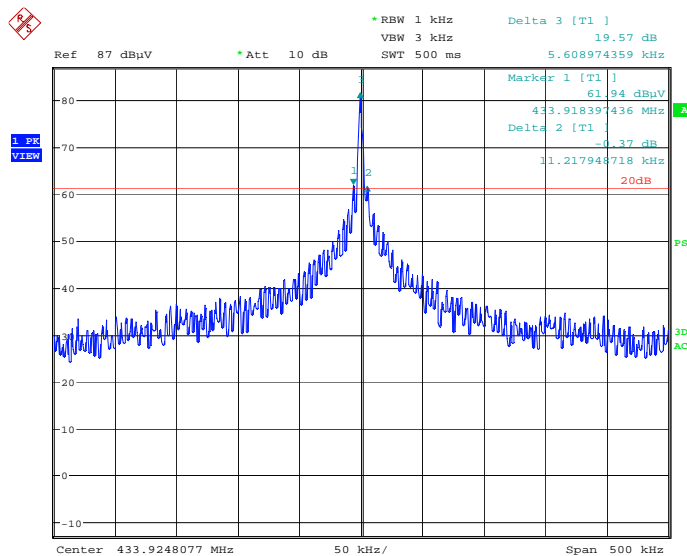

Date: 16.NOV.2010 17:29:25

20 dB bandwidth, kHz	Limit, kHz	Margin, kHz
11.2	1084.8	1073.6

Appendix B: Block diagrams of test set-ups

Radiated emissions set-up

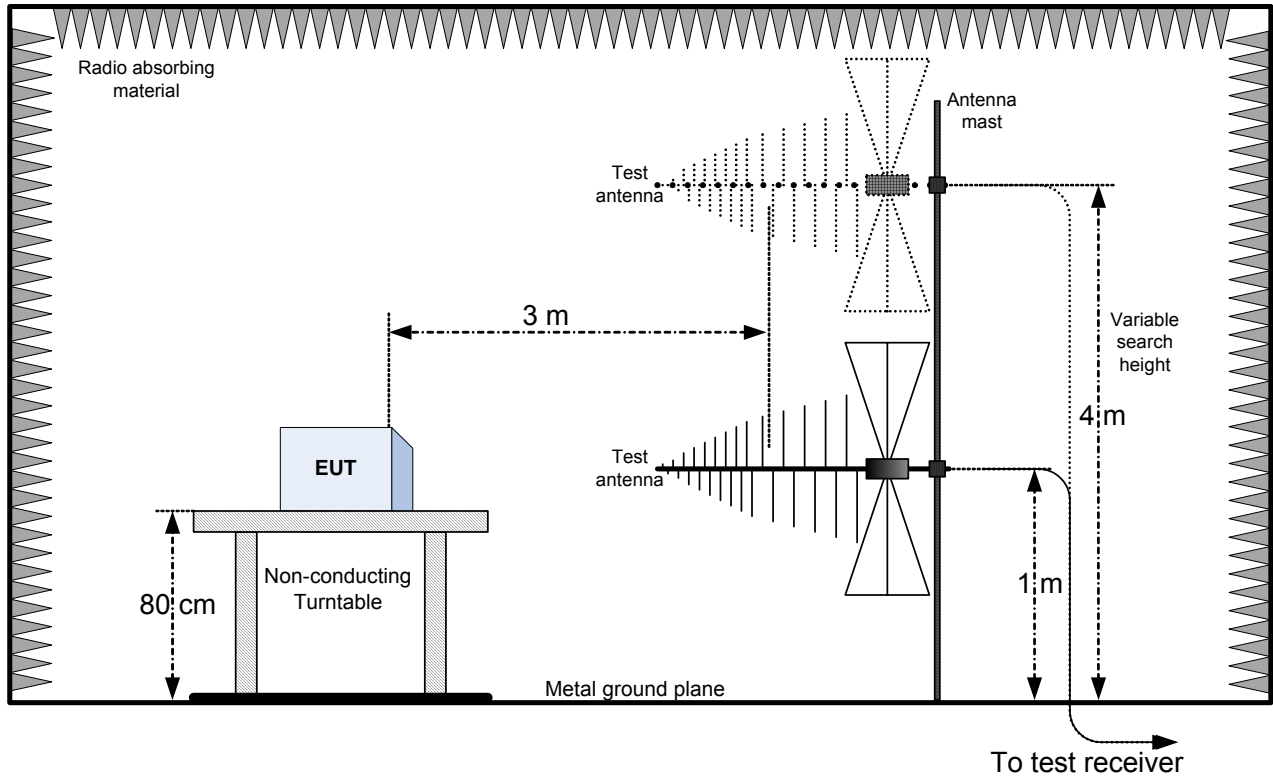

Conducted emissions set-up

