



FCC Test Report

FCC Part 15B

FOR:

MODEL #: TL265GS/TL260GS/GS2065/GS2060

FCC ID: F5309GS260L

TEST REPORT #: EMC_TYCOS_014_08001_15B
DATE: 2009-01-27



Certificate # 2135.01



Bluetooth Qualification
Test Facility
(BQTF)



LAB CODE 20020328-00

FCC listed
A2LA
accredited

IC recognized #
3462B

CETECOM Inc.

411 Dixon Landing Road • Milpitas, CA 95035 • U.S.A.

Phone: + 1 (408) 586 6200 • Fax: + 1 (408) 586 6299 • E-mail: info@cetecomusa.com • <http://www.cetecom.com>

CETECOM Inc. is a Delaware Corporation with Corporation number: 2113686
Board of Directors: Dr. Harald Ansoerge, Dr. Klaus Matkey, Hans Peter May



TABLE OF CONTENTS

1 Assessment _____ 3

2 Administrative Data _____ 4

 2.1 Identification of the Testing Laboratory Issuing the EMC Test Report _____ 4

 2.2 Identification of the Client _____ 4

3 Equipment under Test (EUT) _____ 5

 3.1 Specification of the Equipment under Test _____ 5

 3.2 Identification of the Equipment Under Test (EUT) _____ 5

 3.3 Identification of Accessory equipment _____ 5

4 Subject of Investigation _____ 6

5 Radiated Emissions _____ 7

 5.1 Limits: _____ 7

 5.2 Measurement Procedure: _____ 8

 5.3 Results _____ 10

6 AC POWER LINE CONDUCTED EMISSIONS _____ 16

 6.1 LIMIT SUB CLAUSE § 15.207 _____ 16

 6.2 RESULTS: _____ 17

7 TEST EQUIPMENT AND ANCILLARIES USED FOR TESTS _____ 25

8 BLOCK DIAGRAMS _____ 26

9 Report History _____ 28



1 Assessment

The following is in compliance with the applicable criteria specified in FCC rules Part 15B of the Code of Federal Regulations.

Company	Description	Model #
Digital Security Controls, a Division of Tyco Safety Products Canada Ltd.	GSM/Ethernet Alarm Communicator	TL265GS/TL260GS/GS2065/GS2060

This report reviewed by:

2009-01-27 EMC & Radio **Marc Douat**
 (Project Engineer)

Date Section Name Signature

Project Leader:

2009-01-27 EMC & Radio **Ahmad Safdari**
 (Project Engineer)

Date Section Name Signature

The test results of this test report relate exclusively to the test item specified in Identification of the Equipment under Test. The CETECOM Inc. USA does not assume responsibility for any conclusions and generalizations drawn from the test results with regard to other specimens or samples of the type of the equipment represented by the test item. The test report may only be reproduced or published in full. Reproduction or publication of extracts from the report requires the prior written approval of the CETECOM Inc USA.



2 Administrative Data

2.1 Identification of the Testing Laboratory Issuing the EMC Test Report

Company Name:	CETECOM Inc.
Department:	EMC
Address:	411 Dixon Landing Road Milpitas, CA 95035 U.S.A.
Telephone:	+1 (408) 586 6200
Fax:	+1 (408) 586 6299
Responsible Test Lab Manager:	Lothar Schmidt
Responsible Project Leader:	Ahmad Safdari

2.2 Identification of the Client

APPLICANT	
Applicant (Company Name)	Digital Security Controls, a Division of Tyco Safety Products Canada Ltd.
Street Address	3301 Langstaff Road
City/Zip Code	Concord L4K 4L2
Country	Canada
Contact Person	Dan Nita
Telephone	905-760-3000, Ext. 2706
Fax	905-760-3020
e-mail	dnita@dsc.com



3 Equipment under Test (EUT)

3.1 Specification of the Equipment under Test

Marketing Name:	TL265GS/TL260GS/GS2065/GS2060
Description:	GSM/Ethernet Alarm Communicator
Model No:	TL265GS/TL260GS/GS2065/GS2060
FCC ID:	F5309GS260L

3.2 Identification of the Equipment Under Test (EUT)

EUT #	TYPE	MODEL	SERIAL #	HW Version
1	EUT	TL265GS	N/A	UA557 Rev. 02
2	EUT	TL260GS	N/A	UA557 Rev. 02
3	EUT	GS2065	N/A	UA557 Rev. 02
4	EUT	GS2060	N/A	UA557 Rev. 02

SW version: Ver. 1.0

3.3 Identification of Accessory equipment

AE #	TYPE	MODEL
1	AC Adapter	PTD1640U-CC
2	Battery	CA1270
3	DSC Control Panel	N/A



4 Subject of Investigation

Testing was performed on both TL265GS, TL260GS according to FCC 15 subpart b.

Model GS2060 and GS2065 is a Cellular communicator module using only a GSM/GPRS communication channel. The product is identical in construction and functionality with the model TL260GS and TL265GS with the exception of the IP Ethernet communicator section which is not populated.

Radiated Emission tests are carried out to show that the EUT complies with FCC15.209 (a) radiated emissions limit for Class B device.

Conducted Emission tests are carried out to show that the EUT complies with FCC15.207 Class B.



5 Radiated Emissions

5.1 Limits:

§ 15.109 Radiated emission limits. (a) Except for Class A digital devices, the field strength of radiated emissions from unintentional radiators at a distance of 3 meters shall not exceed the following values:

Frequency of emission (MHz)	Field strength (microvolts/ meter)
30–88	100
88–216	150
216–960	200
Above 960	500

§ 15.109 Radiated emission limits. (b) The field strength of radiated emissions from a Class A digital device, as determined at a distance of 10 meters, shall not exceed the following:

Frequency of emission (MHz)	Field strength (microvolts/ meter)
30–88	90
88–216	150
216–960	210
Above 960	300



5.2 Measurement Procedure:

ANSI C63.4 Section 8.3.1.1: Exploratory radiated emission measurements

Exploratory radiated measurements shall be performed at the measurement distance or at a closer distance than that specified for compliance to determine the emission characteristics of the EUT. At near distances, for EUTs of comparably small size, it is relatively easy to determine the spectrum signature of the EUT and, if applicable, the EUT configuration that produces the maximum level of emissions. A shielded room may be used for exploratory testing, but may have anomalies that can lead to significant errors in amplitude measurements.

Broadband antennas and a spectrum analyzer or a radio-noise meter with a panoramic display are often useful in this type of testing. It is recommended that either a headset or loudspeaker be connected as an aid in detecting ambient signals and finding frequencies of significant emission from the EUT when the exploratory and final testing is performed in an OATS with strong ambient signals. Caution should be taken if either antenna height between 1 and 4 meters or EUT azimuth is not fully explored. Not fully exploring these parameters during exploratory testing may require complete testing at the OATS or semi-anechoic chamber when the final full spectrum testing is conducted.

The EUT should be set up in its typical configuration and arrangement, and operated in its various modes. For tabletop systems, cables or wires should be manipulated within the range of likely arrangements. For floor-standing equipment, the cables or wires should be located in the same manner as the user would install them and no further manipulation is made. For combination EUTs, the tabletop and floor-standing portions of the EUT shall follow the procedures for their respective setups and cable manipulation. If the manner of cable installation is not known, or if it changes with each installation, cables or wires for floor-standing equipment shall be manipulated to the extent possible to produce the maximum level of emissions.

For each mode of operation required to be tested, the frequency spectrum shall be monitored. Variations in antenna height between 1 and 4 m, antenna polarization, EUT azimuth, and cable or wire placement (each variable within bounds specified elsewhere) shall be explored to produce the emission that has the highest amplitude relative to the limit. A step-by-step technique for determining this emission can be found in Annex C.

When measuring emissions above 1 GHz, the frequencies of maximum emission shall be determined by manually positioning the antenna close to the EUT and by moving the antenna over all sides of the EUT while observing a spectral display. It will be advantageous to have prior knowledge of the frequencies of emissions above 1 GHz. If the EUT is a device with dimensions approximately equal to that of the measurement antenna beamwidth, the measurement antenna shall be aligned with the EUT.



ANSI C63.4 Section 8.3.1.2: **Final radiated emission measurements**

Based on the measurement results in 8.3.1.1, the one EUT, cable and wire arrangement, and mode of operation that produces the emission that has the highest amplitude relative to the limit is selected for the final measurement. The final measurement is then performed on a site meeting the requirements of 5.3, 5.4, or 5.5 as appropriate without variation of the EUT arrangement or EUT mode of operation. If the EUT is relocated from an exploratory test site to a final test site, the highest emission shall be remaximized at the final test location before final radiated emissions measurements are performed. However, antenna height and polarity and EUT azimuth are to be varied. In addition, the full frequency spectrum (for the range to be checked for meeting compliance) shall be investigated.

This investigation is performed with the EUT rotated 360°, the antenna height scanned between 1 m and 4 m, and the antenna rotated to repeat the measurements for both the horizontal and vertical antenna polarizations. During the full frequency spectrum investigation, particular focus should be made on those frequencies found in exploratory testing that were used to find the final test configuration, mode of operation, and arrangement (associated with achieving the least margin with respect to the limit). This full spectrum test constitutes the compliance measurement.

For measurements above 1 GHz, use the cable, EUT arrangement, and mode of operation determined in the exploratory testing to produce the emission that has the highest amplitude relative to the limit. Place the measurement antenna away from each area of the EUT determined to be a source of emissions at the specified measurement distance, while keeping the antenna in the “cone of radiation” from that area and pointed at the area both in azimuth and elevation, with polarization oriented for maximum response. The antenna may have to be higher or lower than the EUT, depending on the EUT’s size and mounting height, but the antenna should be restricted to a range of heights of from 1 m to 4 m above the ground or reference ground plane. If the transmission line for the measurement antenna restricts its range of height and polarization, the steps needed to ensure the correct measurement of the maximum emissions, shall be described in detail in the report of measurements. Data collected shall satisfy the report requirements of Clause 10.

NOTES

- 1— Where limits are specified by agencies for both average and peak (or quasi-peak) detection, if the peak (or quasi-peak) measured value complies with the average limit, it is unnecessary to perform an average measurement.
- 2—Use of waveguide and flexible waveguide may be necessary at frequencies above 10 GHz to achieve usable signal-to noise ratios at required measurement distances. If so, it may be necessary to restrict the height search of the antenna, and special care should be taken to ensure that maximum emissions are correctly measured.
- 3—All presently known devices causing emissions above 10 GHz are physically small compared with the beam-widths of typical horn antennas used for EMC measurements. For such EUTs and frequencies, it may be preferable to vary the height and polarization of the EUT instead of the receiving antenna to maximize the measured emissions.



5.3 Results

30MHz – 1GHz

Antenna: horizontal

EUT: 04GI12b / C01 / TL260GS
Customer:: DSC / Tyco
Test Mode: GSM 850; IDLE
ANT Orientation: H
EUT Orientation: V
Test Engineer: SAM
Voltage: 120v
Comments:

SWEEP TABLE: "CANDA RE_30M-1G_Horz"

Start Frequency	Stop Frequency	Detector	Meas. Time	IF Bandw.	Transducer
30.0 MHz	1.0 GHz	MaxPeak	Coupled	100 kHz	3141-#1186_Horz

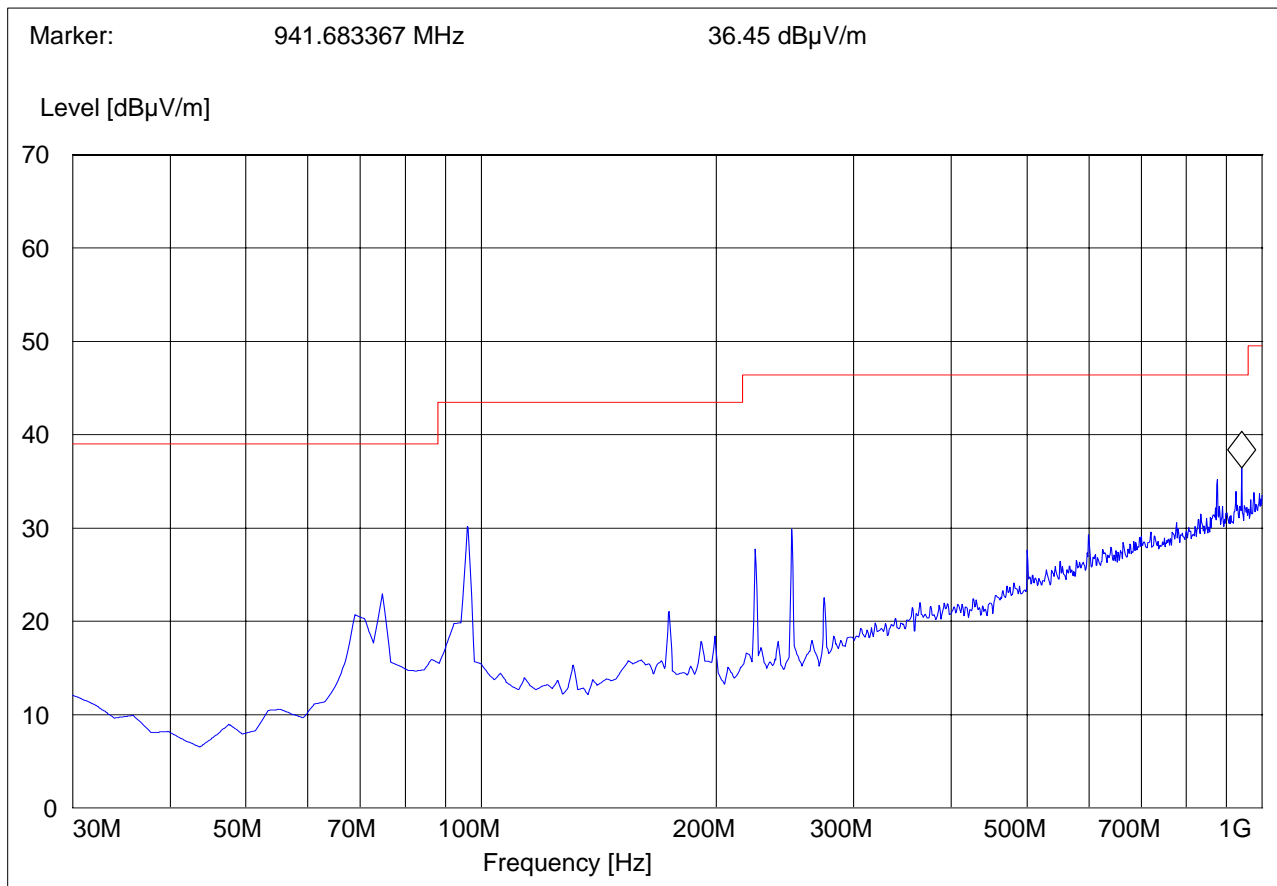



30MHz – 1GHz
Antenna: vertical

EUT: 04GI12b / C01 / TL260GS
Customer:: DSC / Tyco
Test Mode: GSM 850; IDLE
ANT Orientation: V
EUT Orientation: V
Test Engineer: SAM
Voltage: 120v
Comments:

SWEEP TABLE: "CANADA RE_30M-1G_Ver"

Start Frequency	Stop Frequency	Detector	Meas. Time	IF Bandw.	Transducer
30.0 MHz	1.0 GHz	MaxPeak	Coupled	100 kHz	3141-#1186_Vert

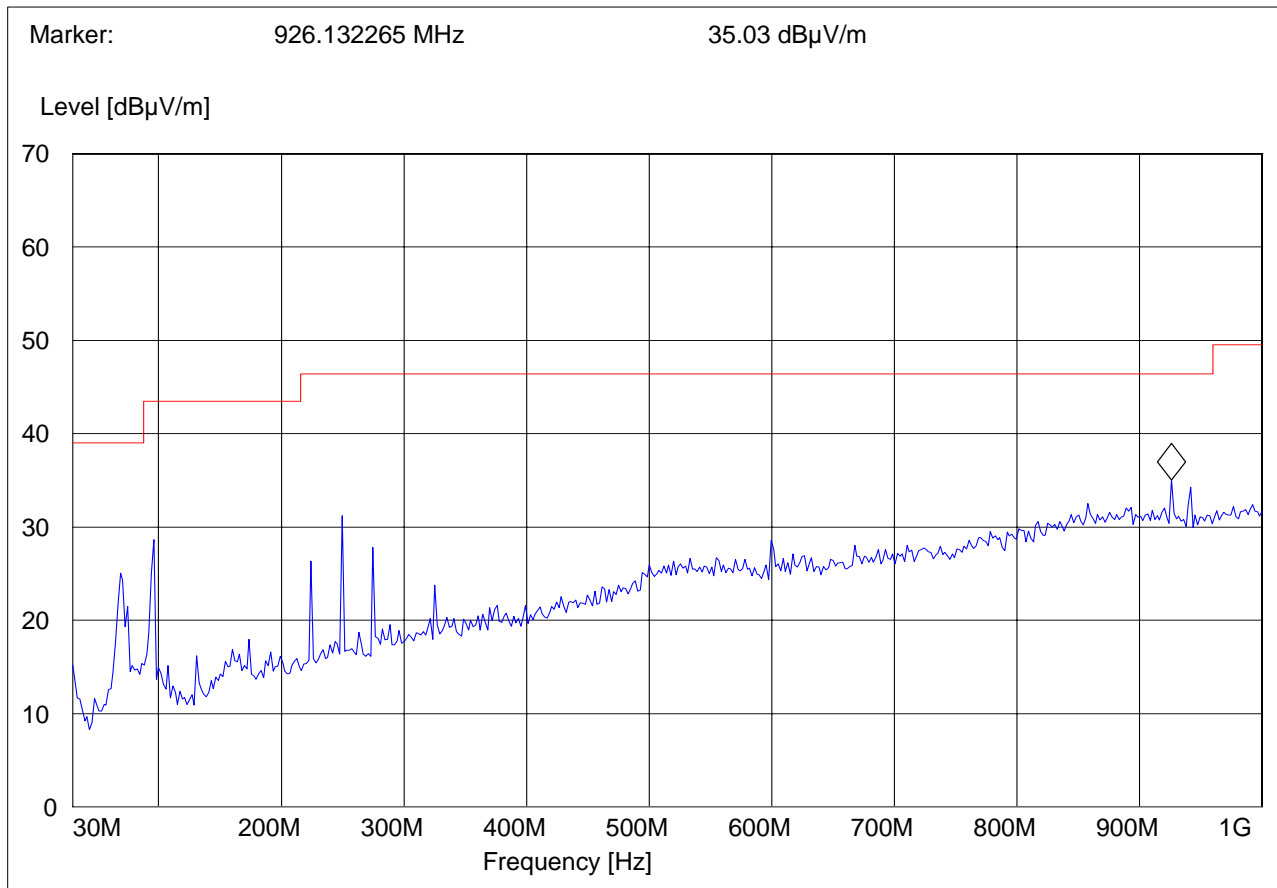



30MHz – 1GHz
Antenna: vertical

EUT: 04GI10 / TL265GS
Customer:: DSC / Tyco
Test Mode: GSM 850; IDLE
ANT Orientation: V
EUT Orientation: V
Test Engineer: Chris
Voltage: 120v
Comments:

SWEEP TABLE: "CANADA RE_30M-1G_Ver"

Start Frequency	Stop Frequency	Detector	Meas. Time	IF Bandw.	Transducer
30.0 MHz	1.0 GHz	MaxPeak	Coupled	100 kHz	3141-#1186_Vert

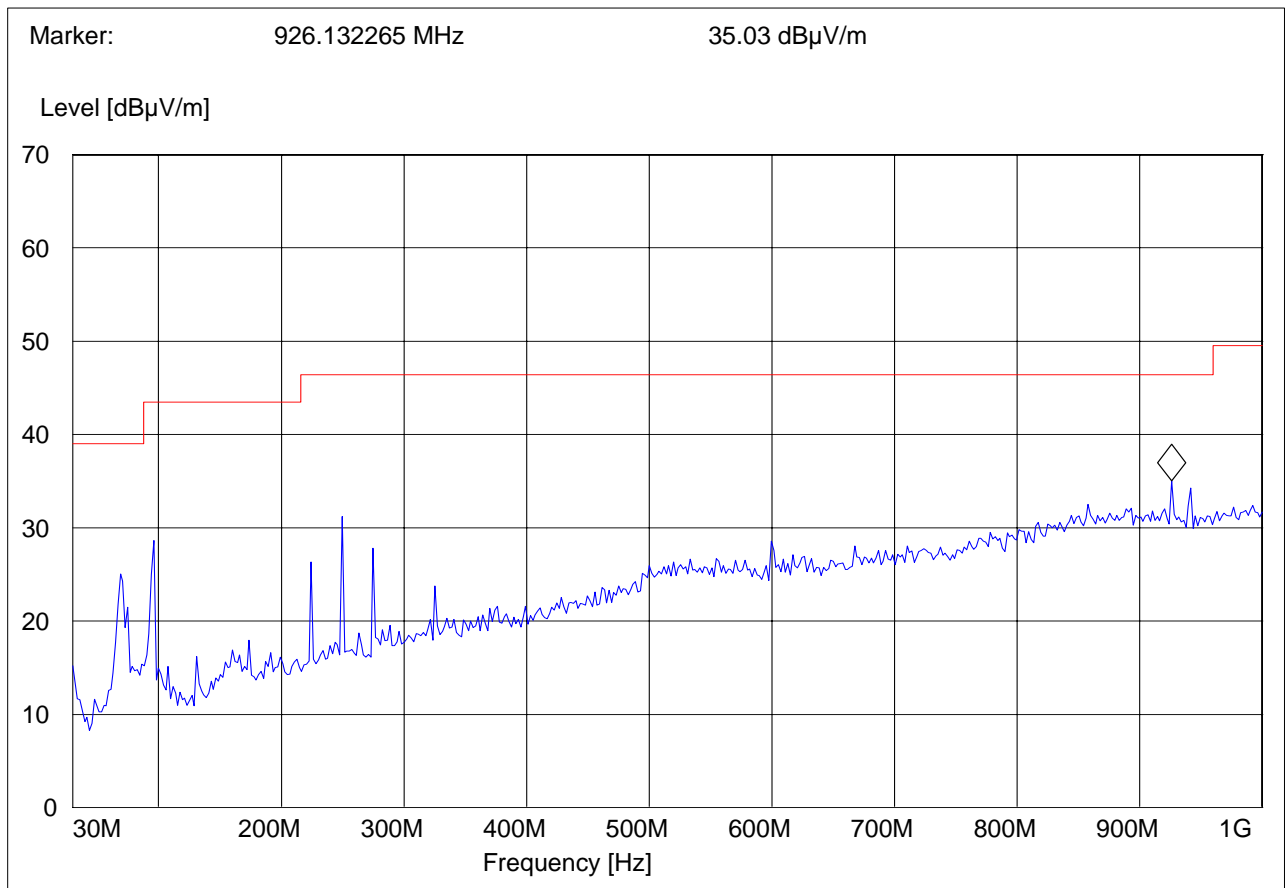



30MHz – 1GHz
Antenna: horizontal

EUT: 04GI10 / TL265GS
Customer:: DSC / Tyco
Test Mode: GSM 850; IDLE
ANT Orientation: H
EUT Orientation: V
Test Engineer: Chris
Voltage: 120v
Comments:

SWEEP TABLE: "CANDA RE_30M-1G_Hor"

Start Frequency	Stop Frequency	Detector	Meas. Time	IF Bandw.	Transducer
30.0 MHz	1.0 GHz	MaxPeak	Coupled	100 kHz	3141-#1186_Horz

Marker: 941.683367 MHz 36.45 dBµV/m

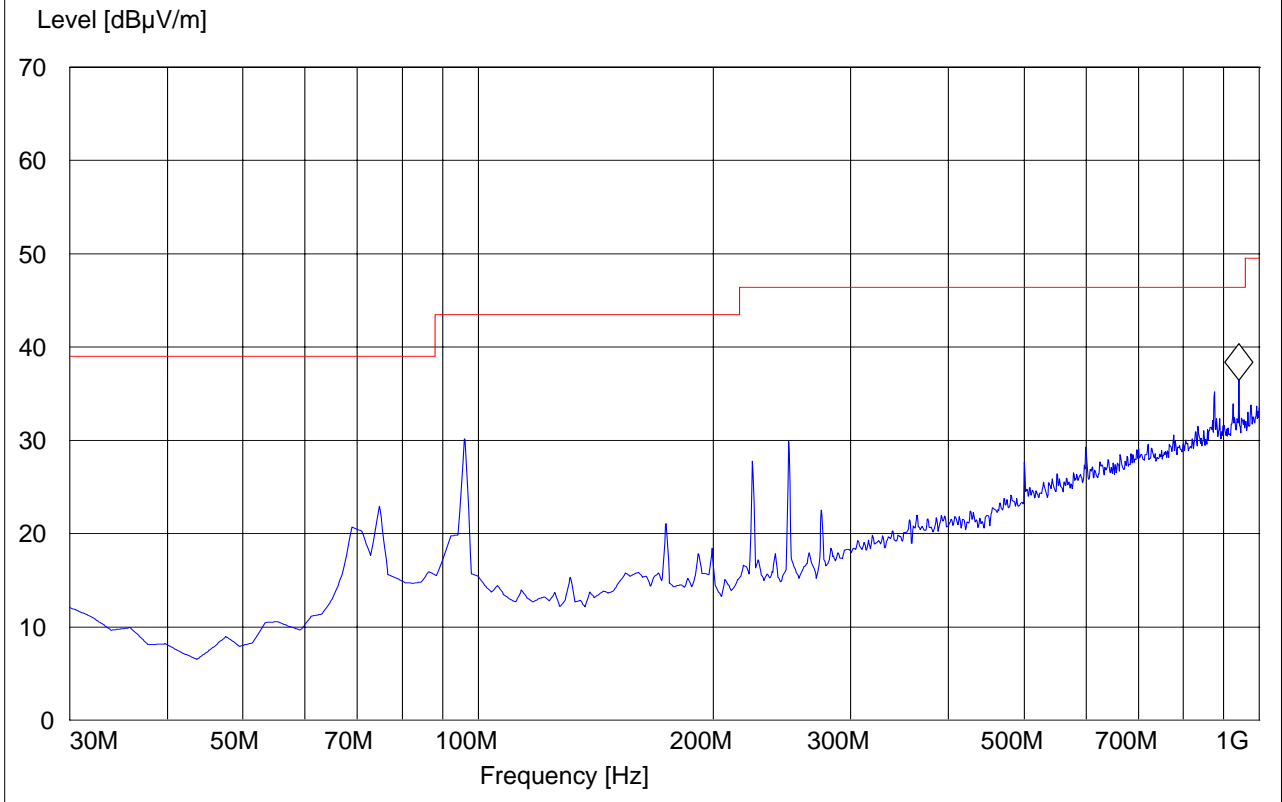



1GHz – 18GHz
Antenna: vertical

EUT / Description: 04GI12b / C01 / TL260GS
Customer: DSC / Tyco
Operation Mode: GSM 850
ANT Orientation: : V
EUT Orientation:: V
Test Engineer: Chris
Voltage: 120VAC and internal battery
Comments::

SWEEP TABLE: "CANADA RE_1-18G"

Start Frequency	Stop Frequency	Detector	Meas. Time	IF Bandw.	Transducer
1.0 GHz	18.0 GHz	MaxPeak	Coupled	1 MHz	#326horn_AF_horz

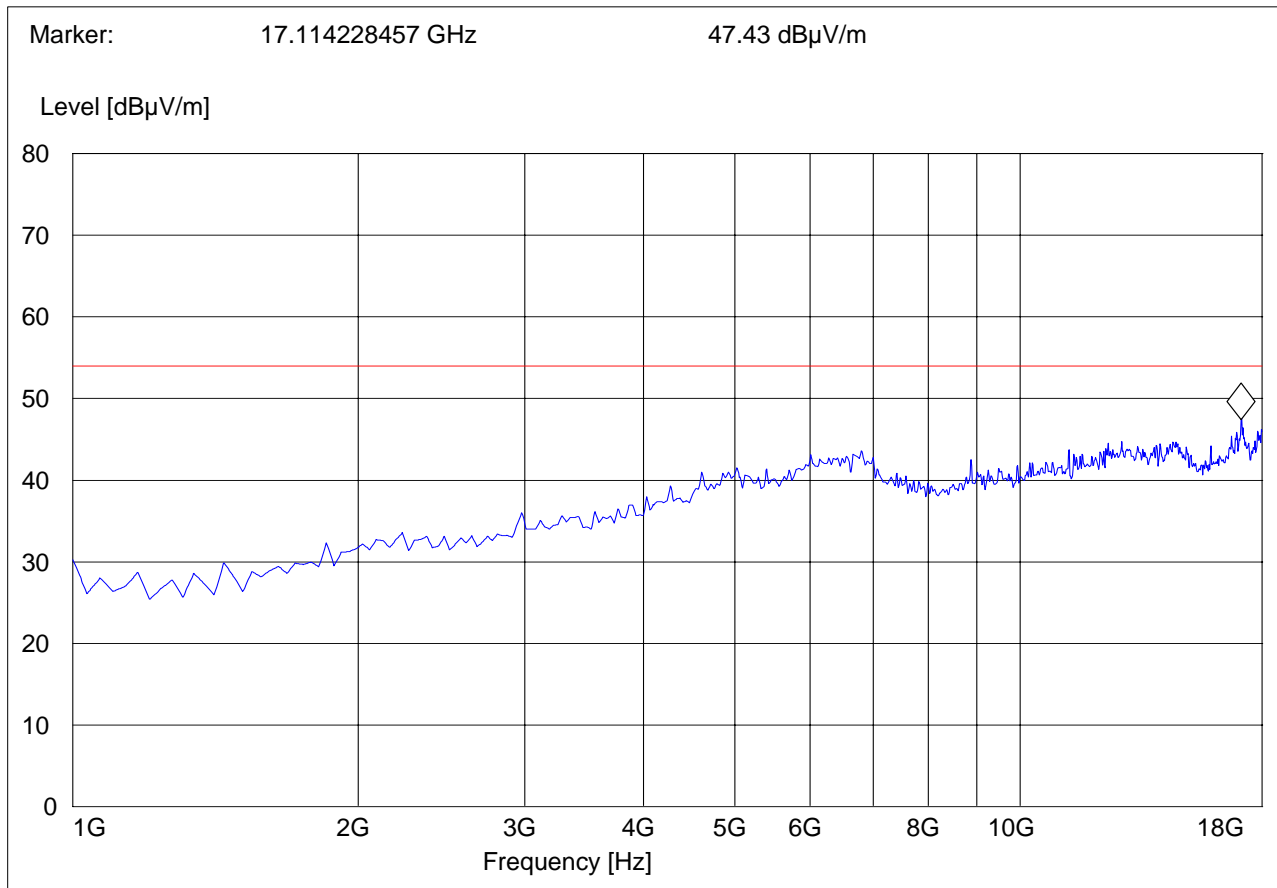



1GHz – 18GHz
Antenna: vertical

EUT / Description: 04GI10 / TL265GS
Customer: Tyco/DSC
Operation Mode: GSM 850
ANT Orientation: V
EUT Orientation: H
Test Engineer: Chris
Voltage: AC Adapter + Internal Battery
Comments:

SWEEP TABLE: "CANADA RE_1-18G"

Start Frequency	Stop Frequency	Detector	Meas. Time	IF Bandw.	Transducer
1.0 GHz	18.0 GHz	MaxPeak	Coupled	1 MHz	#326horn_AF_horz

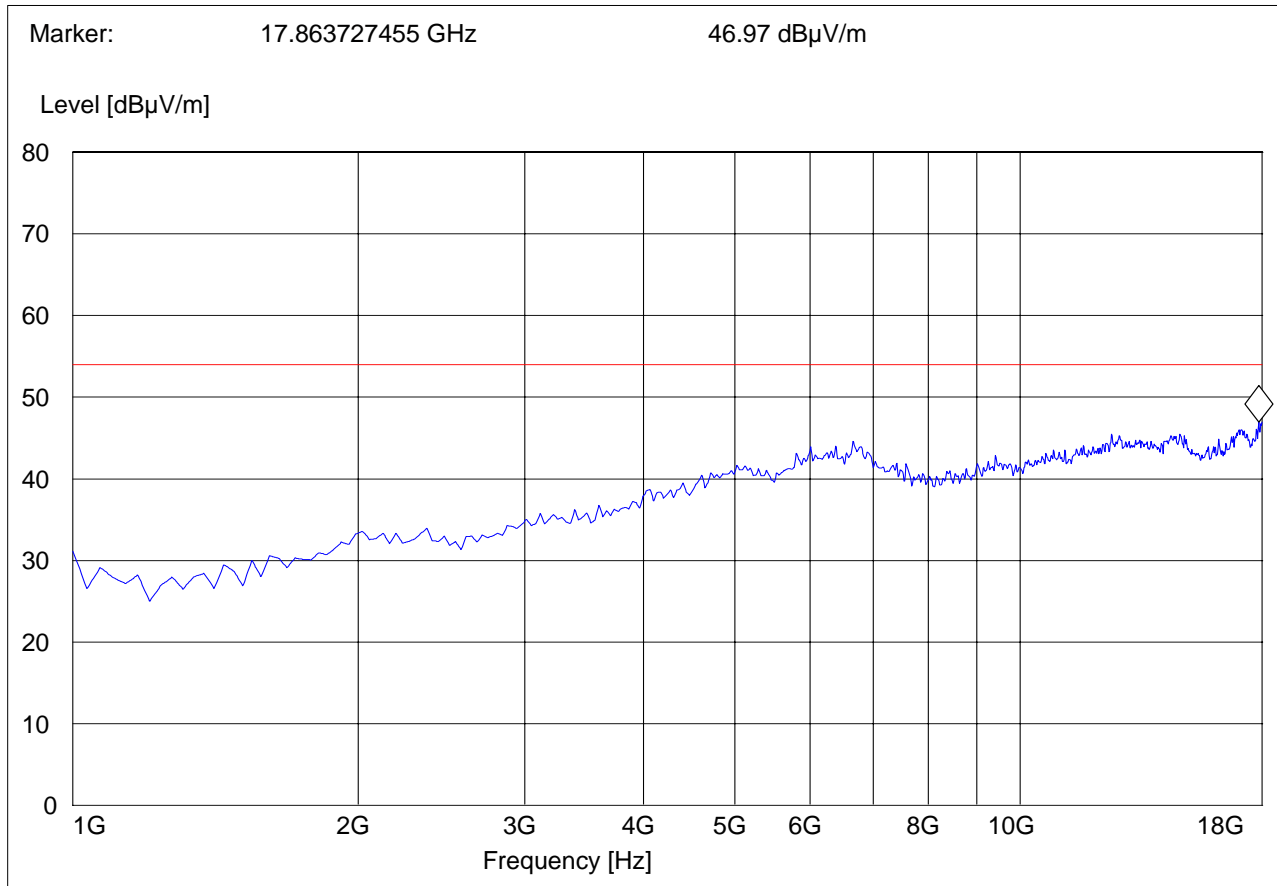



6 AC POWER LINE CONDUCTED EMISSIONS

6.1 LIMIT SUB CLAUSE § 15.207

Technical specification: 15.207 (Revised as of August 20, 2002)

§15.107 (a) Except for Class A digital devices, for equipment that is designed to be connected to the public utility (AC) power line, the radio frequency voltage that is conducted back onto the AC power line on any frequency or frequencies within the band 150 kHz to 30 MHz shall not exceed the limits in the following table, as measured using a 50 µH/50 ohms line impedance stabilization network (LISN). Compliance with the provisions of this paragraph shall be based on the measurement of the radio frequency voltage between each power line and ground at the power terminal. The lower limit applies at the boundary between the frequency ranges.

Limit

Frequency of Emission (MHz)	Conducted Limit (dBµV)	
	Quasi-Peak	Average
0.15 – 0.5	66 to 56*	56 to 46*
0.5 – 5	56	46
5 – 30	60	50

* Decreases with logarithm of the frequency

ANALYZER SETTINGS: RBW = 10KHz

VBW = 10KHz



6.2 RESULTS:

Rx Line

EUT: 04GI12b / C01 / TL260GS
 Manufacturer: DSC / Tyco
 Test Mode: GSM 1900 idle
 ANT Orientation: N/A
 EUT Orientation: H
 Test Engineer: Chris
 Power Supply: 120VAC
 Comments: Line

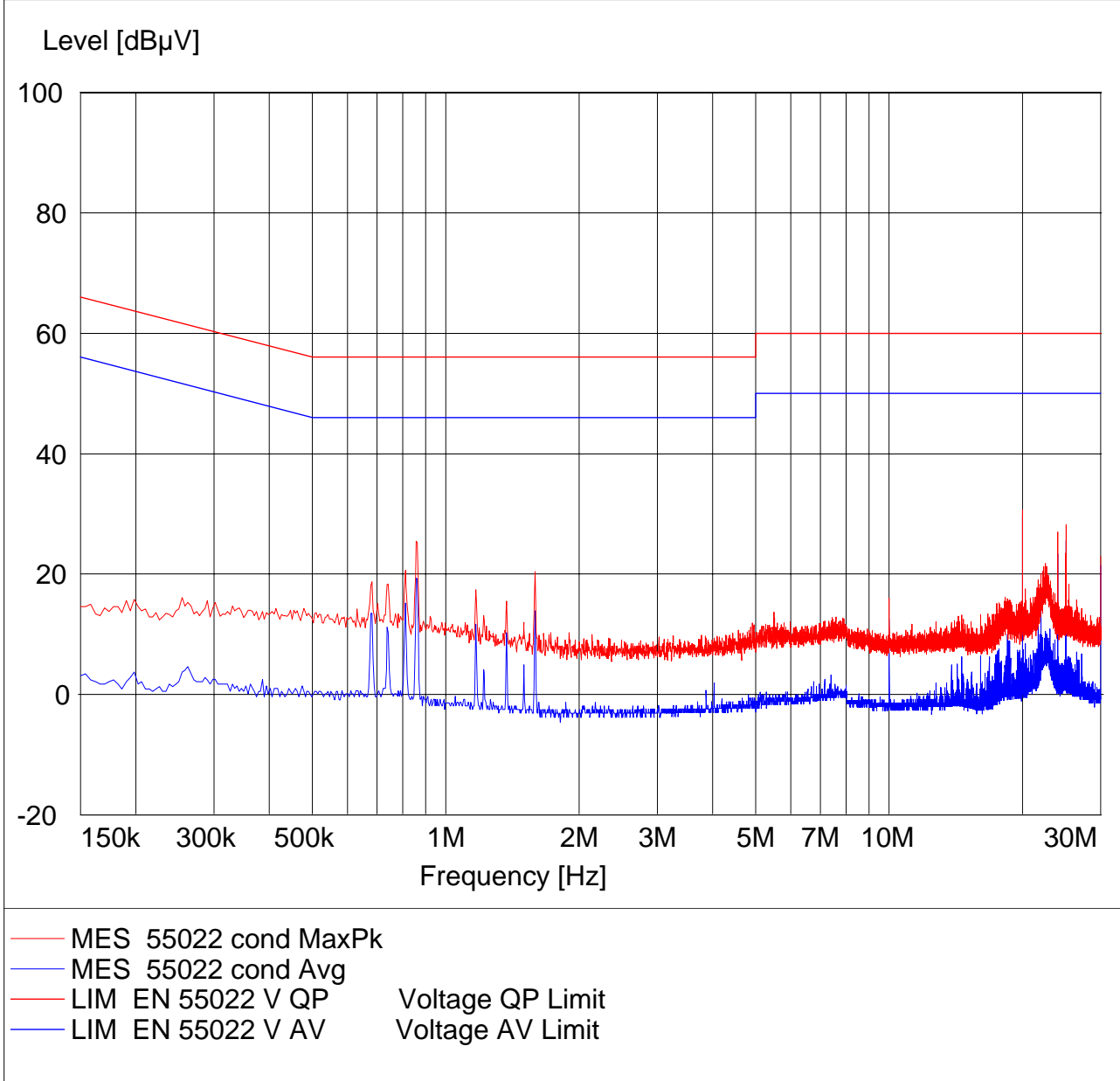

LIMIT LINE: "EN 55022 V AV"

Short Description: Voltage AV Limit
 4/27/1998 2:24PM
 Frequency Level

Test Report #: EMC_TYCOS_014_08001_15B

Date of Report : 2009-01-27

Page 18 of 28



MHz	dBuV
0.150000	56.00
0.500000	46.00
5.000000	46.00
5.000000	50.00
30.000000	50.00

LIMIT LINE: "EN 55022 V QP"

Short Description: Voltage QP Limit
4/27/1998 2:24PM

Frequency MHz	Level dBuV
0.150000	66.00
0.500000	56.00
5.000000	56.00
5.000000	60.00
30.000000	60.00



Rx Neutral

EUT: 04GI12b / C01 / TL260GS
Manufacturer: DSC / Tyco
Test Mode: GSM 1900 idle
ANT Orientation: N/A
EUT Orientation: H
Test Engineer: Chris
Power Supply: 110VAC
Comments: Neutral

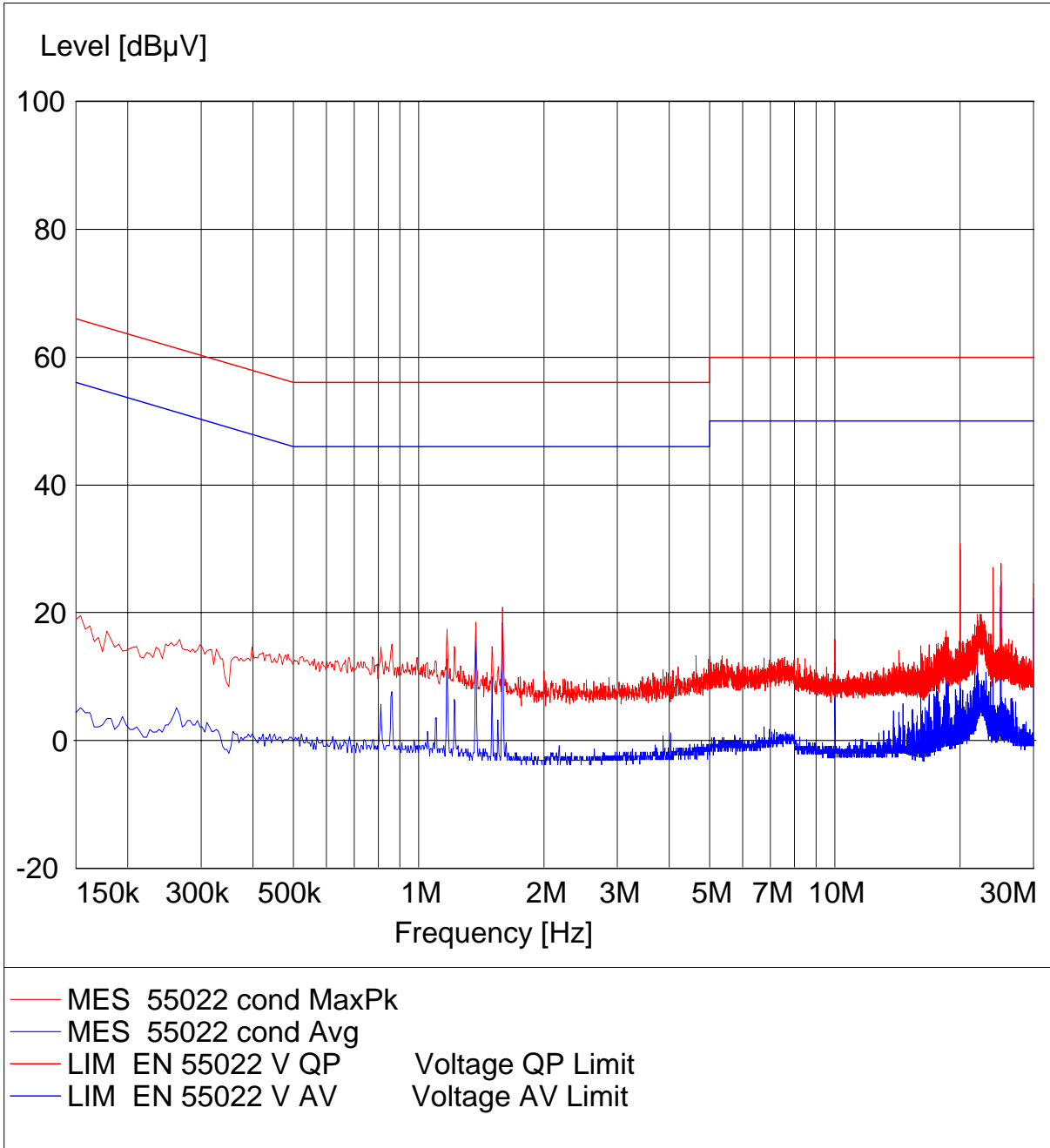



LIMIT LINE: "EN 55022 V AV"

Short Description:	Voltage AV Limit
4/27/1998 2:24PM	
Frequency	Level
MHz	dBuV
0.150000	56.00
0.500000	46.00
5.000000	46.00
5.000000	50.00
30.000000	50.00

LIMIT LINE: "EN 55022 V QP"

Short Description:	Voltage QP Limit
4/27/1998 2:24PM	
Frequency	Level
MHz	dBuV
0.150000	66.00
0.500000	56.00
5.000000	56.00
5.000000	60.00
30.000000	60.00



Rx Line

EUT: 04GI10 / TL265GS
Manufacturer: Tyco/DSC
Test Mode: GSM 850 idle
ANT Orientation: N/A
EUT Orientation: H
Test Engineer: Chris
Power Supply: 120VAC
Comments: Line

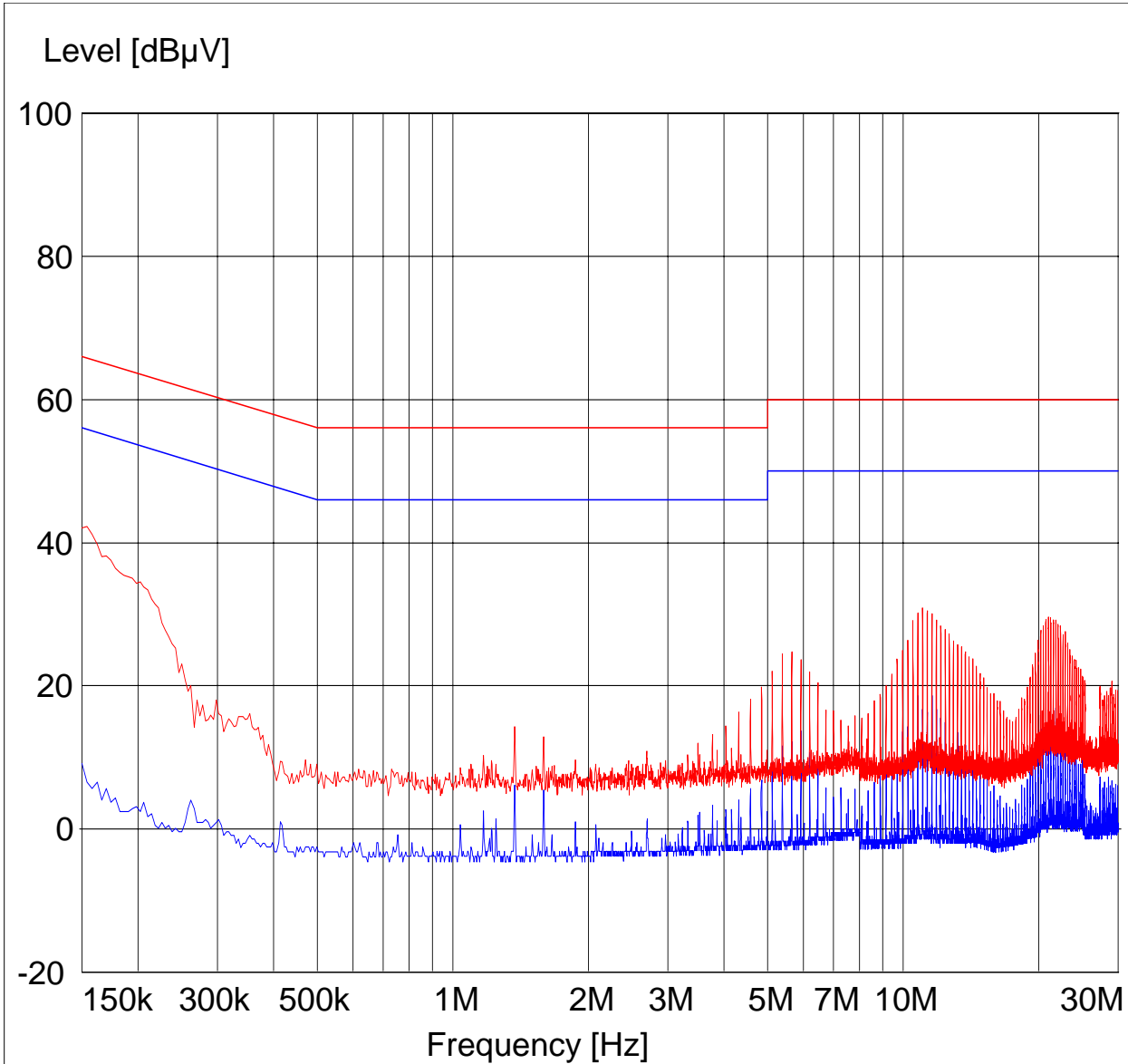

- MES 55022 cond MaxPk
- MES 55022 cond Avg
- LIM EN 55022 V QP Voltage QP Limit
- LIM EN 55022 V AV Voltage AV Limit



LIMIT LINE: "EN 55022 V AV"

Short Description:		Voltage AV Limit
4/27/1998 2:24PM		
Frequency	Level	
MHz	dBuV	
0.150000	56.00	
0.500000	46.00	
5.000000	46.00	
5.000000	50.00	
30.000000	50.00	

LIMIT LINE: "EN 55022 V QP"

Short Description:		Voltage QP Limit
4/27/1998 2:24PM		
Frequency	Level	
MHz	dBuV	
0.150000	66.00	
0.500000	56.00	
5.000000	56.00	
5.000000	60.00	
30.000000	60.00	



Rx Neutral

EUT: 04GI10 / TL265GS
Manufacturer: Tyco/DSC
Test Mode: GSM 850 idle
ANT Orientation: N/A
EUT Orientation: H
Test Engineer: Chris
Power Supply: 120VAC
Comments: Neutral

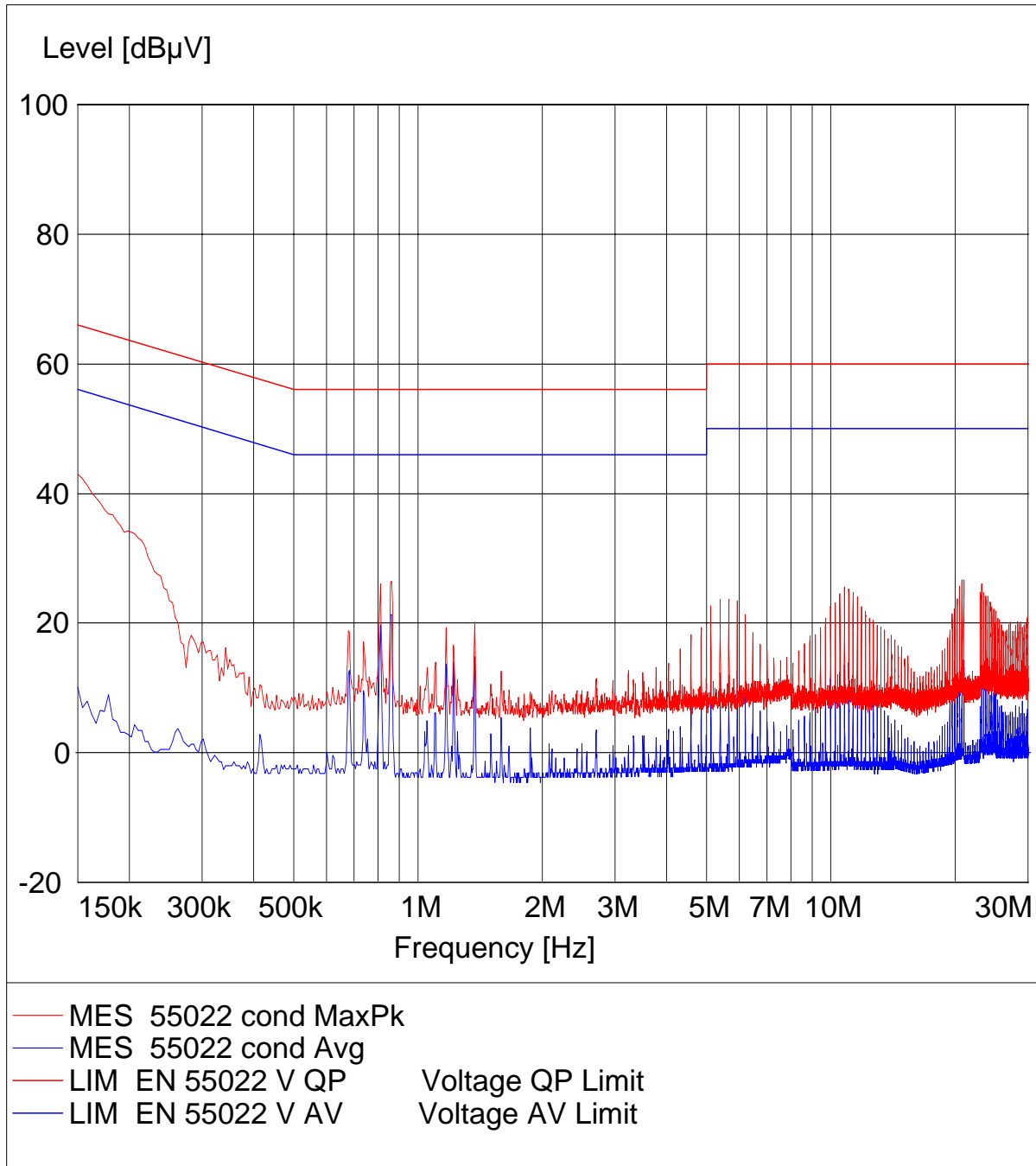



LIMIT LINE: "EN 55022 V AV"

Short Description:		Voltage AV Limit
4/27/1998 2:24PM		
Frequency	Level	
MHz	dBuV	
0.150000	56.00	
0.500000	46.00	
5.000000	46.00	
5.000000	50.00	
30.000000	50.00	

LIMIT LINE: "EN 55022 V QP"

Short Description:		Voltage QP Limit
4/27/1998 2:24PM		
Frequency	Level	
MHz	dBuV	
0.150000	66.00	
0.500000	56.00	
5.000000	56.00	
5.000000	60.00	
30.000000	60.00	



7 TEST EQUIPMENT AND ANCILLARIES USED FOR TESTS

No	Instrument/Ancillary	Type	Manufacturer	Serial No.	Cal Due	Interval
01	Spectrum Analyzer	ESIB 40	Rohde & Schwarz	100107	May 2009	1 year
02	Spectrum Analyzer	FSEM 30	Rohde & Schwarz	100017	May 2009	1 year
03	Signal Generator	SMY02	Rohde & Schwarz	836878/011	May 2009	1 year
04	Power-Meter	NRVD	Rohde & Schwarz	0857.8008.02	May 2009	1 year
05	Biconilog Antenna	3141	EMCO	0005-1186	June 2009	1 year
06	Horn Antenna (1-18GHz)	SAS-200/571	AH Systems	325	June 2009	1 year
07	Horn Antenna (18-26.5GHz)	3160-09	EMCO	1240	June 2009	1 year
08	Power Splitter	11667B	Hewlett Packard	645348	n/a	n/a
09	Climatic Chamber	VT4004	Voltsch	G1115	May 2009	1 year
10	High Pass Filter	5HC2700	Trilithic Inc.	9926013	n/a	n/a
11	High Pass Filter	4HC1600	Trilithic Inc.	9922307	n/a	n/a
12	Pre-Amplifier	JS4-00102600	Miteq	00616	May 2009	1 year
13	Power Sensor	URV5-Z2	Rohde & Schwarz	DE30807	May 2009	1 year
14	Universal Radio Comm. Tester	CMU 200	Rohde & Schwarz	832221/06	May 2009	1 year
15	LISN	ESH3-Z5	Rohde & Schwarz	836679/003	May 2009	1 year
16	Loop Antenna	6512	EMCO	00049838	July 2010	2 years

8 BLOCK DIAGRAMS

Conducted Testing

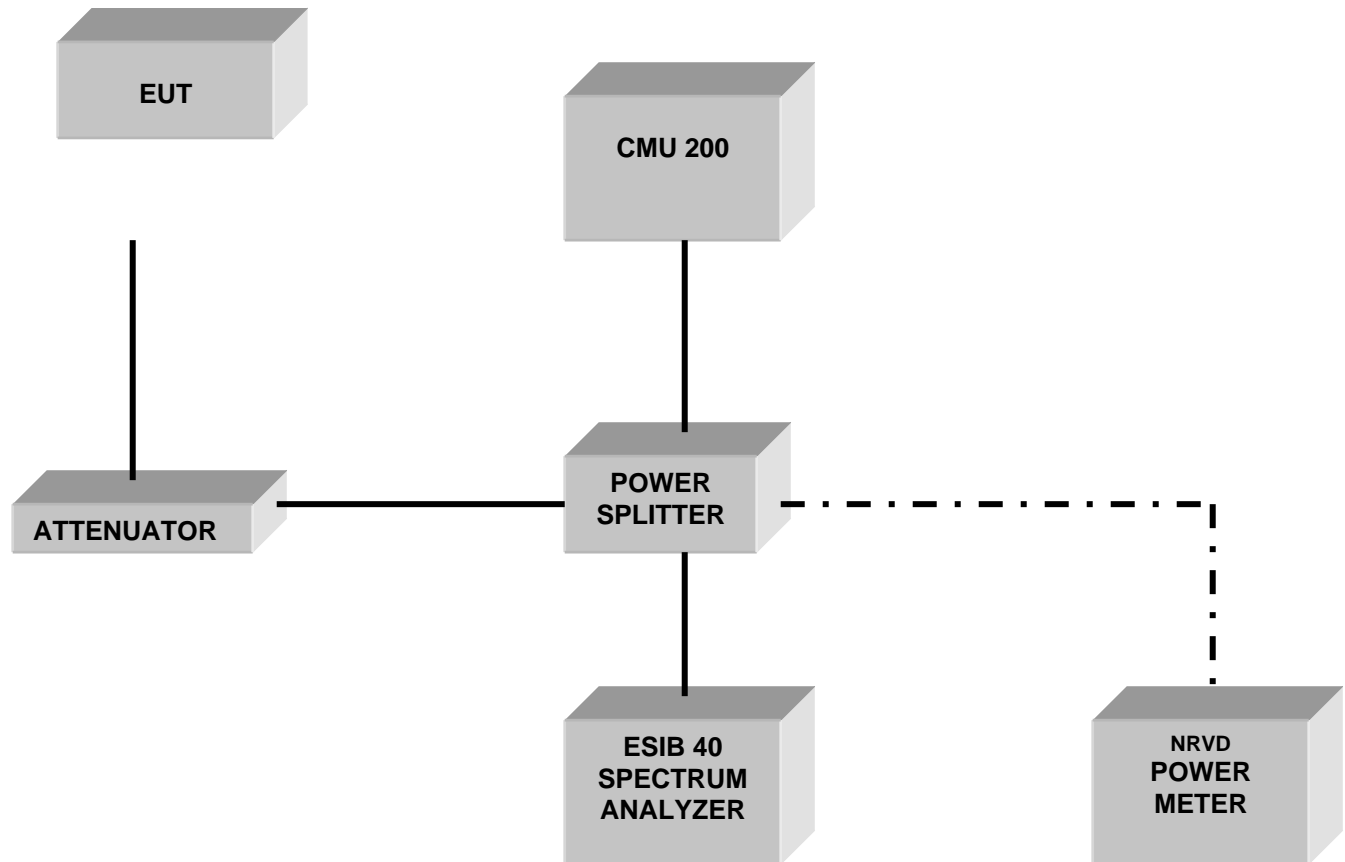

Radiated Testing

ANECHOIC CHAMBER

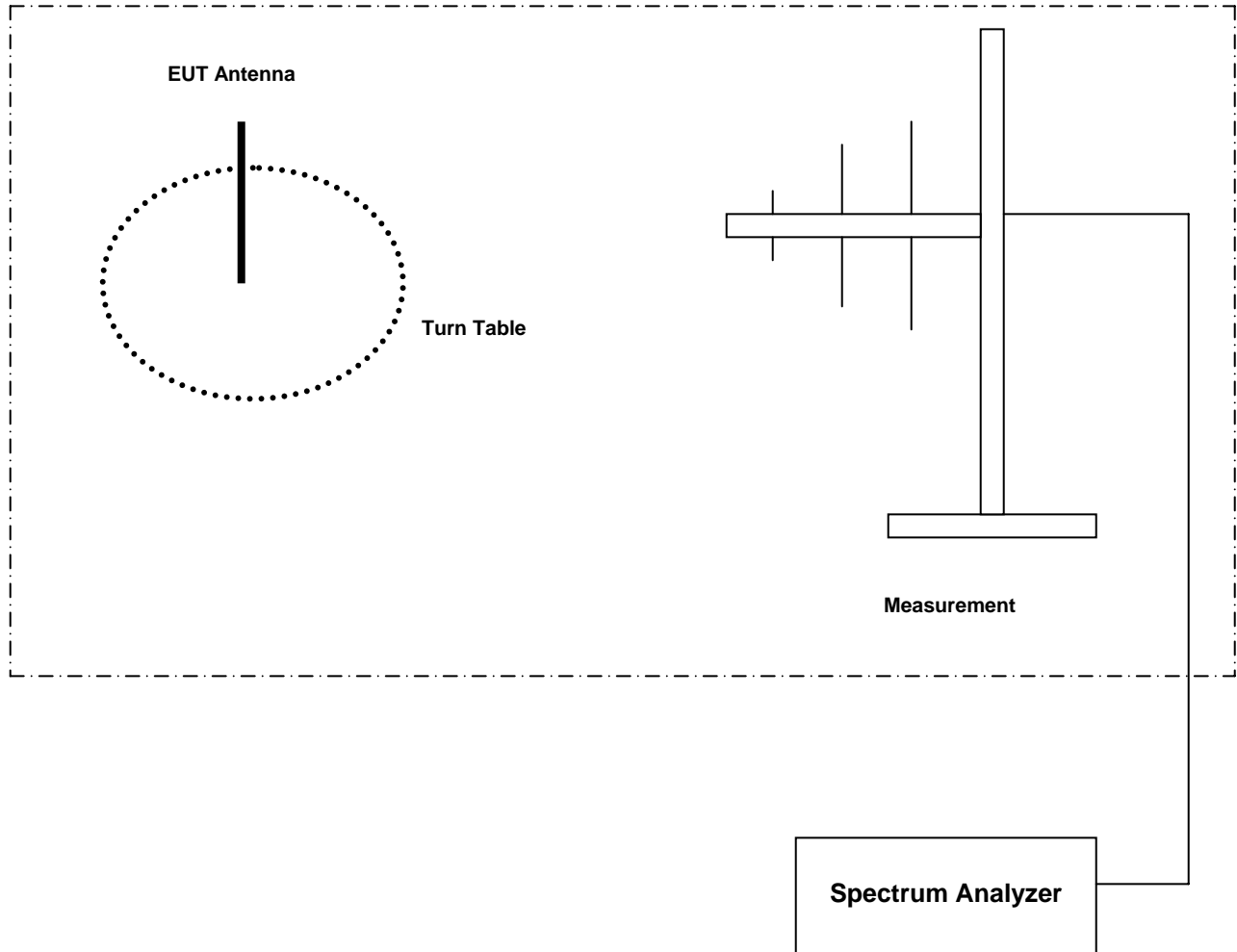

Test Report #: EMC_TYCOS_014_08001_15B

Date of Report : 2009-01-27

Page 28 of 28



9 Report History

2009-01-28 Original Report