



Test Report: 2W04794

Applicant: Digital Security Controls Ltd.
3301 Langstaff Road
Concord Ontario
L4K 4L2

**Equipment Under Test:
(EUT)** UA352 Rev 01X3

FCC ID: F5302RF5501433

In Accordance With: **FCC 47 CFR Part 15, Subpart B: 1999, Including R&O 989-80, Class B Certification**

Tested By: Nemko Canada Inc.
303 River Road, R.R. 5
Ottawa, Ontario K1V 1H2

Authorized By:

A handwritten signature in blue ink, appearing to read 'John Harrington'.

J. Harrington, RF Group Manager

Date: 24 July 2002

Total Number of Pages: 23

EQUIPMENT: UA352 Rev 01X3

FCC ID: F5302RF5501433

Table Of Contents

Section 1. Summary of Test Results.....	3
Section 2. Equipment Under Test (EUT).....	6
Section 3. Equipment Configuration	9
Section 4. Conducted Emissions.....	11
Section 5. Radiated Emissions.....	17
Section 6. Sample Calculations.....	20
Section 7. Block Diagrams.....	21
Section 8. Test Equipment List	23
Annex A Prescans For Engineering Evaluation Only.....	A1

EQUIPMENT: UA352 Rev 01X3
FCC ID: F5302RF5501433

Section 1. Summary of Test Results

General:

All measurements are traceable to national standards.

These tests were conducted on a sample of the equipment for the purpose of demonstrating compliance with FCC Part 15, Subpart B for Class B Digital Devices.

These tests were conducted using measurement procedures of CISPR 22: 1997-11.

The equipment was tested for conducted emissions from 0.15 MHz to 30 MHz using a 50 microhenry line impedance stabilization network (L.I.S.N.) as described in CISPR 22: 1997-11. Peripheral equipment was also operated through a 50 microhenry L.I.S.N.

Abstract:

Name Of Test	Para. No.	Results
Conducted Emissions	R&O 989-80, 15.107	Complied
Radiated Emissions	15.109	Complied

THIS TEST REPORT APPLIES ONLY TO THE ITEM(S) TESTED.



Test Performed By: _____
Kevin Carr, EMC Specialist

Date: 24 July 2002

Nemko Canada Inc., a testing laboratory, is accredited by the Standards Council of Canada. The tests included in this report are within the scope of this accreditation.

Nemko Canada Inc. authorizes the above named company to reproduce this report provided it is reproduced in its entirety and for use by the company's employees only.

Any use which a third party makes of this report, or any reliance on or decisions to be made based on it, are the responsibility of such third parties. Nemko Canada Inc. accepts no responsibility for damages, if any, suffered by any third party as a result of decisions made or actions based on this report. This report applies only to the items tested.

EQUIPMENT: UA352 Rev 01X3
 FCC ID: F5302RF5501433

Measurement Uncertainty

Accuracy of Measurement

The measurement uncertainty was calculated using the methods described in NAMAS document NIS81 May 1994, with the confidence level of 95%.

Radiated Measurements

OATS #1 (A) 3 meter [UN9902B]

Contribution	Distribution	Uncertainty (+/-)
Field Strength Variation	Random	0.2089 dB μ V ²
Measurement Equipment	Normal	0.3275 dB μ V ²
Measurement Equipment	Rectangular	0.4167 dB μ V ²
Total Combined Uncertainty		0.9762 dB μ V ²

Expanded Uncertainty @ 95% Confidence = ± 2.0013 dBmV

OATS #1 (B) 10 meter [UN9906B]

Contribution	Distribution	Uncertainty (+/-)
Field Strength Variation	Random	0.1388 dB μ V ²
Measurement Equipment	Normal	0.3275 dB μ V ²
Measurement Equipment	Rectangular	0.4167 dB μ V ²
Total Combined Uncertainty		0.9694 dB μ V ²

Expanded Uncertainty @ 95% Confidence = ± 1.926 dBmV

OATS #2 (B) 3 meter [UN9912B]

Contribution	Distribution	Uncertainty (+/-)
Field Strength Variation	Random	0.4516 dB μ V ²
Measurement Equipment	Normal	0.3275 dB μ V ²
Measurement Equipment	Rectangular	0.4167 dB μ V ²
Total Combined Uncertainty		1.0935 dB μ V ²

Expanded Uncertainty @ 95% Confidence = ± 2.2417 dBmV

EQUIPMENT: UA352 Rev 01X3
FCC ID: F5302RF5501433

Radiated Measurements, continued

OATS #2 (C) 10 meter [UN9917B]

Contribution	Distribution	Uncertainty (+/-)
Field Strength Variation	Random	0.1211 dBμV ²
Measurement Equipment	Normal	0.3275 dBμV ²
Measurement Equipment	Rectangular	0.4167 dBμV ²
Total Combined Uncertainty		0.9302 dBμV ²

Expanded Uncertainty @ 95% Confidence = ± 1.9069 dBmV

Conducted Measurements

Shielded Room #1 [UN9920]

Contribution	Distribution	Uncertainty (+/-)
Amplitude Variation	Random	0.0400 dBμV ²
Measurement Equipment	Normal	0.7500 dBμV ²
Measurement Equipment	Rectangular	0.2500 dBμV ²
Total Combined Uncertainty		1.0198 dBμV ²

Expanded Uncertainty @ 95% Confidence = ± 2.0396 dBmV

EQUIPMENT: UA352 Rev 01X3
FCC ID: F5302RF5501433

Theory of Operation

The RF5501-433 allows the user to access the security system as they would be able to from any other keypad on the system. The RF5501-433 is able to receive the signals from our wireless devices and decode them for the control panel.

EQUIPMENT: UA352 Rev 01X3
FCC ID: F5302RF5501433

Justification

The EUT was configured for testing as per typical installation. Position and bundling of cables were investigated to establish maximum amplitude of emissions.

The following combinations were investigated to establish worst case configuration:

- (1) The EUT was tested as per normal operation
- (2) The EUT contains a 13.225625MHz crystal.
- (3) To generate the Local Osc. frequency, the EUT incorporates the following multiplication factor, $6.6128125\text{MHz} \times 64$. The Local Osc. Frequency is 423.22MHz.

Exercise Program

The EUT exercise program used during radiated and conducted testing was designed to exercise the various system components in a manner similar to typical use. The software used during testing was Ver. 5

Exercise Mode:

- (1) The EUT was tested in a armed, away state.

EQUIPMENT: UA352 Rev 01X3
 FCC ID: F5302RF5501433

Section 3. Equipment Configuration

Equipment Configuration List:

Item	Description	FCC ID	Model No.	Serial No.	Rev.
(A)	EUT, LCD keypad and Receiver	F5302RF5501433	UA352	None	01X3
(B)	Control Card		PC5010	None	06MA
(C)	DC Feed and Ring-Up Unit		CLI-043	FA000194	

Equipment Ports:

Item	Description	Number
(i)	Comm. Buss	1
(ii)	POTS Port	1
(iii)	AC Port	1

Inter-Connection Cables:

Item	Description	Length (m)
(1)	4-Conductor, 22AWG, UTP	2.0
(2)	4-Conductor POTS Cable, UTP	2.0
(3)	Standard North American Power Cord	2.0

EQUIPMENT: UA352 Rev 01X3
FCC ID: F5302RF5501433

Configuration of the Equipment Under Test (EUT)

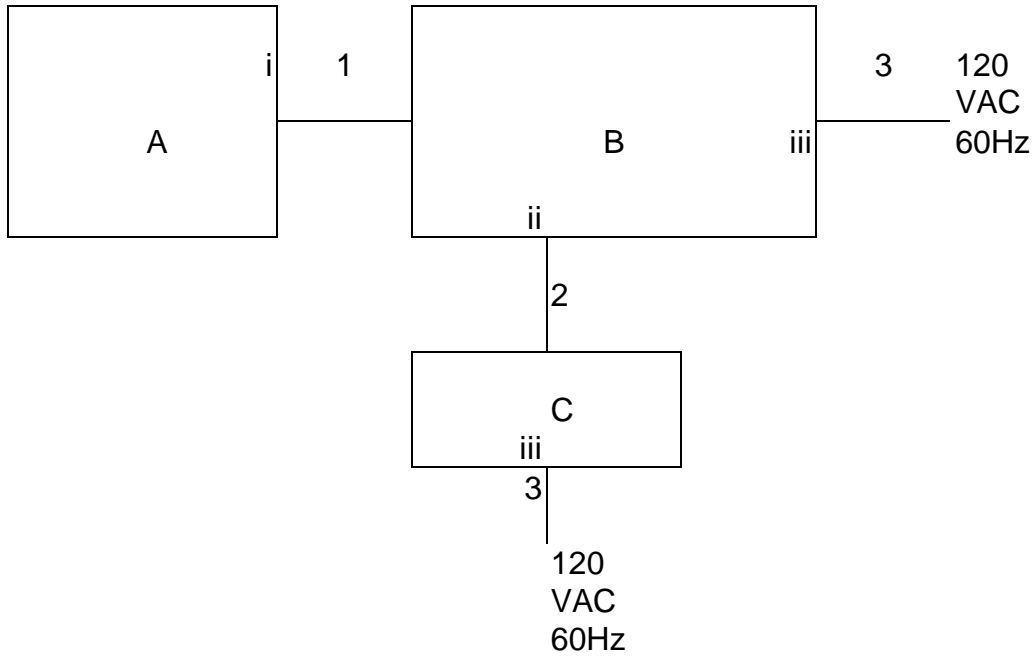

EQUIPMENT: UA352 Rev 01X3
 FCC ID: F5302RF5501433

Section 4. Conducted Emissions

Para. No.: R&O 989-80, 15.107

Test Performed By: Kevin Carr	Date of Test: 2 July 2002
--------------------------------------	----------------------------------

Test Conditions: Test Voltage: 120VAC
 Temperature: 23°C
 Humidity: 51%

Minimum Standard:

Frequency Range MHz	Limits for Conducted Disturbance at a Mains Ports of Class B		
	Quasi-Peak Limits dB (µV)	Average Limits dB (µV)	Required
0.15 to 0.5	66 to 56	56 to 46	<input checked="" type="checkbox"/>
0.5 to 5	56	46	<input checked="" type="checkbox"/>
5 to 30	60	50	<input checked="" type="checkbox"/>

Notes:
 The lower limit shall apply at the transition frequency.
 The limit decreases linearly with the logarithm of the frequency in the range 0.15 MHz to 0.5 MHz for Class B

Test Results: Complied. See attached graphs and table.

Measurement Data: See attached graphs and table.

Method Of Measurement: (Procedure CISPR 22: 1997-11)

Measurements were made using a spectrum analyzer with 10 kHz RBW, Peak detector. Any emissions that were close to the limit were measured using a test receiver with 10 kHz bandwidth, CISPR Quasi-Peak detector.

All emissions within 10 dB of limit have been recorded.

EQUIPMENT: UA352 Rev 01X3

FCC ID: F5302RF5501433

Measurement Data

Test Data:

Tested as per Table Top <input checked="" type="checkbox"/>			Tested as per Floor Standing <input type="checkbox"/>			
The top six emissions within 20 dB of the limit have been recorded/plotted.						
No.	Conductor	Frequency (MHz)	Detector	Level (dBµV)	Limit (dBµV)	Margin (dB)
1	Phase	0.150	Quasi-Peak	54.2	66.0	11.8
			Average	10.2	56.0	45.8
2	Phase	0.180	Quasi-Peak	54.0	64.5	10.5
			Average	9.3	54.5	45.2
3	Phase	0.200	Quasi-Peak	52.8	63.6	10.8
			Average	40.0	53.6	13.6
4	Neutral	0.150	Quasi-Peak	55.0	66.0	11.0
			Average	9.8	56.0	46.2
5	Neutral	0.180	Quasi-Peak	53.7	64.5	10.8
			Average	9.3	54.5	45.2
6	Neutral	0.200	Quasi-Peak	52.7	63.6	10.9
			Average	22.1	53.6	31.5
Notes:						

EQUIPMENT: UA352 Rev 01X3
 FCC ID: F5302RF5501433

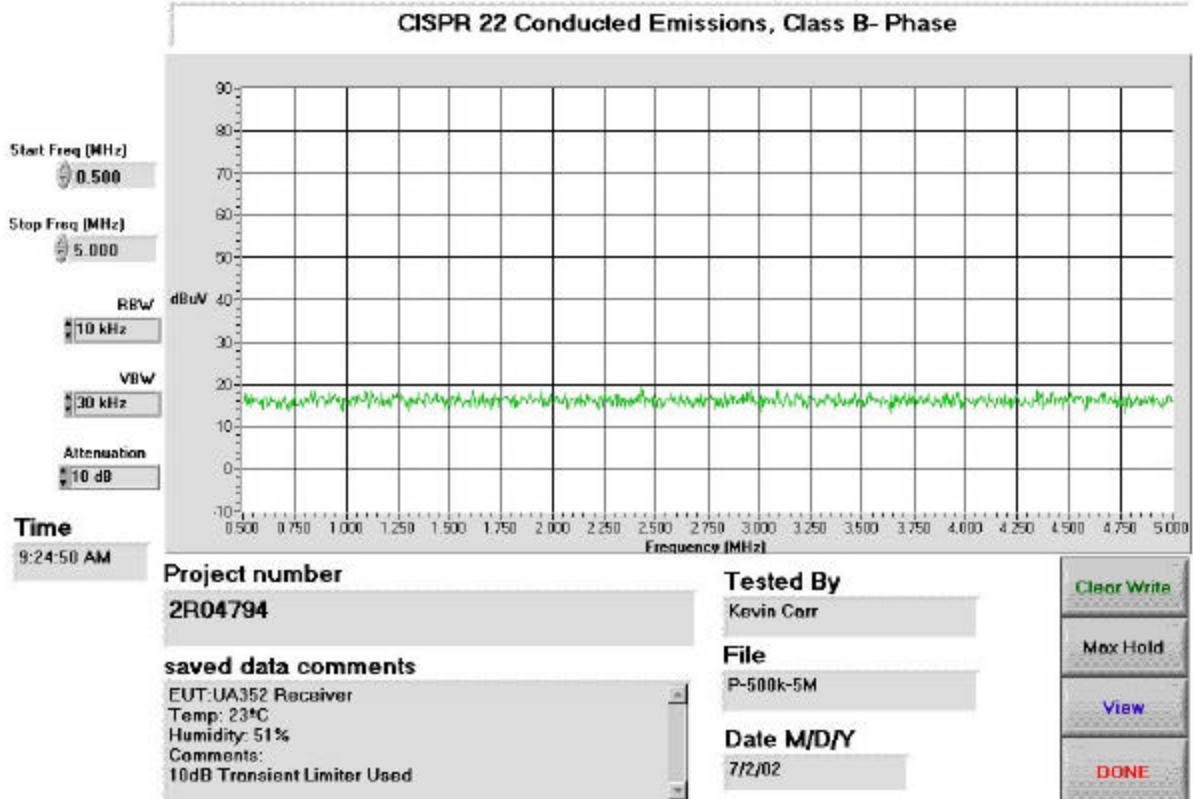
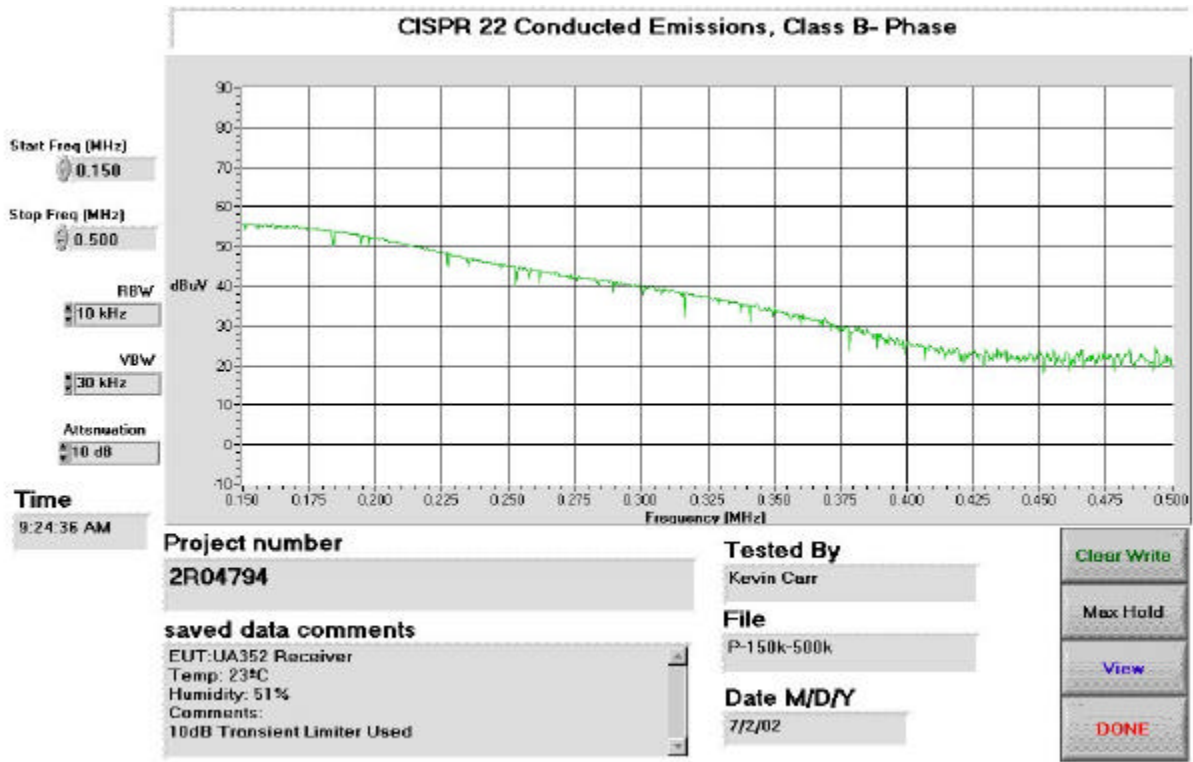

EQUIPMENT: UA352 Rev 01X3
FCC ID: F5302RF5501433

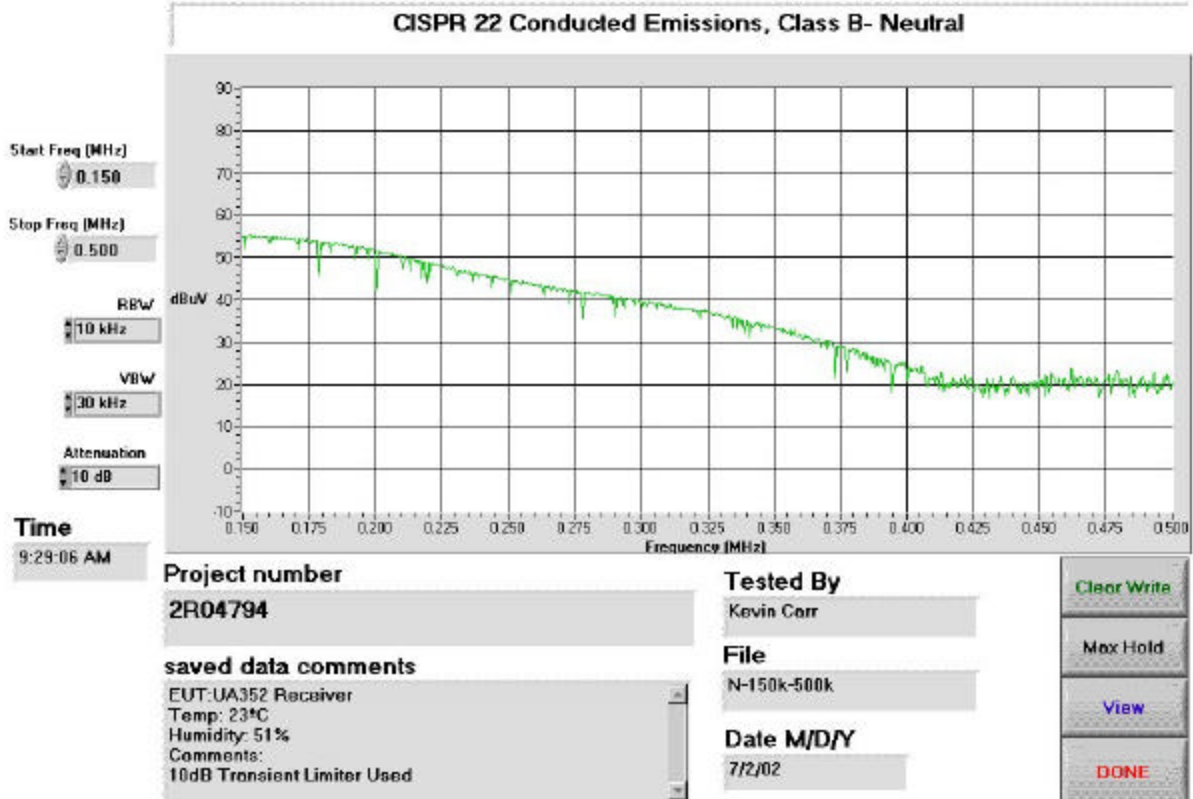
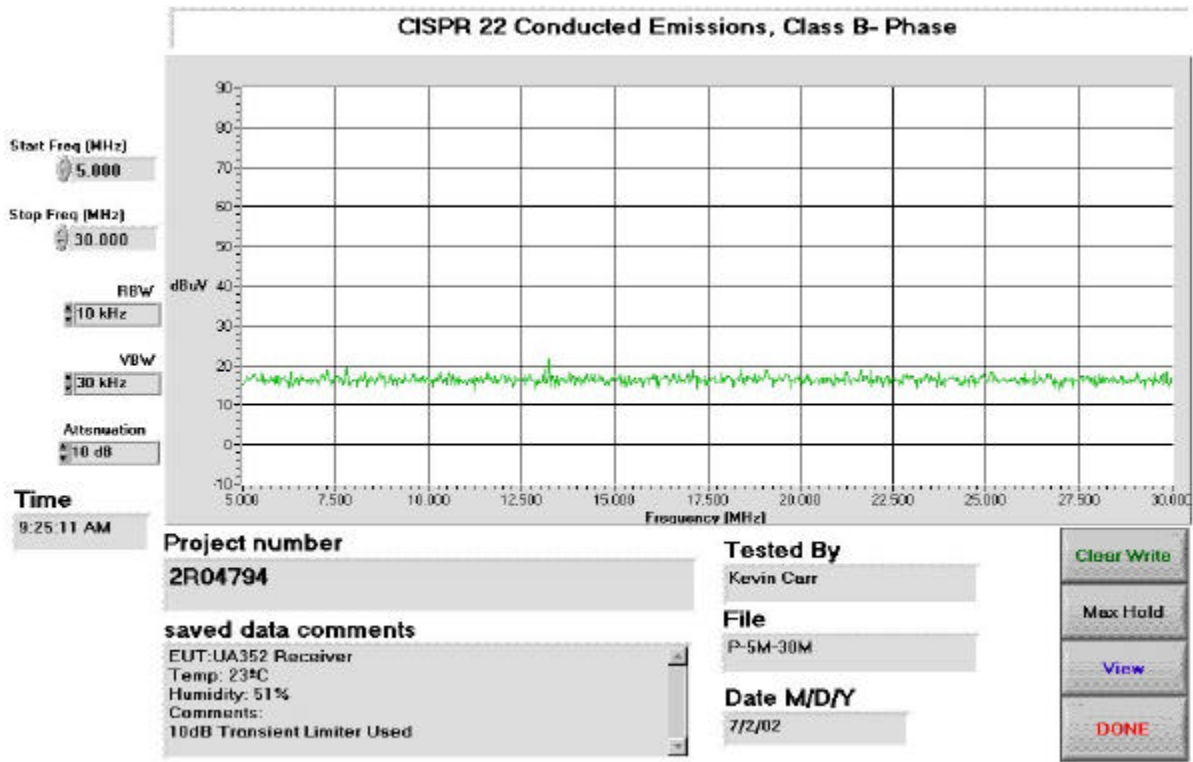

EQUIPMENT: UA352 Rev 01X3
FCC ID: F5302RF5501433

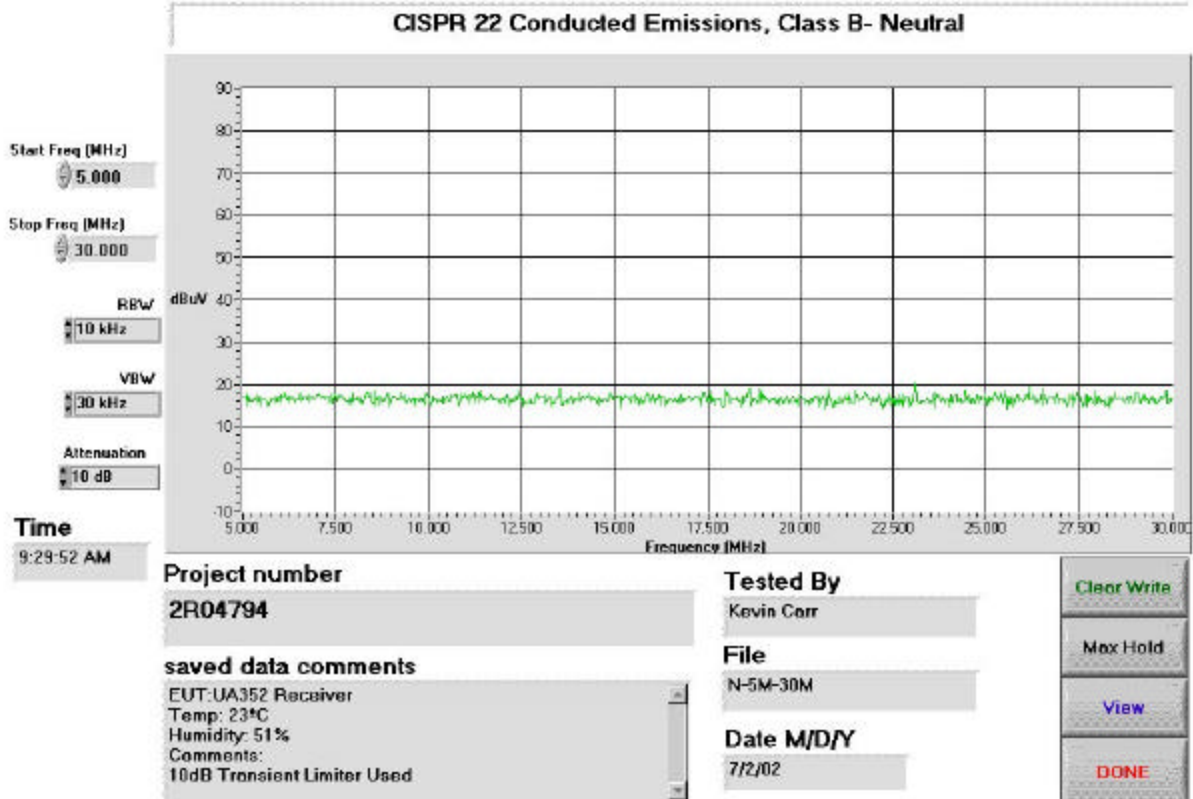
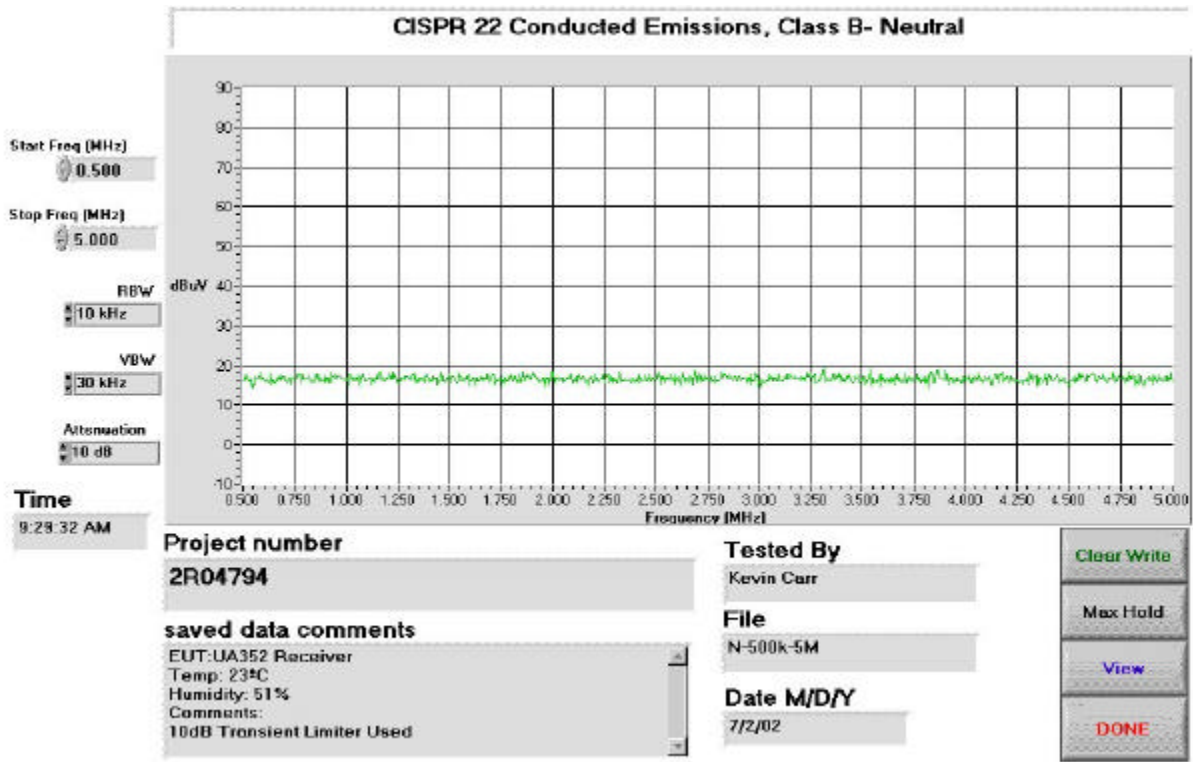

EQUIPMENT: UA352 Rev 01X3
FCC ID: F5302RF5501433

Conducted Photographs

Front View

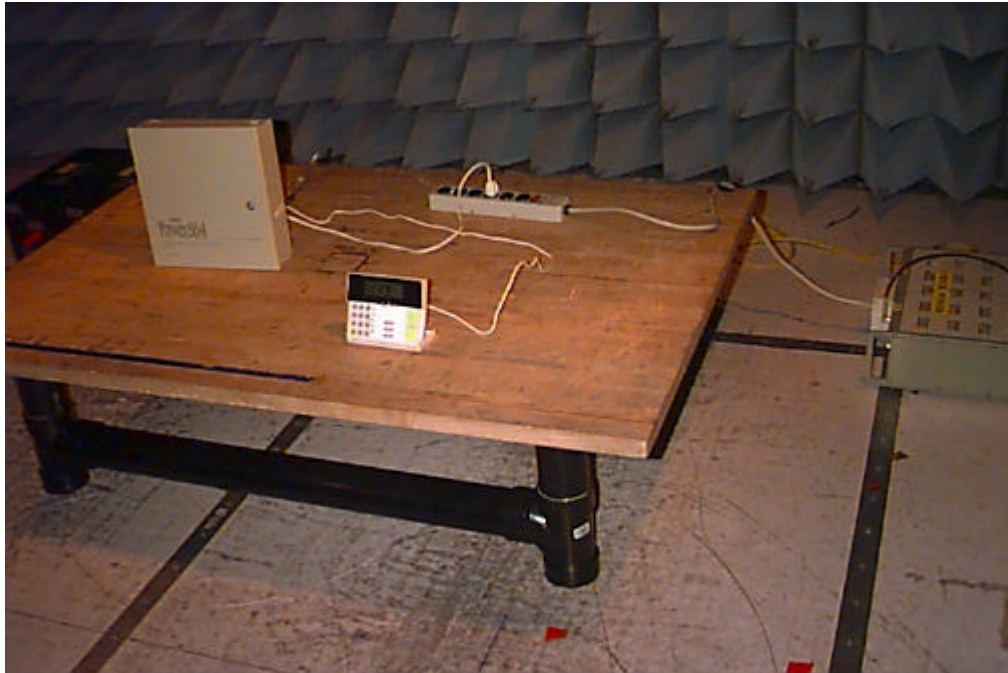

Side View

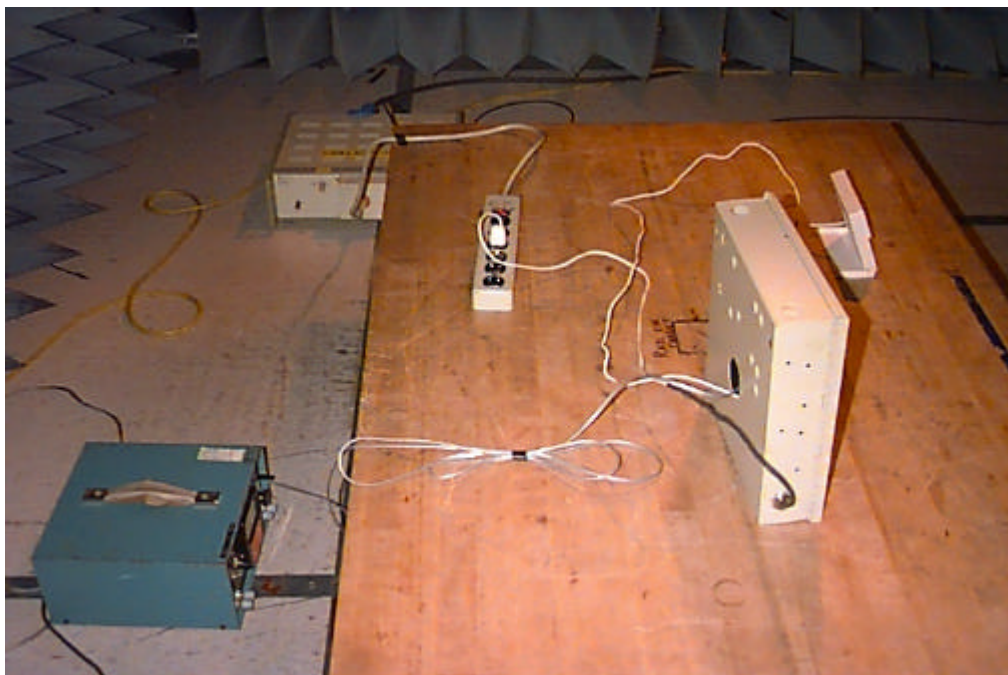

EQUIPMENT: UA352 Rev 01X3
FCC ID: F5302RF5501433

Section 5. Radiated Emissions

Para. No.: 15.109

Test Performed By: Kevin Carr	Date of Test: 2 July 2002
--------------------------------------	----------------------------------

Test Conditions: Test Voltage: 120VAC
Temperature: 33°C
Humidity: 65%

Minimum Standard:

Frequency (MHz)	Maximum Field Strength at 3m	
	µV/m	dBµV/m
30 - 88	100	40.0
88 - 216	150	43.5
216 - 960	200	46.0
Above 960	500	54.0

Test Results: Complied. The worst-case emission level was 29.5dBµV/m @ 3m at 66.13 MHz. This was 10.5dB below the specification limit.

EQUIPMENT: UA352 Rev 01X3
 FCC ID: F5302RF5501433

Measurement Data:

The equipment was prescanned in a shielded room using a spectrum analyzer and broadband antenna. A list of frequencies was compiled for investigation in the open field. The equipment was then moved to an open area test site where amplitude measurements were made at a distance of 3 meters. The bandwidth was set to 120 kHz and the detector function was CISPR Quasi-Peak. Any emission within 3 dB of the specification limit is re-measured using a reference tuned dipole antenna per ANSI C63.4.

Emissions detected above 1 GHz were measured with horn antenna and low noise pre-amplifier at a distance of 3 meters.

The spectrum was investigated from 30MHz up to the frequency shown in the following table.

Highest Frequency Generated or Used in the Device Which the Device Operates or Tunes (MHz)	Upper Frequency of Measurement Range (MHz)
Below 1.075	30
1.705 – 108	1000
108 – 500	2000
500 – 1000	5000
Above 1000	5 th harmonic of the highest frequency or 40 GHz, whichever is lower.

The highest operational frequency used in the EUT was 432.22 MHz.
 The top six (6) emissions within 20 dB of the limit have been recorded.

Test Data - Radiated Emissions

Test Distance (meters) : 3		Range: a		Receiver: esvp			RBW(kHz): 120		Detector: CISPR Q-PEAK	
No.	Freq. (MHz)	Ant.	Pol (V/H)	RCVD Signal (dBµV/m)	Ant. Factor (dB)**	Amp. Gain (dB)***	Dist. Corr. (dB)	Field Strength (dBµV/m)	Limit (dBµV/m)	Margin (dB)
1	46.0	B/C1	V	16.9	12			28.9	40	11.1
2	47.95	B/C1	V	15.4	11.7			27.1	40	12.9
3	52.9	B/C1	V	12.3	11			23.3	40	16.7
4	53.249	B/C1	V	15.4	10.9			26.3	40	13.7
5	66.13	B/C1	H	19.6	9.9			29.5	40	10.5
6	423.22	L/P1	V	14.5	19			33.5	46	12.5

Notes:

B/C = Biconical, BL = Bilog, L/P = Log-Periodic, H = Horn, D/P = Dipole, E/D = EMCO Dipole
 * Re-measured using dipole antenna.
 ** Includes cable loss when amplifier is not used.
 *** Includes cable loss.
 () Denotes failing emission level.
 N.D. = Not Detected

EQUIPMENT: UA352 Rev 01X3
FCC ID: F5302RF5501433

Radiated Photographs

Front View

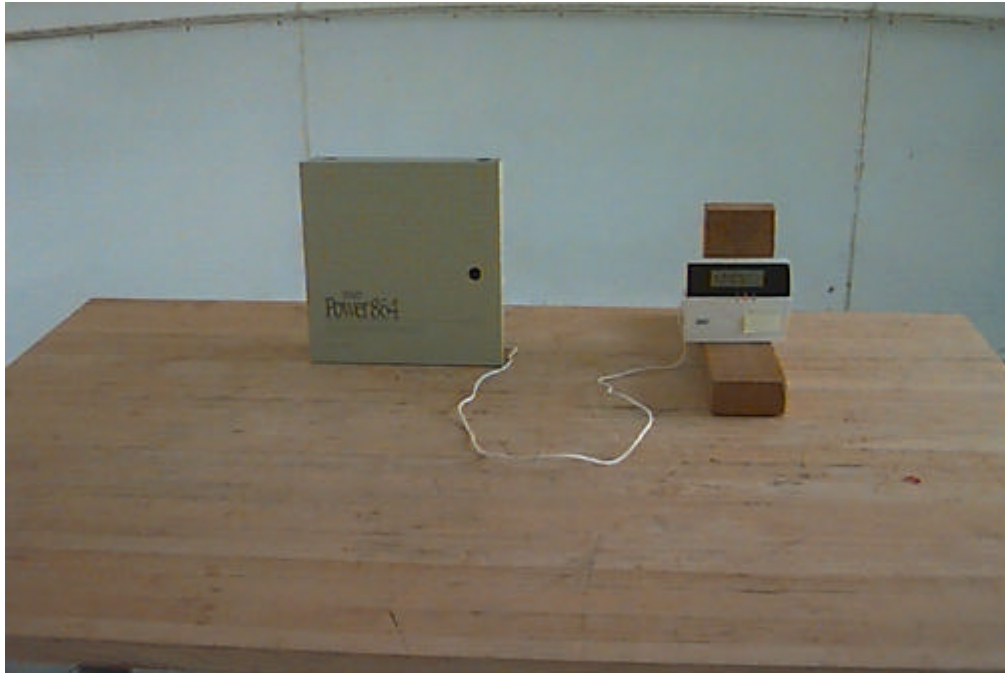

Rear View

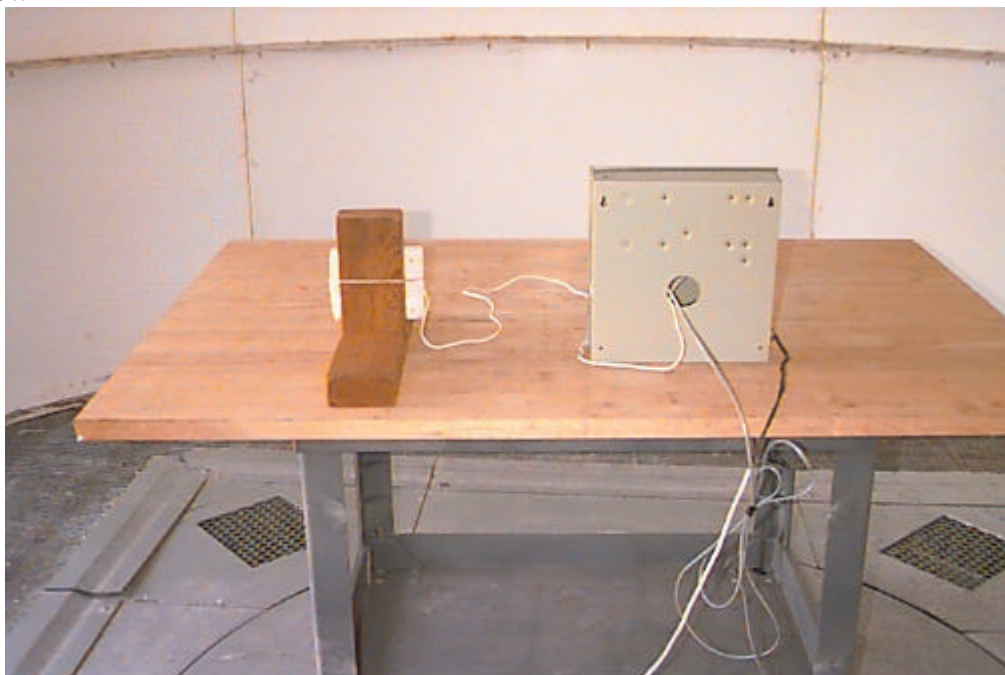

EQUIPMENT: UA352 Rev 01X3

FCC ID: F5302RF5501433

Section 6. Sample Calculations

Radiated Emissions

Emissions were measured at a distance of 3 meters and corrected for antenna factor and cable loss.

i.e. Received Signal = 25 dB μ V @ 100 MHz
 Antenna Factor & Cable Loss = 9.8 dB
 Field Intensity = 25 + 9.8 = 34.8 dB μ V/m @ 3 m

EQUIPMENT: UA352 Rev 01X3

FCC ID: F5302RF5501433

Section 7. Block Diagrams

Conducted Emissions

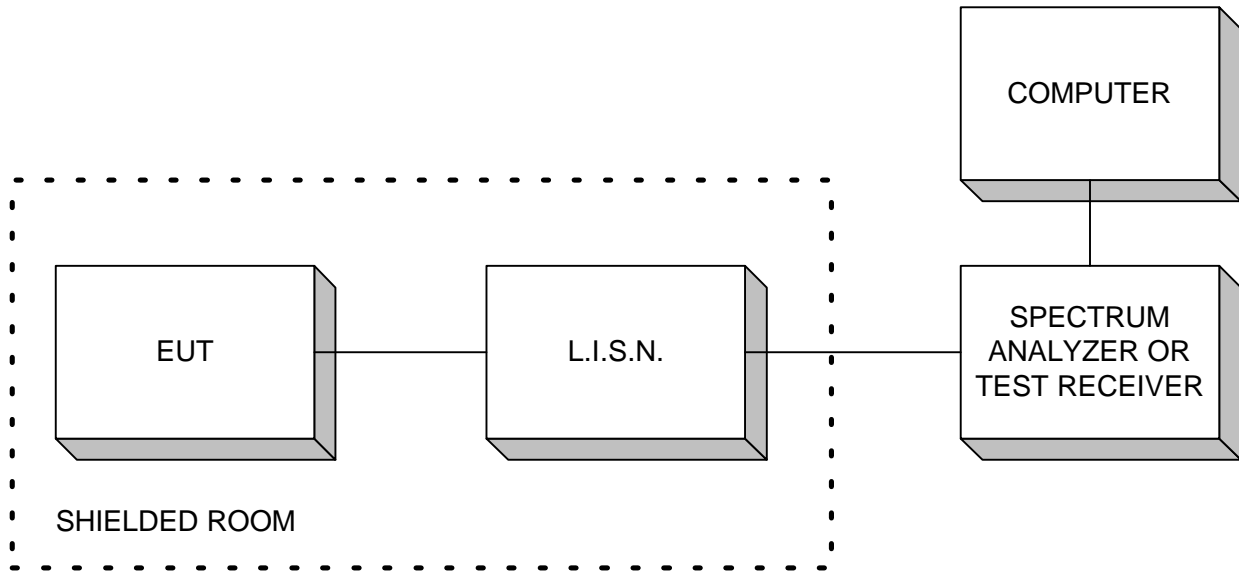

Radiated Prescan

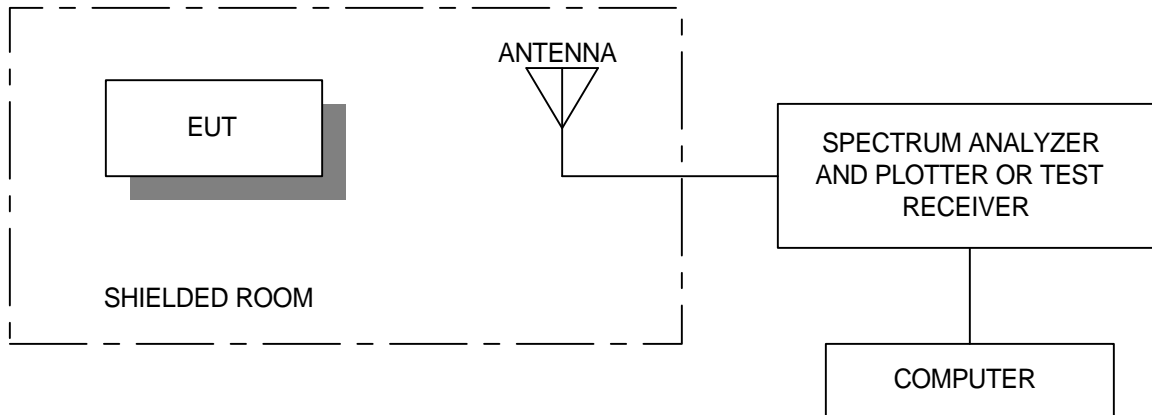

EQUIPMENT: UA352 Rev 01X3
FCC ID: F5302RF5501433

Outdoor Test Site For Radiated Emissions

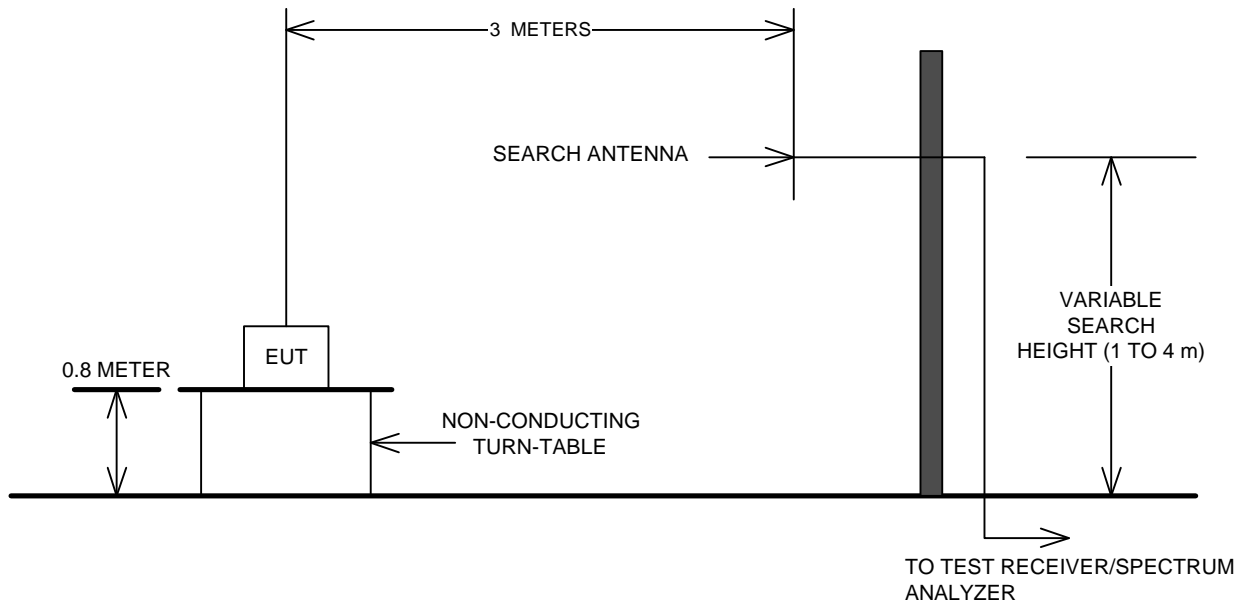

The spectrum was searched up to 1GHz or the 5th harmonic of the highest oscillator frequency, which ever was higher, up to a maximum of 40GHz.

EQUIPMENT: UA352 Rev 01X3

FCC ID: F5302RF5501433

Section 8. Test Equipment List**Equipment List – Conducted Emissions - Anechoic Chamber**

CAL Cycle	Equipment	Manufacturer	Model No.	Asset/Serial No.	Last Cal.	Next Cal.
1 Year	LISN	EMCO	4825/2	FA001545	Oct. 09/01	Oct. 09/02
1 Year	LISN(peripheral)	Tegam	95300-50	FA000986	Oct. 22/01	Oct. 22/02
1 Year	LISN(peripheral)	Tegam	95300-50	FA000986	Oct. 22/01	Oct. 22/02
1 Year	Receiver	Rohde & Schwarz	ESH3	FA000208	Mar. 07/02	Mar. 07/03
1 Year	Spectrum Analyzer	Hewlett-Packard	8566B	FA001309	Nov. 27/01	Nov. 27/02
1 Year	Spectrum Analyzer Display	Hewlett-Packard	85662A	FA001309	Nov. 27/01	Nov. 27/02
1 Year	Quasi-Peak Adapter	Hewlett-Packard	85650A	FA000801	Nov. 27/01	Nov. 27/02
1 Year	Transient Limiter	Hewlett-Packard	1194 7A	FA000975	Oct. 19/01	Oct. 19/02

Equipment List – Prescan for Radiated Emissions - Anechoic Chamber

CAL Cycle	Equipment	Manufacturer	Model No.	Asset/Serial No.	Last Cal.	Next Cal.
1 Year	Spectrum Analyzer	Hewlett-Packard	8566B	FA001309	Nov. 27/01	Nov. 27/02
1 Year	Spectrum Analyzer Display	Hewlett-Packard	85662A	FA001309	Nov. 27/01	Nov. 27/02
1 Year	Spectrum Analyzer	Hewlett-Packard	8564E	FA001367	Mar. 06/02	Mar. 06/03
1 Year	Quasi-Peak Adapter	Hewlett-Packard	85650A	FA000801	Nov. 27/01	Nov. 27/02
	Bilog Antenna	Schaffner	CBL6612B	FA001503	NCR	NCR
1 Year	Horn Antenna #2	EMCO	3115	FA000825	Dec. 01/01	Dec. 01/02
NCR	0.1 – 1300 MHz Amplifier	Hewlett Packard	8447D	FA001748	NCR	NCR
1 Year	1.0 – 2.0 GHz Amplifier	JCA	12-400	FA001498	June. 04/02	June. 04/03

Equipment List - Radiated Emissions

CAL Cycle	Equipment	Manufacturer	Model No.	Asset/Serial No.	Last Cal.	Next Cal.
1 Year	Receiver	Rohde & Schwarz	ESVP	FA000871	Sept. 19/01	Sept. 19/02
1 Year	Spectrum Analyzer	Hewlett-Packard	8564E	FA001367	Mar. 06/02	Mar. 06/03
1 Year	Biconical (1) Antenna	EMCO	3109	FA000805	Aug. 22/01	Aug. 22/02
1 Year	Horn Antenna #2	EMCO	3115	FA000825	Dec. 01/01	Dec. 01/02
1 Year	Log Periodic Antenna #1	EMCO	LPA-25	FA000477	Aug. 28/01	Aug. 28/02
1 Year	1.0 – 2.0 GHz Amplifier	JCA	12-400	FA001498	June. 04/02	June. 04/03

Nemko Canada Inc.

FCC 47 CFR PART 15, SUBPART B: 1999

CLASS B CERTIFICATION

PROJECT NO.: 2W04794

ANNEX A

EQUIPMENT: UA352 Rev 01X3

FCC ID: F5302RF5501433

Annex A

Prescans For Engineering Evaluation Only

EQUIPMENT: UA352 Rev 01X3
FCC ID: F5302RF5501433

Prescan Data

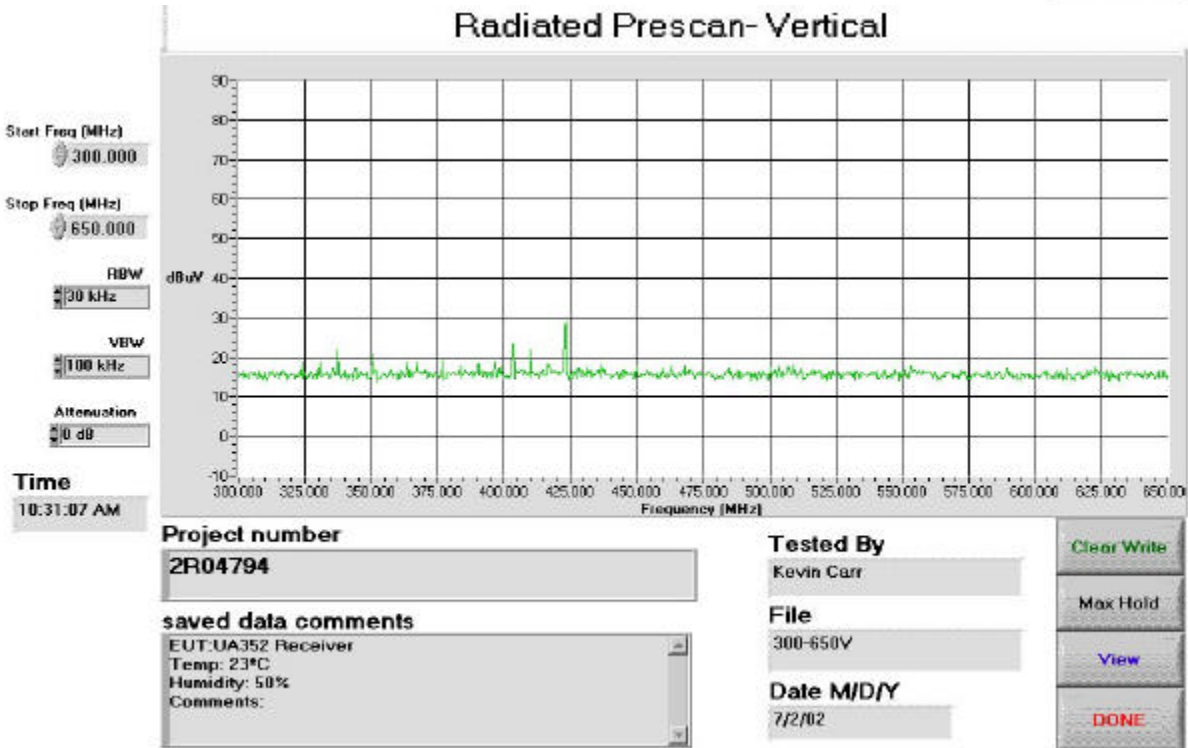
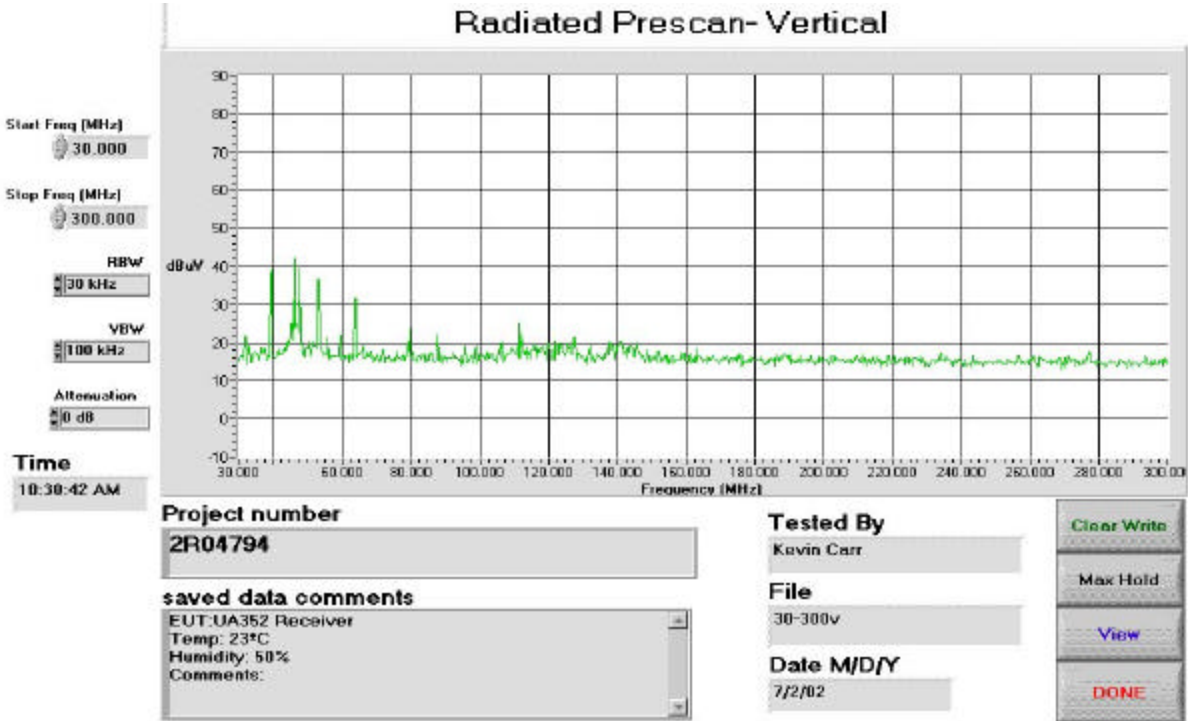

EQUIPMENT: UA352 Rev 01X3
FCC ID: F5302RF5501433

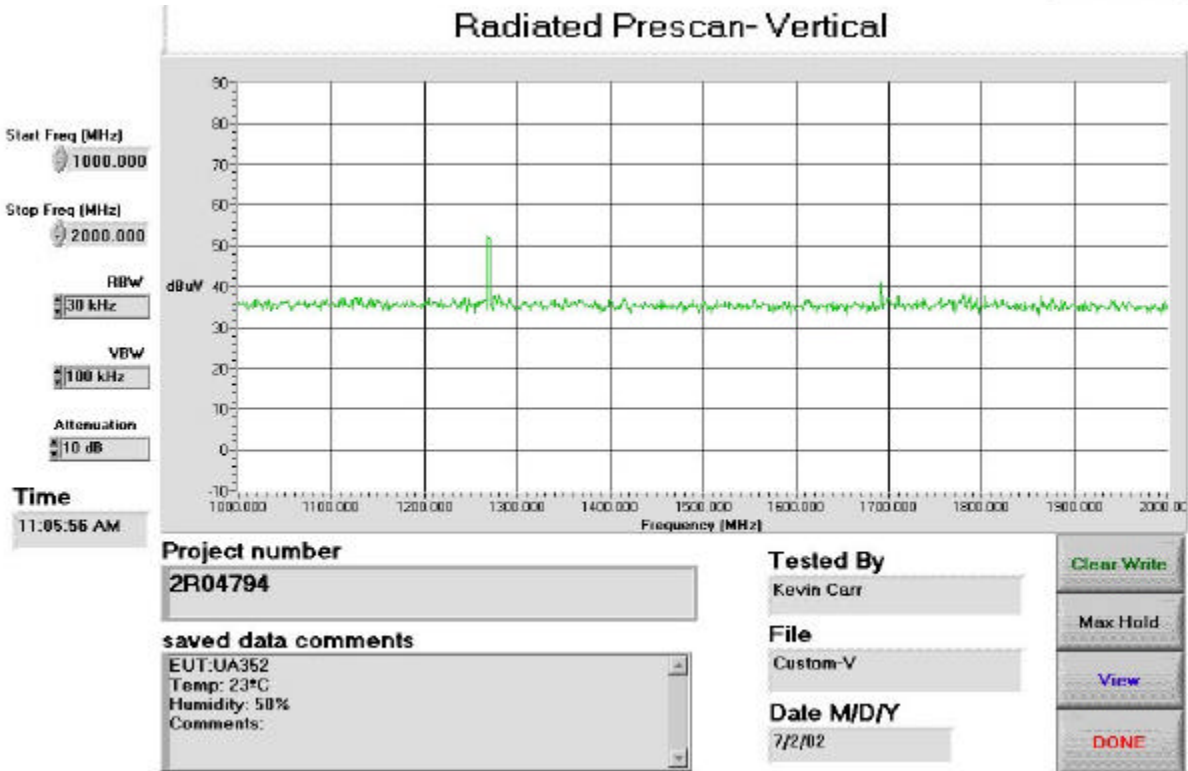
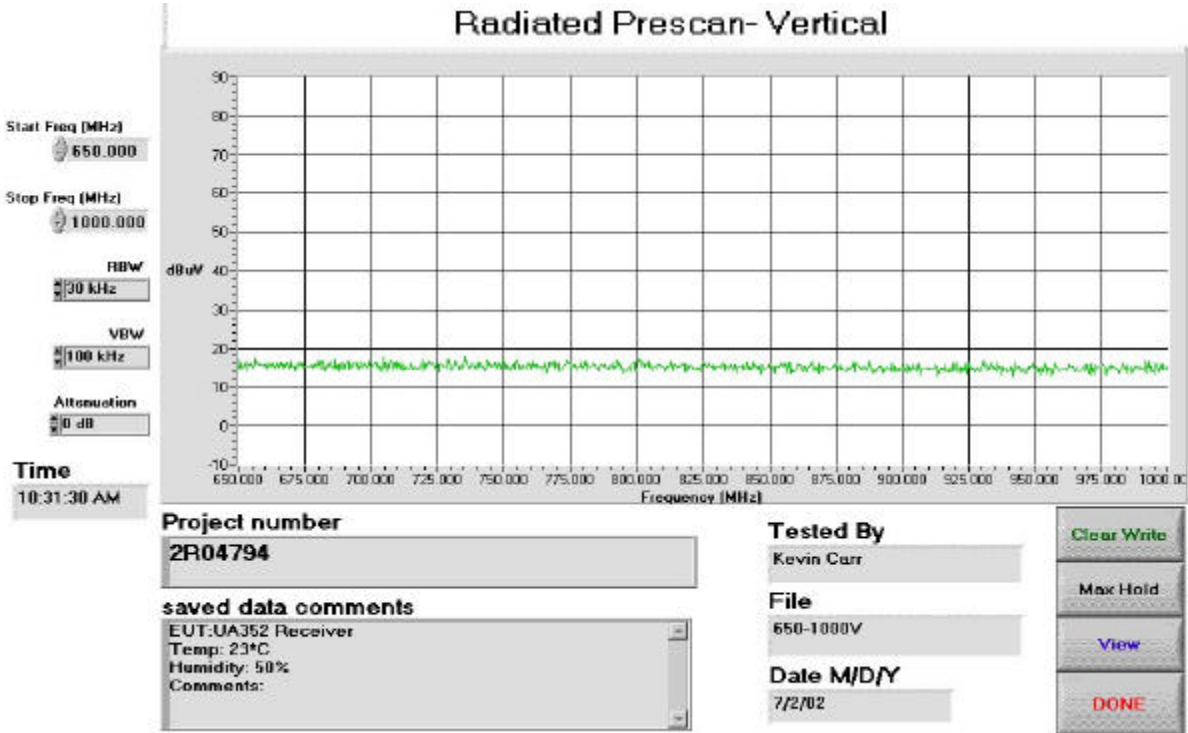

EQUIPMENT: UA352 Rev 01X3
FCC ID: F5302RF5501433

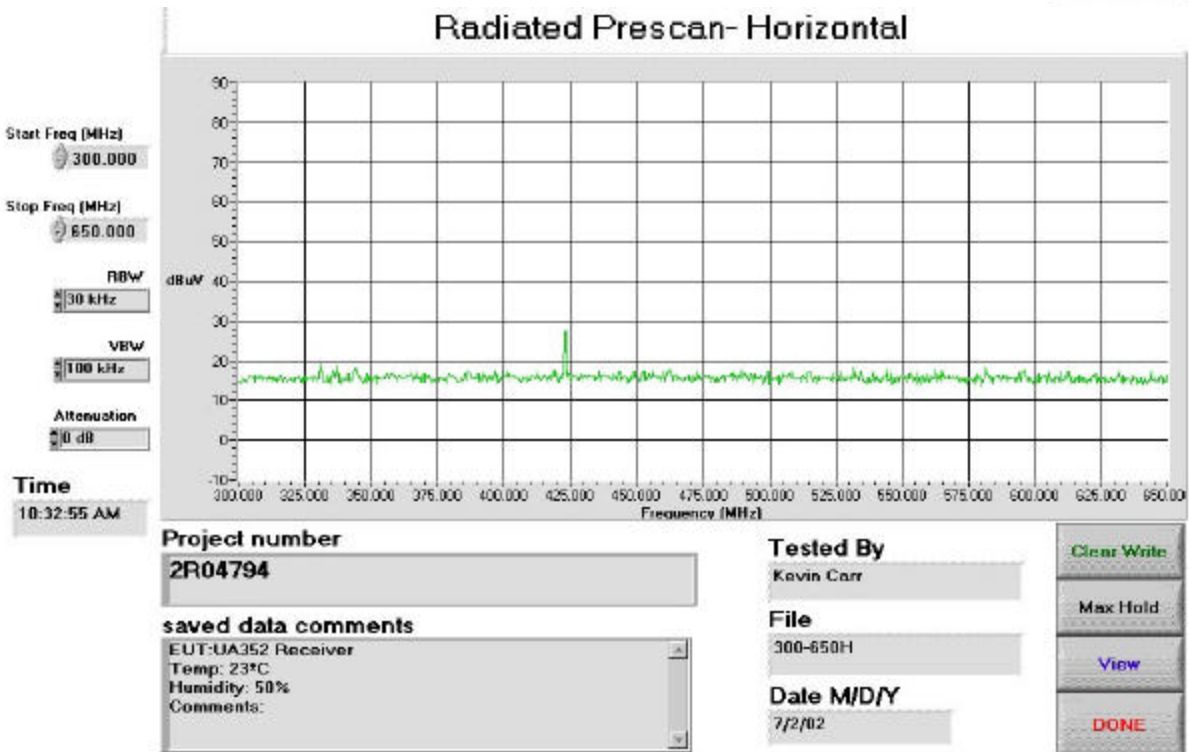
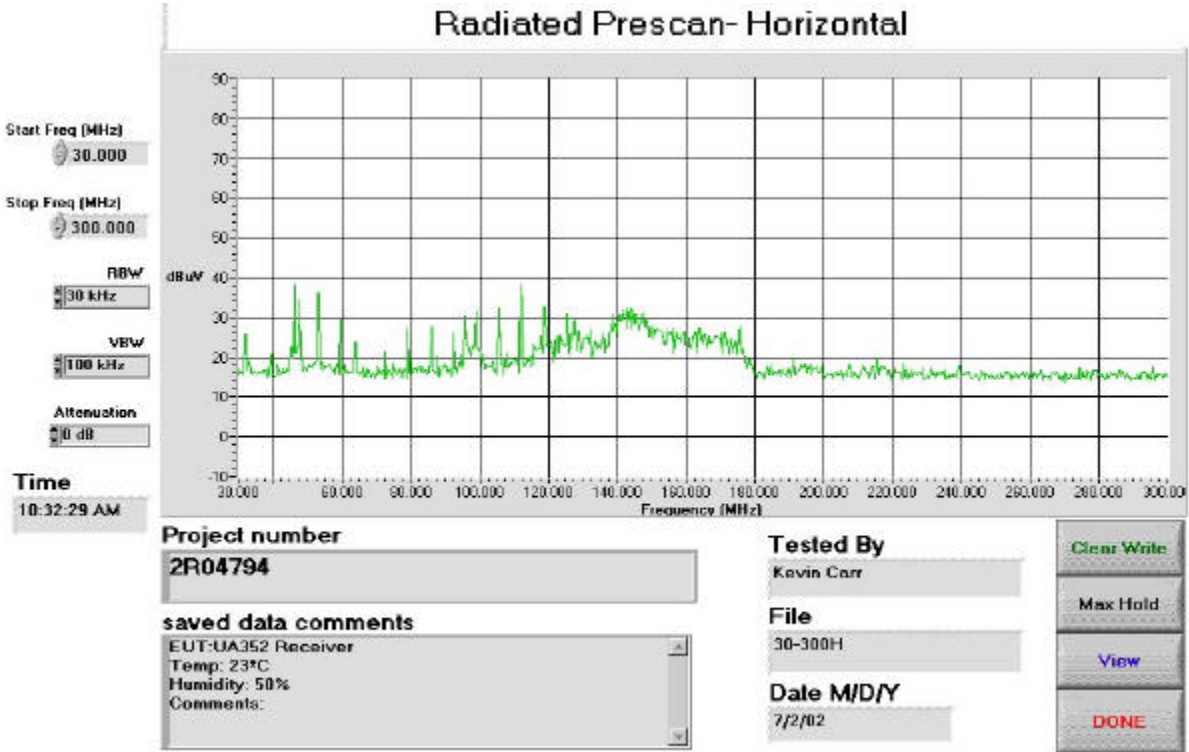

EQUIPMENT: UA352 Rev 01X3
FCC ID: F5302RF5501433

