



Compliance Testing, LLC

Previously Flom Test Lab

EMI, EMC, RF Testing Experts Since 1963

toll-free: (866) 311-3268

fax: (480) 926-3598

<http://www.ComplianceTesting.com>

info@ComplianceTesting.com

Test Report

Prepared for: Bird Technologies Group

Model: 614 Series/470 – 488 MHz

Description: Class B UHF Digital Signal Booster

FCC ID: EZZ61470A

To

FCC Part 90

Date of Issue: May 14, 2015

On the behalf of the applicant:

Bird Technologies Group
30303 Aurora Road
Solon, OH 44139

Attention of:

Amy Sanvido, RF Engineer
Ph: (440) 519-2179
E-Mail: asanvido@bird-technologies.com

Prepared By
Compliance Testing, LLC
1724 S. Nevada Way
Mesa, AZ 85204
(480) 926-3100 phone / (480) 926-3598 fax
www.compliancetesting.com
Project No: p1460008

Greg Corbin
Project Test Engineer

This report may not be reproduced, except in full, without written permission from Compliance Testing
All results contained herein relate only to the sample tested



Test Report Revision History

Revision	Date	Revised By	Reason for Revision
1.0	July 9, 2014	Greg Corbin	Original Document
2.0	October 31, 2014	Greg Corbin	Updated references on the Test Summary Table, Added Input plots for Occupied Bandwidth, Added section for Radiated Output Power
3.0	December 17, 2014	Greg Corbin	Added block diagram and model number of unit as tested to page 6. Added F1W emission designator to the table on page 7.
4.0	January 5, 2014	Greg Corbin	Removed emission designator F1W from the table on page 7
5.0	April 27, 2015	Greg Corbin	Added clarification to the narrowband filter description on page 6
6.0	May 12.2015	Greg Corbin	Revised ERP statement at bottom of page 13



Table of Contents

<u>Description</u>	<u>Page</u>
Standard Test Conditions and Engineering Practices	5
Test Result Summary	9
Out of Band Rejection	10
Conducted Output Power and Amplifier Gain	13
Radiated Output Power	Error! Bookmark not defined.
Conducted Spurious Emissions	14
Radiated Spurious Emissions	19
Emission Masks (Occupied Bandwidth)	20
Intermodulation	37
Noise Figure Test	41
Test Equipment Utilized	42



ILAC / A2LA

Compliance Testing, LLC, has been accredited in accordance with the recognized International Standard ISO/IEC 17025:2005. This accreditation demonstrates technical competence for a defined scope and the operation of a laboratory quality management system (refer joint ISO-ILAC-IAF Communiqué dated January 2009)

The tests results contained within this test report all fall within our scope of accreditation, unless noted below.

Please refer to <http://www.compliancetesting.com/labscope.html> for current scope of accreditation.

Testing Certificate Number: **2152.01**



FCC Site Reg. #349717

IC Site Reg. #2044A-2

Non-accredited tests contained in this report:

N/A



The Applicant has been cautioned as to the following:

15.21: Information to the User

The user’s manual or instruction manual for an intentional radiator shall caution the user that changes or modifications not expressly approved by the party responsible for compliance could void the user’s authority to operate the equipment.

15.27(a): Special Accessories

Equipment marketed to a consumer must be capable of complying with the necessary regulations in the configuration in which the equipment is marketed. Where special accessories, such as shielded cables and/or special connectors are required to enable an unintentional or intentional radiator to comply with the emission limits in this part, the equipment must be marketed with, i.e. shipped and sold with, those special accessories. However, in lieu of shipping or packaging the special accessories with the unintentional or intentional radiator, the responsible party may employ other methods of ensuring that the special accessories are provided to the consumer, without an additional charge.

Information detailing any alternative method used to supply the special accessories for a grant of equipment authorization or retained in the verification records, as appropriate. The party responsible for the equipment, as detailed in § 2.909 of this chapter, shall ensure that these special accessories are provided with the equipment. The instruction manual for such devices shall include appropriate instructions on the first page of text concerned with the installation of the device that these special accessories must be used with the device. It is the responsibility of the user to use the needed special accessories supplied with the equipment.

Test and Measurement Data

All tests and measurement data shown were performed in accordance with FCC Rules and Regulations Part 90.219, KDB 935210 D03 Booster, or FCC Part 2 where appropriate.

Standard Test Conditions and Engineering Practices

Except as noted herein, the following conditions and procedures were observed during the testing.

In accordance with ANSI/TIA 603C, and unless otherwise indicated in the specific measurement results, the ambient temperature of the actual EUT was maintained within the range of 10° to 40°C (50° to 104°F) unless the particular equipment requirements specify testing over a different temperature range. Also, unless otherwise indicated, the humidity levels were in the range of 10% to 90% relative humidity.

Environmental Conditions		
Temp (°C)	Humidity (%)	Pressure (mbar)
23.0 – 29.4	23.3 – 38.1	960.8 – 968.5

Measurement results, unless otherwise noted, are worst-case measurements.



EUT Description

Model Tested: 614-70A-A-HH-G1-B (High Power) and 614-70A-A-LL-G1-B (Low Power)

Description: Class B UHF Digital Signal Booster

Firmware: R21.D6

Software: N/A

Additional Information:

The EUT is a Class B industrial UHF digital signal booster operating from 470 – 488 MHz. The downlink operates from 470 – 485 MHz and the uplink operates from 473 – 488 MHz.

Each band has a low power and high power output, configurable in software but not available to the end user, the selection of either low or high power is a factory setting only.

All the test data was recorded in both the low power and high power modes of operation.

The downlink and uplink bands have wideband bandpass filters that cover the entire band.

Additional filtering is provided by quantity two (2x) 3 MHz cavity filters, at the inputs of the uplink and downlink paths, which are selected depending on the final installation requirements.

These cavity filters were not installed during the testing of the signal booster in order to test the entire band. The manufacturer has declared that the filter insertion loss is specified to be 2 dB maximum. Sample tests of the 4 filters that were available showed the insertion loss to be 1.5 – 2.1dB. Leaving these filters out provided the worst case test results for the required tests.

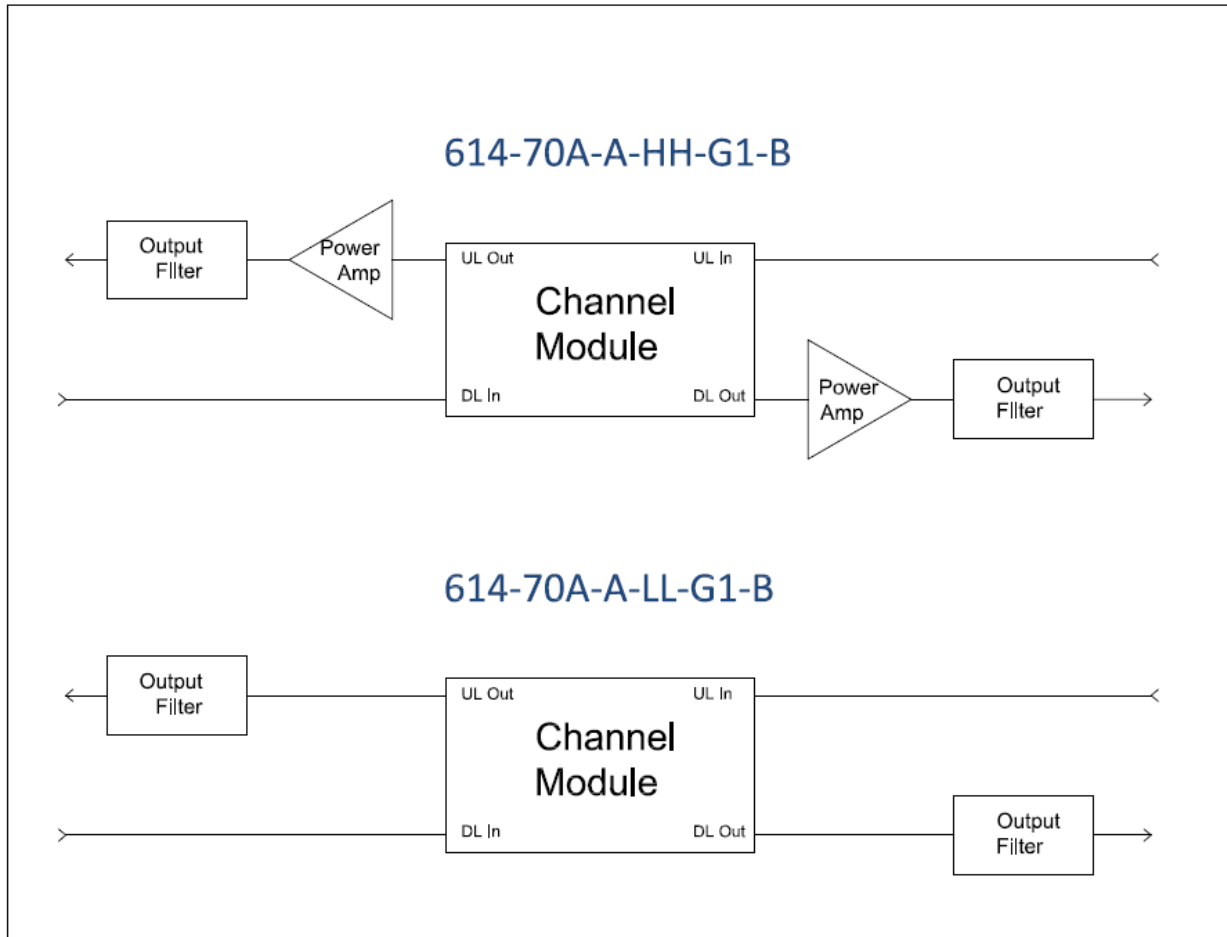



The signal booster uses the following frequency bands.
The emission designators the system is designed to accommodate are shown below.

	Frequency (MHz)	Emission Designators
Downlink	470 - 485	F3E, F3D, F1E
Uplink	473 - 488	F3E, F3D, F1E

EUT Operation during Tests

The manufacturer was present to operate the equipment during the testing of the signal booster. The manufacturer used a proprietary software program to interface with the EUT in order to change frequencies and set the power level. As mentioned in the additional information, the cavity filters were not installed. The output power was set to the maximum level available for all the tests.

AGC Threshold

Several tests reference the AGC Threshold level.
The AGC Threshold was measured as follows:

- Connect a signal generator to the input of the EUT.
- Connect a spectrum analyzer to the output of the EUT using appropriate attenuation.
- Use a CW signal.
- While monitoring the output of the EUT, increase the input level until the output stops increasing or drops a few 10ths of a dB.
- This is the AGC threshold level of the EUT.
- When the procedure calls out to set the RF Input to just below the AGC Threshold, The AGC Threshold is measured using the procedure listed above, and then the RF Input is backed off 0.2 dB below this threshold level.



Accessories: None

Cables:

Qty	Description	Length (M)	Shielding Y/N	Shielded Hood Y/N	Termination
1	AC Power	2	N	N	N/A

Modifications: None



Test Result Summary

Specification	Test Name	Pass, Fail, N/A	Comments
KDB 935210-D03	Authorized Frequency Band	Pass	
2.1046	Output Power (Conducted)	Pass	
90.219(e)(1)	Radiated Output Power	Pass	
90.219(e)(4)(i)(ii)(iii) 90.210 2.1049	Occupied Bandwidth (Emission Masks)	Pass	
90.219(e)(3) 2.1051	Spurious Emissions (Transmitter Conducted)	Pass	
KDB 935210-D03	Intermodulation	Pass	
90.219(e)(2)	Noise Figure	Pass	
90.213	Frequency Stability (Temperature Variation)	N/A	The EUT does not perform frequency translation
90.213	Frequency Stability (Voltage Variation)	N/A	The EUT does not perform frequency translation



Out of Band Rejection

Name of Test: Out of Band Rejection

Test Equipment Utilized: i00405, i00424

Engineer: Greg Corbin

Test Date: 6/20/2014

Test Procedure

The EUT was connected to a spectrum analyzer through a 30 dB power attenuator. A signal generator was utilized to produce a swept CW signal with the RF input level set to 3 dB below the AGC Threshold level. The Uplink and Downlink filter response and the -20 dB bandwidth were measured. The marker table function of the spectrum analyzer was used to show the peak amplitude in the passband and the -20 dB bandwidth of the pass band filter.

RBW = 100 KHz

Video BW = 3x RBW

Test Setup





Out of Band Rejection Test Results Downlink_470 - 485 MHz_ Low Power mode

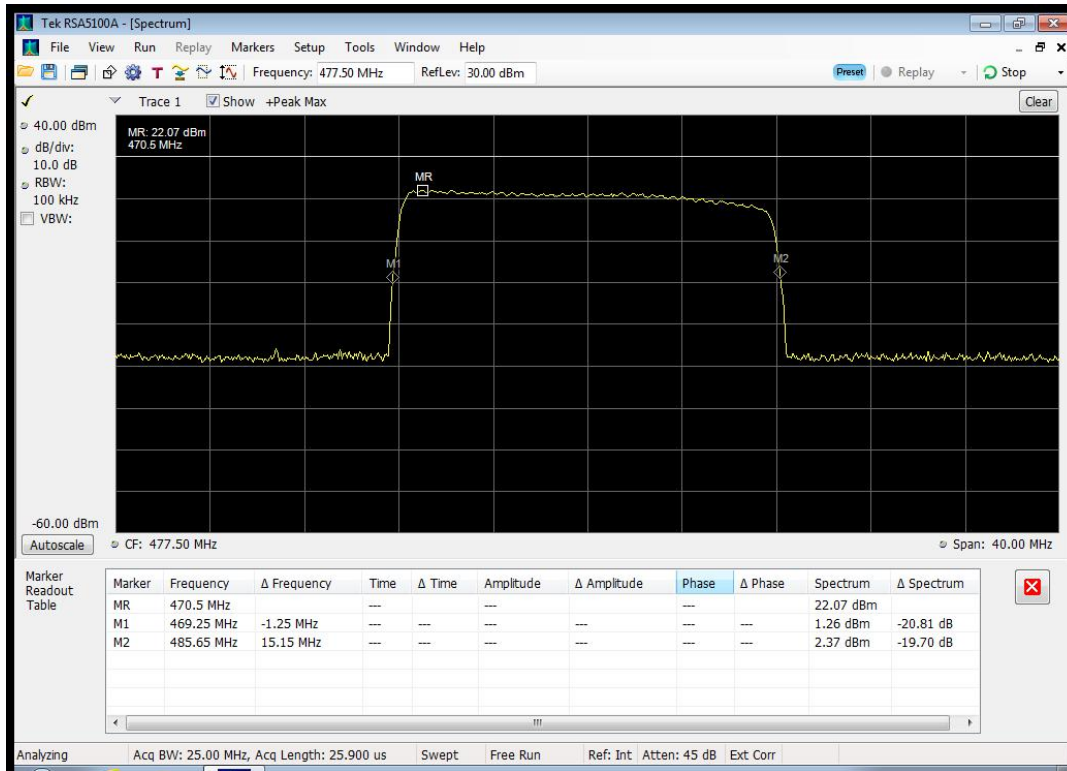

Downlink_470 - 485 MHz_ High Power mode

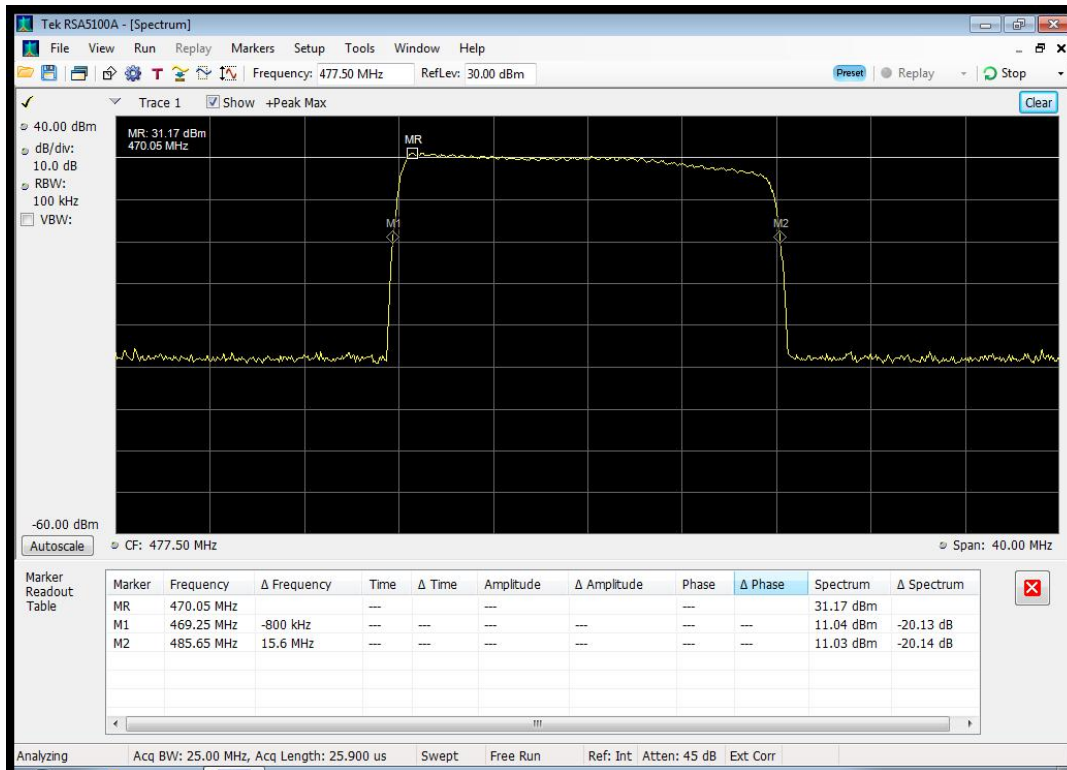



Uplink_473 - 488 MHz_Low Power mode

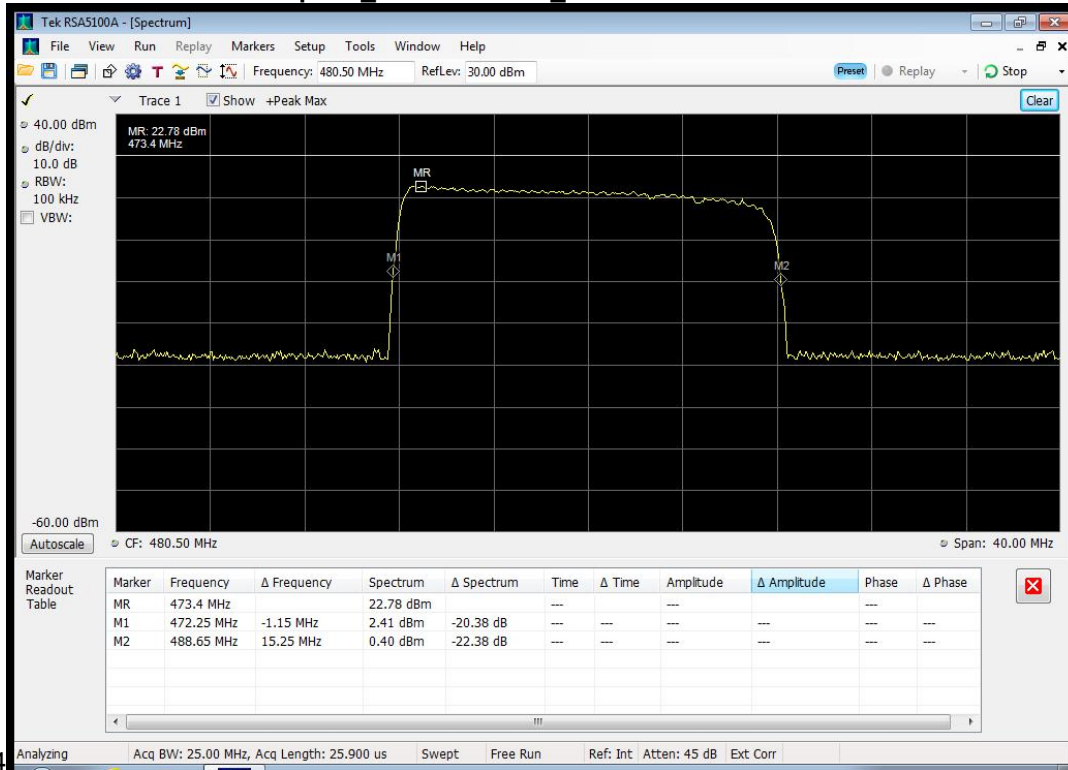

Uplink_473 - 488 MHz_High Power mode





Conducted Output Power and Amplifier Gain

Name of Test: Conducted Output Power and Amplifier Gain
Test Equipment Utilized: i00405, i00424

Engineer: Greg Corbin
Test Date: 6/20/2014

Measurement Procedure

The Equipment Under Test (EUT) was connected to a spectrum analyzer through a 30 dB Power attenuator. All cable and attenuator losses were input into the spectrum analyzer as a reference level offset to ensure accurate readings were obtained.

A CW signal was utilized, set to the frequency of the peak amplitude measured in the Out of Band Rejection test. The RF input signal level was set to 0.2 dB below the AGC Threshold.

RBW = 100 kHz

Video BW = 3x RBW

The Input and Output power levels were recorded and the gain was calculated using the following formula:

$$\text{Gain (dB)} = \text{Output Power (dBm)} - \text{Input Power (dBm)}$$

Test Setup

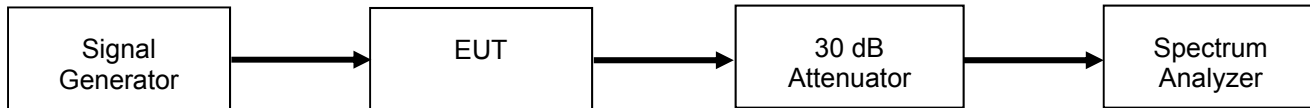

Downlink Output Power and Gain

Mode	Tuned Frequency (MHz)	Input Power (dBm)	Output Power (dBm)	Gain (dB)
Low Power	470.5	-57.6	25.1	82.7
High Power	470.5	-61.2	35.1	96.3

Uplink Output Power and Gain

Mode	Tuned Frequency (MHz)	Input Power (dBm)	Output Power (dBm)	Gain (dB)
Low Power	473.5	-67.8	25.7	93.5
High Power	473.5	-65.1	35.1	100.2

Radiated Output Power

Radiated Power (ERP) is dependent on the cable loss and antennas used when installed.

The maximum power output from the booster is limited to +37 dBm composite power by the GUI provided for to final end user.

The user's manual contains the following statement limiting the Radiated Output Power to 5 watts ERP at the time of installation.

Caution: The ERP from the booster system must not exceed +37dBm (5 Watts) in order to maintain compliant with FCC regulations



Conducted Spurious Emissions

Name of Test: Conducted Spurious Emissions
Test Equipment Utilized: i00405, i00424

Engineer: Greg Corbin
Test Date: 6/19/2014

Test Procedure

The Equipment Under Test (EUT) was connected to a spectrum analyzer through a 30 dB Power attenuator. All cable and attenuator losses were input into the spectrum analyzer as a combination of reference level offset and correction factor as needed to ensure accurate readings were obtained.

A CW signal was utilized, set to the center frequency of the passband.

The RF input signal level was set to 0.2 dB below the AGC Threshold.

The RBW was set to 100 kHz for measurements below 1 GHz and 1 MHz for measurements above 1 GHz.

The VBW was set to 3 times the RBW.

The frequency range from 30 MHz to the 10th harmonic of the passband frequency was observed and plotted.

The following formula was used for calculating the limits.

$$\text{Conducted Spurious Emissions Limit} = P1 - (43 + 10\text{Log}(P2)) = -13 \text{ dBm}$$

P1 = power in dBm

P2 = power in Watts

Test Setup

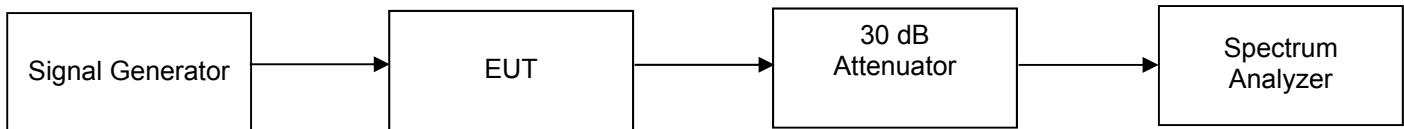

Downlink 470 - 485 MHz_ Conducted Spurious Emissions Summary Table

Mode	Tuned Frequency (MHz)	Spurious Frequency (MHz)	Measured Spurious Level (dBm)	Specification Limit (dBm)	Result
Low Power	477.5	4755	-16.0	-13	Pass
High Power	477.5	74.86	-25.8	-13	Pass

Uplink 473 - 488 MHz_ Conducted Spurious Emissions Summary Table

Mode	Tuned Frequency (MHz)	Spurious Frequency (MHz)	Measured Spurious Level (dBm)	Specification Limit (dBm)	Result
Low Power	480.5	44.55	-23.5	-13	Pass
High Power	480.5	961.2	-23.3	-13	Pass



Conducted Spurious Emissions Test Plots

Downlink 470 – 485 MHz _ Low Power_30 MHz – 1 GHz

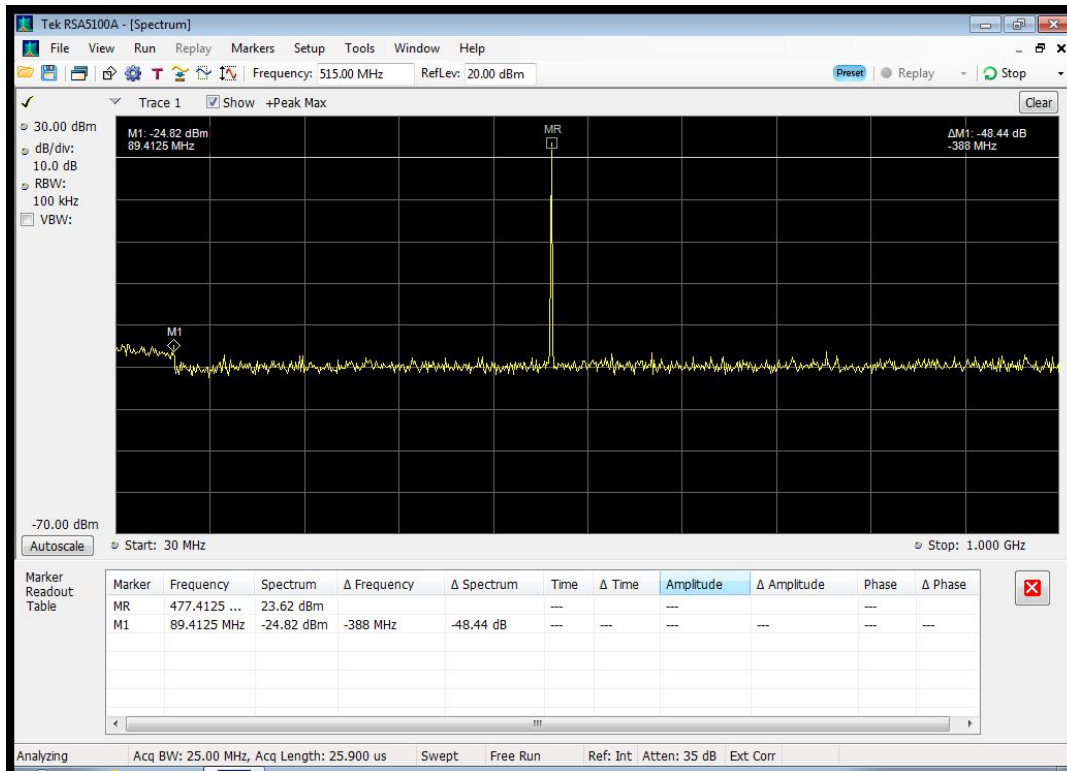

Downlink 470 – 485 MHz _ Low Power_1 – 5 GHz

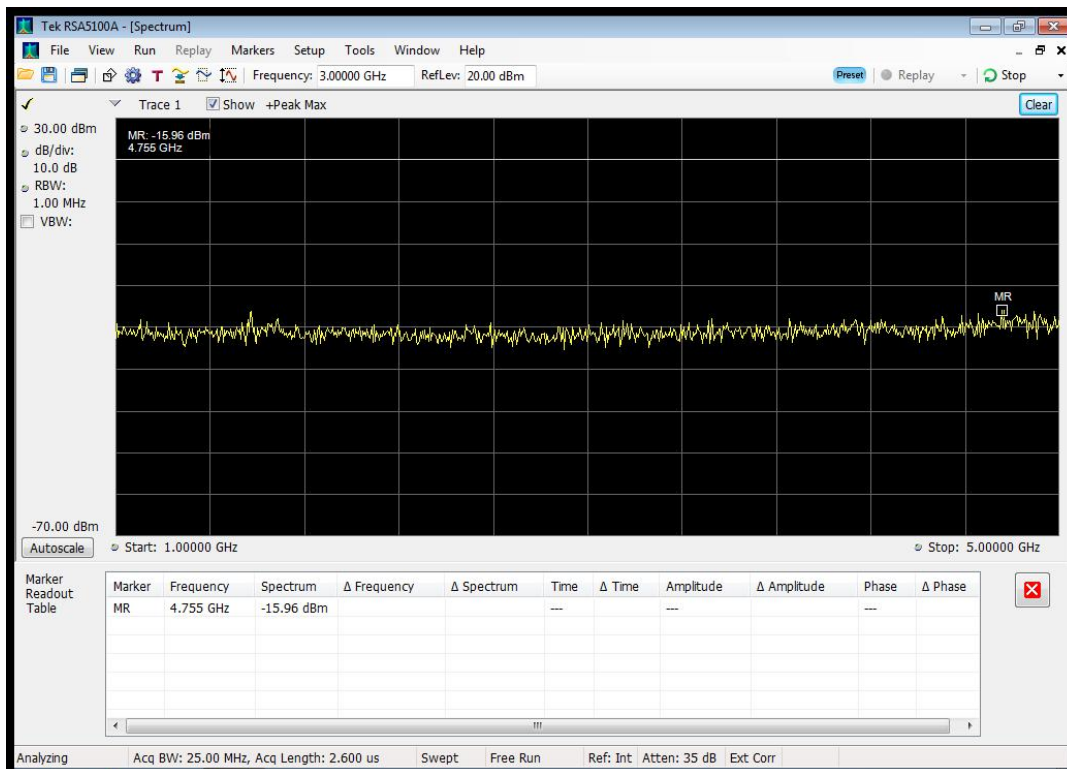



Downlink 470 – 485 MHz _ High Power_30 MHz – 1 GHz

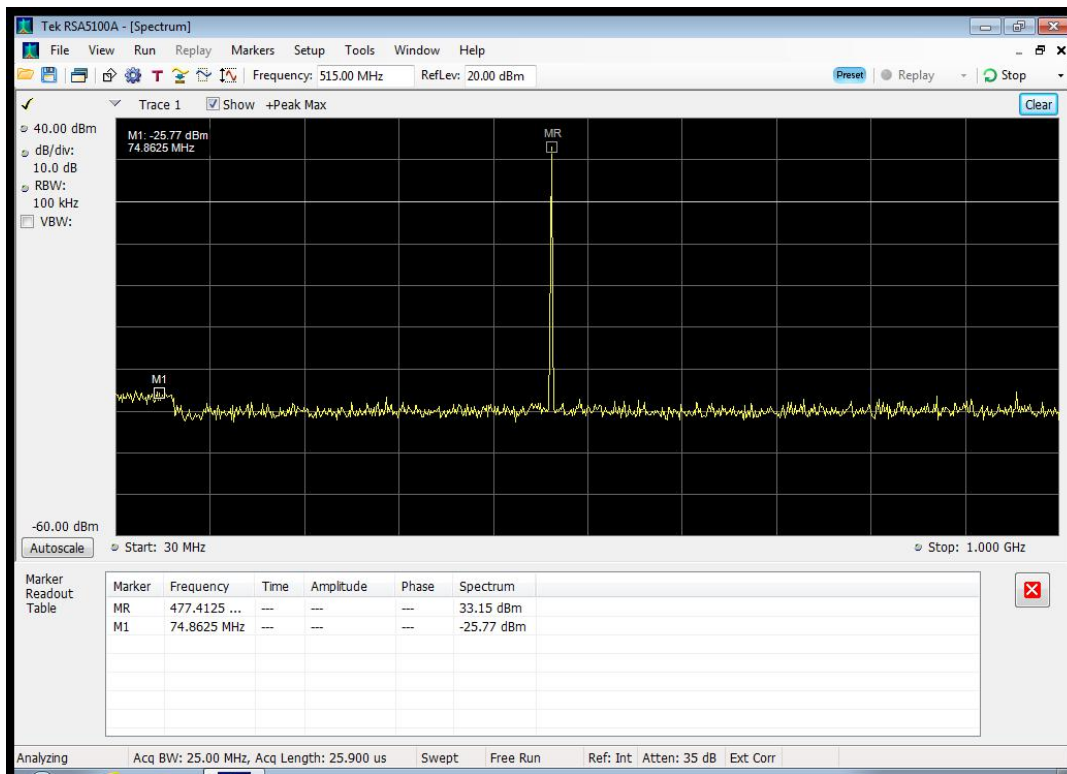

Downlink 470 – 485 MHz _ High Power_1 – 5 GHz

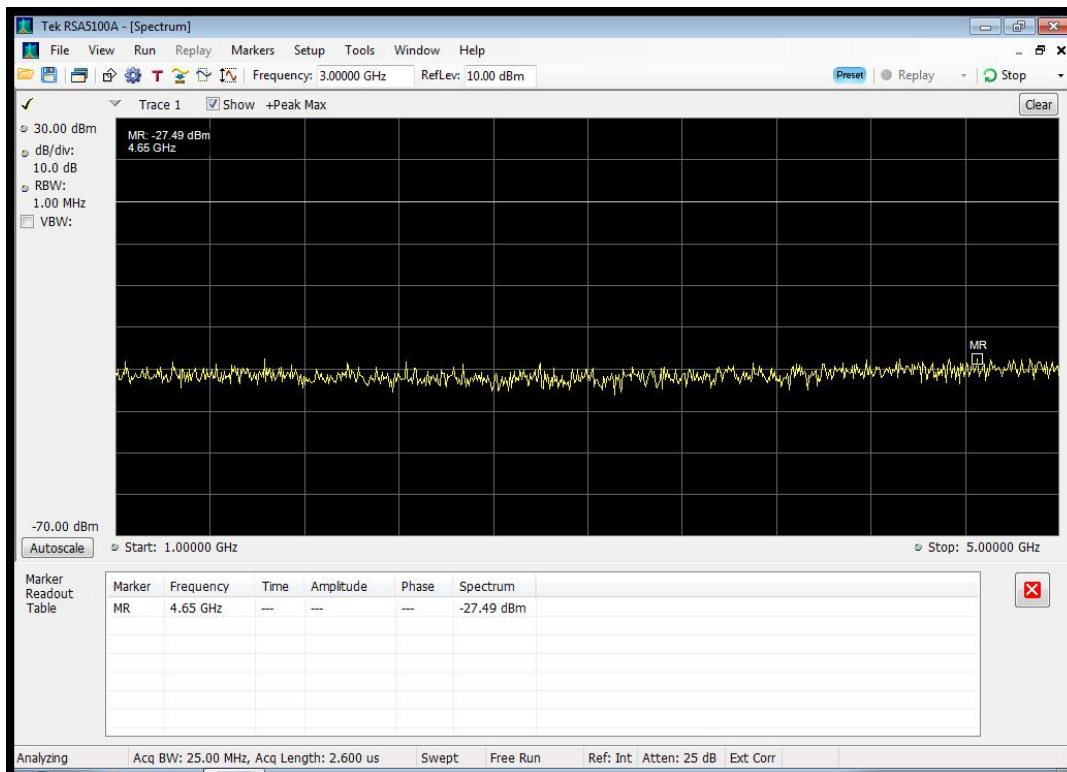



Uplink 473 – 488 MHz _ Low Power_30 MHz – 1 GHz

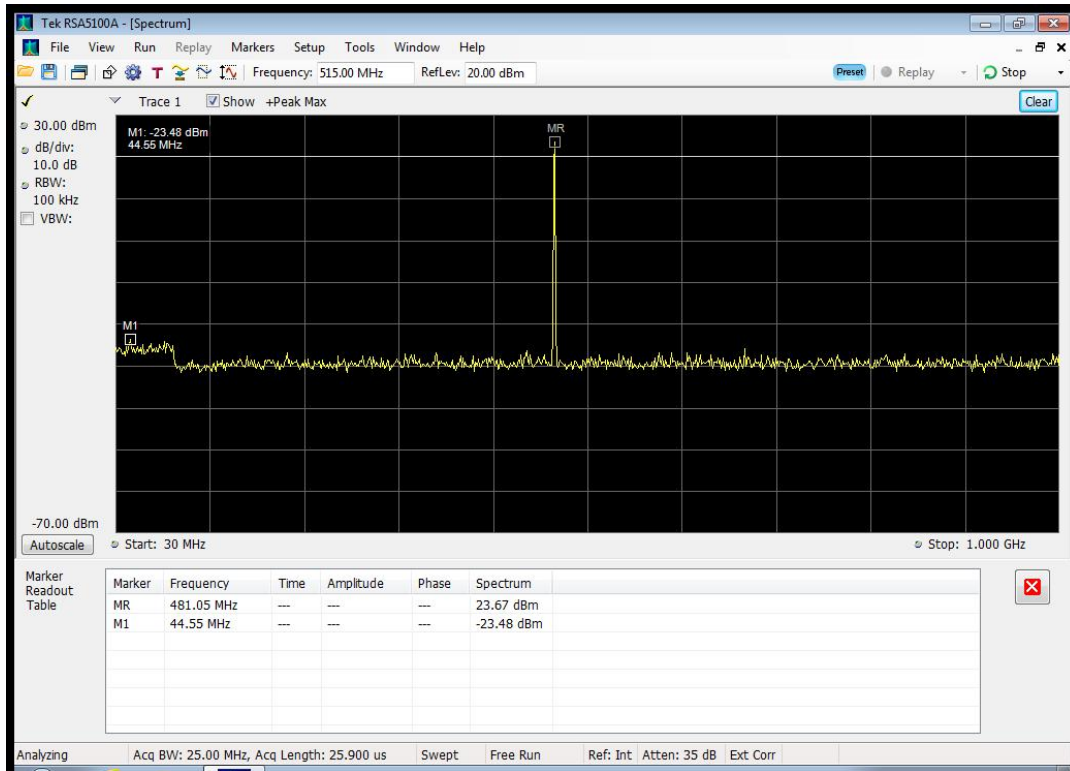

Uplink 473 – 488 MHz _ Low Power_1 – 5 GHz

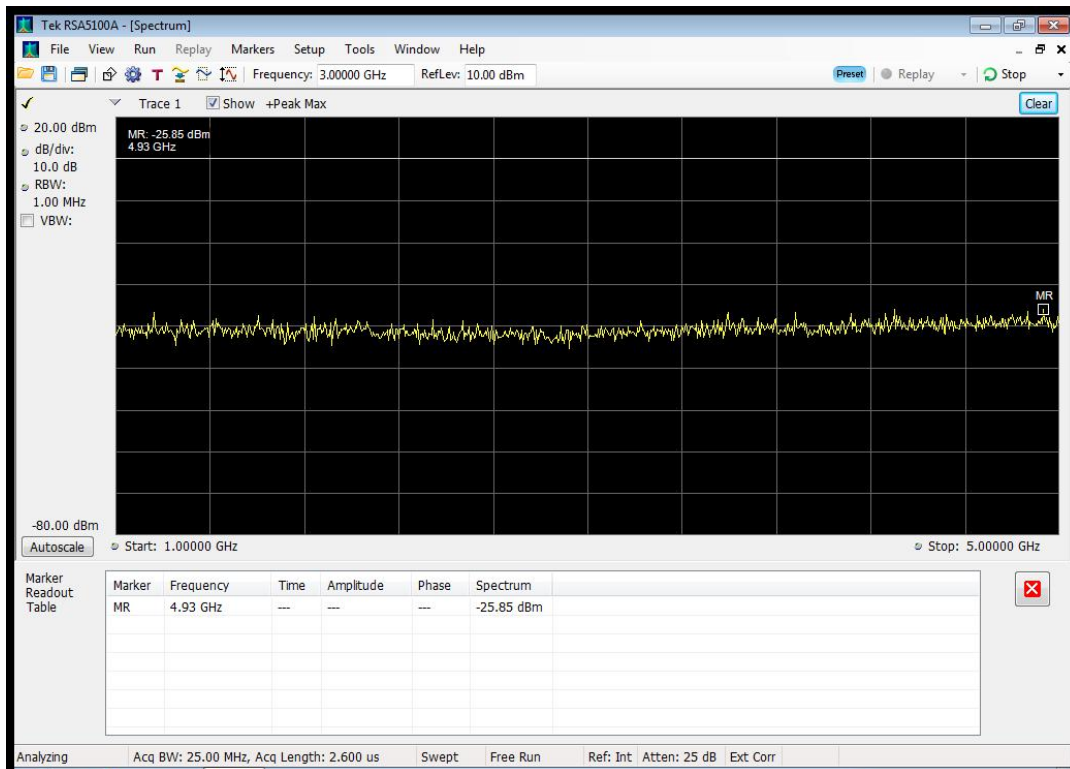



Uplink 473 – 488 MHz _ High Power_30 MHz – 1 GHz

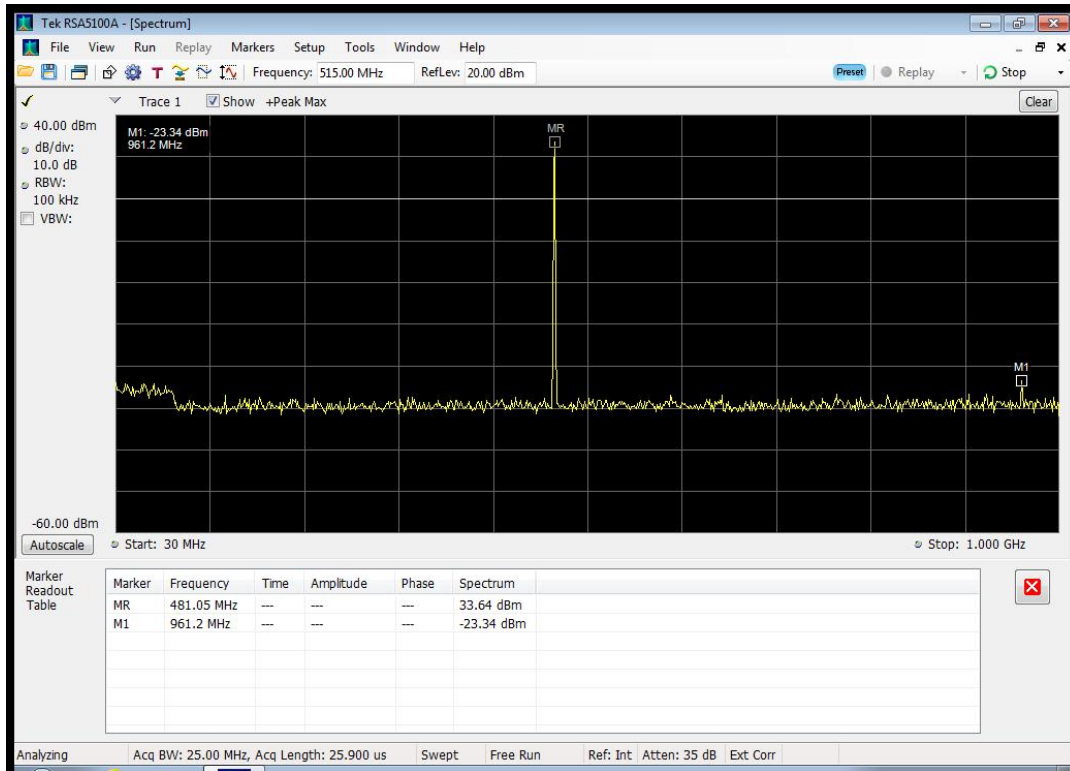

Uplink 473 – 488 MHz _ High Power_1 – 5 GHz

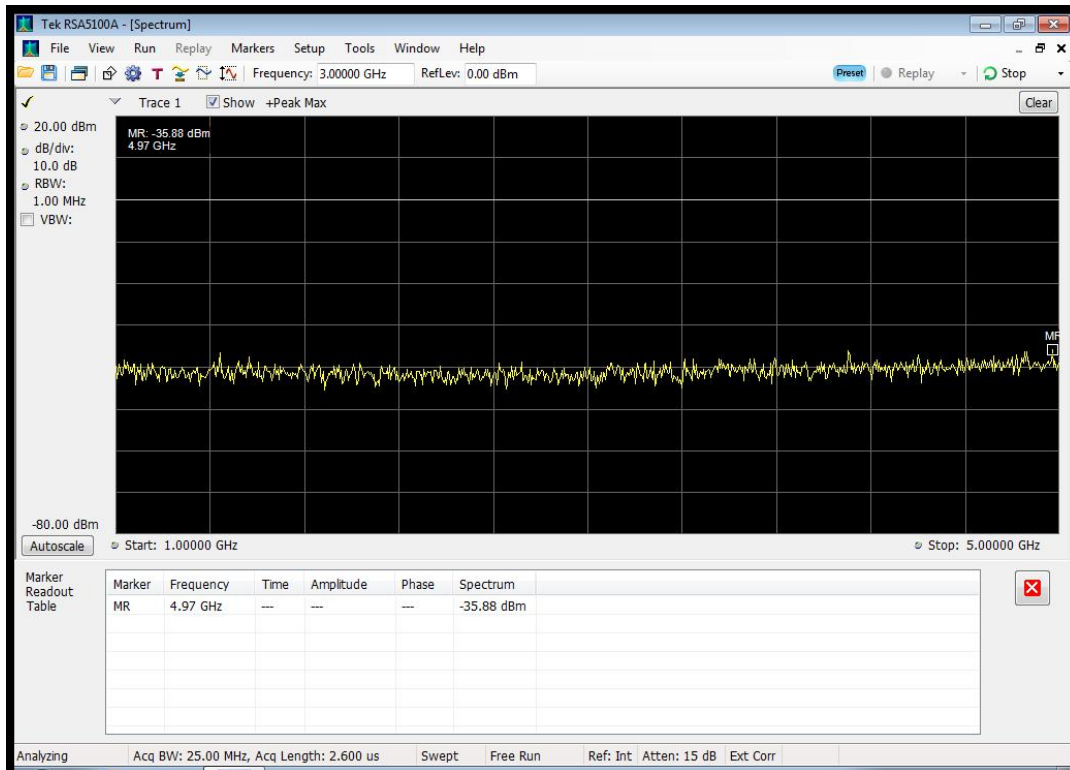



Radiated Spurious Emissions

Name of Test:

Radiated Spurious Emissions

Engineer: Greg Corbin

Test Equipment Utilized:

i00103, i00134, i00349, i00379,
i00405, i00428

Test Date: 6/20/2014

Test Procedure

The EUT was tested in an semi-anechoic chamber with the turntable set 3m from the receiving antenna. A spectrum analyzer was used to verify that the EUT met the requirements for Radiated Emissions. The EUT was tested by rotating it 360 degrees with the antenna in both the vertical and horizontal orientation while raised from 1 to 4 meters to ensure that the signal levels were maximized. All cable and antenna correction factors were input into the spectrum analyzer ensuring an accurate measurement in ERP/EIRP with the resultant power in dBm. A signal generator was used to provide a CW signal. The EUT output was terminated into a 50 Ohm non-radiating load.

The RBW was set to 100 kHz for measurements below 1 GHz and 1 MHz for measurements above 1 GHz. The VBW was set to 3 times the RBW.

The following formula was used for calculating the limits:

$$\text{Radiated Spurious Emissions Limit} = P1 - (43 + 10\text{Log}(P2)) = -13\text{dBm}$$

P1 = power in dBm

P2 = power in Watts

Test Setup

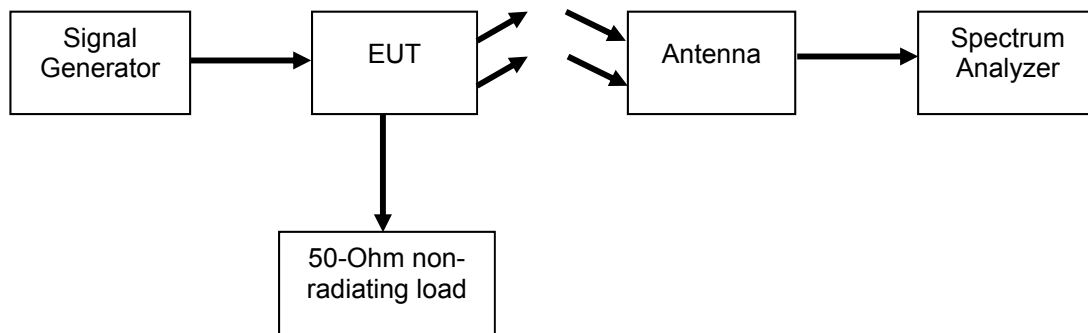

Test Results

Tuned Frequency (MHz)	Measured Frequency (MHz)	Measured Level (dBm)	Limit (dBm)	Result
480.5	961.0	-67.4	-13	Pass
480.5	1441.5	-59.8	-13	Pass
480.5	1922	-56.5	-13	Pass
480.5	2402.5	-51.7	-13	Pass

No other emissions were detected. All emissions were greater than -13 dBm.



Emission Masks (Occupied Bandwidth)

Name of Test: Emission Masks (Occupied Bandwidth) **Engineer:** Greg Corbin
Test Equipment Utilized i00405, i00424 **Test Date:** 6/20/2014

Measurement Procedure

The EUT was connected directly to a spectrum analyzer to verify that the EUT meets the required emissions mask. A reference level plot is provided to verify that the peak power was established prior to testing the mask. The EUT is a booster amplifier that does not contain a transmitter; representative emission designators used in the industry were used for the emission masks and are listed in Table 1. Emission Masks were measured in both the low power and high power modes of operation.

Emission Designator	Emission Mask	Type of Modulation	Occupied Bandwidth (kHz)	Channel Spacing (kHz)	Audio Frequency (kHz)	Deviation (kHz)	RBW (Hz)
16K0F3E	B	FM	16.0	25	2.5	5.0	300
11K3F3E	D	FM	11.3	12.5	1.0	2.5	100
4K00F1E	E	FM	4	6.25	1.0	1.0	100

Test Setup

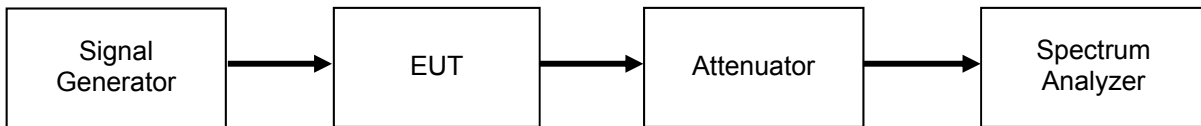



Emission Mask Plots

DownLink_Low Power_ 470 - 485 MHz
Tuned Frequency = 477.5 MHz

Reference Plot for Mask

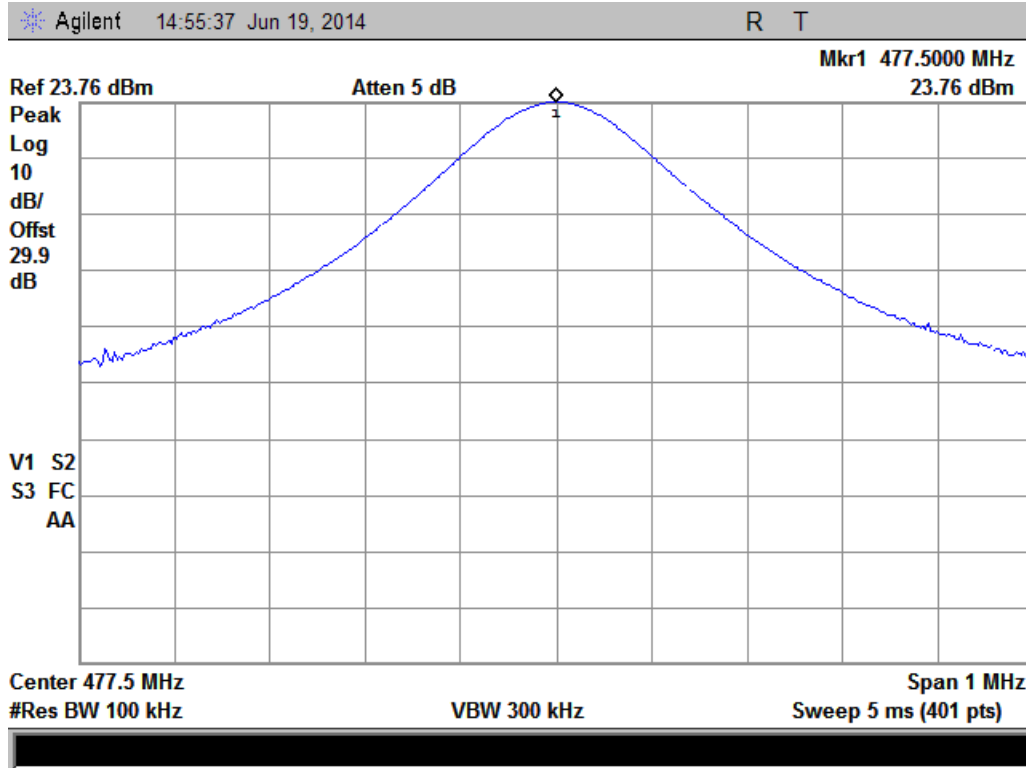



Input Signal for Mask B

Agilent 13:18:12 Oct 31, 2014 R T

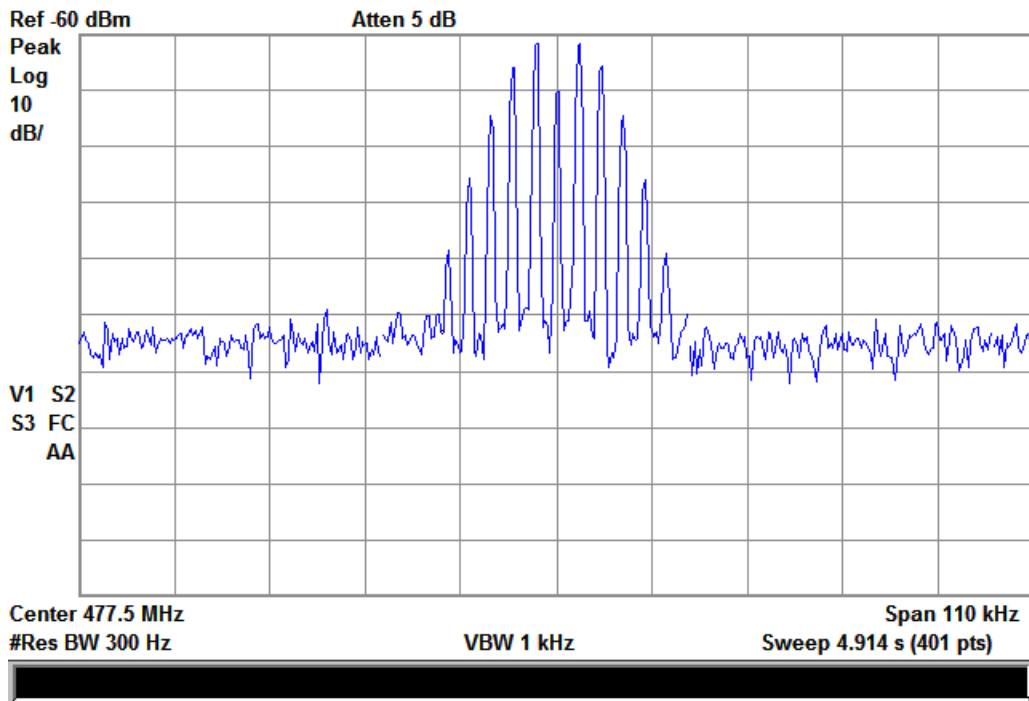

Mask B_Output Signal

Agilent 15:08:14 Jun 19, 2014 R T

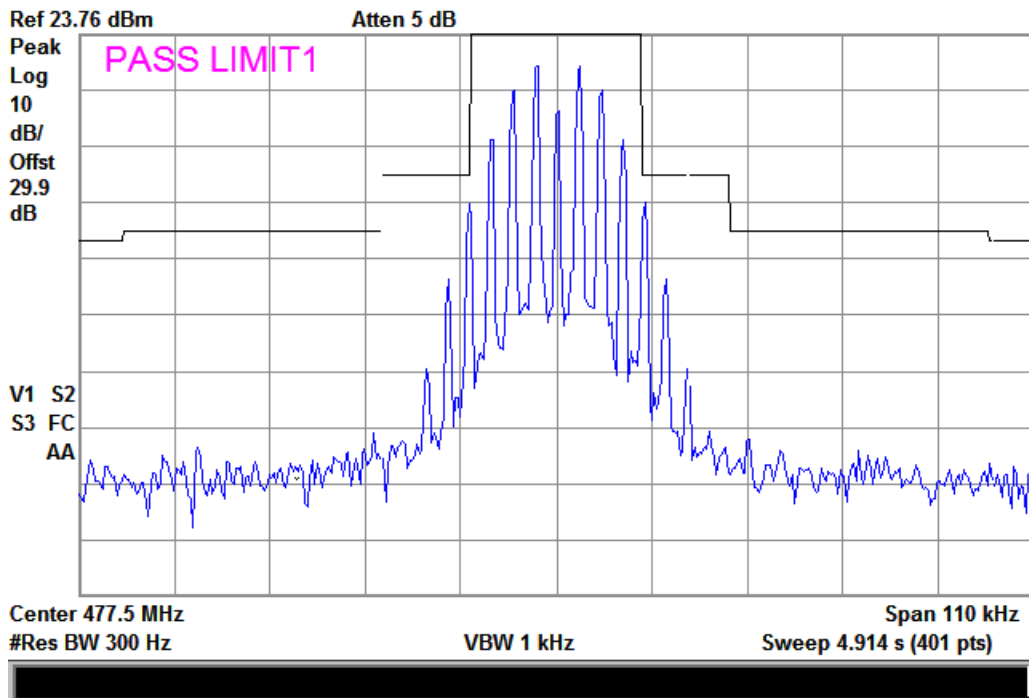



Input Signal for Mask D

Agilent 13:23:59 Oct 31, 2014 R T

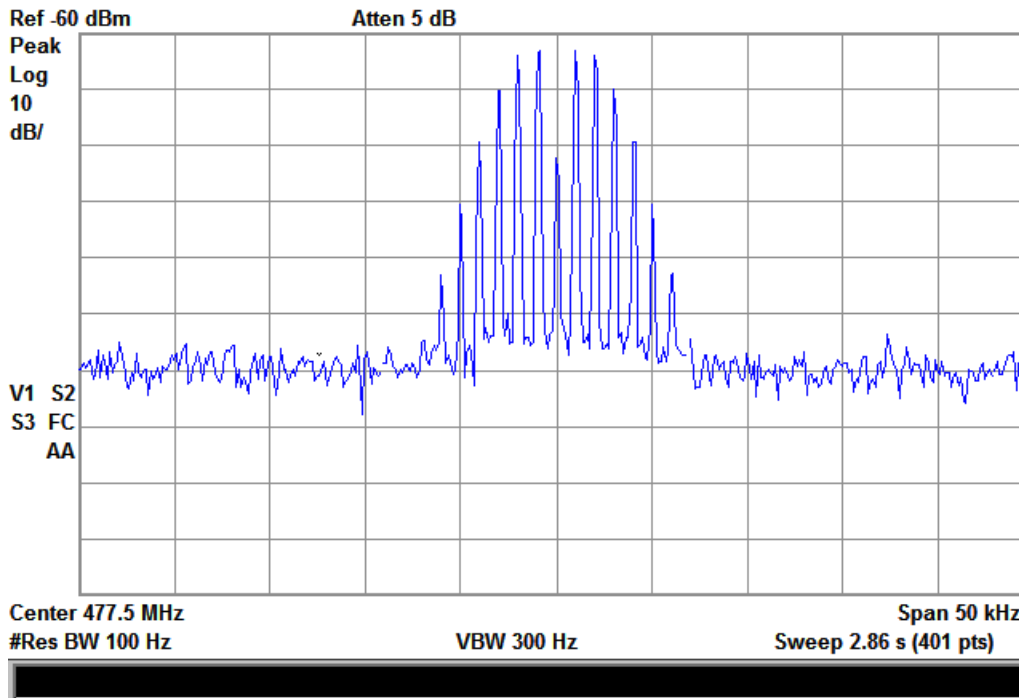

Mask D_Output Signal

Agilent 15:20:05 Jun 19, 2014 R T

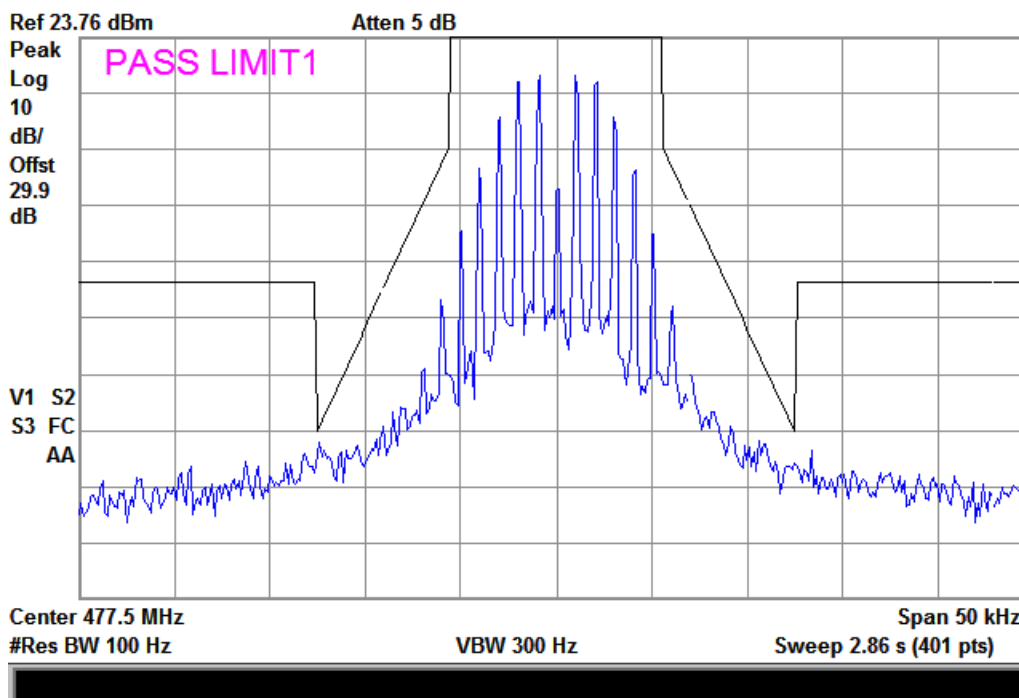



Input Signal for Mask E

Agilent 13:25:13 Oct 31, 2014 R T

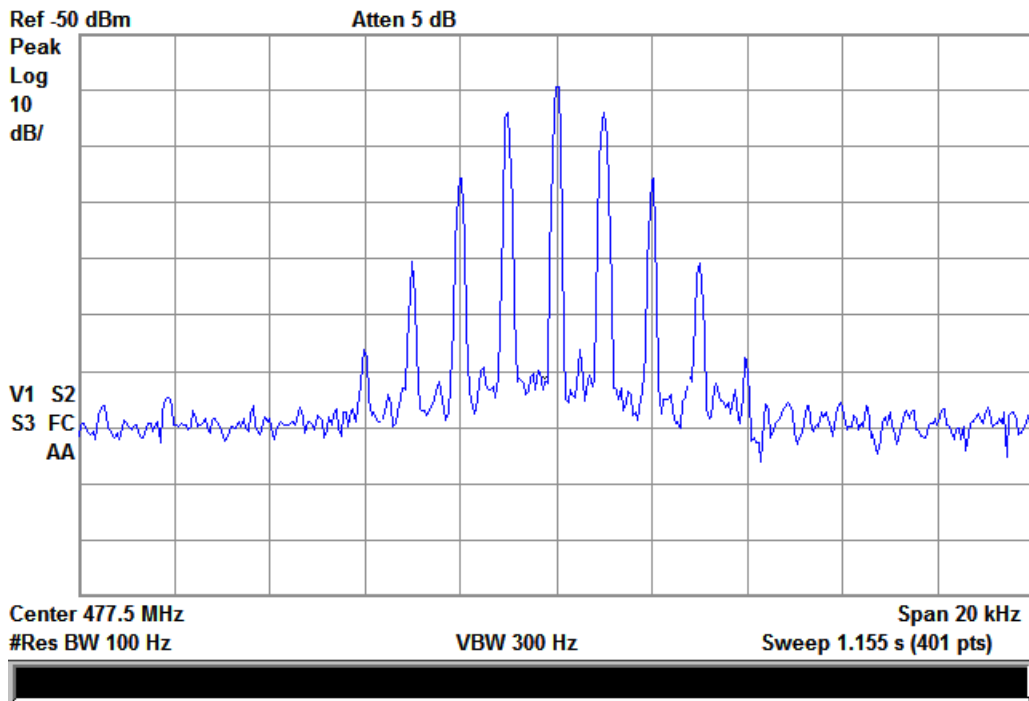

Mask E_Output Signal

Agilent 15:29:48 Jun 19, 2014 R T

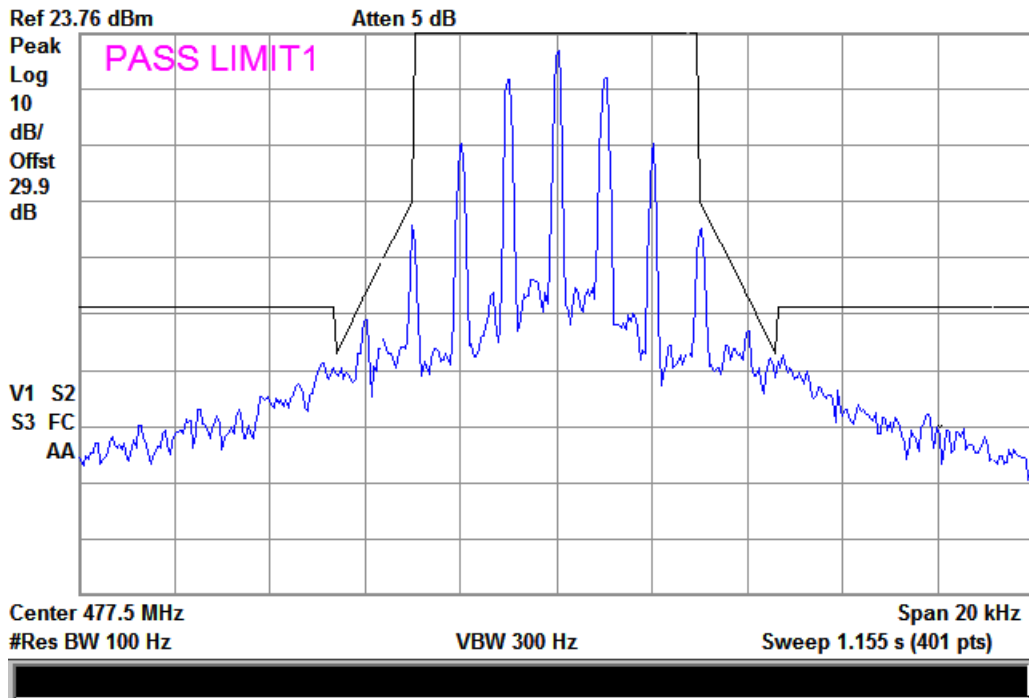



Uplink_Low Power_473 - 488 MHz
Tuned Frequency = 480.5 MHz

Reference Plot for Mask

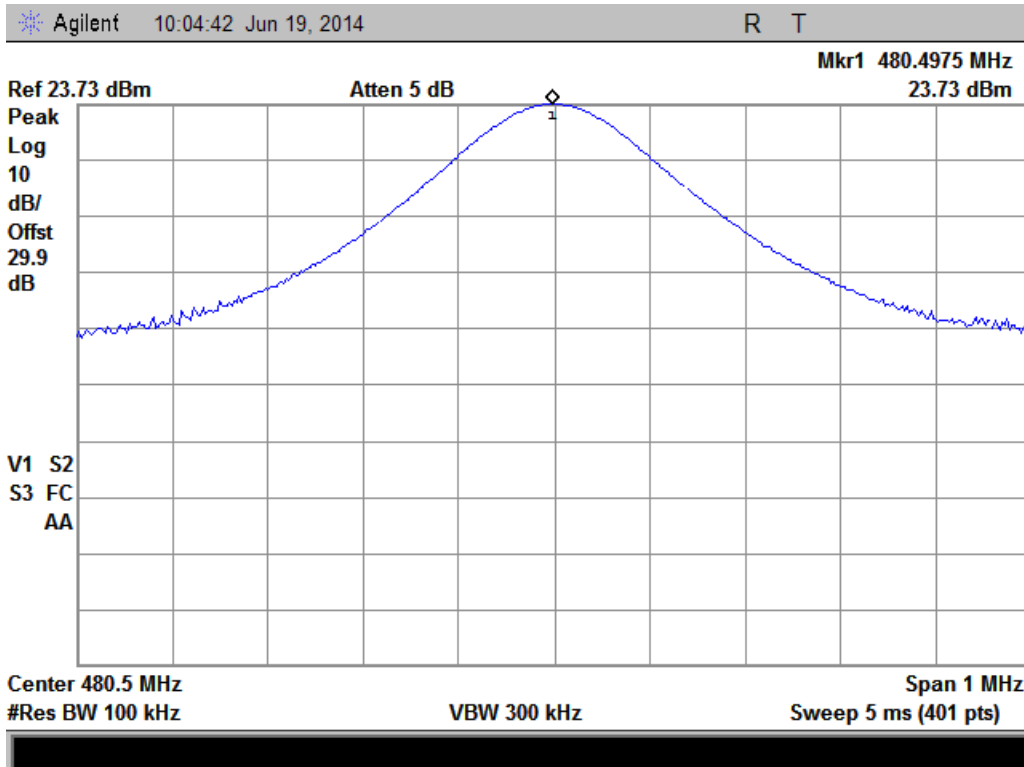



Input Signal for Mask B

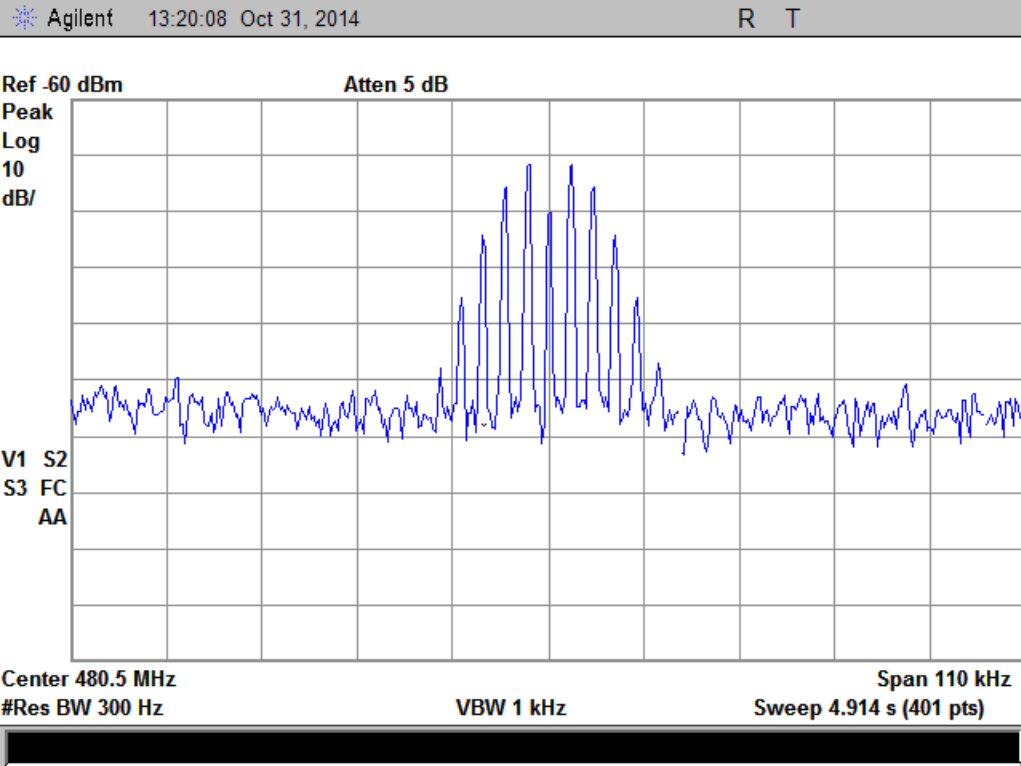

Mask B_Output Signal

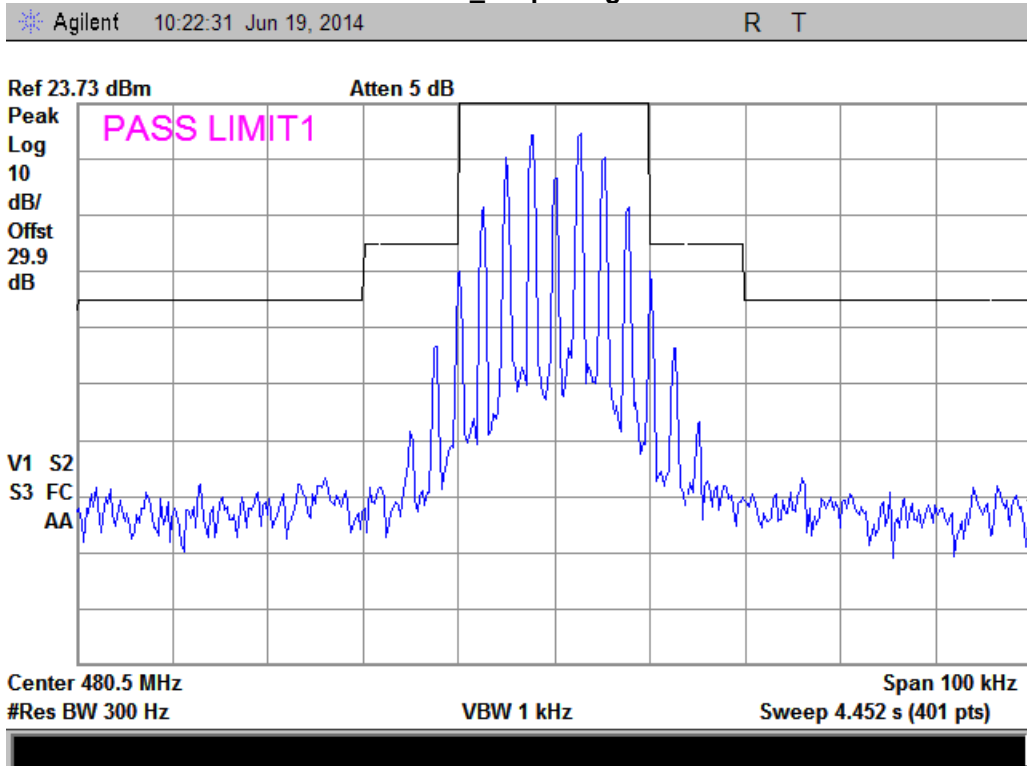



Input Signal for Mask D

Agilent 13:22:16 Oct 31, 2014 R T

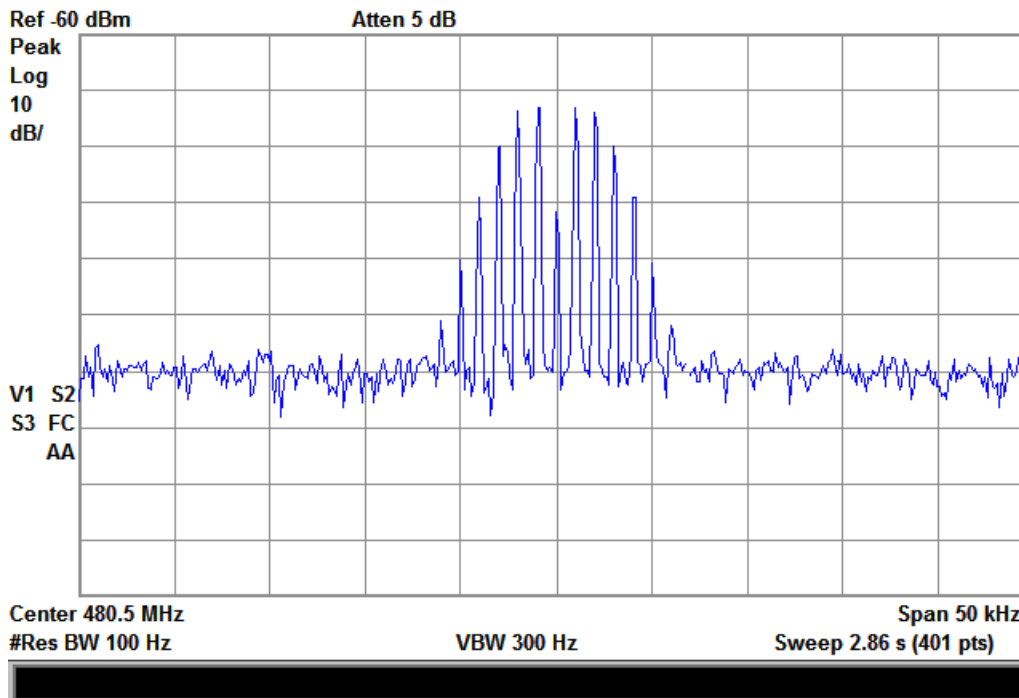

Mask D_Output Signal

Agilent 11:00:47 Jun 19, 2014 R T

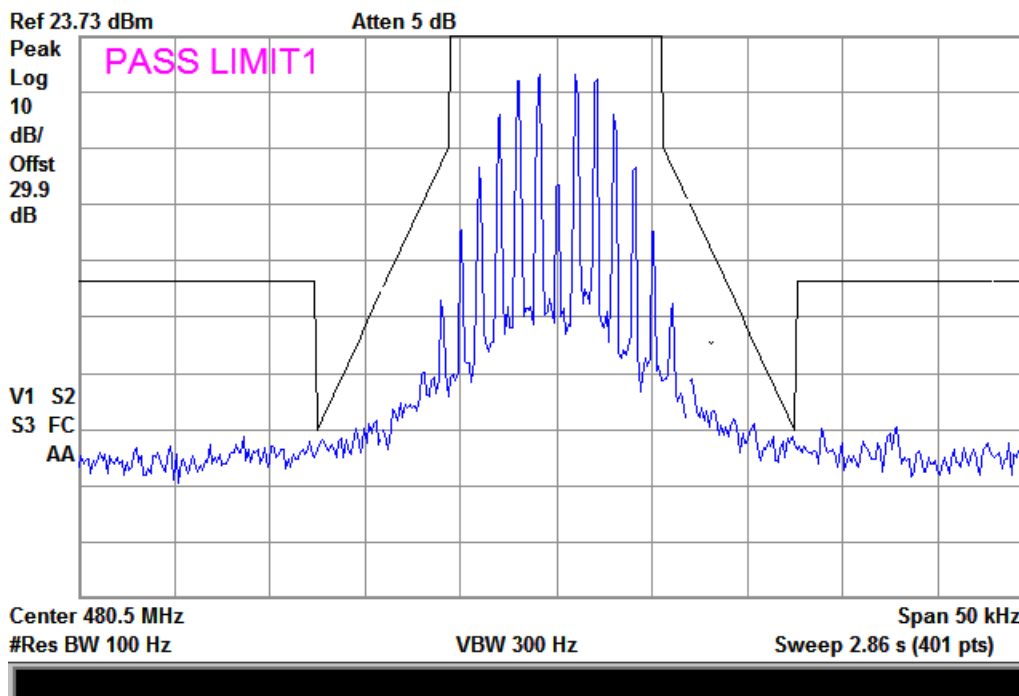



Mask E Input Signal

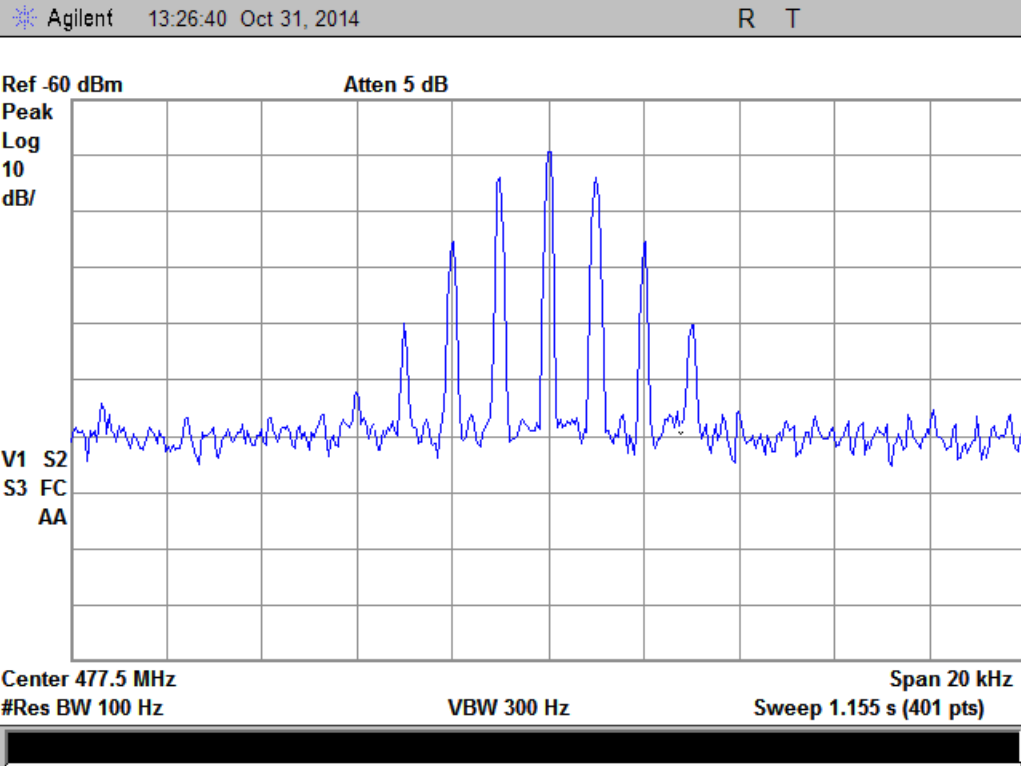

Mask E Output Signal

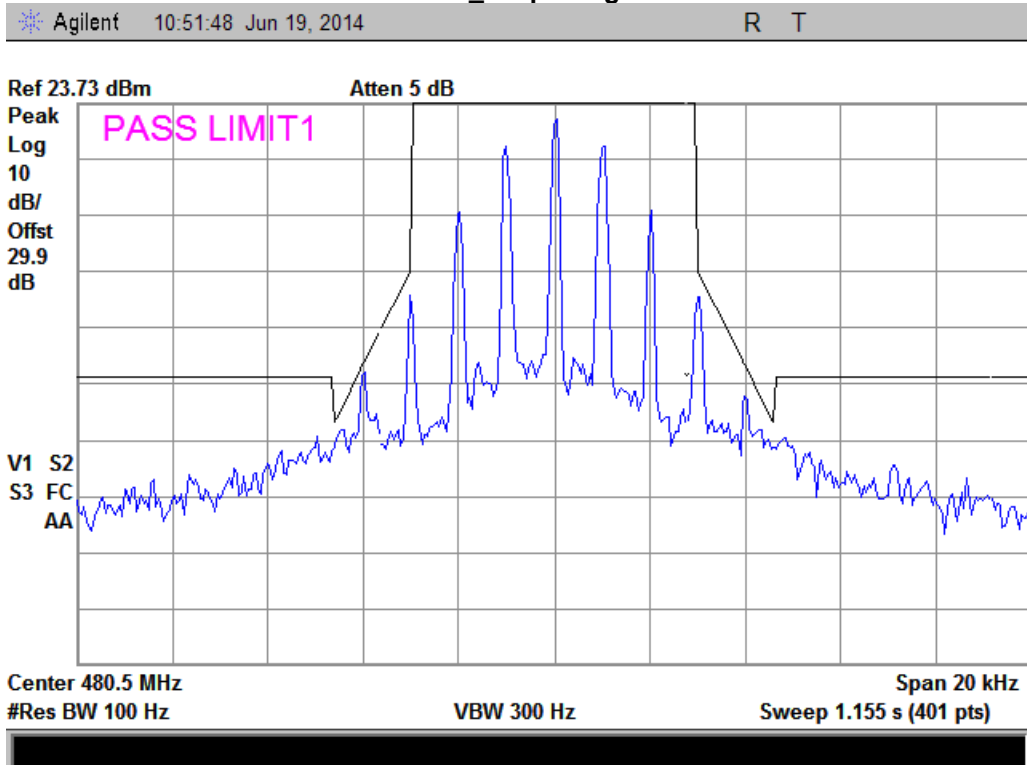



DownLink_High Power_470 - 485 MHz
Tuned Frequency = 477.5 MHz

Reference Plot for Mask

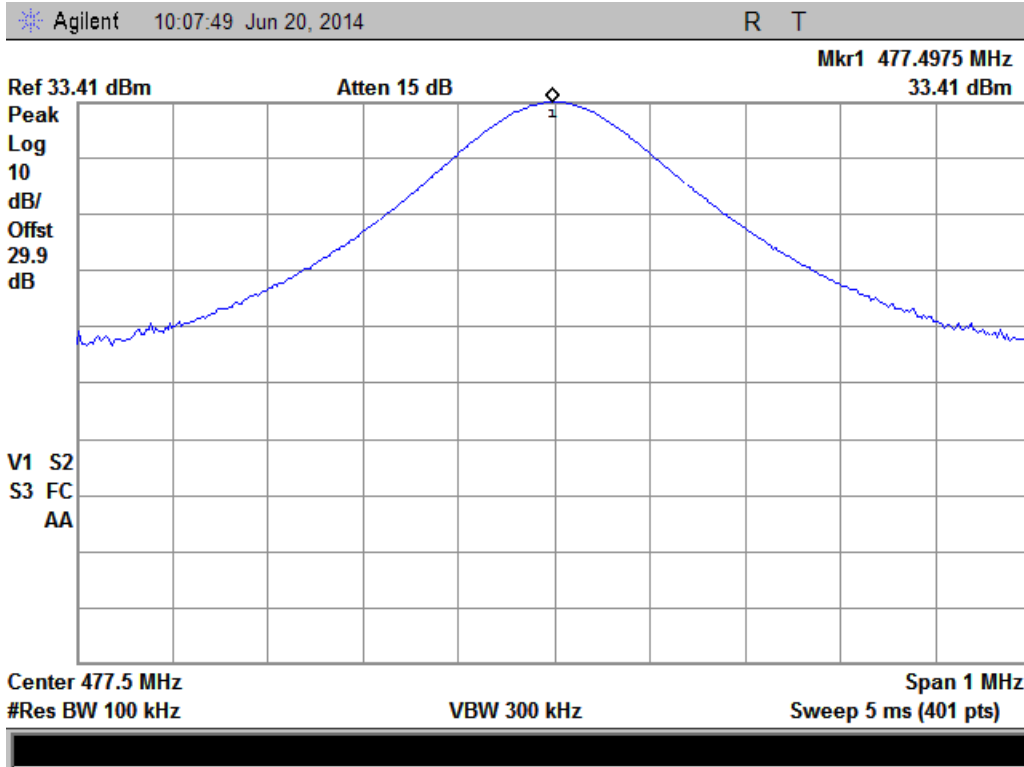



Input Signal for Mask B

Agilent 11:21:59 Oct 31, 2014 R T

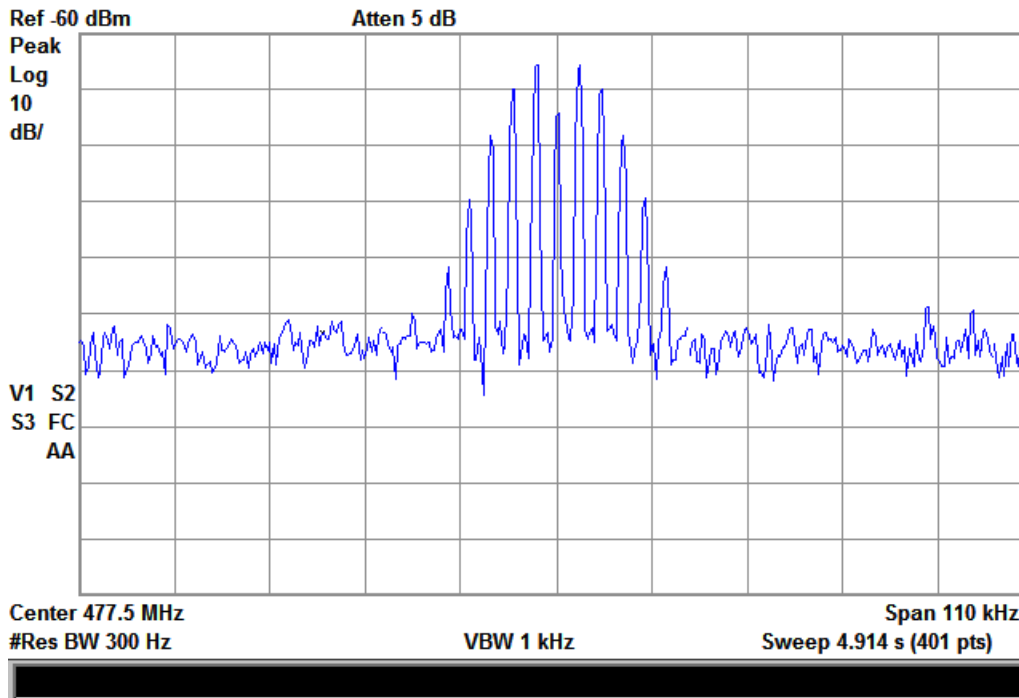

Mask B_Output Signal

Agilent 10:57:18 Jun 20, 2014 R T

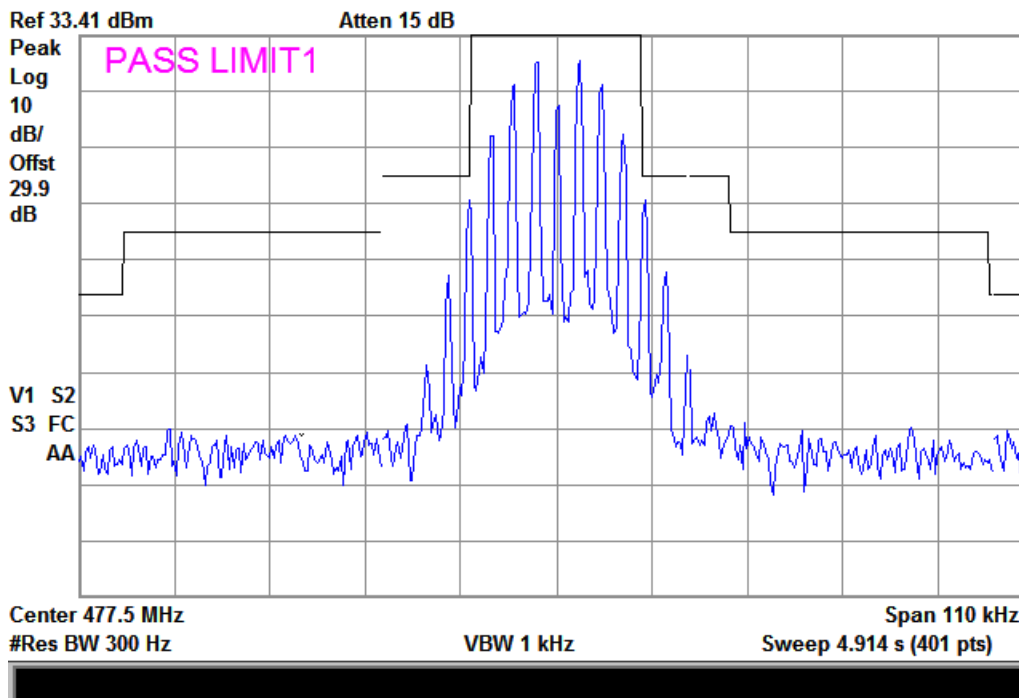



Input Signal for Mask D

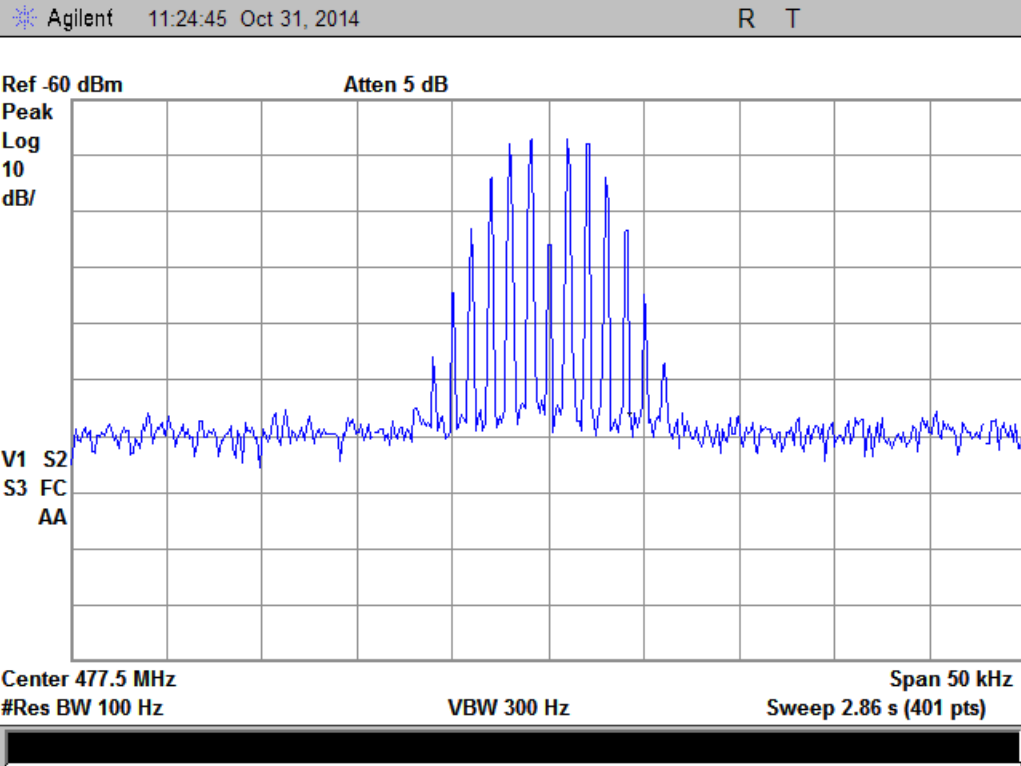

Mask D_Output Signal

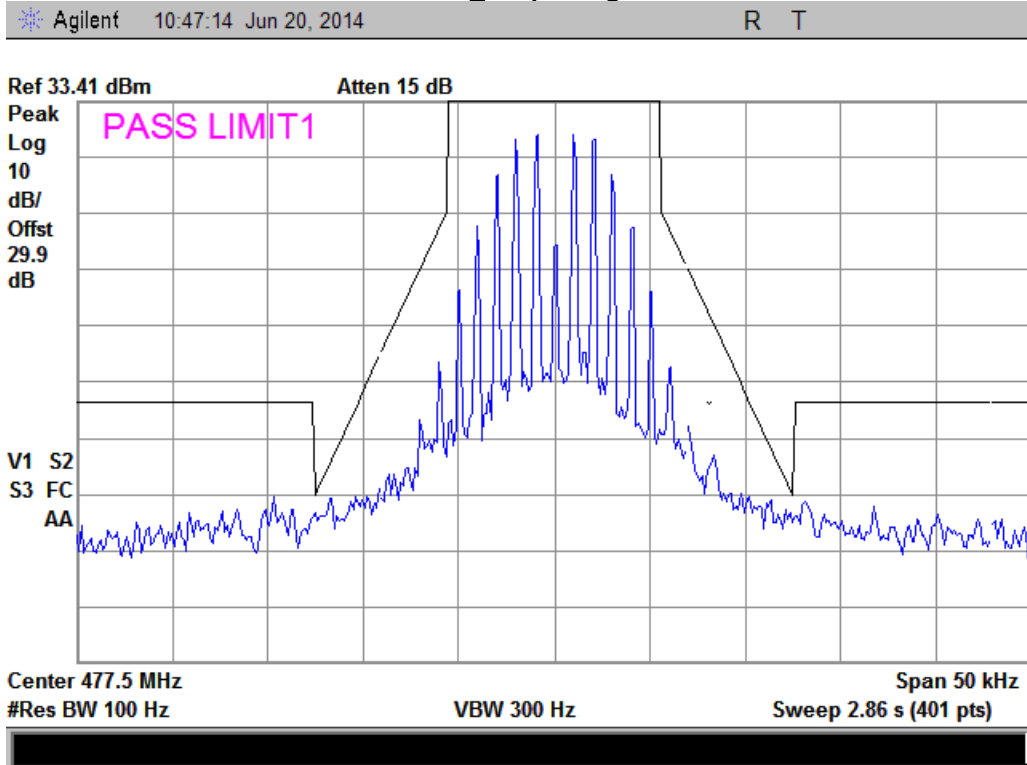



Input Signal for Mask E

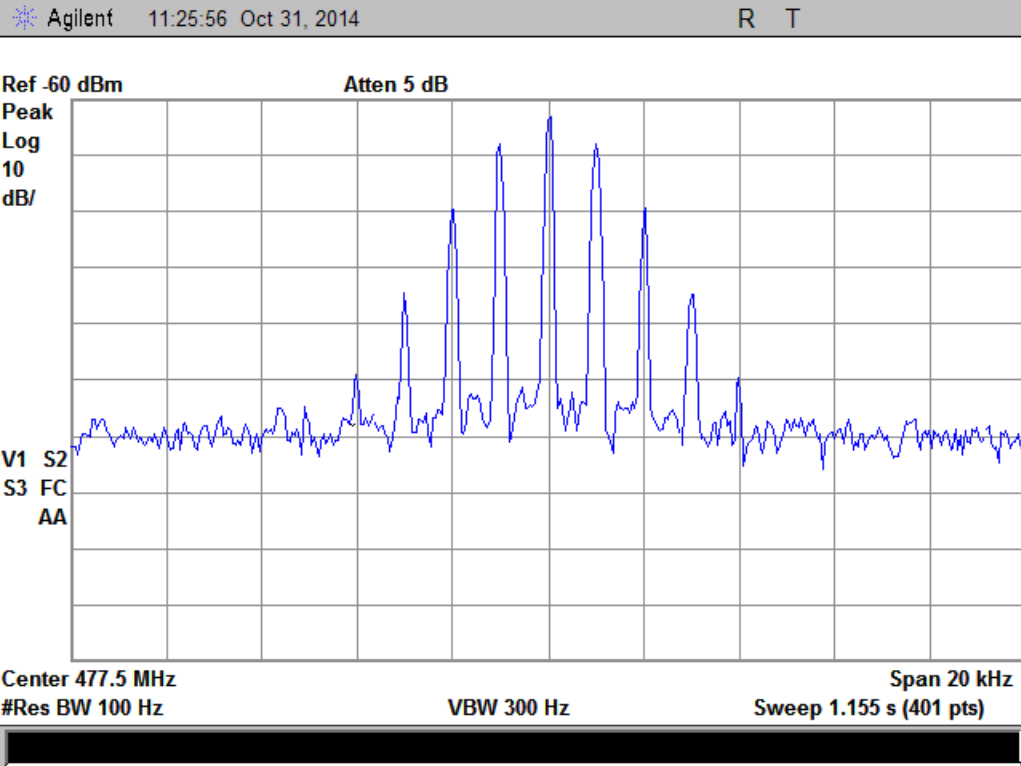

Mask E_Output Signal

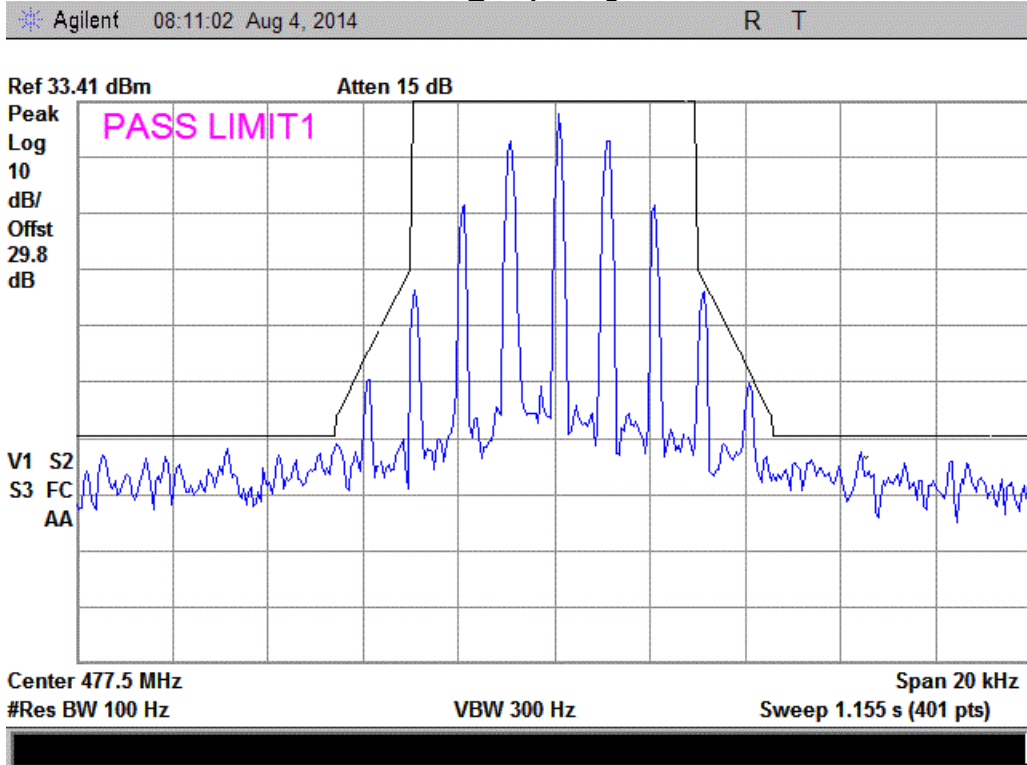



Uplink_High Power_473 - 488 MHz
Tuned Frequency = 480.5 MHz

Reference Plot for Mask

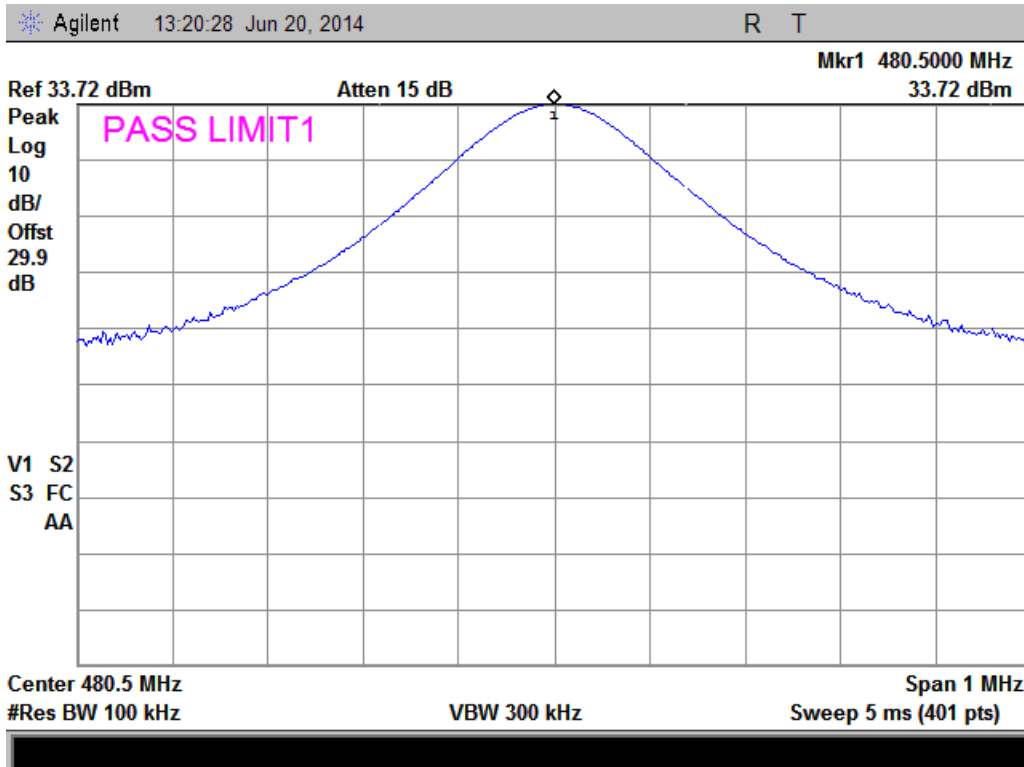



Input Signal for Mask B

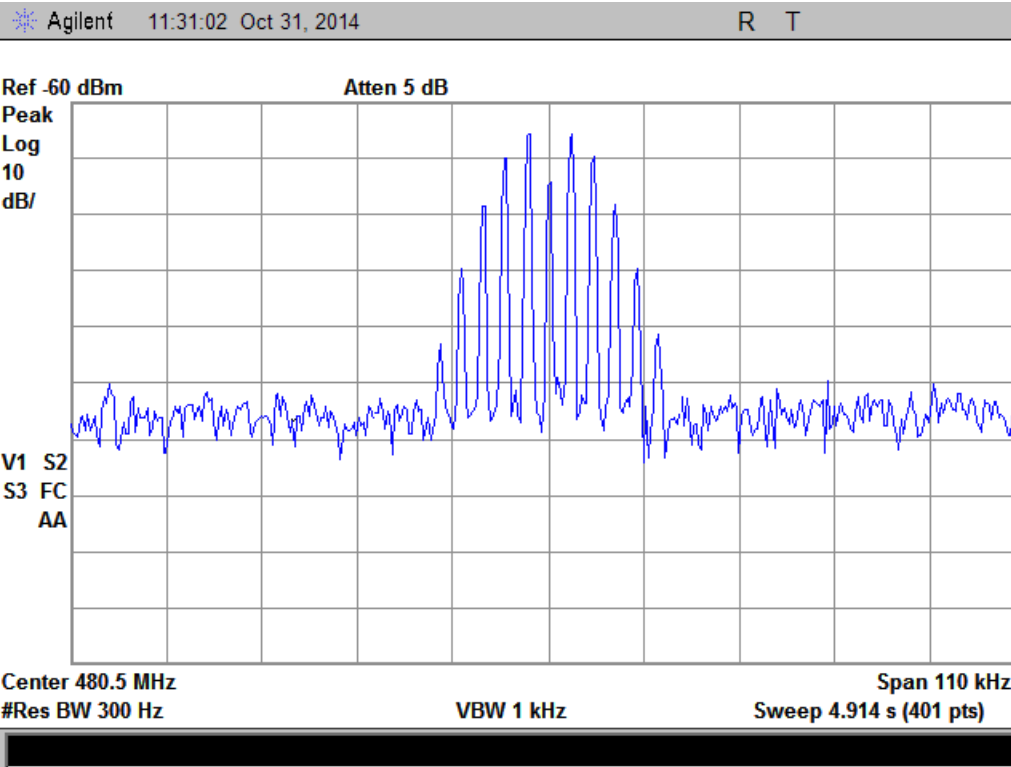

Mask B_Output Signal

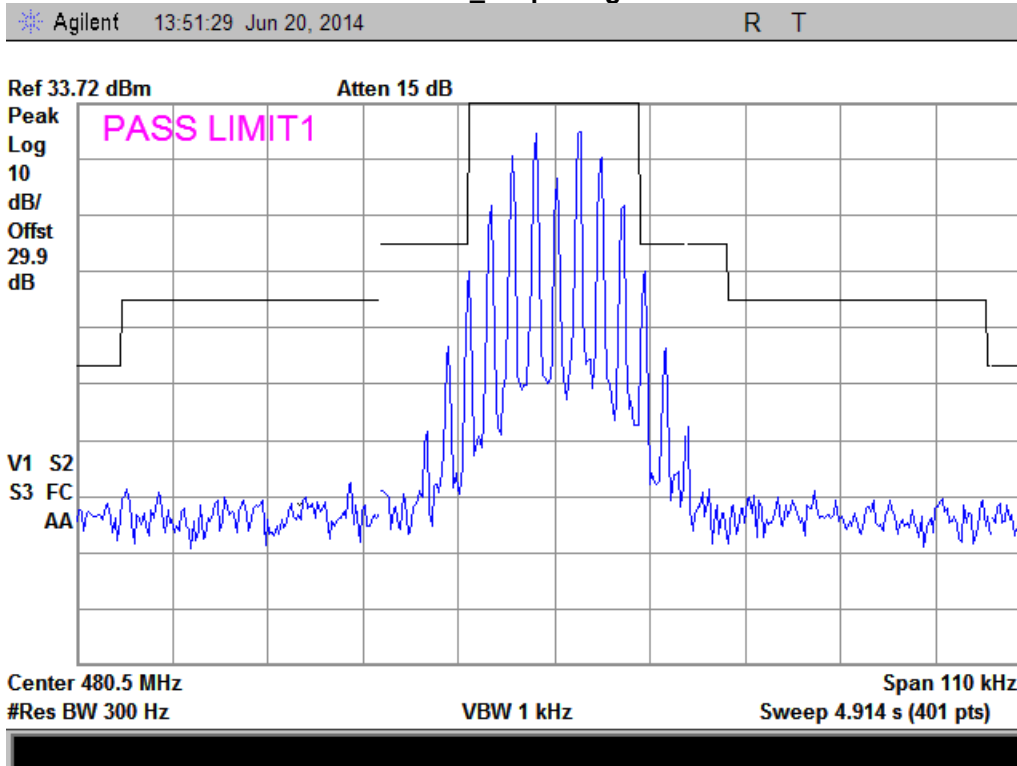



Input Signal for Mask D

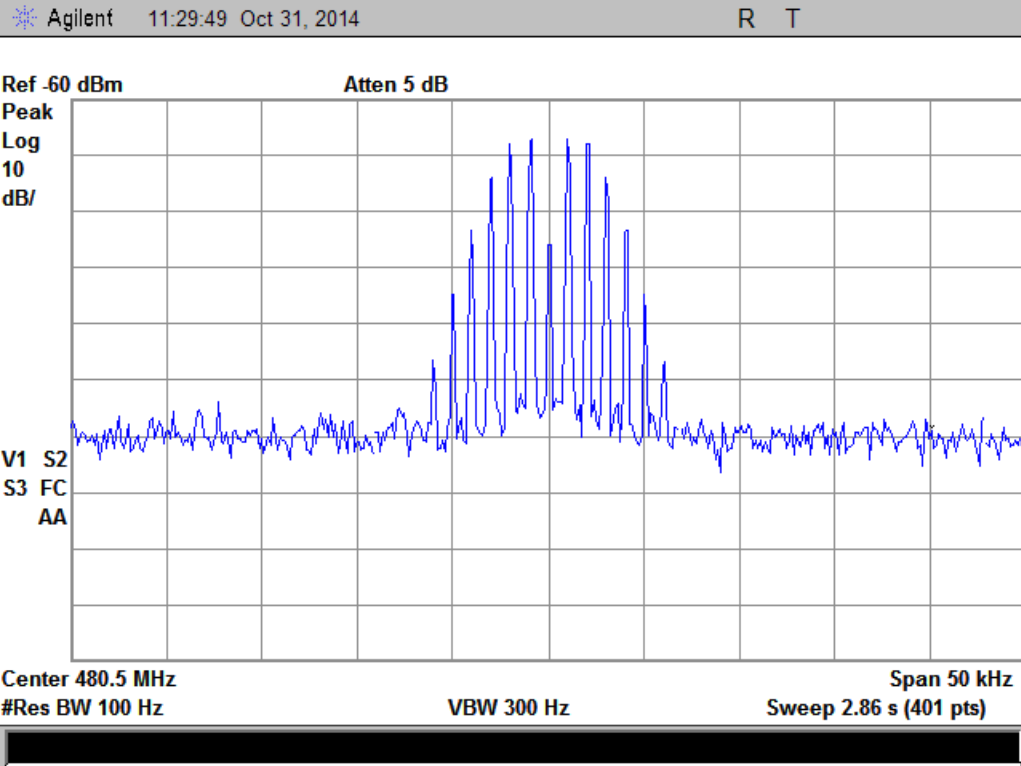

Mask D_Output Signal

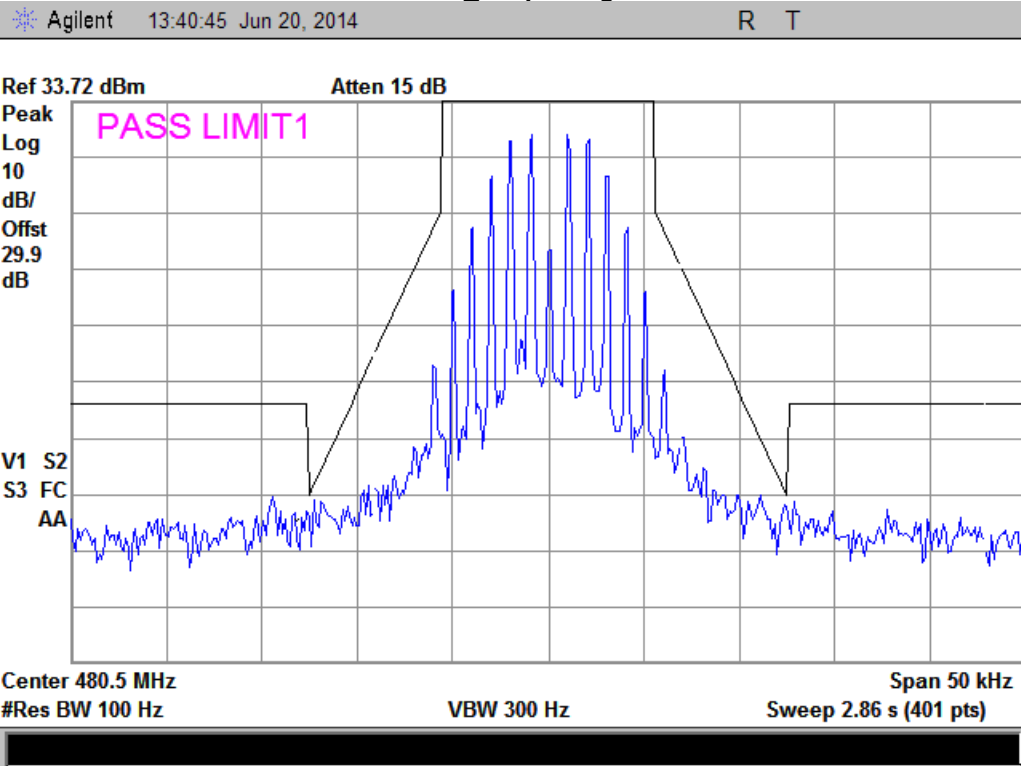



Input Signal for Mask E

Agilent 11:28:41 Oct 31, 2014 R T

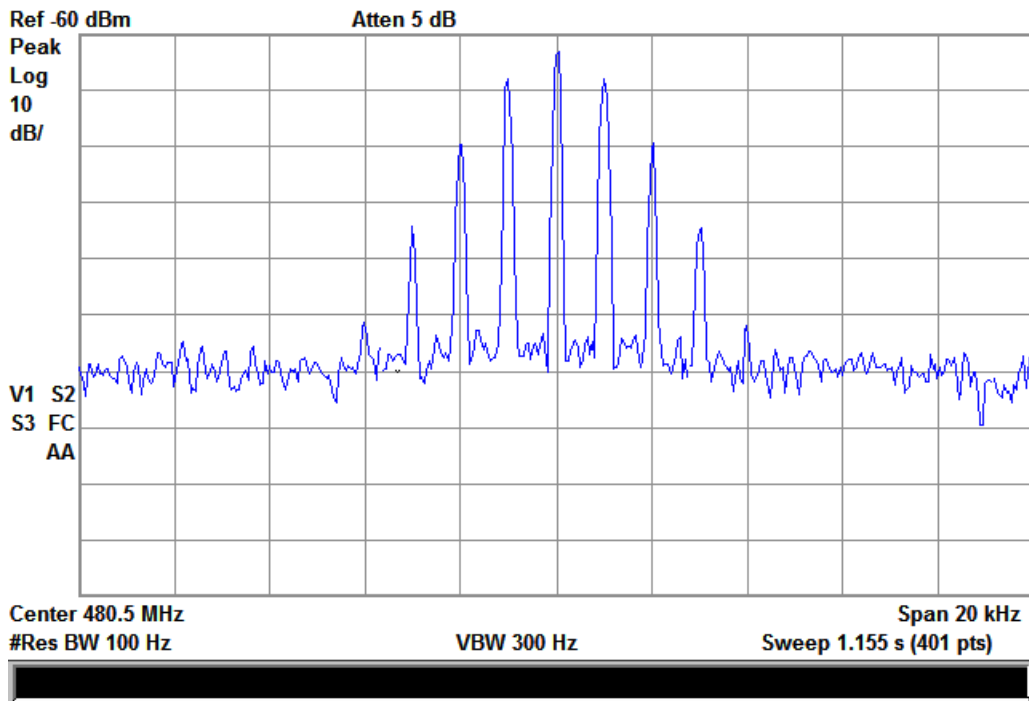

Mask E_Output Signal

Agilent 08:43:43 Aug 4, 2014 R T

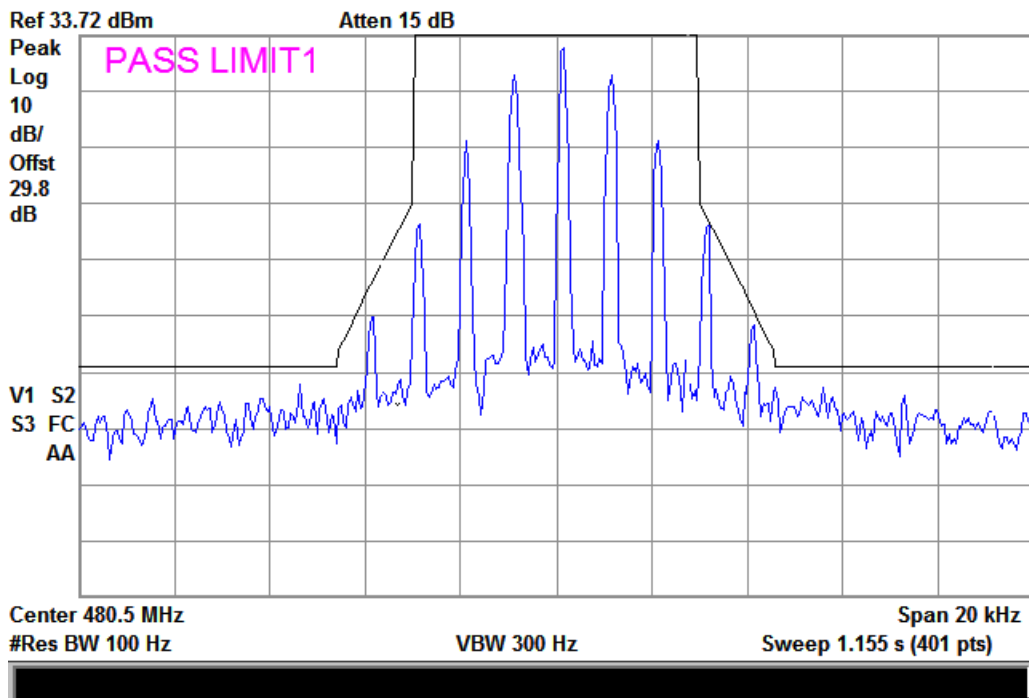



Intermodulation

Name of Test: Intermodulation
Test Equipment Utilized: i00405, i00424

Engineer: Greg Corbin
Test Date: 6/16/14

Test Procedure

The EUT was connected to a spectrum analyzer through a 20 dB power attenuator. Two signal generators were utilized to produce a two tone signal with the 12.5 KHz channel spacing set so the intermodulation products fell within the operational band. Frequency at the maximum power from out of band rejection was utilized.

The RF input signal level was set to 0.2 dB below the AGC Threshold.
RBW = 200 Hz
Video BW = 3x RBW

The downlink intermodulation products within the operational band were examined and the maximum amplitude from the intermodulation signals was recorded in tabular form.

Test Setup

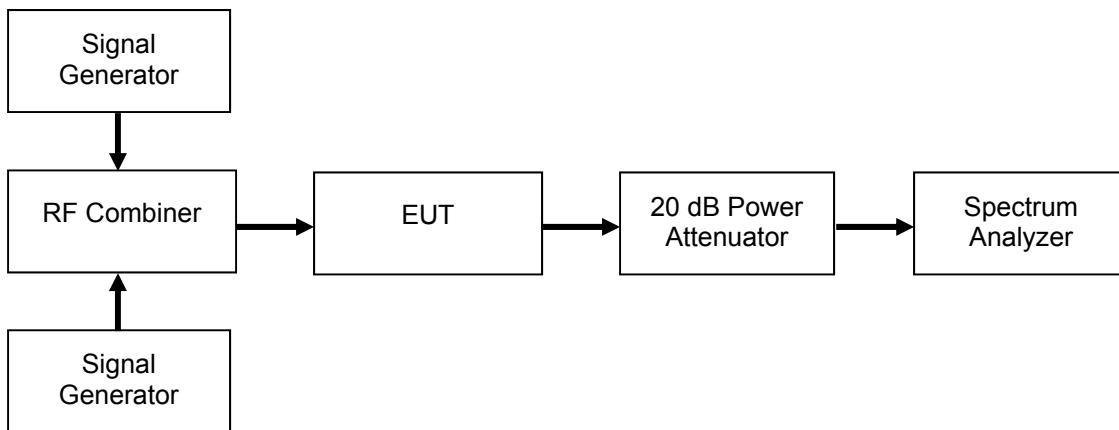



Downlink Intermodulation Test Results

Downlink Low Power MHz

Input Frequency (MHz)		Intermodulation Level (dBm)
470.50625	470.49375	-13.9

Downlink High Power MHz

Input Frequency (MHz)		Intermodulation Level (dBm)
470.04375	470.05625	-17.5

Uplink Low Power MHz

Input Frequency (MHz)		Intermodulation Level (dBm)
473.39375	473.40625	-13.7

Uplink High Power MHz

Input Frequency (MHz)		Intermodulation Level (dBm)
473.49375	473.50625	-15.3



Intermodulation Test Plots

Downlink Low Power MHz

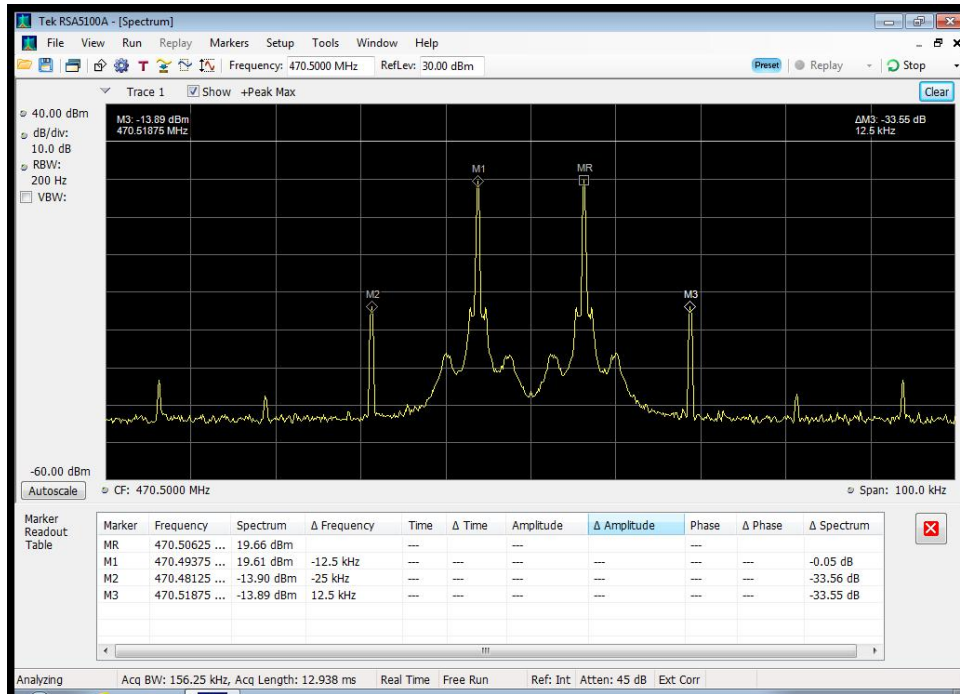

Downlink High Power MHz

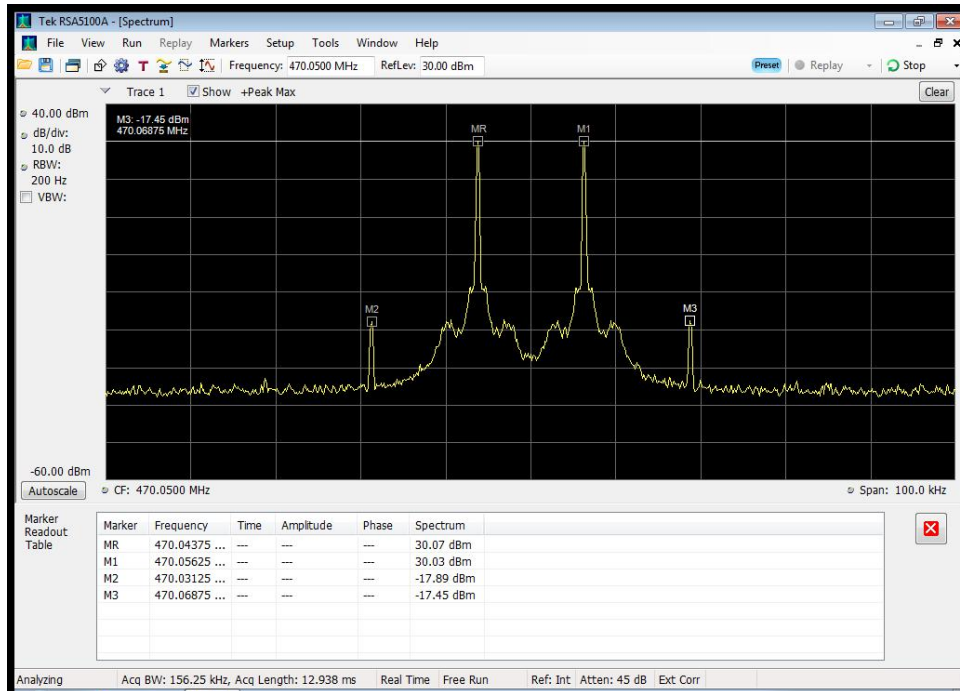



Uplink Low Power MHz

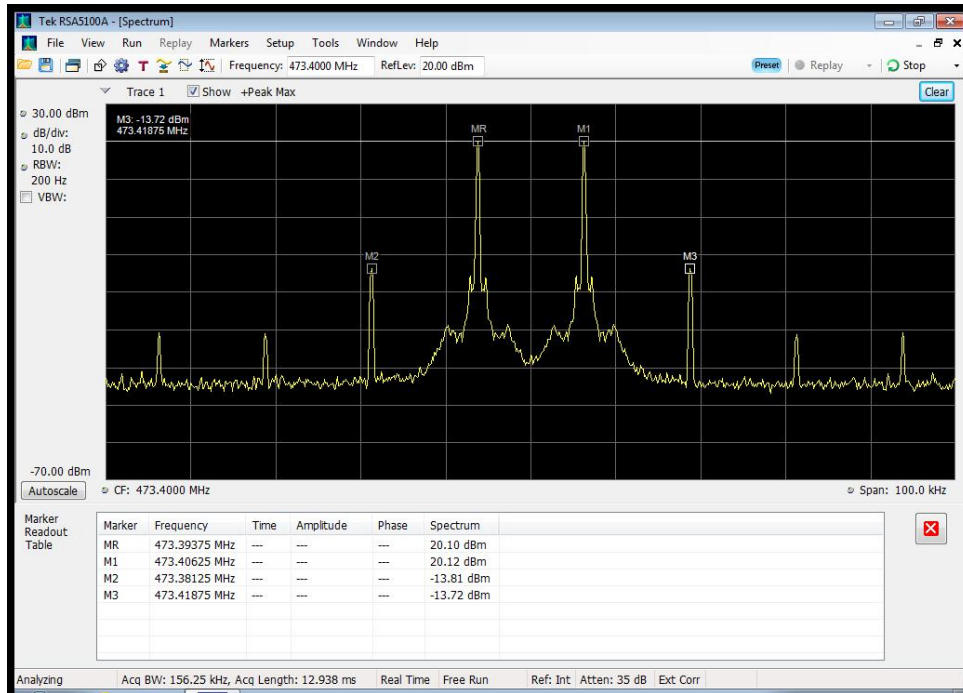

Uplink High Power 473 - 488 MHz

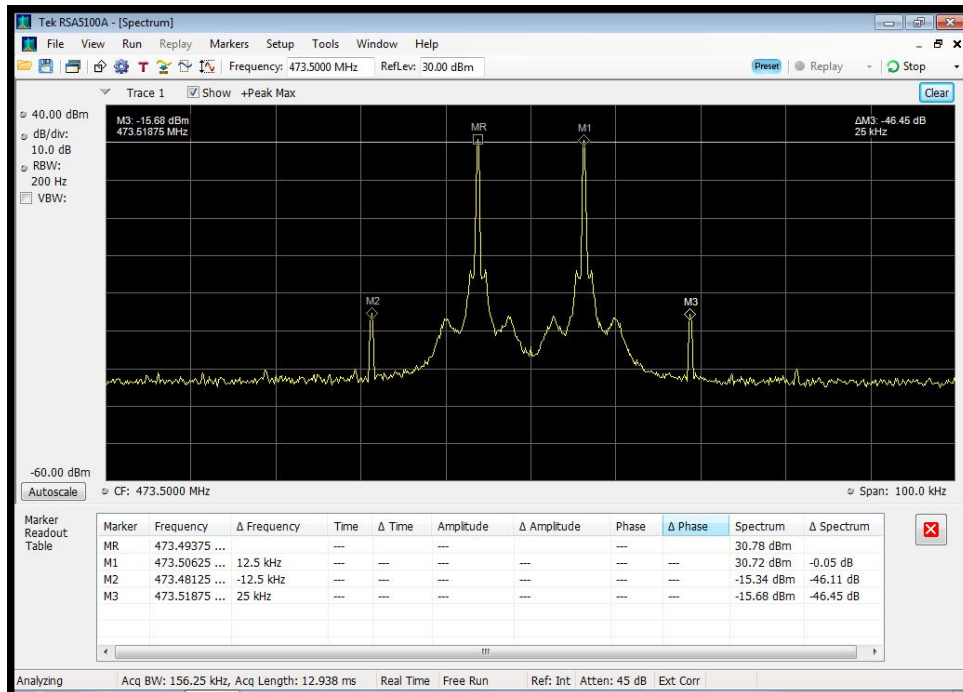



Noise Figure Test

Name of Test: Noise Figure
Test Equipment Utilized: N8973A, N4000A

Engineer: Greg Corbin
Test Date: 8/4/2014

Test Procedure

The test equipment was connected as shown in the test set-up.

The noise figure was measured at the passband center frequency.
Noise figure was measured using the high power output.



Operational Band	Test Frequency (MHz)	Noise Figure (dB)
Downlink 470 - 485 MHz	477.5	5.6
Uplink 473 - 488 MHz	480.5	5.1



Test Equipment Utilized

Description	Manufacturer	Model #	CT Asset #	Last Cal Date	Cal Due Date
Horn Antenna	EMCO	3115	i00103	12/11/12	12/11/14
Termination, High Power, 500 watts	Bird	8201	i00134	Verified on: 6/20/14	
Humidity / Temp Meter	Newport	IBTHX-W-5	i00282	3/24/14	3/24/15
Bi-Log Antenna	Schaffner	CBL 6111D	i00349	10/8/13	10/8/15
EMI Analyzer	Agilent	E7405A	i00379	1/14/14	1/14/15
Signal Generator	Rohde & Schwarz	SMU200A	i00405	12/11/13	12/11/14
Spectrum Analyzer	Textronix	RSA5126A	i00424	9/22/13	9/22/14
3 Meter Semi-Anechoic Chamber	Panashield	3 Meter Semi-Anechoic Chamber	i00428	11/26/13	11/26/15
Noise Figure Meter	Agilent	N8973A	Bird Technology	Verified 8-4-14	
Noise Source	Agilent	N4000A	Bird Technology	Verified 8-4-14	

In addition to the above listed equipment standard RF connectors and cables were utilized in the testing of the described equipment. Prior to testing these components were tested to verify proper operation.

END OF TEST REPORT



Test Setup Photos
FCC ID: EZZ61470A

RF Conducted #1



RF Conducted #2

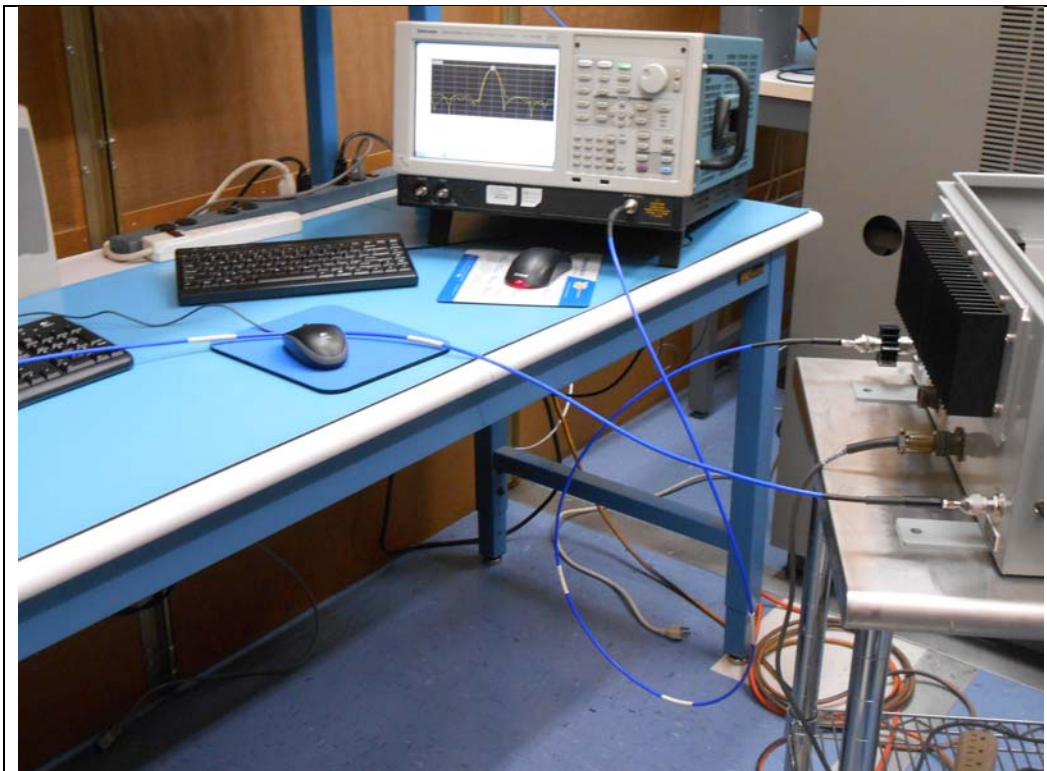



RF Radiated #1

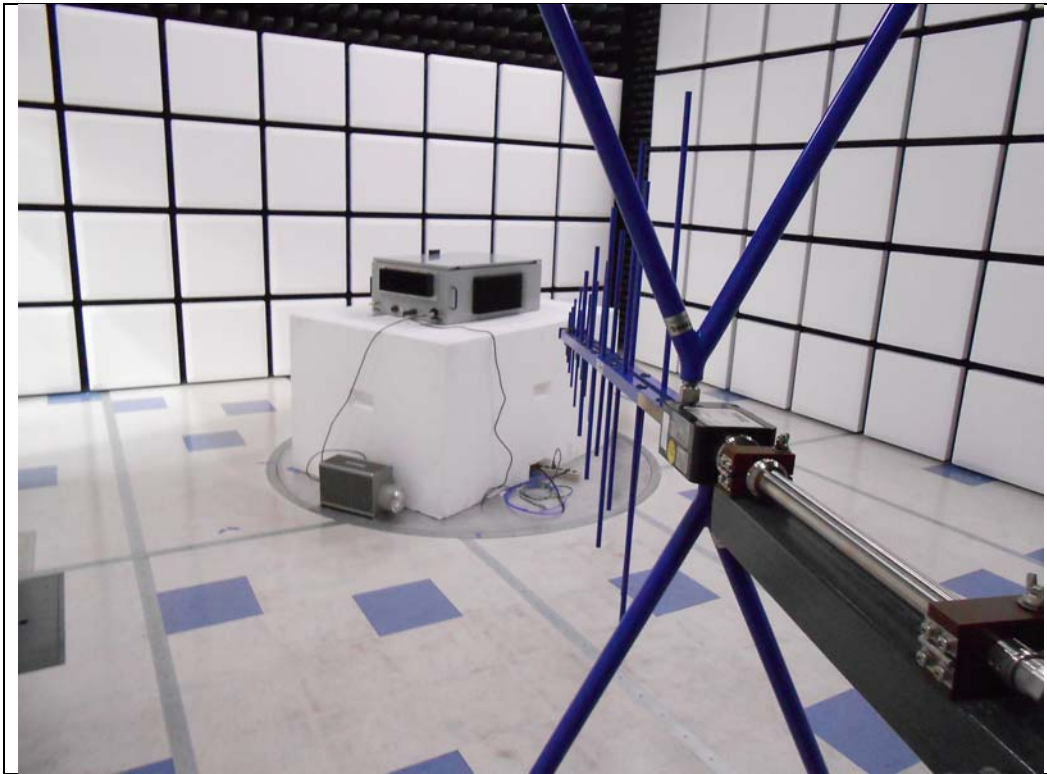

RF Radiated #2

