

ENGINEERING TEST REPORT

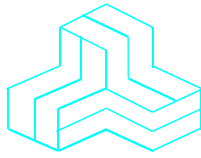

Signal Booster 2
Model No.: 61-88-50-A06-G1
FCC ID: EZZ5PI618850

Applicant:

TX RX Systems, Inc.
8625 Industrial Parkway
Angola, NY 14006
USA

Tested in Accordance With

Federal Communications Commission (FCC)
47 CFR, Parts 2 and 90 (Subpart I)

UltraTech's File No.: TXRX-009FCC90

This Test report is Issued under the Authority of
Tri M. Luu, Professional Engineer,
Vice President of Engineering
UltraTech Group of Labs

Date: October 14, 2004



Report Prepared by: Anca Dobre

Tested by: Hung Trinh, EMI/RFI Technician

Issued Date: October 14, 2004

Test Dates: August 16 – September 14, 2004

- *The results in this Test Report apply only to the sample(s) tested, and the sample tested is randomly selected.*
- *This report must not be used by the client to claim product endorsement by NVLAP or any agency of the US Government.*

UltraTech

3000 Bristol Circle, Oakville, Ontario, Canada, L6H 6G4
Tel.: (905) 829-1570 Fax: (905) 829-8050

Website: www.ultratech-labs.com, Email: vic@ultratech-labs.com, Email: tri@ultratech-labs.com



TABLE OF CONTENTS

EXHIBIT 1.	SUBMITTAL CHECK LIST.....	1
EXHIBIT 2.	INTRODUCTION	2
2.1.	SCOPE.....	2
2.2.	RELATED SUBMITTAL(S)/GRANT(S).....	2
2.3.	NORMATIVE REFERENCES	2
EXHIBIT 3.	PERFORMANCE ASSESSMENT	3
3.1.	CLIENT INFORMATION	3
3.2.	EQUIPMENT UNDER TEST (EUT) INFORMATION	3
3.3.	EUT'S TECHNICAL SPECIFICATIONS	4
3.4.	LIST OF EUT'S PORTS	5
3.5.	ANCILLARY EQUIPMENT	5
3.6.	GENERAL TEST SETUP	5
EXHIBIT 4.	EUT OPERATING CONDITIONS AND CONFIGURATIONS DURING TESTS.....	6
4.1.	CLIMATE TEST CONDITIONS	6
4.2.	OPERATIONAL TEST CONDITIONS & ARRANGEMENT FOR TEST SIGNALS	6
EXHIBIT 5.	SUMMARY OF TEST RESULTS	7
5.1.	LOCATION OF TESTS	7
5.2.	APPLICABILITY & SUMMARY OF EMC EMISSION TEST RESULTS	7
5.3.	MODIFICATIONS INCORPORATED IN THE EUT FOR COMPLIANCE PURPOSES	8
EXHIBIT 6.	MEASUREMENTS, EXAMINATIONS & TEST DATA FOR EMC EMISSIONS.....	9
6.1.	TEST PROCEDURES.....	9
6.2.	MEASUREMENT UNCERTAINTIES	9
6.3.	MEASUREMENT EQUIPMENT USED.....	9
6.4.	ESSENTIAL/PRIMARY FUNCTIONS AS DECLARED BY THE MANUFACTURER	9
6.5.	RF POWER OUTPUT & INTERMODULATION [§§ 2.1046 & 90.205].....	10
6.6.	RF EXPOSURE REQUIREMENTS [§§ 1.1310 & 2.1091]	25
6.7.	OCCUPIED BANDWIDTH AND EMISSION MASK [§§ 2.1049, 90.209 & 90.210].....	28
6.8.	TRANSMITTER ANTENNA POWER SPURIOUS/HARMONIC CONDUCTED EMISSIONS [§§ 2.1051, 90.209 & 90.210].....	66
6.9.	TRANSMITTER SPURIOUS/HARMONIC RADIATED EMISSIONS [§§ 90.208 & 90.210]	91
EXHIBIT 7.	MEASUREMENT UNCERTAINTY.....	94
7.1.	RADIATED EMISSION MEASUREMENT UNCERTAINTY	94
EXHIBIT 8.	MEASUREMENT METHODS.....	95
8.1.	CONDUCTED POWER MEASUREMENTS	95
8.2.	RADIATED POWER MEASUREMENTS (ERP & EIRP) USING SUBSTITUTION METHOD	96
8.3.	EMISSION MASK.....	99
8.4.	SPURIOUS EMISSIONS (CONDUCTED).....	99

EXHIBIT 1. SUBMITTAL CHECK LIST

Annex No.	Exhibit Type	Description of Contents	Quality Check (OK)
--	Test Report	<ul style="list-style-type: none"> • Exhibit 1: Submittal check lists • Exhibit 2: Introduction • Exhibit 3: Performance Assessment • Exhibit 4: EUT Operation and Configuration during Tests • Exhibit 5: Summary of test Results • Exhibit 6: Measurement Data • Exhibit 7: Measurement Uncertainty • Exhibit 8: Measurement Methods 	OK
1	Test Setup Photos	Radiated Emission Setup Photos	OK
2	External Photos of EUT	External Photos	OK
3	Internal Photos of EUT	Internal Photos	OK
4	Cover Letters	<ul style="list-style-type: none"> • Letter from Ultratech for Certification Request • Letter from the Applicant to appoint Ultratech to act as an agent • Letter from the Applicant to request for Confidentiality Filing 	OK
5	Attestation Statements	N/A	N/A
6	ID Label/Location Info	ID Label and Location of ID Label	OK
7	Block Diagrams	Block Diagram	OK
8	Schematic Diagrams	Schematics	OK
9	Parts List/Tune Up Info	Parts List/ Tuning Procedures	OK
10	Operational Description	Operational Description	OK
11	RF Exposure Info	See Section 6.6 of this test report for MPE evaluation	OK
12	Users Manual	Users Manual	OK

ULTRATECH GROUP OF LABS

3000 Bristol Circle, Oakville, Ontario, Canada L6H 6G4
 Tel. #: 905-829-1570, Fax. #: 905-829-8050, Email: vic@ultratech-labs.com, Website: <http://www.ultratech-labs.com>

File #: TXRX-009FCC90

October 14, 2004

All test results contained in this engineering test report are traceable to National Institute of Standards and Technology (NIST)

EXHIBIT 2. INTRODUCTION

2.1. SCOPE

Reference:	FCC Parts 2 and 90
Title:	Code of Federal Regulations (CFR) Title 47 - Telecommunication, Parts 2 and 90 (Subpart I).
Purpose of Test:	To gain FCC Certification Authorization for Radio operating in the frequency bands 896-901 MHz (Uplink) and 935-940 MHz (Downlink).
Test Procedures:	Both conducted and radiated emissions measurements were conducted in accordance with American National Standards Institute ANSI C63.4 - American National Standard for Methods of Measurement of Radio-Noise Emissions from Low-Voltage Electrical and Electronic Equipment in the Range of 9 kHz to 40 GHz.
Environmental Classification:	Commercial, industrial or business

2.2. RELATED SUBMITTAL(S)/GRANT(S)

None.

2.3. NORMATIVE REFERENCES

Publication	Year	Title
FCC CFR Parts 0-19, 80-End	2003	Code of Federal Regulations – Telecommunication
ANSI C63.4	2003	American National Standard for Methods of Measurement of Radio-Noise Emissions from Low-Voltage Electrical and Electronic Equipment in the Range of 9 kHz to 40 GHz
CISPR 22 & EN 55022	2003 2003	Limits and Methods of Measurements of Radio Disturbance Characteristics of Information Technology Equipment
CISPR 16-1	2003	Specification for Radio Disturbance and Immunity measuring apparatus and methods

EXHIBIT 3. PERFORMANCE ASSESSMENT

3.1. CLIENT INFORMATION

APPLICANT	
Name:	TX RX Systems, Inc.
Address:	8625 Industrial Parkway Angola, NY 14006 USA
Contact Person:	Mr. Dennis Hohman Phone #: (716) 549-4700 ext 5080 Fax #: (716) 549-4772 Email Address: dennish@txrx.com

MANUFACTURER	
Name:	TX RX Systems, Inc.
Address:	8625 Industrial Parkway Angola, NY 14006 USA
Contact Person:	Mr. Dennis Hohman Phone #: (716) 549-4700 ext 5080 Fax #: (716) 549-4772 Email Address: dennish@txrx.com

3.2. EQUIPMENT UNDER TEST (EUT) INFORMATION

The following information (with the exception of the Date of Receipt) has been supplied by the applicant.

Brand Name:	TX RX Systems, Inc.
Product Name:	Signal Booster 2
Model Name or Number:	61-88-50-A06-G1
Type of Equipment:	Non-broadcast Radio Communication Equipment
External Power Supply:	120 V / 60 Hz
Primary User functions of EUT:	Signal Booster 2 extends radio coverage into areas where abrupt propagation losses prevent reliable communication. It receives an RF signal, raises its power level and couples it to an antenna so that it can be re-radiated.
Transmitting/Receiving Antenna Type:	Non-Integral

ULTRATECH GROUP OF LABS

3000 Bristol Circle, Oakville, Ontario, Canada L6H 6G4
Tel. #: 905-829-1570, Fax. #: 905-829-8050, Email: vic@ultratech-labs.com, Website: <http://www.ultratech-labs.com>

File #: TXRX-009FCC90
October 14, 2004

All test results contained in this engineering test report are traceable to National Institute of Standards and Technology (NIST)

3.3. EUT'S TECHNICAL SPECIFICATIONS

TRANSMITTER	
Equipment Type:	Base station (fixed use)
Intended Operating Environment:	Commercial, industrial or business environment
Power Supply Requirement:	120 V / 60 Hz
RF Input Power Rating:	0 dBm for single channel input/output
RF Output Power Rating:	3.16 Watts for 896-901 MHz and 935-940 MHz
Operating Frequency Range:	<ul style="list-style-type: none"> • 896-901 MHz (uplink) • 935-940 MHz (downlink)
RF Output Impedance:	50 Ohms
Occupied Bandwidth (99%):	EXTENDER (The 99% OBW of the rf output signal is the same as that of the rf input signal from a FCC certified transmitter)
Emission Designation:	<ul style="list-style-type: none"> • F1D • F3E • G3E
Antenna Connector Type:	N Female
Antenna Description:	<ul style="list-style-type: none"> • Outdoor/Top-Roof Antenna: The Antenna Gain Limit is 10 dB • In-building antenna: radiating coaxial cable or a network ¼ wave whip antenna (gain not exceed 0 dB)

RECEIVER	
Equipment Type:	Base station (fixed use)
Intended Operating Environment:	Commercial, industrial or business environment
Power Supply Requirement:	120 V/ 60 Hz
RF Input Power Rating:	0 dBm for single channel input/output
Operating Frequency Range:	<ul style="list-style-type: none"> ▪ 896-901 MHz (uplink) ▪ 935-940 MHz (downlink)

3.4. LIST OF EUT'S PORTS

Port Number	EUT's Port Description	Number of Identical Ports	Connector Type	Cable Type (Shielded/Non-shielded)
1	Downlink In / Uplink out	1	N female	Shielded
2	Uplink In / Downlink out	1	N female	Shielded
3	Power Port	1	3 prong	Non-shielded

3.5. ANCILLARY EQUIPMENT

None.

3.6. GENERAL TEST SETUP

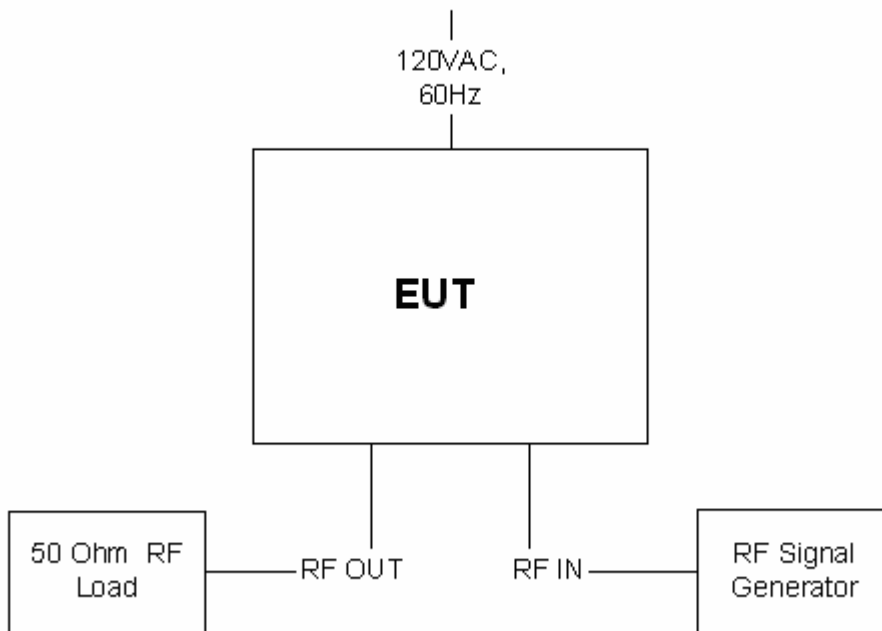

EXHIBIT 4. EUT OPERATING CONDITIONS AND CONFIGURATIONS DURING TESTS

4.1. CLIMATE TEST CONDITIONS

The climate conditions of the test environment are as follows:

Temperature:	21°C
Humidity:	51%
Pressure:	102 kPa
Power input source:	120 V / 60 Hz

4.2. OPERATIONAL TEST CONDITIONS & ARRANGEMENT FOR TEST SIGNALS

Operating Modes:	The transmitter was operated in a continuous transmission mode with the carrier modulated as specified in the Test Data.
Special Test Software:	N/A
Special Hardware Used:	N/A
Transmitter Test Antenna:	The EUT is tested with the transmitter antenna port terminated to a 50 Ohms RF Load.

Transmitter Test Signals	
Frequency Band(s):	<ul style="list-style-type: none"> ▪ 896-901 MHz ▪ 935-940 MHz
Frequency(ies) Tested: (Near lowest and near highest frequencies in the frequency range of operation.)	<ul style="list-style-type: none"> ▪ 896 & 901 MHz ▪ 935 & 940 MHz
RF Power Output (measured maximum output power):	3.6 Watts
Normal Test Modulation:	Unmodulated, F1D, F3E & G3E
Modulating signal source:	External

EXHIBIT 5. SUMMARY OF TEST RESULTS

5.1. LOCATION OF TESTS

All of the measurements described in this report were performed at Ultratech Group of Labs located in the city of Oakville, Province of Ontario, Canada.

- AC Power Line Conducted Emissions were performed in UltraTech's shielded room, 24'(L) by 16'(W) by 8'(H).
- Radiated Emissions were performed at the Ultratech's 3 Meter Open Field Test Site (OFTS) situated in the Town of Oakville, province of Ontario.

The above sites have been calibrated in accordance with ANSI C63.4, and found to be in compliance with the requirements of Sec. 2.948 of the FCC Rules. The descriptions and site measurement data of the Oakville Open Field Test Site has been filed with FCC office (FCC File No.: 31040/SIT 1300B3) and Industry Canada office (Industry Canada File No.: IC2049). Last Date of Site Calibration: February 17, 2004.

5.2. APPLICABILITY & SUMMARY OF EMC EMISSION TEST RESULTS

FCC Section(s)	Test Requirements	Applicability (Yes/No)
2.1046 & 90.205	RF Power Output & Intermodulation	Yes
1.1307, 1.1310, 2.1091 & 2.1093	RF Exposure Limit	Yes
2.1055 & 90.213	Frequency Stability	⁽¹⁾ Not applicable for amplifier
2.1047(a) & 90.242(b)(8)	Audio Frequency Response	⁽²⁾ Not applicable for amplifier
2.1047(b) & 90.210	Modulation Limiting	⁽²⁾ Not applicable for amplifier
2.1049 & 90.210	Emission Limitation & Emission Mask	Yes
2.1051, 2.1057 & 90.210	Emission Limits - Spurious Emissions at Antenna Terminal	Yes
2.1053, 2.1057 & 90.210	Emission Limits - Field Strength of Spurious Emissions	Yes

Signal Booster 2, Model No.: 61-88-50-A06-G1, by **TX RX Systems, Inc.** has also been tested and found to comply with **FCC Part 15, Subpart B - Radio Receivers and Class B Digital Devices**. The engineering test report has been documented and it is available upon request.

Notes:

- (1) Test is not applicable, the EUT is not designed to generate or translate frequencies, it only amplifies the signal it receives.
 (2) Test is not applicable, the EUT does not contain modulation circuitry.

5.3. MODIFICATIONS INCORPORATED IN THE EUT FOR COMPLIANCE PURPOSES

The only change was the addition of a filter as close to the ac input in order to comply with AC conducted emissions. See the following picture for details.



EXHIBIT 6. MEASUREMENTS, EXAMINATIONS & TEST DATA FOR EMC EMISSIONS

6.1. TEST PROCEDURES

This section contains test results only. Details of test methods and procedures can be found in Exhibit 8 of this report

6.2. MEASUREMENT UNCERTAINTIES

The measurement uncertainties stated were calculated in accordance with requirements of UKAS Document NIS 81 with a confidence level of 95%. Please refer to Exhibit 7 for Measurement Uncertainties.

6.3. MEASUREMENT EQUIPMENT USED

The measurement equipment used complied with the requirements of the Standards referenced in the Methods & Procedures ANSI C63.4 and CISPR 16-1.

6.4. ESSENTIAL/PRIMARY FUNCTIONS AS DECLARED BY THE MANUFACTURER

The essential function of the EUT is to receive an RF signal, raises its power, and couples it to an antenna so that it can be re-radiated.

6.5. RF POWER OUTPUT & INTERMODULATION [§§ 2.1046 & 90.205]

6.5.1. Limits

Please refer to FCC 47 CFR 90.205 for specification details.

6.5.2. Method of Measurements

Refer to ULTRATECH Test Procedures, File # ULTR P001-2004, ANSI C63.4 and Exhibit 8, section 8.1 (Conducted) and 8.2 (Radiated) of this report for measurement details.

6.5.3. Test Equipment List

Test Instruments	Manufacturer	Model No.	Serial No.	Frequency Range
Signal Generator	Gigatronic	6061A	5130586	10 kHz - 1050 MHz
Signal Generator	Fluke	6061A	4770301	10 kHz - 1050 MHz
Signal Generator	Gigatronic	6061A	5130408	10 kHz - 1050 MHz
Combiner	Mini-Circuit	15542	0105	1 MHz – 1 GHz
Spectrum Analyzer	Rohde & Schwarz	FSEK20/B4/B21	834157/005	9 kHz – 40 GHz

6.5.4. Test Arrangement

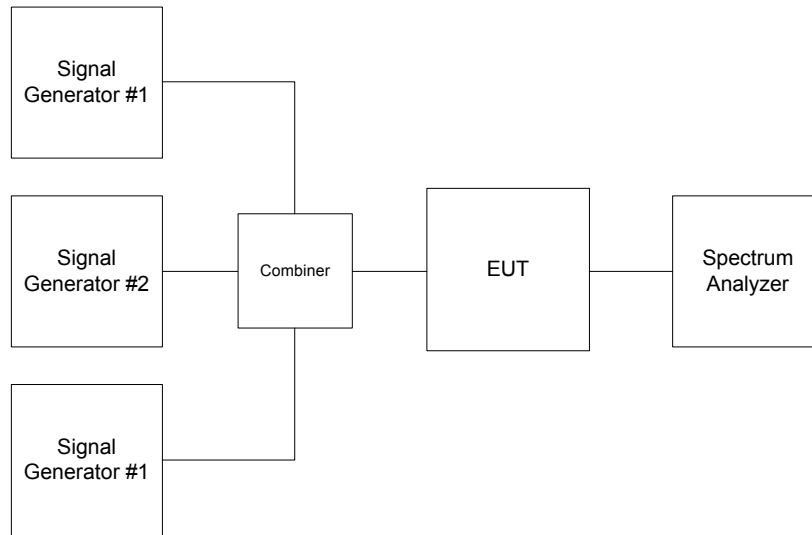

6.5.5. Test Data

6.5.5.1. RF POWER OUTPUT with MODULATION, SINGLE CHANNEL, MAXIMUM RF IN = 0 dBm

Operating Frequency Bands (MHz)	Test Frequency (MHz)	Modulation	Total RF Output Power at Antenna Port (dBm)	Maximum Antenna Gain (dB)	Maximum ERP (dBm)	RF Output Power Ratings at Antenna Port (dBm)
896 - 901	896	F1D/F3E/G3E	35.5	10	45.5	35
	901	F1D/F3E/G3E	35.3	10	45.3	35
935 - 940	935	F1D/F3E/G3E	35.6	0	35.6	35
	940	F1D/F3E/G3E	35.2	0	35.2	35

6.5.5.2. INTERMODULATION & PEAK POWERS IN 896-901 MHz BAND – NO MODULATION

Frequency (MHz)	Number of In/Out Channels	Modulation	Maximum RF Input (conducted) (dBm)	Maximum RF Output (conducted) (dBm)	Maximum Antenna Gain allowed (dB)	Maximum ERP Measured (dBm)	Manufacturer's Maximum RF Output Rating (conducted) (dBm)
896	1	unmodulated	0	34.7	10	44.6	35
896.0 896.0125	2	unmodulated	-54.0	31.6	10	41.6	35
896.0 896.0125 896.0250	3	unmodulated	-58.5	27.1	10	37.1	35
901	1	unmodulated	0	34.5	10	44.5	35
900.9875 901.0	2	unmodulated	-54.0	29.2	10	39.2	35
900.9750 900.9875 901.0	3	unmodulated	-57.5	25.8	10	35.8	35

See the following plots (# 1-6) for Intermodulation in the 896-901 MHz band.

PLOT # 1 Intermodulation with 1 RF signal input/output in 896-901 MHz Band
Fc: 896 MHz
RF Input: 0 dBm

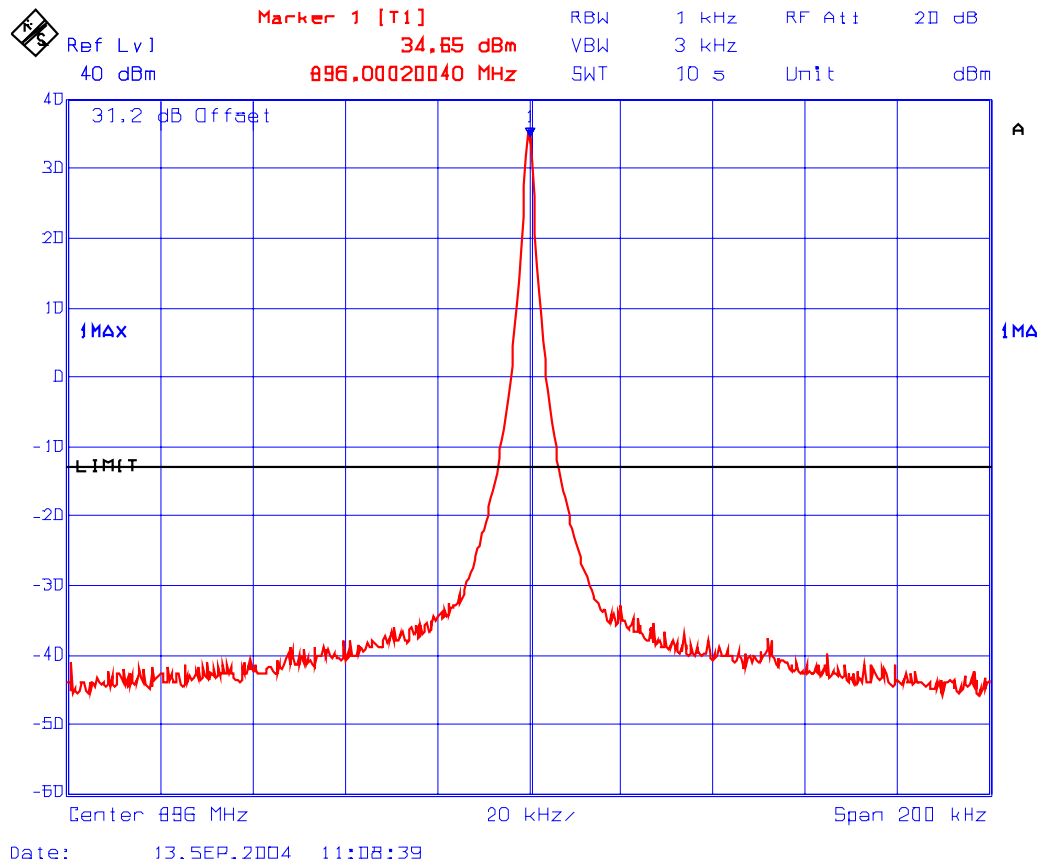

ULTRATECH GROUP OF LABS

3000 Bristol Circle, Oakville, Ontario, Canada L6H 6G4
Tel. #: 905-829-1570, Fax. #: 905-829-8050, Email: vic@ultratech-labs.com, Website: <http://www.ultratech-labs.com>

File #: TXRX-009FCC90

October 14, 2004

All test results contained in this engineering test report are traceable to National Institute of Standards and Technology (NIST)

PLOT # 2 Intermodulation with 2 RF signal inputs/outputs in 896-901 MHz Band
Fc: 896 MHz & Fc + 12.5 kHz
RF Input: (1) -54.03 dBm, (2) -53.99 dBm

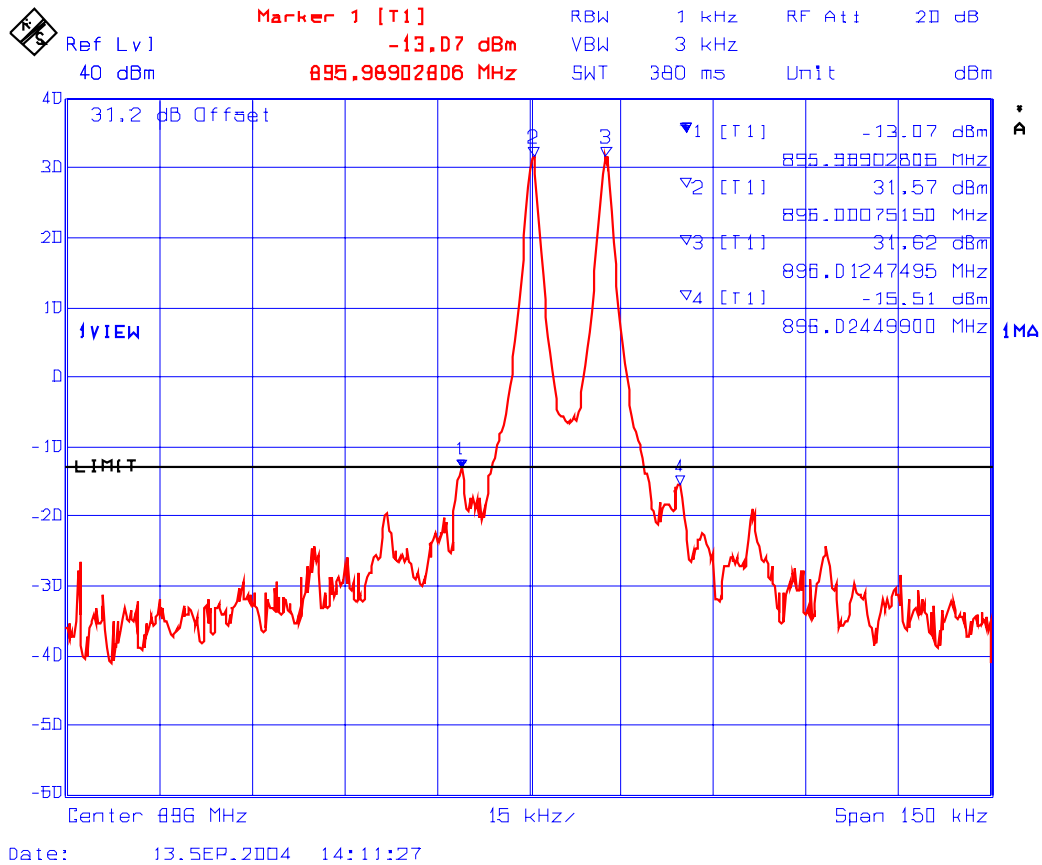

PLOT # 3 Intermodulation with 3 RF signal inputs/outputs in 896-901 MHz Band
Fc: 896 MHz, Fc + 12.5 kHz & Fc + 25 kHz,
RF Input: (1) -58.59 dBm, (2) -58.51 dBm, (3) -58.50 dBm

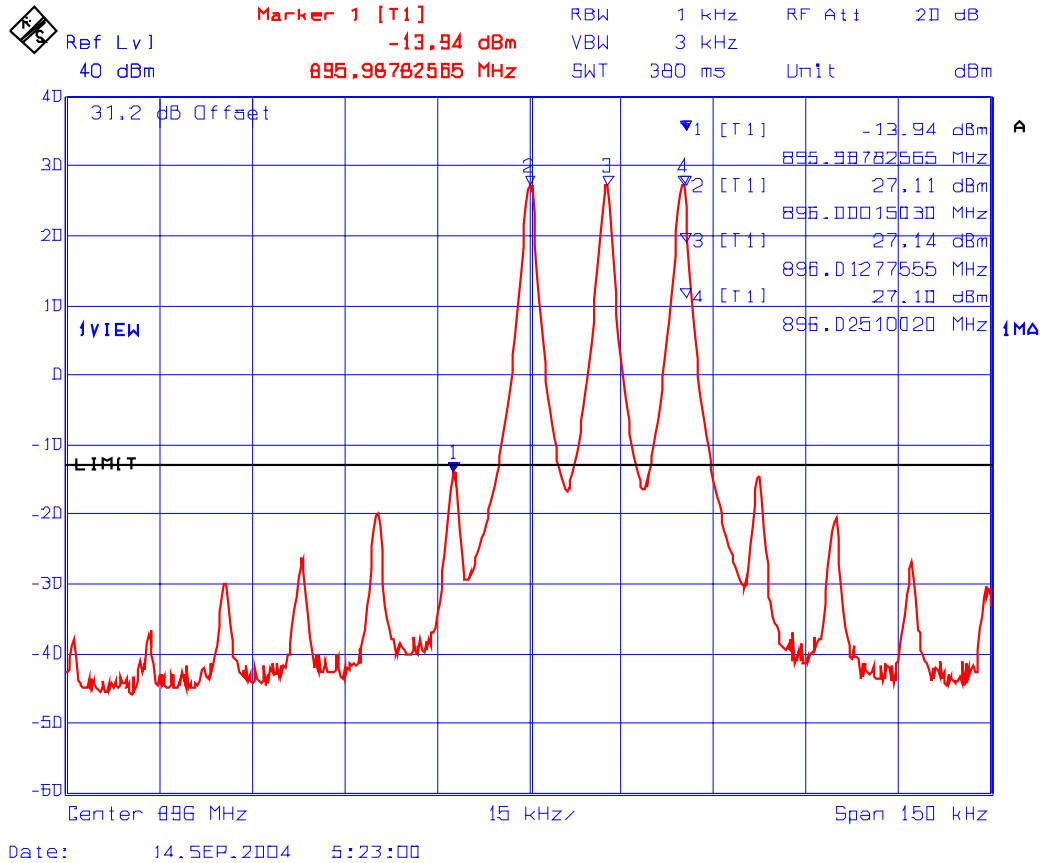

PLOT # 4 Intermodulation with 1 RF signal input/output in 896-901 MHz Band
Fc: 901 MHz
RF Input: 0 dBm

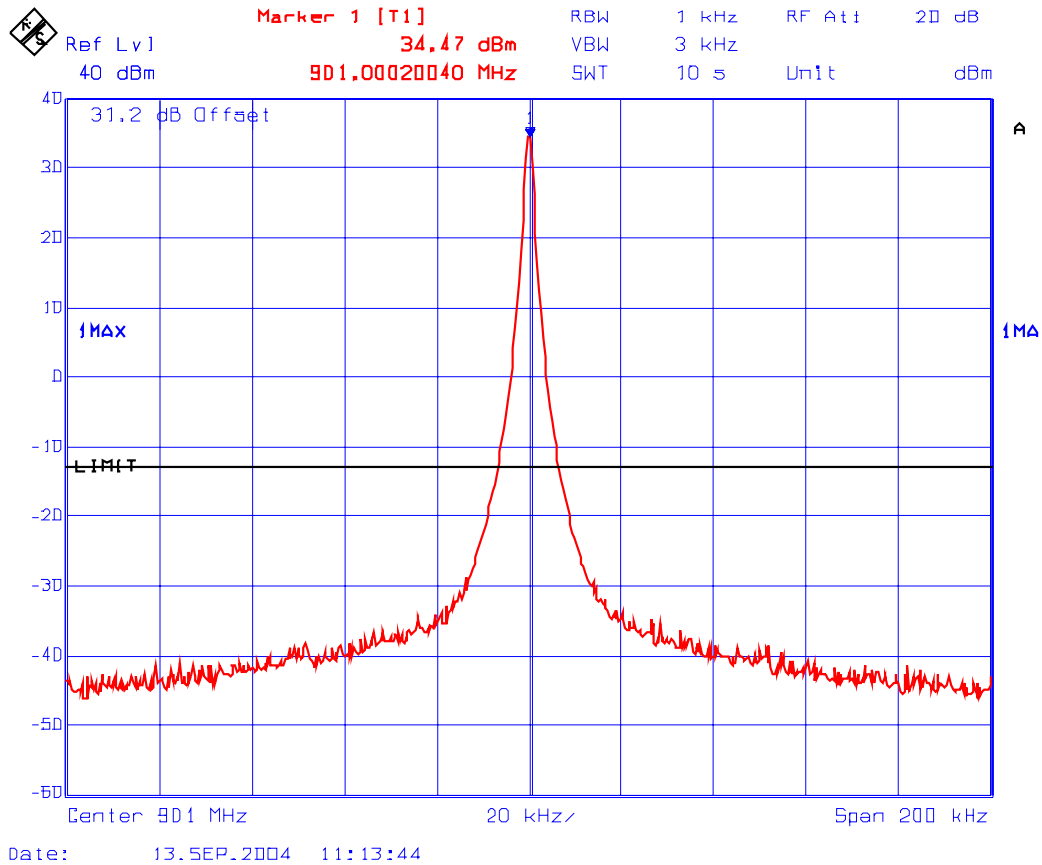

ULTRATECH GROUP OF LABS

3000 Bristol Circle, Oakville, Ontario, Canada L6H 6G4
Tel. #: 905-829-1570, Fax. #: 905-829-8050, Email: vic@ultratech-labs.com, Website: <http://www.ultratech-labs.com>

File #: TXRX-009FCC90

October 14, 2004

All test results contained in this engineering test report are traceable to National Institute of Standards and Technology (NIST)

PLOT # 5 Intermodulation with 2 RF signal inputs/outputs in 896-901 MHz Band
Fc: 901 MHz & Fc – 12.5 kHz
RF Input: (1) -54.01 dBm, (2) -54.08 dBm

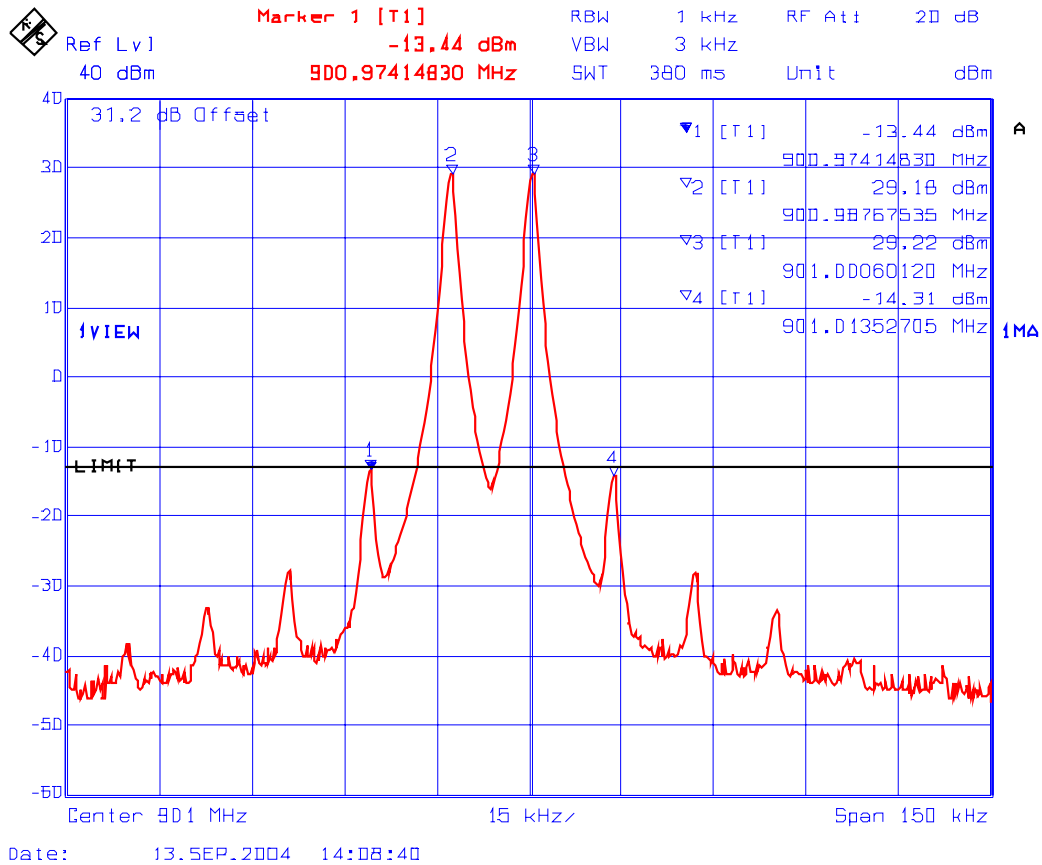

PLOT # 6 Intermodulation with 3 RF signal inputs/outputs in 896-901 MHz Band
Fc: 901 MHz, Fc -12.5kHz & Fc - 25 kHz
RF Input: (1) -57.58 dBm, (2) -57.45 dBm, (3) -57.58 dBm

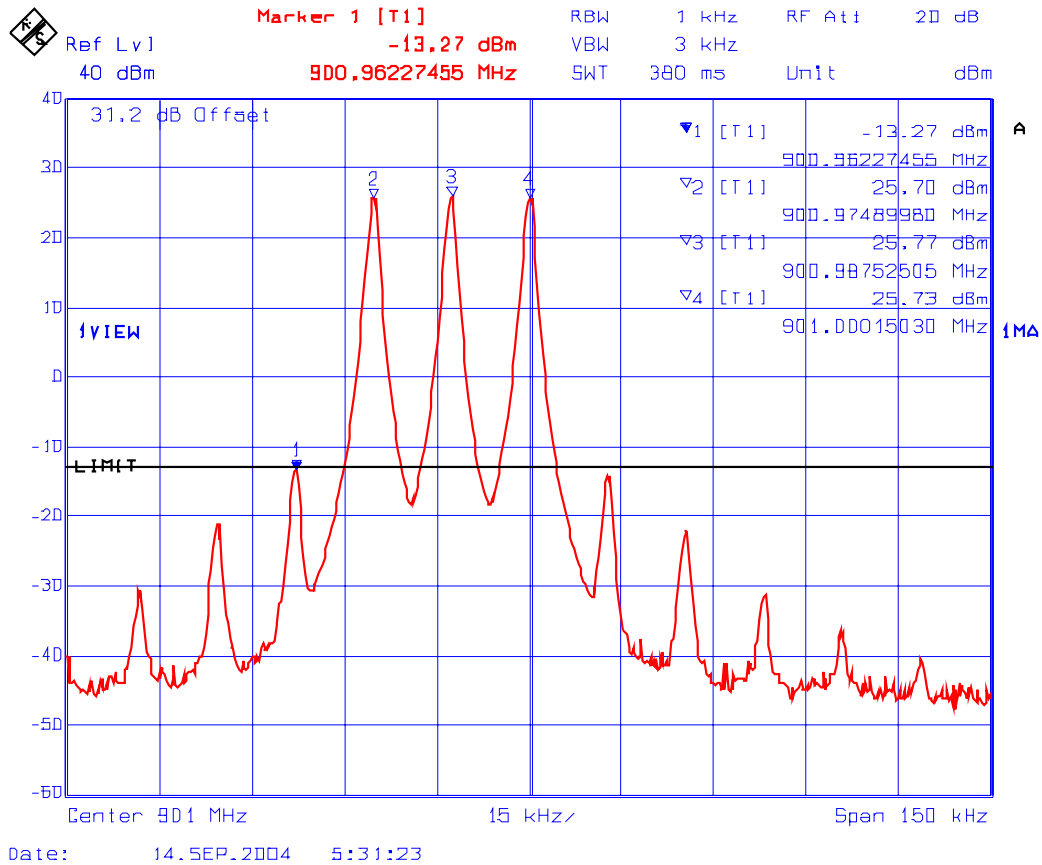

6.5.5.3. INTERMODULATION IN & PEAK POWERS IN 935-940 MHz BAND – NO MODULATION

Frequency (MHz)	Number of In/Out Channels	Modulation	Maximum RF Input (conducted) (dBm)	Maximum RF Output (conducted) (dBm)	Maximum Antenna Gain allowed (dB)	Maximum ERP Measured (dBm)	Manufacturer's Maximum RF Output Rating (conducted) (dBm)
935	1	unmodulated	0	35.0	0	34.9	35
935.0 935.0125	2	unmodulated	-52.2	31.4	0	31.4	35
935.0 935.0125 935.0250	3	unmodulated	-55.7	28.1	0	28.0	35
940	1	unmodulated	0	35.2	0	35.2	35
939.9875 940.0	2	unmodulated	-52.1	31.3	0	31.3	35
939.975 939.9875 940.0	3	unmodulated	-55.4	28.6	0	28.6	35

Refer to Plots # 7-12 for Intermodulation in the 935-940 MHz band.

PLOT # 7 Intermodulation with 1 RF signal input/output in 935-940 MHz Band
Fc: 935 MHz
RF Input: 0 dBm

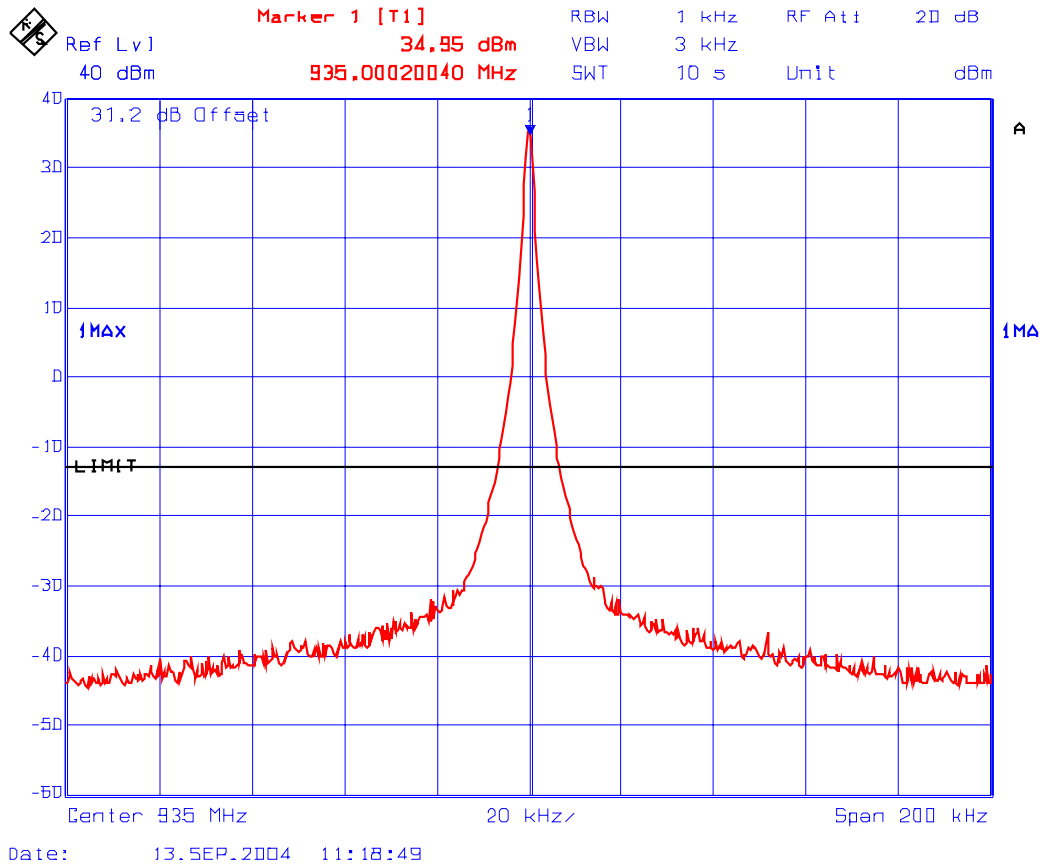

ULTRATECH GROUP OF LABS

3000 Bristol Circle, Oakville, Ontario, Canada L6H 6G4
Tel. #: 905-829-1570, Fax. #: 905-829-8050, Email: vic@ultratech-labs.com, Website: <http://www.ultratech-labs.com>

File #: TXRX-009FCC90

October 14, 2004

All test results contained in this engineering test report are traceable to National Institute of Standards and Technology (NIST)

PLOT # 8 Intermodulation with 2 RF signal inputs/outputs in 935-940 MHz Band
Fc: 935 MHz & Fc + 12.5 kHz
RF Input: (1) -52.34 dBm, (2) -52.24 dBm

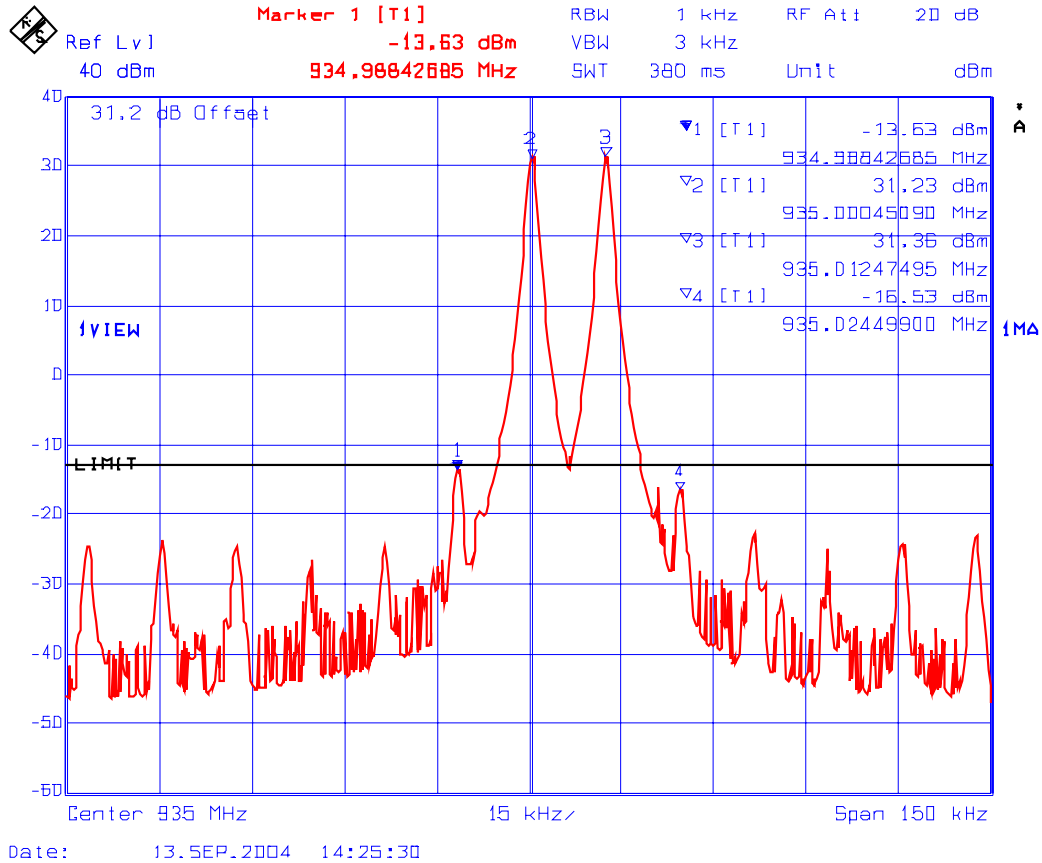

PLOT # 9 Intermodulation with 3 RF signal inputs/outputs in 935-940 MHz Band
Fc: 935 MHz, Fc + 12.5 kHz & Fc + 25 kHz
RF Input: (1) -55.74 dBm, (2) -55.83 dBm, (3) -55.81 dBm

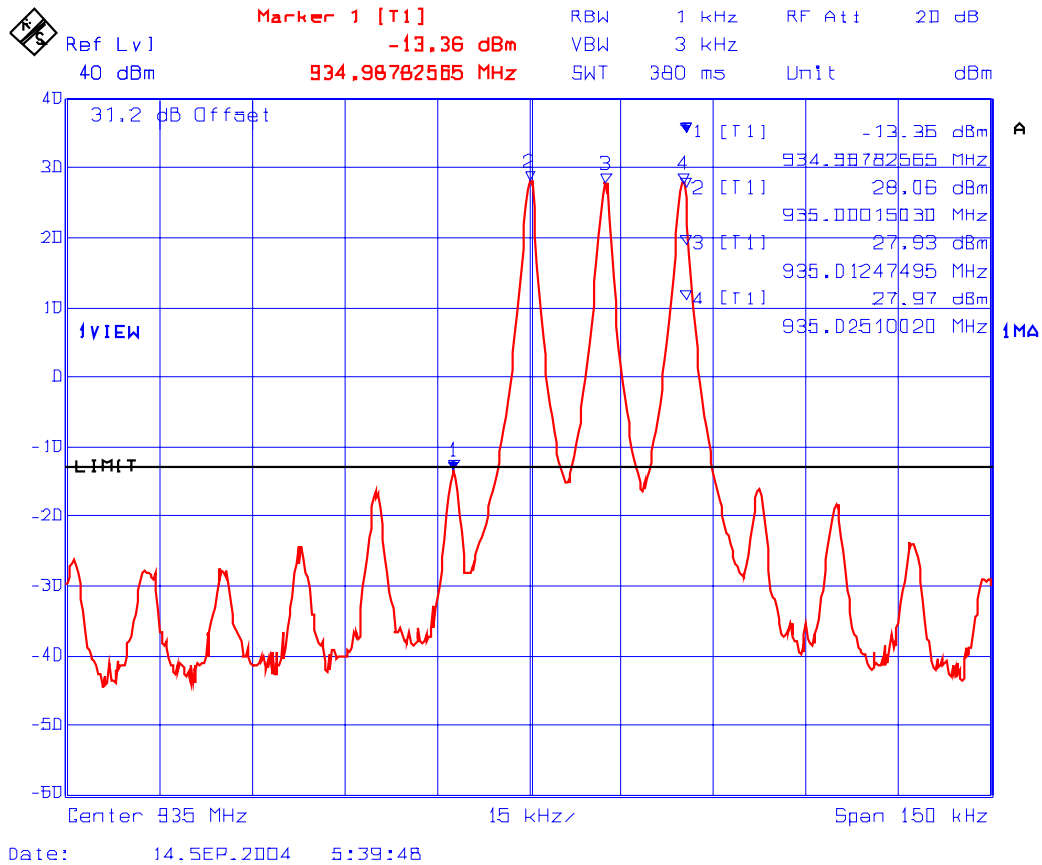

ULTRATECH GROUP OF LABS

3000 Bristol Circle, Oakville, Ontario, Canada L6H 6G4
Tel. #: 905-829-1570, Fax. #: 905-829-8050, Email: vic@ultratech-labs.com, Website: <http://www.ultratech-labs.com>

File #: TXRX-009FCC90

October 14, 2004

All test results contained in this engineering test report are traceable to National Institute of Standards and Technology (NIST)

PLOT # 10 **Intermodulation with 1 RF signal input/output in 935-940 MHz Band**
Fc: 940 MHz
RF Input: 0 dBm

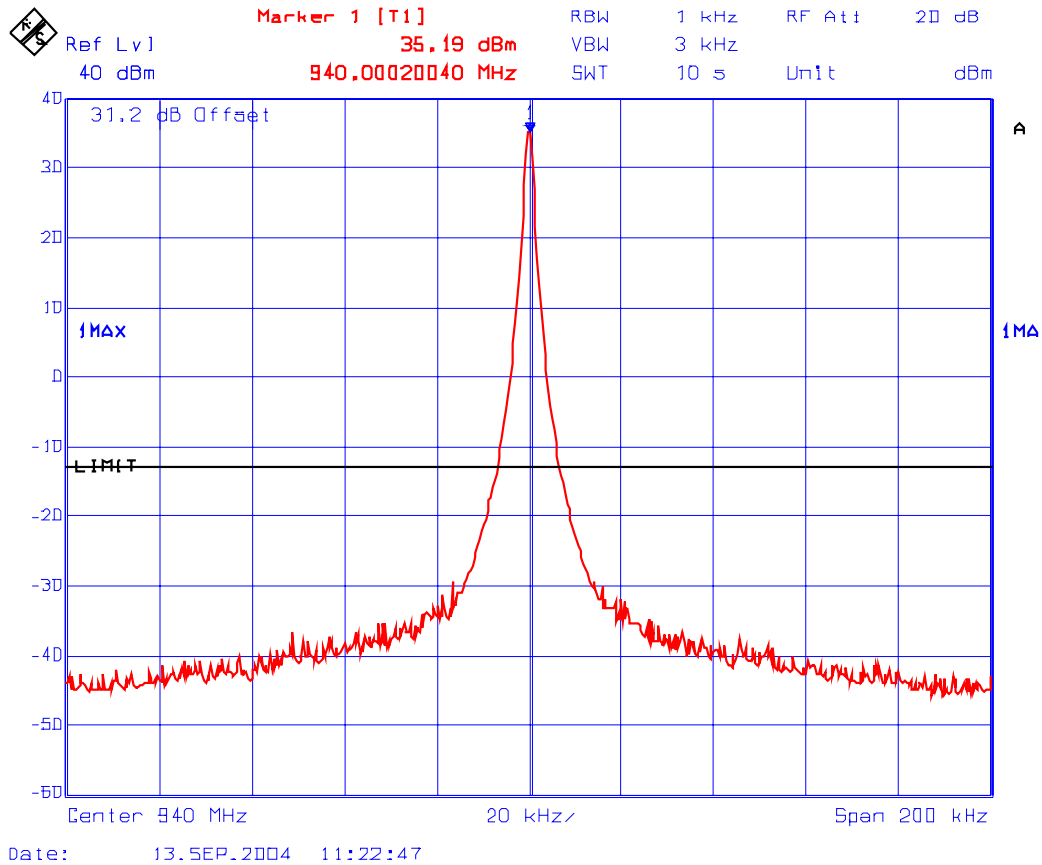

ULTRATECH GROUP OF LABS

3000 Bristol Circle, Oakville, Ontario, Canada L6H 6G4
Tel. #: 905-829-1570, Fax. #: 905-829-8050, Email: vic@ultratech-labs.com, Website: <http://www.ultratech-labs.com>

File #: TXRX-009FCC90

October 14, 2004

All test results contained in this engineering test report are traceable to National Institute of Standards and Technology (NIST)

PLOT # 12 Intermodulation with 3 RF signal inputs/outputs in 935-940 MHz Band
Fc: 940 MHz, Fc -12.5 kHz & Fc - 25 kHz
RF Input: (1) -55.61 dBm, (2) -55.67 dBm, (3) -55.42 dBm

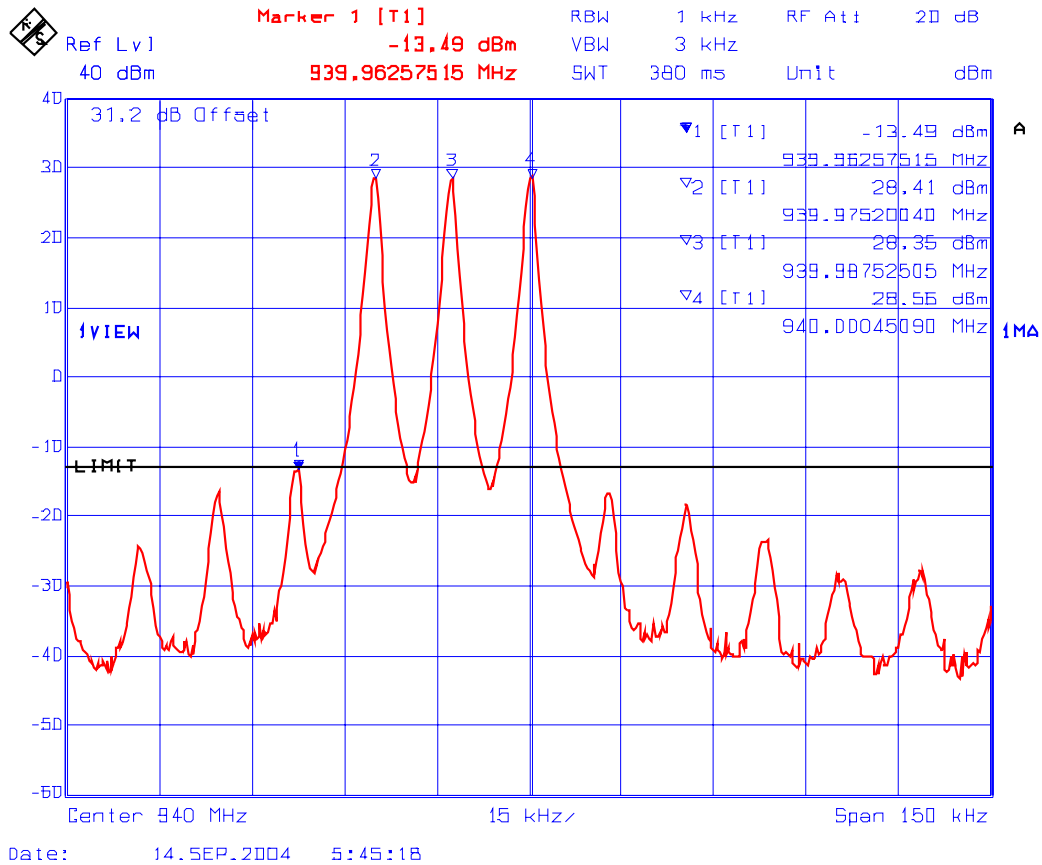

6.6. RF EXPOSURE REQUIREMENTS [§§ 1.1310 & 2.1091]

6.6.1. Limits

FCC 1.1310:- The criteria listed in the following table shall be used to evaluate the environmental impact of human exposure to radio-frequency (RF) radiation as specified in 1.1307(b).

TABLE 1—LIMITS FOR MAXIMUM PERMISSIBLE EXPOSURE (MPE)

Frequency range (MHz)	Electric field strength (V/m)	Magnetic field strength (A/m)	Power density (mW/cm ²)	Averaging time (minutes)
(A) Limits for Occupational/Controlled Exposures				
0.3–3.0	614	1.63	*(100)	6
3.0–30	1842/f	4.89/f	*(900/f ²)	6
30–300	61.4	0.163	1.0	6
300–1500	f/300	6
1500–100,000	5	6
(B) Limits for General Population/Uncontrolled Exposure				
0.3–1.34	614	1.63	*(100)	30
1.34–30	824/f	2.19/f	*(180/f ²)	30
30–300	27.5	0.073	0.2	30
300–1500	f/1500	30
1500–100,000	1.0	30

f = frequency in MHz

* = Plane-wave equivalent power density

NOTE 1 TO TABLE 1: Occupational/controlled limits apply in situations in which persons are exposed as a consequence of their employment provided those persons are fully aware of the potential for exposure and can exercise control over their exposure. Limits for occupational/controlled exposure also apply in situations when an individual is transient through a location where occupational/controlled limits apply provided he or she is made aware of the potential for exposure.

NOTE 2 TO TABLE 1: General population/uncontrolled exposures apply in situations in which the general public may be exposed, or in which persons that are exposed as a consequence of their employment may not be fully aware of the potential for exposure or can not exercise control over their exposure.

6.6.2. Method of Measurements

Refer to FCC @ 1.1310 and 2.1091

- In order to demonstrate compliance with MPE requirements (see Section 2.1091), the following information is typically needed:
 - (1) Calculation that estimates the minimum separation distance (20 cm or more) between an antenna and persons required to satisfy power density limits defined for free space.
 - (2) Antenna installation and device operating instructions for installers (professional/unskilled users), and the parties responsible for ensuring compliance with the RF exposure requirement.
 - (3) Any caution statements and/or warning labels that are necessary in order to comply with the exposure limits.
 - (4) Any other RF exposure related issues that may affect MPE compliance.

Calculation Method of RF Safety Distance:

$$S = PG/4\pi r^2 = EIRP/4\pi r^2$$

Where: P: power input to the antenna in mW
EIRP: Equivalent (effective) isotropic radiated power.
S: power density mW/cm²
G: numeric gain of antenna relative to isotropic radiator
r: distance to centre of radiation in cm

$$r = \sqrt{PG/4\pi S}$$

- For portable transmitters (see Section 2.1093), or devices designed to operate next to a person's body, compliance is determined with respect to the SAR limit (define in the body tissues) for near-field exposure conditions. If the maximum average output power, operating condition configurations and exposure conditions are comparable to those of existing cellular and PCS phones, SAR evaluation may be required in order to determine if such a device complies with SAR limit. When SAR evaluation data is not available, and the additional supporting information cannot assure compliance, the Commission may request that an SAR evaluation be performed, as provided for in Section 1.1307(d).

6.6.3. Test Data

Evaluation of RF Exposure Compliance Requirements	
RF Exposure Requirements	Compliance with FCC Rules
Minimum calculated separation distance between antenna and persons required: *Indoor Antenna: 28.2 cm *Outdoor Antenna: 89.1 cm	Manufacturer' instruction for separation distance between antenna and persons required: Indoor Antenna: 30 cm Outdoor Antenna: 1 Meter
Antenna installation and device operating instructions for installers (professional/unskilled users), and the parties responsible for ensuring compliance with the RF exposure requirement	Please refer to User's Manual for details.
Caution statements and/or warning labels that are necessary in order to comply with the exposure limits	Please refer to User's Manual for RF Exposure Information.
Any other RF exposure related issues that may affect MPE compliance	None.

* The minimum separation distance between the antenna and bodies of users are calculated using the following formula:

$$\text{RF EXPOSURE DISTANCE LIMITS: } r = (PG/4\pi S)^{1/2} = (EIRP/4\pi S)^{1/2}$$

Indoor antenna (Maximum antenna gain of 0 dB):

$$S = 896/1500 \text{ mW/cm}^2$$

$$EIRP = 37.75 \text{ dBm} = 5957 \text{ mW (Max. EIRP)}$$

$$r = (EIRP/4\pi S)^{1/2} = (5957 / 4\pi(896/1500))^{1/2} = 28.2 \text{ cm}$$

Outdoor antenna (Maximum antenna gain of 10 dB):

$$S = 896/1500 \text{ mW/cm}^2$$

$$EIRP = 47.75 \text{ dBm} = 59566 \text{ mW (Max. EIRP)}$$

$$r = (EIRP/4\pi S)^{1/2} = (59566 / 4\pi(896/1500))^{1/2} = 89.1 \text{ cm}$$

Note: The calculation is based on the lowest frequency (896 MHz) and the highest conducted power (35.6 dBm) for the worst case.

6.7. OCCUPIED BANDWIDTH AND EMISSION MASK [§§ 2.1049, 90.209 & 90.210]

6.7.1. Limits

Emissions shall be attenuated below the mean output power of the transmitter as follows:

Frequency Band (MHz)	Maximum Authorized BW (kHz)	Channel Spacing (kHz)	FCC Applicable Mask @ FCC 90.210
896-901/935-940	13.6	12.5	MASK I (Voice) & MASK J (Data)

6.7.2. Method of Measurements

Refer to ULTRATECH Test Procedures, File # ULTR P001-2004 and Exhibit 8 of this report for measurement details.

6.7.3. Test Equipment List

Test Instruments	Manufacturer	Model No.	Serial No.	Frequency Range
Spectrum Analyzer	Rohde & Schwarz	FSEK20/B4/B21	834157/005	9 kHz – 40 GHz
Function Generator	Stanford Research Systems	DS345	34591	1Hz -30.2 MHz
Voice Guard Digital Speech Encryption	General Electric	9600-SW	9614517	--
Attenuator	Weinschel Corp	48-30-34	BM5354	DC - 18 GHz

6.7.4. Test Arrangement

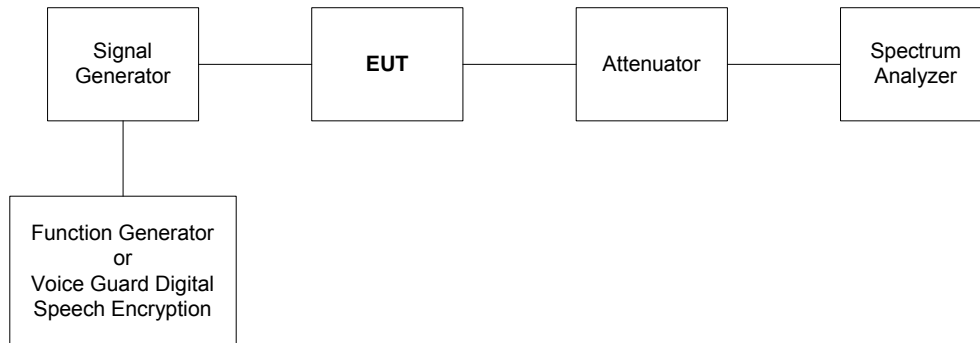

6.7.5. Test Data

6.7.5.1. 20 dB Bandwidth and Gain of the Amplifier

See the following plots for 20 dB passband gains of 896-901 MHz band (Plot # 13) and 935-940 MHz band (Plot # 14):

PLOT # 13 20 dB BW of the 896-901 MHz Passband Gain
RF Input: 0 dBm. Tracking from 850-950 MHz
Max Gain: 38.12 dB

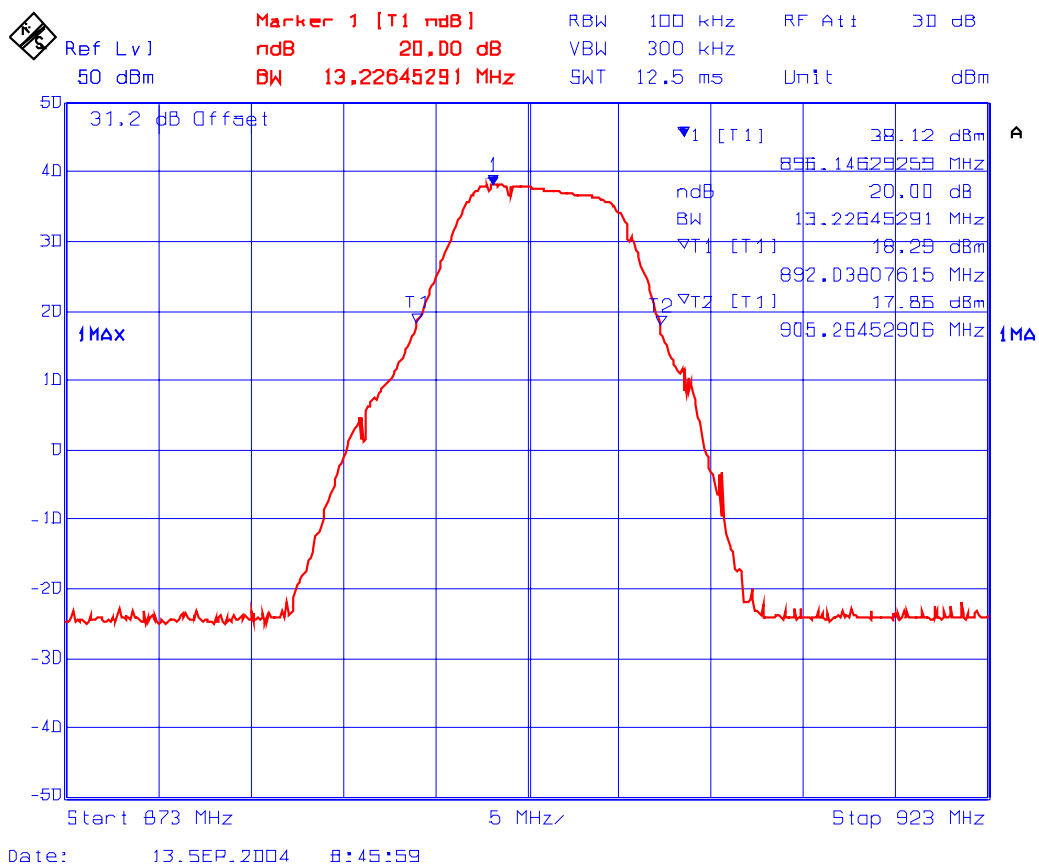

PLOT # 14 20 dB BW of the 935-940 MHz Passband Gain
RF Input: 0 dBm. Tracking from 900-1000 MHz
Max Gain: 41.59 dB

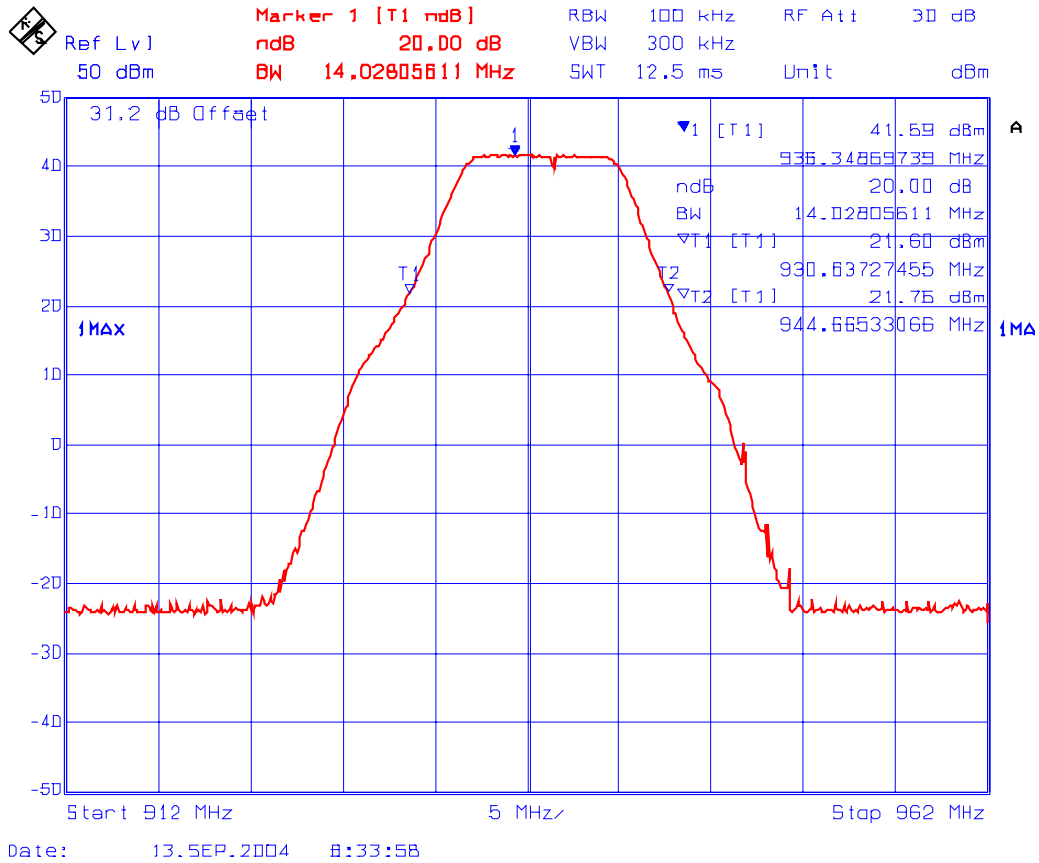

ULTRATECH GROUP OF LABS

3000 Bristol Circle, Oakville, Ontario, Canada L6H 6G4
 Tel. #: 905-829-1570, Fax. #: 905-829-8050, Email: vic@ultratech-labs.com, Website: <http://www.ultratech-labs.com>

File #: TXRX-009FCC90

October 14, 2004

All test results contained in this engineering test report are traceable to National Institute of Standards and Technology (NIST)

6.7.5.2. 99% Occupied Bandwidth Measurements

Remark: 99% OBW of the RF input and RF output signals were measured for comparison.

6.7.5.2.1. 896-901 MHz Band

EUT's Subband (MHz)	Frequency (MHz)	RF IN Measured 99% OBW (kHz)	RF OUT Measured 99% OBW (kHz)
Modulation: FM with 2.5 kHz sine wave signal			
896 - 901	896	10.6	10.6
	901	10.5	10.6
Modulation: FM with an external 9600 b/s random data source			
896 - 901	896	11.7	11.8
	901	11.7	11.8

See the following plots (# 15-22) for 99% occupied bandwidth measurements in 896-901 MHz band.

PLOT # 15 99% Occupied Bandwidth – RF Input Signal
Frequency: 896 MHz, 12.5 kHz Channel Spacing
Modulation: FM modulation with 2.5 kHz sine wave signal

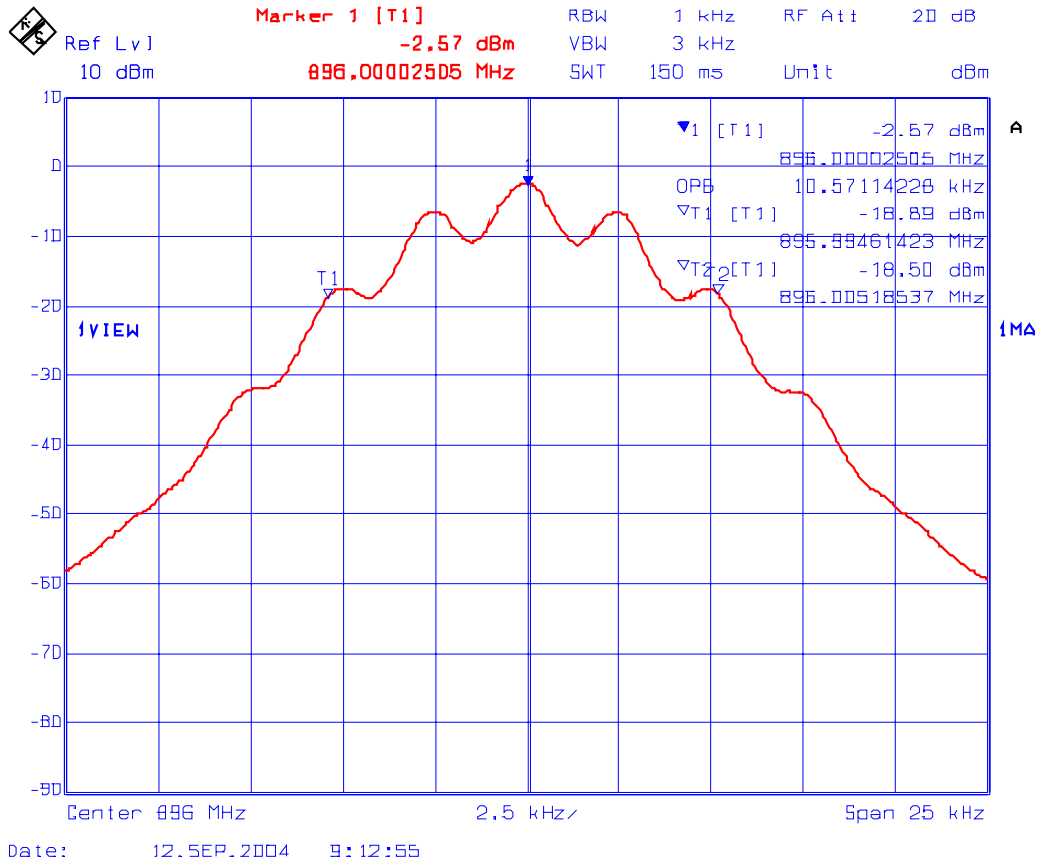

ULTRATECH GROUP OF LABS

3000 Bristol Circle, Oakville, Ontario, Canada L6H 6G4
 Tel. #: 905-829-1570, Fax. #: 905-829-8050, Email: vic@ultratech-labs.com, Website: <http://www.ultratech-labs.com>

File #: TXRX-009FCC90

October 14, 2004

All test results contained in this engineering test report are traceable to National Institute of Standards and Technology (NIST)

PLOT # 16 99% Occupied Bandwidth – RF Output Signal
Frequency: 896 MHz, 12.5 kHz Channel Spacing
Modulation: FM modulation with 2.5 kHz Sine wave signal

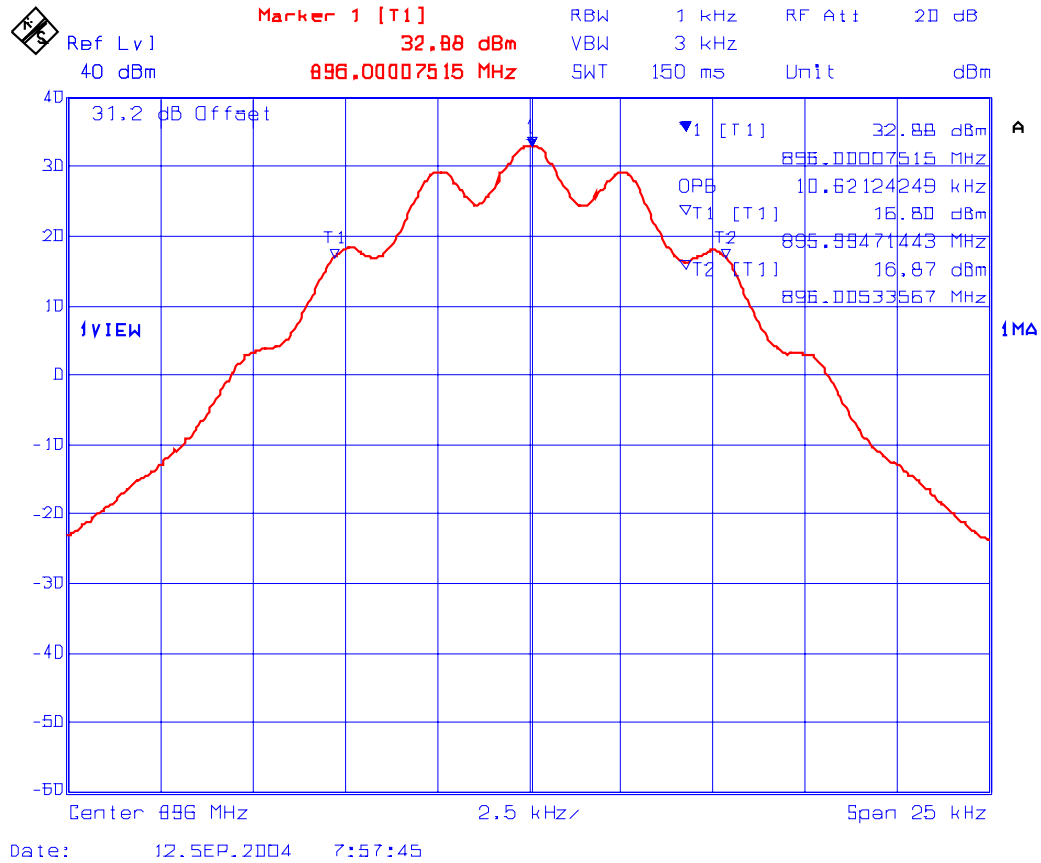

PLOT # 17 **99% Occupied Bandwidth – RF Input**
Frequency: 901 MHz, 12.5 kHz Channel Spacing
Modulation: FM modulation with 2.5 kHz sine wave signal

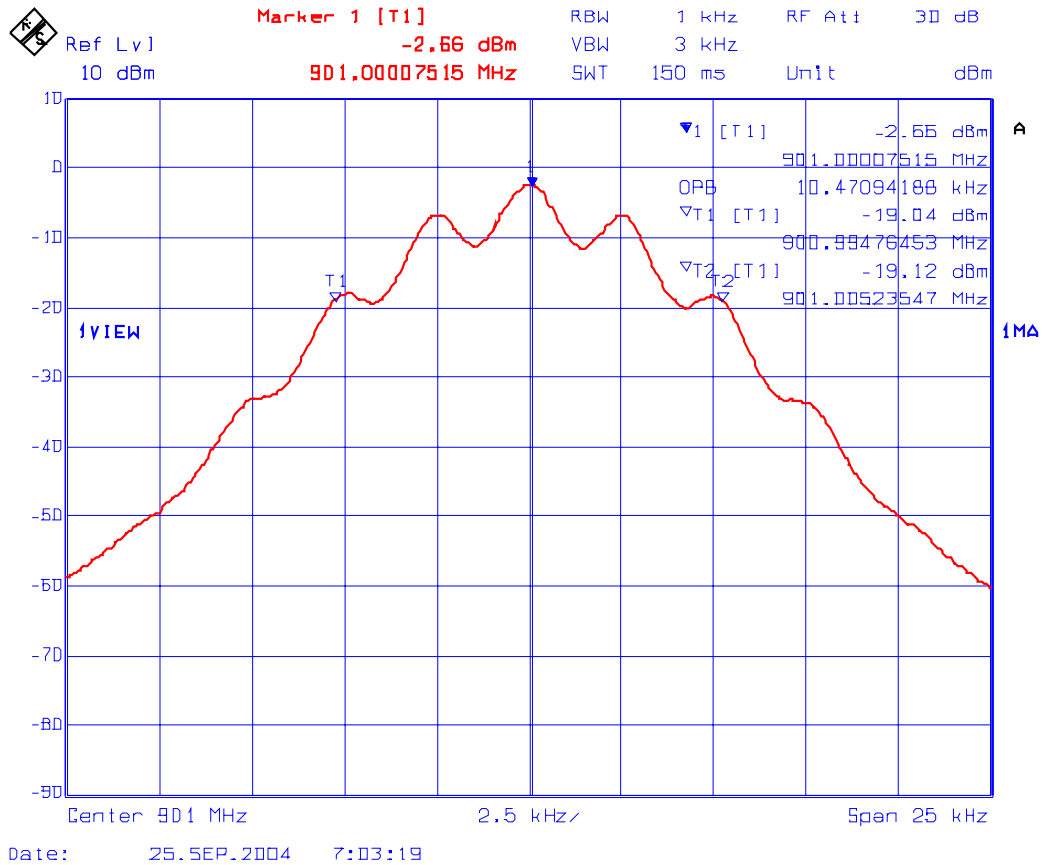

ULTRATECH GROUP OF LABS

3000 Bristol Circle, Oakville, Ontario, Canada L6H 6G4
Tel. #: 905-829-1570, Fax. #: 905-829-8050, Email: vic@ultratech-labs.com, Website: <http://www.ultratech-labs.com>

File #: TXRX-009FCC90

October 14, 2004

All test results contained in this engineering test report are traceable to National Institute of Standards and Technology (NIST)

PLOT # 18 **99% Occupied Bandwidth– RF Output**
Frequency: 901 MHz, 12.5 kHz Channel Spacing
Modulation: FM modulation with 2.5 kHz sine wave signal

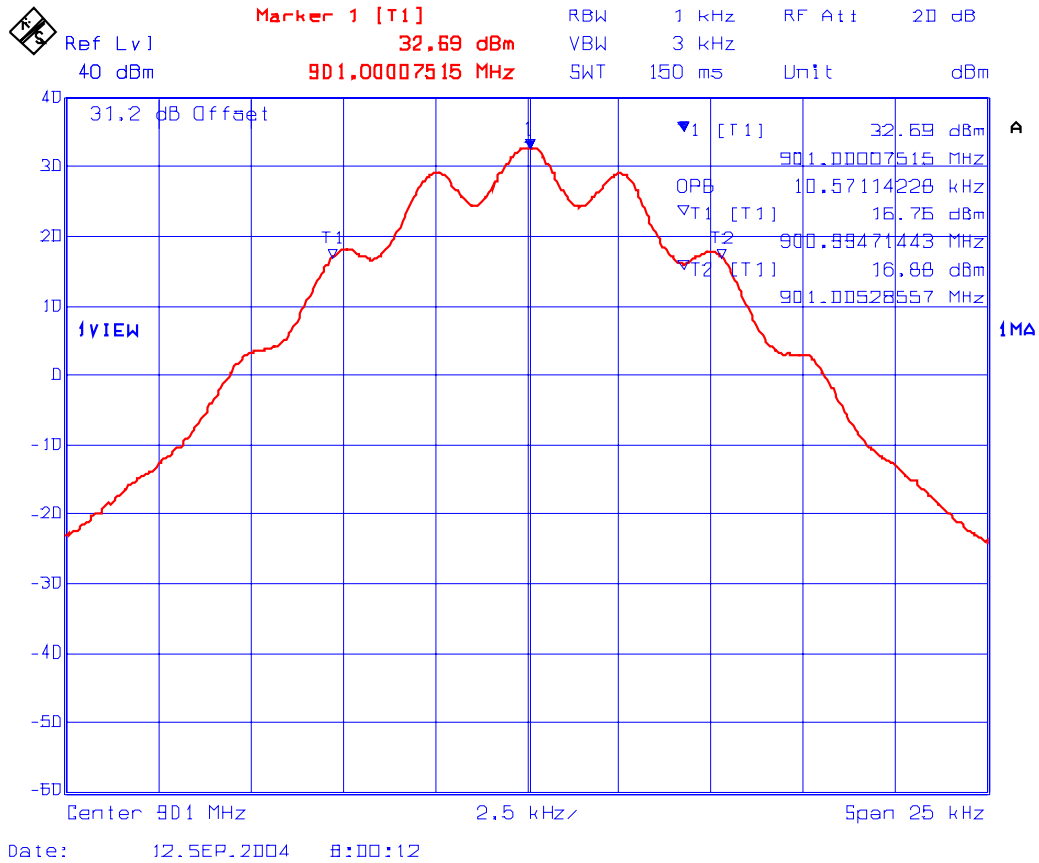

ULTRATECH GROUP OF LABS

3000 Bristol Circle, Oakville, Ontario, Canada L6H 6G4
 Tel. #: 905-829-1570, Fax. #: 905-829-8050, Email: vic@ultratech-labs.com, Website: <http://www.ultratech-labs.com>

File #: TXRX-009FCC90

October 14, 2004

All test results contained in this engineering test report are traceable to National Institute of Standards and Technology (NIST)

PLOT # 19 **99% Occupied Bandwidth- RF Input**
Frequency: 896 MHz, 12.5 kHz Channel Spacing
Modulation: FM modulation with an external 9600 b/s random data source

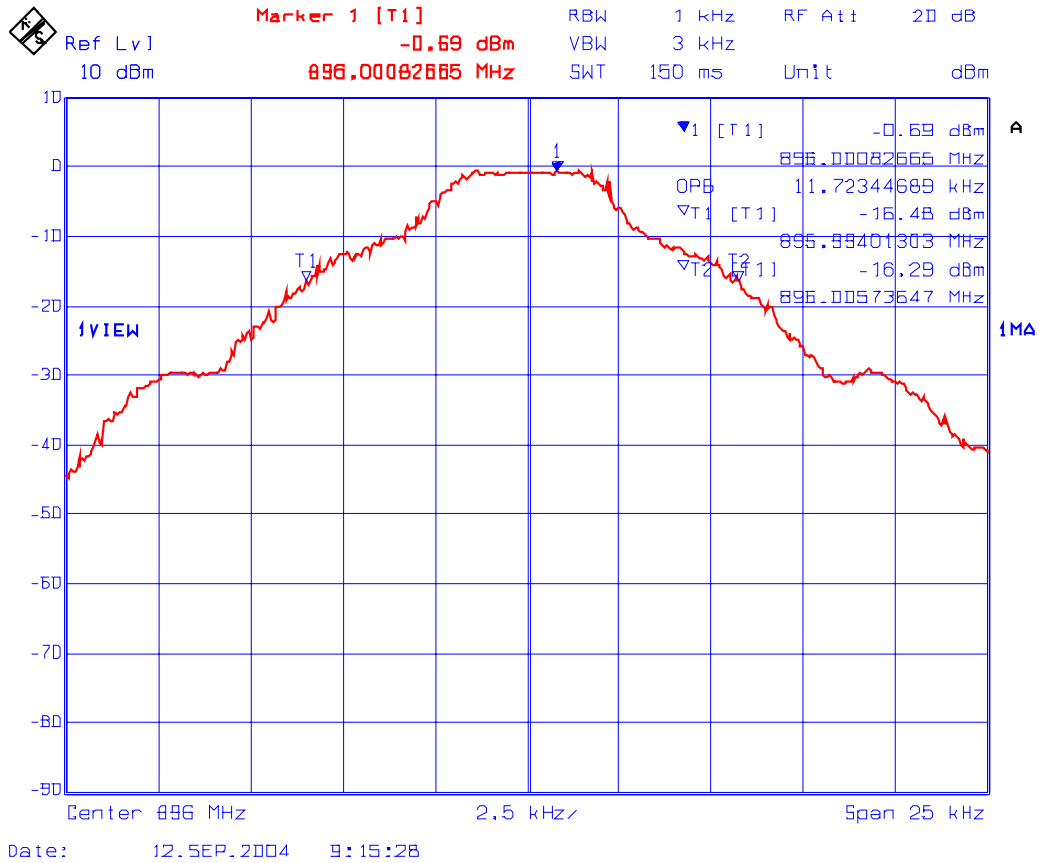

ULTRATECH GROUP OF LABS

3000 Bristol Circle, Oakville, Ontario, Canada L6H 6G4
 Tel. #: 905-829-1570, Fax. #: 905-829-8050, Email: vic@ultratech-labs.com, Website: <http://www.ultratech-labs.com>

File #: TXRX-009FCC90

October 14, 2004

All test results contained in this engineering test report are traceable to National Institute of Standards and Technology (NIST)

PLOT # 20 99% Occupied Bandwidth- RF Output
Frequency: 896 MHz, 12.5 kHz Channel Spacing
Modulation: FM modulation with an external 9600 b/s random data source

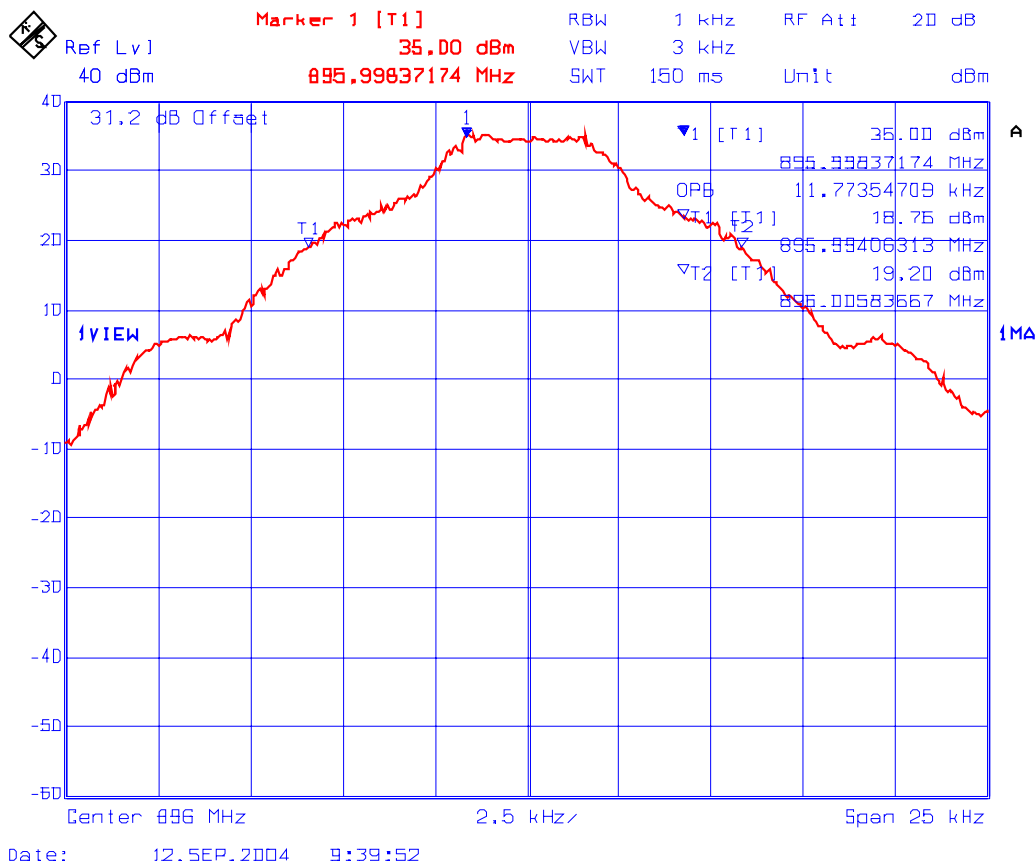

ULTRATECH GROUP OF LABS

3000 Bristol Circle, Oakville, Ontario, Canada L6H 6G4
 Tel. #: 905-829-1570, Fax. #: 905-829-8050, Email: vic@ultratech-labs.com, Website: <http://www.ultratech-labs.com>

File #: TXRX-009FCC90

October 14, 2004

All test results contained in this engineering test report are traceable to National Institute of Standards and Technology (NIST)

PLOT # 21 **99% Occupied Bandwidth-RF Input**
Frequency: 901 MHz, 12.5 kHz Channel Spacing
Modulation: FM modulation with an external 9600 b/s random data source

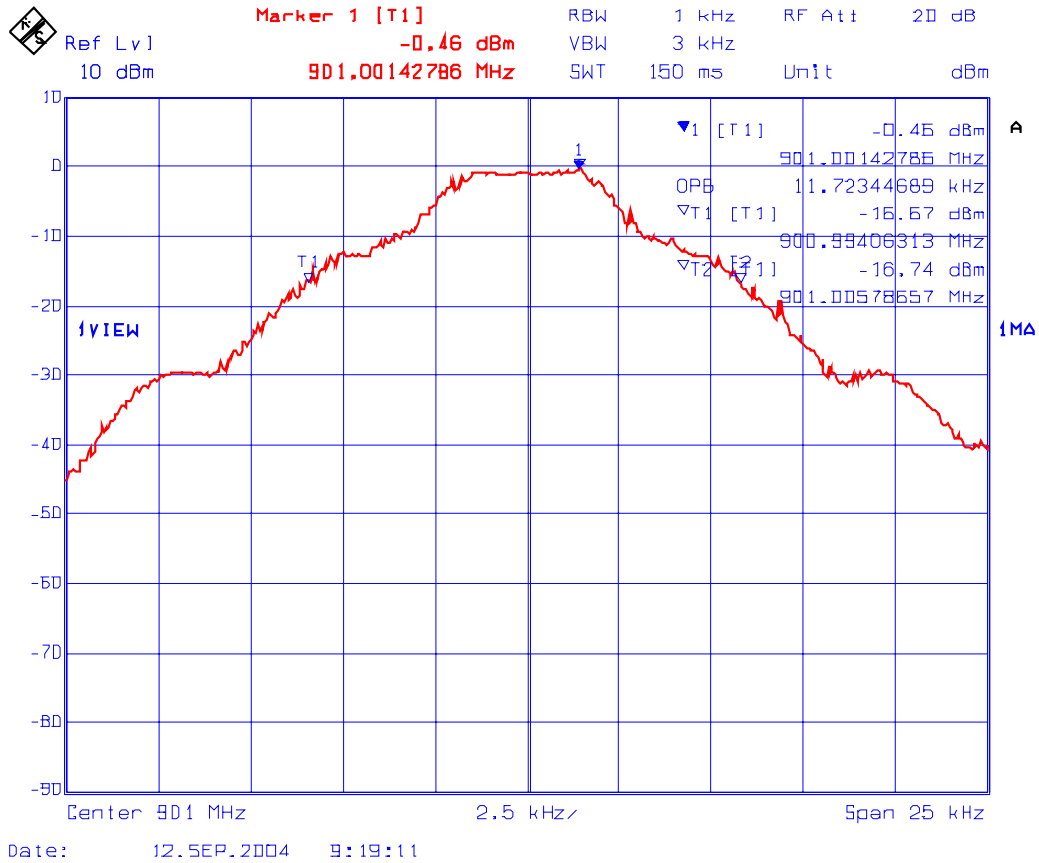

ULTRATECH GROUP OF LABS

3000 Bristol Circle, Oakville, Ontario, Canada L6H 6G4
 Tel. #: 905-829-1570, Fax. #: 905-829-8050, Email: vic@ultratech-labs.com, Website: <http://www.ultratech-labs.com>

File #: TXRX-009FCC90

October 14, 2004

All test results contained in this engineering test report are traceable to National Institute of Standards and Technology (NIST)

PLOT # 22 99% Occupied Bandwidth-RF Output
Frequency: 901 MHz, 12.5 kHz Channel Spacing
Modulation: FM modulation with an external 9600 b/s random data source

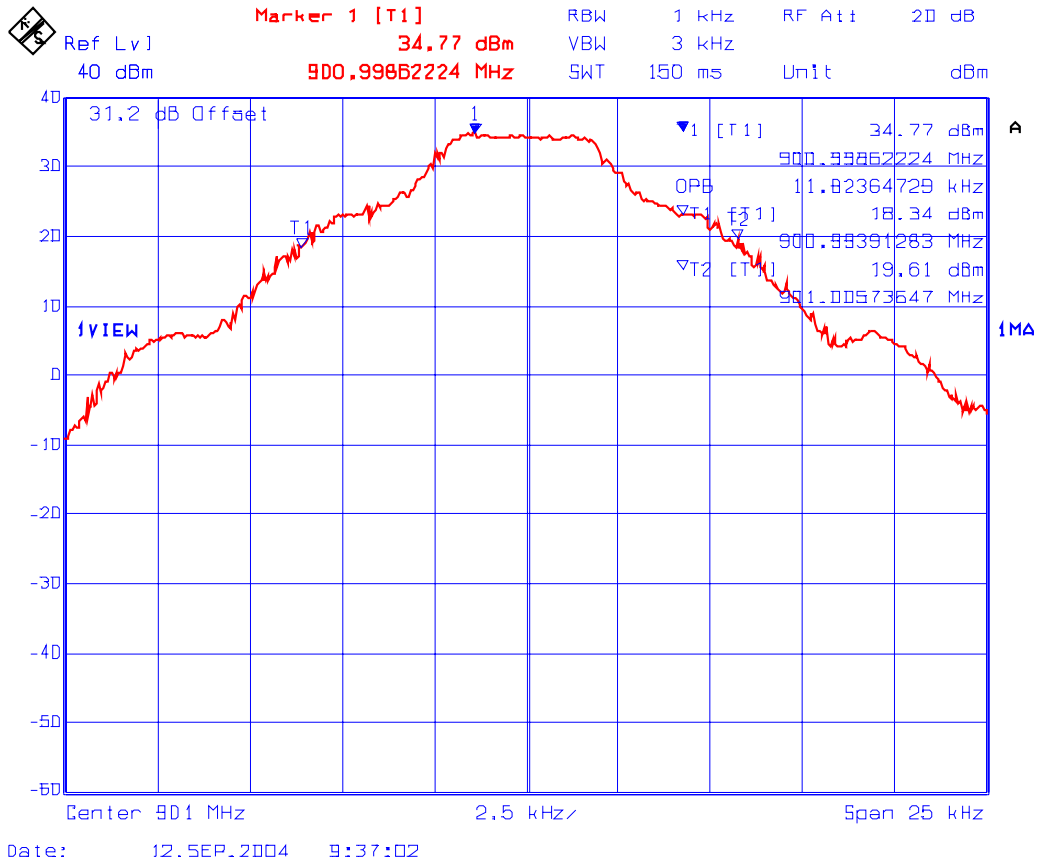

ULTRATECH GROUP OF LABS

3000 Bristol Circle, Oakville, Ontario, Canada L6H 6G4
 Tel. #: 905-829-1570, Fax. #: 905-829-8050, Email: vic@ultratech-labs.com, Website: <http://www.ultratech-labs.com>

File #: TXRX-009FCC90

October 14, 2004

All test results contained in this engineering test report are traceable to National Institute of Standards and Technology (NIST)

6.7.5.2.2. 935-940 MHz Band

EUT's Subband (MHz)	Frequency (MHz)	RF IN Measured 99% OBW (kHz)	RF OUT Measured 99% OBW (kHz)
Modulation: FM with 2.5 kHz sine wave signal			
935 - 940	935	10.6	10.6
	940	10.6	10.6
Modulation: FM with an external 9600 b/s random data source			
935 - 940	935	11.8	11.8
	940	11.8	11.7

See the following plots (# 23-30) for 99% occupied bandwidth measurements in 935-940 MHz band.

PLOT # 23 **99% Occupied Bandwidth-RF Input**
Frequency: 935 MHz, 12.5 kHz Channel Spacing
Modulation: FM Modulation with 2.5 kHz Sine Wave Signal

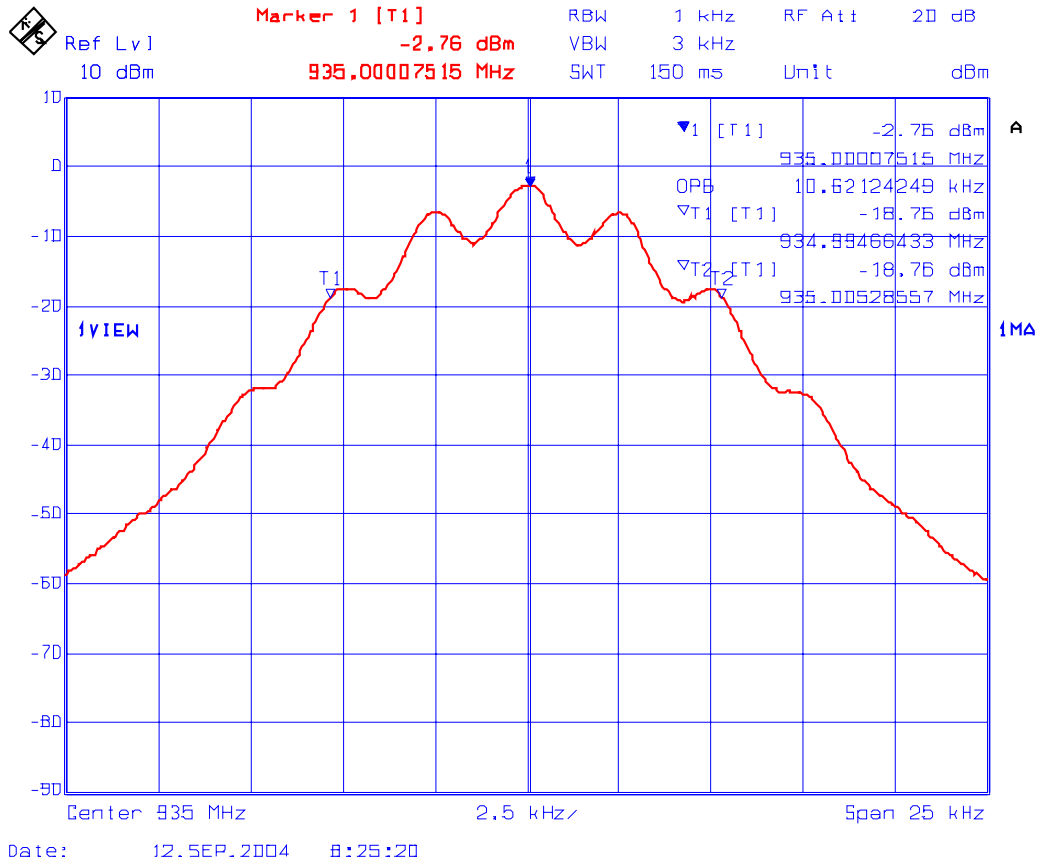

ULTRATECH GROUP OF LABS

3000 Bristol Circle, Oakville, Ontario, Canada L6H 6G4
 Tel. #: 905-829-1570, Fax. #: 905-829-8050, Email: vic@ultratech-labs.com, Website: <http://www.ultratech-labs.com>

File #: TXRX-009FCC90

October 14, 2004

All test results contained in this engineering test report are traceable to National Institute of Standards and Technology (NIST)

PLOT # 24 **99% Occupied Bandwidth - RF Output**
Frequency: 935 MHz, 12.5 kHz Channel Spacing
Modulation: FM modulation with 2.5 kHz Sine wave signal

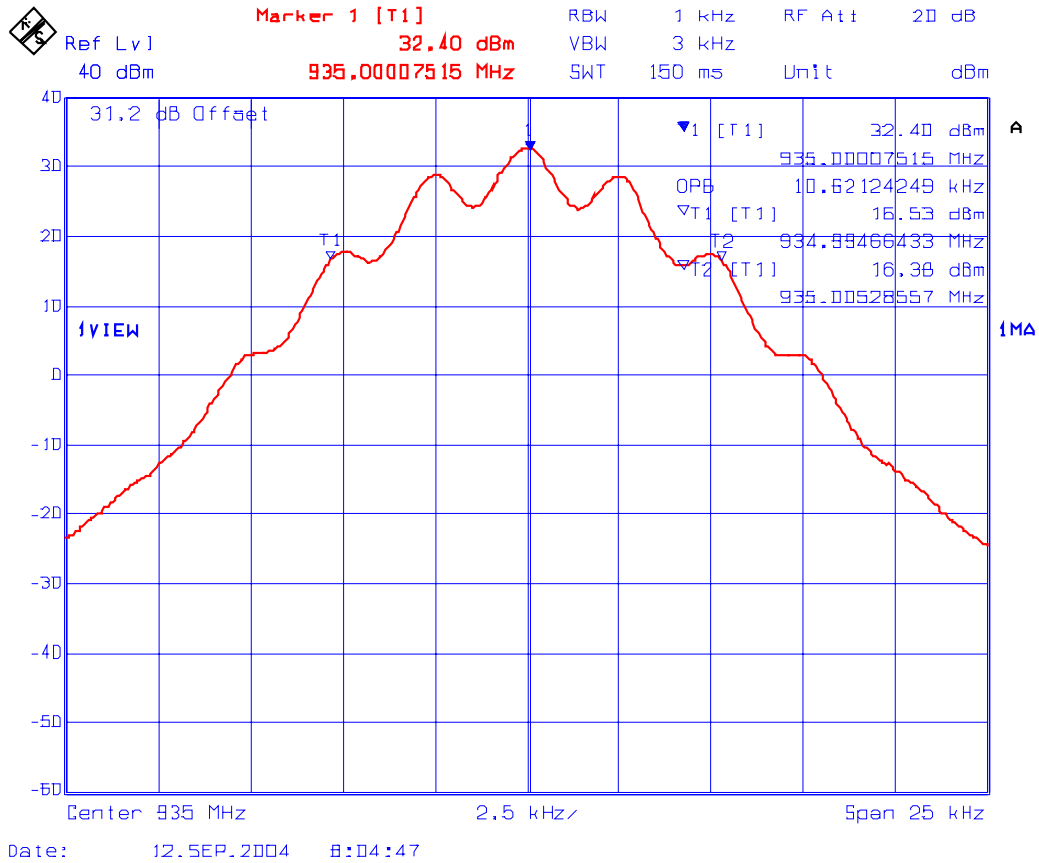

ULTRATECH GROUP OF LABS

3000 Bristol Circle, Oakville, Ontario, Canada L6H 6G4
 Tel. #: 905-829-1570, Fax. #: 905-829-8050, Email: vic@ultratech-labs.com, Website: <http://www.ultratech-labs.com>

File #: TXRX-009FCC90

October 14, 2004

All test results contained in this engineering test report are traceable to National Institute of Standards and Technology (NIST)

PLOT # 25 **99% Occupied Bandwidth - RF Input**
Frequency: 940 MHz, 12.5 kHz Channel Spacing
Modulation: FM modulation with 2.5 kHz Sine wave signal

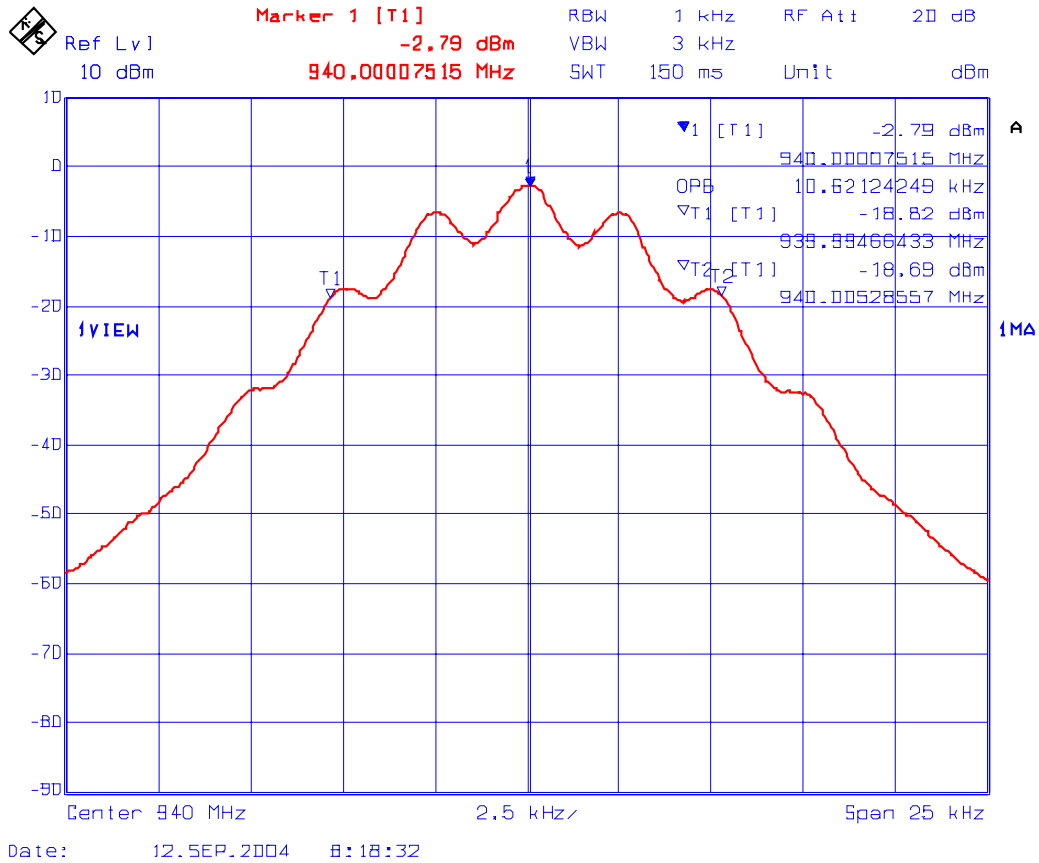

ULTRATECH GROUP OF LABS

3000 Bristol Circle, Oakville, Ontario, Canada L6H 6G4
 Tel. #: 905-829-1570, Fax. #: 905-829-8050, Email: vic@ultratech-labs.com, Website: <http://www.ultratech-labs.com>

File #: TXRX-009FCC90

October 14, 2004

All test results contained in this engineering test report are traceable to National Institute of Standards and Technology (NIST)

PLOT # 26 **99% Occupied Bandwidth - RF Output**
Frequency: 940 MHz, 12.5 kHz Channel Spacing
Modulation: FM modulation with 2.5 kHz Sine wave signal

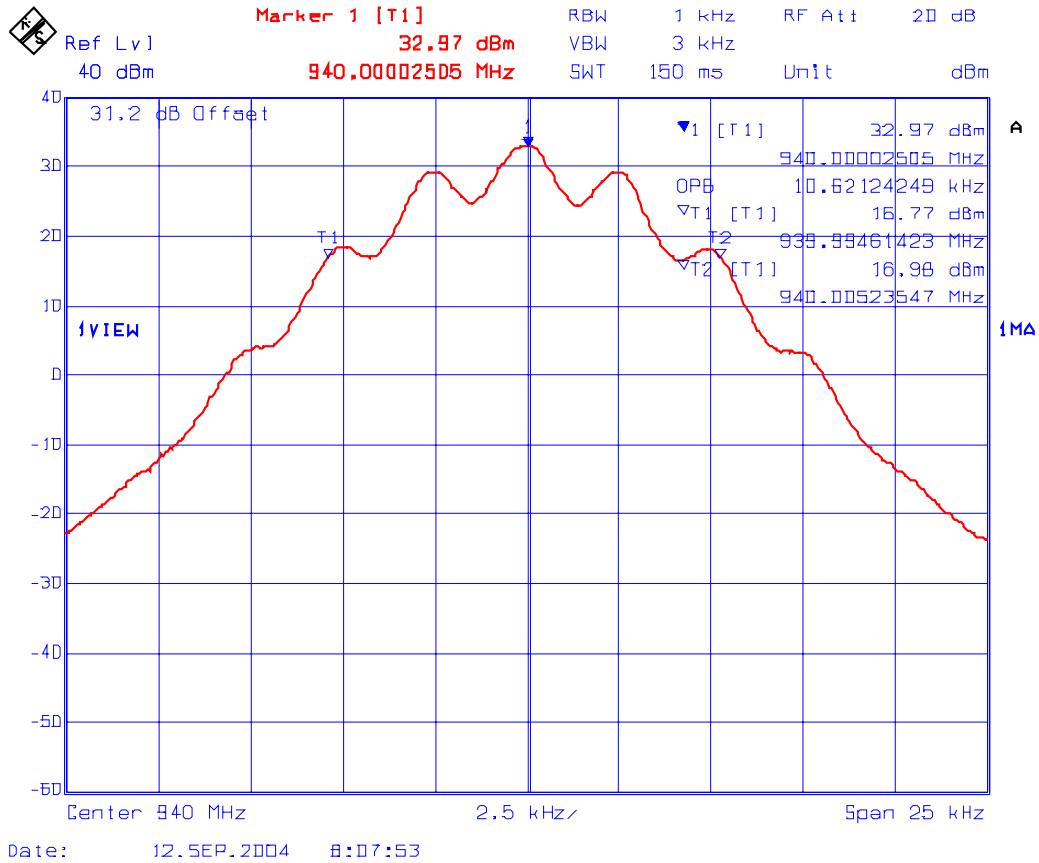

ULTRATECH GROUP OF LABS

3000 Bristol Circle, Oakville, Ontario, Canada L6H 6G4
 Tel. #: 905-829-1570, Fax. #: 905-829-8050, Email: vic@ultratech-labs.com, Website: <http://www.ultratech-labs.com>

File #: TXRX-009FCC90

October 14, 2004

All test results contained in this engineering test report are traceable to National Institute of Standards and Technology (NIST)

PLOT # 27 99% Occupied Bandwidth - RF Input
Frequency: 935 MHz, 12.5 kHz Channel Spacing
Modulation: FM modulation with an external 9600 b/s random data source

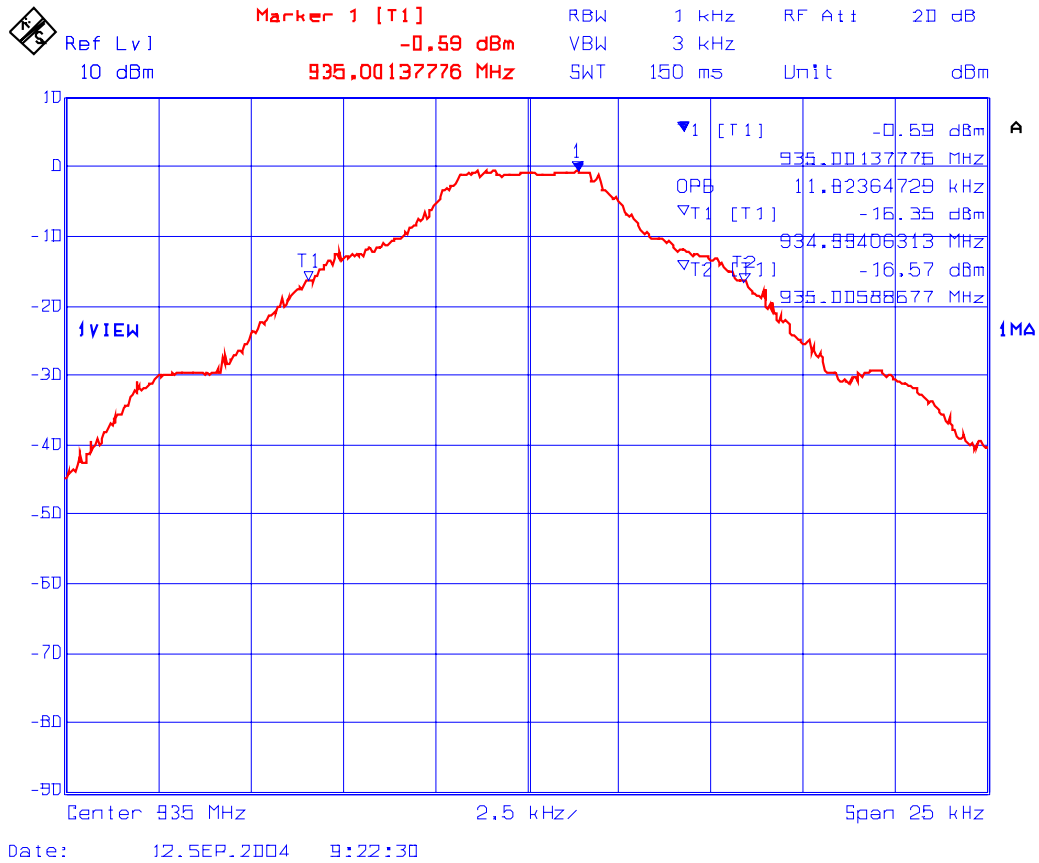

ULTRATECH GROUP OF LABS

3000 Bristol Circle, Oakville, Ontario, Canada L6H 6G4
 Tel. #: 905-829-1570, Fax. #: 905-829-8050, Email: vic@ultratech-labs.com, Website: <http://www.ultratech-labs.com>

File #: TXRX-009FCC90

October 14, 2004

All test results contained in this engineering test report are traceable to National Institute of Standards and Technology (NIST)

PLOT # 28 **99% Occupied Bandwidth - RF Output**
Frequency: 935 MHz, 12.5 kHz Channel Spacing
Modulation: FM modulation with an external 9600 b/s random data source

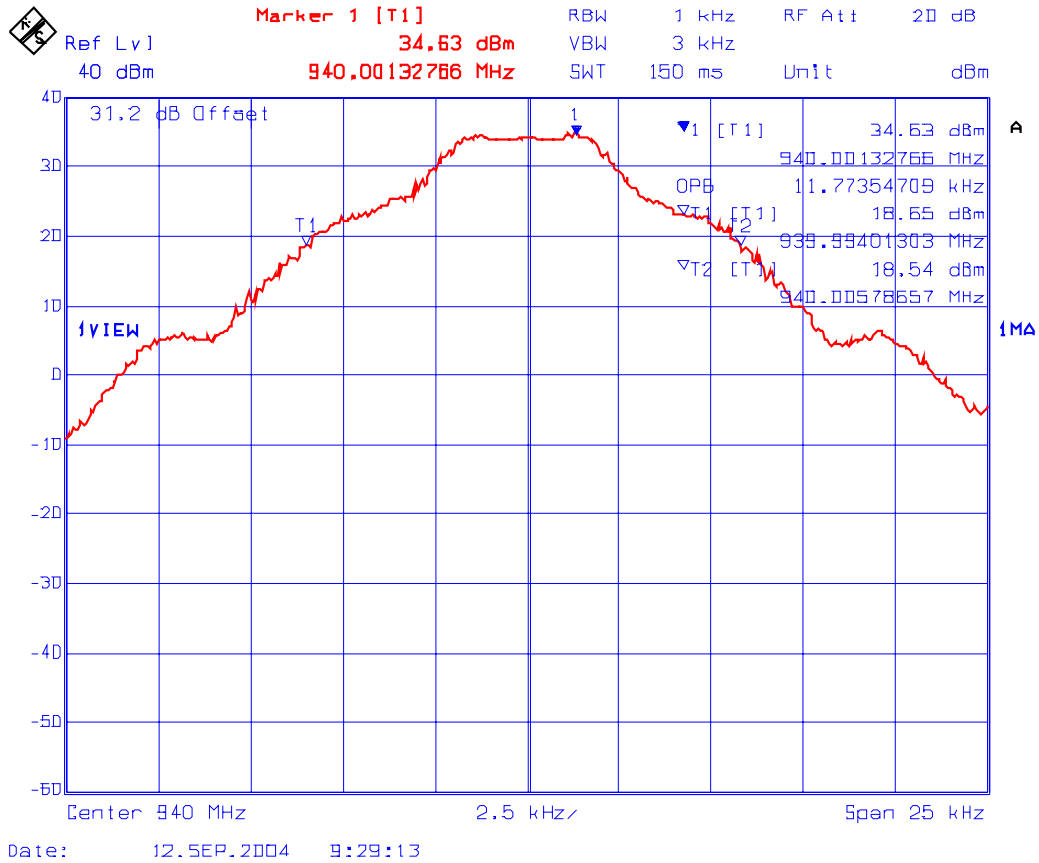

ULTRATECH GROUP OF LABS

3000 Bristol Circle, Oakville, Ontario, Canada L6H 6G4
 Tel. #: 905-829-1570, Fax. #: 905-829-8050, Email: vic@ultratech-labs.com, Website: <http://www.ultratech-labs.com>

File #: TXRX-009FCC90

October 14, 2004

All test results contained in this engineering test report are traceable to National Institute of Standards and Technology (NIST)

PLOT # 29 99% Occupied Bandwidth - RF Input
Frequency: 940 MHz, 12.5 kHz Channel Spacing
Modulation: FM modulation with an external 9600 b/s random data source

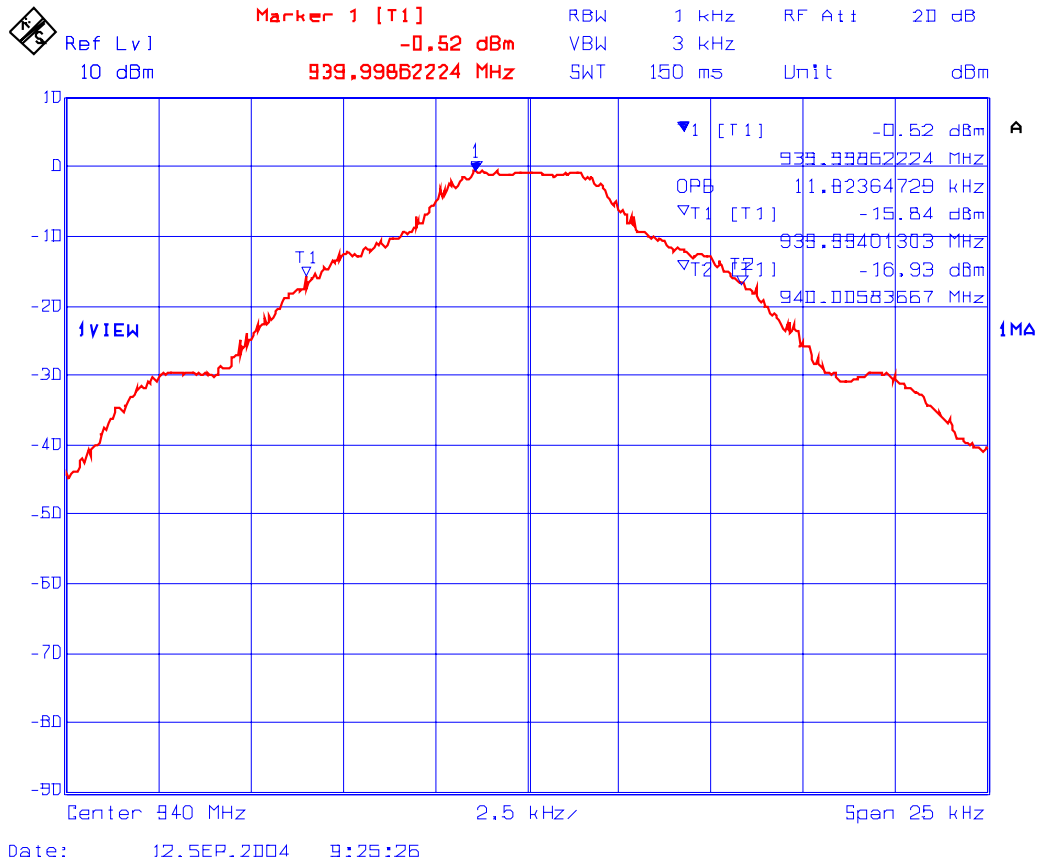

ULTRATECH GROUP OF LABS

3000 Bristol Circle, Oakville, Ontario, Canada L6H 6G4
 Tel. #: 905-829-1570, Fax. #: 905-829-8050, Email: vic@ultratech-labs.com, Website: <http://www.ultratech-labs.com>

File #: TXRX-009FCC90

October 14, 2004

All test results contained in this engineering test report are traceable to National Institute of Standards and Technology (NIST)

PLOT # 30 99% Occupied Bandwidth - RF Output
Frequency: 940 MHz, 12.5 kHz Channel Spacing
Modulation: FM modulation with an external 9600 b/s random data source

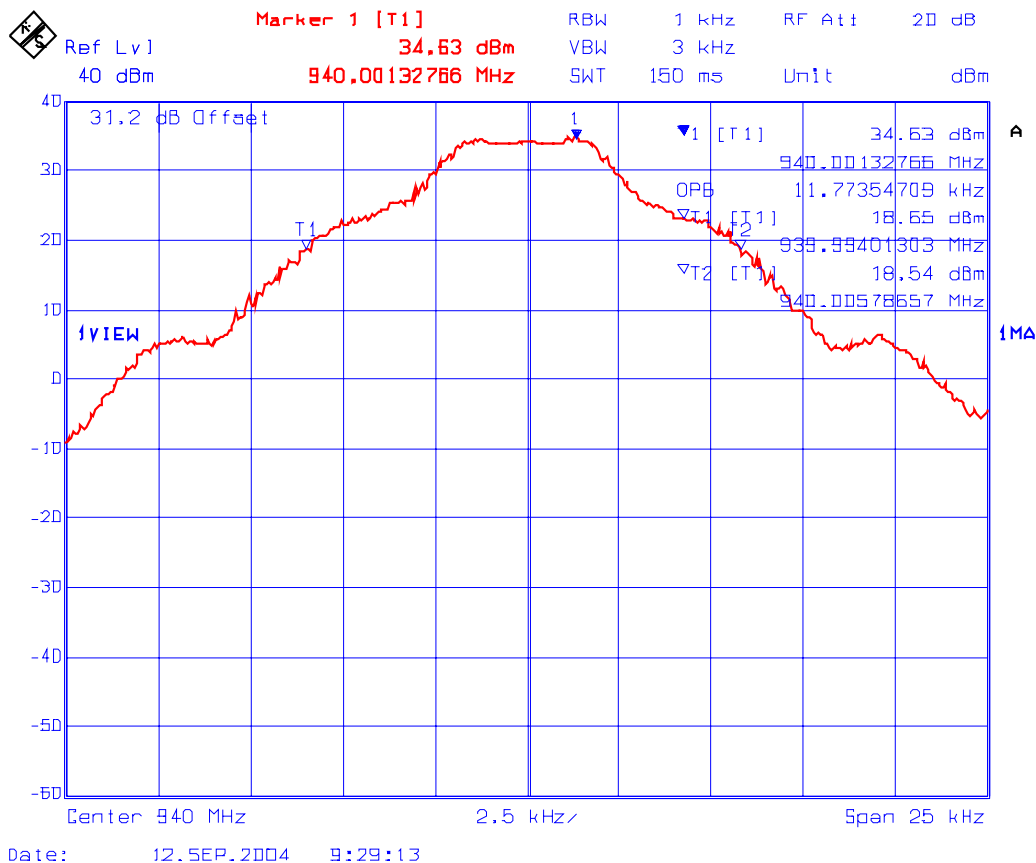

ULTRATECH GROUP OF LABS

3000 Bristol Circle, Oakville, Ontario, Canada L6H 6G4
 Tel. #: 905-829-1570, Fax. #: 905-829-8050, Email: vic@ultratech-labs.com, Website: <http://www.ultratech-labs.com>

File #: TXRX-009FCC90

October 14, 2004

All test results contained in this engineering test report are traceable to National Institute of Standards and Technology (NIST)

6.7.5.3. Emission Masks and Band-Edge Emissions

Conform.

896 - 901 MHz Band

- Emission Mask I for FM Voice Modulation with 2.5 kHz Sine Wave Signal, Permitted Band 896-901 MHz, 12.5 kHz Channel Spacing: refer to Plots # 31 to 34 for details.
- Emission Mask J for FM Data Modulation with an external 9600 b/s random data source, Permitted Band 896-901 MHz, 12.5 kHz Channel Spacing: refer to Plots # 35 to 38 for details.

935 - 940 MHz Band

- Emission Mask I for FM Voice Modulation with 2.5 kHz Sine Wave Signal, Permitted Band 935-940 MHz, 12.5 kHz Channel Spacing: refer to Plots # 39 to 42 for details.
- Emission Mask J for FM Data Modulation with an external 9600 b/s random data source, Permitted Band 935-940 MHz, 12.5 kHz Channel Spacing: refer to Plots # 43 to 46 for details.

PLOT # 31 **Emission Mask I, 896 - 901 MHz Band - RF Input**
Frequency: 896 MHz, 12.5 kHz Channel Spacing
Modulation: FM modulation with 2.5 kHz Sine wave signal

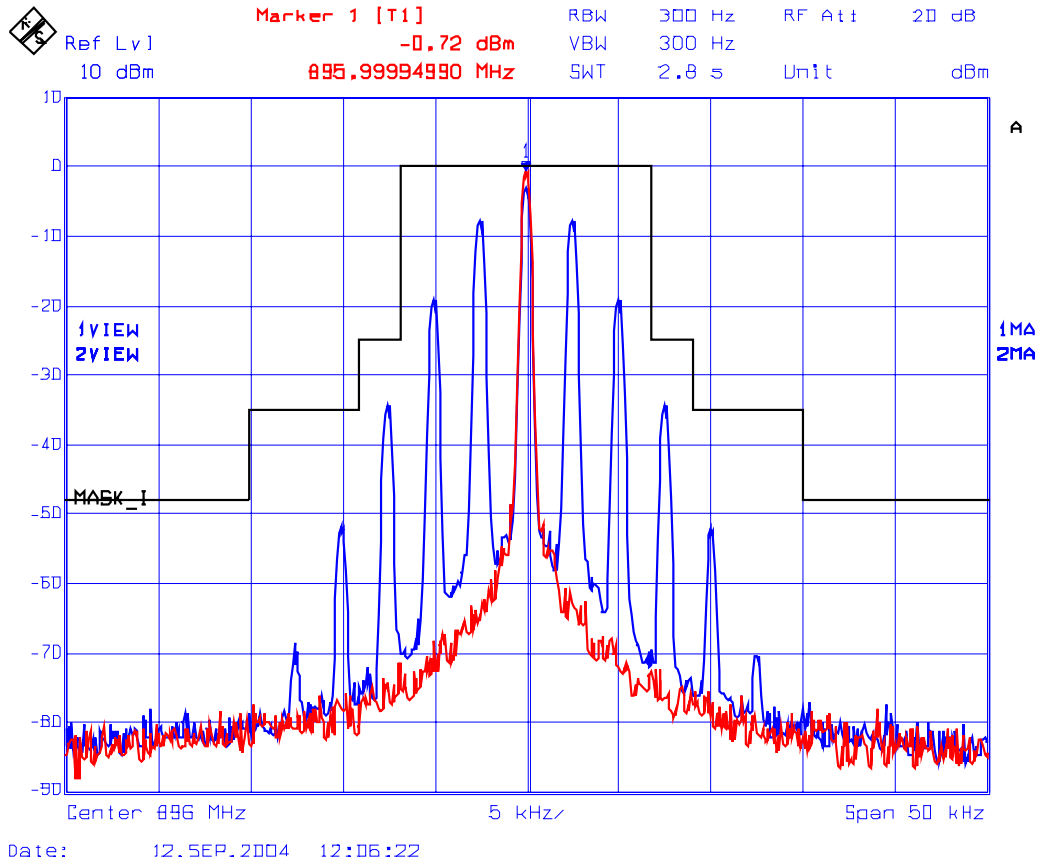

ULTRATECH GROUP OF LABS

3000 Bristol Circle, Oakville, Ontario, Canada L6H 6G4
Tel. #: 905-829-1570, Fax. #: 905-829-8050, Email: vic@ultratech-labs.com, Website: <http://www.ultratech-labs.com>

File #: TXRX-009FCC90

October 14, 2004

All test results contained in this engineering test report are traceable to National Institute of Standards and Technology (NIST)

PLOT # 32 **Emission Mask I, 896-901 MHz Band - RF Output**
Frequency: 896 MHz, 12.5 kHz Channel Spacing
Modulation: FM modulation with 2.5 kHz Sine wave signal

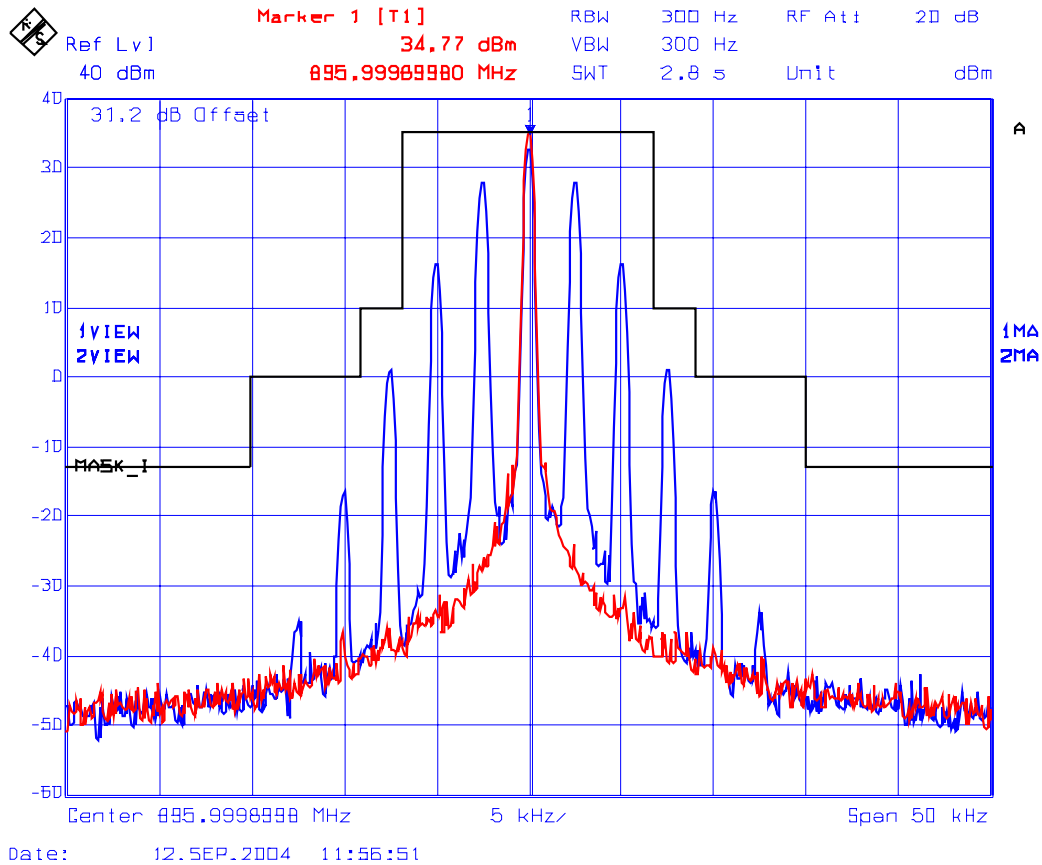

ULTRATECH GROUP OF LABS

3000 Bristol Circle, Oakville, Ontario, Canada L6H 6G4
Tel. #: 905-829-1570, Fax. #: 905-829-8050, Email: vic@ultratech-labs.com, Website: <http://www.ultratech-labs.com>

File #: TXRX-009FCC90

October 14, 2004

All test results contained in this engineering test report are traceable to National Institute of Standards and Technology (NIST)

PLOT # 33 **Emission Mask I, 896-901 MHz Band - RF Input**
Frequency: 901 MHz, 12.5 kHz Channel Spacing
Modulation: FM modulation with 2.5 kHz Sine wave signal

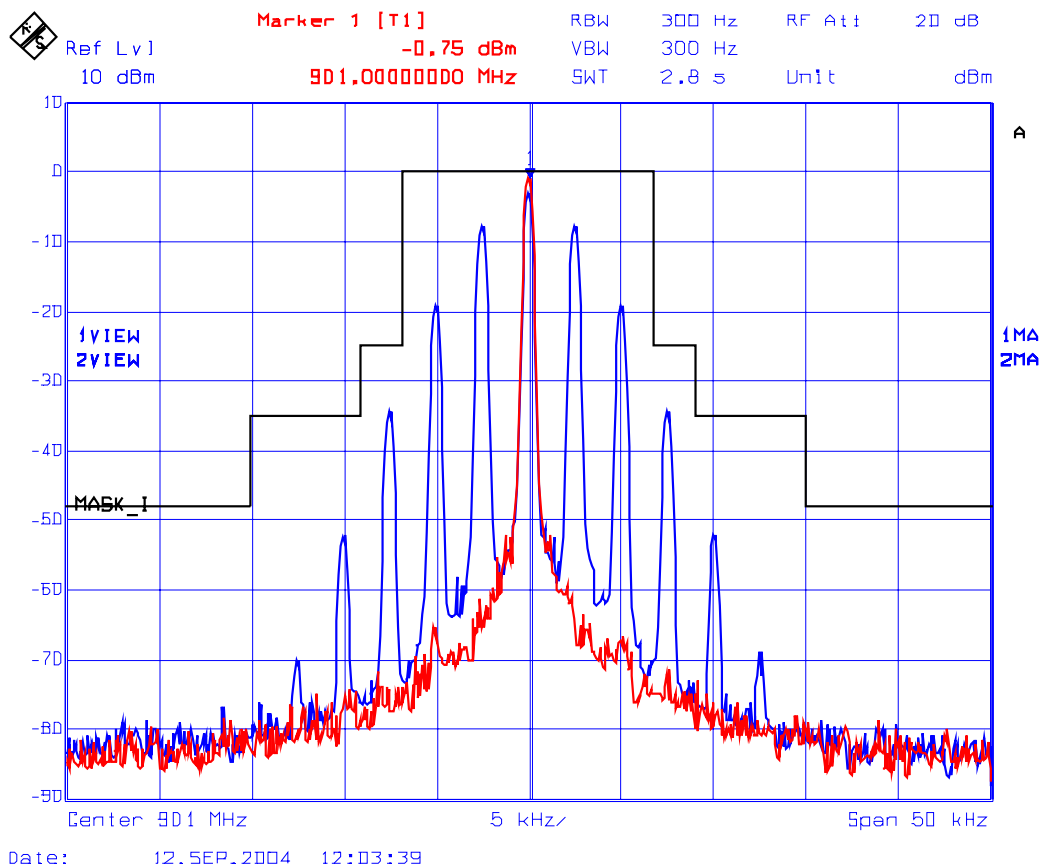

ULTRATECH GROUP OF LABS

3000 Bristol Circle, Oakville, Ontario, Canada L6H 6G4
Tel. #: 905-829-1570, Fax. #: 905-829-8050, Email: vic@ultratech-labs.com, Website: <http://www.ultratech-labs.com>

File #: TXRX-009FCC90

October 14, 2004

All test results contained in this engineering test report are traceable to National Institute of Standards and Technology (NIST)

PLOT # 34 **Emission Mask I, 896-901 MHz Band - RF Output**
Frequency: 901 MHz, 12.5 kHz Channel Spacing
Modulation: FM modulation with 2.5 kHz Sine wave signal

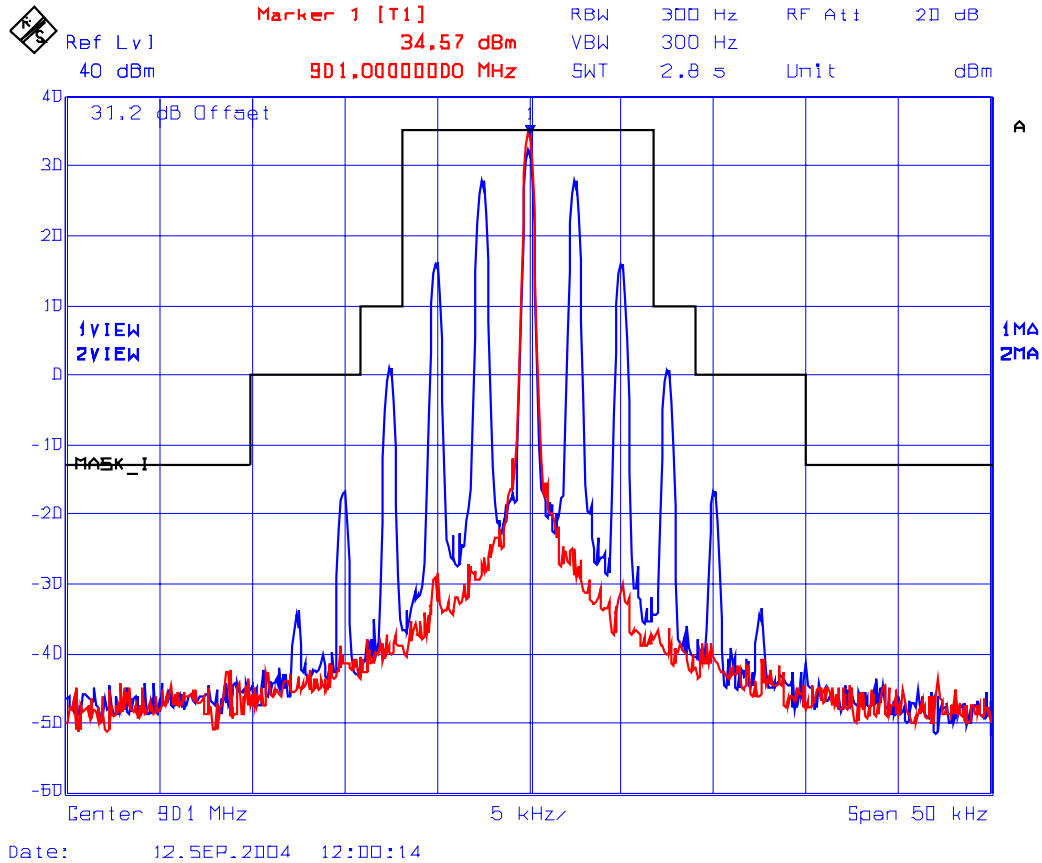

ULTRATECH GROUP OF LABS

3000 Bristol Circle, Oakville, Ontario, Canada L6H 6G4
Tel. #: 905-829-1570, Fax. #: 905-829-8050, Email: vic@ultratech-labs.com, Website: <http://www.ultratech-labs.com>

File #: TXRX-009FCC90

October 14, 2004

All test results contained in this engineering test report are traceable to National Institute of Standards and Technology (NIST)

PLOT # 35 **Emission Mask J, 896-901 MHz Band - RF Input**
Frequency: 896 MHz, 12.5 kHz Channel Spacing
Modulation: FM modulation with an external 9600 b/s random data source

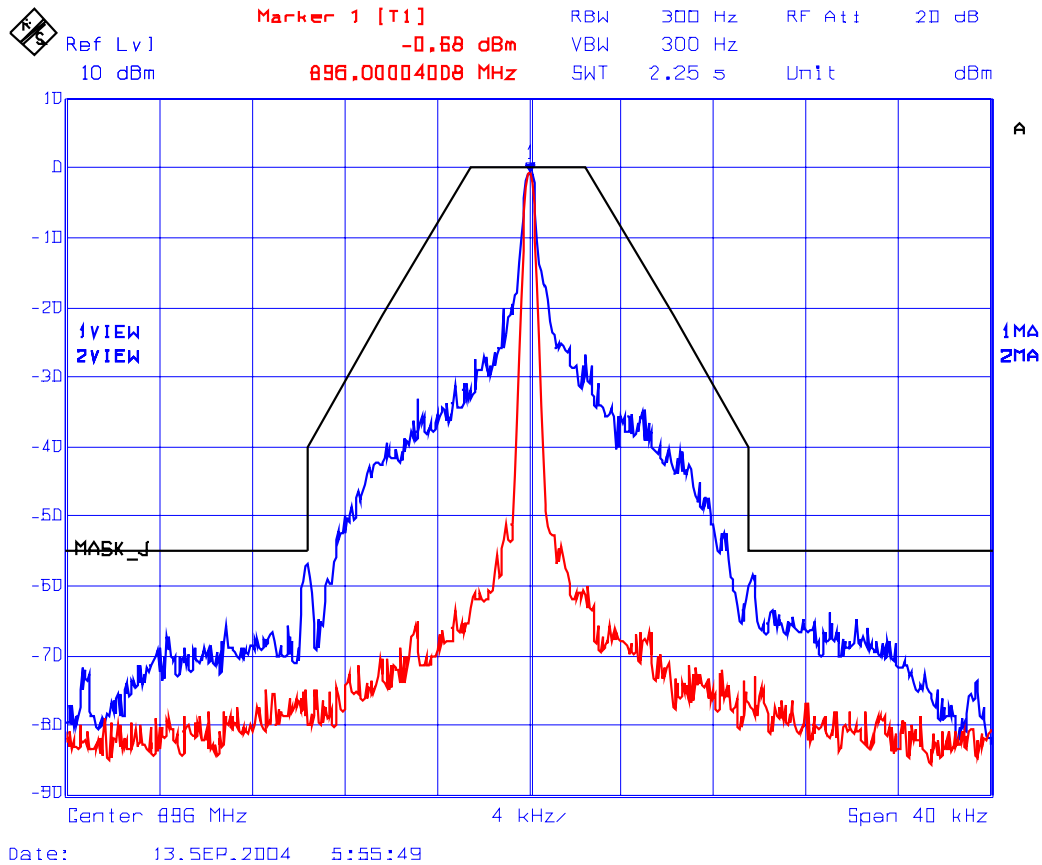

ULTRATECH GROUP OF LABS

3000 Bristol Circle, Oakville, Ontario, Canada L6H 6G4
Tel. #: 905-829-1570, Fax. #: 905-829-8050, Email: vic@ultratech-labs.com, Website: <http://www.ultratech-labs.com>

File #: TXRX-009FCC90

October 14, 2004

All test results contained in this engineering test report are traceable to National Institute of Standards and Technology (NIST)

PLOT # 36 **Emission Mask J, 896-901 MHz Band - RF Output**
Frequency: 896 MHz, 12.5 kHz Channel Spacing
Modulation: FM modulation with an external 9600 b/s random data source

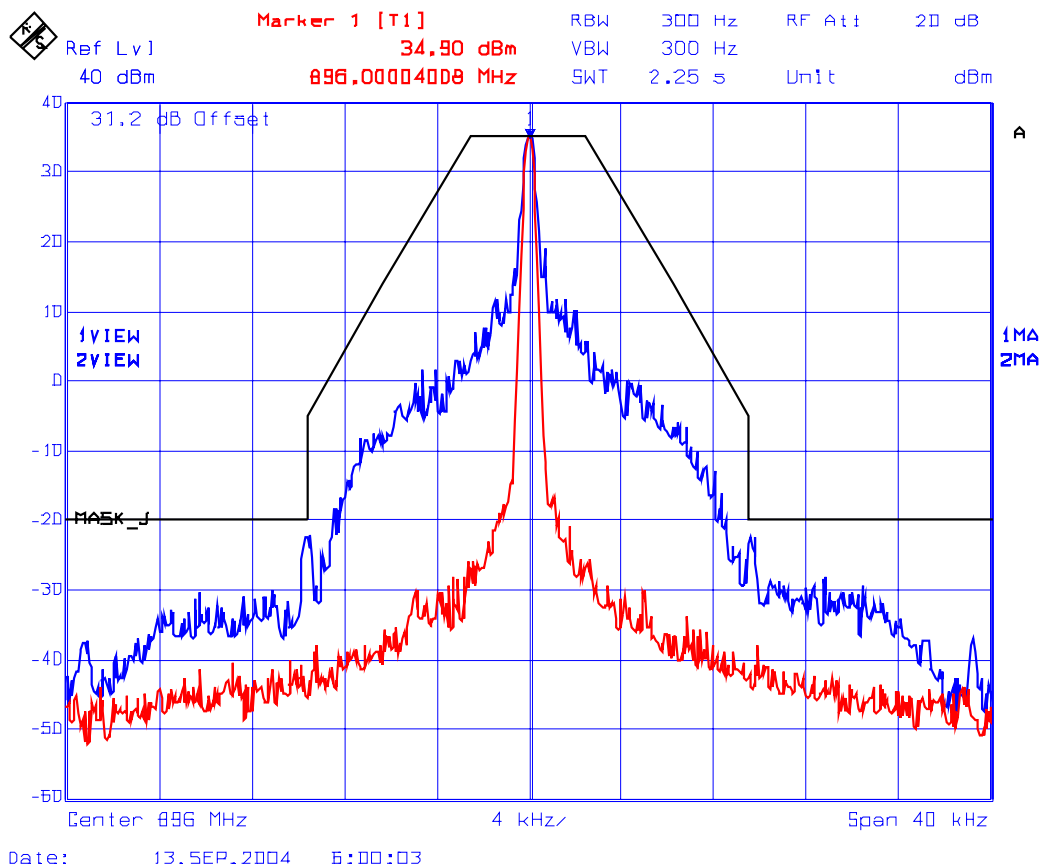

ULTRATECH GROUP OF LABS

3000 Bristol Circle, Oakville, Ontario, Canada L6H 6G4
Tel. #: 905-829-1570, Fax. #: 905-829-8050, Email: vic@ultratech-labs.com, Website: <http://www.ultratech-labs.com>

File #: TXRX-009FCC90

October 14, 2004

All test results contained in this engineering test report are traceable to National Institute of Standards and Technology (NIST)

PLOT # 37 **Emission Mask J, 896-901 MHz Band - RF Input**
Frequency: 901 MHz, 12.5 kHz Channel Spacing
Modulation: FM modulation with an external 9600 b/s random data source

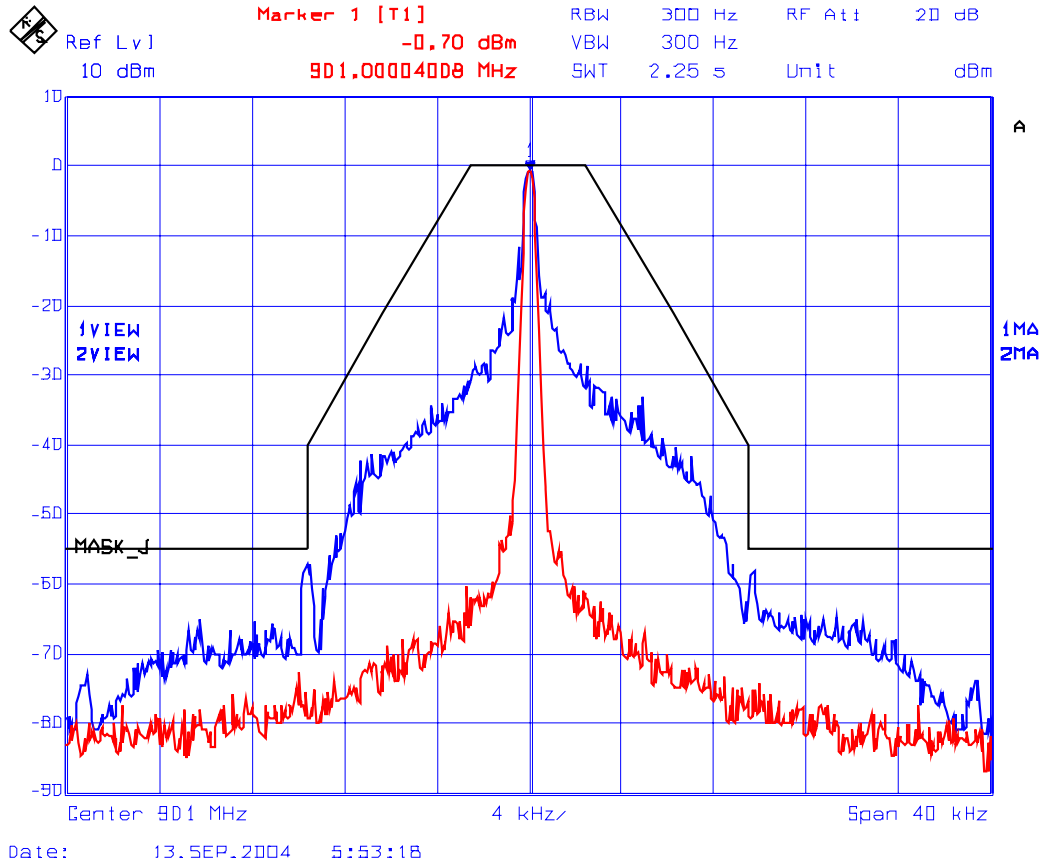

ULTRATECH GROUP OF LABS

3000 Bristol Circle, Oakville, Ontario, Canada L6H 6G4
Tel. #: 905-829-1570, Fax. #: 905-829-8050, Email: vic@ultratech-labs.com, Website: <http://www.ultratech-labs.com>

File #: TXRX-009FCC90

October 14, 2004

All test results contained in this engineering test report are traceable to National Institute of Standards and Technology (NIST)

PLOT # 38 **Emission Mask J, 896-901 MHz Band - RF Output**
Frequency: 901 MHz, 12.5 kHz Channel Spacing
Modulation: FM modulation with an external 9600 b/s random data source

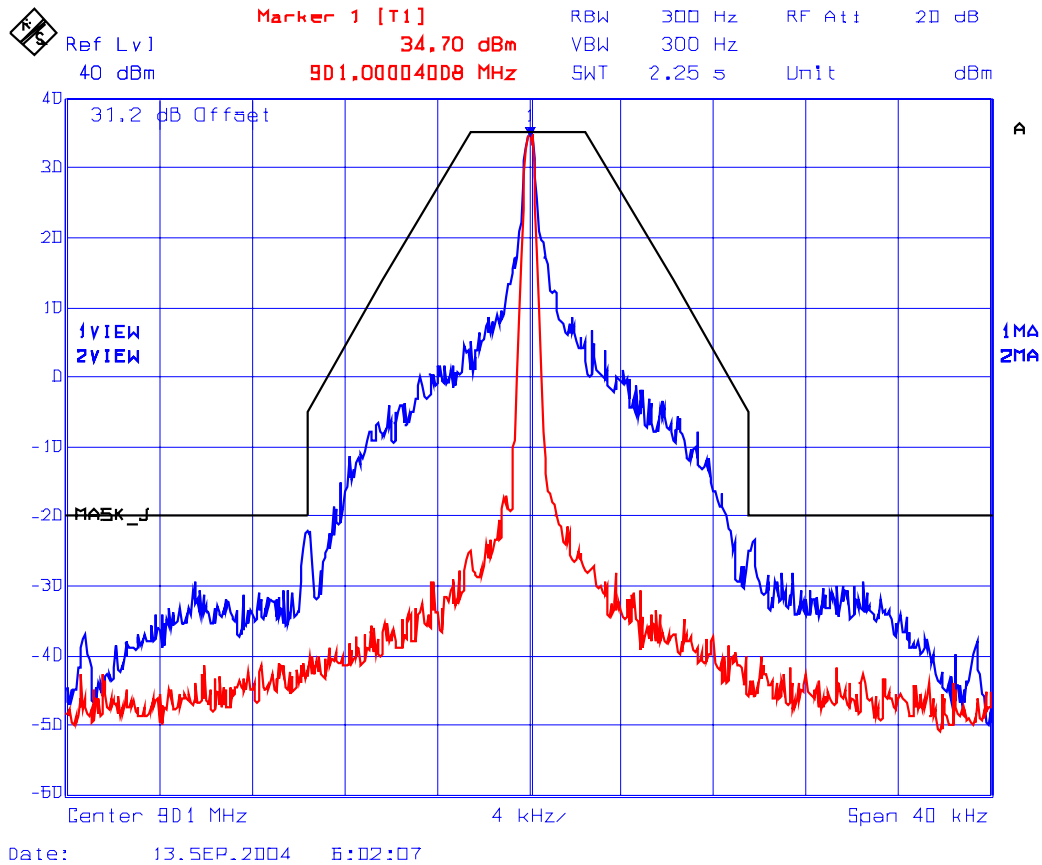

ULTRATECH GROUP OF LABS

3000 Bristol Circle, Oakville, Ontario, Canada L6H 6G4
Tel. #: 905-829-1570, Fax. #: 905-829-8050, Email: vic@ultratech-labs.com, Website: <http://www.ultratech-labs.com>

File #: TXRX-009FCC90

October 14, 2004

All test results contained in this engineering test report are traceable to National Institute of Standards and Technology (NIST)

PLOT # 39 Emission Mask I, 935-940 MHz Band - RF Input
Frequency: 935 MHz, 12.5 kHz Channel Spacing
Modulation: FM modulation with 2.5 kHz Sine wave signal

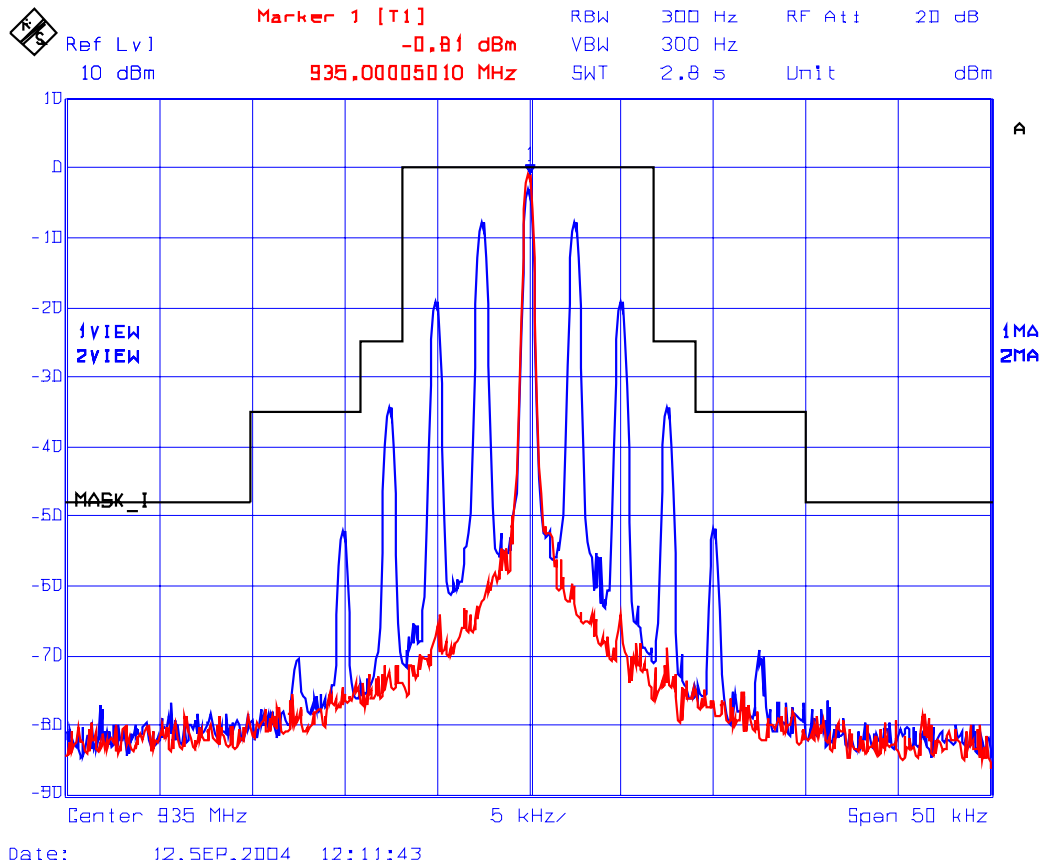

ULTRATECH GROUP OF LABS

3000 Bristol Circle, Oakville, Ontario, Canada L6H 6G4
Tel. #: 905-829-1570, Fax. #: 905-829-8050, Email: vic@ultratech-labs.com, Website: <http://www.ultratech-labs.com>

File #: TXRX-009FCC90

October 14, 2004

All test results contained in this engineering test report are traceable to National Institute of Standards and Technology (NIST)

PLOT # 40 **Emission Mask I, 935-940 MHz Band - RF Output**
Frequency: 935 MHz, 12.5 kHz Channel Spacing
Modulation: FM modulation with 2.5 kHz Sine wave signal

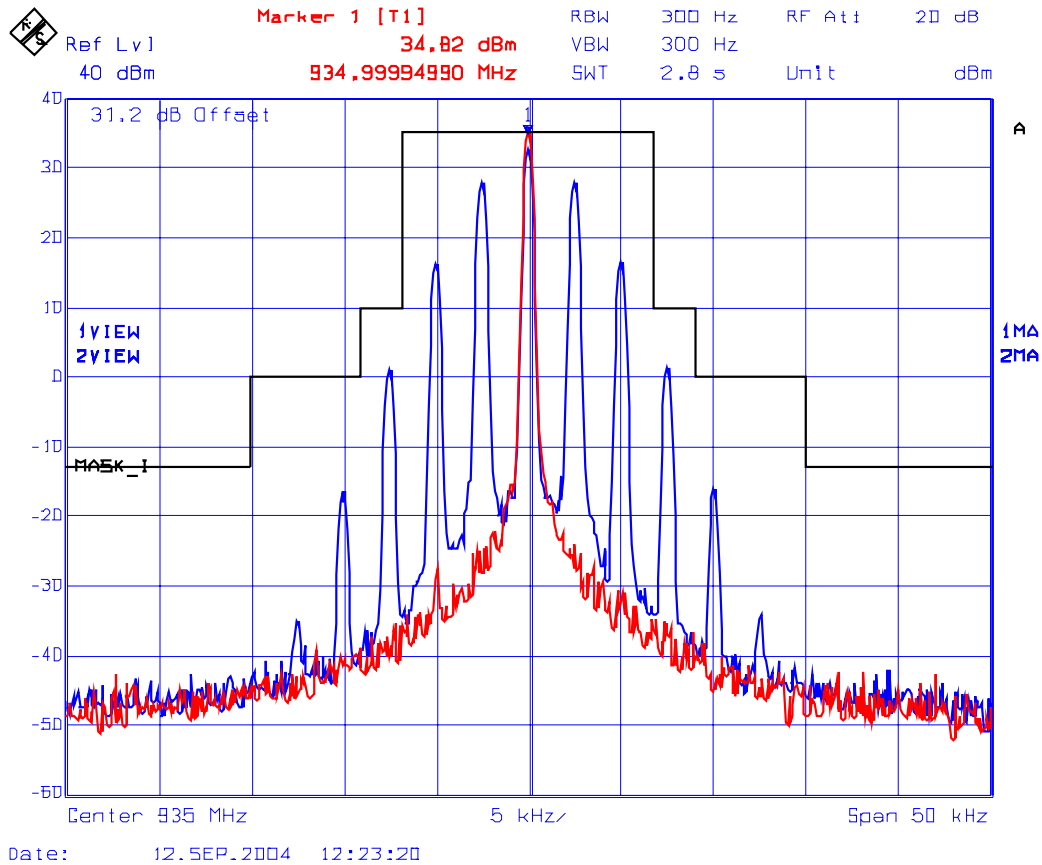

ULTRATECH GROUP OF LABS

3000 Bristol Circle, Oakville, Ontario, Canada L6H 6G4
Tel. #: 905-829-1570, Fax. #: 905-829-8050, Email: vic@ultratech-labs.com, Website: <http://www.ultratech-labs.com>

File #: TXRX-009FCC90

October 14, 2004

All test results contained in this engineering test report are traceable to National Institute of Standards and Technology (NIST)

PLOT # 41 **Emission Mask I, 935-940 MHz Band - RF Input**
Frequency: 940 MHz, 12.5 kHz Channel Spacing
Modulation: FM modulation with 2.5 kHz Sine wave signal

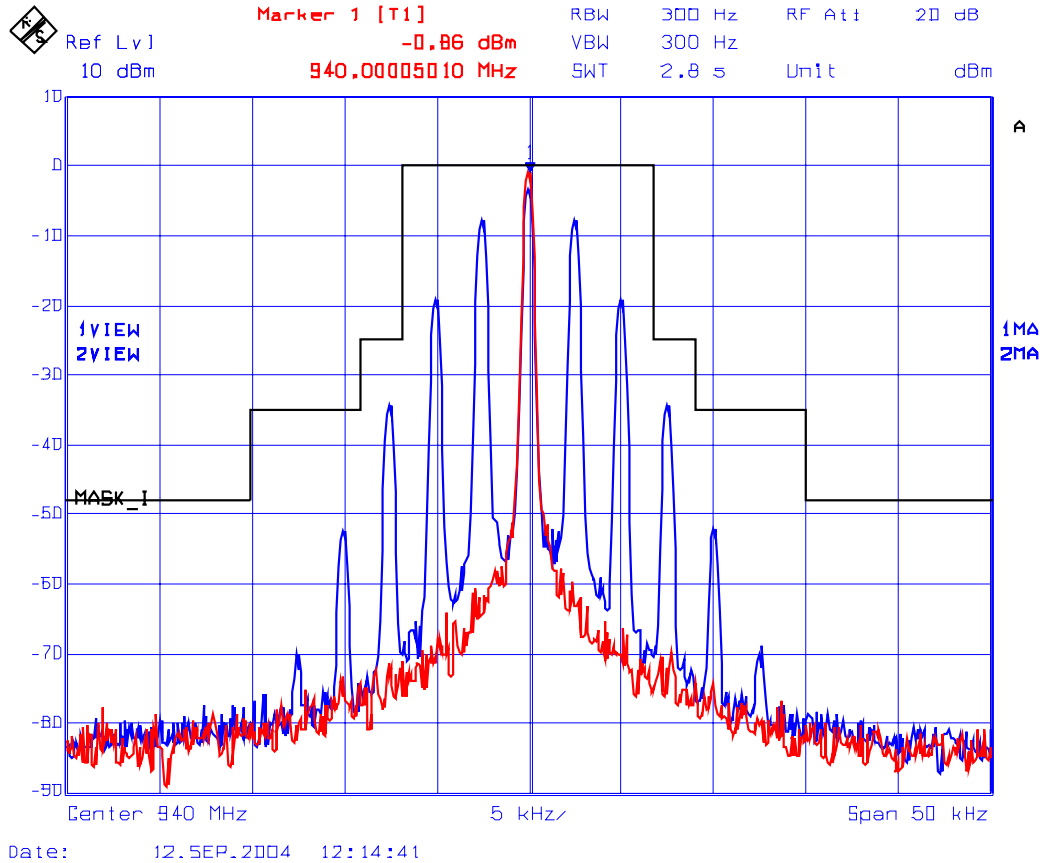

ULTRATECH GROUP OF LABS

3000 Bristol Circle, Oakville, Ontario, Canada L6H 6G4
Tel. #: 905-829-1570, Fax. #: 905-829-8050, Email: vic@ultratech-labs.com, Website: <http://www.ultratech-labs.com>

File #: TXRX-009FCC90

October 14, 2004

All test results contained in this engineering test report are traceable to National Institute of Standards and Technology (NIST)

PLOT # 42 **Emission Mask I, 935-940 MHz Band - RF Output**
Frequency: 940 MHz, 12.5 kHz Channel Spacing
Modulation: FM modulation with 2.5 kHz Sine wave signal

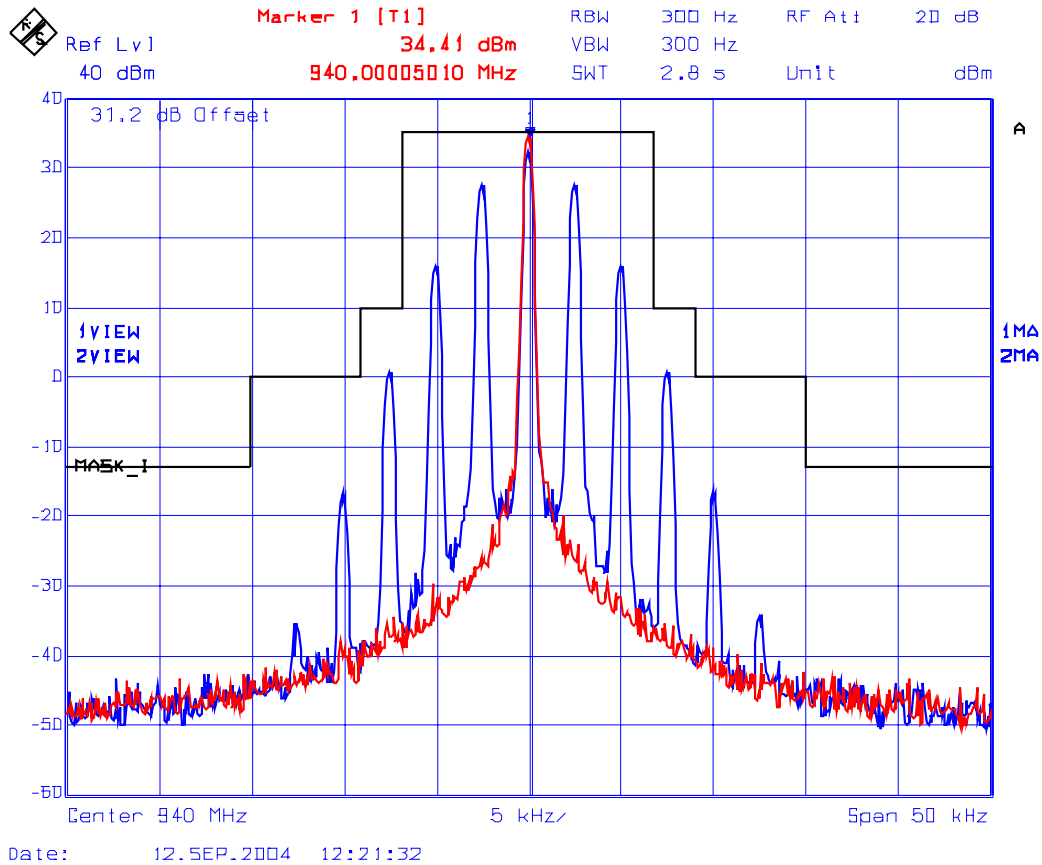

ULTRATECH GROUP OF LABS

3000 Bristol Circle, Oakville, Ontario, Canada L6H 6G4
Tel. #: 905-829-1570, Fax. #: 905-829-8050, Email: vic@ultratech-labs.com, Website: <http://www.ultratech-labs.com>

File #: TXRX-009FCC90

October 14, 2004

All test results contained in this engineering test report are traceable to National Institute of Standards and Technology (NIST)

PLOT # 43 **Emission Mask J, 935-940 MHz Band - RF Input**
Frequency: 935 MHz, 12.5 kHz Channel Spacing
Modulation: FM modulation with an external 9600 b/s random data source

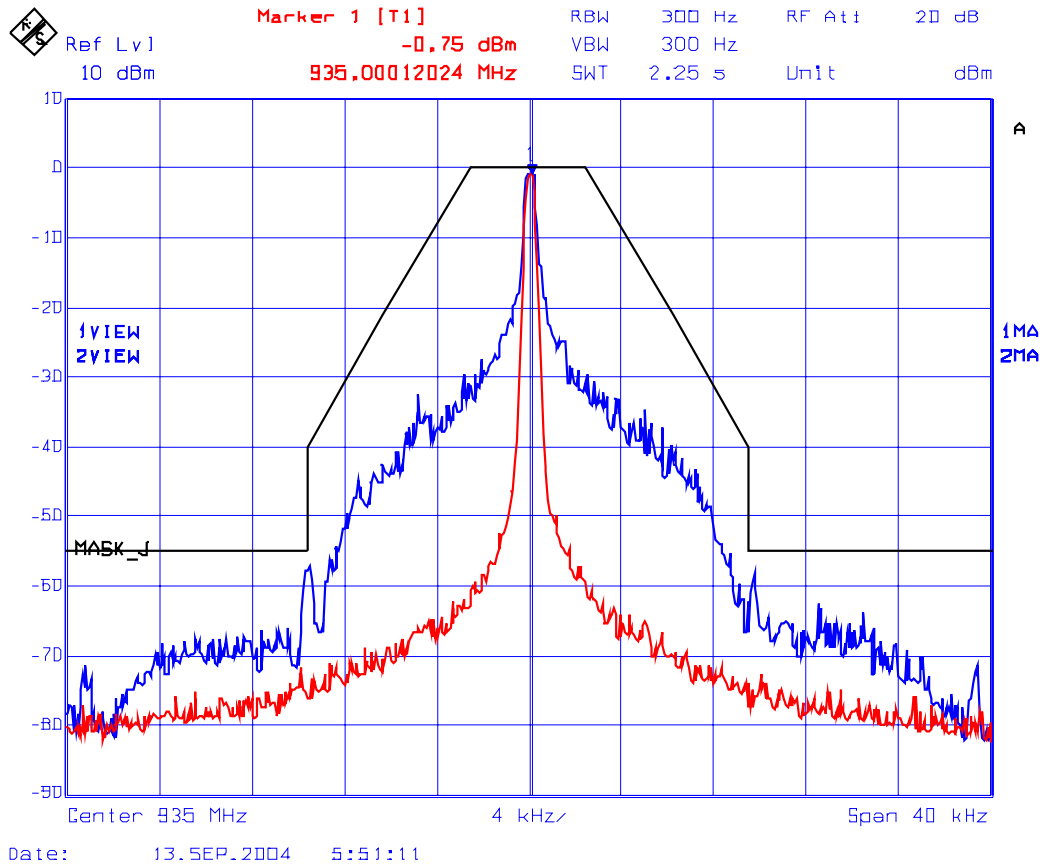

ULTRATECH GROUP OF LABS

3000 Bristol Circle, Oakville, Ontario, Canada L6H 6G4
Tel. #: 905-829-1570, Fax. #: 905-829-8050, Email: vic@ultratech-labs.com, Website: <http://www.ultratech-labs.com>

File #: TXRX-009FCC90

October 14, 2004

All test results contained in this engineering test report are traceable to National Institute of Standards and Technology (NIST)

PLOT # 44 **Emission Mask H, 935-940 MHz Band - RF Output**
Frequency: 935 MHz, 12.5 kHz Channel Spacing
Modulation: FM modulation with an external 9600 b/s random data source

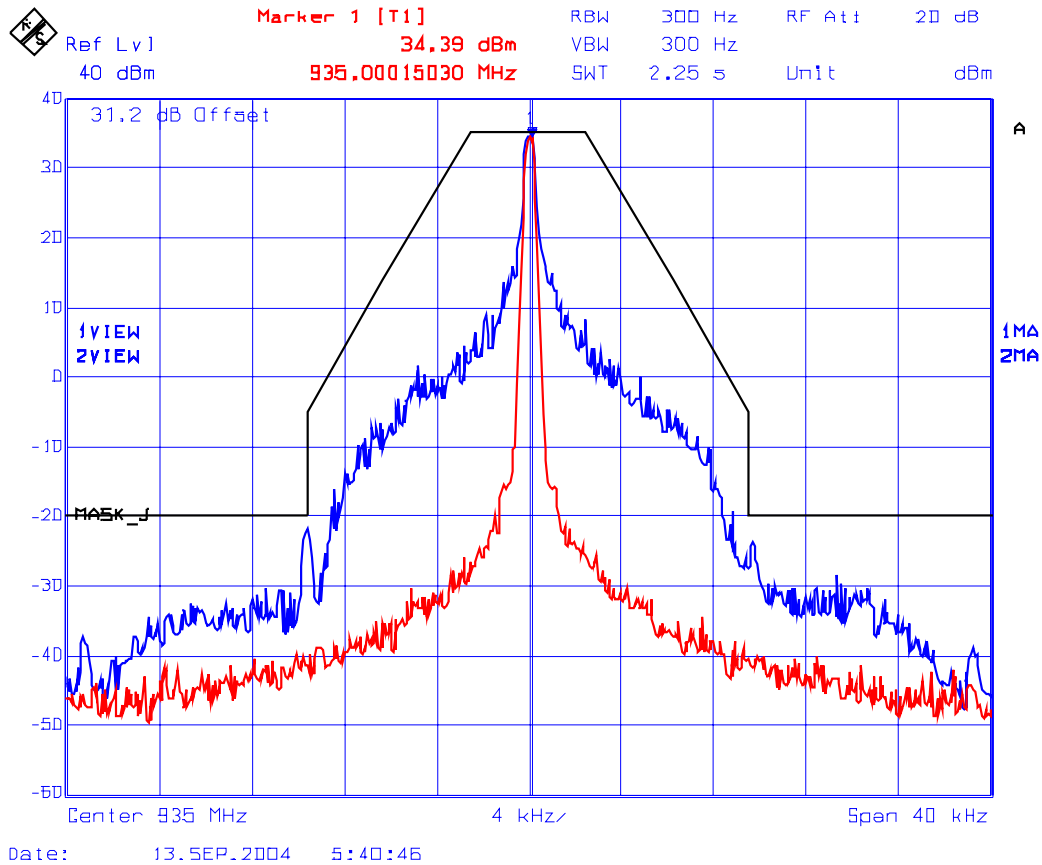

ULTRATECH GROUP OF LABS

3000 Bristol Circle, Oakville, Ontario, Canada L6H 6G4
Tel. #: 905-829-1570, Fax. #: 905-829-8050, Email: vic@ultratech-labs.com, Website: <http://www.ultratech-labs.com>

File #: TXRX-009FCC90

October 14, 2004

All test results contained in this engineering test report are traceable to National Institute of Standards and Technology (NIST)

PLOT # 45 **Emission Mask J, 935-940 MHz Band - RF Input**
Frequency: 940 MHz, 12.5 kHz Channel Spacing
Modulation: FM modulation with an external 9600 b/s random data source

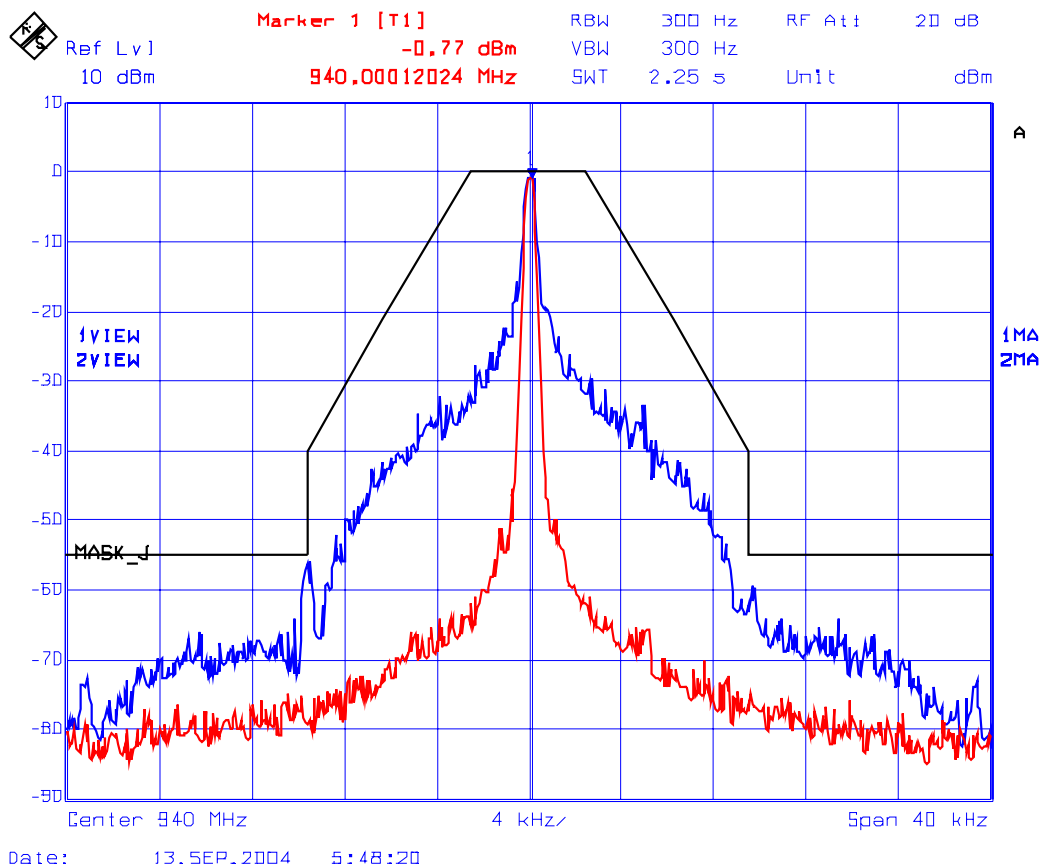

ULTRATECH GROUP OF LABS

3000 Bristol Circle, Oakville, Ontario, Canada L6H 6G4
Tel. #: 905-829-1570, Fax. #: 905-829-8050, Email: vic@ultratech-labs.com, Website: <http://www.ultratech-labs.com>

File #: TXRX-009FCC90

October 14, 2004

All test results contained in this engineering test report are traceable to National Institute of Standards and Technology (NIST)

PLOT # 46 Emission Mask J, 935-940 MHz Band - RF Output
Frequency: 940 MHz, 12.5 kHz Channel Spacing
Modulation: FM modulation with an external 9600 b/s random data source

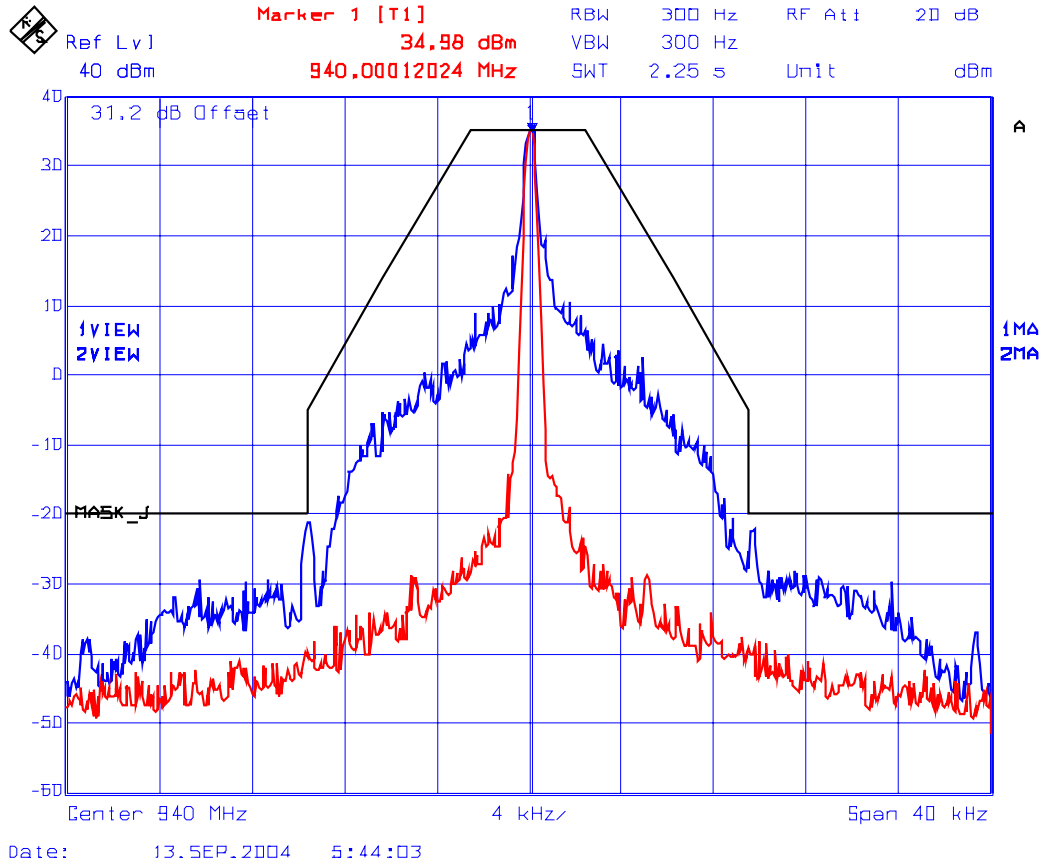

ULTRATECH GROUP OF LABS

3000 Bristol Circle, Oakville, Ontario, Canada L6H 6G4
Tel. #: 905-829-1570, Fax. #: 905-829-8050, Email: vic@ultratech-labs.com, Website: <http://www.ultratech-labs.com>

File #: TXRX-009FCC90

October 14, 2004

All test results contained in this engineering test report are traceable to National Institute of Standards and Technology (NIST)

6.8. TRANSMITTER ANTENNA POWER SPURIOUS/HARMONIC CONDUCTED EMISSIONS [§§ 2.1051, 90.209 & 90.210]

6.8.1. Limits

At least $50 + 10 \cdot \log(P \text{ in Watts})$ dBc.

6.8.2. Method of Measurements

Refer to ULTRATECH Test Procedures, File # ULTR P001-2004 and Exhibit 8 of this report for measurement details.

6.8.3. Test Equipment List

Test Instruments	Manufacturer	Model No.	Serial No.	Frequency Range
Spectrum Analyzer	Rohde & Schwarz	FSEK20/B4/B21	834157/005	9 kHz – 40 GHz
Attenuator	Weinschel Corp	46-20-34	BM1347	DC - 18 GHz
High Pass Filter	K & L	11SH10-1500/T8000-O/O	2	2 - 18 GHz
Signal Generator	Gigatronic	6061A	5130586	10 kHz - 1050 MHz

6.8.4. Test Arrangement

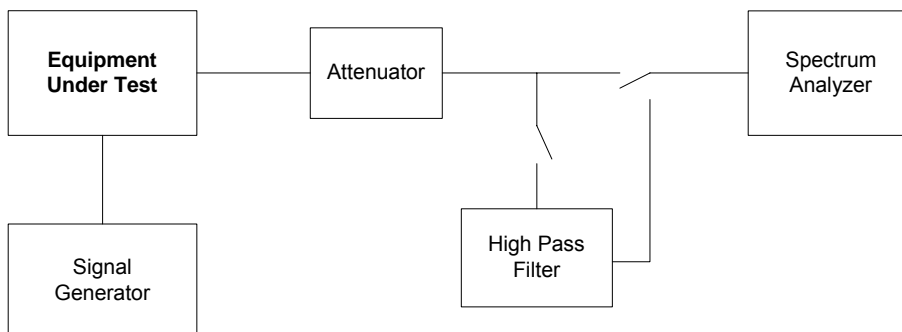

6.8.5. Test Data

Remarks:

- (1) There was no difference in spurious/harmonic emissions on pre-scans for all different modulations. Therefore, the rf spurious/harmonic emissions in this section would be performed without modulation and it shall represent for all different modulations required.
- (2) The emissions were scanned from 10 MHz to 10 GHz

6.8.5.1. Uplink Band 896-901 MHz

Fundamental Frequency: 896 MHz, 1 RF Signal input/output
RF Output Power: 34.7 dBm (conducted)
Modulation: Unmodulated

See the following plots (47 to 48) for details:

**PLOT # 47 Transmitter Conducted Spurious Emissions with 1 RF signal input/output
Fc: 896 MHz**

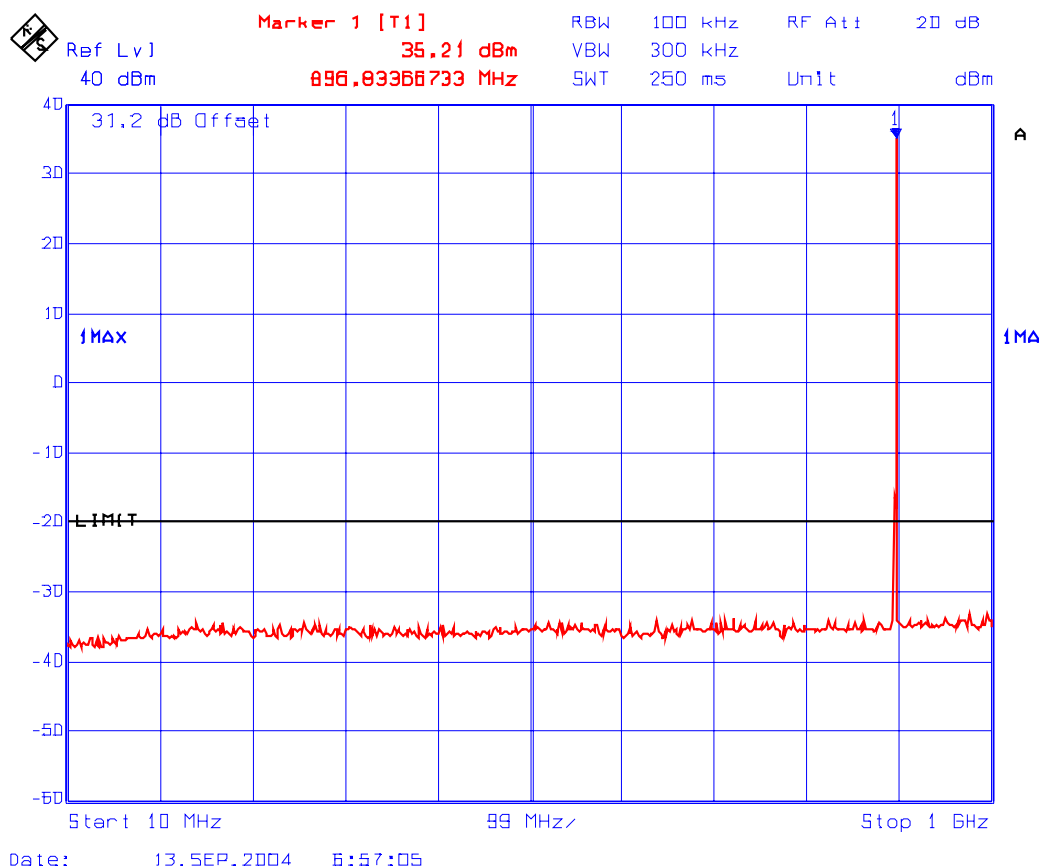

**PLOT # 48 Transmitter Conducted Spurious Emissions with 1 RF signal input/output
 Fc: 896 MHz**

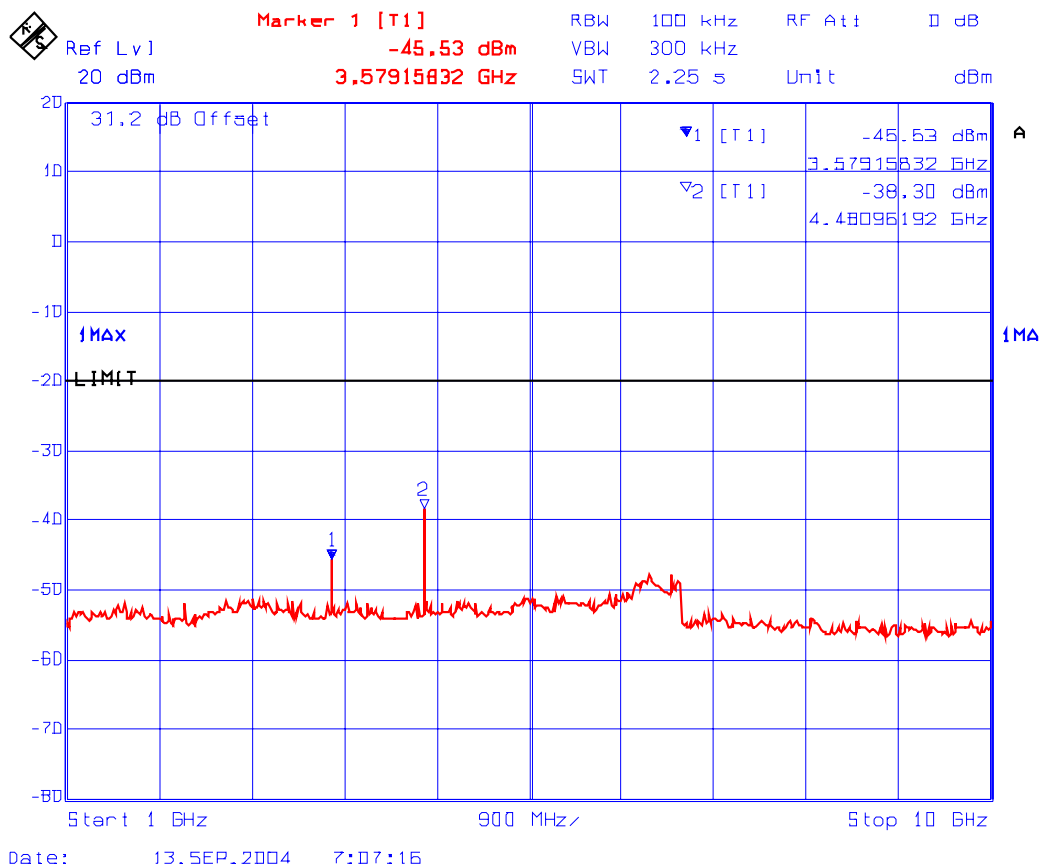

ULTRATECH GROUP OF LABS

3000 Bristol Circle, Oakville, Ontario, Canada L6H 6G4
 Tel. #: 905-829-1570, Fax. #: 905-829-8050, Email: vic@ultratech-labs.com, Website: <http://www.ultratech-labs.com>

File #: TXRX-009FCC90

October 14, 2004

All test results contained in this engineering test report are traceable to National Institute of Standards and Technology (NIST)

Fundamental Frequency: 896.0, 896.0125 MHz (2 channel inputs/outputs)
RF Output Power: 31.6 dBm (conducted)
Modulation: Unmodulated

See the following plots (49 to 50) for details:

**PLOT # 49 Transmitter Conducted Spurious Emissions with 2 RF signal inputs/outputs
Fc: 896.0 MHz, Fc + 12.5 kHz**

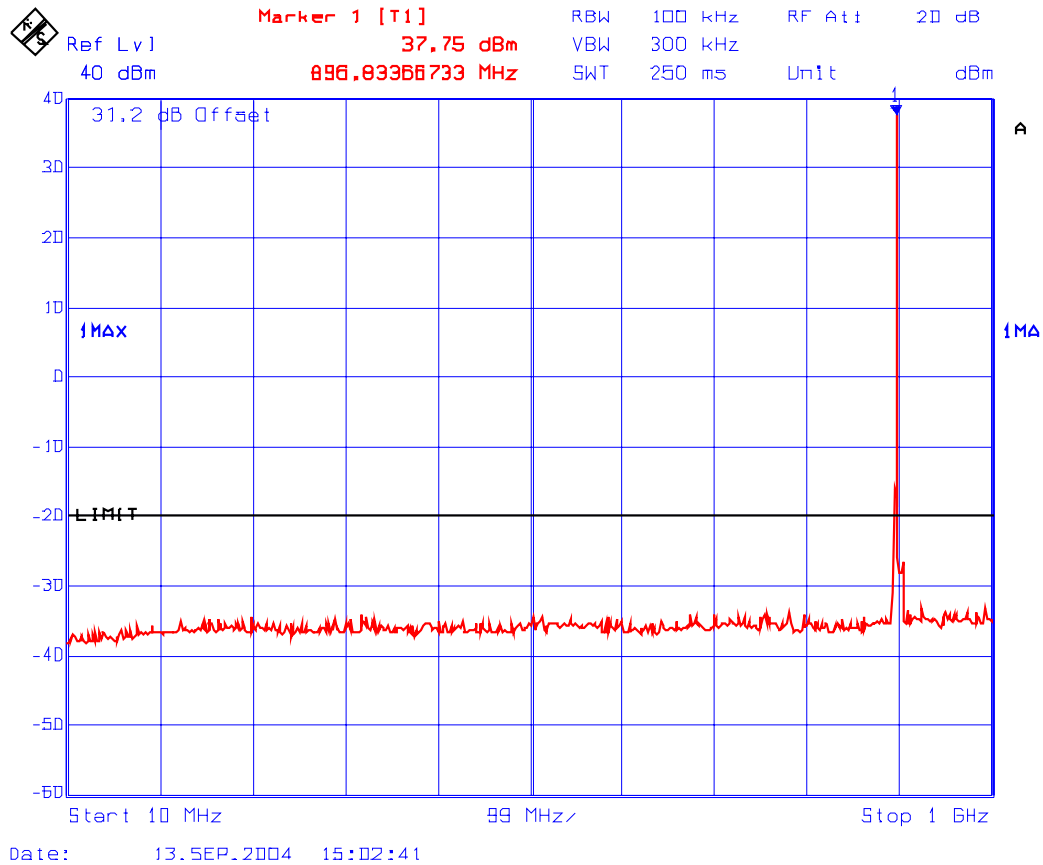

PLOT # 50 Transmitter Conducted Spurious Emissions with 2 RF signal inputs/outputs
Fc: 896 MHz, Fc + 12.5 kHz

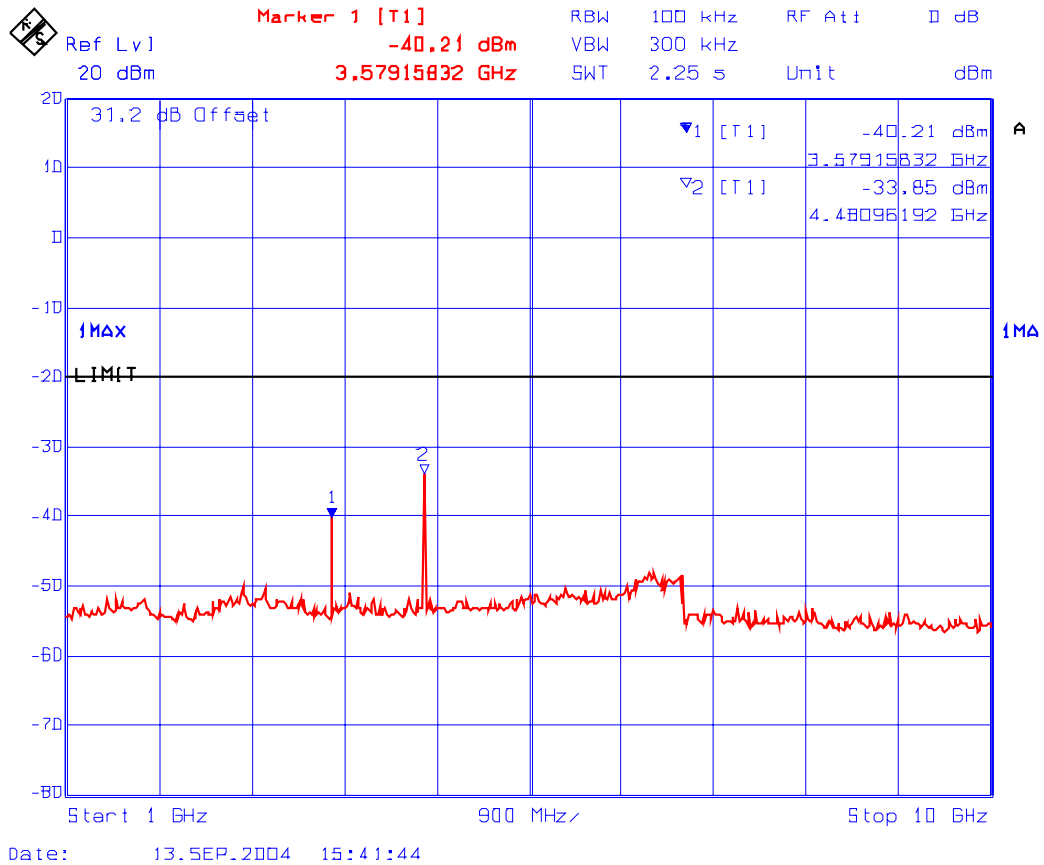

Fundamental Frequency: 896.0, 896.0125, 896.0250 (3 channel inputs/outputs)
RF Output Power: 27.1 dBm (conducted)
Modulation: Unmodulated

See the following plots (51 to 52) for details:

PLOT # 51 Transmitter Conducted Spurious Emissions with 3 RF signal inputs/outputs
Fc: 896 MHz, Fc + 12.5 kHz, Fc + 25 kHz

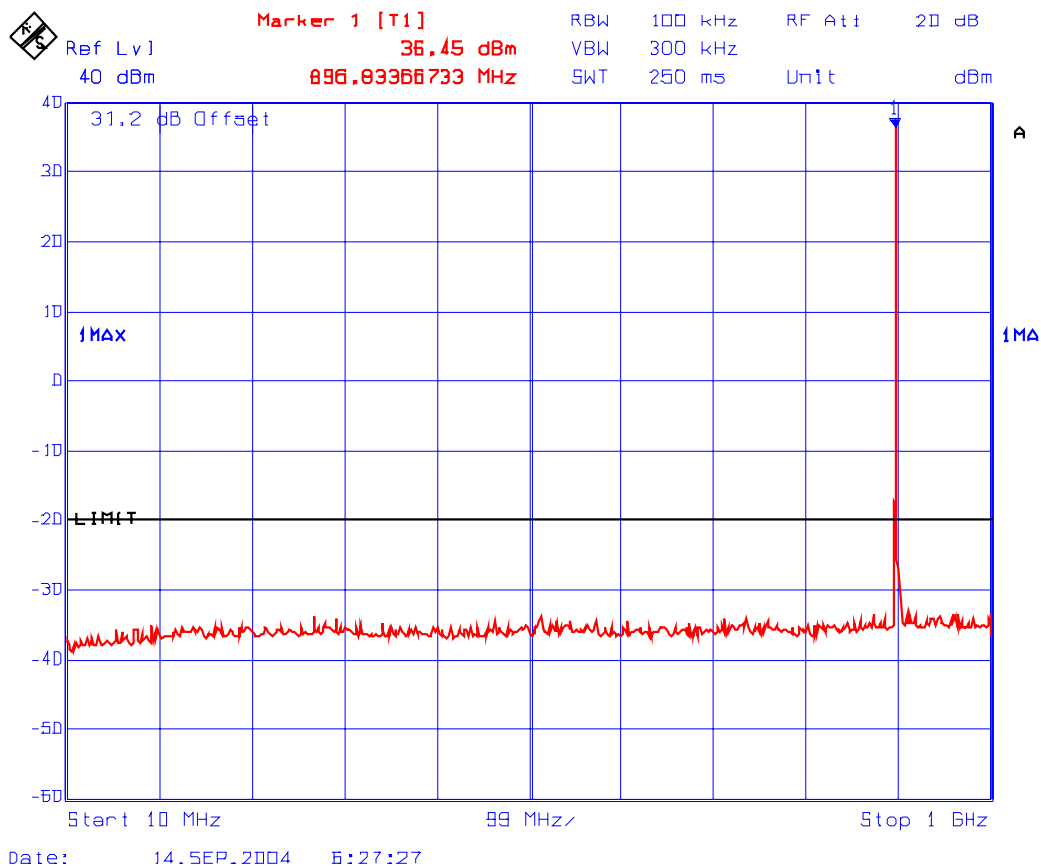

PLOT # 52 Transmitter Conducted Spurious Emissions with 3 RF signal inputs/outputs
Fc: 896 MHz, Fc + 12.5 kHz, Fc + 25 kHz

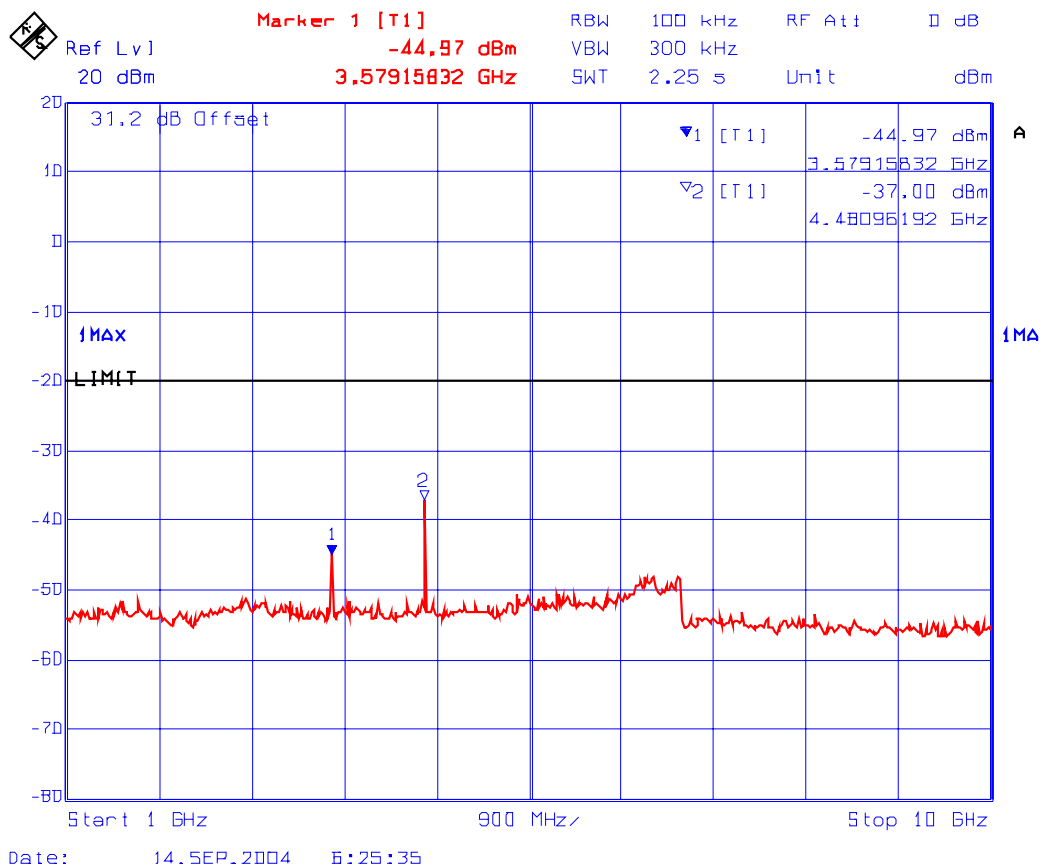

ULTRATECH GROUP OF LABS

3000 Bristol Circle, Oakville, Ontario, Canada L6H 6G4
Tel. #: 905-829-1570, Fax. #: 905-829-8050, Email: vic@ultratech-labs.com, Website: <http://www.ultratech-labs.com>

File #: TXRX-009FCC90

October 14, 2004

All test results contained in this engineering test report are traceable to National Institute of Standards and Technology (NIST)

Fundamental Frequency: 901 MHz, 1 RF Signal input/output
RF Output Power: 34.5 dBm (conducted)
Modulation: Unmodulated

See the following plots (53 to 54) for details:

**PLOT # 53 Transmitter Conducted Spurious Emissions with 1 RF signal input/output
Fc: 901 MHz**

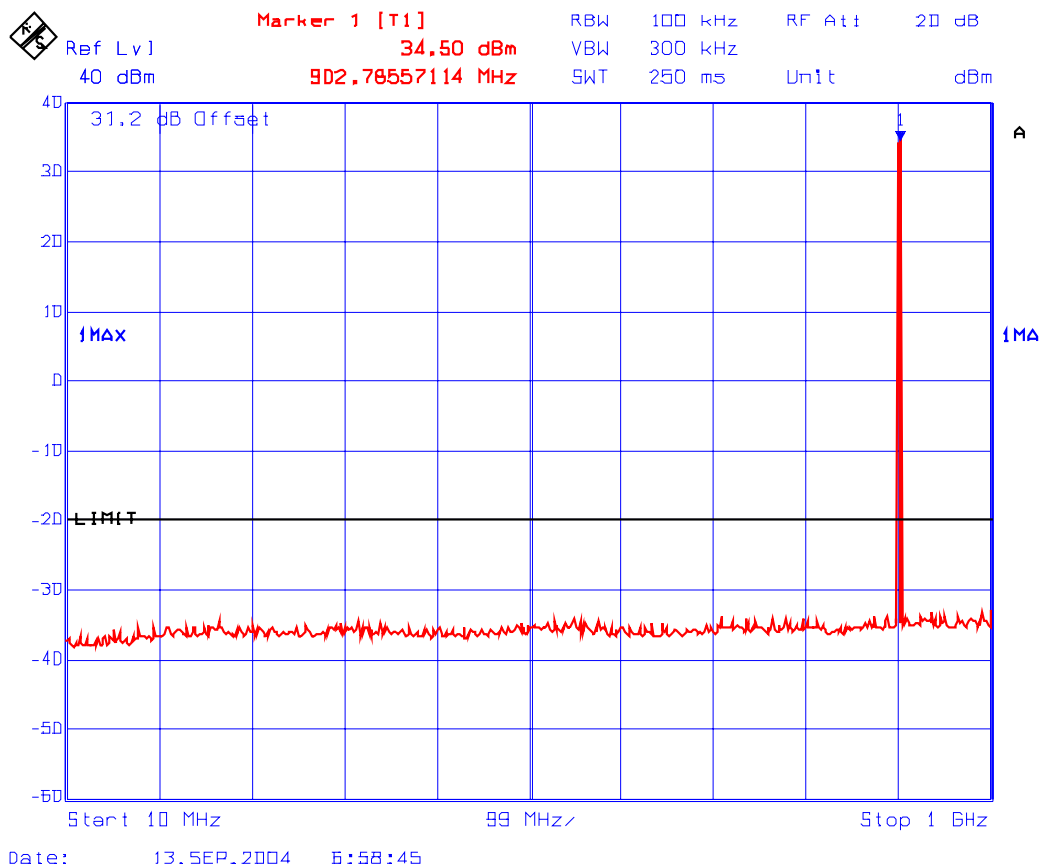

PLOT # 54 Transmitter Conducted Spurious Emissions with 1 RF signal input/output
Fc: 901 MHz

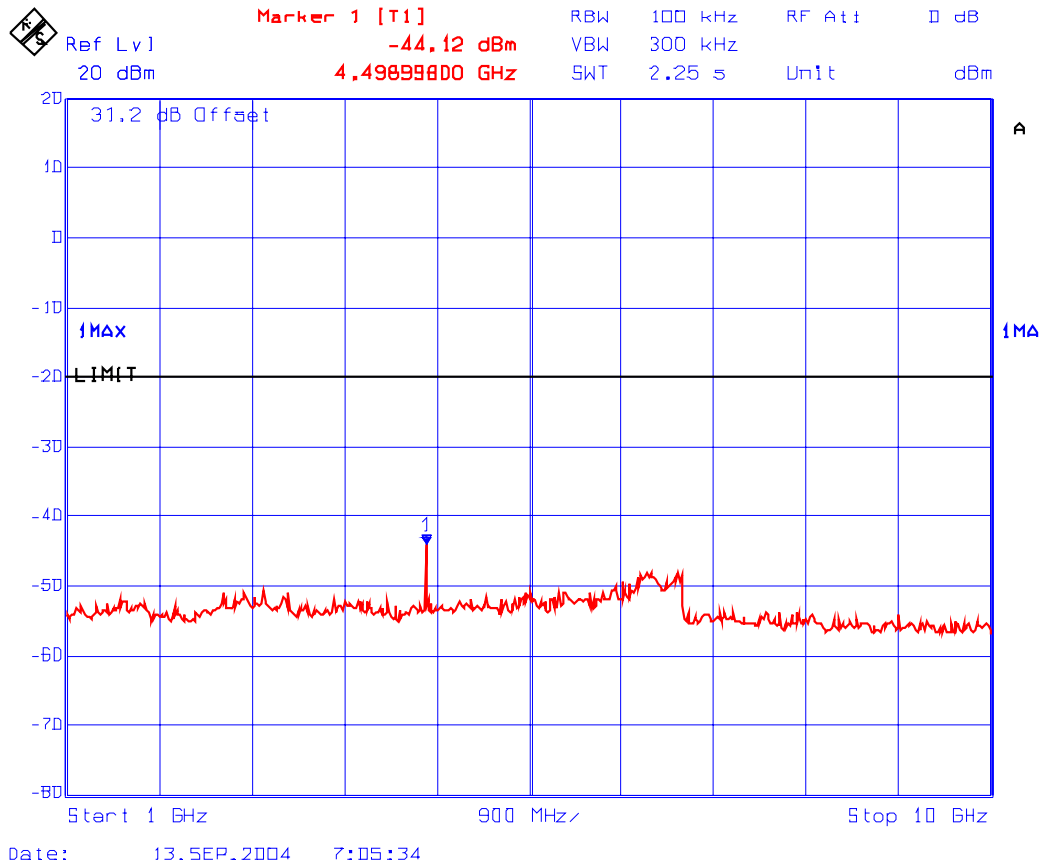

ULTRATECH GROUP OF LABS

3000 Bristol Circle, Oakville, Ontario, Canada L6H 6G4
Tel. #: 905-829-1570, Fax. #: 905-829-8050, Email: vic@ultratech-labs.com, Website: <http://www.ultratech-labs.com>

File #: TXRX-009FCC90

October 14, 2004

All test results contained in this engineering test report are traceable to National Institute of Standards and Technology (NIST)

Fundamental Frequency: 900.9875, 901MHz (2 channel inputs/outputs)
RF Output Power: 29.2 dBm (conducted)
Modulation: Unmodulated

See the following plots (55 to 56) for details:

**PLOT # 55 Transmitter Conducted Spurious Emissions with 2 RF signal input/output
Fc: 901 MHz, Fc – 12.5 kHz**

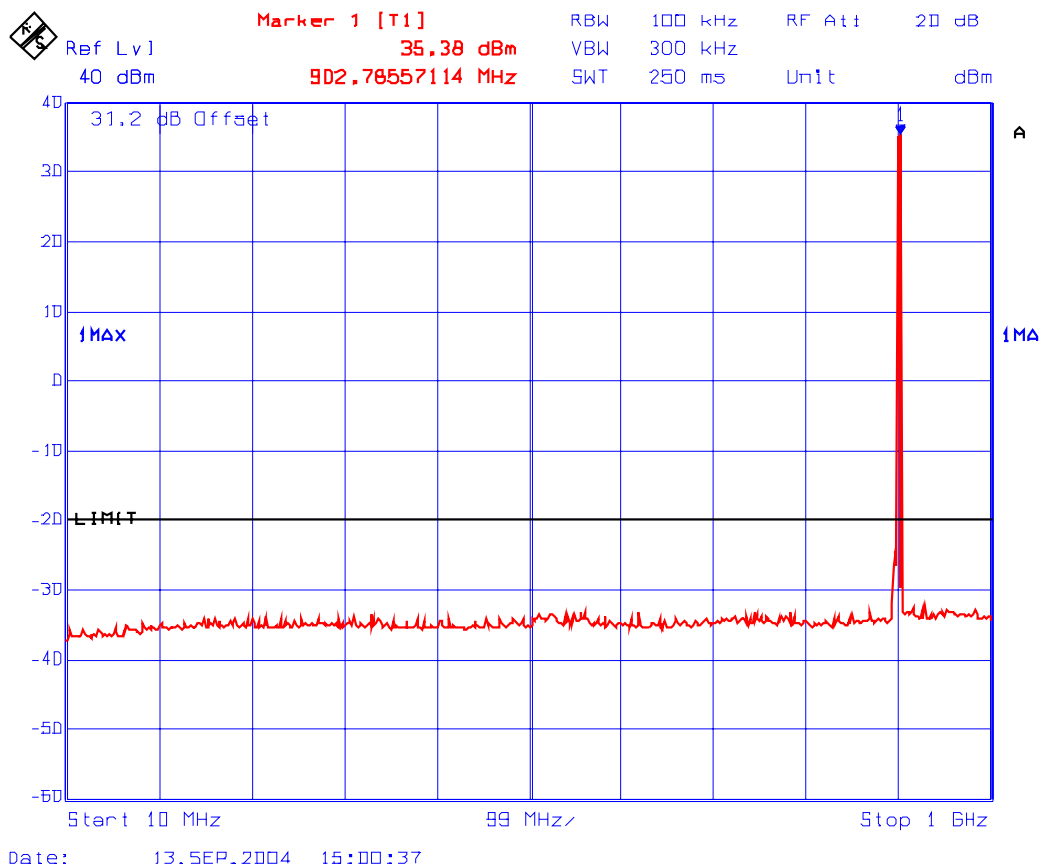

ULTRATECH GROUP OF LABS

3000 Bristol Circle, Oakville, Ontario, Canada L6H 6G4
Tel. #: 905-829-1570, Fax. #: 905-829-8050, Email: vic@ultratech-labs.com, Website: <http://www.ultratech-labs.com>

File #: TXRX-009FCC90

October 14, 2004

All test results contained in this engineering test report are traceable to National Institute of Standards and Technology (NIST)

PLOT # 56 Transmitter Spurious Emissions with 2 RF signal input/output
Fc: 901 MHz, Fc – 12.5 kHz

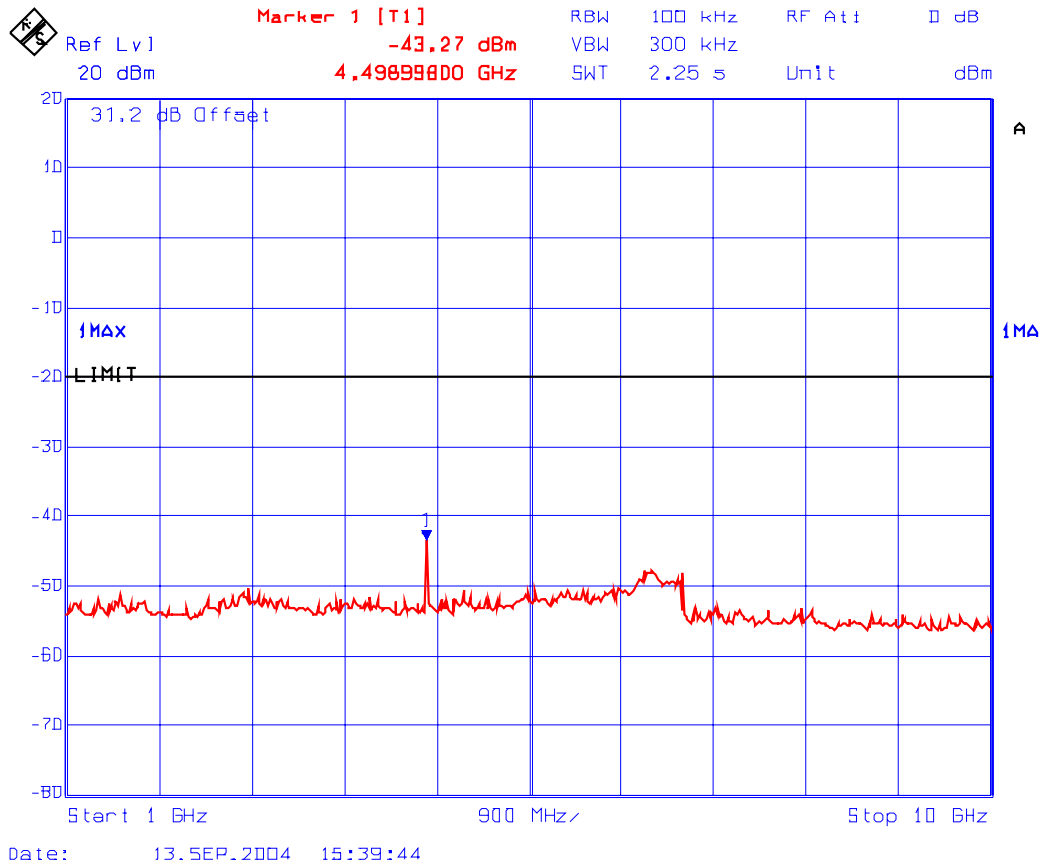

ULTRATECH GROUP OF LABS

3000 Bristol Circle, Oakville, Ontario, Canada L6H 6G4
Tel. #: 905-829-1570, Fax. #: 905-829-8050, Email: vic@ultratech-labs.com, Website: <http://www.ultratech-labs.com>

File #: TXRX-009FCC90

October 14, 2004

All test results contained in this engineering test report are traceable to National Institute of Standards and Technology (NIST)

Fundamental Frequency: 900.9750, 900.9875, 901 (3 channel inputs/outputs)
RF Output Power: 25.8 dBm (conducted)
Modulation: Unmodulated

See the following plots (57 to 58) for details:

PLOT # 57 Transmitter Conducted Spurious Emissions with 3 RF signal input/output
Fc: 901 MHz, Fc - 12.5 kHz, Fc - 25 kHz

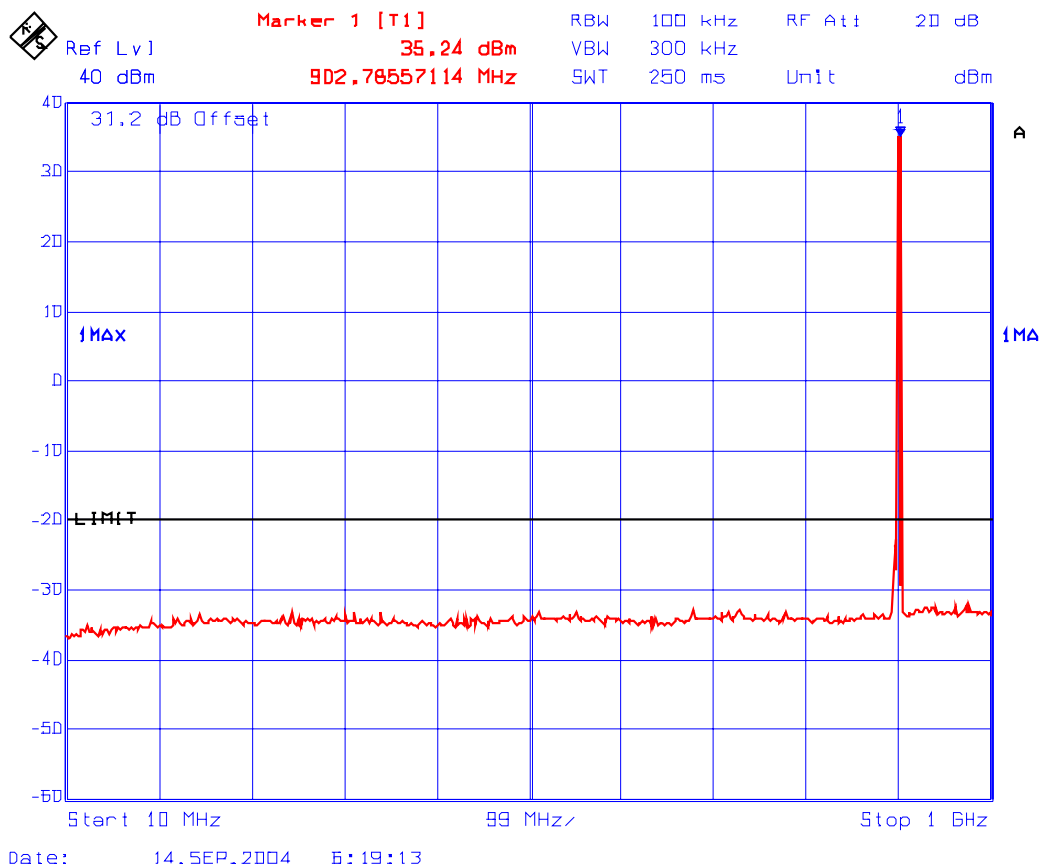

PLOT # 58 Transmitter Conducted Spurious Emissions with 3 RF signal input/output
Fc: 901 MHz, Fc - 12.5 kHz, Fc - 25 kHz



ULTRATECH GROUP OF LABS

3000 Bristol Circle, Oakville, Ontario, Canada L6H 6G4
Tel. #: 905-829-1570, Fax. #: 905-829-8050, Email: vic@ultratech-labs.com, Website: <http://www.ultratech-labs.com>

File #: TXRX-009FCC90

October 14, 2004

All test results contained in this engineering test report are traceable to National Institute of Standards and Technology (NIST)

6.8.5.2. Downlink Band 935-940 MHz

Fundamental Frequency: 935 MHz, 1 RF Signal input/output
RF Output Power: 35.0 dBm (conducted)
Modulation: Unmodulated

See the following plots (59 to 60) for details:

**PLOT # 59 Transmitter Conducted Spurious Emissions with 1 RF signal input/output
Fc: 935 MHz**

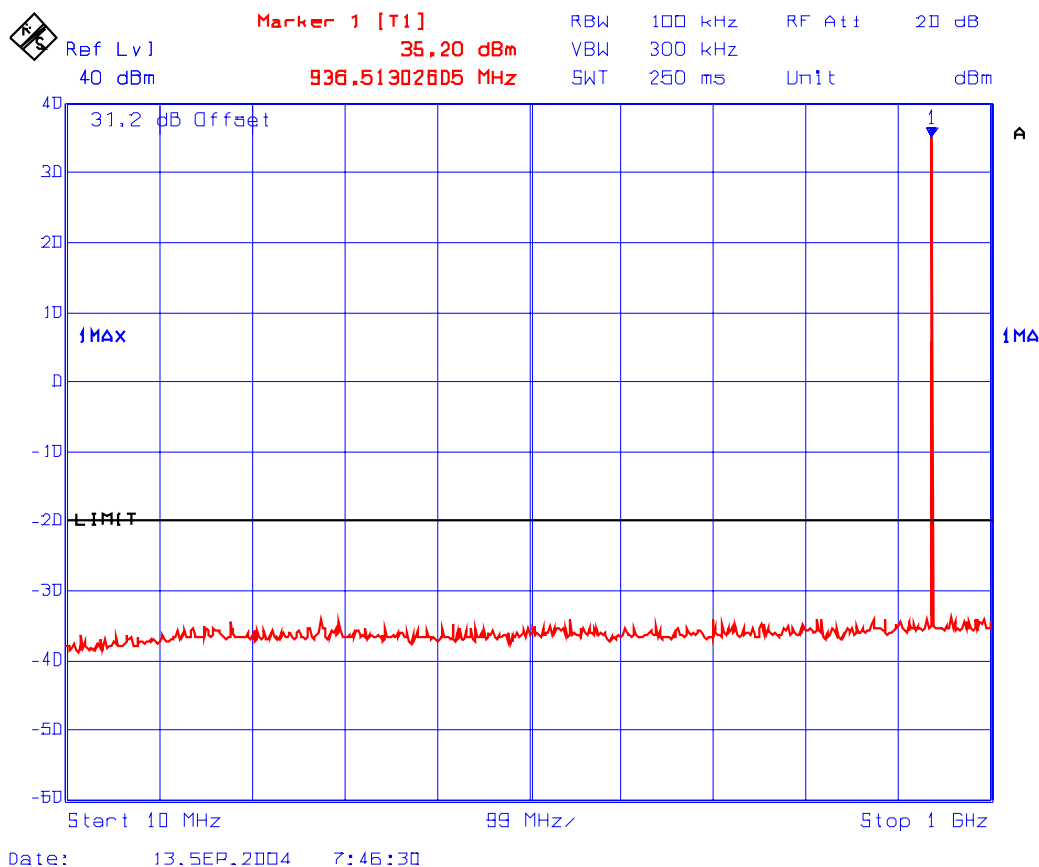

PLOT # 60 Transmitter Conducted Spurious Emissions with 1 RF signal input/output
Fc: 935 MHz

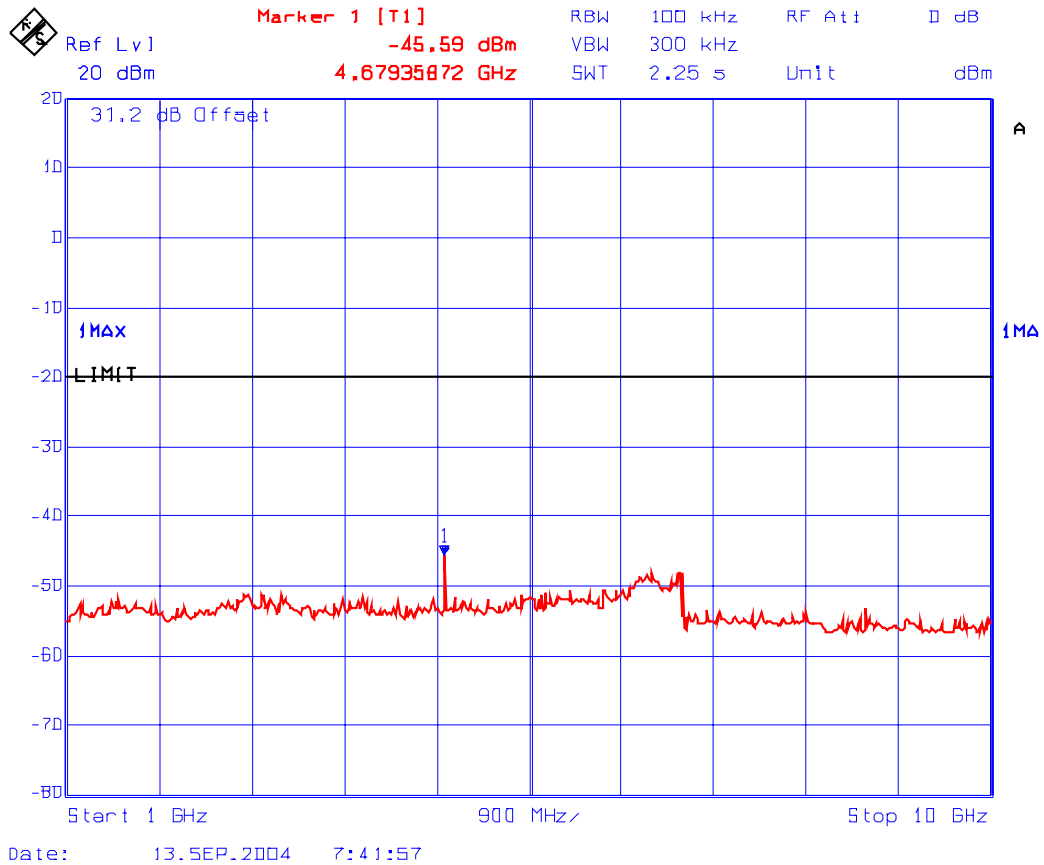

ULTRATECH GROUP OF LABS

3000 Bristol Circle, Oakville, Ontario, Canada L6H 6G4
Tel. #: 905-829-1570, Fax. #: 905-829-8050, Email: vic@ultratech-labs.com, Website: <http://www.ultratech-labs.com>

File #: TXRX-009FCC90

October 14, 2004

All test results contained in this engineering test report are traceable to National Institute of Standards and Technology (NIST)

Fundamental Frequency: 935.0, 935.0125 MHz, (2 channel inputs/outputs)
RF Output Power: 31.4 dBm (conducted)
Modulation: Unmodulated

See the following plots (61 to 62) for details:

**PLOT # 61 Transmitter Conducted Spurious Emissions with 2 RF signal input/output
Fc: 935 MHz, Fc + 12.5 kHz**

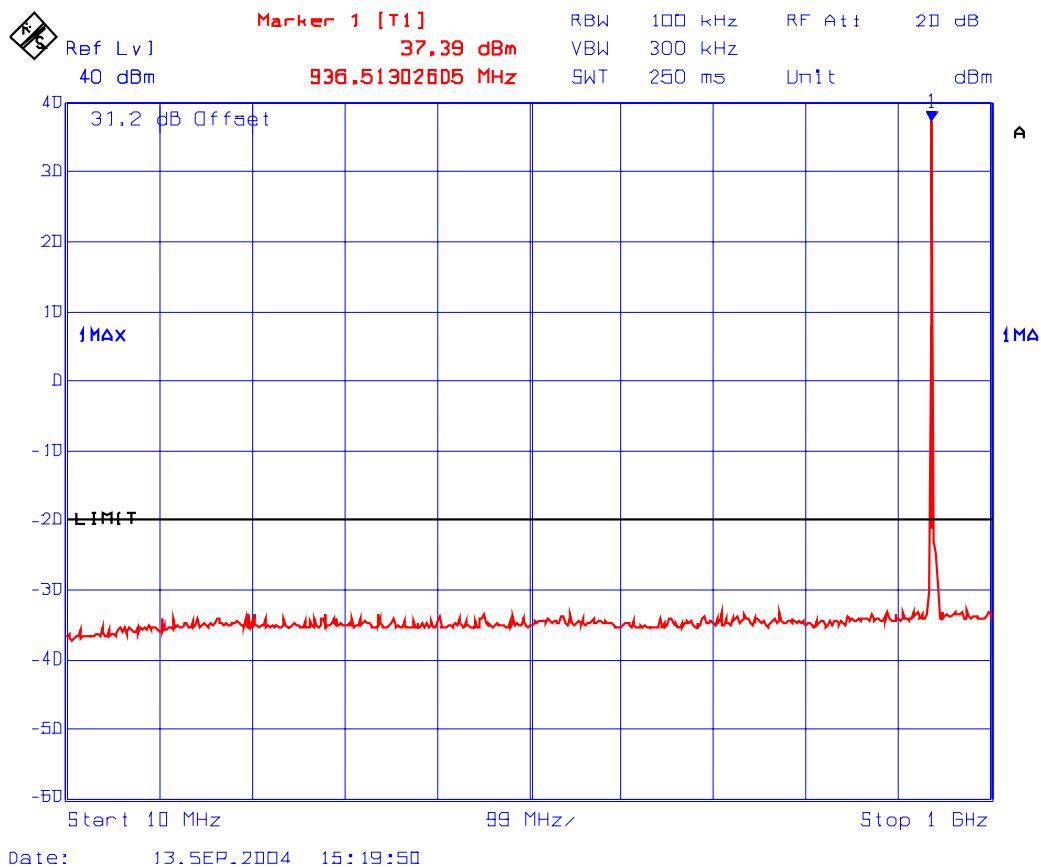

PLOT # 62 Transmitter Conducted Spurious Emissions with 2 RF signal input/output
Fc: 935 MHz, Fc + 12.5 kHz

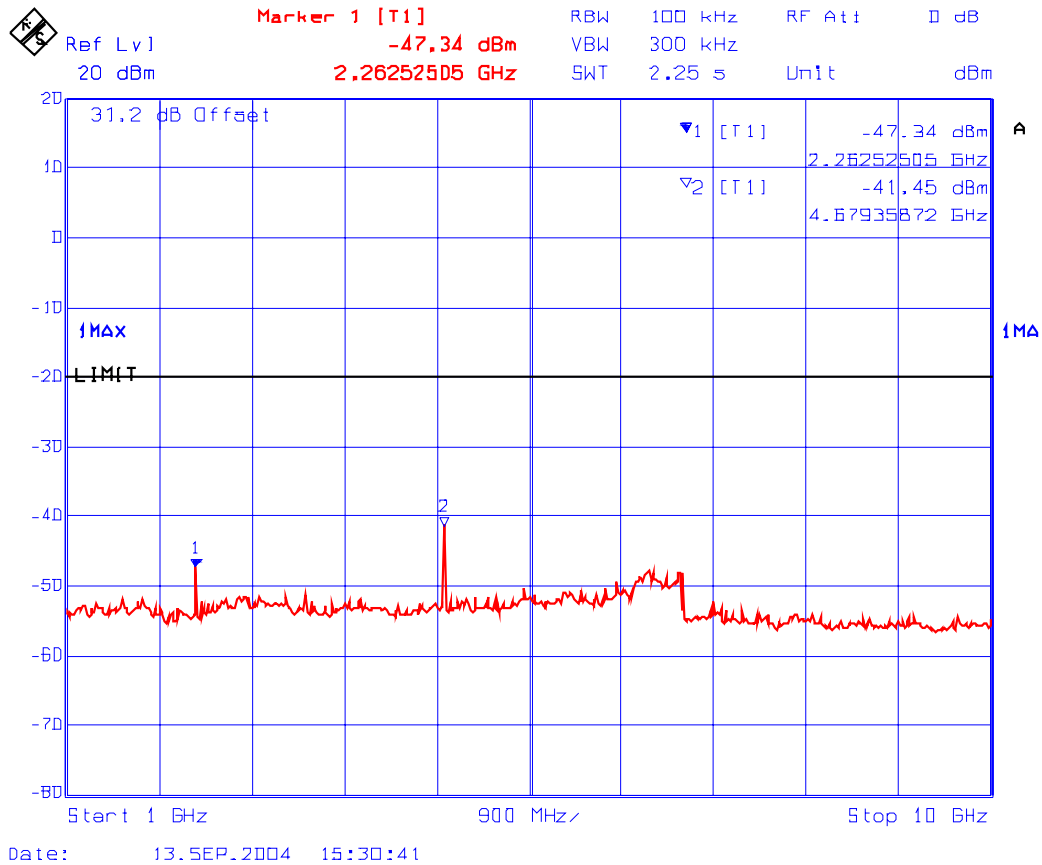

ULTRATECH GROUP OF LABS

3000 Bristol Circle, Oakville, Ontario, Canada L6H 6G4
Tel. #: 905-829-1570, Fax. #: 905-829-8050, Email: vic@ultratech-labs.com, Website: <http://www.ultratech-labs.com>

File #: TXRX-009FCC90

October 14, 2004

All test results contained in this engineering test report are traceable to National Institute of Standards and Technology (NIST)

Fundamental Frequency: 935.0, 935.0125, 935.0250 (3 channel inputs/outputs)
RF Output Power: 28.1 dBm (conducted)
Modulation: Unmodulated

See the following plots (63 to 64) for details:

PLOT # 63 Transmitter Conducted Spurious Emissions with 3 RF signal input/output
Fc: 935 MHz, Fc + 12.5 kHz, Fc + 25 kHz

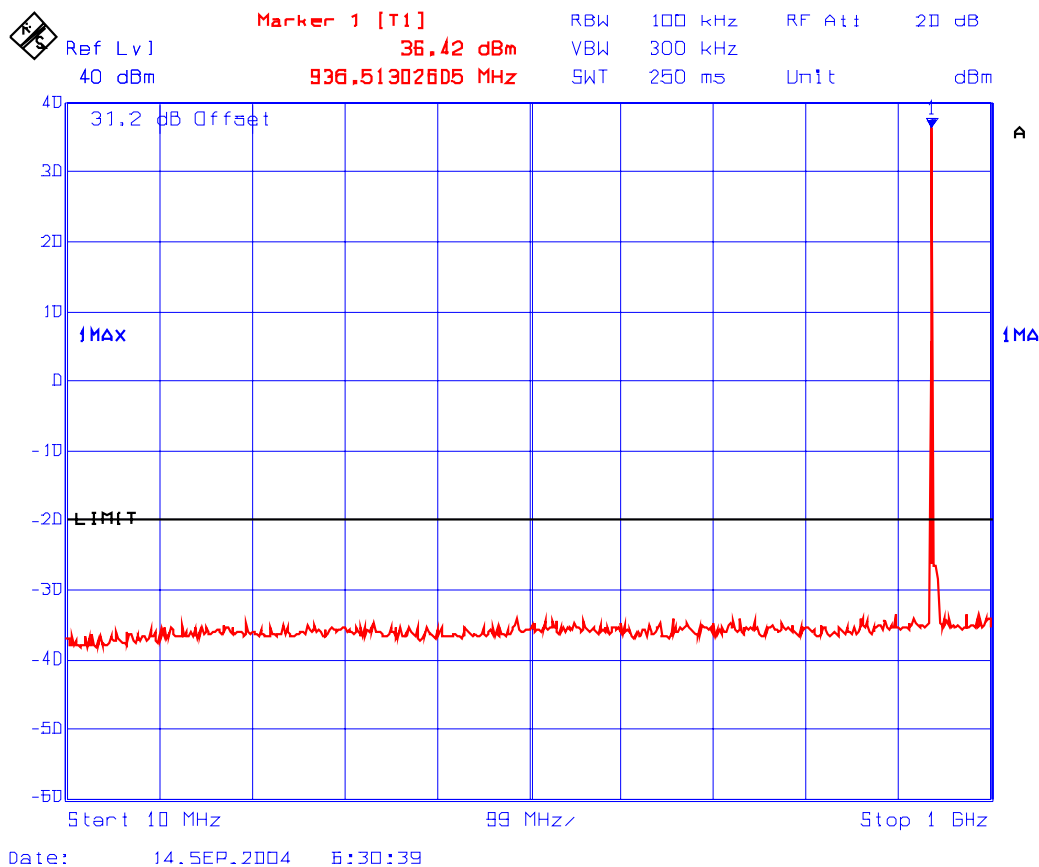

PLOT # 64 Transmitter Conducted Spurious Emissions with 3 RF signal input/output
Fc: 935 MHz, Fc + 12.5 kHz, Fc + 25 kHz

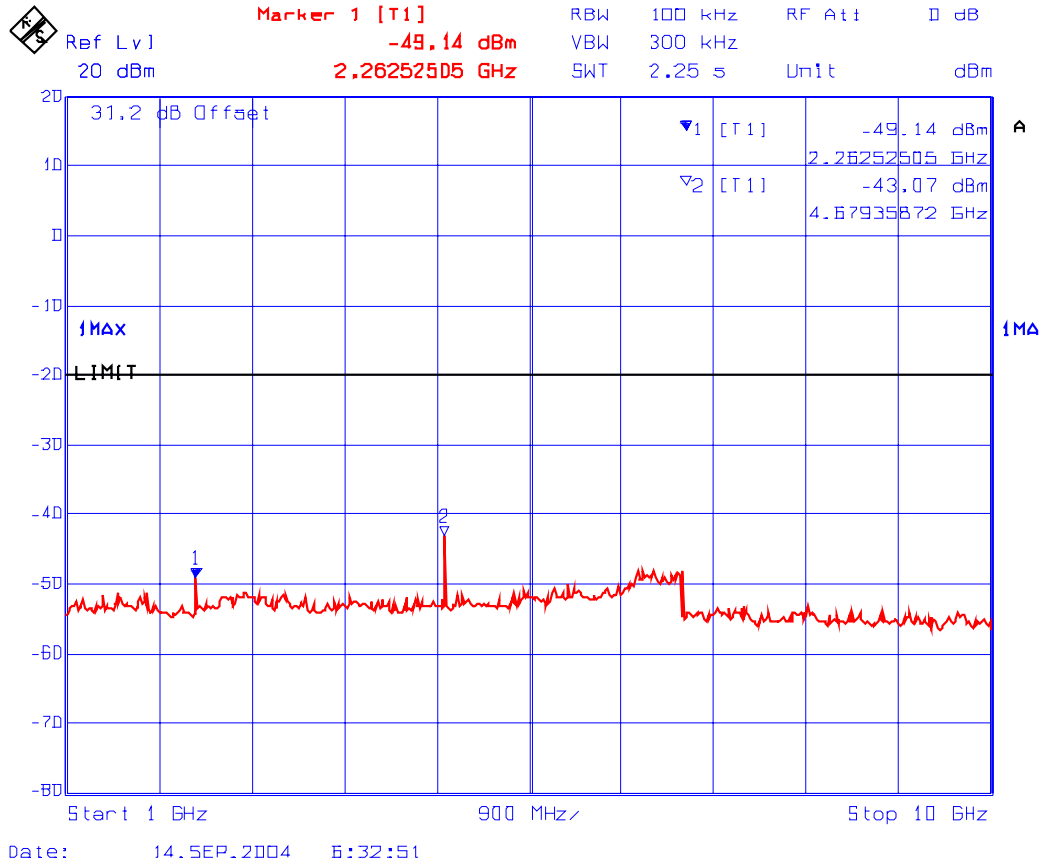

ULTRATECH GROUP OF LABS

3000 Bristol Circle, Oakville, Ontario, Canada L6H 6G4
Tel. #: 905-829-1570, Fax. #: 905-829-8050, Email: vic@ultratech-labs.com, Website: <http://www.ultratech-labs.com>

File #: TXRX-009FCC90

October 14, 2004

All test results contained in this engineering test report are traceable to National Institute of Standards and Technology (NIST)

Fundamental Frequency: 940 MHz, 1 RF Signal input/output
RF Output Power: 35.2 dBm (conducted)
Modulation: Unmodulated

See the following plots (65 to 66) for details:

**PLOT # 65 Transmitter Conducted Spurious Emissions with 1 RF signal input/output
Fc: 940 MHz**

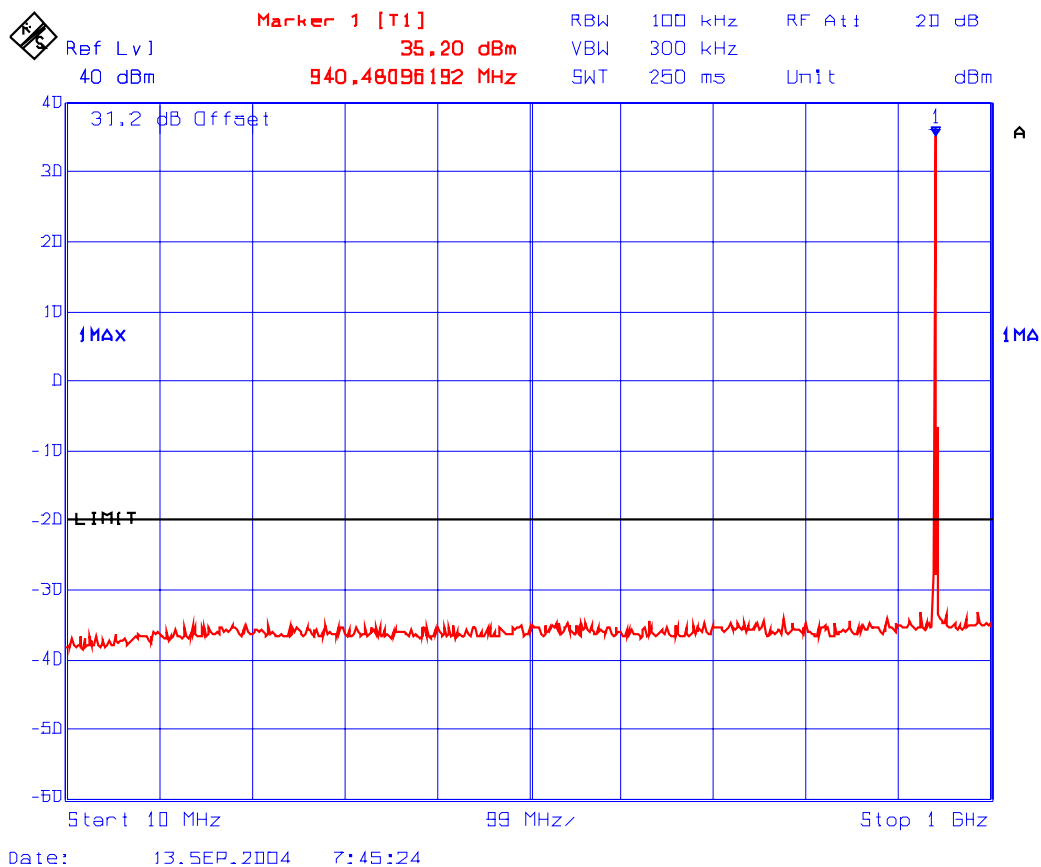

PLOT # 66 Transmitter Conducted Spurious Emissions with 1 RF signal input/output
Fc: 940 MHz

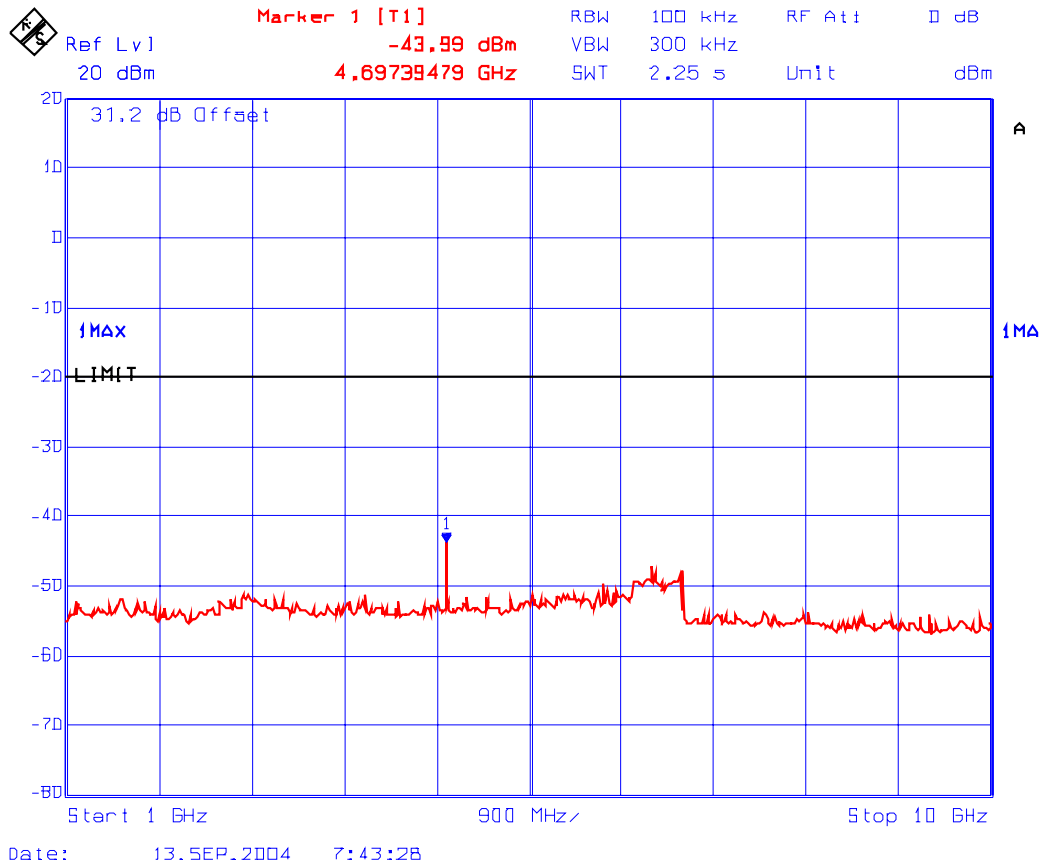

ULTRATECH GROUP OF LABS

3000 Bristol Circle, Oakville, Ontario, Canada L6H 6G4
Tel. #: 905-829-1570, Fax. #: 905-829-8050, Email: vic@ultratech-labs.com, Website: <http://www.ultratech-labs.com>

File #: TXRX-009FCC90

October 14, 2004

All test results contained in this engineering test report are traceable to National Institute of Standards and Technology (NIST)

Fundamental Frequency: 939.9875, 940.0 (2 channel inputs/outputs)
RF Output Power: 31.3 dBm (conducted)
Modulation: Unmodulated

See the following plots (67 to 68) for details:

**PLOT # 67 Transmitter Conducted Spurious Emissions with 2 RF signal input/output
Fc: 940 MHz, Fc -12.5 kHz**

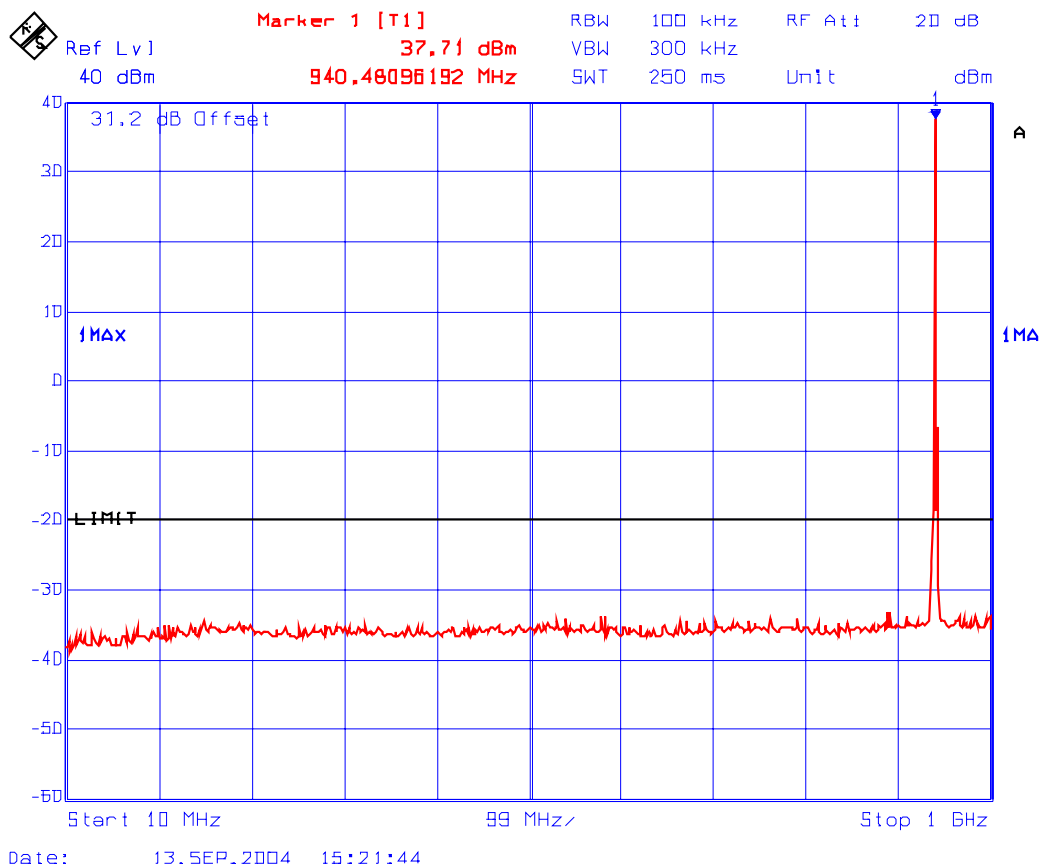

PLOT # 68 Transmitter Conducted Spurious Emissions with 2 RF signal input/output
Fc: 940 MHz, Fc – 12.5 kHz

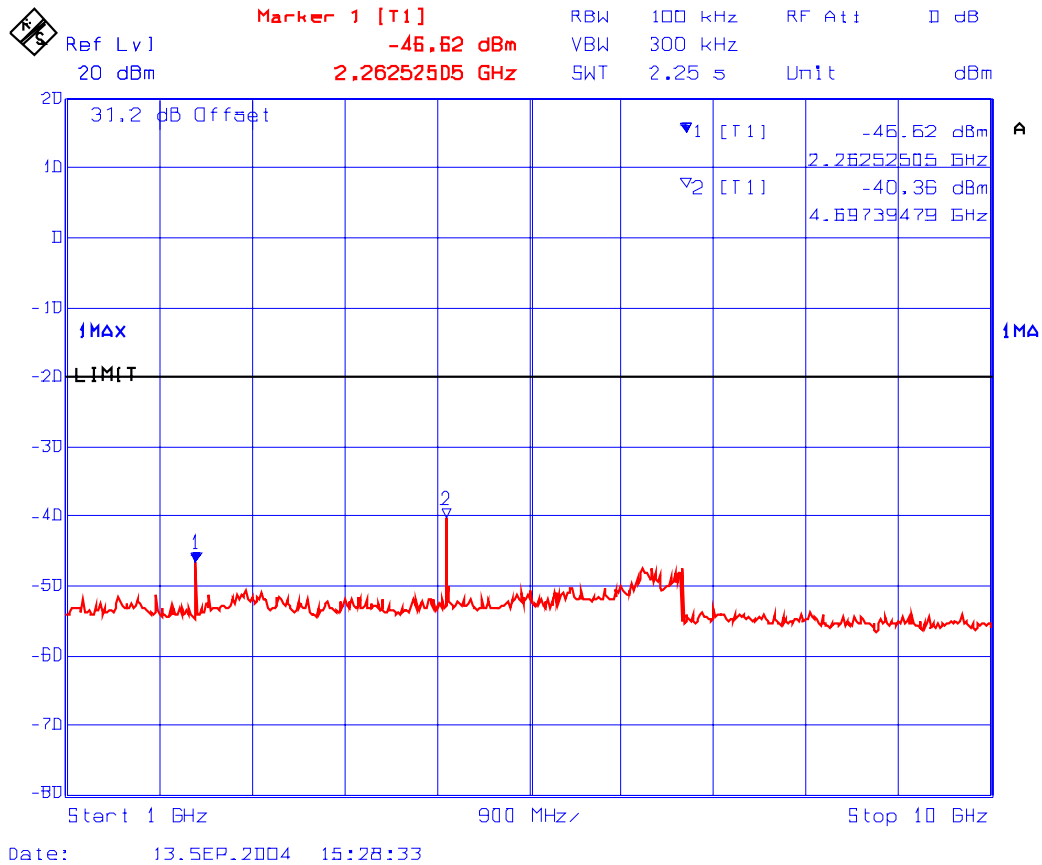

ULTRATECH GROUP OF LABS

3000 Bristol Circle, Oakville, Ontario, Canada L6H 6G4
Tel. #: 905-829-1570, Fax. #: 905-829-8050, Email: vic@ultratech-labs.com, Website: <http://www.ultratech-labs.com>

File #: TXRX-009FCC90

October 14, 2004

All test results contained in this engineering test report are traceable to National Institute of Standards and Technology (NIST)

Fundamental Frequency: 939.975, 939.9875, 940.0 (3 channel inputs/outputs)
RF Output Power: 28.6 dBm (conducted)
Modulation: Unmodulated

See the following plots (69 to 70) for details:

**PLOT # 69 Transmitter Conducted Spurious Emissions with 3 RF signal input/output
Fc: 940 MHz, Fc - 12.5 kHz, Fc - 25 kHz**

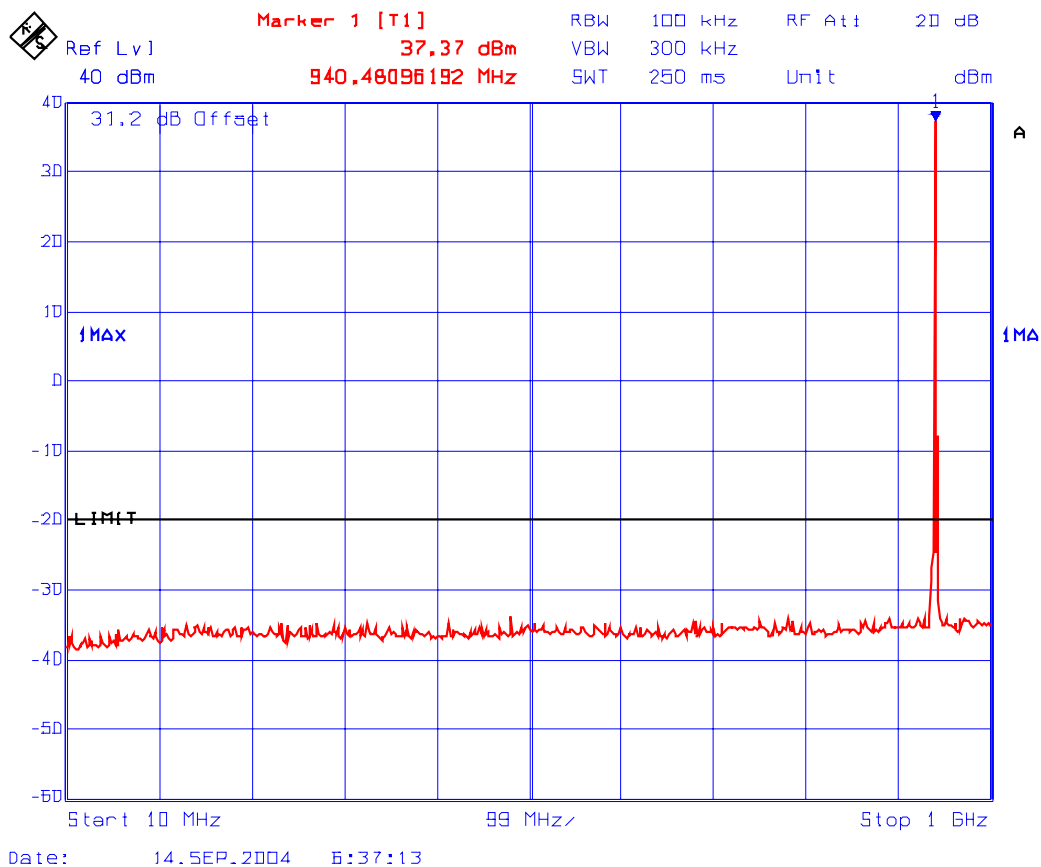

PLOT # 70 Transmitter Conducted Spurious Emissions with 3 RF signal input/output
Fc: 940 MHz, Fc – 12.5 kHz, Fc - 25 kHz



6.9. TRANSMITTER SPURIOUS/HARMONIC RADIATED EMISSIONS [§§ 90.208 & 90.210]

6.9.1. Limits

At least $50 + 10 \cdot \log(P \text{ in Watts})$ dBc.

6.9.2. Method of Measurements

The spurious/harmonic ERP measurements are using substitution method specified in Exhibit 8, Section 8.2 of this report and its value in dBc is calculated as follows:

- (1) If the transmitter's antenna is an integral part of the EUT, the ERP is measured using substitution method.
- (2) If the transmitter's antenna is non-integral and diverse, the lowest ERP of the carrier with 0 dBi antenna gain is used for calculation of the spurious/harmonic emissions in dBc:
 Lowest ERP of the carrier = EIRP – 2.15 dB = $P_c + G - 2.15 \text{ dB} = P_c \text{ dBm (conducted)} + 0 \text{ dBi} - 2.15 \text{ dB}$
- (3) Spurious /harmonic emissions levels expressed in dBc (dB below carrier) are as follows:

$$\text{ERP of spurious/harmonic (dBc)} = \text{ERP of carrier (dBm)} - \text{ERP of spurious/harmonic emission (dBm)}$$

6.9.3. Test Equipment List

Test Instruments	Manufacturer	Model No.	Serial No.	Frequency Range
Spectrum Analyzer	Rohde & Schwarz	FSEK20/B4/B21	834157/005	9 kHz – 40 GHz
RF Amplifier	Com-Power	PA-102		1 MHz to 1 GHz, 30 dB gain nominal
Microwave Amplifier	Hewlett Packard	HP 83017A		1 GHz to 26.5 GHz, 30 dB nominal
Biconilog Antenna	EMCO	3142	10005	30 MHz to 2 GHz
Dipole Antenna	EMCO	3121C	8907-434	30 GHz – 1 GHz
Dipole Antenna	EMCO	3121C	8907-440	30 GHz – 1 GHz
Horn Antenna	EMCO	3155	9701-5061	1 GHz – 18 GHz
Horn Antenna	EMCO	3155	9911-5955	1 GHz – 18 GHz
RF Signal Generator	Hewlett Packard	HP 83752B	3610A00457	0.01 – 20 GHz

6.9.4. Test Data

Remarks:

- (1) There was no difference in spurious/harmonic emissions on pre-scans for all different modulations. Therefore, the rf spurious/harmonic emissions in this section would be performed without modulation and it shall represent for all different modulations required.
- (2) The emissions were scanned from 10 MHz to 10 GHz

6.9.4.1. Band 896-901 MHz

6.9.4.1.1. Lowest Frequency (896 MHz)

Frequency (MHz)	E-Field @3m (dBμV/m)	ERP measured by Substitution Method		EMI Detector (Peak/QP)	Antenna Polarization (H/V)	Limit (dBc)	Margin (dB)	Pass/Fail
		(dBm)	(dBc)					
1792	75.57	-26.47	-61.9	Peak	V	-54.7	-7.2	Pass
1792	73.34	-27.55	-63.0	Peak	H	-54.7	-8.3	Pass
3584	75.08	-28.61	-64.1	Peak	V	-54.7	-9.4	Pass
3584	70.99	-31.90	-67.4	Peak	H	-54.7	-12.7	Pass

The emissions were scanned from 30 MHz to 10 GHz at 3 meters distance and all emissions within 20 dB below the limits were recorded.

6.9.4.1.2. Highest Frequency (901 MHz)

Frequency (MHz)	E-Field @3m (dBμV/m)	ERP measured by Substitution Method		EMI Detector (Peak/QP)	Antenna Polarization (H/V)	Limit (dBc)	Margin (dB)	Pass/Fail
		(dBm)	(dBc)					
1802	76.88	-24.82	-60.1	Peak	V	-54.5	-5.6	Pass
1802	75.61	-25.66	-61.0	Peak	H	-54.5	-6.5	Pass
3604	66.66	-35.49	-70.8	Peak	V	-54.5	-16.3	Pass

The emissions were scanned from 30 MHz to 10 GHz at 3 meters distance and all emissions within 20 dB below the limits were recorded.

6.9.4.2. Band 935-940 MHz

6.9.4.2.1. Lowest Frequency (935 MHz)

Frequency (MHz)	E-Field @3m (dBμV/m)	ERP measured by Substitution Method		EMI Detector (Peak/QP)	Antenna Polarization (H/V)	Limit (dBc)	Margin (dB)	Pass/Fail
		(dBm)	(dBc)					
1870	79.82	-22.12	-57.7	Peak	V	-55.0	-2.7	Pass
1870	72.84	-29.10	-64.7	Peak	H	-55.0	-9.7	Pass
3740	65.76	-36.13	-71.7	Peak	V	-55.0	-16.7	Pass

The emissions were scanned from 30 MHz to 10 GHz at 3 meters distance and all emissions within 20 dB below the limits were recorded.

6.9.4.2.2. Highest Frequency (940 MHz)

Frequency (MHz)	E-Field @3m (dBμV/m)	ERP measured by Substitution Method		EMI Detector (Peak/QP)	Antenna Polarization (H/V)	Limit (dBc)	Margin (dB)	Pass/Fail
		(dBm)	(dBc)					
1880	80.86	-21.08	-56.3	Peak	V	-55.2	-1.1	Pass
1880	79.80	-22.14	-57.4	Peak	H	-55.2	-2.2	Pass
3760	67.89	-34.91	-70.2	Peak	V	-55.2	-15	Pass
3760	64.54	-39.74	-75.0	Peak	H	-55.2	-19.8	Pass
4700	62.49	-39.72	-75.0	Peak	V	-55.2	-19.8	Pass

The emissions were scanned from 30 MHz to 10 GHz at 3 meters distance and all emissions within 20 dB below the limits were recorded.

EXHIBIT 7. MEASUREMENT UNCERTAINTY

The measurement uncertainties stated were calculated in accordance with the requirements of NIST Technical Note 1297 and NIS 81 (1994)

7.1. RADIATED EMISSION MEASUREMENT UNCERTAINTY

CONTRIBUTION (Radiated Emissions)	PROBABILITY DISTRIBUTION	UNCERTAINTY (+ dB)	
		3 m	10 m
Antenna Factor Calibration	Normal (k=2)	± 1.0	± 1.0
Cable Loss Calibration	Normal (k=2)	± 0.3	± 0.5
EMI Receiver specification	Rectangular	± 1.5	± 1.5
Antenna Directivit	Rectangular	+0.5	+0.5
Antenna factor variation with height	Rectangular	± 2.0	± 0.5
Antenna phase center variation	Rectangular	0.0	± 0.2
Antenna factor frequency interpolation	Rectangular	± 0.25	± 0.25
Measurement distance variation	Rectangular	± 0.6	± 0.4
Site imperfections	Rectangular	± 2.0	± 2.0
Mismatch: Receiver VRC $\Gamma_1 = 0.2$ Antenna VRC $\Gamma_R = 0.67(\text{Bi}) 0.3 (\text{Lp})$ Uncertainty limits $20\text{Log}(1 \pm \Gamma_1 \Gamma_R)$	U-Shaped	+1.1 -1.25	± 0.5
System repeatability	Std. Deviation	± 0.5	± 0.5
Repeatability of EUT		-	-
Combined standard uncertainty	Normal	+2.19 / -2.21	+1.74 / -1.72
Expanded uncertainty U	Normal (k=2)	+4.38 / -4.42	+3.48 / -3.44

Calculation for maximum uncertainty when 3m biconical antenna including a factor of k = 2 is used:

$$U = 2u_c(y) = 2x(+2.19) = +4.38 \text{ dB} \quad \text{And} \quad U = 2u_c(y) = 2x(-2.21) = -4.42 \text{ dB}$$

EXHIBIT 8. MEASUREMENT METHODS

8.1. CONDUCTED POWER MEASUREMENTS

- The following shall be applied to the combination(s) of the radio device and its intended antenna(e).
- If the RF level is user adjustable, all measurements shall be made with the highest power level available to the user for that combination.
- The following method of measurement shall apply to both conducted and radiated measurements.
- The radiated measurements are performed at the Ultratech Calibrated Open Field Test Site.
- The measurement shall be performed using normal operation of the equipment with modulation.

Test procedure shall be as follows:

Step 1: Duty Cycle measurements if the transmitter's transmission is transient

- Using a EMI Receiver with the frequency span set to 0 Hz and the sweep time set at a suitable value to capture the envelope peaks and the duty cycle of the transmitter output signal;
- The duty cycle of the transmitter, $x = T_x \text{ on} / (T_x \text{ on} + T_x \text{ off})$ with $0 < x < 1$, is measure and recorded in the test report. For the purpose of testing, the equipment shall be operated with a duty cycle that is equal or more than 0.1.

Step 2: Calculation of Average EIRP. See Figure 1

- The average output power of the transmitter shall be determined using a wideband, calibrated RF average power meter with the power sensor with an integration period that exceeds the repetition period of the transmitter by a factor 5 or more. The observed value shall be recorded as "A" (in dBm);
- The e.i.r.p. shall be calculated from the above measured power output "A", the observed duty cycle x, and the applicable antenna assembly gain "G" in dBi, according to the formula:

$$\text{EIRP} = \text{A} + \text{G} + 10\log(1/x)$$

{ X = 1 for continuous transmission => $10\log(1/x) = 0 \text{ dB}$ }

Figure 1.

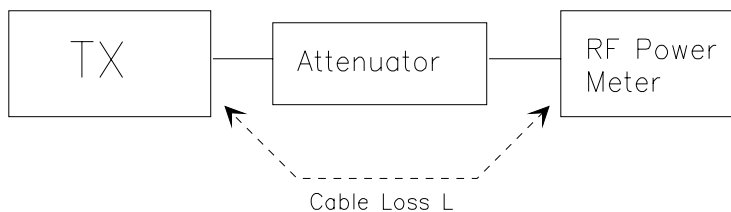

8.2. RADIATED POWER MEASUREMENTS (ERP & EIRP) USING SUBSTITUTION METHOD

8.2.1. Maximizing RF Emission Level (E-Field)

- (a) The measurements was performed with full rf output power and modulation.
- (b) Test was performed at listed 3m open area test site (listed with FCC, IC, ITI, NVLAP, ACA & VCCI).
- (c) The transmitter under test was placed at the specified height on a non-conducting turntable (80 cm height)
- (d) The BICONILOG antenna (20 MHz to 1 GHz) or HORN antenna (1 GHz to 18 GHz) was used for measuring.
- (e) Load an appropriate correction factors file in EMI Receiver for correcting the field strength reading level

Total Correction Factor recorded in the EMI Receiver = Cable Loss + Antenna Factor
 $E \text{ (dBuV/m)} = \text{Reading (dBuV)} + \text{Total Correction Factor (dB/m)}$

- (f) Set the EMI Receiver and #2 as follows:

Center Frequency: test frequency
Resolution BW: 100 kHz
Video BW: same
Detector Mode: positive
Average: off
Span: 3 x the signal bandwidth

- (g) The test antenna was lowered or raised from 1 to 4 meters until the maximum signal level was detected.
- (h) The transmitter was rotated through 360° about a vertical axis until a higher maximum signal was received.
- (i) The test antenna was lowered or raised again from 1 to 4 meters until a maximum was obtained. This level was recorded.
- (j) The recorded reading was corrected to the true field strength level by adding the antenna factor, cable loss and subtracting the pre-amplifier gain.
- (k) The above steps were repeated with both transmitters' antenna and test receiving antenna placed in vertical and horizontal polarization. Both readings with the antennas placed in vertical and horizontal polarization shall be recorded.
- (l) Repeat for all different test signal frequencies

8.2.2. Measuring the EIRP of Spurious/Harmonic Emissions using Substitution Method

(a) Set the EMI Receiver (for measuring E-Field) and Receiver #2 (for measuring EIRP) as follows:

Center Frequency: equal to the signal source
Resolution BW: 10 kHz
Video BW: same
Detector Mode: positive
Average: off
Span: 3 x the signal bandwidth

(b) Load an appropriate correction factors file in EMI Receiver for correcting the field strength reading level

Total Correction Factor recorded in the EMI Receiver = Cable Loss + Antenna Factor
 $E \text{ (dBuV/m)} = \text{Reading (dBuV)} + \text{Total Correction Factor (dB/m)}$

(c) Select the frequency and E-field levels obtained in the Section 8.2.1 for ERP/EIRP measurements.

(d) Substitute the EUT by a signal generator and one of the following transmitting antenna (substitution antenna):

- ◆ DIPOLE antenna for frequency from 30-1000 MHz or
- ◆ HORN antenna for frequency above 1 GHz }.

(e) Mount the transmitting antenna at 1.5 meter high from the ground plane.

(f) Use one of the following antenna as a receiving antenna:

- ◆ DIPOLE antenna for frequency from 30-1000 MHz or
- ◆ HORN antenna for frequency above 1 GHz }.

(g) If the DIPOLE antenna is used, tune it's elements to the frequency as specified in the calibration manual.

(h) Adjust both transmitting and receiving antenna in a VERTICAL polarization.

(i) Tune the EMI Receivers to the test frequency.

(j) Lower or raise the test antenna from 1 to 4 meters until the maximum signal level was detected.

(k) The transmitter was rotated through 360° about a vertical axis until a higher maximum signal was received.

(l) Lower or raise the test antenna from 1 to 4 meters until the maximum signal level was detected.

(m) Adjust input signal to the substitution antenna until an equal or a known related level to that detected from the transmitter was obtained in the test receiver.

(n) Record the power level read from the Average Power Meter and calculate the ERP/EIRP as follows:

$$P = P1 - L1 = (P2 + L2) - L1 = P3 + A + L2 - L1$$

$$EIRP = P + G1 = P3 + L2 - L1 + A + G1$$

$$ERP = EIRP - 2.15 \text{ dB}$$

$$\text{Total Correction factor in EMI Receiver \# 2} = L2 - L1 + G1$$

Where: P: Actual RF Power fed into the substitution antenna port after corrected.

P1: Power output from the signal generator

P2: Power measured at attenuator A input

P3: Power reading on the Average Power Meter

EIRP: EIRP after correction

ERP: ERP after correction

(o) Adjust both transmitting and receiving antenna in a HORIZONTAL polarization, then repeat step (k) to (o)

(p) Repeat step (d) to (o) for different test frequency

(q) Repeat steps (c) to (j) with the substitution antenna oriented in horizontal polarization.

(r) Actual gain of the EUT's antenna is the difference of the measured EIRP and measured RF power at the RF port. Correct the antenna gain if necessary.

Figure 2

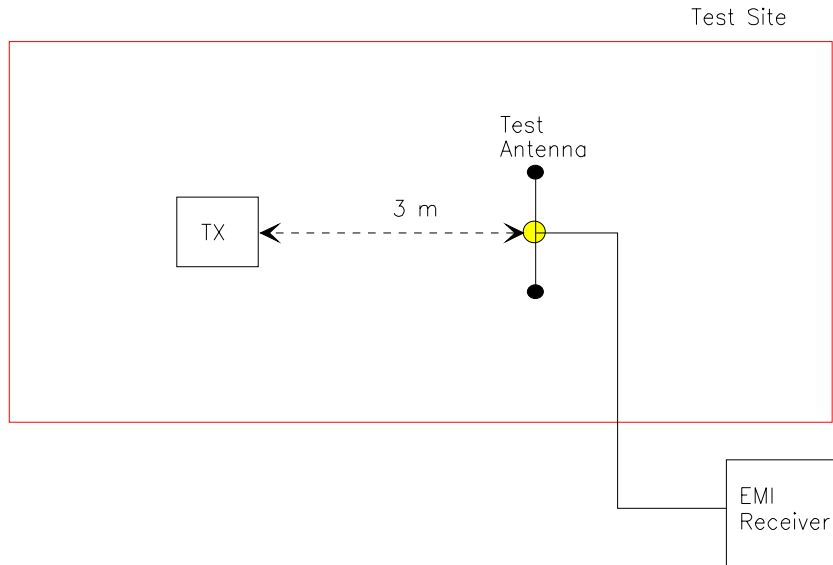
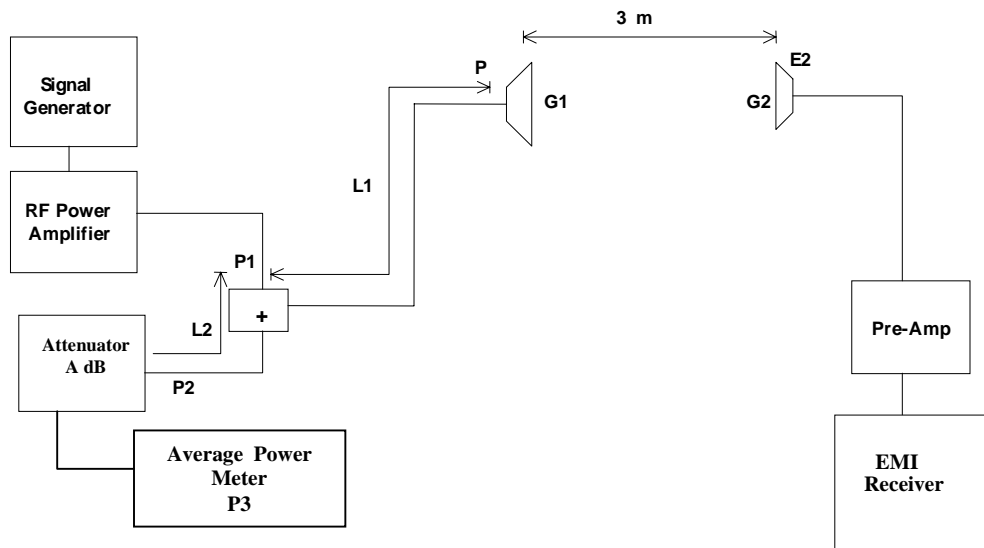

Figure 3



8.3. EMISSION MASK

Voice or Digital Modulation Through a Voice Input Port @ 2.1049(c)(i):- The transmitter was modulated by a 2.5 KHz tone signal at an input level 16 dB greater than that required to produce 50% modulation (e.g.: ± 2.5 KHz peak deviation at 1 KHz modulating frequency). The input level was established at the frequency of maximum response of the audio modulating circuit.

Digital Modulation Through a Data Input Port @ 2.1049(h):- Transmitters employing digital modulation techniques - when modulated by an input signal such that its amplitude and symbol rate represent the maximum rated conditions under which the equipment will be operated. The signal shall be applied through any filter networks, pseudo-random generators or other devices required in normal service. Additionally, the Emission Masks shall be shown for operation with any devices used for modifying the spectrum when such devices are operational at the discretion of the user.

The following EMI Receiver bandwidth shall be used for measurement of Emission Mask/Out-of-Band Emission Measurements:

- (1) For 25 kHz Channel Spacing: RBW = 300 Hz
- (2) For 12.5 kHz or 6.25 kHz Channel Spacings: RBW = 100 Hz

The all cases the Video Bandwidth shall be equal or greater than the measuring bandwidth.

8.4. SPURIOUS EMISSIONS (CONDUCTED)

With transmitter modulation characteristics described in Out-of-Band Emissions measurements @ 2.1049, the transmitter spurious and harmonic emissions were scanned. The spurious and harmonic emissions were measured with the EMI Receiver controls set as RBW = 30 kHz minimum , VBW \geq RBW and SWEEP TIME = AUTO). The transmitter was operated at a full rated power output, and modulated as follows:

FCC CFR 47, Para. 2.1057 - Frequency spectrum to be investigated: - The spectrum was investigated from the lowest radio generated in the equipment up to at least the 10th harmonic of the carrier frequency or to the highest frequency practicable in the present state of the art of measuring techniques, whichever is lower. Particular attention should be paid to harmonics and subharmonics of the carrier frequency. Radiation at the frequencies of multiplier stages should be checked. The amplitude of spurious emissions which are attenuated more than 20 dB below the permissible value need not be reported.

FCC CFR 47, Para. 2.1051 - Spurious Emissions at Antenna Terminal: - The radio frequency voltage or powers generated within the equipment and appearing on a spurious frequency shall be checked at the equipment output terminals when properly loaded with a suitable artificial antenna. Curves or equivalent data shall show the magnitude of the harmonic and other spurious emission that can be detected when the equipment is operated under the conditions specified in 2.1049 as appropriate. The magnitude of spurious emissions which are attenuated more than 20 dB below the permissible value need not be specified.