

Warranty

This warranty applies for one year from shipping date.

TX RX Systems Inc. warrants its products to be free from defect in material and workmanship at the time of shipment. Our obligation under warranty is limited to replacement or repair, at our option, of any such products that shall have been defective at the time of manufacture.

TX RX Systems Inc. reserves the right to replace with merchandise of equal performance although not identical in every way to that originally sold.

TX RX Systems Inc. is not liable for damage caused by lightning or other natural disasters. No product will be accepted for repair or replacement without our prior written approval.

The purchaser must prepay all shipping charges on returned products. **TX RX Systems Inc.** shall in no event be liable for consequential damages, installation costs or expense of any nature resulting from the purchase or use of products, whether or not they are used in accordance with instructions. This warranty is in lieu of all other warranties, either expressed or implied, including any implied warranty or merchantability of fitness. No representative is authorized to assume for **TX RX Systems Inc.** any other liability or warranty than set forth above in connection with our products or services.

Terms and Conditions of Sale

PRICES AND TERMS: Prices are FOB seller's plant in Angola, NY domestic packaging only, and are subject to change without notice. Federal, State and local sales or excise taxes are not included in prices. When Net 30 terms are applicable, payment is due within 30 days of invoice date. All orders are subject to a \$100.00 net minimum.

QUOTATIONS: Only written quotations are valid.

ACCEPTANCE OF ORDERS: Acceptance of orders is valid only when so acknowledged in writing by the seller.

SHIPPING: Unless otherwise agreed at the time the order is placed, seller reserves the right to make partial shipments for which payment shall be made in accordance with seller's stated terms. Shipments are made with transportation charges collect unless otherwise specified by the buyer. Seller's best judgement will be used in routing, except that buyer's routing is used where practicable. The seller is not responsible for selection of most economical or timeliest routing.

CLAIMS: All claims for damage or loss in transit must be made promptly by the buyer against the carrier. All claims for shortages must be made within 30 days after date of shipment of material from the seller's plant.

SPECIFICATION CHANGES OR MODIFICATIONS: All designs and specifications of seller's products are subject to change without notice provided the changes or modifications do not affect performance.

RETURN MATERIAL: Product or material may be returned for credit only after written authorization from the seller, as to which seller shall have sole discretion. In the event of such authorization, credit given shall not exceed 80 percent of the original purchase. In no case will Seller authorize return of material more than 90 days after shipment from Seller's plant. Credit for returned material is issued by the Seller only to the original purchaser.

ORDER CANCELLATION OR ALTERATION: Cancellation or alteration of acknowledged orders by the buyer will be accepted only on terms that protect the seller against loss.

NON WARRANTY REPAIRS AND RETURN WORK: Consult seller's plant for pricing. Buyer must prepay all transportation charges to seller's plant. Standard shipping policy set forth above shall apply with respect to return shipment from TX RX Systems Inc. to buyer.

Disclaimer

Product part numbering in photographs and drawings is accurate at time of printing. Part number labels on TX RX products supercede part numbers given within this manual. Information is subject to change without notice.

Symbols Commonly Used



WARNING



**CAUTION or
ATTENTION**



High Voltage



**Use Safety
Glasses**



**ESD
Electrostatic
Discharge**



Hot Surface



**Electrical Shock
Hazard**



**NOTE
Important
Information**

For Class A Unintentional Radiators

This equipment has been tested and found to comply with the limits for a Class A digital device, pursuant to part 15 of the FCC rules. These limits are designed to provide reasonable protection against harmful interference when the equipment is operated in a commercial environment. This equipment generates, uses, and can radiate radio frequency energy and, if not installed and used in accordance with the instruction manual, may cause harmful interference to radio communications. Operation of this equipment in a residential area is likely to cause harmful interference in which case the user will be required to correct the interference at his own expense.

**WARNING**

Changes or modifications not expressly approved by TX RX System Inc. could void the user's authority to operate the equipment.

This device complies with Part 15 of the FCC Rules. Operation is subject to the following two conditions: (1) this device may not cause harmful interference and (2) this device must accept any interference received, including interference that may cause undesired operation.

**WARNING**

To satisfy FCC RF exposure requirements for transmitting devices, a separation distance of 104 Centimeters or more should be maintained between the UPLINK antenna of this device and persons during device operation. To satisfy FCC RF exposure requirements for transmitting devices, a separation distance of 33 Centimeters or more should be maintained between the DOWNLINK antenna of this device and persons during device operation. To ensure compliance, operations at closer than these distances is not recommended.

The antenna used for this transmitter must not be co-located in conjunction with any other antenna or transmitter.

Antenna System Installation

The antenna or signal distribution system consists of two branches. An uplink branch typically uses an outdoor mounted, unidirectional gain antenna such as a yagi and a downlink signal radiating system consisting of a network of zero-gain whip antennas or lengths of radiating cable usually mounted inside of the structure.

Even though the antenna system may not be supplied or installed by TX RX Systems. The following points need to be observed because both the safety of the user and proper system performance depend on them.

- 1) Antenna system installation should only be performed by qualified technical personnel.
- 2) The following instructions for your safety describe antenna installation guidelines based on FCC Maximum RF Exposure Compliance requirements.
- 3) The uplink antenna is usually mounted outside and exchanges signals with the repeater base station or donor site. It is typically mounted permanently-attached to the building wall or roof. The gain of this antenna should NOT exceed 10 dB. Only qualified personnel should have access to the antenna and under normal operating conditions, no one should be able to touch or approach it within 104 Centimeters (41 inches).
- 4) The downlink or in-building signal distribution system is connected to the downlink booster port using coaxial cable. The distribution system may use radiating coaxial cable or a network 1/4 wave whip antennas whose gain does not exceed 0 dB for any radiator. These antennas should be installed so that the user cannot approach any closer than 33 Centimeters (13 inches) from the antenna.

Table of Contents

General Description	7
Unpacking	7
Installation	7
Location	7
Mounting	8
Connections	8
AC Line	10
Backup DC Power.....	10
Alarm Terminals (Form-C Contacts)	10
RF Connections	11
Pre-RF Connection Testing	11
Test Equipment.....	11
Antenna Isolation.....	11
Procedure for Measuring Antenna Isolation	11
Increase isolation or decrease gain?	12
Normal Operation	12
LED Status Indicators	13
Front Panel LED's	13
Module LED's	13
OLC Light Bars	13
Front Panel Controls & the LCD Display.....	13
LCD Screen	15
Configuration Settings	15
Restore Original Configuration	15
Calibrate Currents	15
Set Gain	15
Set Output Level	15
Change Gain Configuration	15
Detailed Status Screens	16
Amplifiers	16
Power Supply.....	16
OLC	16
OLC Datalog.....	16
Alarms	17
LED Indicators	17
Form-C contacts	17
Performance Survey	18
Maintenance and Repair	18
Power Amplifier Replacement.....	19
Module Replacement.....	20
Display/User Interface Replacement	21
Power Supply Replacement.....	22
Duplexer / Filter Replacement	22
Card Cage Replacement	22
Tuning Instructions.....	22
Test Equipment.....	23
Preselector Tuning	23
Recommended Spares	23

Figures and Tables

Figure 1	Cabinet mounting hole layout	8
Figure 2	Front internal cabinet view	9
Figure 3	AC line entry	10
Figure 4	Connecting the battery backup voltage	10
Figure 5	Measuring antenna isolation	12
Figure 6	Boot-up display	12
Figure 7	Operational status display	13
Figure 8	Menu System	14
Figure 9	Measuring Booster Gain	17
Figure 10	Performance Survey	18
Figure 11	Removing the Power Amplifier (1 of 3)	19
Figure 12	Removing the Power Amplifier (2 of 3)	20
Figure 13	Removing the Power Amplifier (3 of 3)	20
Figure 14	Disconnecting Display/User Interface	21
Figure 15	Preselector Tuning	23
Table 1	Model Number Designations	7
	Specifications	24
	Celsius to Fahrenheit Conversions	25

GENERAL DESCRIPTION

Signal boosters extend radio coverage into areas where abrupt propagation losses prevent reliable communication. No frequency translation (conversion) occurs with this device. Signal Booster II (SB II) is a broadband, bi-directional signal booster available in a variety of configurations as shown in **Table 1**. The product model number is used to describe each configuration available. This manual details the installation and operation of the 61-83B-50-XXX-XX series of boosters.

The system can be ordered in one of three maximum gain configurations including Full Gain (+80 dB gain max), Medium Gain (+60 dB gain max), and Low Gain (+45 dB max gain). The maximum gain of the system is determined by the exact type of cards plugged into the low and mid level slots as shown in the block diagrams at the back of this manual. The maximum gain of the uplink or downlink branch is adjustable and can be setup independently. In addition, the gain of each branch can be reduced up to 30 dB in 0.5 dB increments via software interface.

The bandwidth of the system is determined by the passband of the input/output filtering. The filters passband is determined by its physical construction. Three cabinet styles are available. The G1 suffix denotes a NEMA-4 style cabinet which is suitable for indoor or outdoor use. The G2 suffix denotes a stainless steel NEMA-4X style cabinet suitable for corrosive environments such as salt air and the RM suffix a rack mount version which is intended for indoor mounting only.

UNPACKING

It is important to report any visible damage to the carrier immediately. It is the customer's responsibility to file damage claims with the carrier within a short period of time after delivery (1 to 5 days). Care should be taken when removing the unit from the packing box to avoid damage to external heat-sink fins. Use caution because the heatsink fins can have somewhat sharp corners. Signal Booster II (SB II) weighs about 85 lbs. so use enough people when lifting the unit.

INSTALLATION

The following sections discuss general considerations for installing the booster. All work should be performed by qualified personnel in accordance with local codes.

Location

The layout of the signal distribution system will be the prime factor in determining the mounting location of Signal Booster II. However, safety and serviceability are also key considerations. The unit should be located where it cannot be tampered with by the general public, yet is easily accessible to service personnel. Also consider the weight of the unit and the possibility for injury if the unit should become detached from its mounting surfaces for any reason.

Although signal boosters can operate for years without being attended to, the unit will need to be accessed by service personnel with troubleshooting equipment, such as digital multimeters and

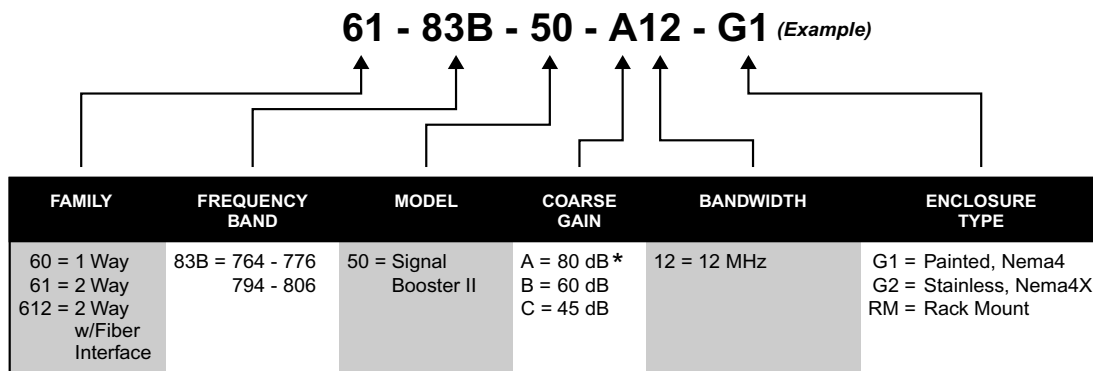

*Note: Gain of 80 dB model set to 50 dB at factory. Please measure antenna isolation before resetting.

Table 1: Model number designations. Model 61-83B-50-A12-G1 shown as example.

spectrum analyzer or a laptop computer from time to time. The location of the power source will also have a bearing on the mounting location. SB II uses external heat sinks and needs to be mounted where there can be an unobstructed air flow over the heat sinks fins. The SB II cabinet will stay warm during normal operation so in the interest of equipment longevity, avoid locations that carry hot exhaust air or are continually hot.

Mounting

Figure 1 shows mounting hole dimensions and layout for the cabinet. Mount the cabinet using 3/8" (10 mm) diameter steel bolts (not supplied). We recommend flat washers on both ends and a lock washer under the nut. Nut and bolt mounting is preferred to the use of lag bolts. Use backer blocks where necessary to spread the force over a larger

surface area. In areas of known seismic activity, additional devices such as tether lines may be necessary.

Because TX RX Systems, Inc. cannot anticipate all the possible mounting locations and structure types where these devices will be located, we recommend consulting local building inspectors, engineering consultants or architects for advice on how to properly mount objects of this type, size and weight in your particular situation. *It is the customer's responsibility to make sure these devices are mounted safely and in compliance with local building codes.*

CONNECTIONS

All cabling connections to the booster should be made and checked for correctness prior to powering up the system.

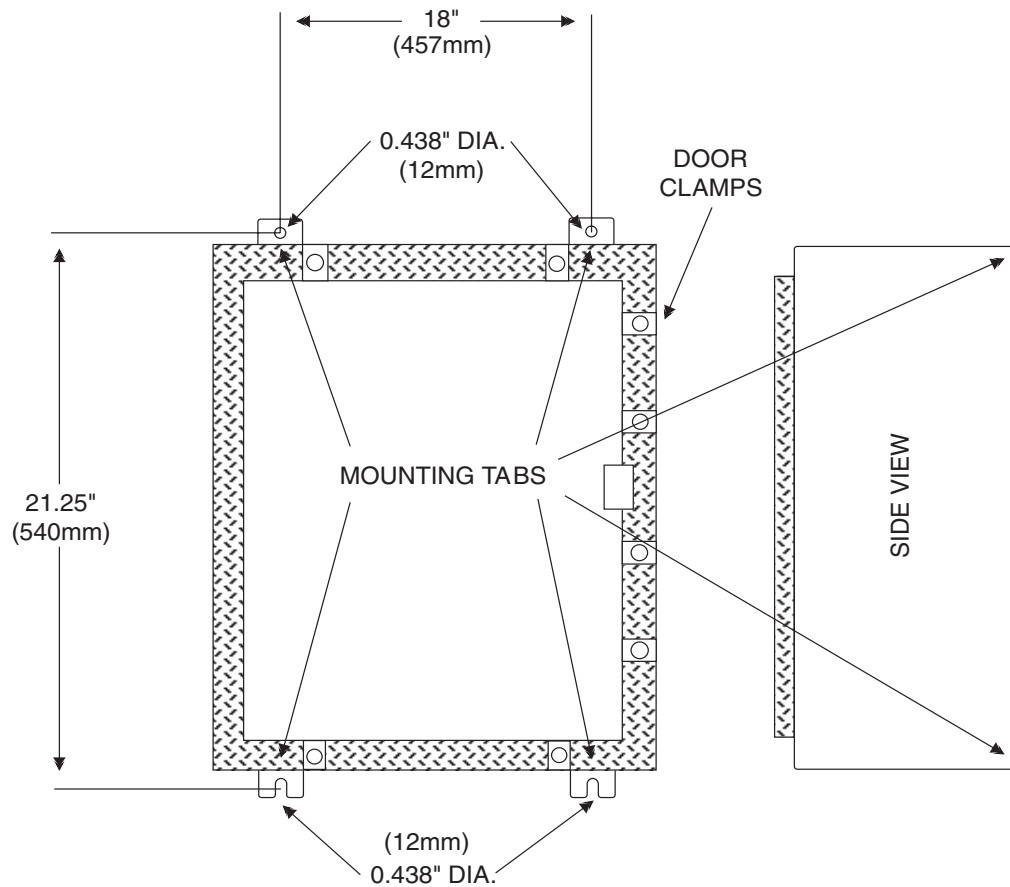

Figure 1: SB II cabinet mounting hole layout.

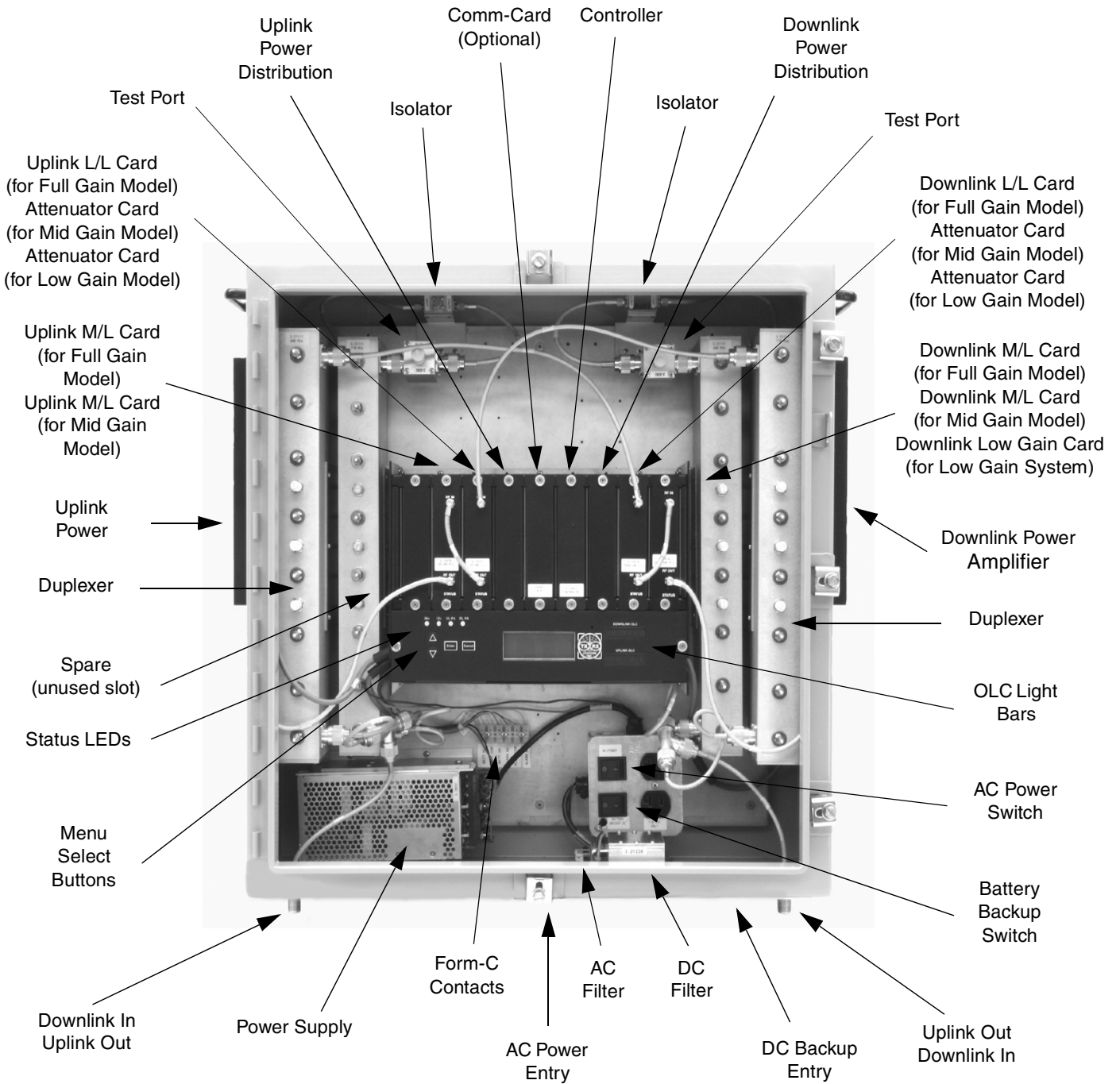

Figure 2: Front view of SB II. Model 61-83B-50-A12-G1 two-way signal booster shown as an example.

AC Line

Signal Booster II is designed to be hard-wired to 110 single phase AC lines at 50 - 60 Hz (see **Figures 2 and 3**). An AC line filter is provided for this purpose. There is a hole provided in the cabinet bottom-wall for bringing in the AC line. Fasten quick connect plugs to each wire of the incoming AC line, then connect the ground wire and hot wire to the respective pins on the top of the AC line filter assembly. Refer to the photo shown in figure 3. The output of the AC line filter is wired into the switch box which also contains a dual convenience outlet for running test equipment. Use conduit for running the AC line into the SBII cabinet and use #14 gauge or large conductors.

Backup DC Power

SB II may be run on a DC power source that can supply 24 to 27 volts DC at 2.5 amps (see **Figures 2 and 4**). This source should be equipped with a fast-acting 3 Amp fuse. A DC line filter is provided for making the connection inside the unit. There is a hole provided in the cabinet bottom-wall for bring-

ing in the DC supply. Fasten spade lugs to each wire of the incoming DC and then connect to the respective pins on the DC line filter assembly. Refer to the photo shown in figure 4. Use #16 or #18 gauge wire for this connection. The power system in SB II automatically switches to this backup DC input when the AC supply fails for any reason including a power outage or intentional disconnection.

It is not necessary that this connection be made for normal operation on the AC line.

Alarm Terminals (Form-C contacts)

Two sets of contacts are provided to monitor the general operating condition of SB II and are intended for connection to a supervisory system. See figure 2.

One set changes state when the AC power supply shuts down for any reason and the unit switches to operation on the backup DC power system. The other set of contacts changes state when any of a number of fault conditions arises within the electronics such as current drain outside of the expected operating range in some module.



Connect incoming AC line to the input lugs of the AC line filter

Figure 3: Wiring of AC line entry.

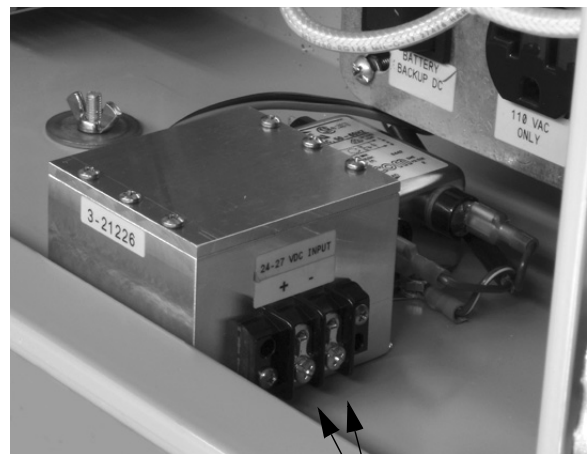

Connect incoming battery backup to the input screws on the DC filter

Figure 4: Battery Backup connections.

A six-terminal strip is provided for the interface and uses screw terminals for ease of connection. Route the alarm wires through one of the access holes in the bottom of the box, strip about 3/16" of insulation from each end, loosen the screw terminal, insert and retighten. Use #20 or #22 gauge insulated wire. Use of these terminals is optional. SB II also has a number of status LEDs built-in to individual modules to indicate a fault condition.

RF Connections

N(F) bulkhead connectors are provided on the bottom of the cabinet for connection to the signal distribution system. Be sure that the correct branch of the distribution system is connected to its corresponding Uplink/Downlink connector or the system will not work properly. Using high-quality connectors with gold center pins is advised. Flexible jumper cables made of high-quality coax are also acceptable for connecting to rigid cable sections.

PRE-RF CONNECTION TESTS

Antenna isolation between the uplink and downlink branches should be measured before connecting the signal booster to the antenna system. This step is necessary to insure that no conditions exist that could possibly damage the signal booster and should not be skipped for even the most thoroughly designed system.



Note: The 80 dB gain models are factory preset to 50 dB gain and should only be reset to a higher value after determining the safe maximum gain based on antenna isolation

Test Equipment

The following equipment is required in order to perform the pre-installation measurements.

- 1) Signal generator for the frequencies of interest capable of a 0 dBm output level. Modulation is not necessary.
- 2) Spectrum analyzer that covers the frequencies of interest and is capable of observing signal levels down to -100 dBm or better.
- 3) Double shielded coaxial test cables made from RG142, RG55 or RG223 coaxial cable.

Antenna Isolation

Just like the feedback squeal that can occur when the microphone and speaker get too close to each other in a public address system, a signal booster can start to self oscillate. This can occur when the isolation between the input antenna or signal source and the output distribution system does not exceed the signal boosters gain by at least 15 dB. Oscillation will reduce the effectiveness of the system and may possibly damage the power amplifier stages.

In general, if one or both antenna ports are connected to sections of radiating coaxial cable (lossy cable) the isolation will be more than adequate because of the high coupling loss values that are encountered with this type of cable. When a network of antennas are used for the input and output, this problem is much more likely. Isolation values are relatively easy to measure with a spectrum analyzer and signal generator.

Procedure for Measuring Antenna Isolation

- 1) Set the signal generator for a 0 dBm output level at the center frequency of one of the signal boosters passbands (770 or 800 MHz)
- 2) Set the spectrum analyzer for the same center frequency and a sweep width equal to or just slightly greater than the passband (12 MHz) chosen in step one.
- 3) Connect the test leads of the signal generator and the spectrum analyzer together using a female barrel connector, see **Figure 5**. Observe the signal on the analyzer and adjust the input attenuator of the spectrum analyzer for a signal level that just reaches the 0 dBm level at the top of the graticule.
- 4) Referring to figure 5, connect the generator test lead to one side of the signal distribution system (external antenna) and the spectrum analyzer lead to the other (internal distribution system) and observe the signal level. The difference between this observed level and 0 dBm is the isolation between the sections. If the signal is too weak to observe, the spectrum analyzer's bandwidth may have to be narrowed and its input attenuation reduced. Record the isolation value. **The isolation value measured should exceed the signal booster's gain figure by at least 15 dB.**

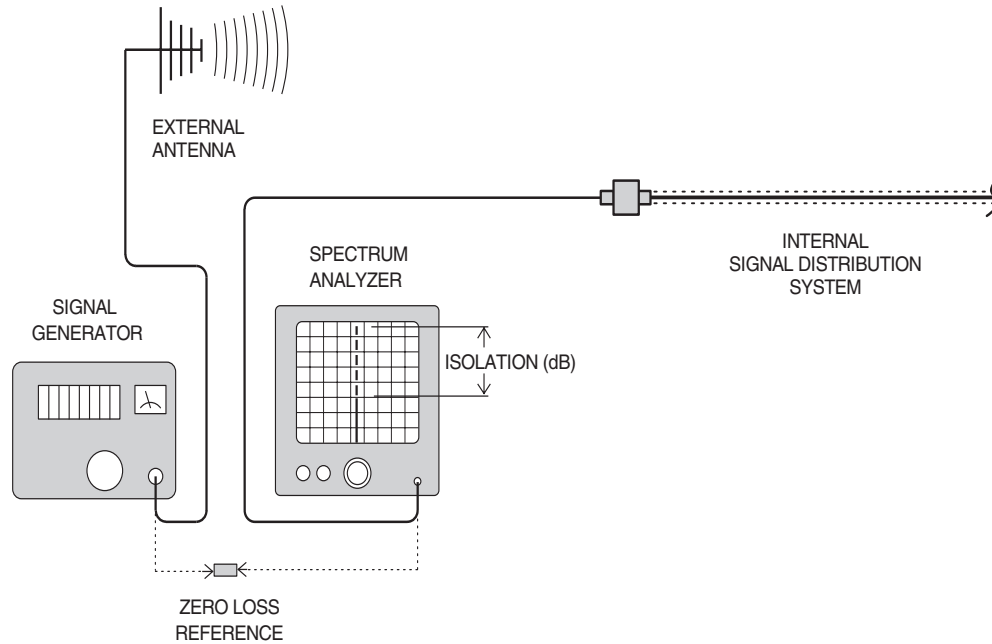

Figure 5: Typical test equipment interconnection for measuring antenna isolation.

It is wise to repeat the procedure listed above for measuring antenna isolation with the signal generator set to frequencies at the passbands edges in order to see if the isolation is remaining relatively constant over the complete width of the passband.

Repeat the isolation measurements at the other passband in bi-directional systems and use the lesser of the two values to determine the maximum gain setting.

Increase Isolation or decrease gain?

Modification of the signal distribution system is required to increase isolation between the up and downlink path. This will require significant changes that may or may not be practical from a cost or logistical standpoint. Gain reduction may be the only alternative but this is easy to achieve with Signal Booster II. Gain for both the uplink and downlink path can be set from 50 to 80 dB. Here are the steps to follow.

- 1) Subtract 15 dB from the measured isolation between uplink and downlink branches of the antenna/signal distribution system. This is the maximum usable gain level for both the uplink and downlink path.

- 2) Accessing the user menu through the front panel, set the gain of the uplink path to the level determined in step 1. A detailed explanation of how to negotiate the menu system is given on page 14.

- 3) Repeat step 2 for the downlink path.

NORMAL OPERATION

Power is applied to the signal booster by turning on the AC power switch located on the junction box inside the cabinet, refer to figure 2. The following startup sequence occurs.

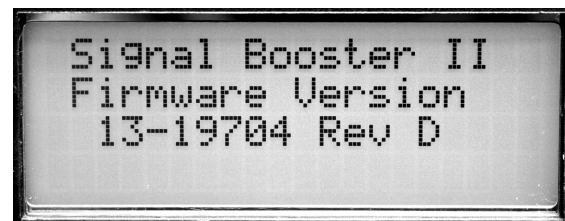

Figure 6: Software version is displayed briefly during the boot-up sequence.

- 1) At turn-on, the four status LEDs on the front panel glow red for about 5 seconds as the result of entering a self-check mode.
- 2) The two green OLC light bars will be fully lit along their length for approximately 5 seconds.
- 3) The LCD display shows the firmware revision screen for about 5 seconds (see **Figure 6**).
- 4) After the self check is complete, the four status lights should turn green and the light bars should be dark unless a signal is activating OLC action in either the uplink or downlink.



If the OLC light-bar segments on both the Uplink and Downlink display light-up and pulse on and off every 1 to 3 seconds simultaneously, **SHUT OFF THE POWER IMMEDIATELY!** The booster may be oscillating. Disconnect the uplink and downlink antenna connections and measure the isolation between the two branches to insure there is sufficient isolation. Reset the booster gain as needed.

- 5) The LCD display should appear similar to **Figure 7** after the self check is complete.

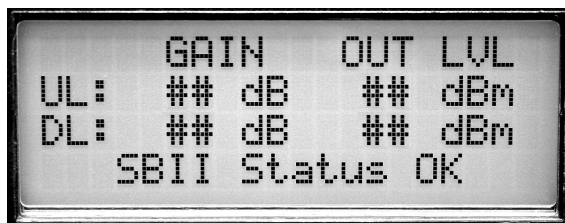

Figure 7: Normal Operational LCD Display.

LED Status indicators

The SB II front panel has 4 status LEDs that glow green or red to indicate the general health of 4 sub-systems from a DC perspective. Additionally, the plug-in, Low-Level and Mid-Level amplifier cards have tri-color (green-orange-red) status LEDs visible when the cabinet door is open.

FRONT PANEL LEDES:

24V: Green indicates the 24 volt DC Power system is operating properly.

12V: Green indicates the 12 volt DC power system is operating properly.

UL PA: Green indicates that the uplink power amplifier is drawing current within the expected operating range and at a safe temperature.

DL PA: Green indicates that the downlink power amplifier is drawing current within the expected operating range and at a safe temperature.

Module LEDES:

Mid-Level, Low-Level, Low Gain Module: Green indicates current or device temperature within the expected operating range. Orange indicates current or temperature slightly out of the expected range but the overall booster operation may still appear normal. Red indicates a large departure from normal current or device temperature and booster operation is likely to be affected. See page 17 for more details about alarm operation.

Attenuator Module: Green only indicating DC power is applied to the card.

OLC LIGHT BARS

Ideally, there should be little or no light bar activity. Each light bar segment represents an average 3 dB of OLC gain reduction. OLC (output level control) is meant to reduce gain for transient episodes of very strong signals. However, when OLC is active, gain is reduced for all signals being processed by that booster branch and that reduction may compromise communications for weaker signals in the booster's passband.

If more than 2 or 3 light-bar segments are lit up more than occasionally, it is advised that the gain of that branch be reduced. See the SET GAIN paragraph on page 15 for details.

Front Panel Controls & the LCD Display

SB II is software directed so control of the system is accomplished via user interface with the control panel using the LCD display screen and the menu select buttons, see figure 2. A flow chart showing all of the possible user menu selections is shown in **Figure 8**.

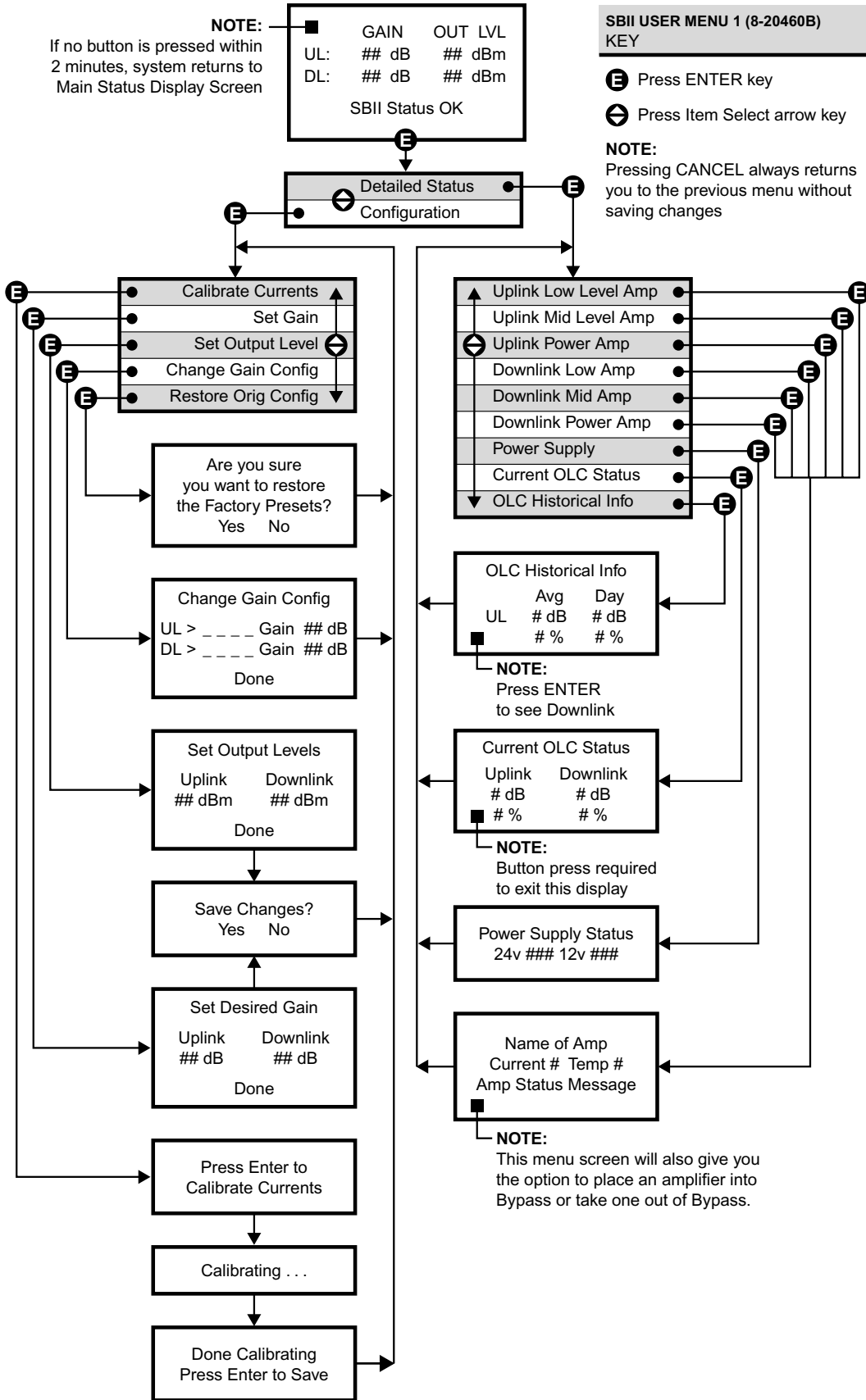

Figure 8: Signal Booster II Menu System.

LCD Screen

Once the boot-up sequence is completed (after several seconds) the LCD screen will switch to the main status display as shown in figure 7. This is the normal display for the signal booster. The system will return to this display from any other display if none of the menu interface buttons are pressed within 2 minutes. The exception is the OLC status display which does require a button press to exit. The main status display shows the uplink and downlink gain in dB as well as the uplink and downlink output level in dBm.

The last line of the main status display gives a summary status message for the entire signal booster. In this example "Status OK" is being displayed. Pressing the "ENTER" button will move you from the main status display into the menu selections and will permit interaction with the system. There are two main functions available within the software menus including configuration settings and detailed status displays.

Configuration Settings

In most cases, the factory default settings are the optimum values for adjustable parameters. The most common setting to be changed by the system's technician is the gain setting. This is normally done to compensate for varying values of antenna isolation as outlined earlier in this manual or to reduce excessive OLC action resulting from excessive gain.

Please thoroughly study this section before making any adjustments to the configuration values. Each configured item is discussed in detail.



Note: Changes to configuration settings do not take affect until the Main Status screen is re-enabled. This occurs automatically after 2 minutes without button input or manually by pressing the Enter/Done/Cancel buttons to return to the status screen.

RESTORE ORIG CONFIG

This command will restore all configured settings to their original factory default values. SB II ships from the factory preset to the lowest gain possible.

CALIBRATE CURRENTS

Use this command when replacing an RF amplifier. This function automatically calibrates the current alarm "trip" point of each amplifier in the system.

Due to manufacturing tolerances there are small differences in current draw between amplifier assemblies. This software function matches the alarm sensing circuit to the respective amplifier assembly and should be repeated whenever an amplifier assembly is replaced.

SET GAIN

This function allows the user to electronically set the gain of the booster in 0.5 dB increments over a range of 30 dB. Gain can be adjusted independently for both the uplink and downlink channels but in most cases both uplink and downlink should be set to the same gain value.

Know your antenna isolation before making this adjustment. We recommend that you temporarily disconnect both the uplink and downlink antennas when setting the gain to avoid the possibility of causing the unit to oscillate. After changing the setting, power the unit down, reconnect the antennas and power-up the booster.



Note: A reduction in system gain will also result in an equal reduction in the OLC dynamic range, refer to the section titled "OLC" on page 16.

SET OUTPUT LEVEL

Allows the output power for the uplink and downlink channels to be independently adjusted in 0.5 dB increments up to +36 dBm. Note that the OLC circuitry will maintain the systems output level at the values you have selected in this menu.

Use this function **ONLY** if your system is causing some form of interference to another radio system. You can only reduce the booster's output power with this command.

CHANGE GAIN CONFIGURATION

Insures proper gain readings when changing basic booster gain by changing the type of plug-in card assemblies.

Use of this menu is **ONLY** needed when converting your stock SB II to a different gain level by changing the low level, mid-level plug-in amplifier card or the addition of an attenuator card. It actually is a change to the characteristics of another model. Don't confuse this with simple amplifier bypassing to reduce gain. Uplink and down link can be set independently. Choices for gain are Full, Mid or

Low and the Enter key toggles the gain setting. The corresponding gain level is displayed. Select Done using the arrow keys and press enter to return to the menu. Use the Cancel button to return to the Status Display.

Detailed Status Screens

These items allow a detailed examination of system components including; all amplifiers (current draw and temperature), the power supply (voltage level), and the OLC function (present status and historical archive). Each item is discussed below in detail.

AMPLIFIERS

A separate status screen is available for each amplifier in the system. When an amplifier is selected this function will display the present current draw of that amp as well as its present operating temperature in degrees Celsius. In addition, a status message will indicate if the amplifier is connected and whether the amplifier is bypassed or not bypassed. This menu selection also provides the option of placing an amplifier in bypass or taking an amplifier out of bypass.

The current draw will be blank if an amplifier is not connected, will display BYP if the amplifier is bypassed, and will display ATTEN if an attenuator card is being used in place of the amplifier card.



The power amplifier currents will normally fluctuate up to 850 ma when signals are present.

POWER SUPPLY

This function displays the real time power supply voltages for both 24 volt and 12 volt supplies.

OLC

This screen shows the amount of attenuation presently being used by the OLC for both the uplink and downlink channels. In addition, the percentage of OLC presently being used is also shown.



The amount of OLC currently being used in either the uplink or downlink channels is also indicated by LED bar graph displays located on the display panel. Each segment represents 2 to 4 dB of attenuation depending on the gain setting of the booster. The OLC bars should only be active

occasionally and no more than 3 or 4 segments briefly lit. Constant light bar activity means the booster gain needs to be reduced for optimum performance.



The system has 60 dB of OLC dynamic range. However, it can be reduced when a portion of the dynamic range is used as fixed attenuation to reduce system gain. The reduction will be an equal amount. For instance, if the gain is reduced by 20 dB then the OLC dynamic range will also be reduced by 20 dB. In the factory, the system gain is allowed to be no more than 3 dB above the minimum levels of 80/60/45 dB. But every amplifier has slightly different gains and some have higher gains than the others. When a system gain is more than 3 dB above the minimum level (due to fluctuation in amplifier gains), part of the OLC dynamic range is programmed during final calibration as fixed attenuation to reduce the system gain. In the field, a user can further adjust the system gain by setting the “user selectable gain” lower and effectively programming more OLC dynamic range into fixed attenuation.

OLC DATALOG

This screen displays an OLC Datalog which is the OLC data over the past 100 days for both uplink and downlink branches of the system. This is a rolling 100 day log with day 101 overlapping day 1 and so forth. Day zero represents the current day while day one represents yesterday and so on. The logged data is stored in non-volatile memory and will not be erased when the unit is powered down.

The average OLC attenuation used when the OLC was active is given both for individual days and over the entire past 100 days. The percentage of time the OLC was active is also given for both individual days and over the past 100 days. This archived information will permit the creation of a user signal profile to facilitate optimum system configuration and performance.

This archive feature will allow you to see if the gain of the unit is set too high or if there are transient episodes of strong signals perhaps desensitizing other channels being amplified by the booster.

Alarms

The system continuously monitors the current draw and operating temperature of each amplifier as well as the voltage level of the +12 and +24 VDC supplies. If any of these parameters exceed normal operating levels by a factory preset percentage the system enters an alarm condition. Notification of an alarm condition is provided by LED indicators and Form-C contacts available via the alarm terminal screws.

LED INDICATORS

There are LED indicators for each amplifier in the system as well as the +12 and +24 VDC power supply voltages. The LED indicators for the low, mid, and low gain amplifiers are located on the individual plug-in module. These are tri-color LED's with green representing NORMAL operation, orange representing a WARNING condition, and red indicating a FAULT. A warning condition occurs when the current draw of the amplifier exceeds nominal by +/- 20%. Fault conditions occur when the current draw exceeds +/- 30% or the amplifiers operating temperature exceeds 80° Celsius. The LED for the attenuator card is green only and indicates DC power applied to the card.

The LED indicators for the power amplifiers are located on the display panel next to the menu select buttons and are dual color LED's. Green represents NORMAL operation while red indicates a FAULT condition. Fault conditions occur when the current draw exceeds 900 ma or falls below 200 ma. Also, whenever the amplifiers operating temperature exceeds 95° Celsius. The power amplifiers do not have a warning state.

The power supply LED indicators are located on the display panel next to the menu selection buttons and are also dual color. Green representing normal operation and red a fault condition. A fault condition for the +24 VDC supply occurs whenever the voltage potential drops below +16 VDC (30% below nominal). Likewise, a fault for the +12 VDC supply occurs when the potential is below +8 VDC (30% below nominal).

FORM-C CONTACTS

Form-C contacts are available inside the cabinet next to the power supply assembly, see figure 2. These screw terminals are intended for connection to the customers supervisory alarm or data acquisition system. One set of terminals supplies notifica-

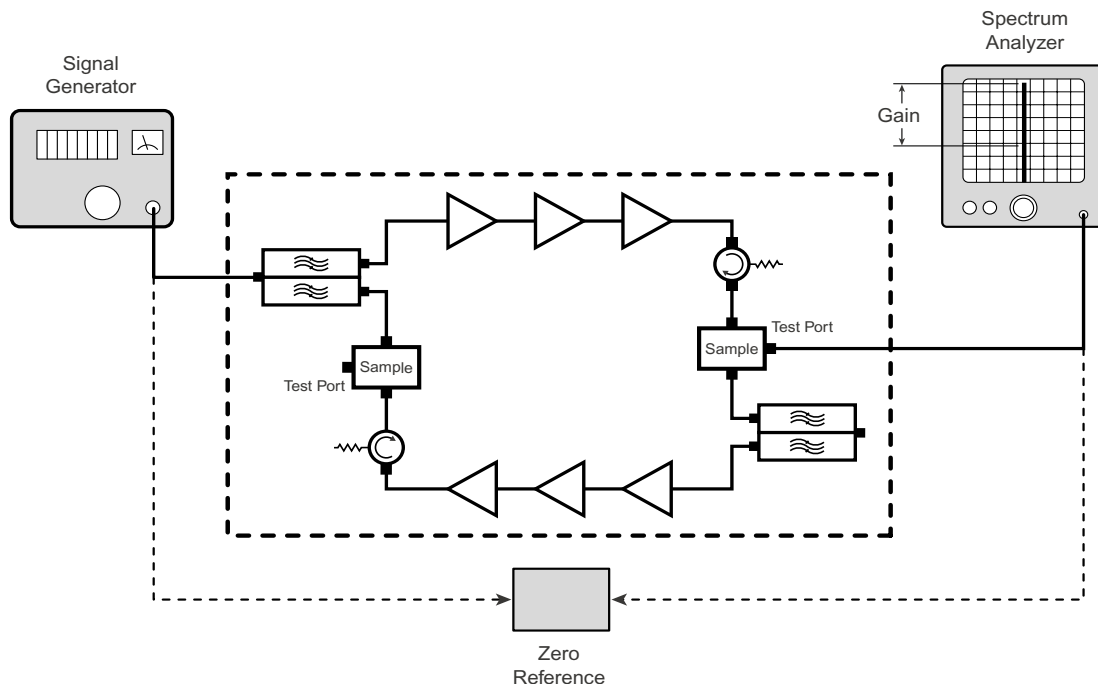

Figure 9: Measuring signal booster gain.

tion of any alarm condition occurring and the second set of contacts indicate the system is operating on battery backup power.

PERFORMANCE SURVEY

It is a good idea to document the performance of the system after installation so that a reference exists for future comparisons. This information can make troubleshooting an interference problem or investigation of a complaint about system performance much easier. If there are coverage problems with a system, this survey will usually reveal them allowing corrective measures to be taken before the system is put into routine use. The following is an outline of how to do such a survey. Because the nature of each installation can be quite different, only a broad outline is given.

- 1) Measure the gain of the signal booster being careful not to exceed the maximum input level. **Figure 9** shows this being done using a signal generator and spectrum analyzer. Record the measured values for each passband. We recommend that a 50 ohm load be connected to the unused RF port on the bottom of the cabinet during the gain test.

- 2) The spectrum analyzer is connected to the -30 dB signal sampler port following the final output amp. This port will allow the observation of the amplifier output at a considerably reduced output level. This decoupling value (-30 dB) needs to be added to any measured signal value in order to arrive at the actual signal level.
- 3) With a spectrum analyzer connected to the signal sampler port (see **Figure 10**), have personnel with handheld radios move to several predetermined points and key their radios. Record the level of these signals as observed on the analyzer and also record the location of the person transmitting. In this way, a map of the systems performance can be generated.
- 4) For signals coming from a fixed antenna or station, record the level of all the desired incoming signals for future reference.

MAINTENANCE AND REPAIR

Signal boosters manufactured by TX RX Systems, Inc. can perform for years with little maintenance and repair. However, if the amplifiers are subjected to excessively high signal levels, power surges or

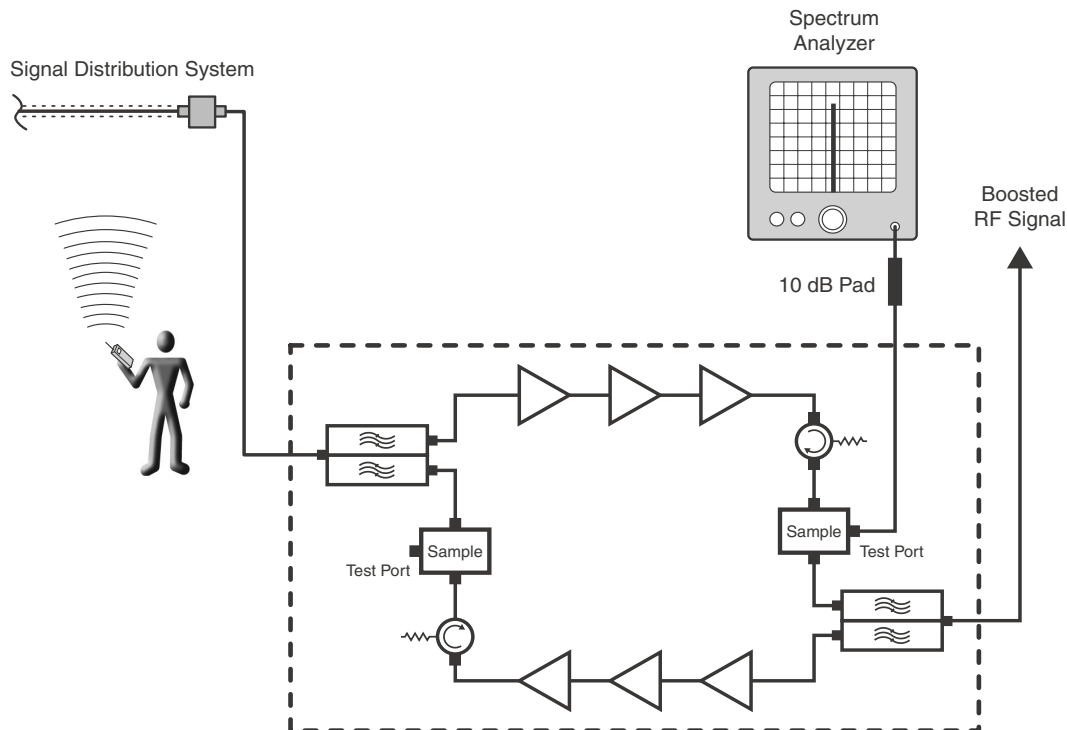

Figure 10: Methodology for doing a performance survey of the signal distribution system.

lightning strikes, failures may occur. The following procedures may be followed for detecting a malfunctioning unit or as part of a periodic maintenance program.

- 1) The heatsink area should be cleared of dust and debris.
- 2) Inspect the unit to see that the two power supply LED DC indicators are lit (remove any dust or debris that may obscure the LEDs). This will verify that DC power is flowing properly. Check all hardware for tightness.
- 3) Compare system performance to initial performance levels measured when the system was first installed. The lack of signal can be traced to a malfunctioning amplifier by progressive signal monitoring from the output (far end) to the input end of the system noting the area where the signal returns to normal level. The next

amplifier toward the output end of the system will probably be the one that failed.

or

Measure the gain at any convenient frequency in the working frequency band to verify that the performance is still within specifications.

Power Amplifier Replacement

The SB II power amplifiers are field replaceable. Follow the steps listed below in sequential order. The required tools are a #1 Phillips screwdriver and a 5/16" open-ended wrench.



Note: Power to the SB II cabinet must be turned OFF during the power amplifier replacement process.

- 1) Remove the Phillips screws which hold the amplifier into place, refer to **Figure 11**. The nuts holding the screws are pressed into the cabinet

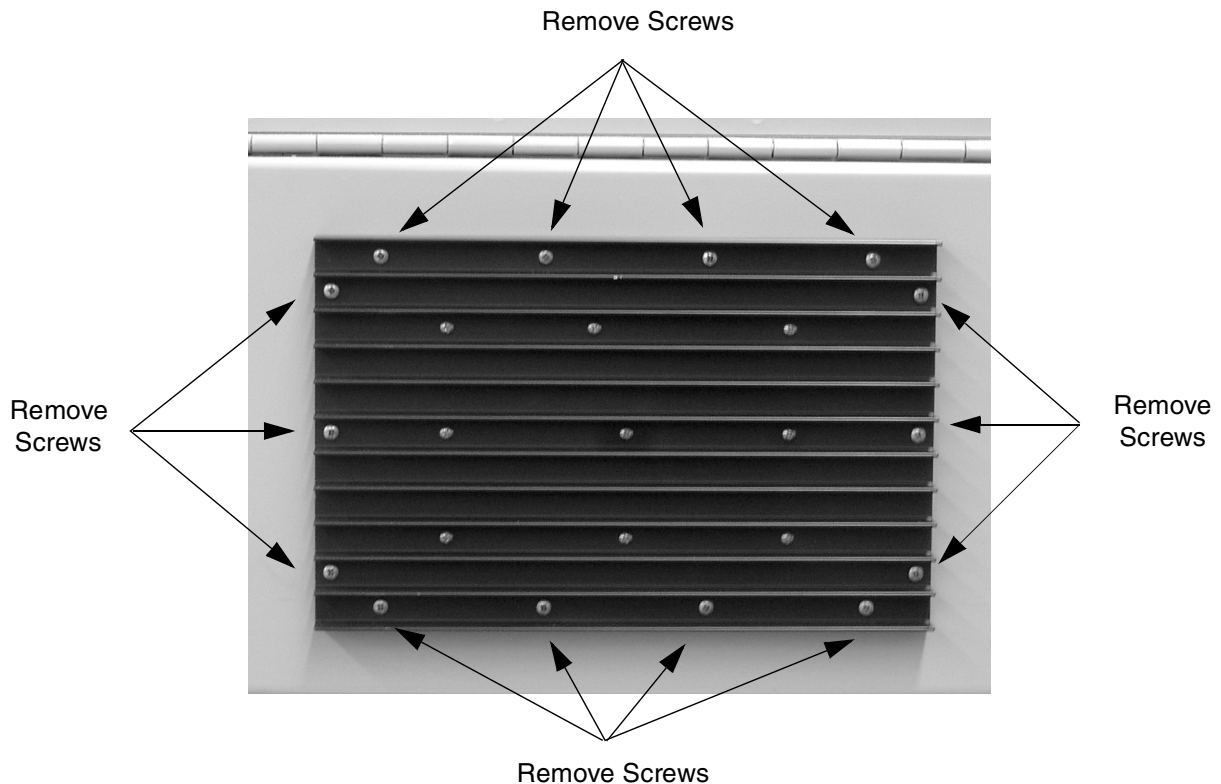

Figure 11: Remove 14 mounting screws to detach amplifier assembly from cabinet.



Figure 12: Slide amplifier towards bottom of cabinet to remove upper cable.

and will remain in place when the screws are removed.

- 2) Slide the amplifier towards the bottom of the cabinet as far as it will go. This will allow the top RF connector to clear the opening. Tilt the top of the amplifier outwards and remove the top RF cable at the SMA connector using the 5/16" wrench. See **Figure 12**.
- 3) Slide the amplifier assembly towards the top of the cabinet as far as it will go. This will allow the bottom RF connector and grey control cable to clear the opening. Tilt the bottom of the amplifier outwards and remove the bottom RF cable at the SMA connector and the grey control cable. To remove the grey cable from the socket on the amplifier it is necessary to squeeze the top and bottom of the connector together to release a hold down tab. When properly squeezed the grey cable will disconnect easily from the amplifier. Refer to **Figure 13**.
- 4) To replace the amplifier assembly repeat steps 1 through 3 in reverse order. When replacing the RF cables do not overtighten the SMA con-

nectors. They should be tightened just slightly more than hand tight or to the specification of 7 in/lbs. The replacement amplifier comes with an attached gasket which must press up against the outside of the cabinet firmly and squarely in order to provide a correct moisture seal.

Module Replacement

The SB II modules are field replaceable. Follow the steps listed below in sequential order. The required tools are a #1 Phillips screwdriver. Two thumb screws hold each module into place.



Note: Power to the SB II cabinet must be turned OFF during the module replacement process except for the amplifier modules which are "HOT" switchable.

- 1) Loosen the two thumb screws which hold the module into place. Phillips screws are incorporated into the thumbscrews and they may need to be loosened first.
- 2) Grasping the two loosened thumb screws pull the module straight out of the card cage.
- 3) To install the replacement module place the module into the guide-rails of the slot and press down firmly into place. Each type of module is keyed uniquely to fit in only one slot within the



Figure 13: Slide amplifier towards top of cabinet to remove lower cables.

card cage. Once the card is seated into place properly tighten the thumb screws.

The SB II low level and mid level amplifier stages are field replaceable by simply removing the module and plugging in a replacement. These modules are HOT switchable meaning they can be swapped without powering down the system. RF cables attached to the modules must be removed (5/16" wrench) prior to swapping the modules and must be re-attached after the new module is in place. when replacing the RF cables do not overtighten the SMA connectors. They should be tightened just slightly more than hand tight or to the specification of 7 in/lbs.

Modules can be swapped between the uplink and downlink branches for troubleshooting purposes. If a problem exists in one branch and the problem moves to the other branch when modules are swapped around this indicates a defective module.



Note: After an amplifier module is replaced use the Calibrate Currents software function to properly set the amplifiers alarm trip point, see page 10. Due to slight differences in component tolerances the trip point must be reset for any new amplifier assemblies introduced into the system.

Display/User Interface Assembly Replacement

The SB II Display/User Interface assembly is field replaceable. Follow the steps listed below in sequential order. No tools are required.



Note: Power to the SB II cabinet must be turned OFF during the display/user interface replacement process.

- 1) Loosen the two thumb-nuts which hold the display/user interface assembly to the card cage.

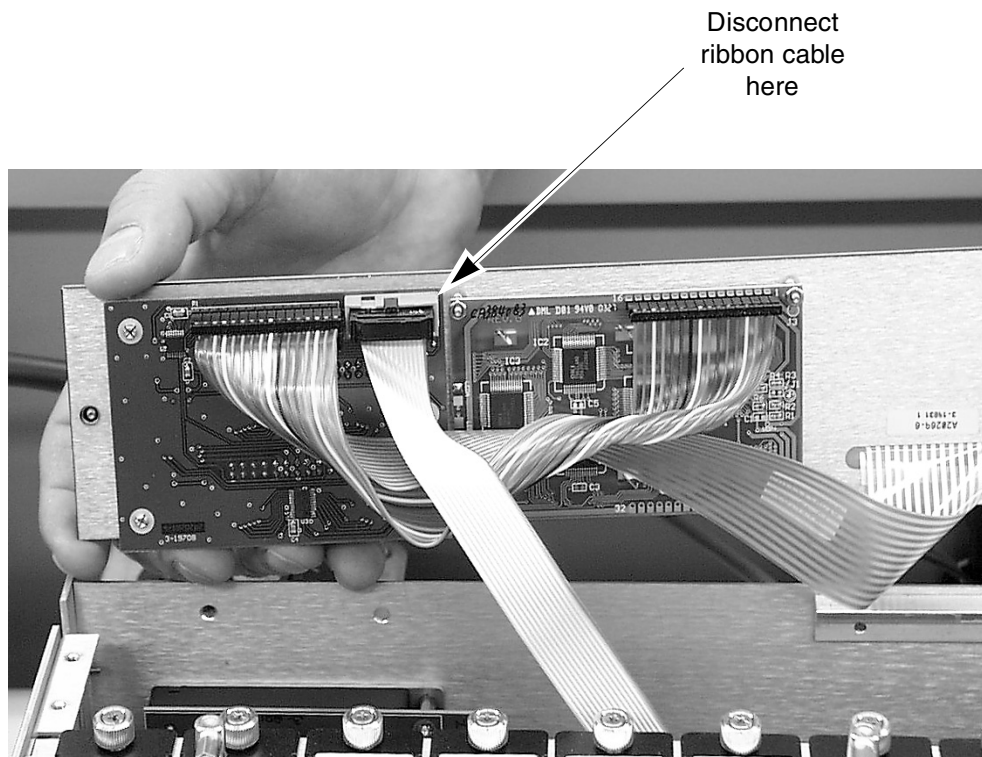

Figure 14: Disconnecting the display/user interface assembly from the card cage.

- 2) Gently tilt only the top of the assembly up from the card cage. Keep the bottom of the assembly in place. The bottom mounting plate (part of the card cage) has an overhang on it to support the display/user interface board. If the assembly is lifted straight out the overhang it could possibly damage the interface circuit board.
 - 3) With the display/user interface board standing up straight gently move it upwards while lifting it out about an inch or two. This should allow the overhang to clear the interface circuit board without damage.
 - 4) Remove the ribbon cable that connects the display/user interface assembly to the card cage, see **Figure 14**.
 - 5) To replace the display/user interface assembly repeat steps 1 through 4 in reverse order.
- 1) All RF cables attached to the assembly must be removed (5/16" wrench).
 - 2) Remove the Phillips screws that hold the assembly mount brackets to the back plate and remove the assembly from the cabinet.
 - 3) Reverse steps 2 and 1 to install the replacement filter. When replacing the RF cables do not overtighten the SMA connectors. They should be tightened just slightly more than hand tight or to the specification of 7 in/lbs.

Card Cage Replacement

To replace the card cage follow the steps listed below in sequential order. The required tools are a #1 Phillips screwdriver with an extended shaft to reach down far enough into the unit to loosen the mounting screws.



Note: Power to the SB II cabinet must be turned OFF during the card cage replacement process.

Power Supply Replacement

The SB II power supply assembly is field replaceable. Follow the steps listed below in sequential order. The required tools are a #1 Phillips screwdriver.

- 1) Turn off AC power at the junction box.
- 2) Disconnect the 3 conductor cable that brings AC power to the supply from the junction box.
- 3) Disconnect the red and black leads from the power supply that connect to the card cage.
- 4) Remove the Phillips screws that hold the power supply mount bracket to the back plate and remove the assembly from the cabinet.
- 5) Reverse steps 4 through 2 to install the replacement power supply.

- 1) Disconnect the display/user interface assembly.
- 2) Disconnect 4 cables at the backplane of the card cage which are assessable with the display/user interface board out of the way.
- 3) Remove the row of Phillips screws which hold the card cage to the back plate. There is a row of screws at the top and bottom of the cage.
- 4) To install a replacement cage perform steps 3 through 1 in reverse order.

Duplexer / Filter Replacement

The filter assemblies are field replaceable. Follow the steps listed below in sequential order. The required tools are a #1 Phillips screwdriver with an extended shaft to reach down far enough into the unit to loosen the mounting screws.



Note: Power to the SB II cabinet must be turned OFF during the filter replacement process.

Tuning Instructions

Tuning instructions are provided in support of field service activities. It is assumed that the procedures listed in this manual will be carried out by a qualified electronics technician observing all standard safety practices.

The amplifier assemblies used in the model 61-83B-50-XXX-XX signal boosters are of sufficient bandwidth to cover the entire range of operation. Tuning is not required. The individual filters used in the duplexer are passive devices of rugged electrical and mechanical design. They are tuned at the factory for the original design requirements and require no adjustment or maintenance. These devices will stay properly tuned unless they have

been physically damaged or are tampered with. Combine preselector filters provide the input and output selectivity for the system. These filters have a carefully shaped response curve that passes a number of contiguous communication channels with each filter designed to cover a 12 MHz bandwidth.

TEST EQUIPMENT

A two channel network analyzer that simultaneously displays both transmission and reflection is best for properly tuning a preselector. A single channel tracking generator/spectrum analyzer combination may be adequate but is not accurate enough to verify factory specifications. A return loss bridge would also be required when using a tracking generator. Skill and experience are also needed and the personnel doing the work should be thoroughly familiar with the use of the network

analyzer. A Hewlett Packard 8752B or equivalent network analyzer is recommended.

PRESELECTOR TUNING

The following is a general outline of the tuning procedure.

- 1) Connect test equipment as shown in **Figure 15**.
- 2) Set the analyzer to the desired center frequency and desired bandwidth.
- 3) Loosen the tuning rod locking nuts.
- 4) If the preselector is severely out of tune, set the analyzer for 10 dB/div vertical scale on the transmission channel and alternately adjust the tuning rods in pairs working from the center to the end rods for maximum signal at the center frequency. Note that for preselectors with an odd number of rods, start with the center rod and then move to the pairs, one on either side of center.
- 5) Repeat step 4 tuning to maximize the signal at the center frequency. The response should start to take on the desired shape and symmetry. Setup the analyzer for 1 dB/div (2 dB/div for a tracking generator) on the transmission channel and then re-adjust the rods in the same fashion. Make sure that the return loss curve meets or exceeds the published specification over the range and is relatively symmetrical. Fine adjust the tuning rods to adjust symmetry.
- 7) Lock all tuning rods after the desired response is obtained. Note that a slight dissymmetry in either the transmission or reflection response may be unavoidable.

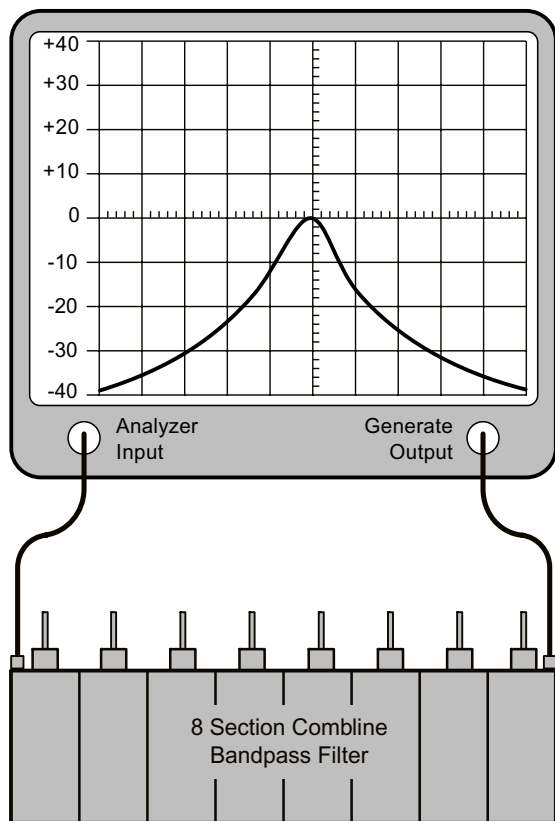

Figure 15: Preselector Tuning.

RECOMMENDED SPARES

It is recommended that one spare of each of the following assemblies be kept on hand for emergency repair purposes; Power Supply 8-20667, Uplink Power Amplifier 3-21121, Downlink Power Amplifier 3-2119, Mid Level Amplifier Card 3-19576, Low Level Amplifier Card 3-19575, Low Gain Amplifier Card 3-20294, Attenuator Card 3-20208, Power Distribution Card 3-19833, Controller Card 3-19832, and the Display/User Interface Assembly 3-19831.

	Low Gain Model	Mid Gain Model	High Gain Model
Maximum Gain:	+45 dB	+60 dB	+80 dB
Gain Adjustment:	Programmable attenuation, 0-30 dB, 0.5 dB steps	Programmable attenuation, 0-30 dB, 0.5 dB steps	Programmable attenuation, 0-60 dB, 0.5 dB steps
3rd Order Output Intercept Point:	+55 dBm minimum, with no attenuation	+55 dBm minimum, with no attenuation	+55 dBm minimum, with no attenuation
RF Sampler:	PA Output sampler ports	PA Output sampler ports	PA Output sampler ports
Noise Figure (without attenuation):	6.5 dB maximum	3.5 dB maximum	3.5 dB maximum,
Operating Temperature Range:	-30°C to +50° C	-30°C to +50° C	-30°C to +50° C
Nominal Impedance:	50 ohms, <1.5:1 VSWR	50 ohms, <1.5:1 VSWR	50 ohms, <1.5:1 VSWR
Input/Output Connectors:	N female	N female	N female
RF Sampler Connectors:	BNC female	BNC female	BNC female
AC Power Input:	100-240 VAC; 50-60 Hz	100-240 VAC; 50-60 Hz	100-240 VAC; 50-60 Hz
DC Input Voltage:	+24 to +27 VDC	+24 to +27 VDC	+24 to +27 VDC
Unit Power Consumption (AC/DC):	<150 VA	<150 VA	<150 VA
Housing:	NEMA 4, NEMA 4X Rack Mount	NEMA 4, NEMA 4X Rack Mount	NEMA 4, NEMA 4X Rack Mount
Nominal Size:	24" x 24" x 8"	24" x 24" x 8"	24" x 24" x 8"
Net Weight:	< 85 lbs.	< 85 lbs.	< 85 lbs.

CELSIUS TO FAHRENHEIT CONVERSION TABLE

CELSIUS	FAHRENHEIT
105	221.0
104	219.2
103	217.4
102	215.6
101	213.8
100	212.0
99	210.2
98	208.4
97	206.6
96	204.8
95	203.0
94	201.2
93	199.4
92	197.6
91	195.8
90	194.0
89	192.2
88	190.4
87	188.6
86	186.8
85	185.0
84	183.2
83	181.4
82	179.6
81	177.8
80	176.0
79	174.2
78	172.4
77	170.6
76	168.8
75	167.0
74	165.2
73	163.4
72	161.6
71	159.8
70	158.0
69	156.2
68	154.4
67	152.6

CELSIUS	FAHRENHEIT
66	150.8
65	149.0
64	147.2
63	145.4
62	143.6
61	141.8
60	140.0
59	138.2
58	136.4
57	134.6
56	132.8
55	131.0
54	129.2
53	127.4
52	125.6
51	123.8
50	122.0
49	120.2
48	118.4
47	116.6
46	114.8
45	113.0
44	111.2
43	109.4
42	107.6
41	105.8
40	104.0
39	102.2
38	100.4
37	98.6
36	96.8
35	95.0
34	93.2
33	91.4
32	89.6
31	87.8
30	86.0
29	84.2
28	82.4

CELSIUS	FAHRENHEIT
27	80.6
26	78.8
25	77.0
24	75.2
23	73.4
22	71.6
21	69.8
20	68.0
19	66.2
18	64.4
17	62.6
16	60.8
15	59.0
14	57.2
13	55.4
12	53.6
11	51.8
10	50.0
9	48.2
8	46.4
7	44.6
6	42.8
5	41.0
4	39.2
3	37.4
2	35.6
1	33.8
0	32.0
-1	30.2
-2	28.4
-3	26.6
-4	24.8
-5	23.0
-6	21.2
-7	19.4
-8	17.6
-9	15.8
-10	14.0
-11	12.2

CELSIUS	FAHRENHEIT
-12	10.4
-13	8.6
-14	6.8
-15	5.0
-16	3.2
-17	1.4
-18	-0.4
-19	-2.2
-20	-4.0
-21	-5.8
-22	-7.6
-23	-9.4
-24	-11.2
-25	-13.0
-26	-14.8
-27	-16.6
-28	-18.4
-29	-20.2
-30	-22.0
-31	-23.8
-32	-25.6
-33	-27.4
-34	-29.2
-35	-31.0
-36	-32.8
-37	-34.6
-38	-36.4
-39	-38.2
-40	-40.0
-41	-41.8
-42	-43.6
-43	-45.4
-44	-47.2
-45	-49.0
-46	-50.8
-47	-52.6
-48	-54.4
-49	-56.2
-50	-58.0