

ENGINEERING TEST REPORT

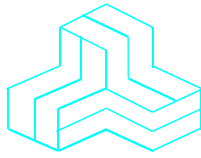

Signal Booster II
Model No.: 61-83B-50
FCC ID: EZZ5PI618350

Applicant:

TX RX Systems, Inc.
8625 Industrial Parkway
Angola, NY 14006
USA

Tested in Accordance With

Federal Communications Commission (FCC)
47 CFR, Parts 2 and 90 (Subpart R)

UltraTech's File No.: TXRX-013F90R

This Test report is Issued under the Authority of
Tri M. Luu, Professional Engineer,
Vice President of Engineering
UltraTech Group of Labs

Date: October 5, 2005



Report Prepared by: Dan Huynh

Tested by: Hung Trinh and Wayne Wu

Issued Date: October 5, 2005

Test Dates: August 9 - 22, 2005

- *The results in this Test Report apply only to the sample(s) tested, and the sample tested is randomly selected.*
- *This report must not be used by the client to claim product endorsement by NVLAP or any agency of the US Government.*

UltraTech

3000 Bristol Circle, Oakville, Ontario, Canada, L6H 6G4
Tel.: (905) 829-1570 Fax: (905) 829-8050

Website: www.ultratech-labs.com, Email: vic@ultratech-labs.com, Email: tri@ultratech-labs.com



TABLE OF CONTENTS

EXHIBIT 1.	SUBMITTAL CHECK LIST	1
EXHIBIT 2.	INTRODUCTION.....	2
2.1.	SCOPE	2
2.2.	RELATED SUBMITTAL(S)/GRANT(S).....	2
2.3.	NORMATIVE REFERENCES	2
EXHIBIT 3.	PERFORMANCE ASSESSMENT	3
3.1.	CLIENT INFORMATION.....	3
3.2.	EQUIPMENT UNDER TEST (EUT) INFORMATION.....	3
3.3.	EUT'S TECHNICAL SPECIFICATIONS.....	4
3.4.	LIST OF EUT'S PORTS.....	5
3.5.	ANCILLARY EQUIPMENT.....	5
3.6.	GENERAL TEST SETUP.....	5
EXHIBIT 4.	EUT OPERATING CONDITIONS AND CONFIGURATIONS DURING TESTS.....	6
4.1.	CLIMATE TEST CONDITIONS	6
4.2.	OPERATIONAL TEST CONDITIONS & ARRANGEMENT FOR TEST SIGNALS	6
EXHIBIT 5.	SUMMARY OF TEST RESULTS.....	7
5.1.	LOCATION OF TESTS.....	7
5.2.	APPLICABILITY & SUMMARY OF EMC EMISSION TEST RESULTS.....	7
5.3.	MODIFICATIONS INCORPORATED IN THE EUT FOR COMPLIANCE PURPOSES.....	8
EXHIBIT 6.	MEASUREMENTS, EXAMINATIONS & TEST DATA FOR EMC EMISSIONS	9
6.1.	TEST PROCEDURES	9
6.2.	MEASUREMENT UNCERTAINTIES	9
6.3.	MEASUREMENT EQUIPMENT USED	9
6.4.	ESSENTIAL/PRIMARY FUNCTIONS AS DECLARED BY THE MANUFACTURER	9
6.5.	RF POWER OUTPUT & INTERMODULATION [§§ 2.1046 & 90.541].....	10
6.6.	RF EXPOSURE REQUIREMENTS [§§ 1.1310 & 2.1091].....	31
6.7.	OCCUPIED BANDWIDTH [§ 2.1049]	35
6.8.	SPURIOUS EMISSIONS AT ANTENNA TERMINAL [§§ 2.1051 & 90.543(c)]	76
6.9.	FIELD STRENGTH OF SPURIOUS EMISSIONS [§§ 2.1053 & 90.543(c)]	113
EXHIBIT 7.	MEASUREMENT UNCERTAINTY.....	116
7.1.	RADIATED EMISSION MEASUREMENT UNCERTAINTY	116
EXHIBIT 8.	MEASUREMENT METHODS.....	117
8.1.	CONDUCTED POWER MEASUREMENTS	117
8.2.	RADIATED POWER MEASUREMENTS (ERP & EIRP) USING SUBSTITUTION METHOD.....	118

EXHIBIT 1. SUBMITTAL CHECK LIST

Annex No.	Exhibit Type	Description of Contents	Quality Check (OK)
--	Test Report	<ul style="list-style-type: none"> • Exhibit 1: Submittal check lists • Exhibit 2: Introduction • Exhibit 3: Performance Assessment • Exhibit 4: EUT Operation and Configuration during Tests • Exhibit 5: Summary of test Results • Exhibit 6: Measurement Data • Exhibit 7: Measurement Uncertainty 	OK
1	Test Setup Photos	Radiated Emission Setup Photos	OK
2	External Photos of EUT	External Photos	OK
3	Internal Photos of EUT	Internal Photos	OK
4	Cover Letters	<ul style="list-style-type: none"> • Letter from Ultratech for Certification Request • Letter from the Applicant to appoint Ultratech to act as an agent • Letter from the Applicant to request for Confidentiality Filing 	OK
5	Attestation Statements	N/A	N/A
6	ID Label/Location Info	ID Label and Location of ID Label	OK
7	Block Diagrams	Block Diagrams	OK
8	Schematic Diagrams	Schematics	OK
9	Parts List/Tune Up Info	Parts List/ Tuning Procedures	OK
10	Operational Description	Operational Description	OK
11	RF Exposure Info	See Section 6.6 of this test report for MPE evaluation	OK
12	Users Manual	Installation and Setup Manual for the Two-Way Signal Booster System	OK

ULTRATECH GROUP OF LABS

3000 Bristol Circle, Oakville, Ontario, Canada L6H 6G4
 Tel. #: 905-829-1570, Fax. #: 905-829-8050, Email: vic@ultratech-labs.com, Website: <http://www.ultratech-labs.com>

File #: TXRX-013F90R
 October 5, 2005

All test results contained in this engineering test report are traceable to National Institute of Standards and Technology (NIST)

EXHIBIT 2. INTRODUCTION

2.1. SCOPE

Reference:	FCC Parts 2 and 90 (Subpart R)
Title:	Code of Federal Regulations (CFR) Title 47 Telecommunication, Parts 2 & 90
Purpose of Test:	To obtain FCC equipment authorization for radio operating in the frequency bands 764-776 MHz and 794-806MHz.
Test Procedures:	Both conducted and radiated emissions measurements were conducted in accordance with American National Standards Institute ANSI C63.4 - American National Standard for Methods of Measurement of Radio-Noise Emissions from Low-Voltage Electrical and Electronic Equipment in the Range of 9 kHz to 40 GHz.
Environmental Classification:	Commercial, industrial or business

2.2. RELATED SUBMITTAL(S)/GRANT(S)

None.

2.3. NORMATIVE REFERENCES

Publication	Year	Title
FCC CFR Parts 0-19, 80-End	2004	Code of Federal Regulations – Telecommunication
ANSI C63.4	2003	American National Standard for Methods of Measurement of Radio-Noise Emissions from Low-Voltage Electrical and Electronic Equipment in the Range of 9 KHz to 40 GHz
TIA/EIA 603, Edition B	01-Nov-2002	Land Mobile FM or PM Communications Equipment Measurement and Performance Standards

EXHIBIT 3. PERFORMANCE ASSESSMENT

3.1. CLIENT INFORMATION

APPLICANT	
Name:	TX RX Systems, Inc.
Address:	8625 Industrial Parkway Angola, NY 14006 USA
Contact Person:	Mr. Dennis Hohman Phone #: (716) 549-4700 ext 5080 Fax #: (716) 549-4772 Email Address: dhohman@bird-technologies.com

MANUFACTURER	
Name:	TX RX Systems, Inc.
Address:	8625 Industrial Parkway Angola, NY 14006 USA
Contact Person:	Mr. Dennis Hohman Phone #: (716) 549-4700 ext 5080 Fax #: (716) 549-4772 Email Address: dhohman@bird-technologies.com

3.2. EQUIPMENT UNDER TEST (EUT) INFORMATION

The following information (with the exception of the Date of Receipt) has been supplied by the applicant.

Brand Name:	TX RX Systems, Inc.
Product Name:	Signal Booster II
Model Name or Number:	61-83B-50
Type of Equipment:	Non-broadcast Radio Communication Equipment
External Power Supply:	N/A
Primary User functions of EUT:	Signal Booster II is designed to boost the power level of one or more RF signals and retransmit them from a signal distribution system comprised of antennas or radiating coaxial cable.
Transmitting/Receiving Antenna Type:	Non-Integral

3.3. EUT'S TECHNICAL SPECIFICATIONS

TRANSMITTER	
Equipment Type:	Base station (fixed use)
Intended Operating Environment:	Commercial, industrial or business environment
Power Supply Requirement:	100-240 VAC; 50/60 Hz or +24 to +27 VDC
RF Input Power Rating:	- 15 dBm
RF Output Power Rating:	+ 36 dBm (single carrier)
Operating Frequency Range:	Uplink: 764-776 MHz; Downlink: 794-806 MHz
RF Output Impedance:	50 Ohms
Occupied Bandwidth (99%):	EXTENDER (The 99% OBW of the rf output signal is the same as that of the rf input signal from a FCC certified transmitter)
Emission Designation:	<ul style="list-style-type: none"> • F1D • F3E • G3E
Antenna Connector Type:	N Female
Antenna Description:	<ul style="list-style-type: none"> • Outdoor/Top-Roof Antenna: The Antenna Gain Limit is 10 dBd • In-building antenna: radiating coaxial cable or a network ¼ wave whip antenna (gain not exceed 0 dB)

RECEIVER	
Equipment Type:	Base station (fixed use)
Intended Operating Environment:	Commercial, industrial or business environment
Power Supply Requirement:	100-240 VAC; 50/60 Hz or +24 to +27 VDC
RF Input Power Rating:	- 15 dBm
Operating Frequency Range:	Uplink: 764-776 MHz; Downlink: 794-806 MHz

3.4. LIST OF EUT'S PORTS

Port Number	EUT's Port Description	Number of Identical Ports	Connector Type	Cable Type (Shielded/Non-shielded)
1	Downlink IN – Uplink OUT	1	N female	Shielded
2	Uplink IN – Downlink OUT	1	N female	Shielded
3	Backup DC Power	1	2 Term Barrier	Non-shielded
4	Alarm Contacts	1	6 Term Barrier	Non-shielded
5	AC Line Filter	1	--	Non-shielded
6	Accessory AC Outlet	2	AC Duplex Receptacles	Non-shielded

3.5. ANCILLARY EQUIPMENT

None.

3.6. GENERAL TEST SETUP

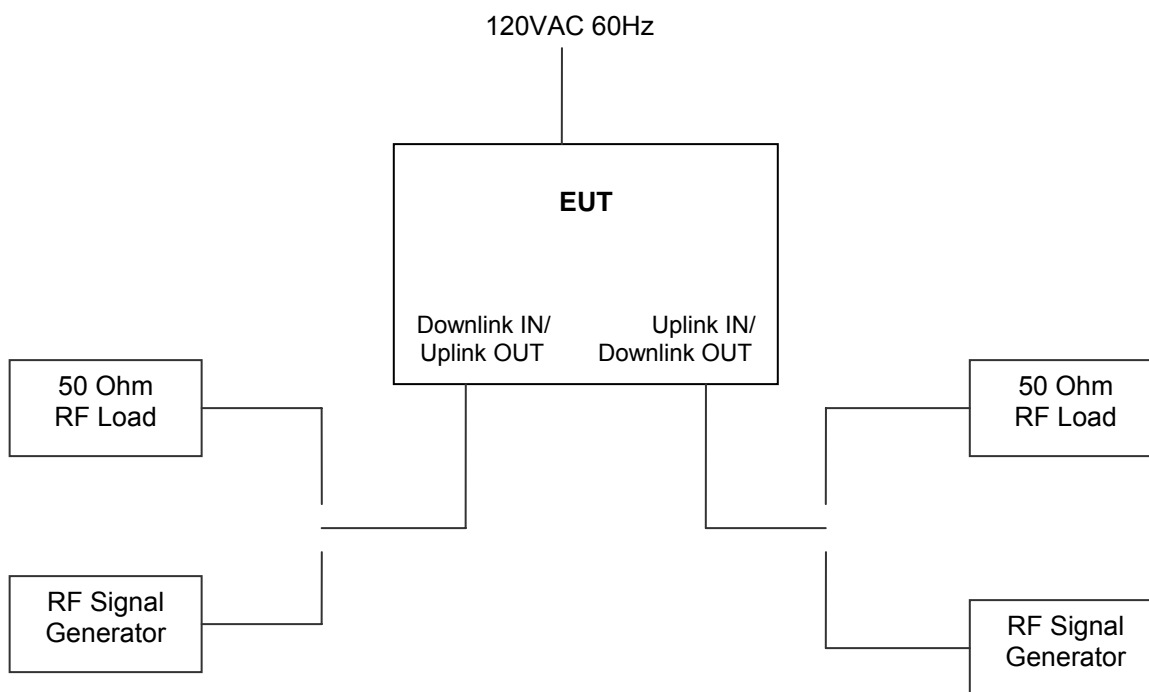

EXHIBIT 4. EUT OPERATING CONDITIONS AND CONFIGURATIONS DURING TESTS

4.1. CLIMATE TEST CONDITIONS

The climate conditions of the test environment are as follows:

Temperature:	21°C
Humidity:	51%
Pressure:	102 kPa
Power input source:	100-240 VAC; 50/60 Hz or +24 to +27 VDC

4.2. OPERATIONAL TEST CONDITIONS & ARRANGEMENT FOR TEST SIGNALS

Operating Modes:	The transmitter was operated in a continuous transmission mode with the carrier modulated as specified in the Test Data.
Special Test Software:	N/A
Special Hardware Used:	N/A
Transmitter Test Antenna:	The EUT is tested with the transmitter antenna port terminated to a 50 Ohms RF Load.

Transmitter Test Signals	
Frequency Band(s):	Uplink: 764-776 MHz; Downlink: 794-806 MHz
Frequency(ies) Tested: (Near lowest, near middle and near highest frequencies in the frequency range of operation.)	764, 770 and 776 MHz 794, 800 and 806 MHz
RF Power Output (measured maximum output power):	36.31 dBm
Normal Test Modulation:	Unmodulated, G3E, F1D & F3E
Modulating signal source:	External

EXHIBIT 5. SUMMARY OF TEST RESULTS

5.1. LOCATION OF TESTS

All of the measurements described in this report were performed at Ultratech Group of Labs located in the city of Oakville, Province of Ontario, Canada.

- AC Power Line Conducted Emissions were performed in UltraTech's shielded room, 24'(L) by 16'(W) by 8'(H).
- Radiated Emissions were performed at the Ultratech's 3 Meter Open Field Test Site (OFTS) situated in the Town of Oakville, province of Ontario.

The above sites have been calibrated in accordance with ANSI C63.4, and found to be in compliance with the requirements of Sec. 2.948 of the FCC Rules. The descriptions and site measurement data of the Oakville Open Field Test Site has been filed with FCC office (FCC File No.: 31040/SIT 1300B3) and Industry Canada office (Industry Canada File No.: IC2049). Last Date of Site Calibration: January 10, 2005.

5.2. APPLICABILITY & SUMMARY OF EMC EMISSION TEST RESULTS

FCC Section(s)	Test Requirements	Applicability (Yes/No)
90.541 & 2.1046	RF Power Output & Intermodulation	Yes
1.1307, 1.1310 & 2.1091	RF Exposure Limit	Yes
90.539 & 2.1055	Frequency Stability	⁽¹⁾ Not applicable for amplifier
2.1047(a)	Audio Frequency Response	⁽²⁾ Not applicable for amplifier
2.1047(b)	Modulation Limiting	⁽²⁾ Not applicable for amplifier
2.1049	Occupied Bandwidth	Yes
90.543(c), 2.1051 & 2.1057	Emission Limitation - Spurious Emissions at Antenna Terminal	Yes
90.543(c), 2.1053 & 2.1057	Emission Limitation - Field Strength of Spurious Emissions	Yes

Signal Booster II, Model No.: 61-83B-50, by **TX RX Systems, Inc.** has also been tested and found to comply with **FCC Part 15, Subpart B - Radio Receivers and Class A Digital Devices**. The engineering test report has been documented and it is available upon request.

Notes:

- (1) Test is not applicable, the EUT is not designed to generate or translate frequencies, it only amplifies the signal it receives.
- (2) Test is not applicable, the EUT does not contain modulation circuitry.

5.3. MODIFICATIONS INCORPORATED IN THE EUT FOR COMPLIANCE PURPOSES

An assembly (Fig. 1) added to the backup DC power input terminals to reduce the conducted emissions.

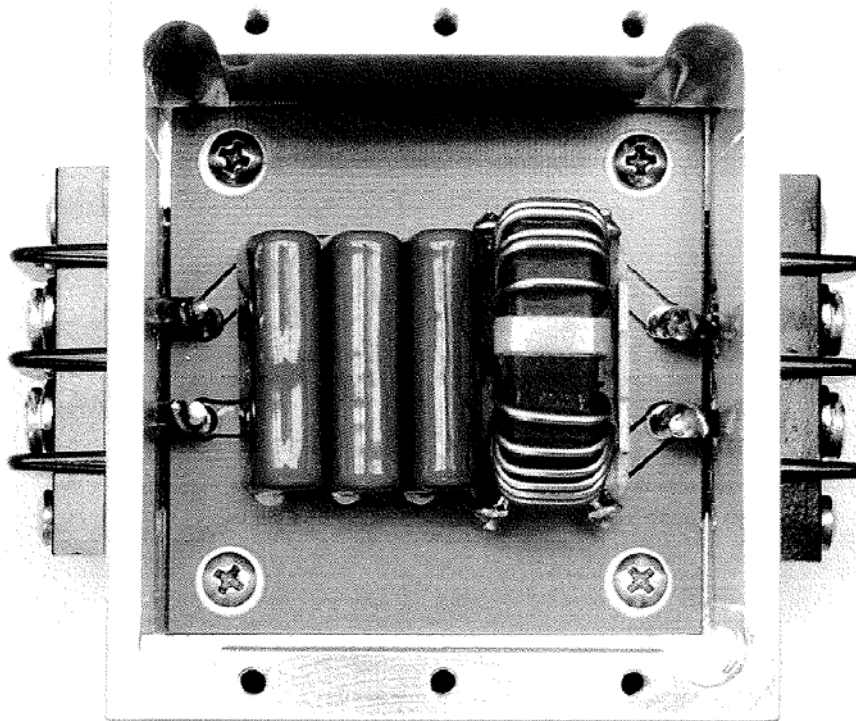

Fig.1

This assembly consists of three capacitors and one inductor. The capacitors are Panasonic part number ECQ-E2225KIB, which are 2.2 μ fd, 250V, metallized polypropylene film, non-polarized. TX RX System has assigned part number 8-20967. The inductor is a JW Miller part number 8108, which is 1MH, 10A inductor. TX RX has assigned part number 8-21128.

EXHIBIT 6. MEASUREMENTS, EXAMINATIONS & TEST DATA FOR EMC EMISSIONS

6.1. TEST PROCEDURES

This section contains test results only. Details of test methods and procedures can be found in Ultratech Test Procedures, File # ULTR P001-2004 and ANSI C63.4.

6.2. MEASUREMENT UNCERTAINTIES

The measurement uncertainties stated were calculated in accordance with requirements of UKAS Document NIS 81 with a confidence level of 95%. Please refer to Exhibit 7 for Measurement Uncertainties.

6.3. MEASUREMENT EQUIPMENT USED

The measurement equipment used complied with the requirements of the Standards referenced in the Methods & Procedures ANSI C63.4 and CISPR 16-1.

6.4. ESSENTIAL/PRIMARY FUNCTIONS AS DECLARED BY THE MANUFACTURER

Signal Booster II is a broadband, bi-directional amplifier capable of up to 80 dB of RF gain and a maximum power output of +36 dBm. It is an on-frequency repeater that can also be referred to as a zone enhancer. The unit is designed for a nominal frequency separation of 30 the uplink and down link branches. The two branches are coupled to the RF input/output ports via a multi-section filter duplexer providing enough isolation to prevent regenerative feedback. Each branch incorporates an Output Leveling Control circuit that reduces device gain by up to 60 dB to maintain full but linear output power output with varying input signal levels and multiple carriers.

6.5. RF POWER OUTPUT & INTERMODULATION [§§ 2.1046 & 90.541]

6.5.1. Limits

§ 90.541 Transmitting power limits: The transmitting power of base, mobile, portable and control stations operating in the 764-776 MHz and 794-806 MHz frequency band must not exceed the maximum limits in this section, and must also comply with any applicable effective radiated power limits in § 90.545.

- (a) The transmitting power of base transmitters must not exceed the limits given in paragraphs (a), (b) and (c) of § 90.635.
- (b) The transmitter output power of mobile and control transmitters must not exceed 30 Watts.
- (c) The transmitter output power of portable (hand-held) transmitters must not exceed 3 Watts.
- (d) Transmitters operating on the narrowband low power channels listed in §§ 90.531(b)(3), 90.531(b)(4), must not exceed 2 watts (ERP).

6.5.2. Method of Measurements

Refer to ULTRATECH Test Procedures, File # ULTR P001-2004 and ANSI C63.4

6.5.3. Test Equipment List

Test Instruments	Manufacturer	Model No.	Serial No.	Frequency Range
Signal Generator	Gigatronics	6061A	5130586	10 kHz - 1050 MHz
Signal Generator	Fluke	6061A	4770301	10 kHz - 1050 MHz
Signal Generator	Gigatronics	6061A	5130408	10 kHz - 1050 MHz
Combiner	Mini-Circuit	15542	0105	1 MHz - 1 GHz
Spectrum Analyzer	Advantest	R3271	15050203	100Hz - 26.5GHz

6.5.4. Test Arrangement

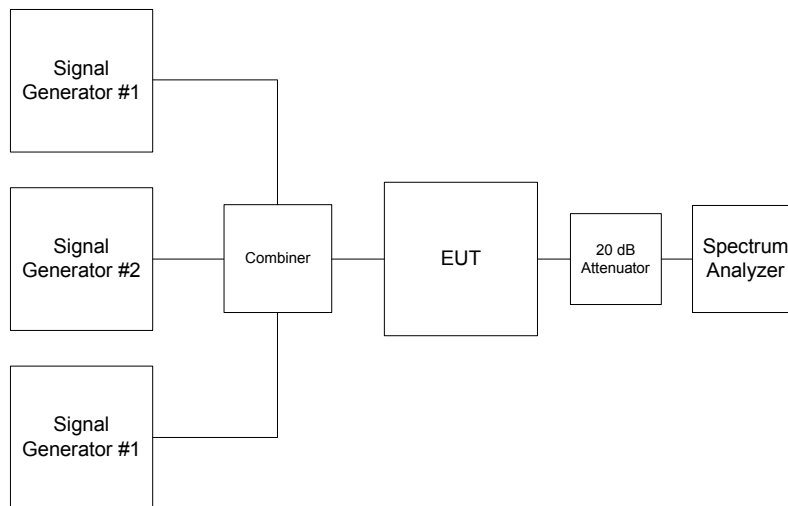

6.5.5. Test Data

6.5.5.1. RF POWER OUTPUT with MODULATION, SINGLE CHANNEL, MAXIMUM RF IN = - 15 dBm

6.5.5.1.1. 120 VAC 60 Hz input

Test Frequency (MHz)	Modulation	Total RF Output Power at Antenna Port (dBm)	Maximum Antenna Gain allowed (dB)	Maximum ERP (dBm)	RF Output Power Ratings at Antenna Port (dBm)
764-776 MHz Band (Uplink)					
764	F1D/F3E/G3E	35.38	10	45.38	36
770	F1D/F3E/G3E	36.11	10	46.11	36
776	F1D/F3E/G3E	35.31	10	45.31	36
794-806 MHz Band (Downlink)					
794	F1D/F3E/G3E	36.15	10	46.15	36
800	F1D/F3E/G3E	36.12	10	46.12	36
806	F1D/F3E/G3E	36.24	10	46.24	36

6.5.5.1.2. +27 VDC input

Test Frequency (MHz)	Modulation	Total RF Output Power at Antenna Port (dBm)	Maximum Antenna Gain allowed (dB)	Maximum ERP (dBm)	RF Output Power Ratings at Antenna Port (dBm)
764-776 MHz Band (Uplink)					
764	F1D/F3E/G3E	35.47	10	45.47	36
770	F1D/F3E/G3E	36.21	10	46.21	36
776	F1D/F3E/G3E	35.41	10	45.41	36
794-806 MHz Band (Downlink)					
794	F1D/F3E/G3E	36.21	10	46.21	36
800	F1D/F3E/G3E	36.19	10	46.19	36
806	F1D/F3E/G3E	36.31	10	46.31	36

6.5.5.2. INTERMODULATION & PEAK POWERS – NO MODULATION

Frequency (MHz)	Number of In/Out Channels	Modulation	Maximum RF Input (conducted) (dBm)	Maximum RF Output (conducted) (dBm)	Maximum Antenna Gain allowed (dB)	Maximum ERP Measured (dBm)
764-776 MHz Band (Uplink)						
764.000	1	unmodulated	-15	35.75	10	45.75
764.000 764.025	2	unmodulated	-18.91	31.75	10	41.75
764.000 764.025 764.050	3	unmodulated	-20.51	31.00	10	41.00
770-776 MHz Band (Uplink)						
770.000	1	unmodulated	-15	35.31	10	45.31
770.000 770.025	2	unmodulated	-19.91	32.19	10	42.19
770.000 770.025 770.050	3	unmodulated	-21.11	31.28	10	41.28
776-776 MHz Band (Uplink)						
776.000	1	unmodulated	-15	34.72	10	44.72
776.000 775.975	2	unmodulated	-20.01	31.75	10	41.75
776.000 775.975 775.950	3	unmodulated	-21.11	30.72	10	40.72
794-806 MHz Band (Downlink)						
794.000	1	unmodulated	-15	35.06	10	45.06
794.000 794.025	2	unmodulated	-19.41	31.72	10	41.72
794.000 794.025 794.050	3	unmodulated	-20.31	30.75	10	40.75
800-806 MHz Band (Downlink)						
800.000	1	unmodulated	-15	35.97	10	45.97
800.000 800.025	2	unmodulated	-20.21	32.06	10	42.06
800.000 800.025 800.050	3	unmodulated	-21.51	30.88	10	40.88
806-806 MHz Band (Downlink)						
806.000	1	unmodulated	-15	35.41	10	45.41
806.000 805.975	2	unmodulated	-20.21	31.25	10	41.25
806.000 805.975 805.950	3	unmodulated	-21.31	30.31	10	40.31

See the following plots for details.

Plot 6.5.5.2.1
Intermodulation with 1 RF signal input/output in 764-776 MHz band
Fc: 764 MHz
RF Input: -15 dBm

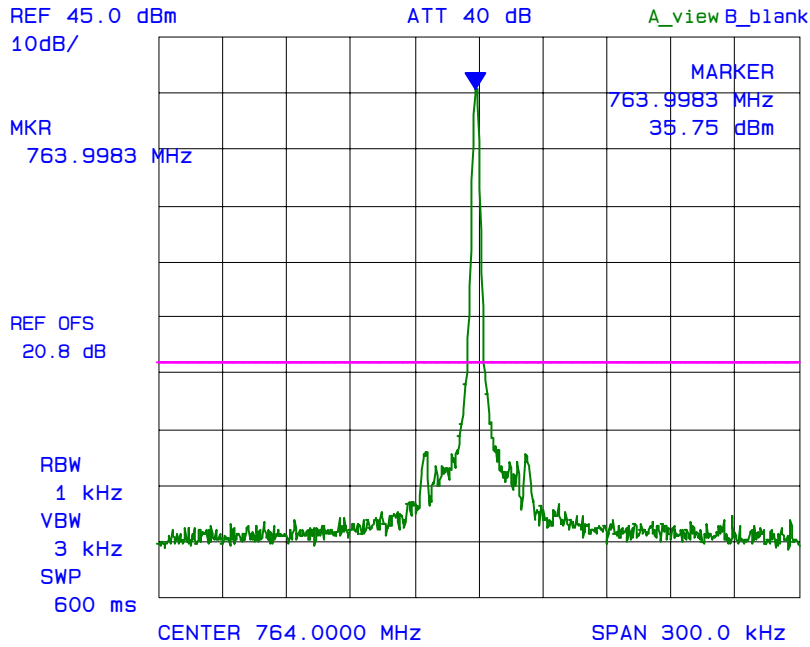

Plot 6.5.5.2.2
Intermodulation with 2 RF signal inputs/outputs in 764-776 MHz band
Fc: 764 MHz & Fc + 25 kHz
RF Input: (2) -19.11 dBm, (3) -18.91 dBm

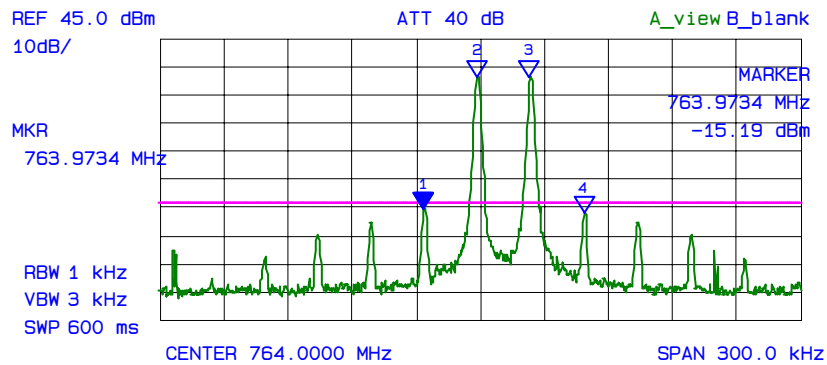

*** Multi Marker List ***

No.	Freq (MHz)	Power (dBm)	Marker
No. 1:	763.9734	-15.19	A
No. 2:	763.9983	31.75	A
No. 3:	764.0231	31.81	A
No. 4:	764.0484	-16.94	A
No. 5:			
No. 6:			
No. 7:			
No. 8:			
:			

Plot 6.5.5.2.3
 Intermodulation with 3 RF signal inputs/outputs in 764-776 MHz band
 Fc: 764 MHz, Fc + 25 kHz & Fc + 50 kHz,
 RF Input: (2) -20.91dBm, (3) -20.71dBm, (4) -20.51dBm

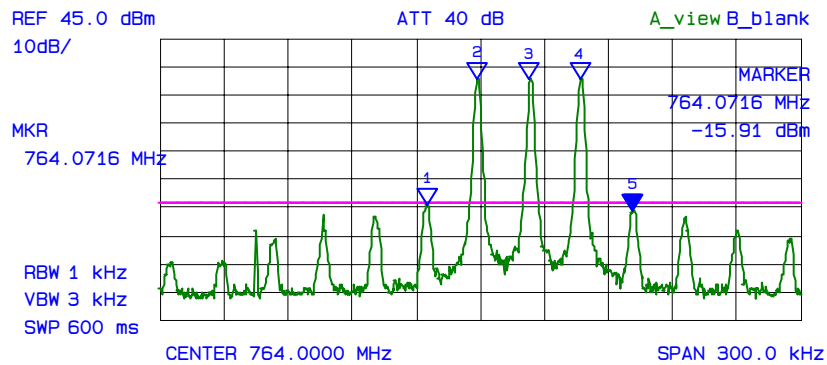

*** Multi Marker List ***

No.	Frequency (MHz)	Power (dBm)	Band
No. 1:	763.9751	-13.63	A
No. 2:	763.9983	31.00	A
No. 3:	764.0231	30.97	A
No. 4:	764.0467	30.97	A
No. 5:	764.0716	-15.91	A
No. 6:			
No. 7:			
No. 8:			

Plot 6.5.5.2.4
Intermodulation with 1 RF signal input/output in 764-776 MHz band
Fc: 770 MHz
RF Input: -15dBm

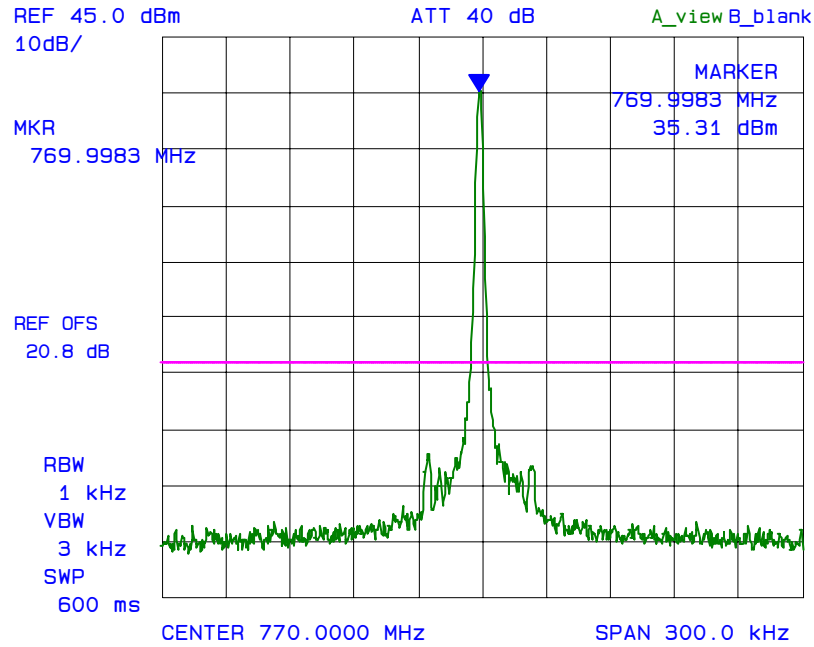

ULTRATECH GROUP OF LABS

3000 Bristol Circle, Oakville, Ontario, Canada L6H 6G4
Tel. #: 905-829-1570, Fax. #: 905-829-8050, Email: vic@ultratech-labs.com, Website: <http://www.ultratech-labs.com>

File #: TXRX-013F90R

October 5, 2005

All test results contained in this engineering test report are traceable to National Institute of Standards and Technology (NIST)

Plot 6.5.5.2.5
Intermodulation with 2 RF signal inputs/outputs in 764-776 MHz band
Fc: 770 MHz & Fc + 25 kHz
RF Input: (2) -20.21 dBm, (3) -19.91 dBm

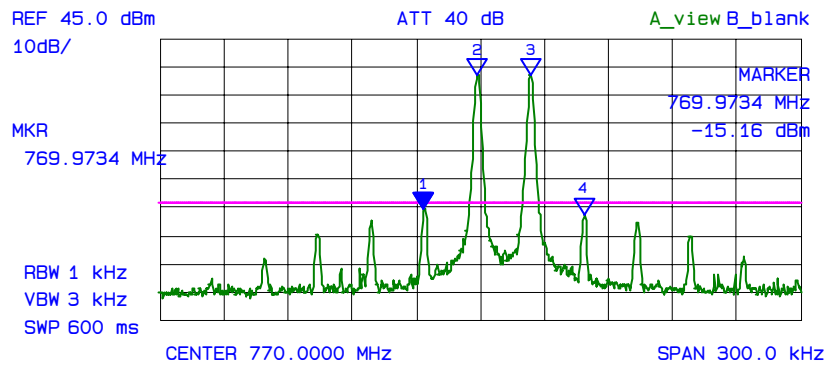

*** Multi Marker List ***

No.	Freq (MHz)	Power (dBm)	Marker
No. 1:	769.9734	-15.16	A
No. 2:	769.9987	32.13	A
No. 3:	770.0236	32.19	A
No. 4:	770.0484	-17.47	A
No. 5:			
No. 6:			
No. 7:			
No. 8:			
:			

Plot 6.5.5.2.6
Intermodulation with 3 RF signal inputs/outputs in 764-776 MHz band
Fc: 770 MHz, Fc + 25 kHz & Fc + 50 kHz
RF Input: (2) -21.51dBm, (3) -21.11dBm, (4) -21.21dBm

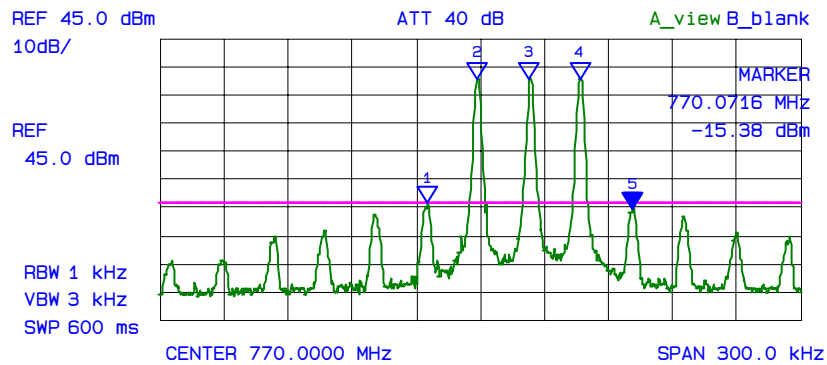

*** Multi Marker List ***

No.	Frequency (MHz)	Power (dBm)	Marker
No. 1:	769.9751	-13.25	A
No. 2:	769.9983	31.28	A
No. 3:	770.0231	31.25	A
No. 4:	770.0467	31.19	A
No. 5:	770.0716	-15.38	A
No. 6:			
No. 7:			
No. 8:			
:			

Plot 6.5.5.2.7
Intermodulation with 1 RF signal input/output in 764-776 MHz band
Fc: 776 MHz
RF Input: -15 dBm

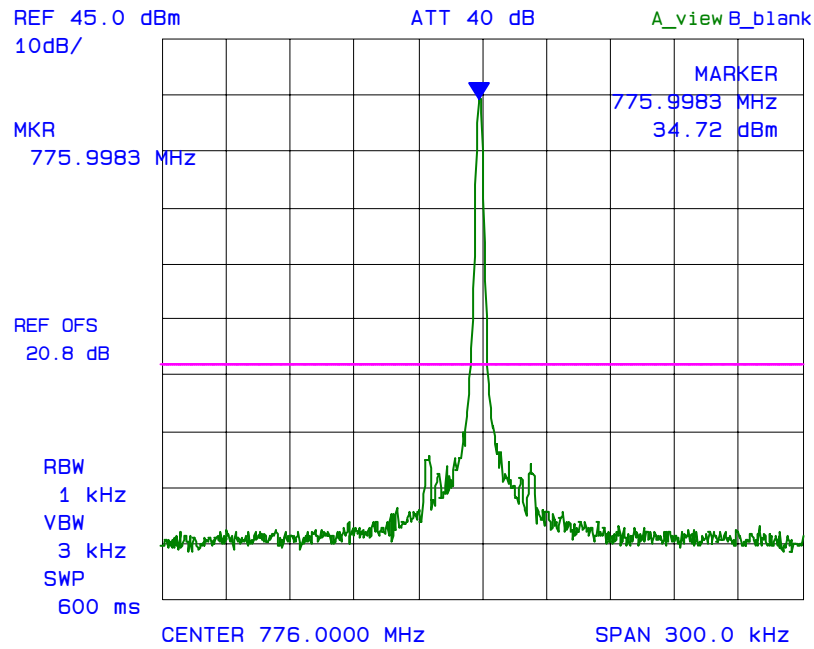

ULTRATECH GROUP OF LABS

3000 Bristol Circle, Oakville, Ontario, Canada L6H 6G4
Tel. #: 905-829-1570, Fax. #: 905-829-8050, Email: vic@ultratech-labs.com, Website: <http://www.ultratech-labs.com>

File #: TXRX-013F90R

October 5, 2005

All test results contained in this engineering test report are traceable to National Institute of Standards and Technology (NIST)

Plot 6.5.5.2.8
Intermodulation with 2 RF signal inputs/outputs in 764-776 MHz band
Fc: 776 MHz & Fc - 25 kHz
RF Input: (2) -20.31 dBm, (3) -20.01 dBm

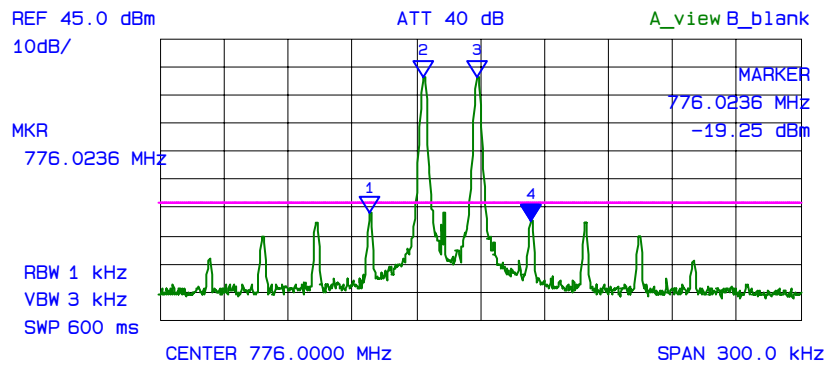

*** Multi Marker List ***

No.	Freq (MHz)	Power (dBm)	Att (dB)
No. 1:	775.9481	-16.53	A
No. 2:	775.9734	31.72	A
No. 3:	775.9983	31.75	A
No. 4:	776.0236	-19.25	A
No. 5:			
No. 6:			
No. 7:			
No. 8:			
:			

Plot 6.5.5.2.9
Intermodulation with 3 RF signal inputs/outputs in 764-776 MHz band
Fc: 776 MHz, Fc - 25 kHz & Fc - 50 kHz
RF Input: (2) -21.51 dBm, (3) -21.11 dBm, (4) -21.21 dBm

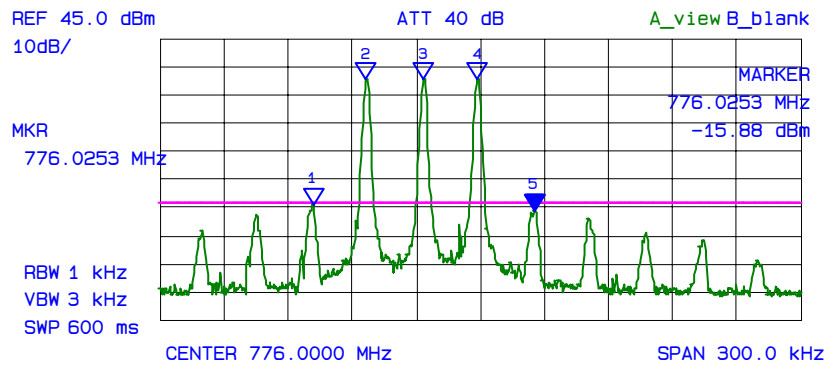

*** Multi Marker List ***

No.	Freq (MHz)	Power (dBm)	Marker
No. 1:	775.9216	-13.97	A
No. 2:	775.9464	30.72	A
No. 3:	775.9734	30.69	A
No. 4:	775.9983	30.66	A
No. 5:	776.0253	-15.88	A
No. 6:			
No. 7:			
No. 8:			
:			

Plot 6.5.5.2.10
Intermodulation with 1 RF signal input/output in 794-806 MHz band
Fc: 794 MHz
RF Input: -15 dBm

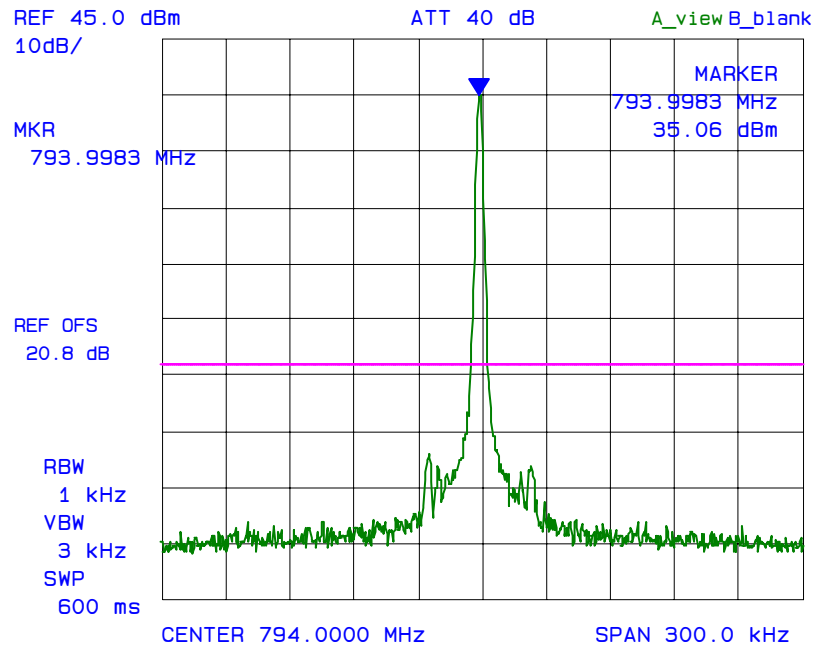

ULTRATECH GROUP OF LABS

3000 Bristol Circle, Oakville, Ontario, Canada L6H 6G4
Tel. #: 905-829-1570, Fax. #: 905-829-8050, Email: vic@ultratech-labs.com, Website: <http://www.ultratech-labs.com>

File #: TXRX-013F90R

October 5, 2005

All test results contained in this engineering test report are traceable to National Institute of Standards and Technology (NIST)

Plot 6.5.5.2.11
 Intermodulation with 2 RF signal inputs/outputs in 794-806 MHz band
 Fc: 794 MHz & Fc + 25 kHz
 RF Input: (2) -19.61 dBm, (3) -19.41 dBm

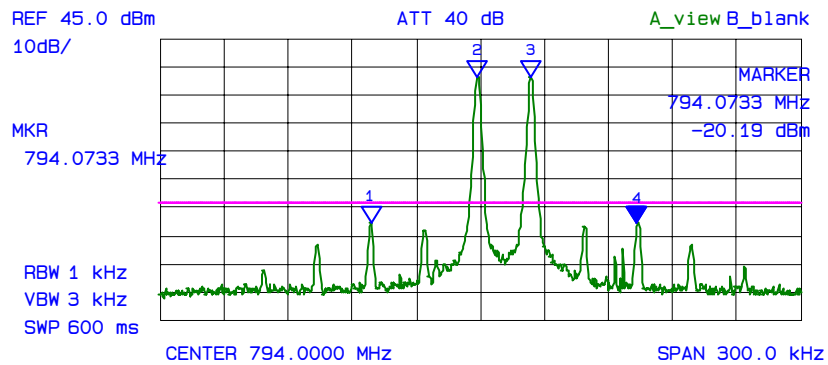

*** Multi Marker List ***

No.	Freq (MHz)	Power (dBm)	Label
No. 1:	793.9486	-19.81	A
No. 2:	793.9987	31.59	A
No. 3:	794.0236	31.72	A
No. 4:	794.0733	-20.19	A
No. 5:			
No. 6:			
No. 7:			
No. 8:			
:			

Plot 6.5.5.2.12
Intermodulation with 3 RF signal inputs/outputs in 794-806 MHz band
Fc: 794 MHz, Fc + 25 kHz & Fc + 50 kHz,
RF Input: (2) -20.51dBm, (3) -20.31dBm, (4) -20.81dBm

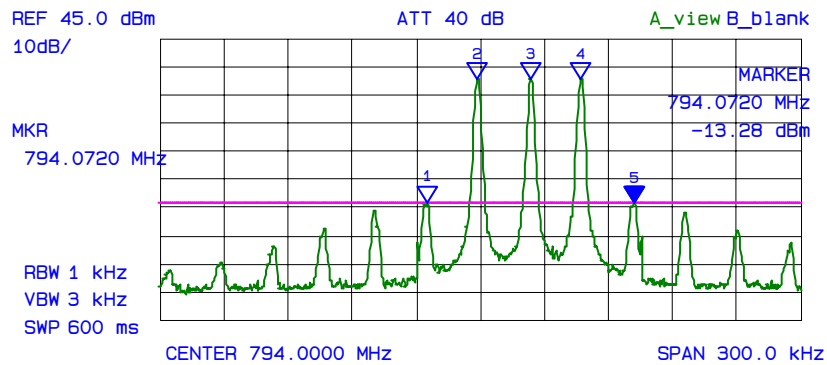

*** Multi Marker List ***

No.	Frequency (MHz)	Power (dBm)	Label
No. 1:	793.9751	-13.00	A
No. 2:	793.9983	30.75	A
No. 3:	794.0236	30.69	A
No. 4:	794.0471	30.69	A
No. 5:	794.0720	-13.28	A
No. 6:			
No. 7:			
No. 8:			
:			

Plot 6.5.5.2.13
Intermodulation with 1 RF signal input/output in 794-806 MHz band
Fc: 800 MHz
RF Input: -15 dBm

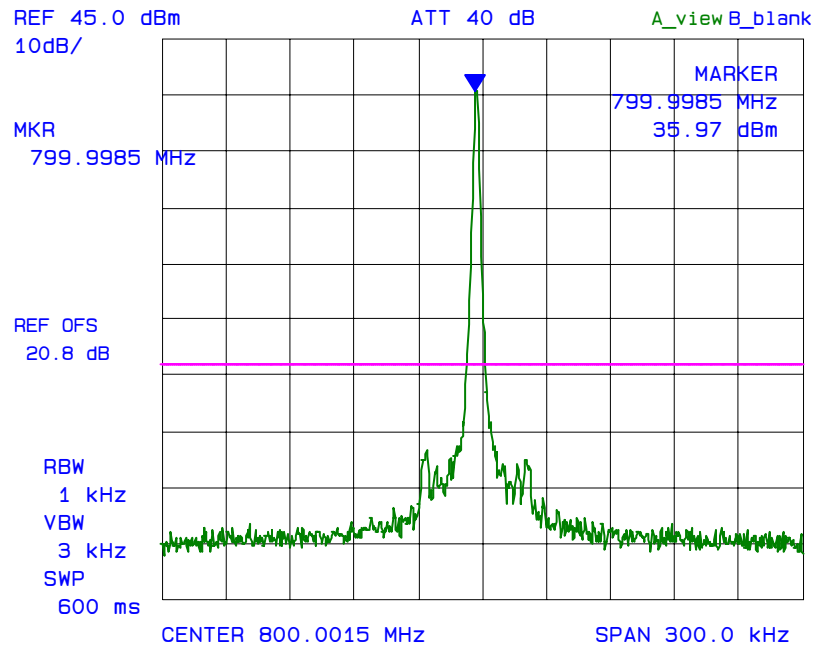

ULTRATECH GROUP OF LABS

3000 Bristol Circle, Oakville, Ontario, Canada L6H 6G4
Tel. #: 905-829-1570, Fax. #: 905-829-8050, Email: vic@ultratech-labs.com, Website: <http://www.ultratech-labs.com>

File #: TXRX-013F90R

October 5, 2005

All test results contained in this engineering test report are traceable to National Institute of Standards and Technology (NIST)

Plot 6.5.5.2.14
Intermodulation with 2 RF signal inputs/outputs in 794-806 MHz band
Fc: 800 MHz & Fc + 25 kHz
RF Input: (2) -20.21dBm, (3) -20.31dBm

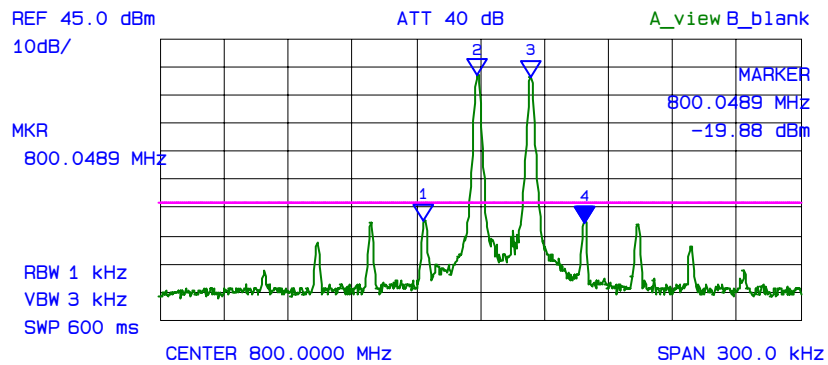

*** Multi Marker List ***

No.	Freq (MHz)	Power (dBm)	Label
No. 1:	799.9734	-19.25	A
No. 2:	799.9983	32.06	A
No. 3:	800.0236	31.97	A
No. 4:	800.0489	-19.88	A
No. 5:			
No. 6:			
No. 7:			
No. 8:			
:			

Plot 6.5.5.2.15
Intermodulation with 3 RF signal inputs/outputs in 794-806 MHz band
Fc: 800 MHz, Fc + 25 kHz & Fc + 50 kHz
RF Input: (2) -21.51dBm, (3) -21.51dBm, (4) -21.81dBm

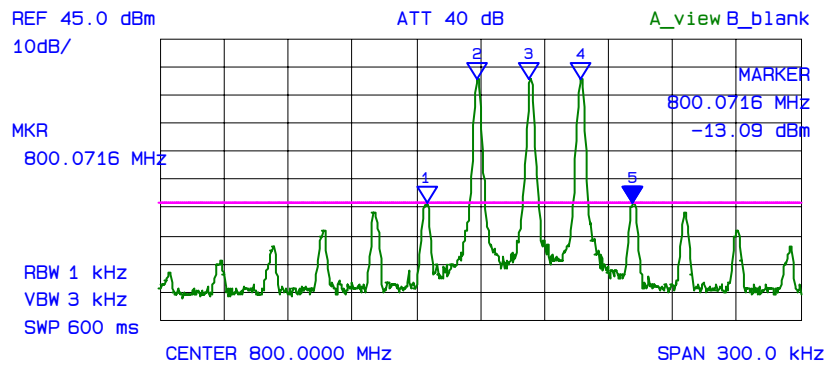

*** Multi Marker List ***

No.	Freq (MHz)	Power (dBm)	Label
No. 1:	799.9747	-13.06	A
No. 2:	799.9983	30.88	A
No. 3:	800.0231	30.72	A
No. 4:	800.0471	30.88	A
No. 5:	800.0716	-13.09	A
No. 6:			
No. 7:			
No. 8:			
:			

Plot 6.5.5.2.16
Intermodulation with 1 RF signal input/output in 794-806 MHz band
Fc: 806 MHz
RF Input: -15 dBm

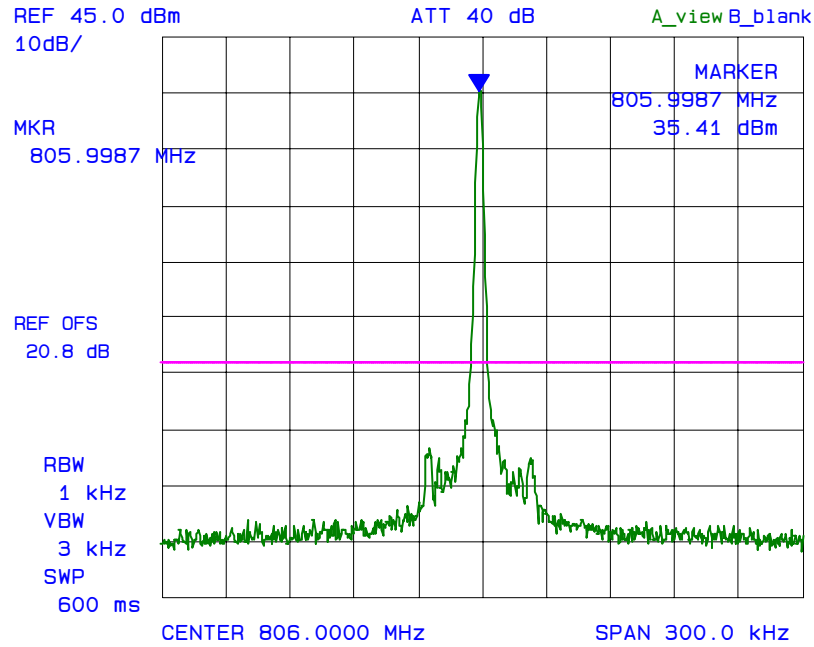

ULTRATECH GROUP OF LABS

3000 Bristol Circle, Oakville, Ontario, Canada L6H 6G4
Tel. #: 905-829-1570, Fax. #: 905-829-8050, Email: vic@ultratech-labs.com, Website: <http://www.ultratech-labs.com>

File #: TXRX-013F90R

October 5, 2005

All test results contained in this engineering test report are traceable to National Institute of Standards and Technology (NIST)

Plot 6.5.5.2.17
 Intermodulation with 2 RF signal inputs/outputs in 794-806 MHz band
 Fc: 806 MHz & Fc - 25 kHz
 RF Input: (2) -20.41dBm, (3) -20.21dBm

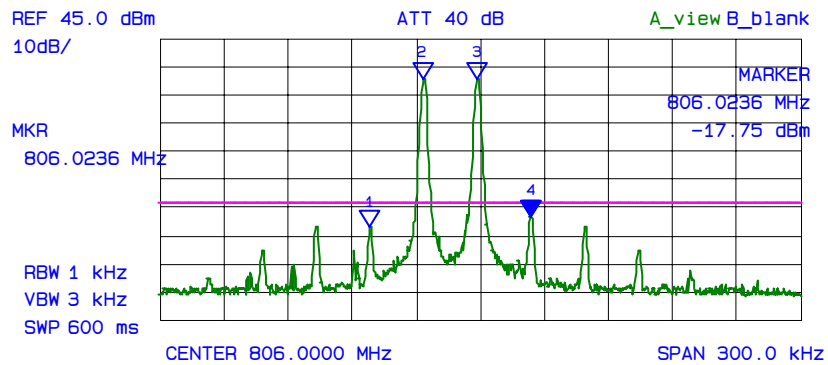

*** Multi Marker List ***

No.	Freq (MHz)	Power (dBm)	Label
No. 1:	805.9481	-21.59	A
No. 2:	805.9730	31.25	A
No. 3:	805.9983	31.22	A
No. 4:	806.0236	-17.75	A
No. 5:			
No. 6:			
No. 7:			
No. 8:			

Plot 6.5.5.2.18
 Intermodulation with 3 RF signal inputs/outputs in 794-806 MHz band
 Fc: 806 MHz, Fc - 25 kHz & Fc - 50 kHz
 RF Input: (2) -21.51dBm, (3) -21.31dBm, (4) -21.71dBm

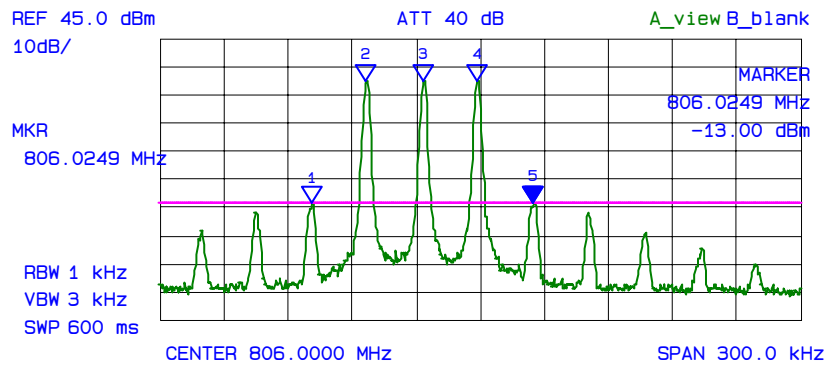

*** Multi Marker List ***

No.	Freq (MHz)	Power (dBm)	Label
No. 1:	805.9211	-13.13	A
No. 2:	805.9464	30.28	A
No. 3:	805.9734	30.31	A
No. 4:	805.9983	30.28	A
No. 5:	806.0249	-13.00	A
No. 6:			
No. 7:			
No. 8:			
:			

6.6. RF EXPOSURE REQUIREMENTS [§§ 1.1310 & 2.1091]

6.6.1. Limits

FCC 1.1310:- The criteria listed in the following table shall be used to evaluate the environmental impact of human exposure to radio-frequency (RF) radiation as specified in 1.1307(b).

TABLE 1—LIMITS FOR MAXIMUM PERMISSIBLE EXPOSURE (MPE)

Frequency range (MHz)	Electric field strength (V/m)	Magnetic field strength (A/m)	Power density (mW/cm ²)	Averaging time (minutes)
(A) Limits for Occupational/Controlled Exposures				
0.3–3.0	614	1.63	*(100)	6
3.0–30	1842/f	4.89/f	*(900/f ²)	6
30–300	61.4	0.163	1.0	6
300–1500	f/300	6
1500–100,000	5	6
(B) Limits for General Population/Uncontrolled Exposure				
0.3–1.34	614	1.63	*(100)	30
1.34–30	824/f	2.19/f	*(180/f ²)	30
30–300	27.5	0.073	0.2	30
300–1500	f/1500	30
1500–100,000	1.0	30

f = frequency in MHz

* = Plane-wave equivalent power density

NOTE 1 TO TABLE 1: Occupational/controlled limits apply in situations in which persons are exposed as a consequence of their employment provided those persons are fully aware of the potential for exposure and can exercise control over their exposure. Limits for occupational/controlled exposure also apply in situations when an individual is transient through a location where occupational/controlled limits apply provided he or she is made aware of the potential for exposure.

NOTE 2 TO TABLE 1: General population/uncontrolled exposures apply in situations in which the general public may be exposed, or in which persons that are exposed as a consequence of their employment may not be fully aware of the potential for exposure or can not exercise control over their exposure.

6.6.2. Method of Measurements

Refer to FCC @ 1.1310 and 2.1091

- In order to demonstrate compliance with MPE requirements (see Section 2.1091), the following information is typically needed:
 - (1) Calculation that estimates the minimum separation distance (20 cm or more) between an antenna and persons required to satisfy power density limits defined for free space.
 - (2) Antenna installation and device operating instructions for installers (professional/unskilled users), and the parties responsible for ensuring compliance with the RF exposure requirement.
 - (3) Any caution statements and/or warning labels that are necessary in order to comply with the exposure limits.
 - (4) Any other RF exposure related issues that may affect MPE compliance.

Calculation Method of RF Safety Distance:

$$S = PG/4\pi r^2 = EIRP/4\pi r^2$$

Where: P: power input to the antenna in mW
EIRP: Equivalent (effective) isotropic radiated power.
S: power density mW/cm²
G: numeric gain of antenna relative to isotropic radiator
r: distance to centre of radiation in cm

$$r = \sqrt{PG/4\pi S}$$

- For portable transmitters (see Section 2.1093), or devices designed to operate next to a person's body, compliance is determined with respect to the SAR limit (define in the body tissues) for near-field exposure conditions. If the maximum average output power, operating condition configurations and exposure conditions are comparable to those of existing cellular and PCS phones, SAR evaluation may be required in order to determine if such a device complies with SAR limit. When SAR evaluation data is not available, and the additional supporting information cannot assure compliance, the Commission may request that an SAR evaluation be performed, as provided for in Section 1.1307(d).

6.6.3. Test Data

Antenna Gain Limit specified by Manufacturer: 0 dB (In-building Antenna)

(1) Lowest Frequency (MHz)	Measured RF Conducted Power (dBm)	Calculated EIRP (dBm)	(2) Calculated Minimum RF Safety Distance r (cm)*	Manufacturer' Specified Separation Distance (cm)
794	36.31	38.46	33	33

- (1) The calculation is based on the lowest frequency (794 MHz) in the downlink frequency band and the highest conducted power (36.31dBm) for the worst case.
- (2) The minimum separation distance between the antenna and bodies of users are calculated using the following formula:

$$\text{RF EXPOSURE DISTANCE LIMITS: } r = (PG/4\pi S)^{1/2} = (\text{EIRP}/4\pi S)^{1/2}$$

$$S = 794/1500 \text{ mW/cm}^2 \text{ (for General Population/ Uncontrolled Exposure)}$$

$$\text{EIRP} = 38.46 \text{ dBm} = 10^{(38.46/10)} \text{ mW}$$

$$r = (\text{EIRP}/4\pi S)^{1/2} = (10^{(38.46/10)} / 4\pi(794/1500))^{1/2} = 33 \text{ cm}$$

Antenna Gain Limit specified by Manufacturer: 10 dB (Roof Top Antenna)

(1) Lowest Frequency (MHz)	Measured RF Conducted Power (dBm)	Calculated EIRP (dBm)	Calculated Minimum RF Safety Distance r (cm)*	Manufacturer' Specified Separation Distance (cm)
764	36.21	48.36	104	104

- (1) The calculation is based on the lowest frequency (764 MHz) in the uplink frequency band and the highest conducted power (36.21dBm) for the worst case.
- (2) The minimum separation distance between the antenna and bodies of users are calculated using the following formula:

$$\text{RF EXPOSURE DISTANCE LIMITS: } r = (PG/4\pi S)^{1/2} = (\text{EIRP}/4\pi S)^{1/2}$$

$$S = 764/1500 \text{ mW/cm}^2 \text{ (for General Population/ Uncontrolled Exposure)}$$

$$\text{EIRP} = 48.36 \text{ dBm} = 10^{(48.36/10)} \text{ mW}$$

$$r = (\text{EIRP}/4\pi S)^{1/2} = (10^{(48.36/10)} / 4\pi(764/1500))^{1/2} = 104 \text{ cm}$$

Evaluation of RF Exposure Compliance Requirements	
RF Exposure Requirements	Compliance with FCC Rules
Minimum calculated separation distance between antenna and persons required: *Indoor Antenna: 33 cm *Outdoor Antenna: 104 cm	Manufacturer' instruction for separation distance between antenna and persons required: Indoor Antenna: 33 cm Outdoor Antenna: 104 cm
Antenna installation and device operating instructions for installers (professional/unskilled users), and the parties responsible for ensuring compliance with the RF exposure requirement	See user's manual for details.
Caution statements and/or warning labels that are necessary in order to comply with the exposure limits	See user's manual for RF exposure information.
Any other RF exposure related issues that may affect MPE compliance	None.

6.7. OCCUPIED BANDWIDTH [§ 2.1049]

6.7.1. Limits

The spectral shape of the output should look similar to input for all modulations.

6.7.2. Method of Measurements

Refer to ULTRATECH Test Procedures, File # ULTR P001-2004 and ANSI C63.4.

6.7.3. Test Equipment List

Test Instruments	Manufacturer	Model No.	Serial No.	Frequency Range
Spectrum Analyzer	Advantest	R3271	15050203	100Hz-26.5GHz
Function Generator	Stanford Research Systems	DS345	34591	1Hz -30.2 MHz
Voice Guard Digital Speech Encryption	General Electric	9600-SW	9614517	--
Attenuator	Weinschel Corp	48-30-34	BM5354	DC - 18 GHz
Signal Generator	Gigatronc	6061A	5130586	10 kHz - 1050 MHz

6.7.4. Test Arrangement

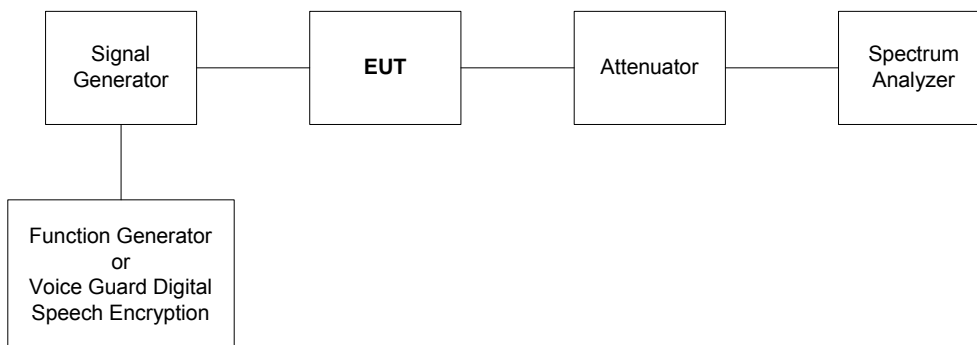

6.7.5. Test Data

6.7.5.1. 20 dB Bandwidth and Gain of the Amplifier

See the following plots for 20 dB passband gains of 764-776 MHz and 794-806 MHz bands.

Plot 6.7.5.1.1
20 dB BW of the 764-776 MHz Passband Gain
RF Input: -15 dBm, Max Gain: 52.28 dB

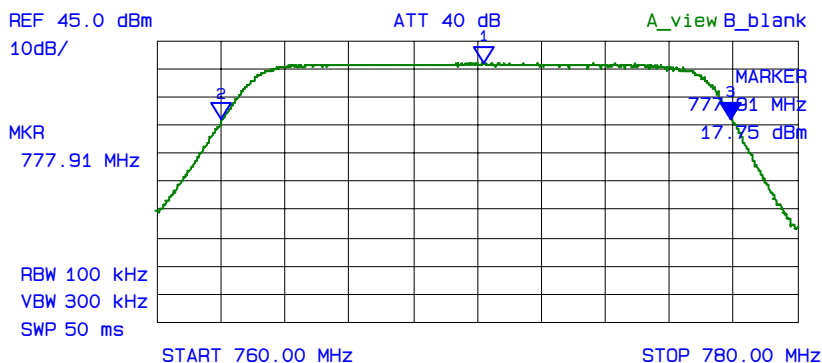

*** Multi Marker List ***

No.	Frequency (MHz)	Gain (dBm)	Label
No. 1:	770.20	37.28	A
No. 2:	762.03	17.00	A
No. 3:	777.91	17.75	A
No. 4:			
No. 5:			
No. 6:			
No. 7:			
No. 8:			
:			

Plot 6.7.5.1.2
20 dB BW of the 794-806 MHz Passband Gain
RF Input: -15 dBm, Max Gain: 52.06 dB

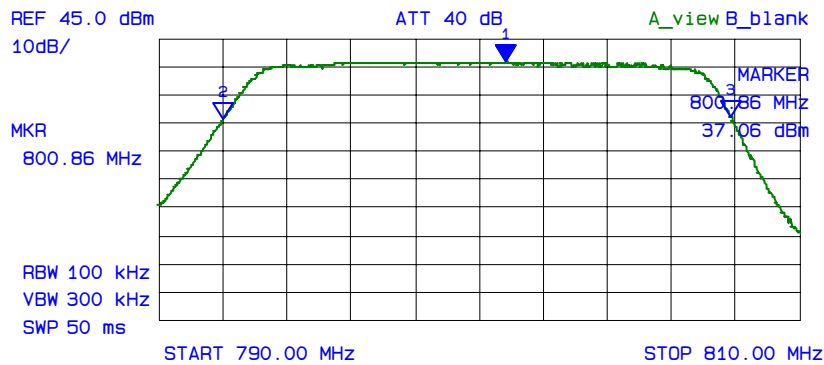

*** Multi Marker List ***

No.	Frequency (MHz)	Gain (dBm)	Label
No. 1:	800.86 MHz	37.06 dBm	A
No. 2:	792.00 MHz	16.91 dBm	A
No. 3:	807.86 MHz	17.53 dBm	A
No. 4:			
No. 5:			
No. 6:			
No. 7:			
No. 8:			
:			

6.7.5.2. 99% Occupied Bandwidth Measurements

Remark: 99% OBW of the RF input and RF output signals were measured for comparison.

Frequency (MHz)	Measured 99% OBW (kHz)	
	RF IN	RF OUT
Channel Spacing: 6.25 kHz, Modulation: FM with 2.5 kHz sine wave signal		
764	5.49	5.46
770	5.46	5.46
776	5.49	5.49
794	5.43	5.43
800	5.43	5.43
806	5.46	5.46
Channel Spacing: 6.25, Modulation: FM with an external 9600 b/s random data source		
764	4.07	4.05
770	4.05	4.07
776	4.05	4.03
794	4.03	4.03
800	4.03	4.05
806	4.03	4.05
Channel Spacing: 12.5 kHz, Modulation: Modulation: FM with 2.5 kHz sine wave signal		
764	10.14	10.14
770	10.00	10.00
776	10.04	10.00
794	10.07	10.07
800	10.11	10.11
806	10.00	10.00
Channel Spacing: 12.5 kHz, Modulation: FM with an external 9600 b/s random data source		
764	10.25	10.18
770	10.29	10.32
776	10.14	10.14
794	10.18	10.21
800	10.54	10.68
806	10.32	10.43

Frequency (MHz)	Measured 99% OBW (kHz)	
	RF IN	RF OUT
Channel Spacing: 25 kHz, Modulation: Modulation: FM with 2.5 kHz sine wave signal		
764	15.30	15.30
770	15.04	15.09
776	15.09	15.09
794	15.09	15.09
800	15.21	15.21
806	15.17	15.17
Channel Spacing: 25 kHz, Modulation: FM with an external 9600 b/s random data source		
764	16.59	16.63
770	16.33	16.63
776	16.54	16.50
794	16.67	16.41
800	16.80	16.50
806	16.67	16.50

See the following plots for 99% occupied bandwidth measurements.

6.7.5.2.1. 6.25 kHz Channel Spacing

Plot 6.7.5.2.1.1: 99% Occupied Bandwidth (Input)
Fc: 764 MHz, Input Level: -15 dBm, Modulation: FM with 2.5 kHz sine wave signal

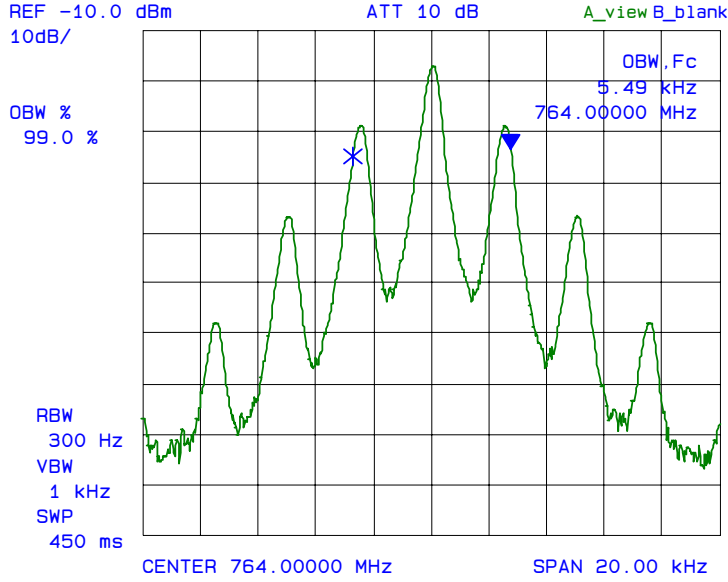

Plot 6.7.5.2.1.2: 99% Occupied Bandwidth (Output)
Fc: 764 MHz, Level: -15 dBm, Modulation: FM with 2.5 kHz sine wave signal

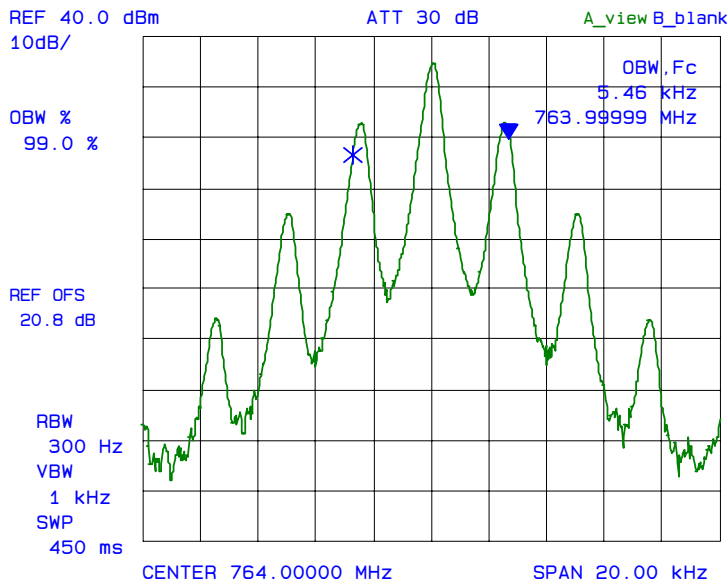

Plot 6.7.5.2.1.3: 99% Occupied Bandwidth (Input)
Fc: 764 MHz, Input Level: -15 dBm, Modulation: FM with an external 9600 bps random data source

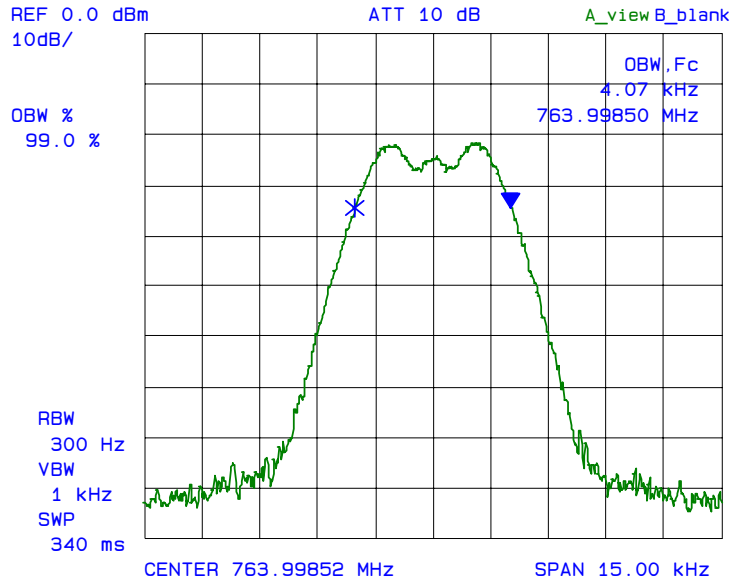

Plot 6.7.5.2.1.4: 99% Occupied Bandwidth (Output)
Fc: 764 MHz, Input Level: -15 dBm, Modulation: FM with an external 9600 bps random data source

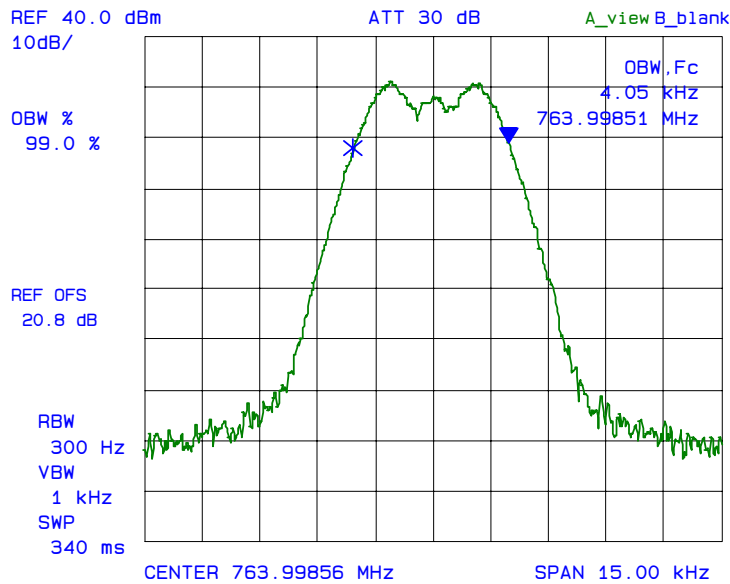

Plot 6.7.5.2.1.5: 99% Occupied Bandwidth (Input)
Fc: 770 MHz, Input Level: -15 dBm, Modulation: FM with 2.5 kHz sine wave signal

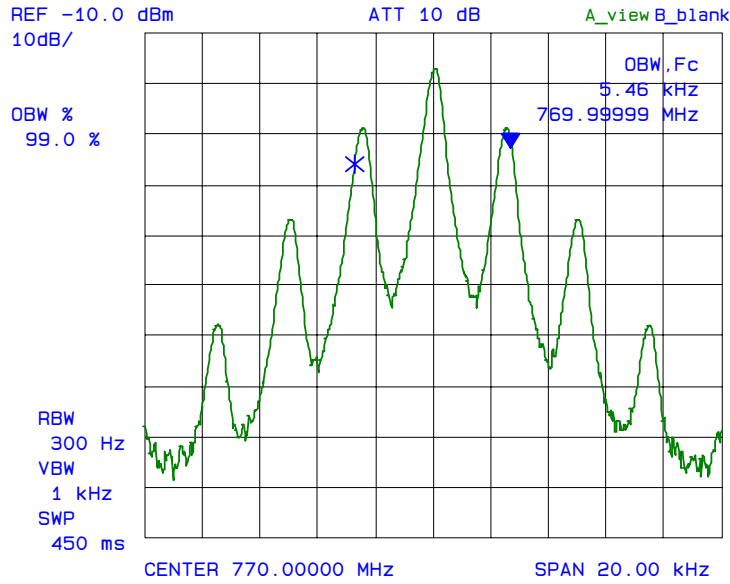

Plot 6.7.5.2.1.6: 99% Occupied Bandwidth (Output)
Fc: 770 MHz, Input Level: -15 dBm, Modulation: FM with 2.5 kHz sine wave signal

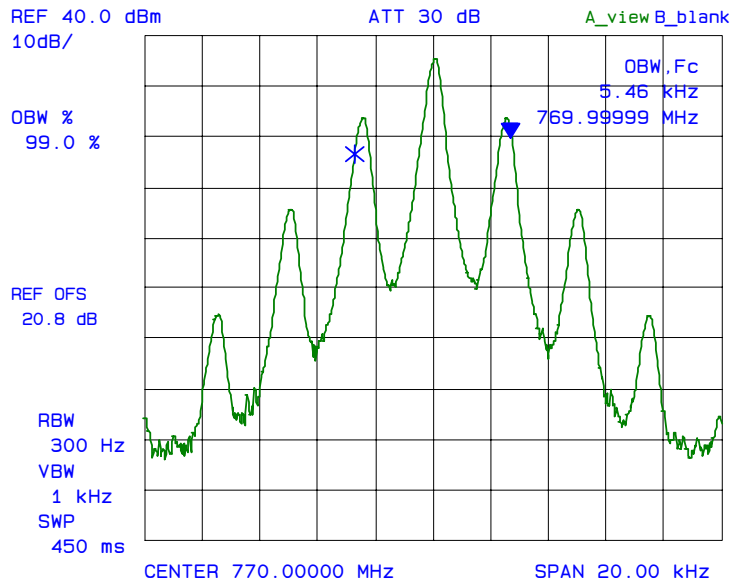

Plot 6.7.5.2.1.7: 99% Occupied Bandwidth (Input)
Fc: 770 MHz, Input Level: -15 dBm, Modulation: FM with an external 9600 bps random data source

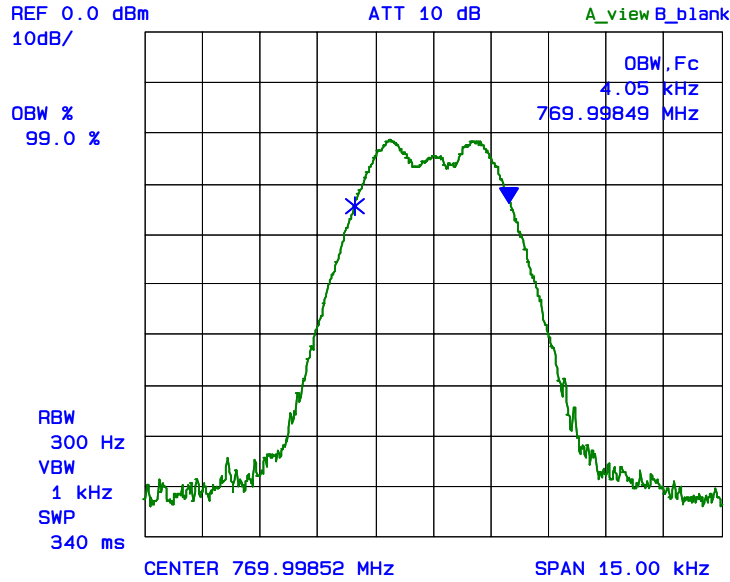

Plot 6.7.5.2.1.8: 99% Occupied Bandwidth (Output)
Fc: 770 MHz, Input Level: -15 dBm, Modulation: FM with an external 9600 bps random data source

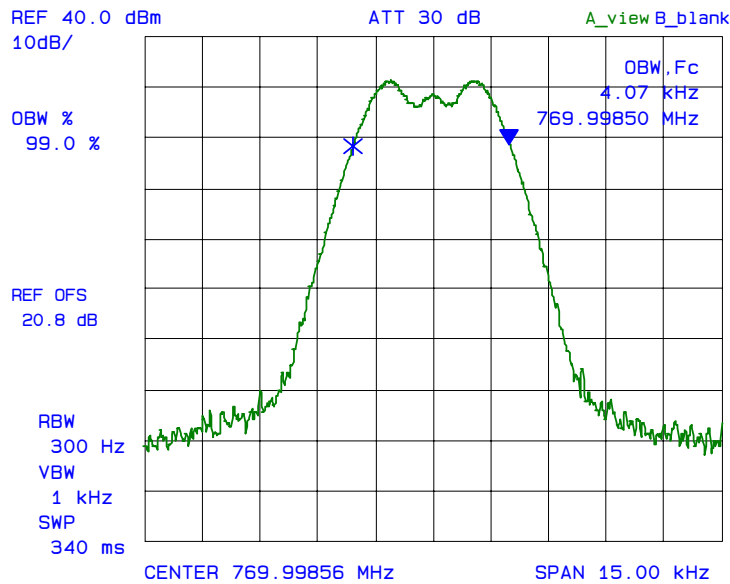

Plot 6.7.5.2.1.9: 99% Occupied Bandwidth (Input)
Fc: 776 MHz, Input Level: -15 dBm, Modulation: FM with 2.5 kHz sine wave signal

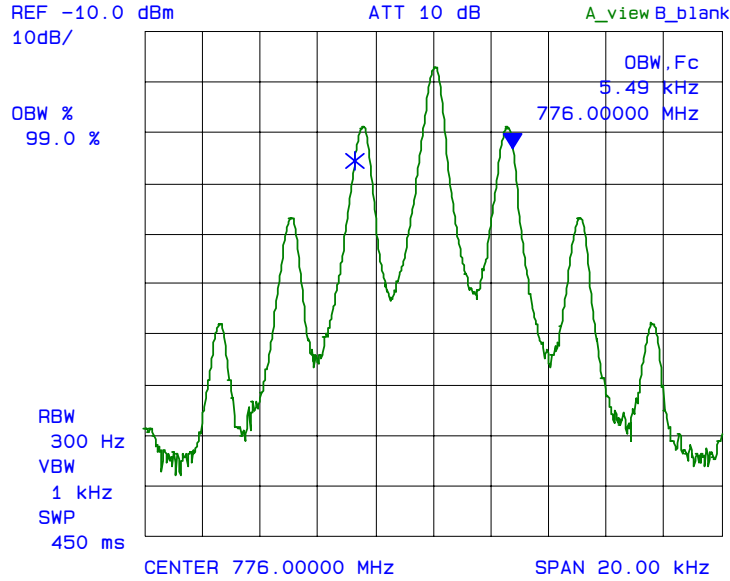

Plot 6.7.5.2.1.10: 99% Occupied Bandwidth (Output)
Fc: 776 MHz, Input Level: -15 dBm, Modulation: FM with 2.5 kHz sine wave signal

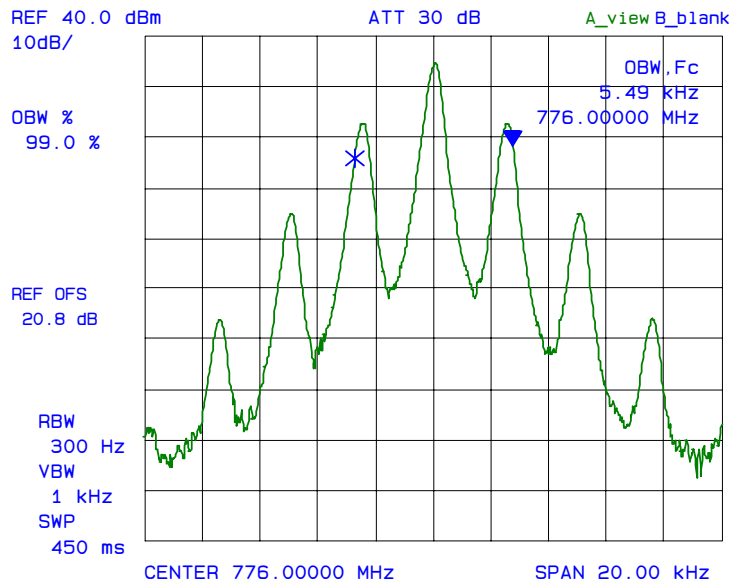

Plot 6.7.5.2.1.11: 99% Occupied Bandwidth (Input)
Fc: 776 MHz, Input Level: -15 dBm, Modulation: FM with an external 9600 bps random data source

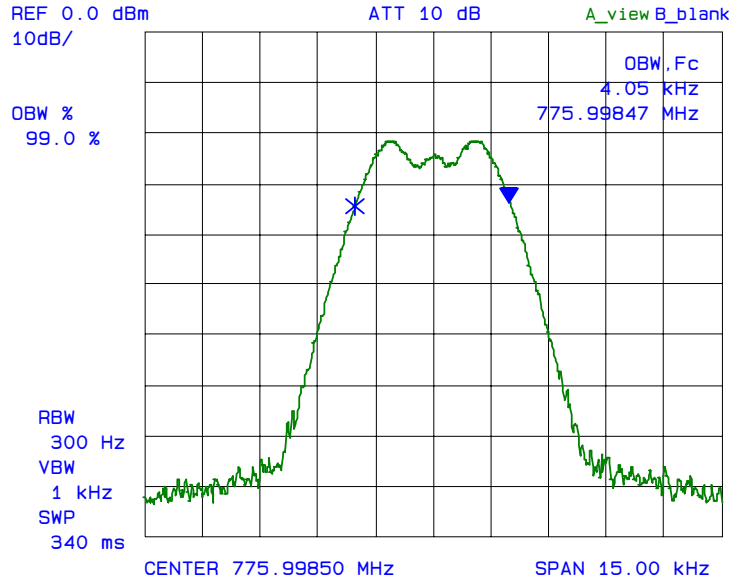

Plot 6.7.5.2.1.12: 99% Occupied Bandwidth (Output)
Fc: 776 MHz, Input Level: -15 dBm, Modulation: FM with an external 9600 bps random data source

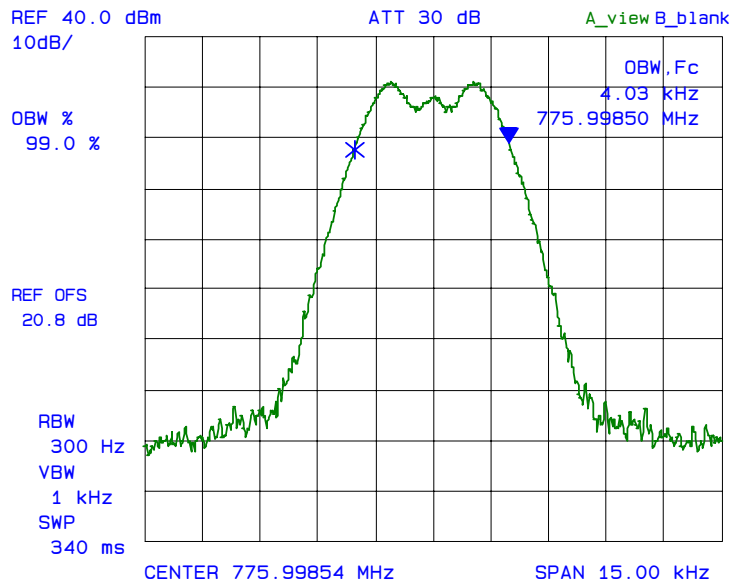

Plot 6.7.5.2.1.13: 99% Occupied Bandwidth (Input)
Fc: 794 MHz, Input Level: -15 dBm, Modulation: FM with 2.5 kHz sine wave signal

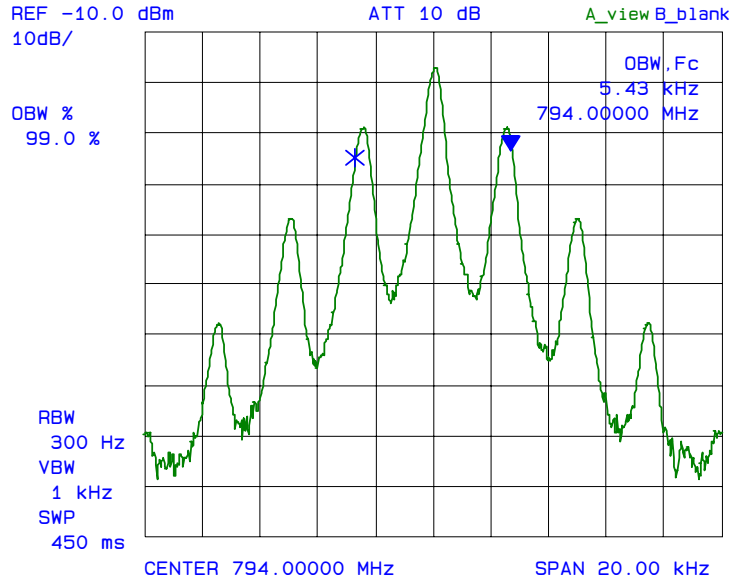

Plot 6.7.5.2.1.14: 99% Occupied Bandwidth (Output)
Fc: 794 MHz, Input Level: -15 dBm, Modulation: FM with 2.5 kHz sine wave signal

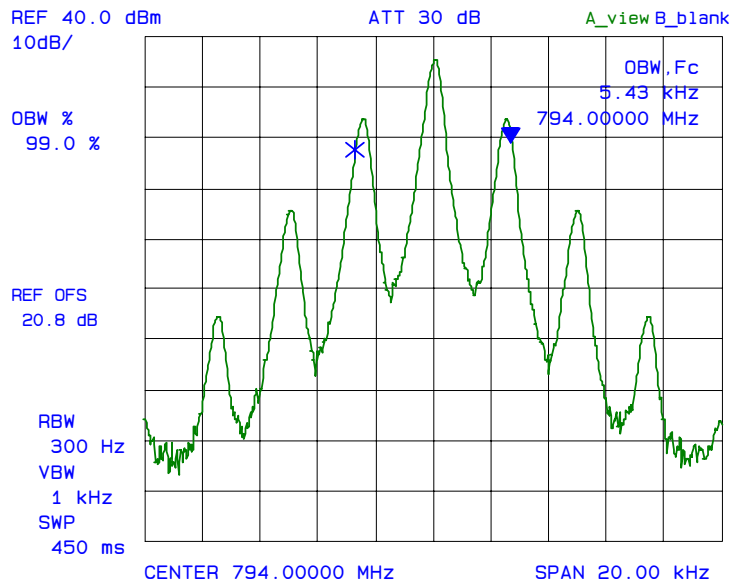

Plot 6.7.5.2.1.15: 99% Occupied Bandwidth (Input)
Fc: 794 MHz, Input Level: -15 dBm, Modulation: FM with an external 9600 bps random data source

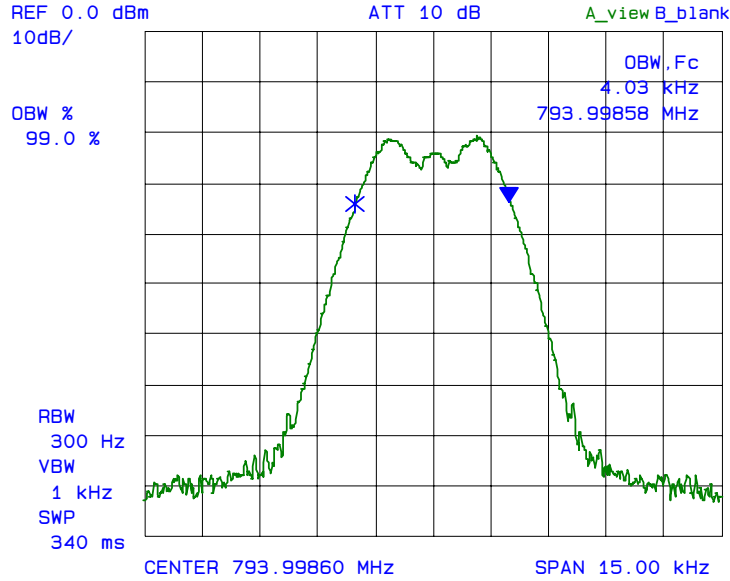

Plot 6.7.5.2.1.16: 99% Occupied Bandwidth (Output)
Fc: 794 MHz, Input Level: -15 dBm, Modulation: FM with an external 9600 bps random data source

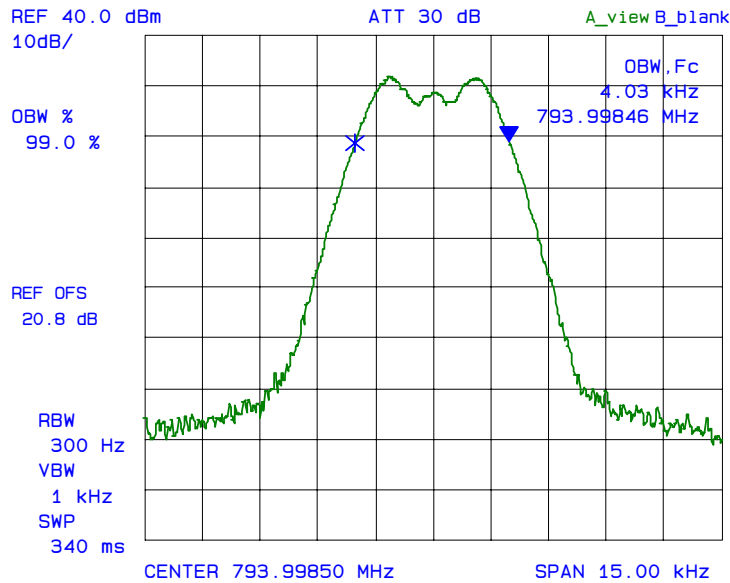

Plot 6.7.5.2.1.17: 99% Occupied Bandwidth (Input)
Fc: 800 MHz, Input Level: -15 dBm, Modulation: FM with 2.5 kHz sine wave signal

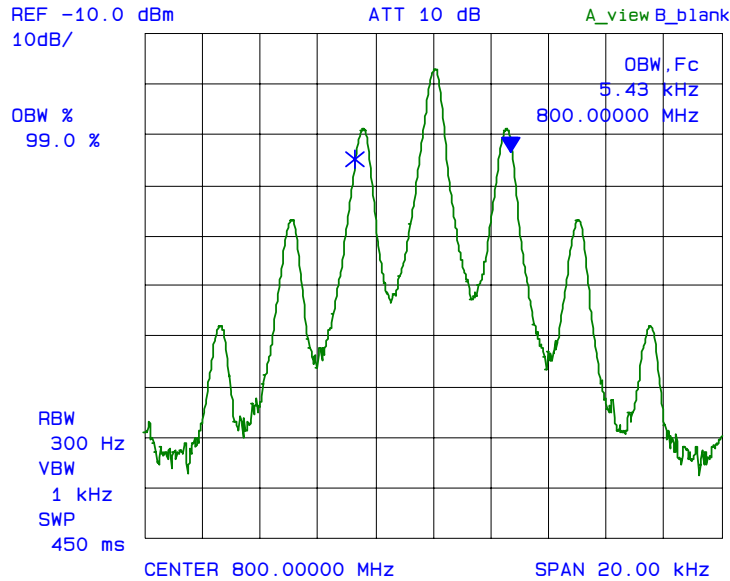

Plot 6.7.5.2.1.18: 99% Occupied Bandwidth (Output)
Fc: 800 MHz, Input Level: -15 dBm, Modulation: FM with 2.5 kHz sine wave signal

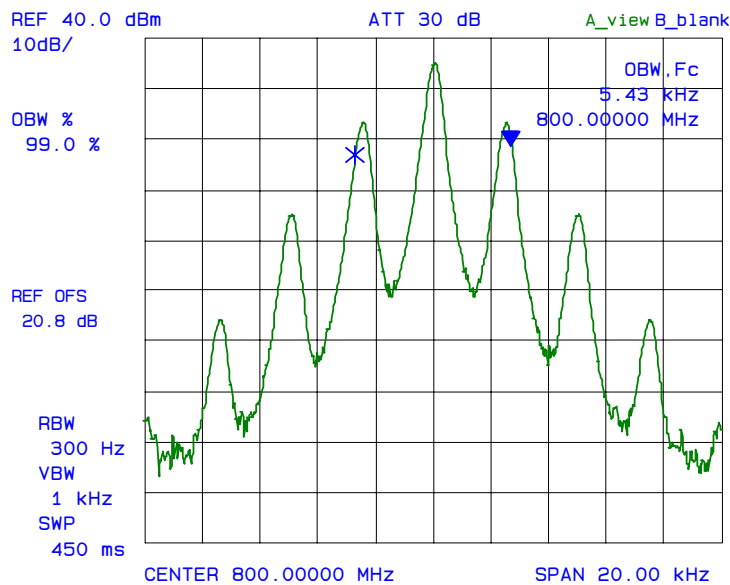

Plot 6.7.5.2.1.19: 99% Occupied Bandwidth (Input)
Fc: 800 MHz, Input Level: -15 dBm, Modulation: FM with an external 9600 bps random data source

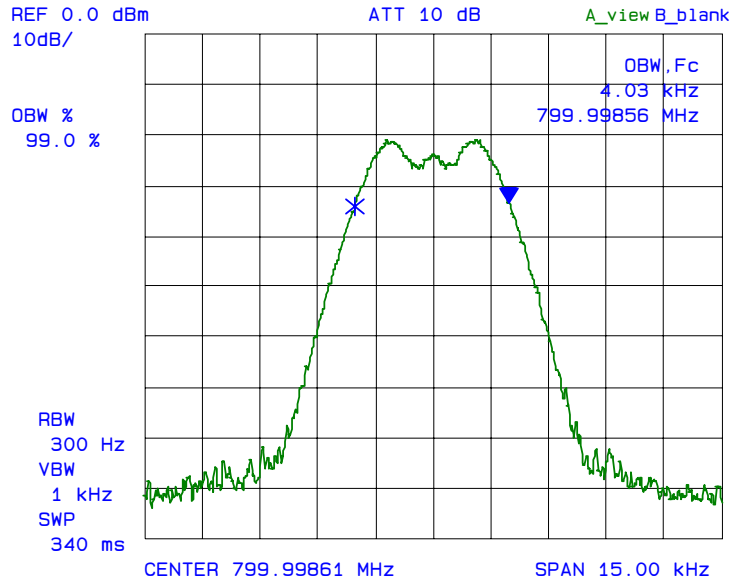

Plot 6.7.5.2.1.20: 99% Occupied Bandwidth (Output)
Fc: 800 MHz, Input Level: -15 dBm, Modulation: FM with an external 9600 bps random data source

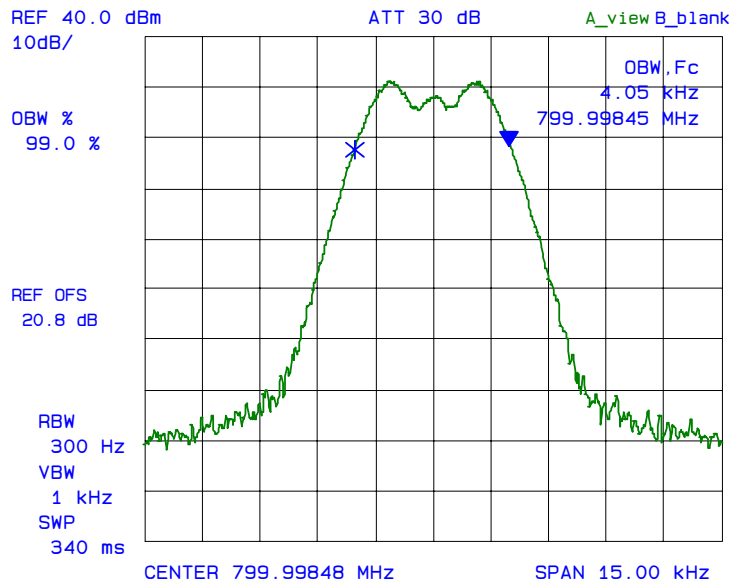

Plot 6.7.5.2.1.21: 99% Occupied Bandwidth (Input)
Fc: 806 MHz, Input Level: -15 dBm, Modulation: FM with 2.5 kHz sine wave signal

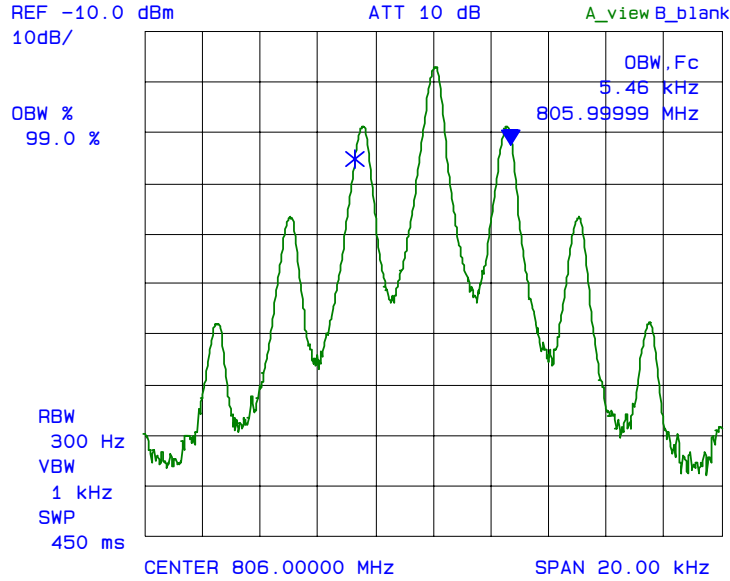

Plot 6.7.5.2.1.22: 99% Occupied Bandwidth (Output)
Fc: 806 MHz, Input Level: -15 dBm, Modulation: FM with 2.5 kHz sine wave signal

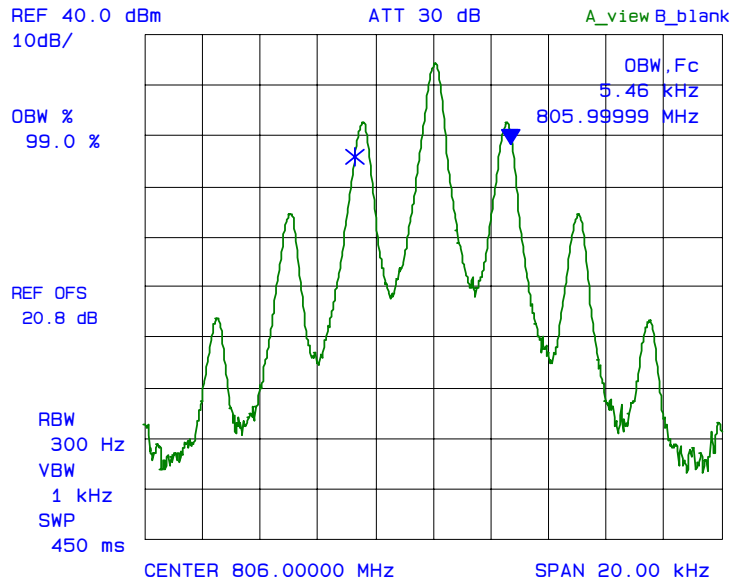

Plot 6.7.5.2.1.23: 99% Occupied Bandwidth (Input)
Fc: 806 MHz, Input Level: -15 dBm, Modulation: FM with an external 9600 bps random data source

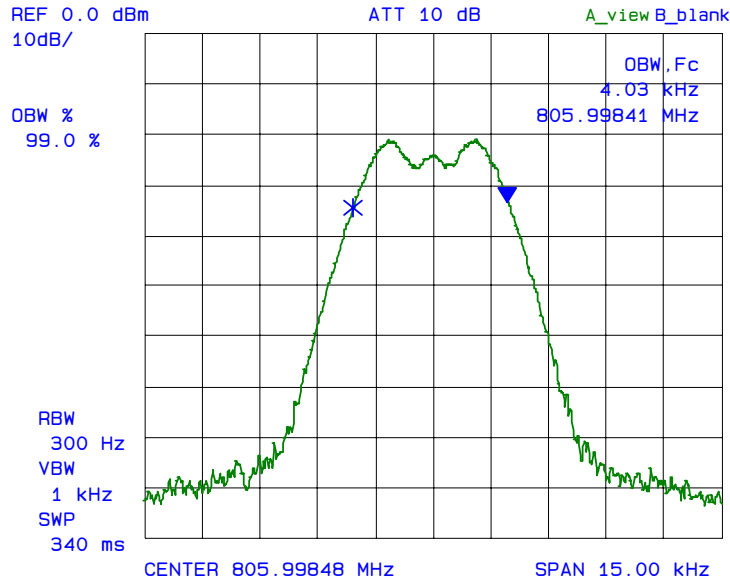

Plot 6.7.5.2.1.24: 99% Occupied Bandwidth (Output)
Fc: 806 MHz, Input Level: -15 dBm, Modulation: FM with an external 9600 bps random data source

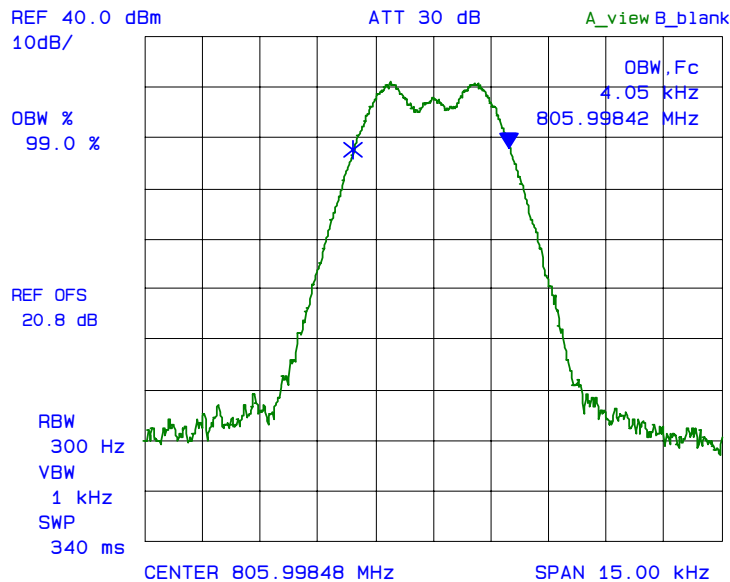

6.7.5.2.2. 12.5 kHz Channel Spacing

Plot 6.7.5.2.2.1: 99% Occupied Bandwidth (Input)
Fc: 764 MHz, Input Level: -15 dBm, Modulation: FM with 2.5 kHz sine wave signal

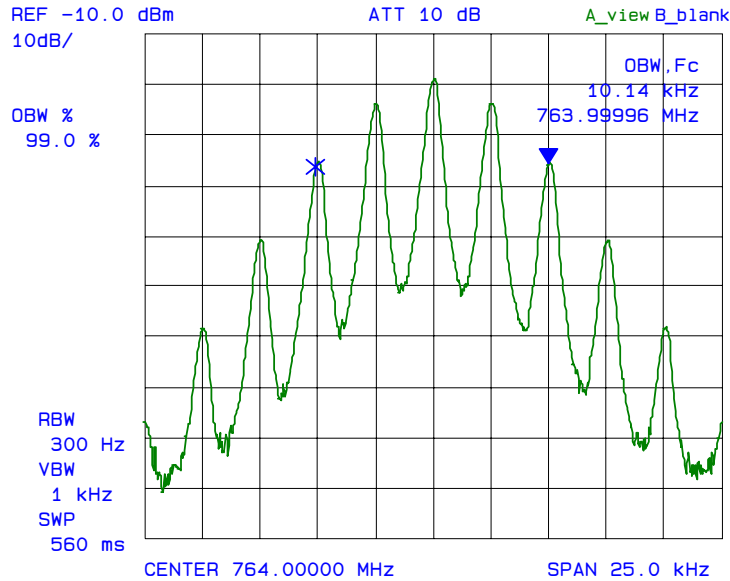

Plot 6.7.5.2.2.2: 99% Occupied Bandwidth (Output)
Fc: 764 MHz, Input Level: -15 dBm, Modulation: FM with 2.5 kHz sine wave signal

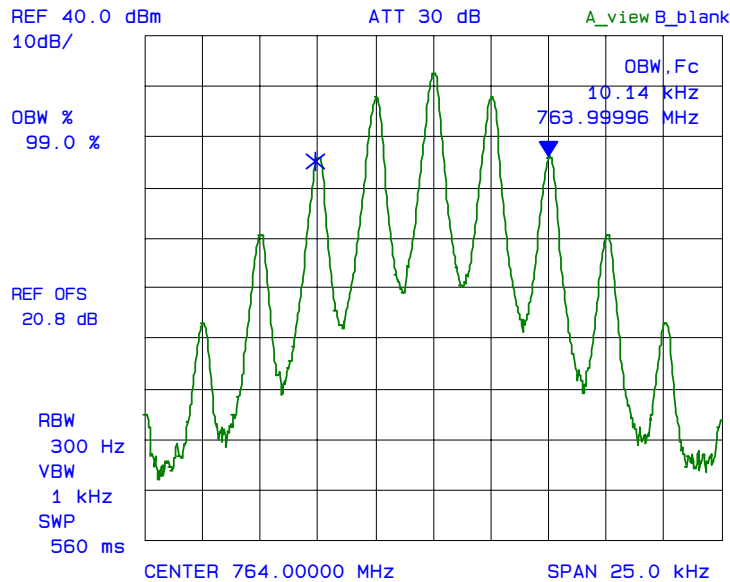

Plot 6.7.5.2.2.3: 99% Occupied Bandwidth (Input)
Fc: 764 MHz, Input Level: -15 dBm, Modulation: FM with an external 9600 bps random data source

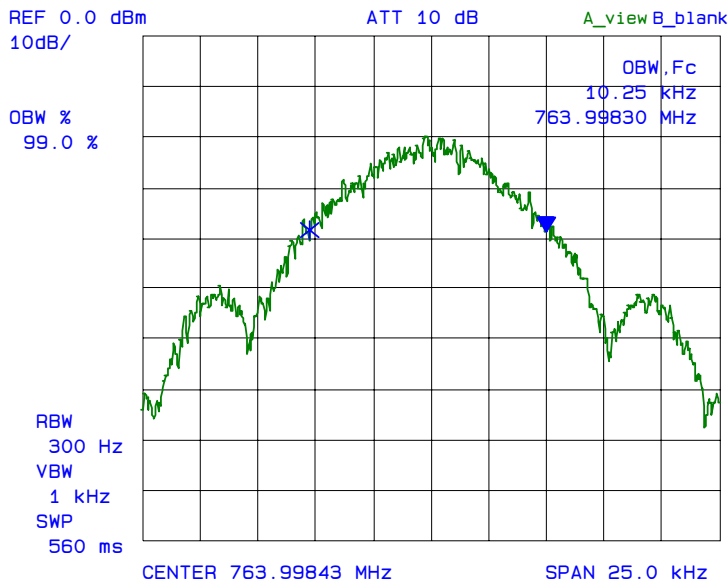

Plot 6.7.5.2.2.4: 99% Occupied Bandwidth (Output)
Fc: 764 MHz, Input Level: -15 dBm, Modulation: FM with an external 9600 bps random data source

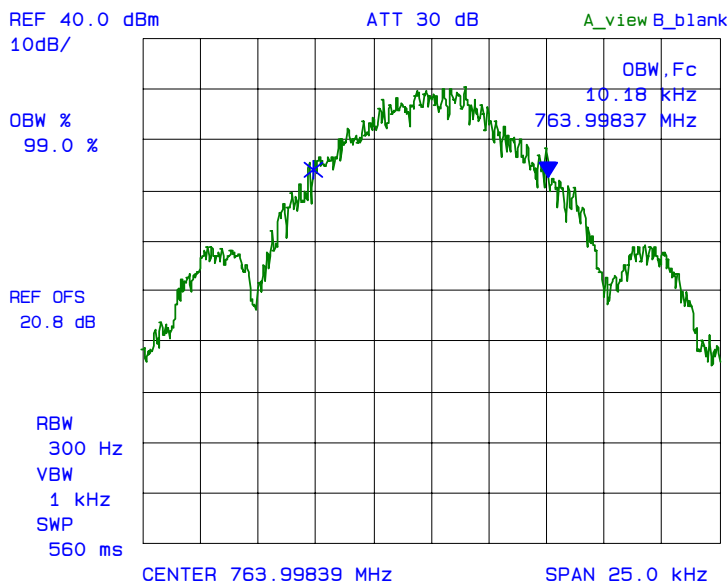

Plot 6.7.5.2.2.5: 99% Occupied Bandwidth (Input)
Fc: 770 MHz, Input Level: -15 dBm, Modulation: FM with 2.5 kHz sine wave signal.

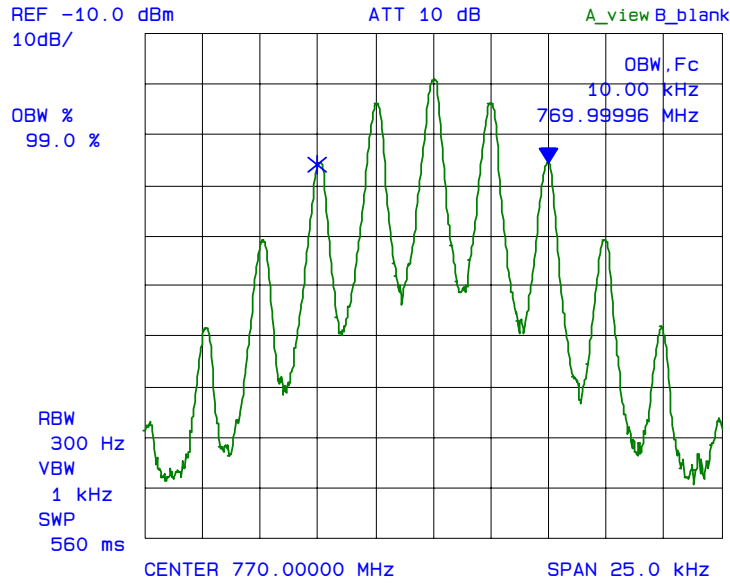

Plot 6.7.5.2.2.6: 99% Occupied Bandwidth (Output)
Fc: 770 MHz, Input Level: -15 dBm, Modulation: FM with 2.5 kHz sine wave signal.

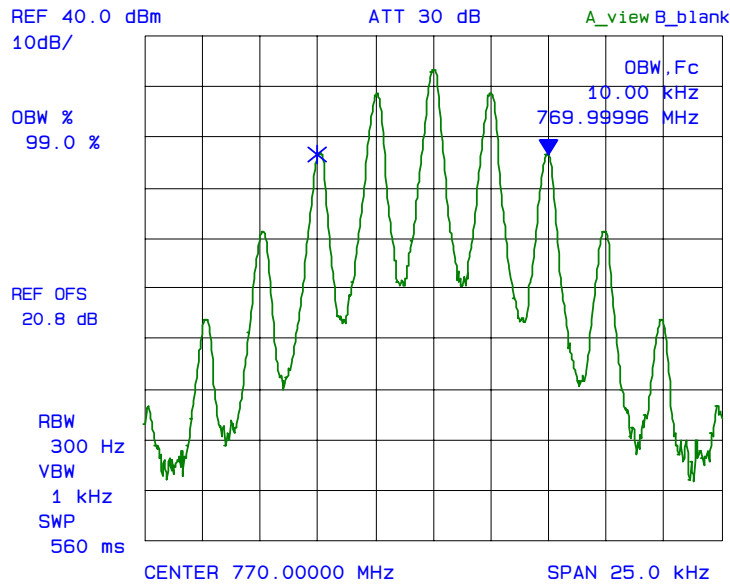

Plot 6.7.5.2.2.7: 99% Occupied Bandwidth (Input)
Fc: 770 MHz, Input Level: -15 dBm, Modulation: FM with an external 9600 bps random data source

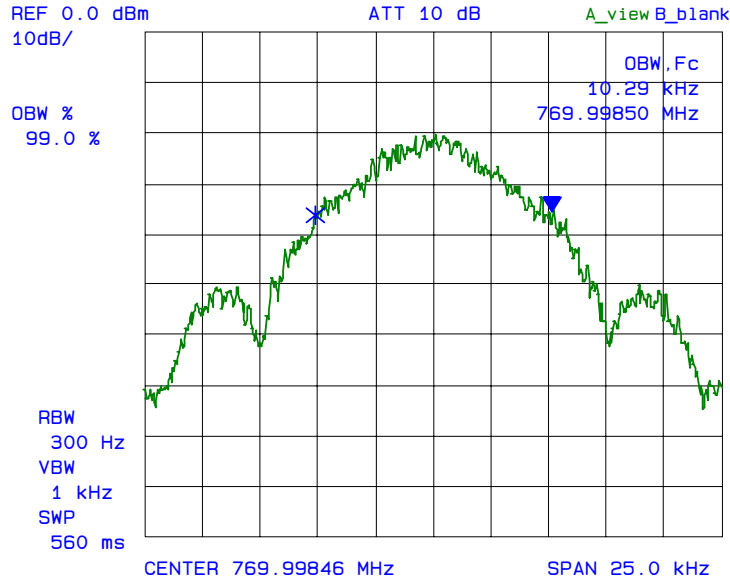

Plot 6.7.5.2.2.8: 99% Occupied Bandwidth (Output)
Fc: 770 MHz, Input Level: -15 dBm, Modulation: FM with an external 9600 bps random data source

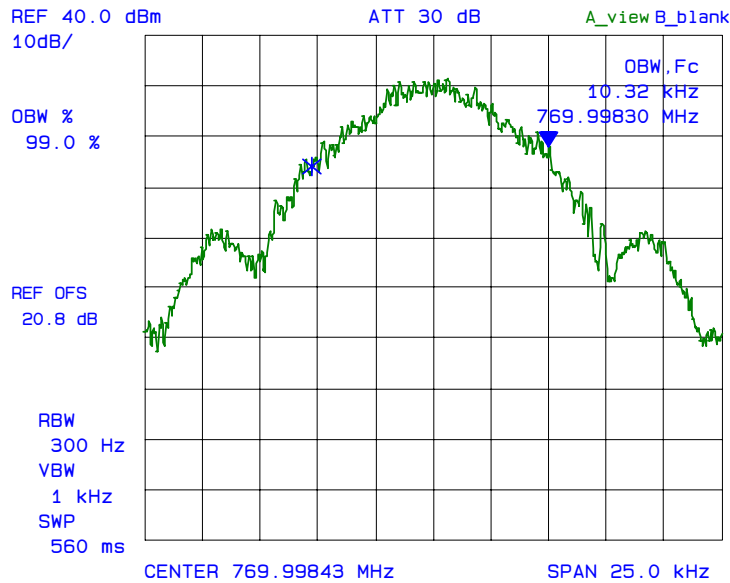

Plot 6.7.5.2.2.9: 99% Occupied Bandwidth (Input)
Fc: 776 MHz, Input Level: -15 dBm, Modulation: FM with 2.5 kHz sine wave signal

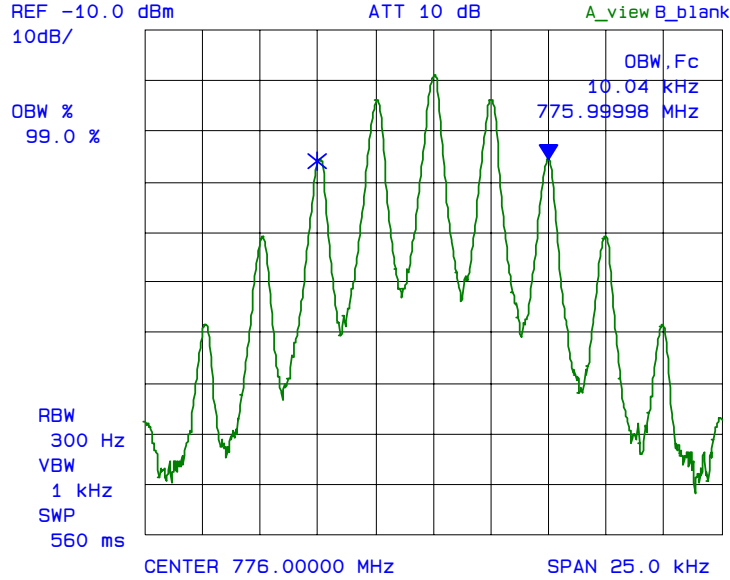

Plot 6.7.5.2.2.10: 99% Occupied Bandwidth (Output)
Fc: 776 MHz, Input Level: -15 dBm, Modulation: FM with 2.5 kHz sine wave signal

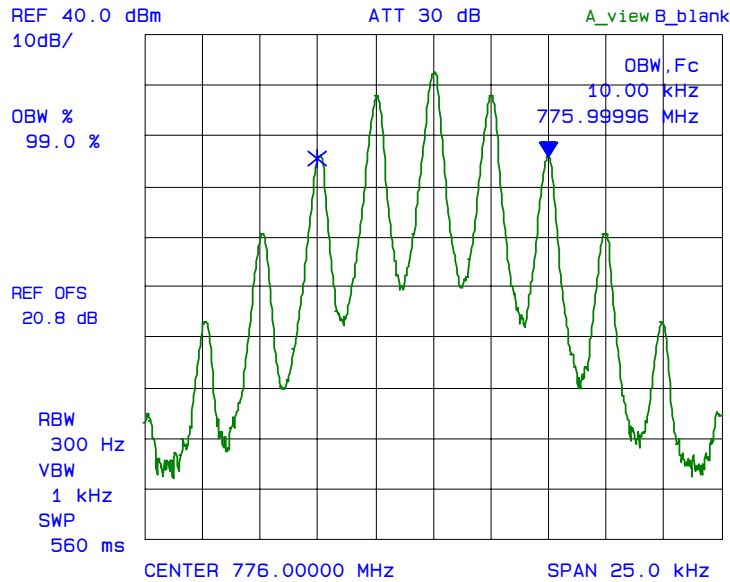

Plot 6.7.5.2.2.11: 99% Occupied Bandwidth (Input)
Fc: 776 MHz, Input Level: -15 dBm, Modulation: FM with an external 9600 bps random data source

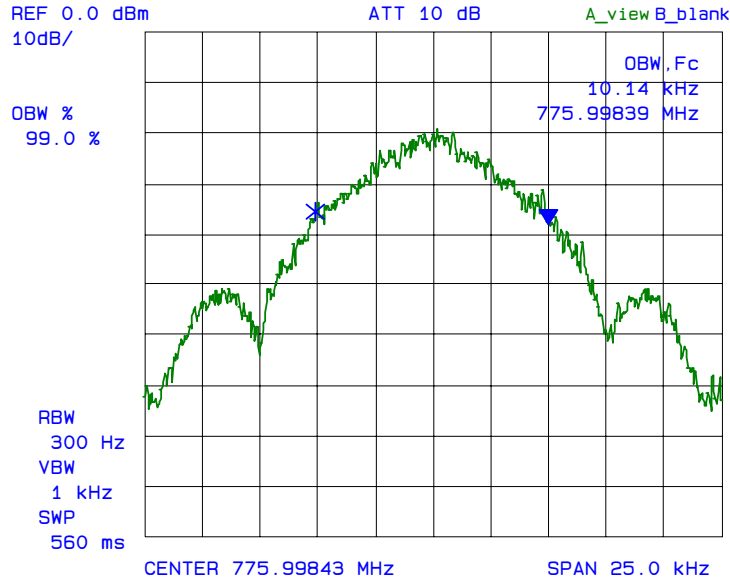

Plot 6.7.5.2.2.12: 99% Occupied Bandwidth (Output)
Fc: 776 MHz, Input Level: -15 dBm, Modulation: FM with an external 9600 bps random data source

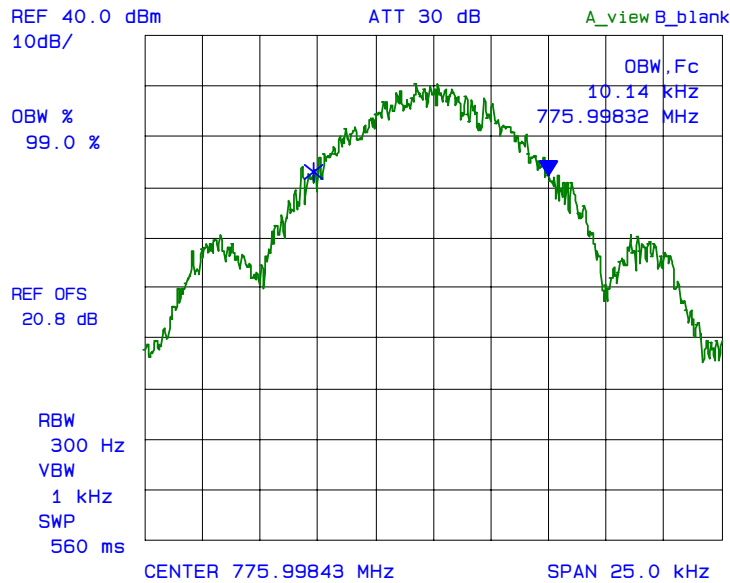

Plot 6.7.5.2.2.13: 99% Occupied Bandwidth (Input)
Fc: 794 MHz, Input Level: -15 dBm, Modulation: FM with 2.5 kHz sine wave signal

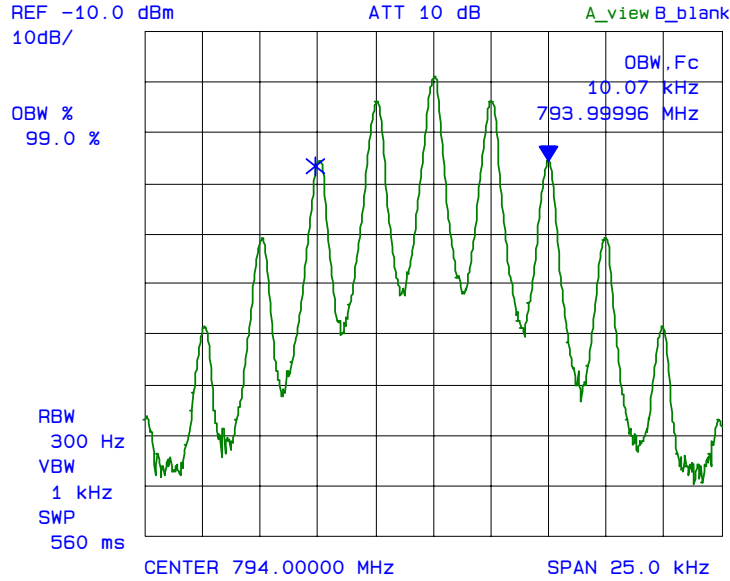

Plot 6.7.5.2.2.14: 99% Occupied Bandwidth (Output)
Fc: 794 MHz, Input Level: -15 dBm, Modulation: FM with 2.5 kHz sine wave signal

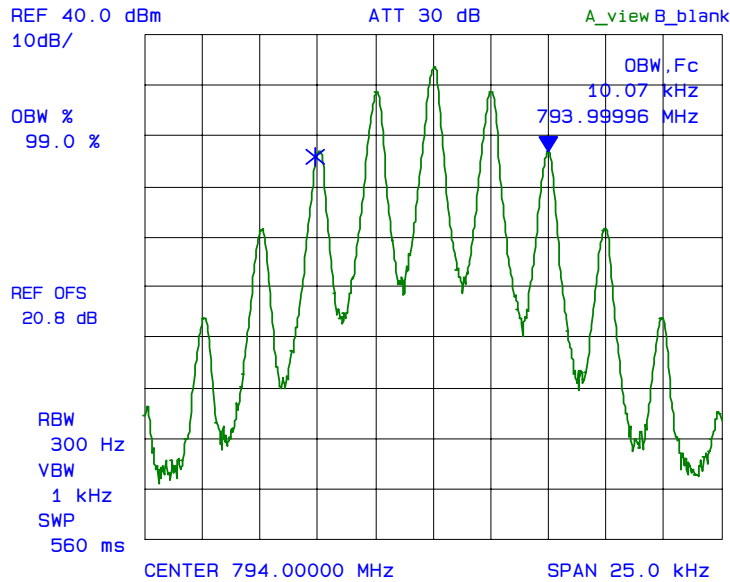

Plot 6.7.5.2.2.15: 99% Occupied Bandwidth (Input)
Fc: 794 MHz, Input Level: -15 dBm, Modulation: FM with an external 9600 bps random data source

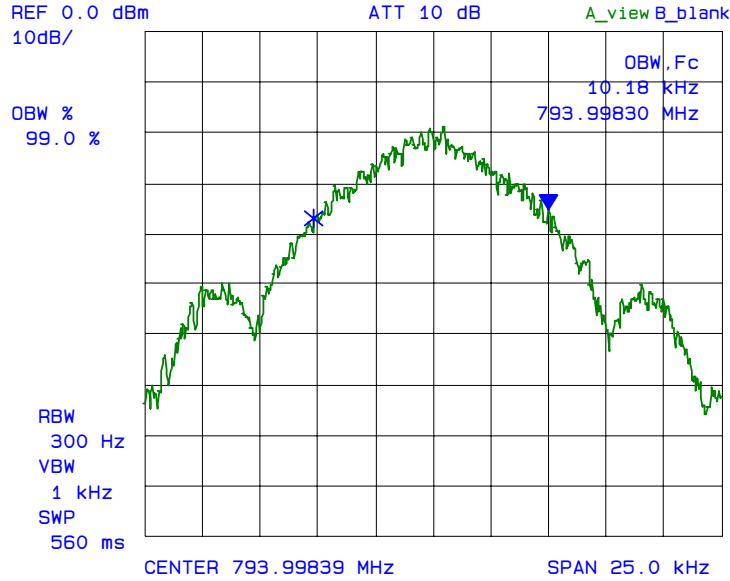

Plot 6.7.5.2.2.16: 99% Occupied Bandwidth (Output)
Fc: 794 MHz, Input Level: -15 dBm, Modulation: FM with an external 9600 bps random data source

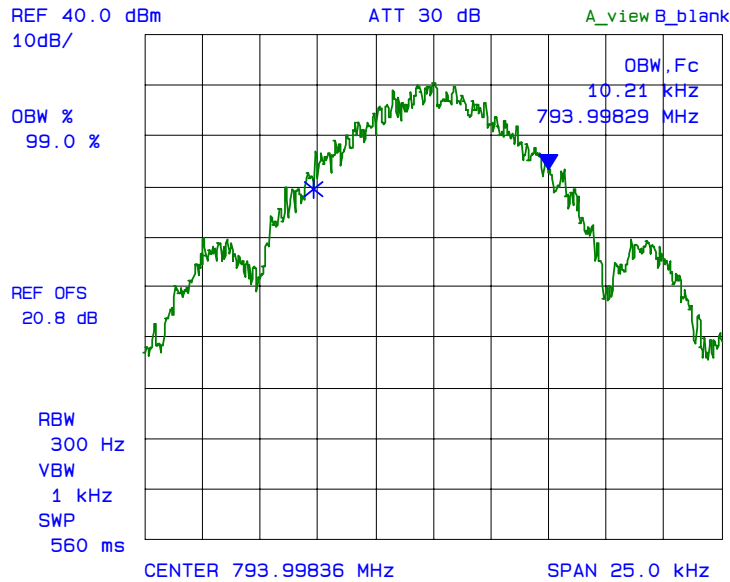

Plot 6.7.5.2.2.17: 99% Occupied Bandwidth (Input)
Fc: 800 MHz, Input Level: -15 dBm, Modulation: FM with 2.5 kHz sine wave signal

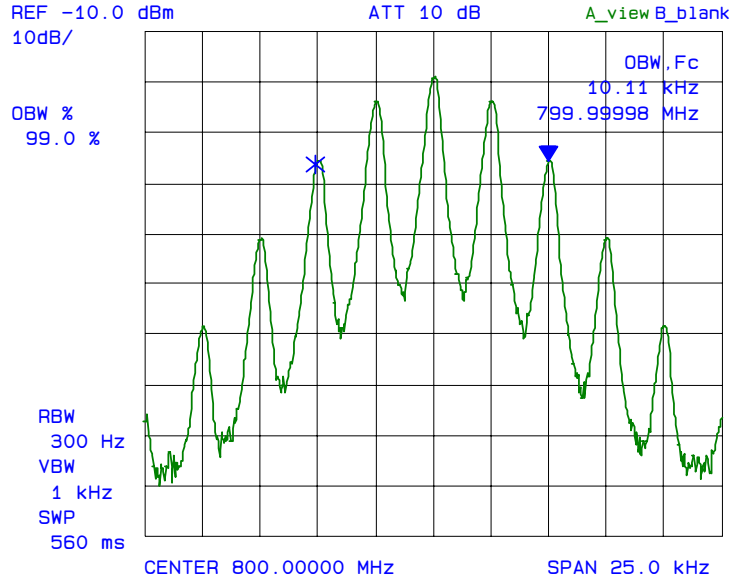

Plot 6.7.5.2.2.18: 99% Occupied Bandwidth (Output)
Fc: 800 MHz, Input Level: -15 dBm, Modulation: FM with 2.5 kHz sine wave signal

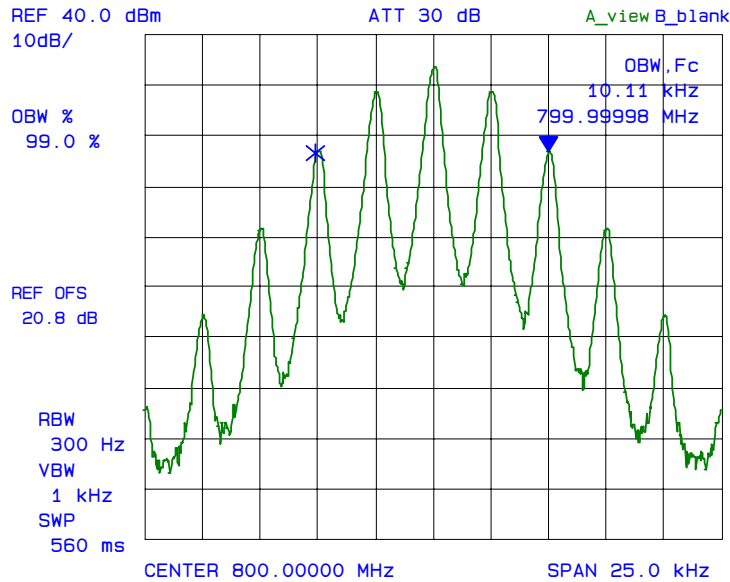

Plot 6.7.5.2.2.19: 99% Occupied Bandwidth (Input)
Fc: 800 MHz, Input Level: -15 dBm, Modulation: FM with an external 9600 bps random data source

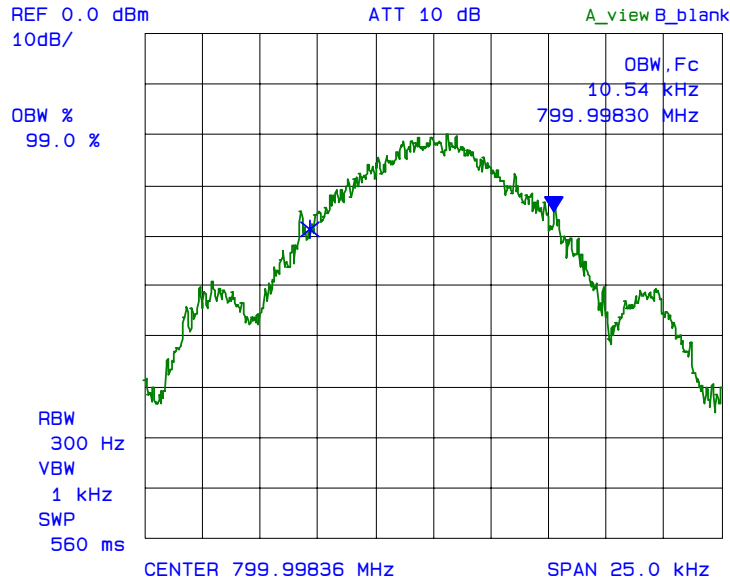

Plot 6.7.5.2.2.20: 99% Occupied Bandwidth (Output)
Fc: 800 MHz, Input Level: -15 dBm, Modulation: FM with an external 9600 bps random data source.

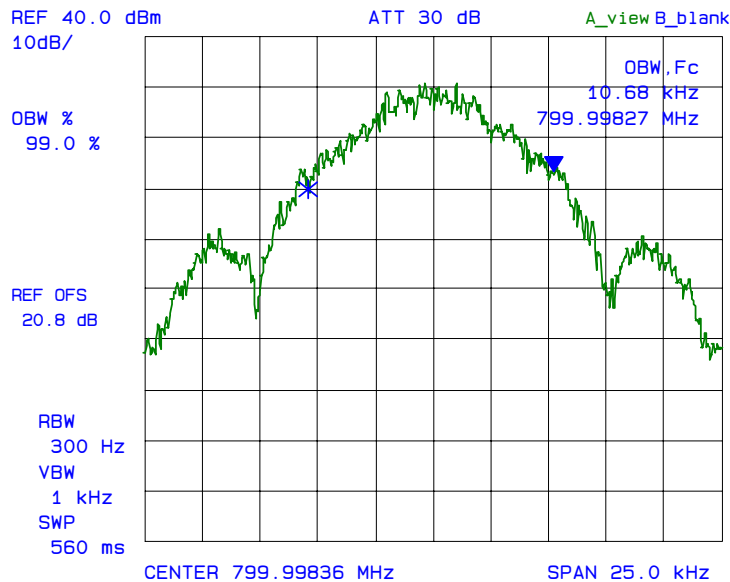

Plot 6.7.5.2.2.21: 99% Occupied Bandwidth (Input)
Fc: 806 MHz, Input Level: -15 dBm, Modulation: FM with 2.5 kHz sine wave signal

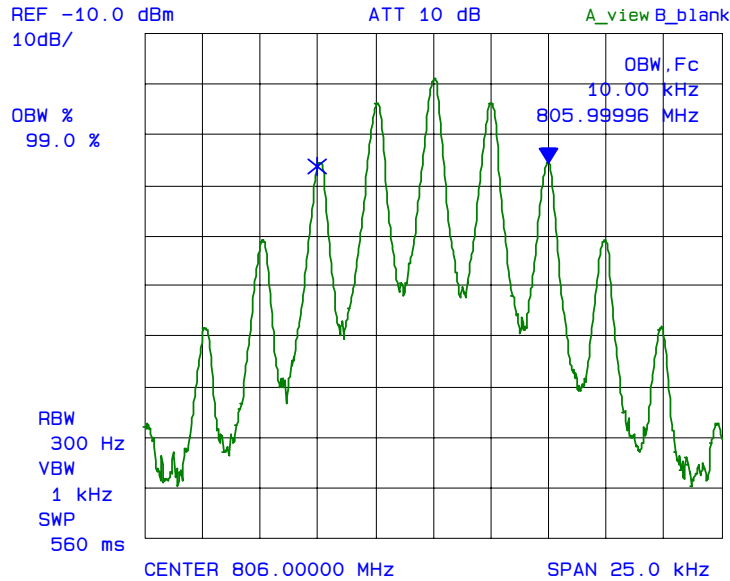

Plot 6.7.5.2.2.22: 99% Occupied Bandwidth (Output)
Fc: 806 MHz, Input Level: -15 dBm, Modulation: FM with 2.5 kHz sine wave signal.

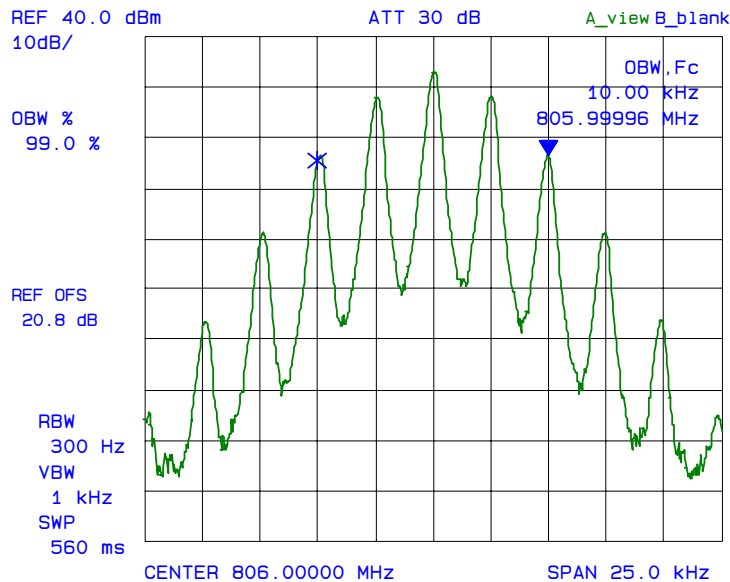

Plot 6.7.5.2.2.23: 99% Occupied Bandwidth (Input)
Fc: 806 MHz, Input Level: -15 dBm, Modulation: FM with an external 9600 bps random data source

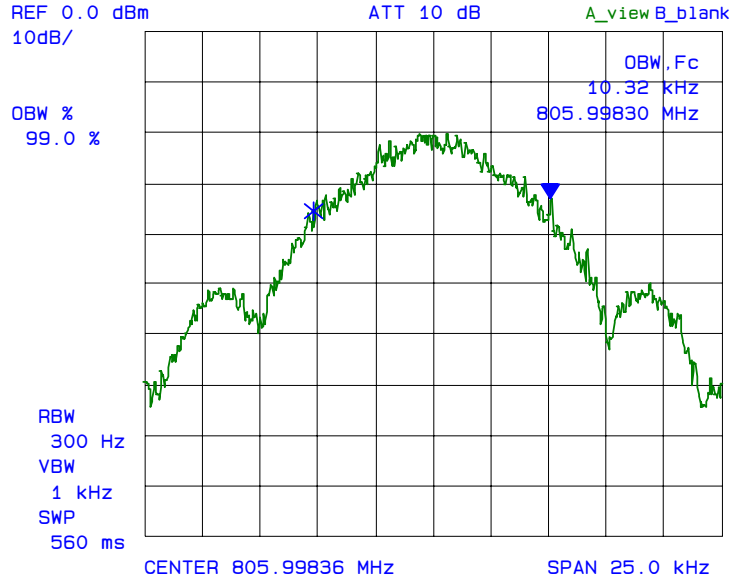

Plot 6.7.5.2.2.24: 99% Occupied Bandwidth (Output)
Fc: 806 MHz, Input Level: -15 dBm, Modulation: FM with an external 9600 bps random data source

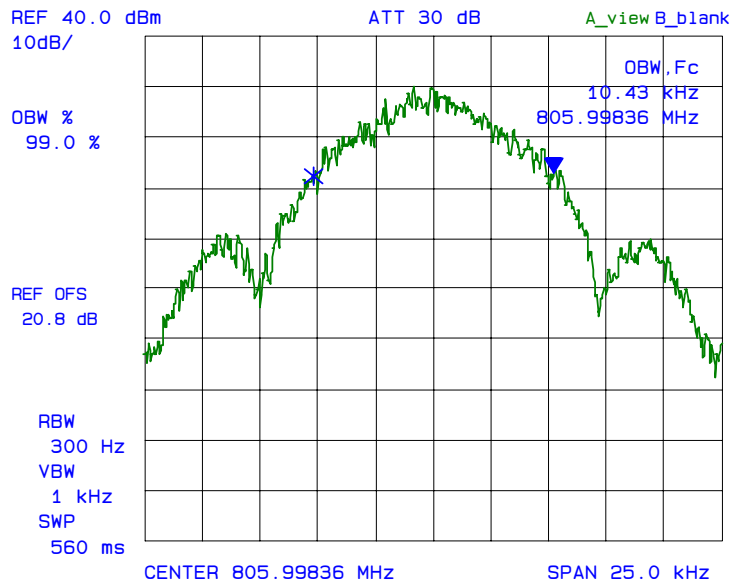

6.7.5.2.3. 25 kHz Channel Spacing

Plot 6.7.5.2.3.1: 99% Occupied Bandwidth (Input)
Fc: 764 MHz, Input Level: -15 dBm, Modulation: FM with 2.5 kHz sine wave signal

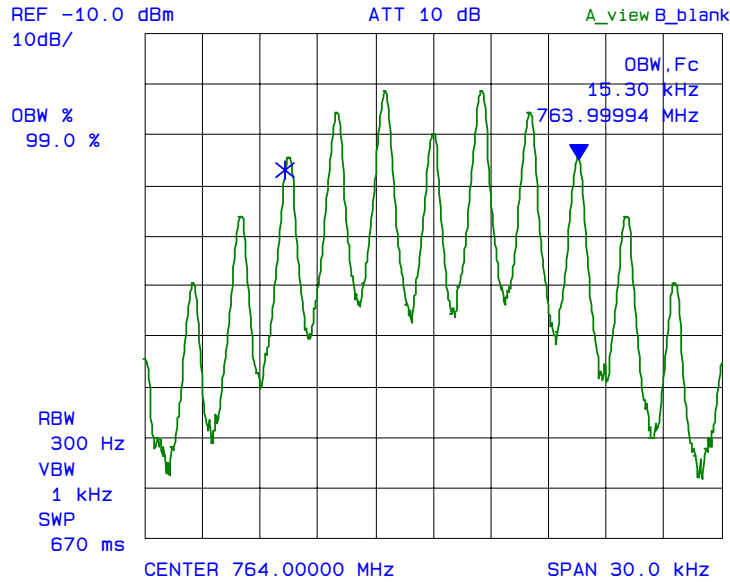

Plot 6.7.5.2.3.2: 99% Occupied Bandwidth (Output)
Fc: 764 MHz, Input Level: -15 dBm, Modulation: FM with 2.5 kHz sine wave signal

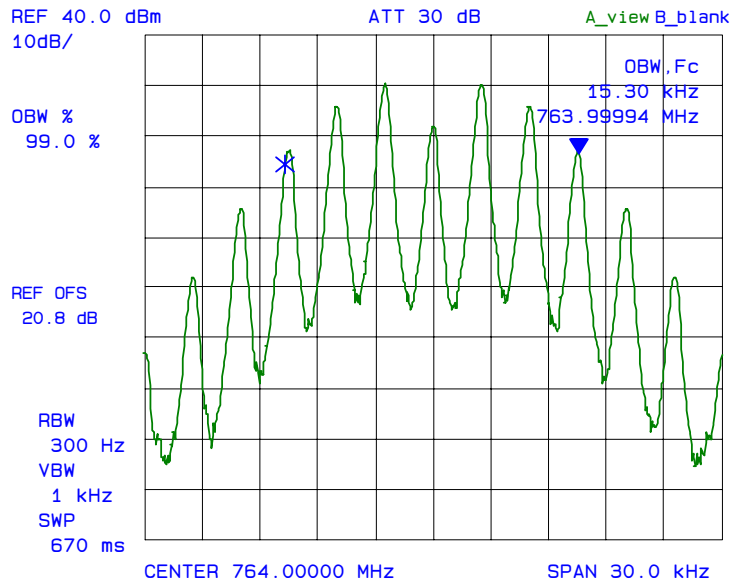

Plot 6.7.5.2.3.3: 99% Occupied Bandwidth (Input)
Fc: 764 MHz, Input Level: -15 dBm, Modulation: FM with an external 9600 bps random data source.

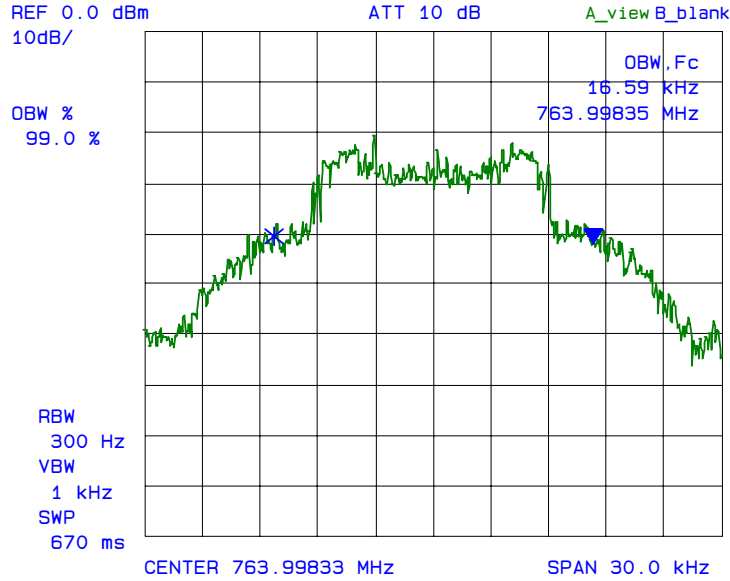

Plot 6.7.5.2.3.4: 99% Occupied Bandwidth (Output)
Fc: 764 MHz, Input Level: -15 dBm, Modulation: FM with an external 9600 bps random data source

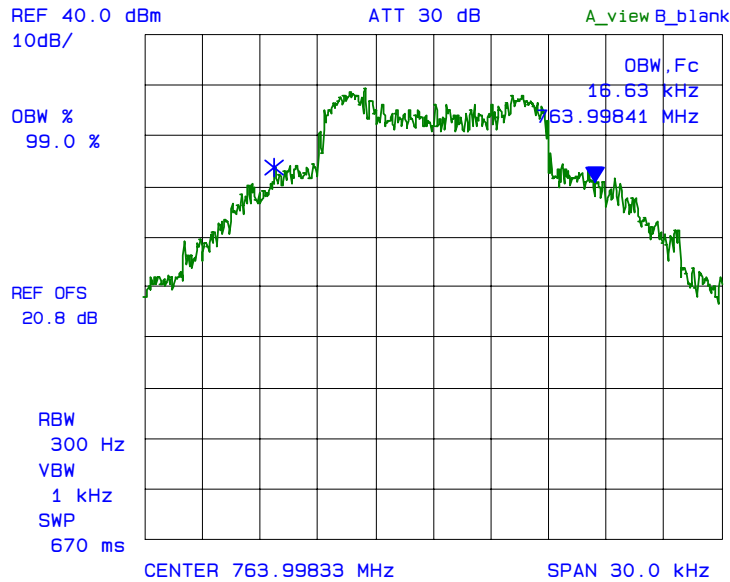

Plot 6.7.5.2.3.5: 99% Occupied Bandwidth (Input)
Fc: 770 MHz, Input Level: -15 dBm, Modulation: FM with 2.5 kHz sine wave signal

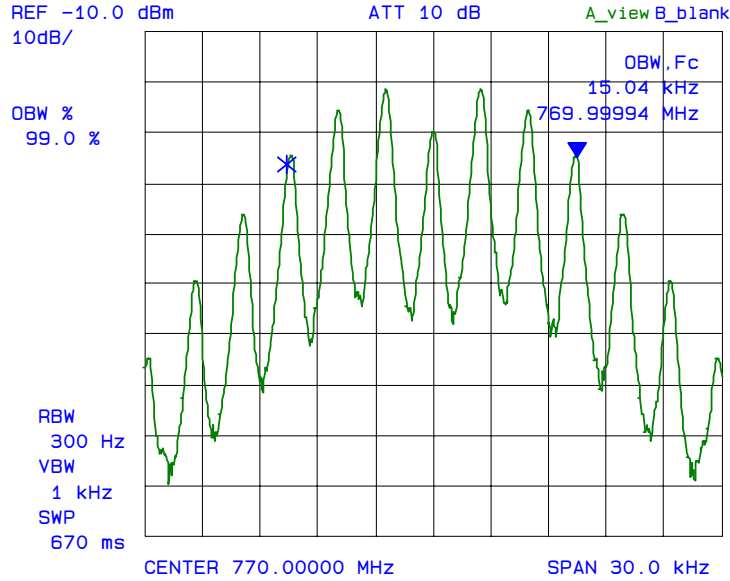

Plot 6.7.5.2.3.6: 99% Occupied Bandwidth (Output)
Fc: 770 MHz, Input Level: -15 dBm, Modulation: FM with 2.5 kHz sine wave signal

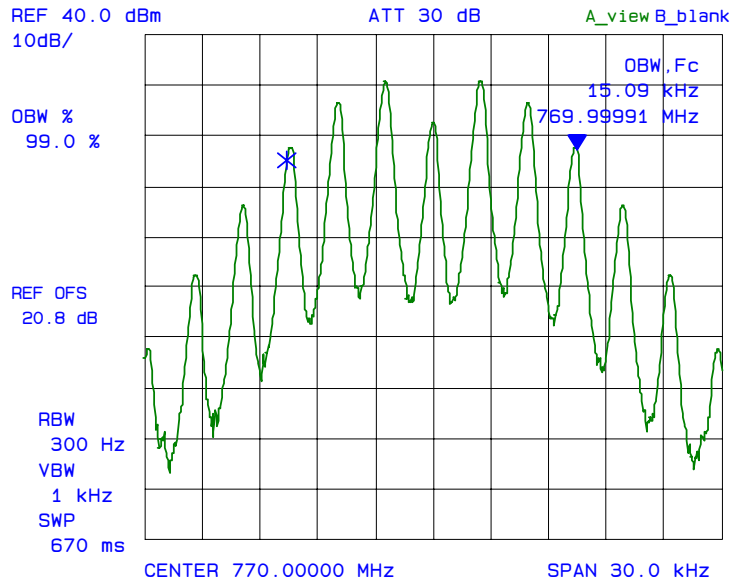

Plot 6.7.5.2.3.7: 99% Occupied Bandwidth (Input)
Fc: 770 MHz, Input Level: -15 dBm, Modulation: FM with an external 9600 bps random data source

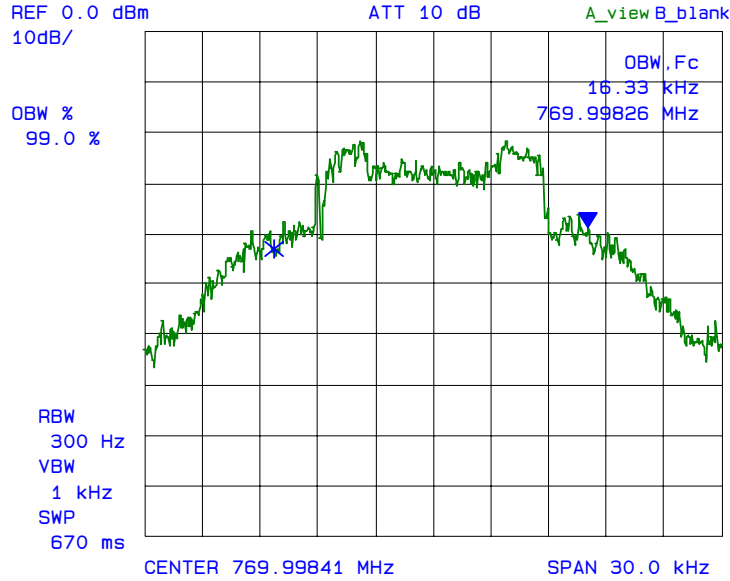

Plot 6.7.5.2.3.8: 99% Occupied Bandwidth (Output)
Fc: 770 MHz, Input Level: -15 dBm, Modulation: FM with an external 9600 bps random data source

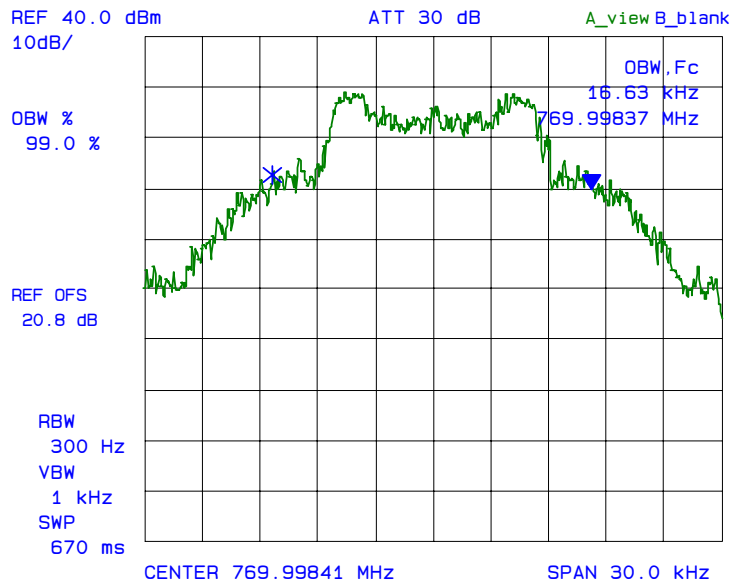

Plot 6.7.5.2.3.9: 99% Occupied Bandwidth (Input)
Fc: 776 MHz, Input Level: -15 dBm, Modulation: FM with 2.5 kHz sine wave signal

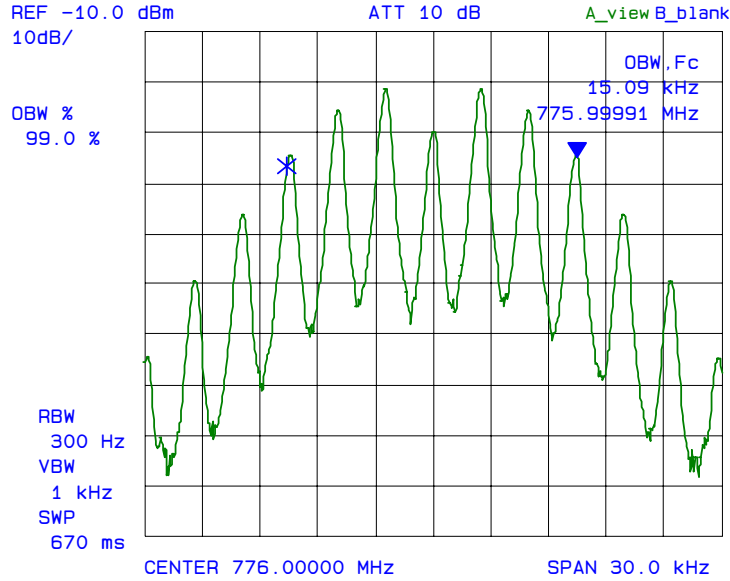

Plot 6.7.5.2.3.10: 99% Occupied Bandwidth (Output)
Fc: 776 MHz, Input Level: -15 dBm, Modulation: FM with 2.5 kHz sine wave signal

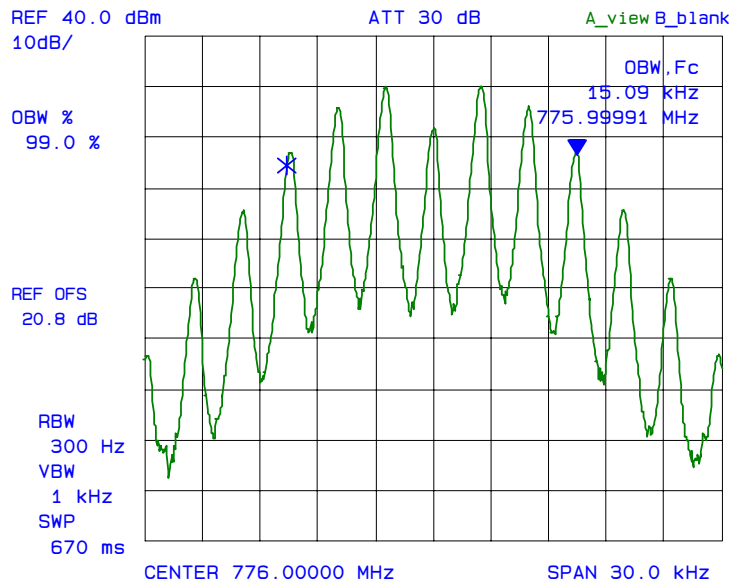

Plot 6.7.5.2.3.11: 99% Occupied Bandwidth (Input)
Fc: 776 MHz, Input Level: -15 dBm, Modulation: FM with an external 9600 bps random data source

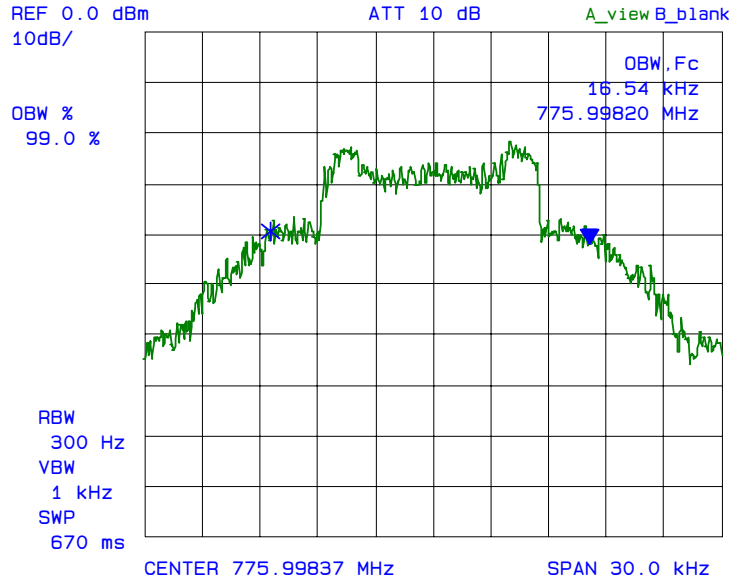

Plot 6.7.5.2.3.12: 99% Occupied Bandwidth (Output)
Fc: 776 MHz, Input Level: -15 dBm, Modulation: FM with an external 9600 bps random data source

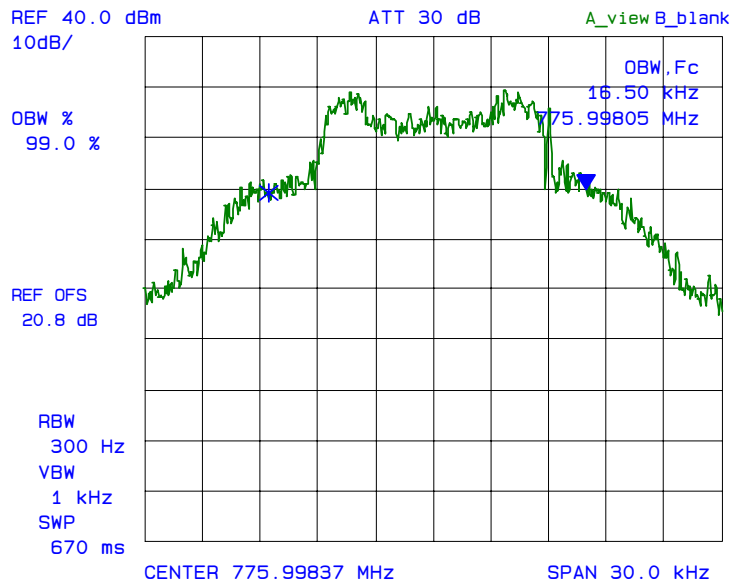

Plot 6.7.5.2.3.13: 99% Occupied Bandwidth (Input)
Fc: 794 MHz, Input Level: -15 dBm, Modulation: FM with 2.5 kHz sine wave signal

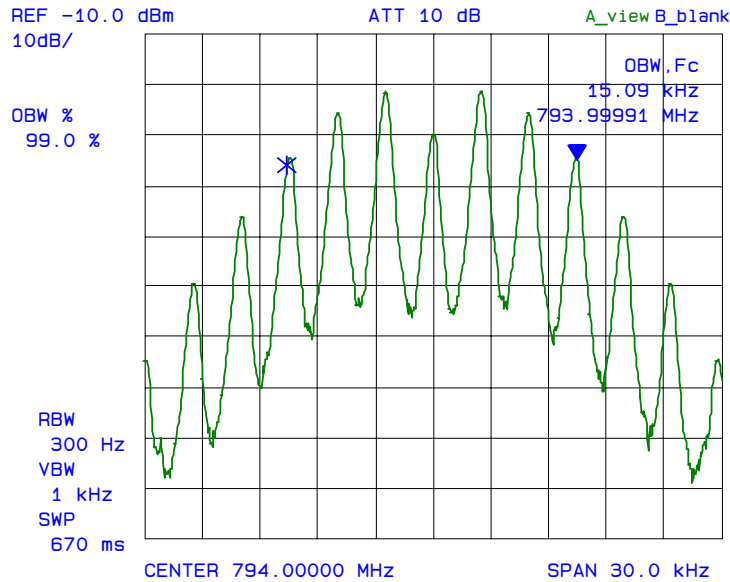

Plot 6.7.5.2.3.14: 99% Occupied Bandwidth (Output)
Fc: 794 MHz, Input Level: -15 dBm, Modulation: FM with 2.5 kHz sine wave signal

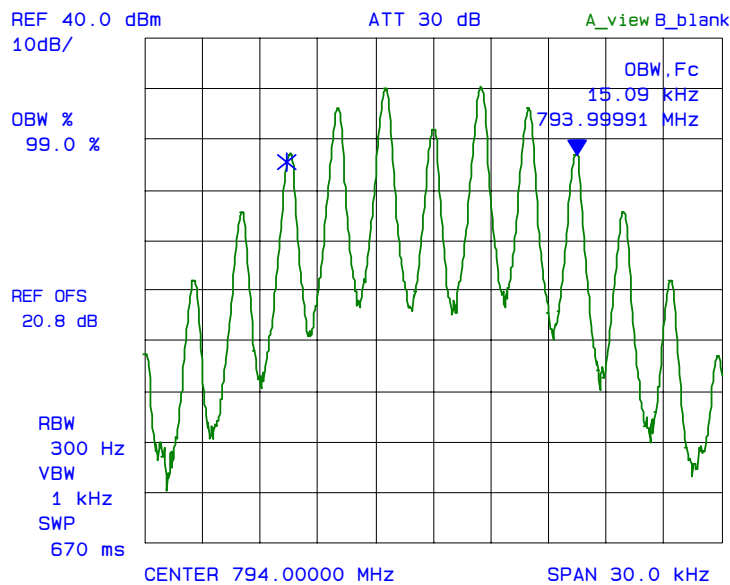

Plot 6.7.5.2.3.15: 99% Occupied Bandwidth (Input)
Fc: 794 MHz, Input Level: -15 dBm, Modulation: FM with an external 9600 bps random data source

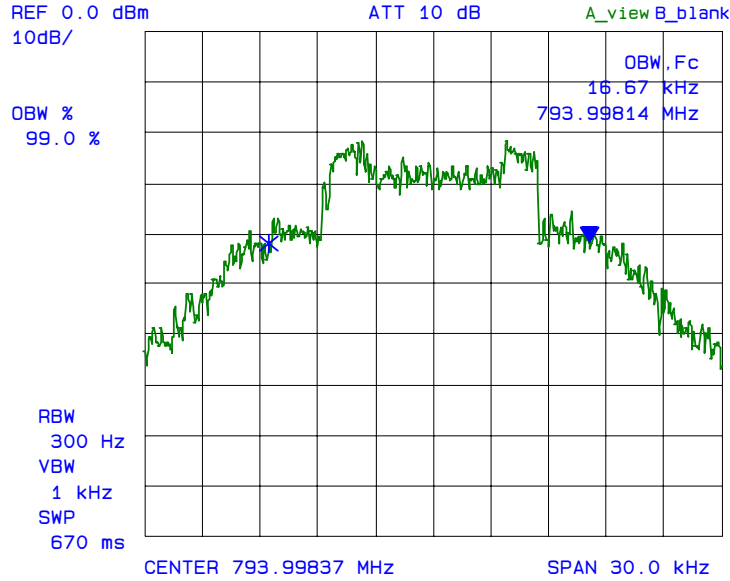

Plot 6.7.5.2.3.16: 99% Occupied Bandwidth (Output)
Fc: 794 MHz, Input Level: -15 dBm, Modulation: FM with an external 9600 bps random data source

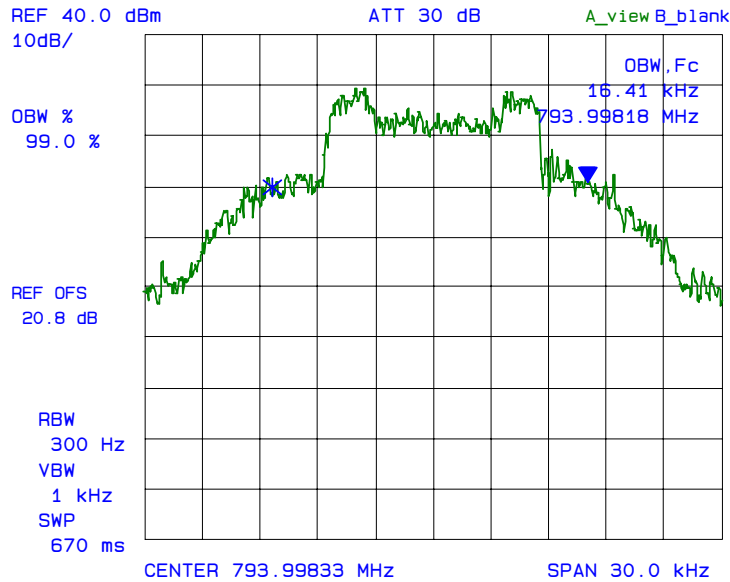

Plot 6.7.5.2.3.17: 99% Occupied Bandwidth (Input)
Fc: 800 MHz, Input Level: -15 dBm, Modulation: FM with 2.5 kHz sine wave signal

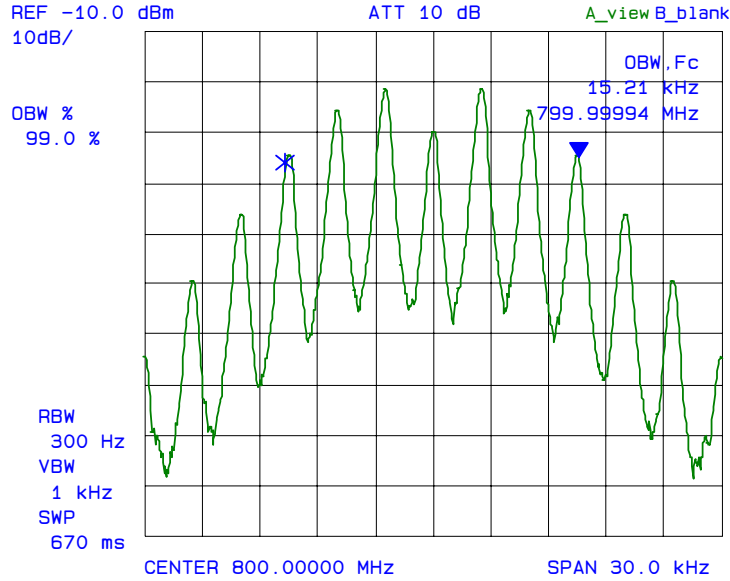

Plot 6.7.5.2.3.18: 99% Occupied Bandwidth (Output)
Fc: 800 MHz, Input Level: -15 dBm, Modulation: FM with 2.5 kHz sine wave signal

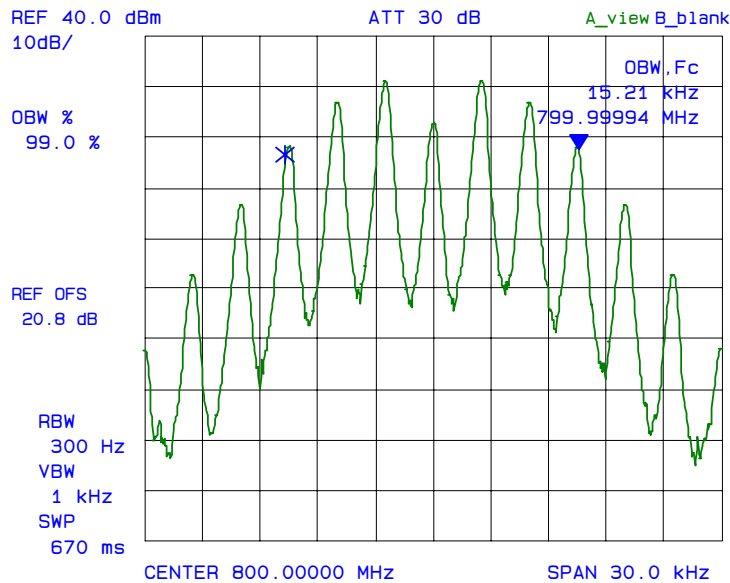

Plot 6.7.5.2.3.19: 99% Occupied Bandwidth (Input)
Fc: 800 MHz, Input Level: -15 dBm, Modulation: FM with an external 9600 bps random data source

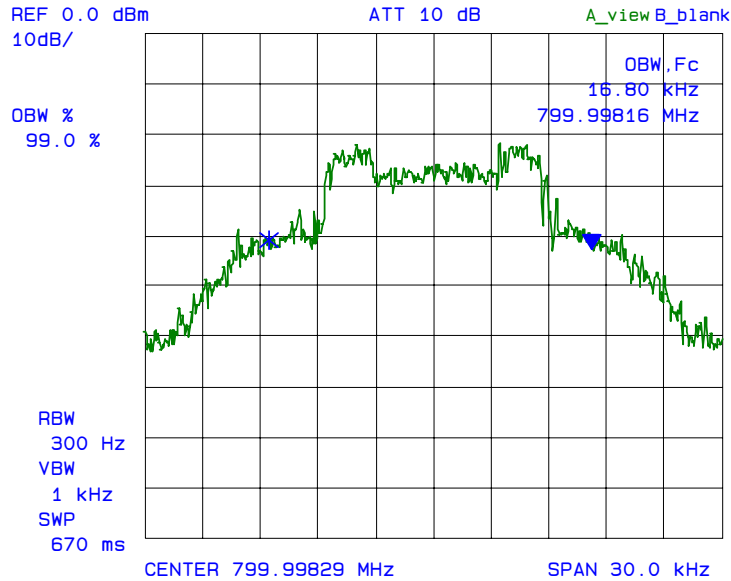

Plot 6.7.5.2.3.20: 99% Occupied Bandwidth (Output)
Fc: 800 MHz, Input Level: -15 dBm, Modulation: FM with an external 9600 bps random data source

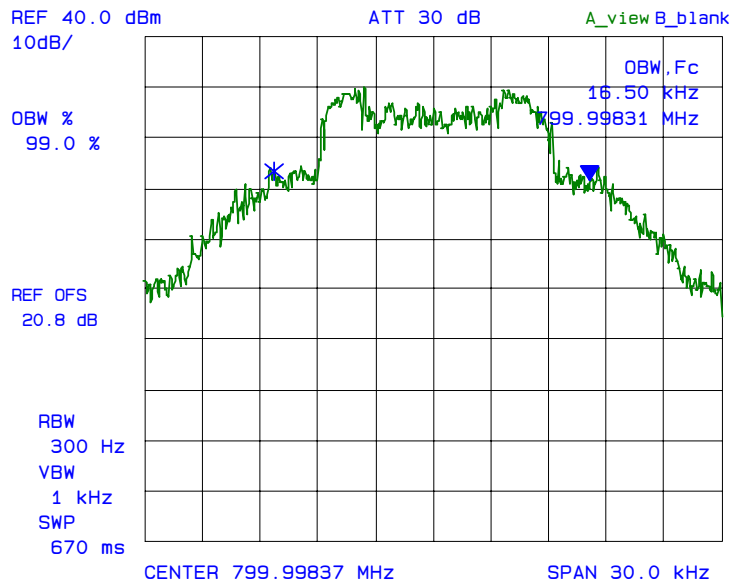

Plot 6.7.5.2.3.21: 99% Occupied Bandwidth (Input)
Fc: 806 MHz, Input Level: -15 dBm, Modulation: FM with 2.5 kHz sine wave signal

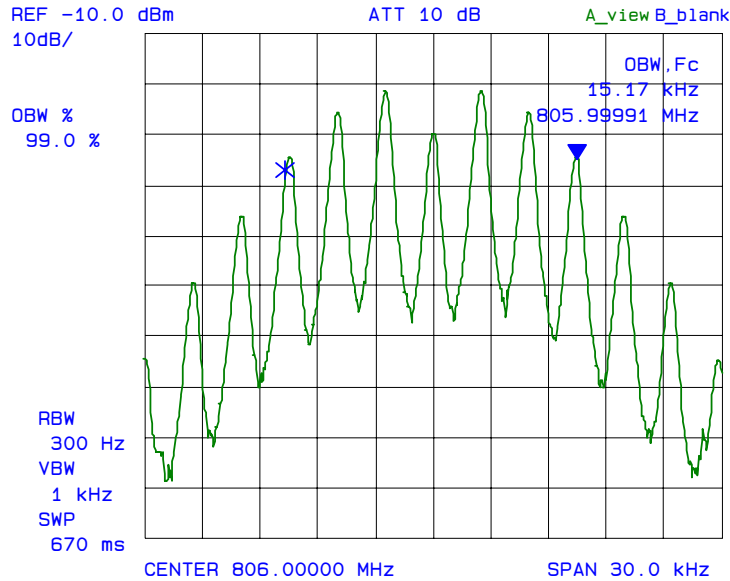

Plot 6.7.5.2.3.22: 99% Occupied Bandwidth (Output)
Fc: 806 MHz, Input Level: -15 dBm, Modulation: FM with 2.5 kHz sine wave signal

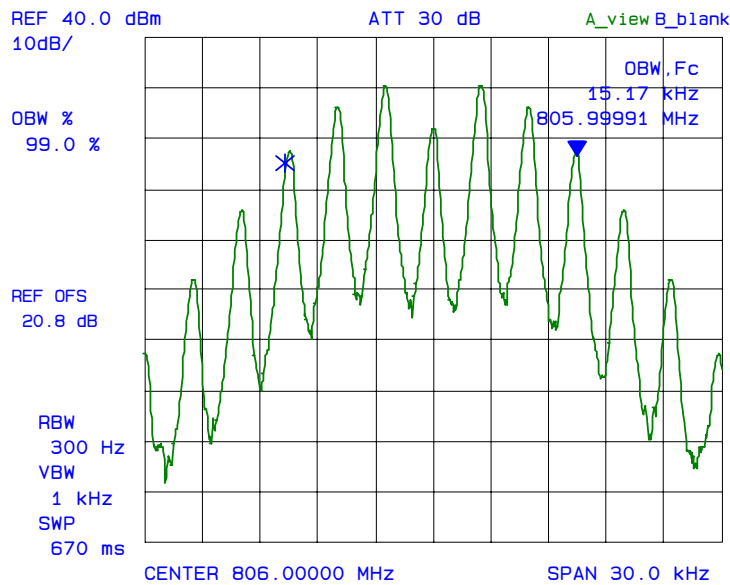

Plot 6.7.5.2.3.23: 99% Occupied Bandwidth (Input)
Fc: 806 MHz, Input Level: -15 dBm, Modulation: FM with an external 9600 bps random data source

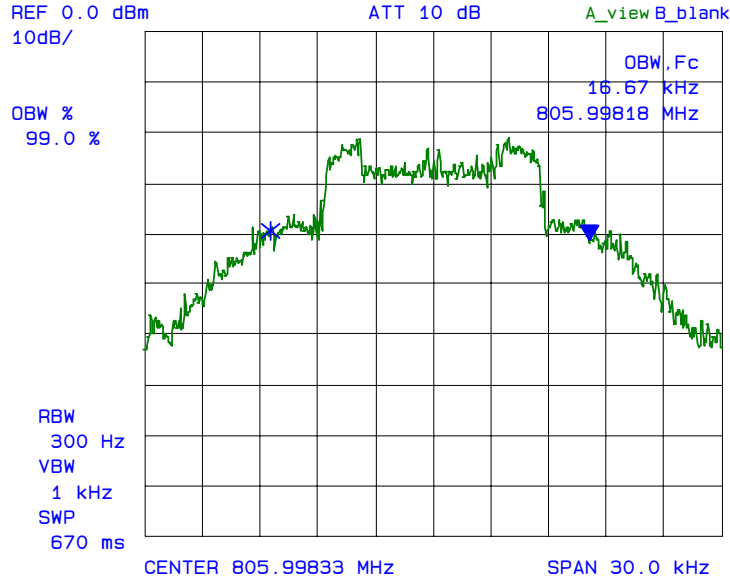

Plot 6.7.5.2.3.24: 99% Occupied Bandwidth (Output)
Fc: 806 MHz, Input Level: -15 dBm, Modulation: FM with an external 9600 bps random data source

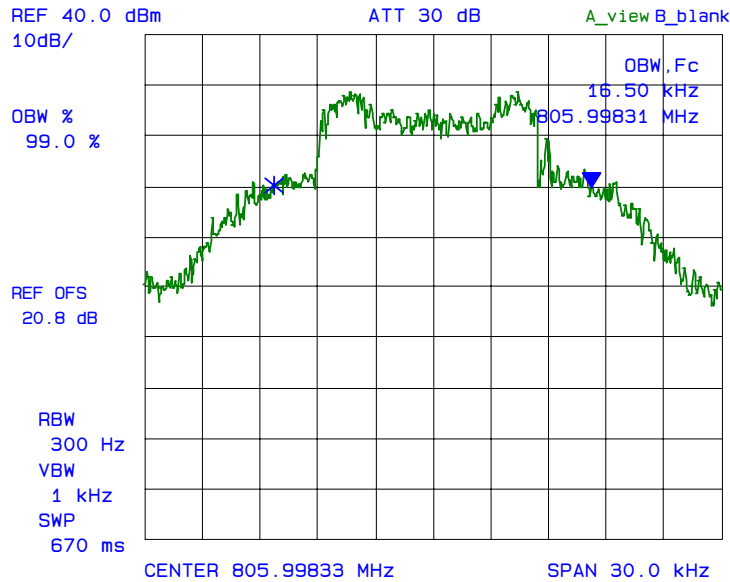

6.8. SPURIOUS EMISSIONS AT ANTENNA TERMINAL [§§ 2.1051 & 90.543(c)]

6.8.1. Limits

The power of any emission must be reduced below the unmodulated carrier power (P) by at least $43 + 10 \log (P)$ dB

6.8.2. Method of Measurements

Refer to ULTRATECH Test Procedures, File # ULTR P001-2004.

6.8.3. Test Equipment List

Test Instruments	Manufacturer	Model No.	Serial No.	Frequency Range
Spectrum Analyzer	Advantest	R3271	15050203	100Hz-26.5GHz
Attenuator	Weinschel Corp	46-20-34	BM1347	DC - 18 GHz
High Pass Filter	Microphase	5915-688-9088	MT1000AB	0.95 - 10 GHz
Signal Generator	Gigatronic	6061A	5130586	10 kHz - 1050 MHz
Signal Generator	Fluke	6061A	4770301	10 kHz - 1050 MHz
Signal Generator	Gigatronic	6061A	5130408	10 kHz - 1050 MHz
Combiner	Mini-Circuit	15542	0105	1 MHz – 1 GHz

6.8.4. Test Arrangement

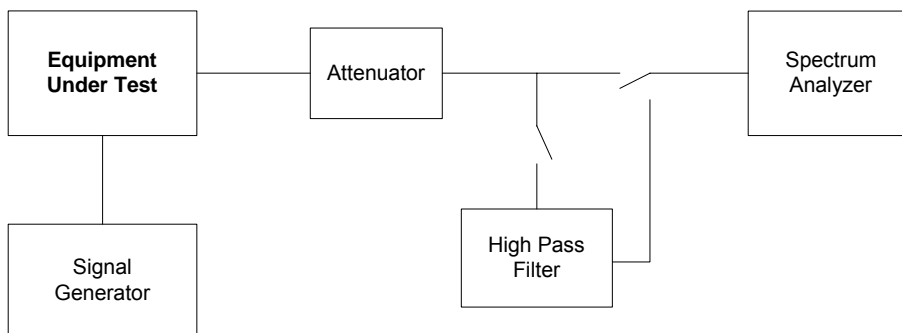

6.8.5. Test Data

Remarks:

- (1) There was no difference in spurious/harmonic emissions on pre-scans for all different modulations. Therefore, the rf spurious/harmonic emissions in this section would be performed without modulation and it shall represent for all different modulations required.
- (2) The emissions were scanned from 10 MHz to 8.5 GHz.

Fundamental Frequency: 764 MHz (1 RF Signal input/output)
RF Output Power: 35.75 dBm (conducted)
Modulation: Unmodulated

See the following plots for details:

Plot 6.8.5.1
Spurious Emissions at Antenna Terminal with 1 RF signal input/output
Fc: 764 MHz

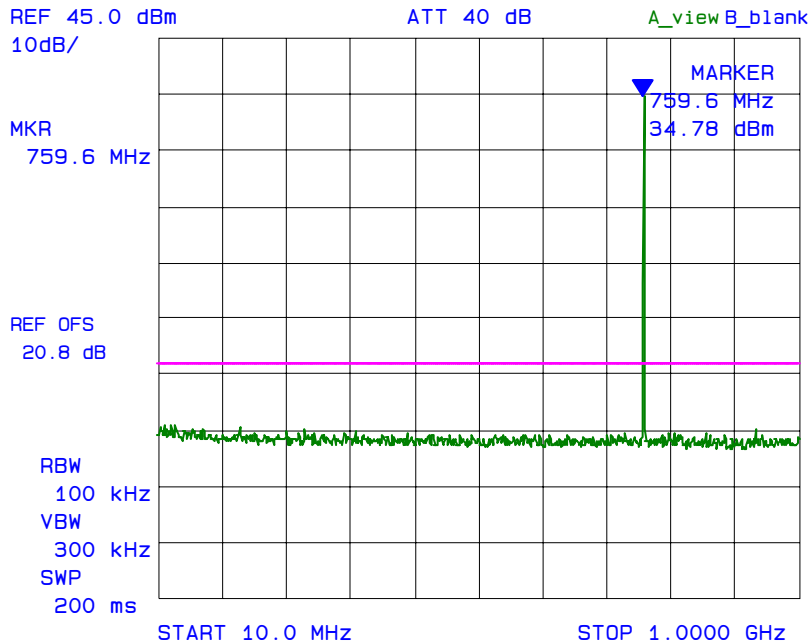

Plot 6.8.5.2
Spurious Emissions at Antenna Terminal with 1 RF signal input/output
Fc: 764 MHz

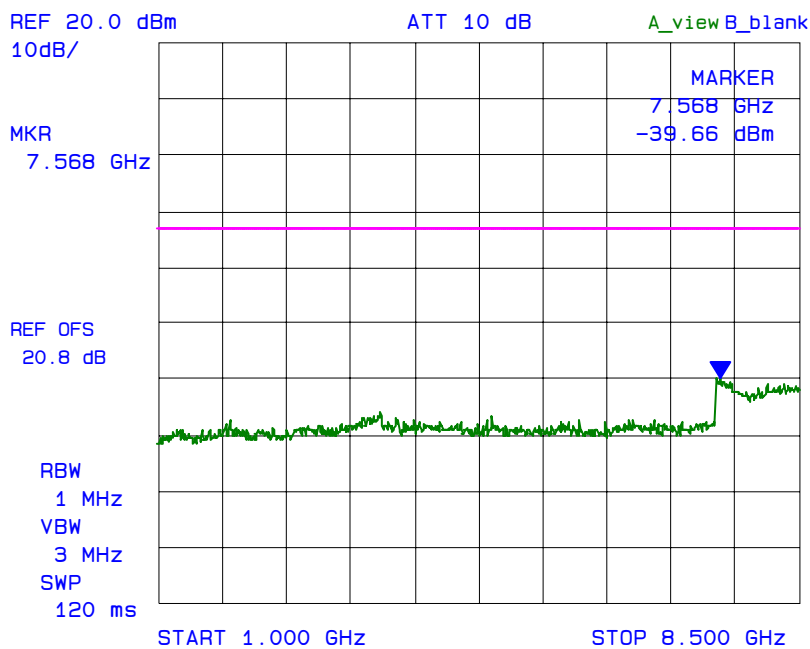

Fundamental Frequency: 764 MHz & 764.025 MHz (2 channel inputs/outputs)
RF Output Power: 31.75 dBm (conducted)
Modulation: Unmodulated

See the following plots for details:

Plot 6.8.5.3
Spurious Emissions at Antenna Terminal with 2 RF signal inputs/outputs
Fc: 764 MHz, Fc + 25 kHz

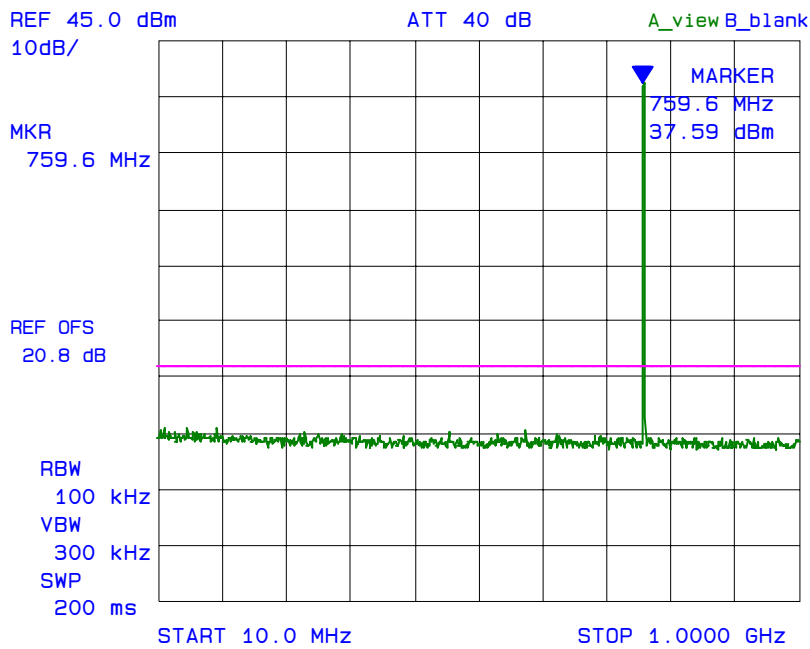

Plot 6.8.5.4
Spurious Emissions at Antenna Terminal with 2 RF signal inputs/outputs
Fc: 764 MHz, Fc + 25 kHz

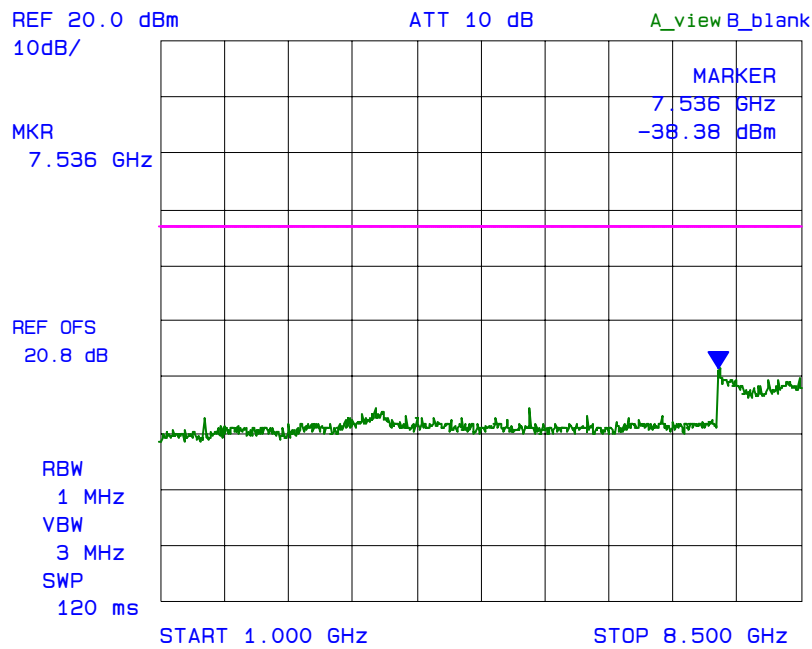

Fundamental Frequency: 764 MHz, 764.025 MHz & 764.050 MHz (3 channel inputs/outputs)
RF Output Power: 31.00 dBm (conducted)
Modulation: Unmodulated

See the following plots for details:

Plot 6.8.5.5
Spurious Emissions at Antenna Terminal with 3 RF signal inputs/outputs
Fc: 764 MHz, Fc + 25 kHz, Fc + 50 kHz

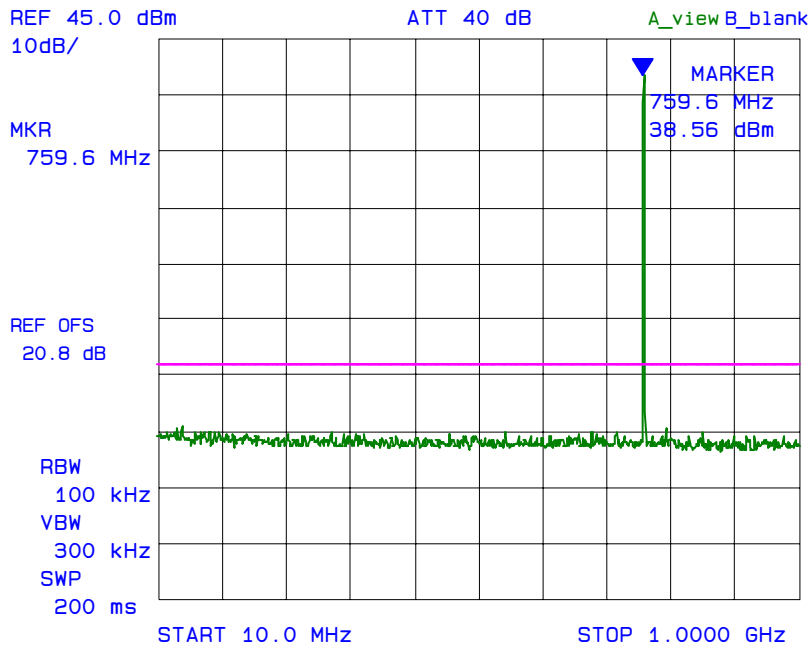

Plot 6.8.5.6
Spurious Emissions at Antenna Terminal with 3 RF signal inputs/outputs
Fc: 764 MHz, Fc + 25 kHz, Fc + 50 kHz

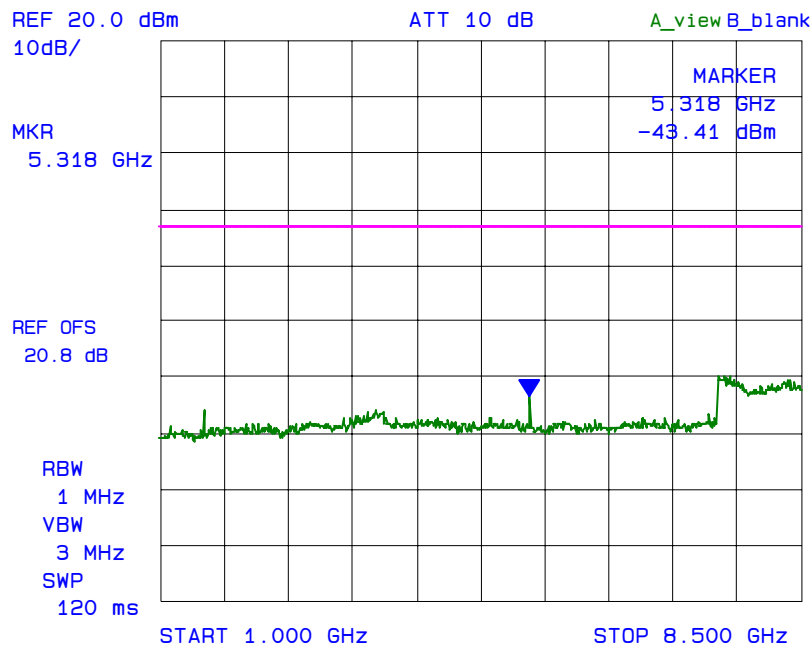

Fundamental Frequency: 770 MHz (1 RF Signal input/output)
RF Output Power: 35.31 dBm (conducted)
Modulation: Unmodulated

See the following plots for details:

Plot 6.8.5.7
Spurious Emissions at Antenna Terminal with 1 RF signal input/output
Fc: 770 MHz

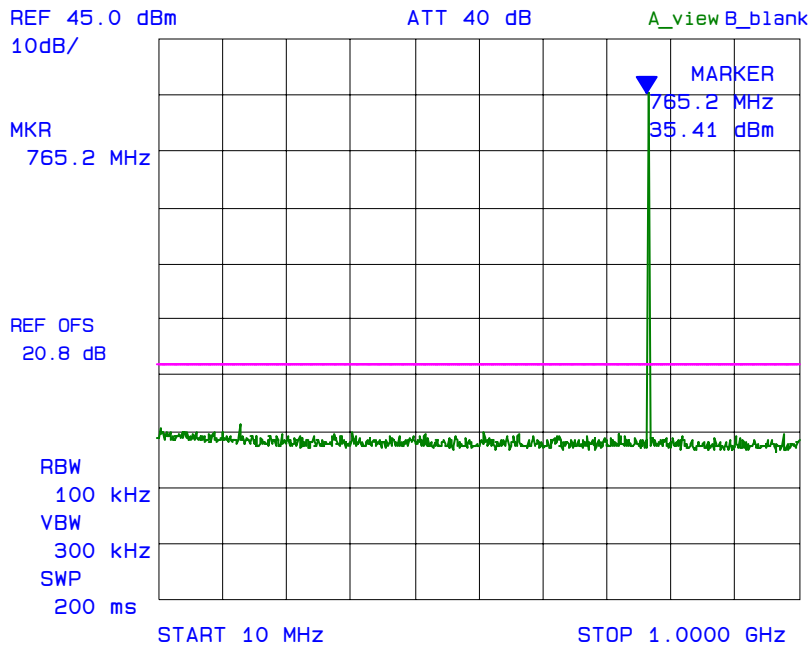

Plot 6.8.5.8
Spurious Emissions at Antenna Terminal with 1 RF signal input/output
Fc: 770 MHz

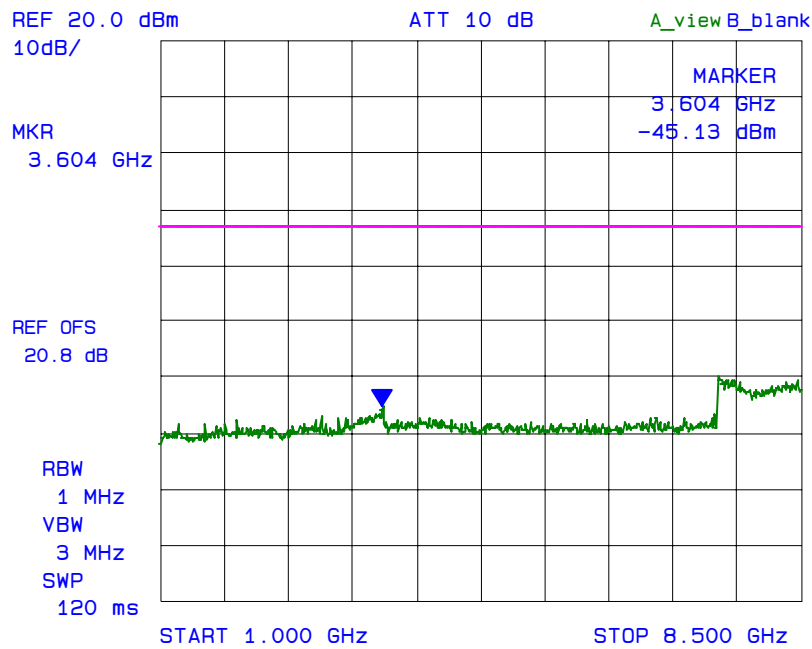

Fundamental Frequency: 770 MHz, 770.025 MHz (2 channel inputs/outputs)
RF Output Power: 32.19 dBm (conducted)
Modulation: Unmodulated

See the following plots for details:

Plot 6.8.5.9
Spurious Emissions at Antenna Terminal with 2 RF signal inputs/outputs
Fc: 770 MHz, Fc + 25 kHz

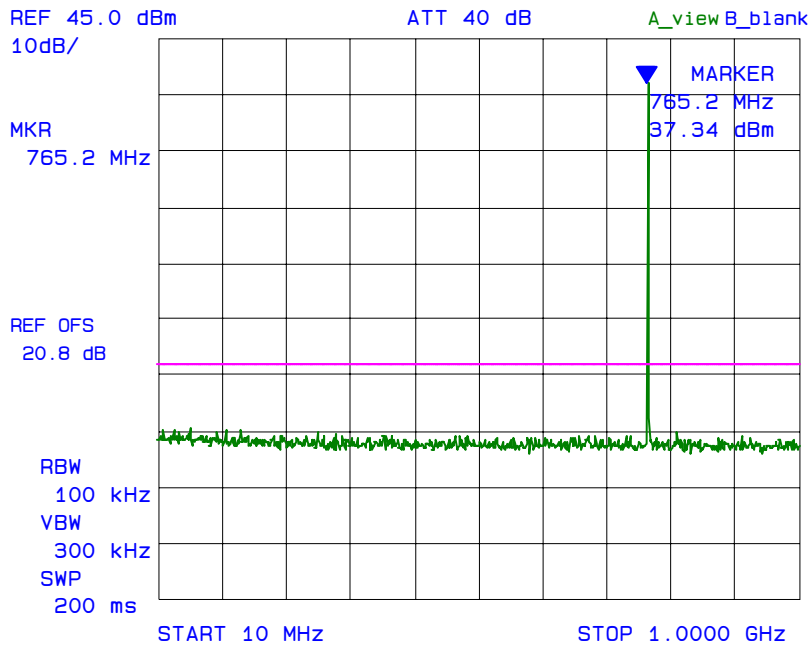

Plot 6.8.5.10
Spurious Emissions at Antenna Terminal with 2 RF signal inputs/outputs
Fc: 770 MHz, Fc + 25 kHz

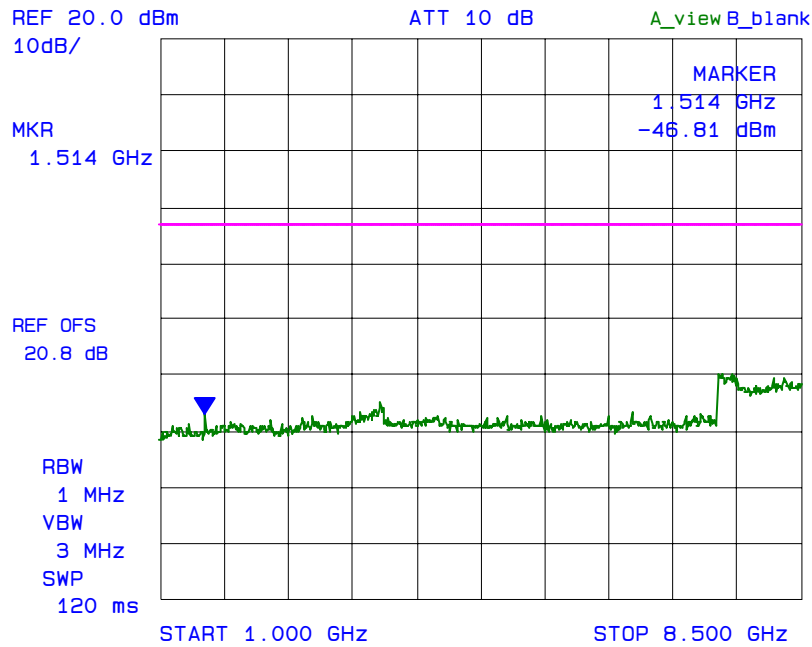

Fundamental Frequency: 770 MHz, 770.025, 770.050 MHz (3 channel inputs/outputs)
RF Output Power: 31.28 dBm (conducted)
Modulation: Unmodulated

See the following plots for details:

Plot 6.8.5.11
Spurious Emissions at Antenna Terminal with 3 RF signal inputs/outputs
Fc: 770 MHz, Fc + 25 kHz, Fc + 50 kHz

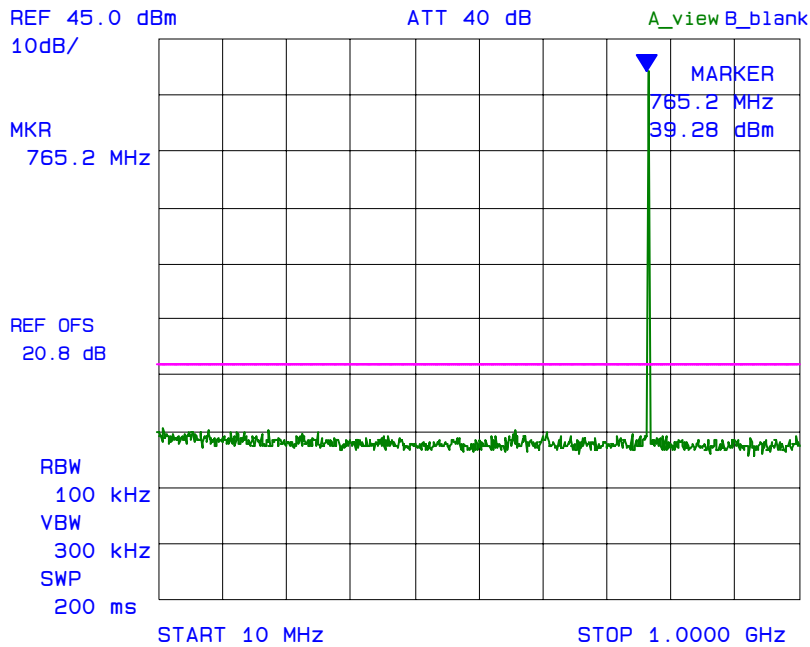

Plot 6.8.5.12
Spurious Emissions at Antenna Terminal with 3 RF signal inputs/outputs
Fc: 770 MHz, Fc + 25 kHz, Fc + 50 kHz

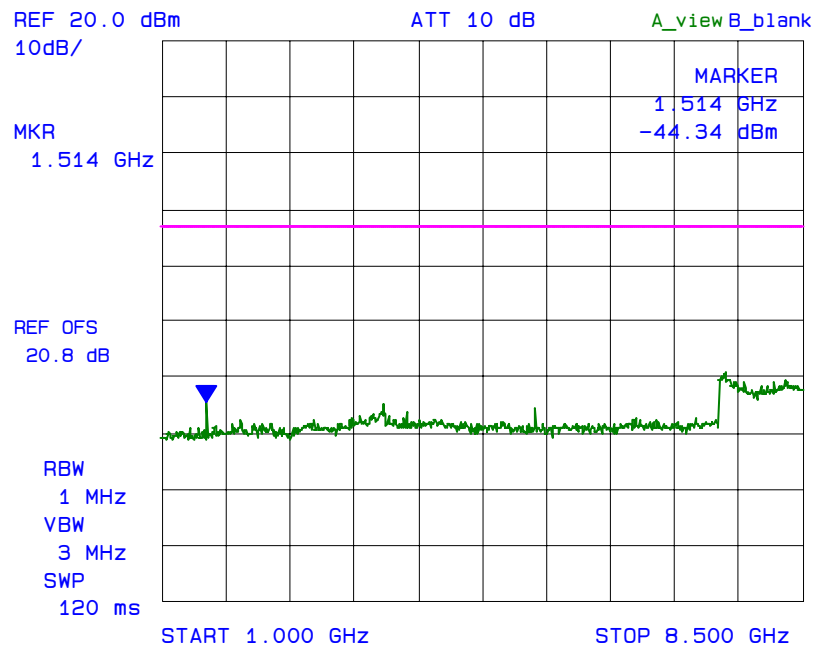

Fundamental Frequency: 776 MHz (1 RF Signal input/output)
RF Output Power: 34.72 dBm (conducted)
Modulation: Unmodulated

See the following plots for details:

Plot 6.8.5.13
Spurious Emissions at Antenna Terminal with 1 RF signal input/output
Fc: 776 MHz

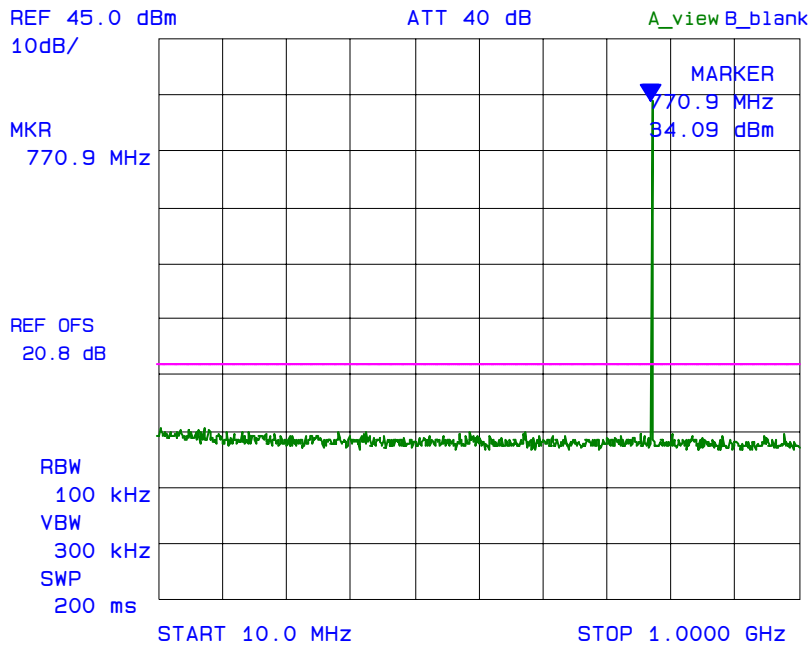

Plot 6.8.5.14
Spurious Emissions at Antenna Terminal with 1 RF signal input/output
Fc: 776 MHz

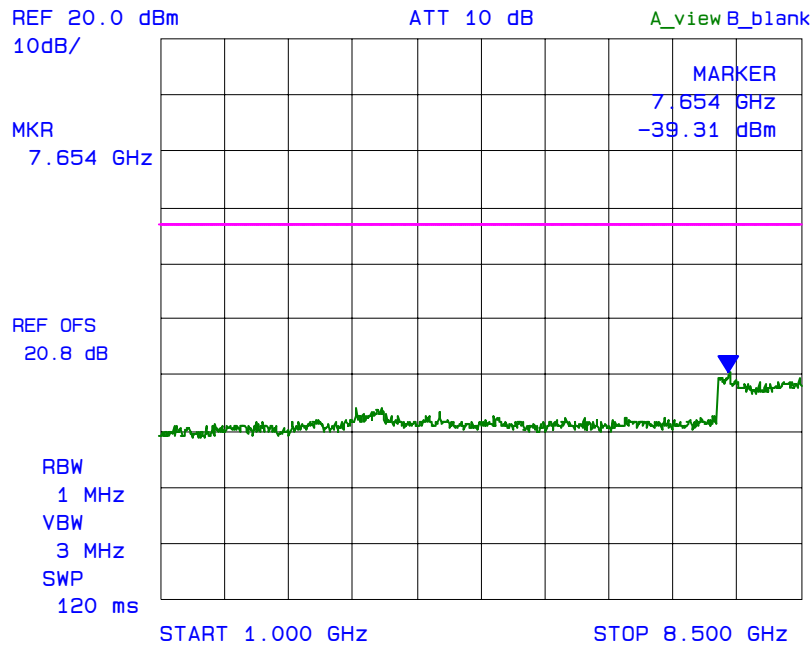

Fundamental Frequency: 776 MHz & 775.975 MHz, (2 channel inputs/outputs)
RF Output Power: 31.75 dBm (conducted)
Modulation: Unmodulated

See the following plots for details:

Plot 6.8.5.15
Spurious Emissions at Antenna Terminal with 2 RF signal inputs/outputs
Fc: 776 MHz, Fc - 25 kHz

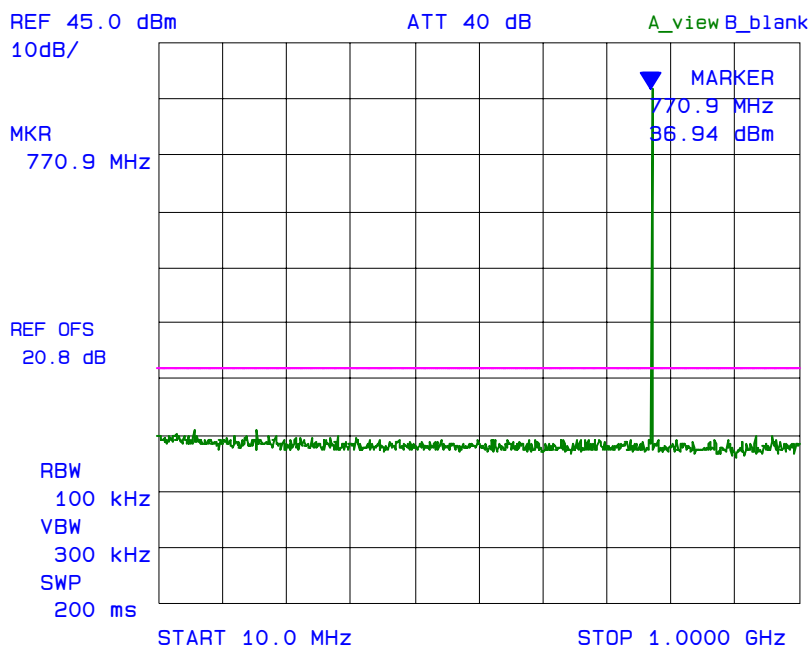

Plot 6.8.5.16
Spurious Emissions at Antenna Terminal with 2 RF signal inputs/outputs
Fc: 776 MHz, Fc - 25 kHz

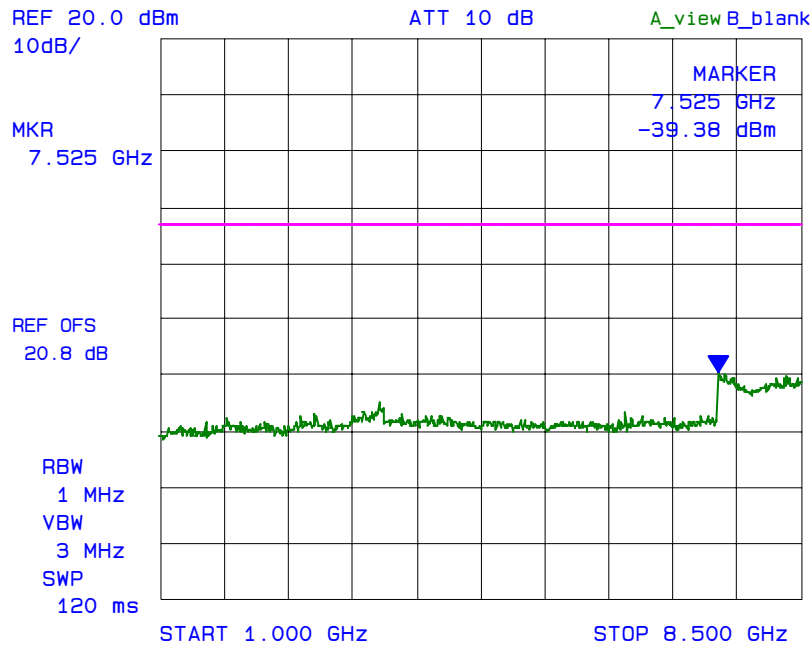

Fundamental Frequency: 776 MHz, 776.975 MHz & 776.950 MHz (3 channel inputs/outputs)
RF Output Power: 30.72 dBm (conducted)
Modulation: Unmodulated

See the following plots for details:

Plot 6.8.5.17
Spurious Emissions at Antenna Terminal with 3 RF signal inputs/outputs
Fc: 776 MHz, Fc - 25 kHz, Fc - 50 kHz

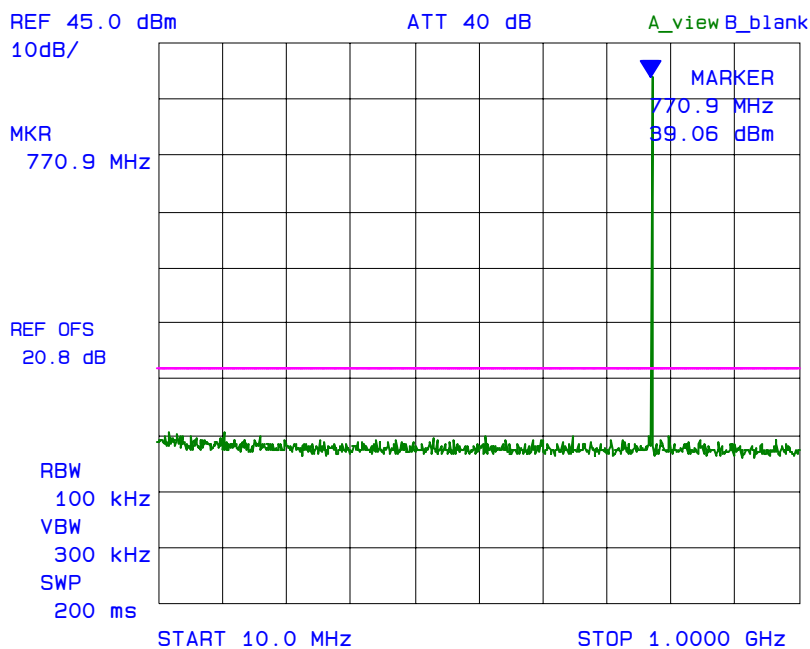

Plot 6.8.5.18
Spurious Emissions at Antenna Terminal with 3 RF signal inputs/outputs
Fc: 776 MHz, Fc - 25 kHz, Fc - 50 kHz

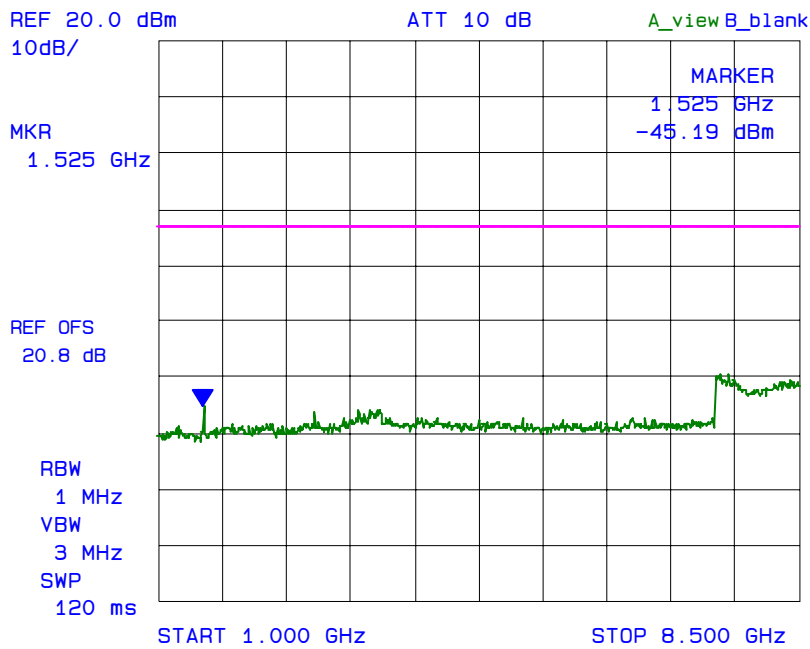

Fundamental Frequency: 794 MHz (1 RF Signal input/output)
RF Output Power: 35.06 dBm (conducted)
Modulation: Unmodulated

See the following plots for details:

Plot 6.8.5.19
Spurious Emissions at Antenna Terminal with 1 RF signal input/output
Fc: 794 MHz

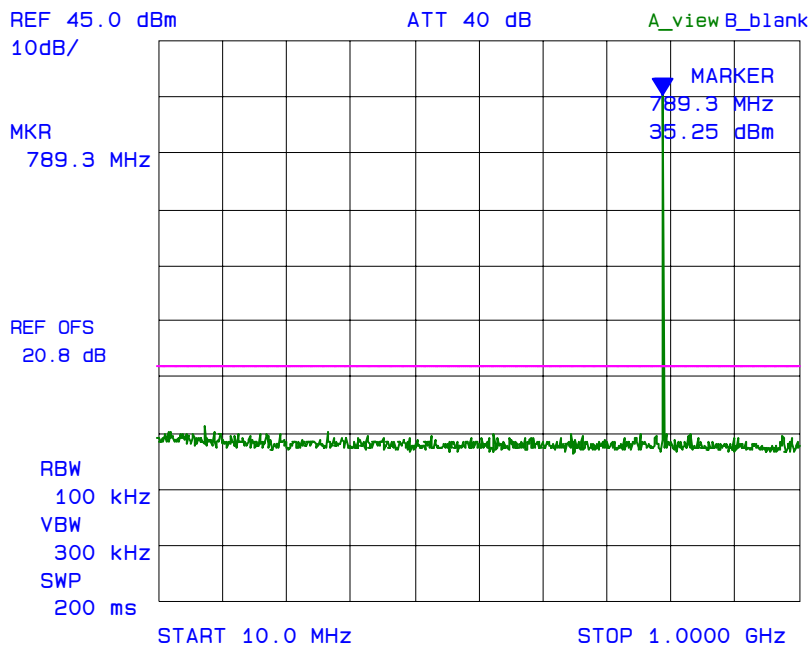

Plot 6.8.5.20
Spurious Emissions at Antenna Terminal with 1 RF signal input/output
Fc: 794 MHz

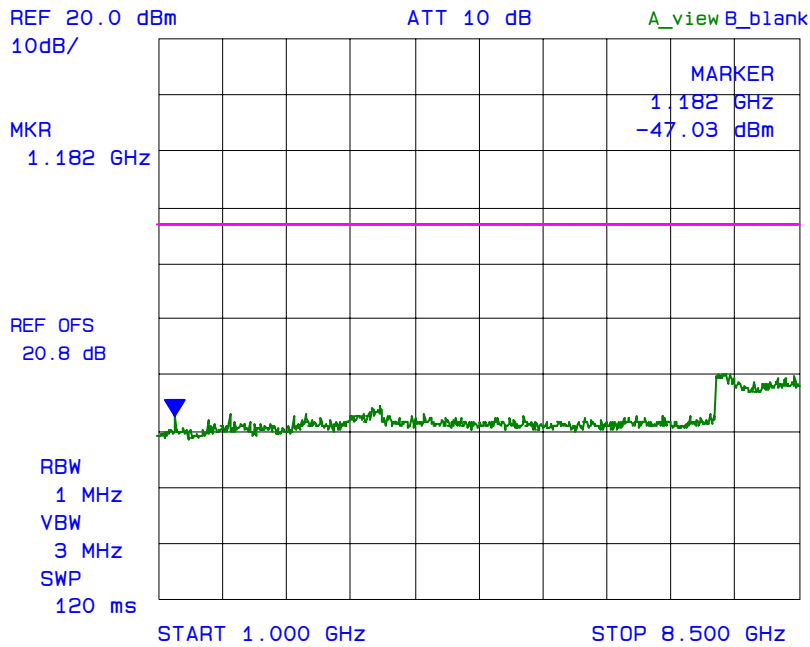

Fundamental Frequency: 794 MHz & 794.025 MHz (2 channel inputs/outputs)
RF Output Power: 31.72 dBm (conducted)
Modulation: Unmodulated

See the following plots for details:

Plot 6.8.5.21
Spurious Emissions at Antenna Terminal with 2 RF signal inputs/outputs
Fc: 794 MHz, Fc + 25 kHz

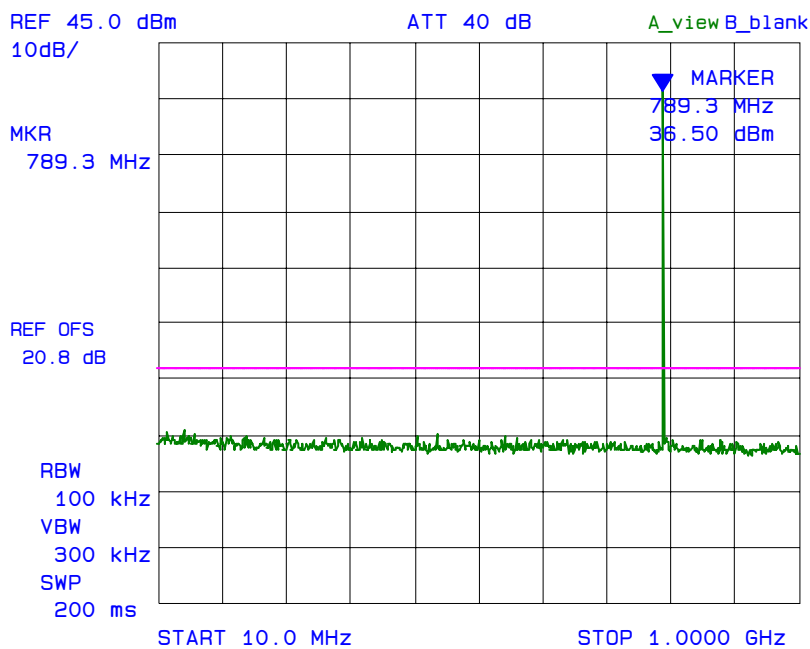

Plot 6.8.5.22
Spurious Emissions at Antenna Terminal with 2 RF signal inputs/outputs
Fc: 794 MHz, Fc + 25 kHz

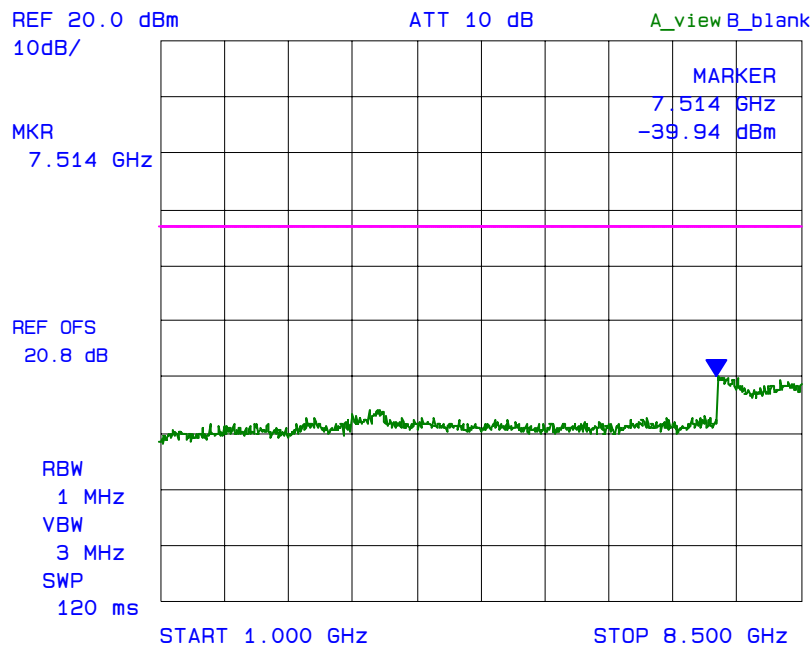

Fundamental Frequency: 794 MHz, 794.025 MHz 794.050 MHz (3 channel inputs/outputs)
RF Output Power: 30.75 dBm (conducted)
Modulation: Unmodulated

See the following plots for details:

Plot 6.8.5.23
Spurious Emissions at Antenna Terminal with 3 RF signal inputs/outputs
Fc: 794 MHz, Fc + 25 kHz, Fc + 50 kHz

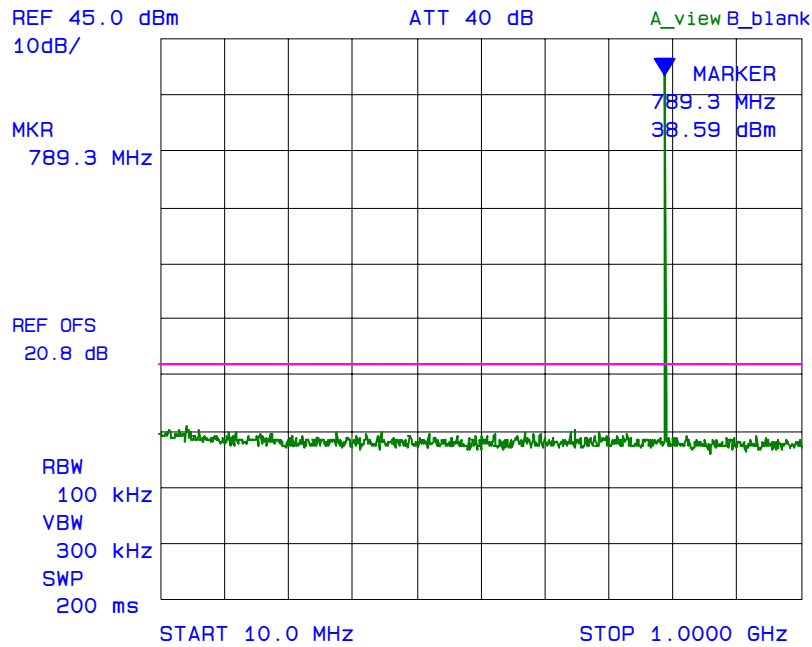

Plot 6.8.5.24
Spurious Emissions at Antenna Terminal with 3 RF signal inputs/outputs
Fc: 794 MHz, Fc + 25 kHz, Fc + 50 kHz

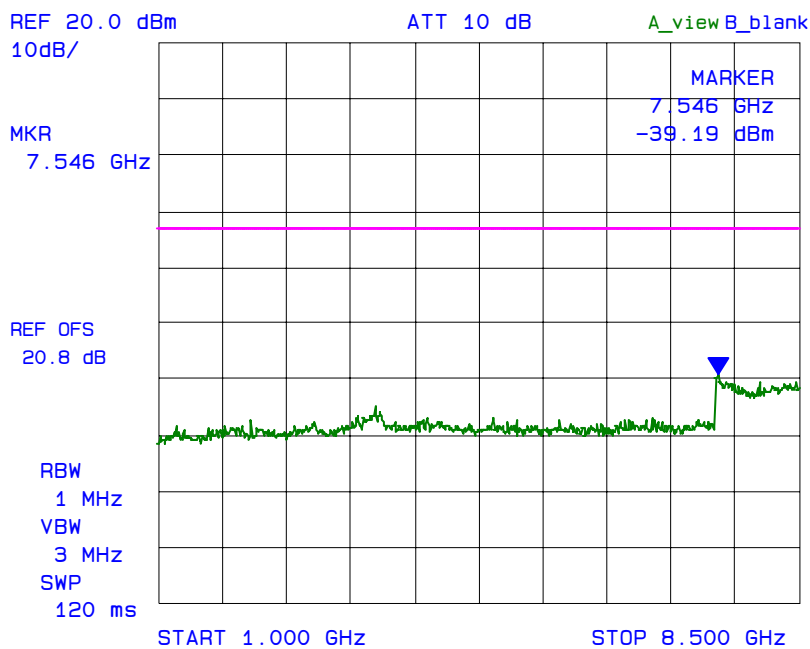

Fundamental Frequency: 800 MHz (1 RF Signal input/output)
RF Output Power: 35.97 dBm (conducted)
Modulation: Unmodulated

See the following plots for details:

Plot 6.8.5.25
Spurious Emissions at Antenna Terminal with 1 RF signal input/output
Fc: 800 MHz

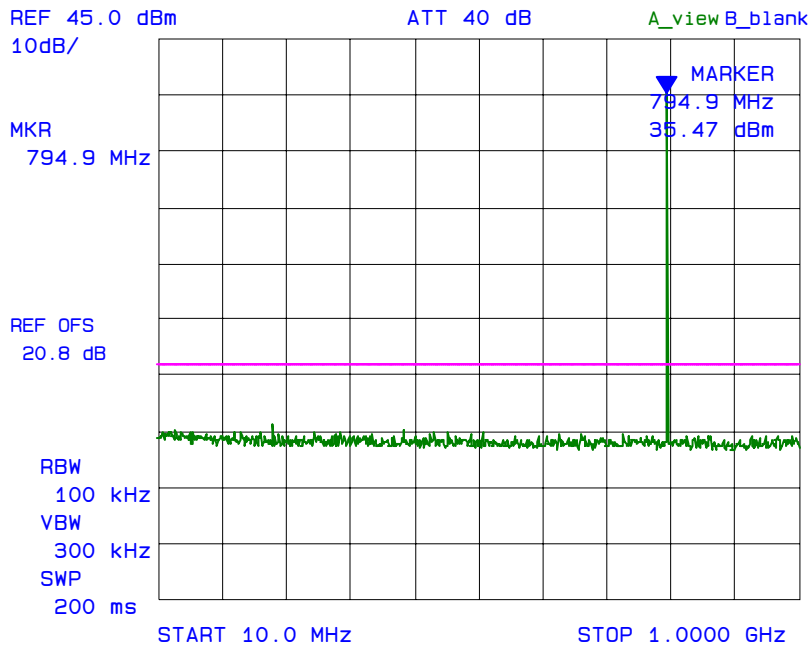

Plot 6.8.5.26
Spurious Emissions at Antenna Terminal with 1 RF signal input/output
Fc: 800 MHz

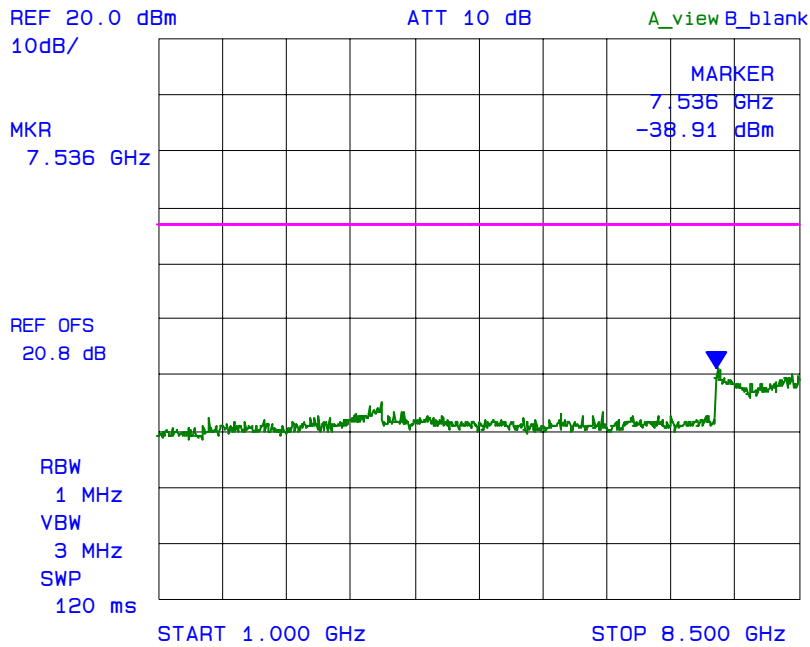

Fundamental Frequency: 800 MHz & 800.025 MHz (2 channel inputs/outputs)
RF Output Power: 32.06 dBm (conducted)
Modulation: Unmodulated

See the following plots for details:

Plot 6.8.5.27
Spurious Emissions at Antenna Terminal with 2 RF signal inputs/outputs
Fc: 800 MHz, Fc + 25 kHz

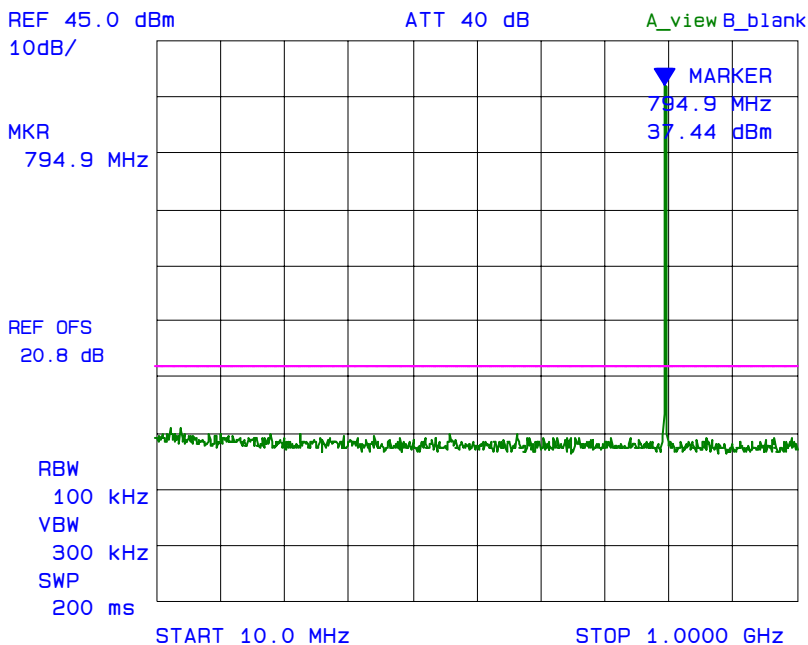

Plot 6.8.5.28
Spurious Emissions at Antenna Terminal with 2 RF signal inputs/outputs
Fc: 800 MHz, Fc + 25 kHz

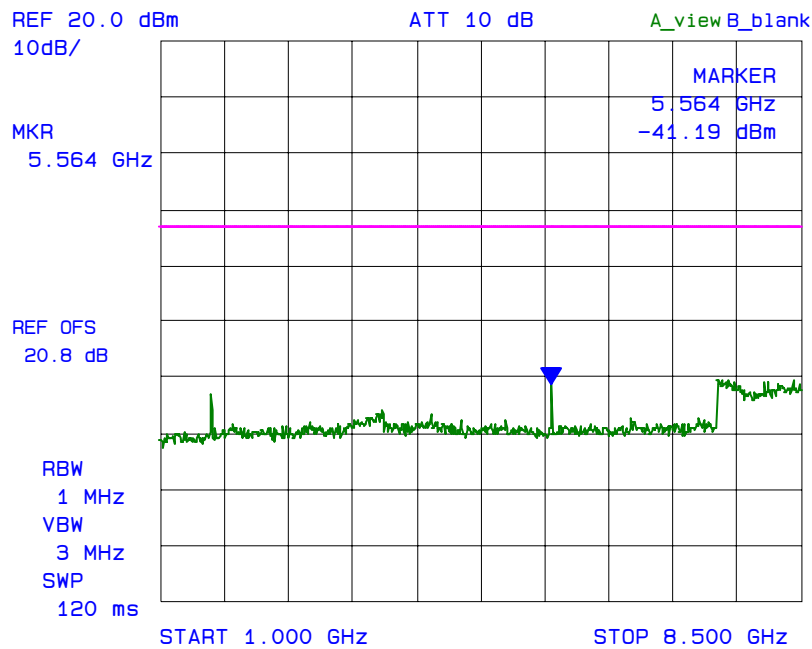

Fundamental Frequency: 800 MHz, 800.025 MHz & 800.050 MHz (3 channel inputs/outputs)
RF Output Power: 30.88 dBm (conducted)
Modulation: Unmodulated

See the following plots for details:

Plot 6.8.5.29
Spurious Emissions at Antenna Terminal with 3 RF signal inputs/outputs
Fc: 800 MHz, Fc + 25 kHz, Fc + 50 kHz

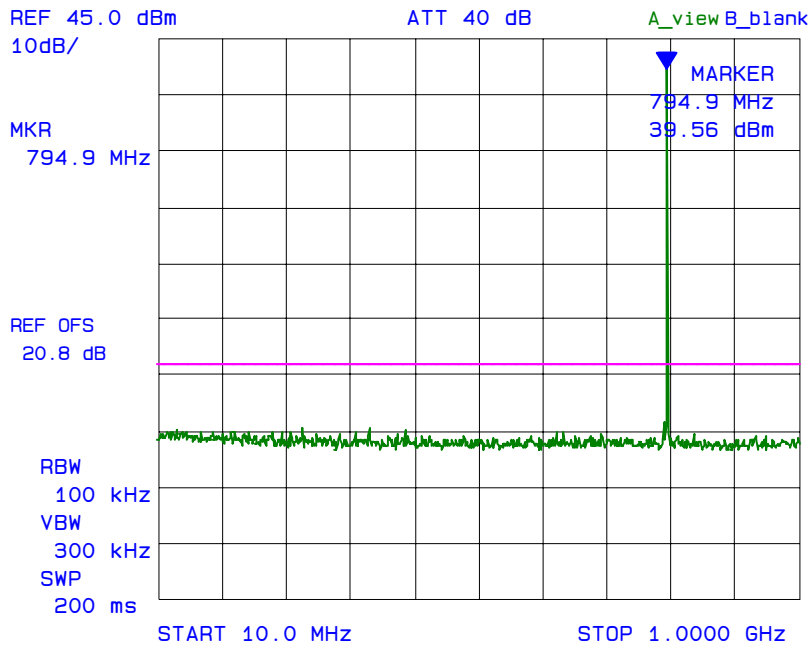

Plot 6.8.5.30
Spurious Emissions at Antenna Terminal with 3 RF signal inputs/outputs
Fc: 800 MHz, Fc + 25 kHz, Fc + 50 kHz

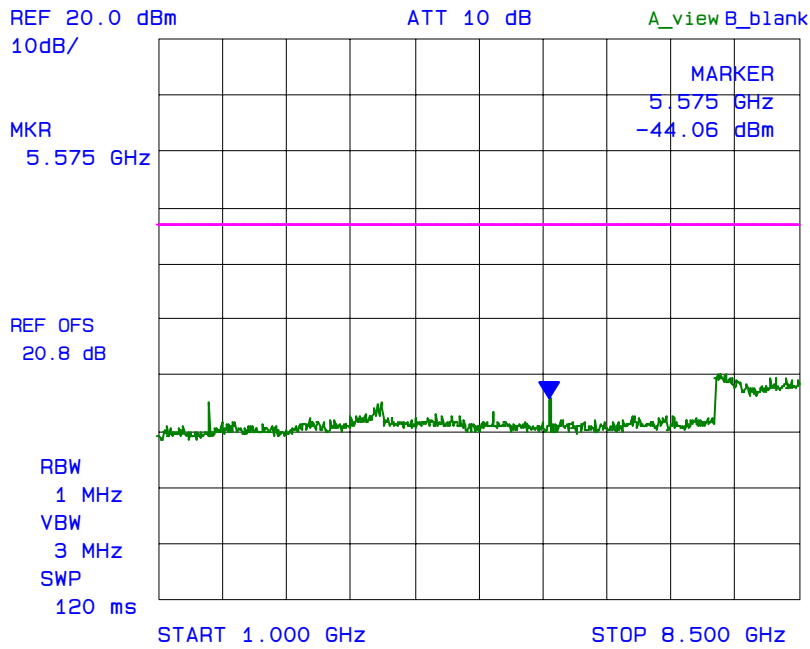

Fundamental Frequency: 806 MHz (1 RF Signal input/output)
RF Output Power: 35.41 dBm (conducted)
Modulation: Unmodulated

See the following plots for details:

Plot 6.8.5.31
Spurious Emissions at Antenna Terminal with 1 RF signal input/output
Fc: 806 MHz

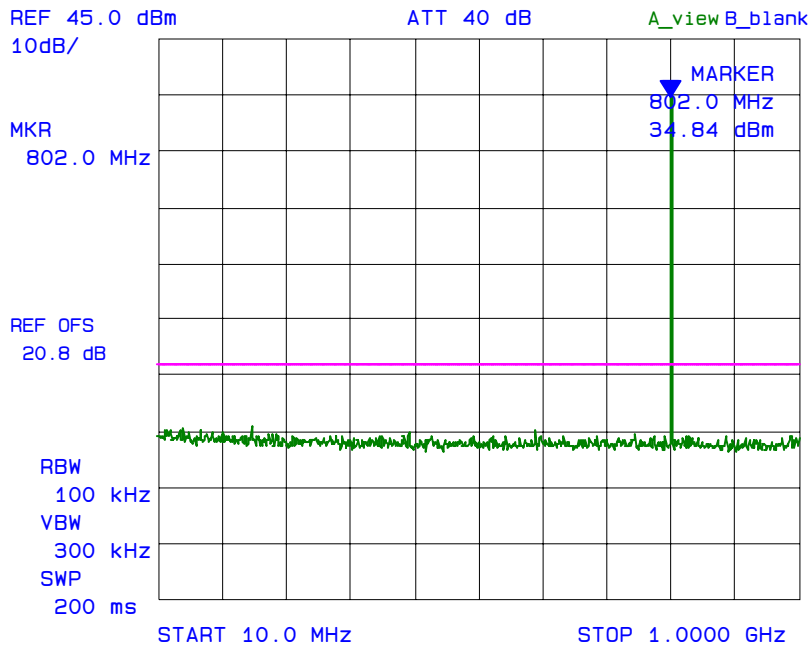

Plot 6.8.5.32
Spurious Emissions at Antenna Terminal with with 1 RF signal input/output
Fc: 806 MHz

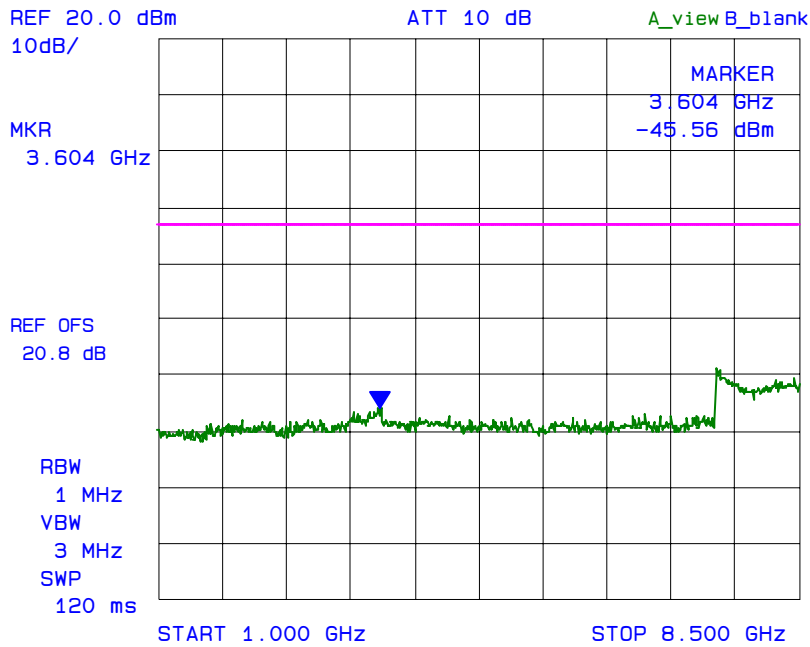

Fundamental Frequency: 806 MHz & 805.975 MHz, (2 channel inputs/outputs)
RF Output Power: 31.25 dBm (conducted)
Modulation: Unmodulated

See the following plots for details:

Plot 6.8.5.33
Spurious Emissions at Antenna Terminal with 2 RF signal inputs/outputs
Fc: 806 MHz, Fc - 25 kHz

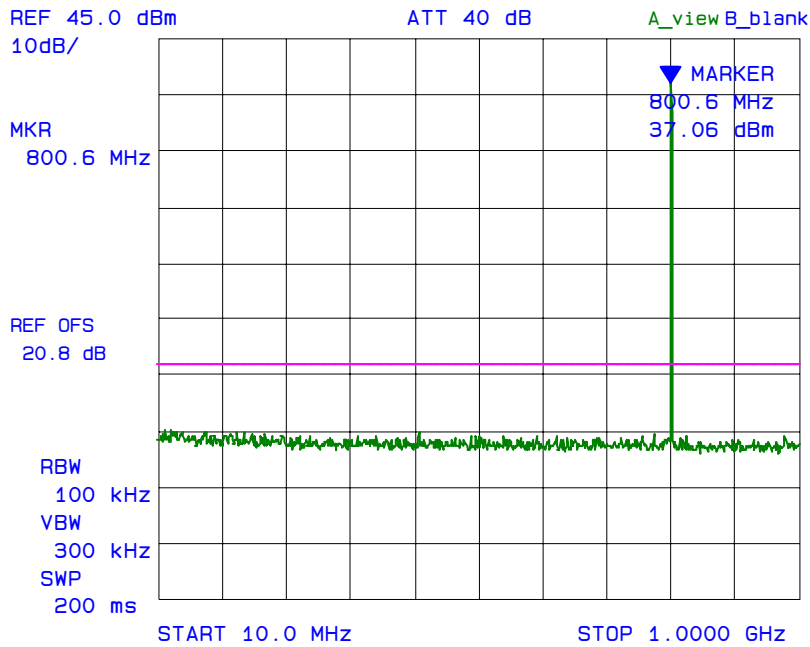

Plot 6.8.5.34
Spurious Emissions at Antenna Terminal with 2 RF signal inputs/outputs
Fc: 806 MHz, Fc - 25 kHz

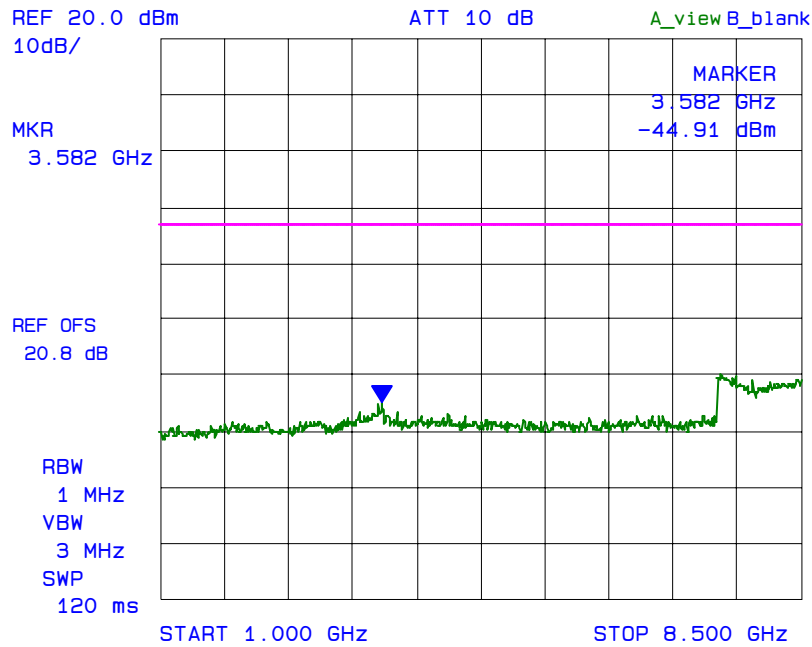

Fundamental Frequency: 806 MHz, 805.975 MHz & 805.950 MHz (3 channel inputs/outputs)
RF Output Power: 30.31 dBm (conducted)
Modulation: Unmodulated

See the following plots for details:

Plot 6.8.5.35
Spurious Emissions at Antenna Terminal with 3 RF signal inputs/outputs
Fc: 806 MHz, Fc - 25 kHz, Fc - 50 kHz

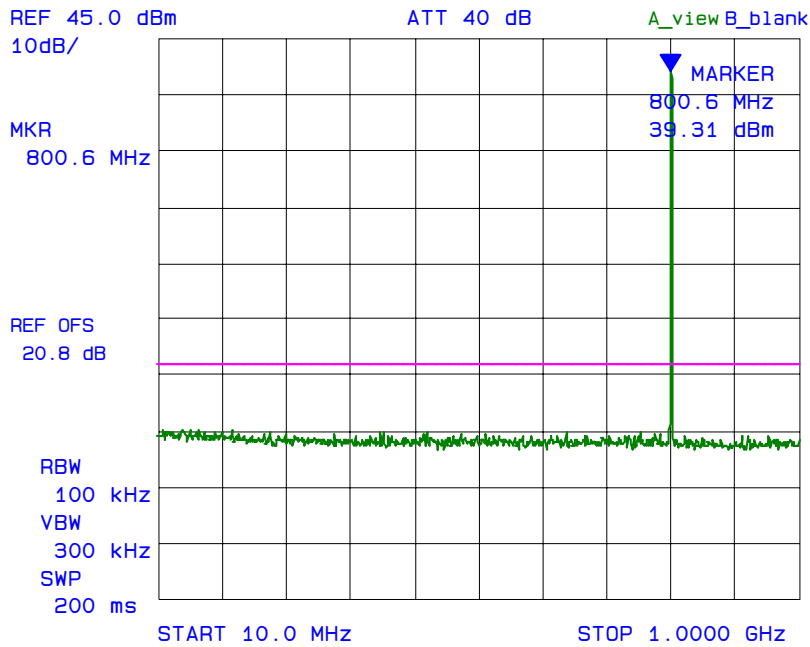

Plot 6.8.5.36
Spurious Emissions at Antenna Terminal with 3 RF signal inputs/outputs
Fc: 806 MHz, Fc - 25 kHz, Fc - 50 kHz

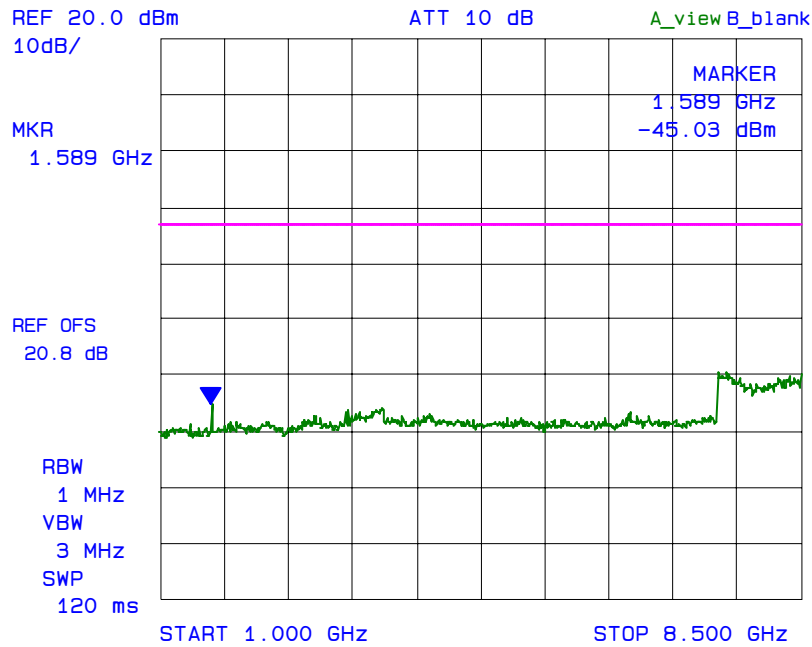

6.9. FIELD STRENGTH OF SPURIOUS EMISSIONS [§§ 2.1053 & 90.543(c)]

6.9.1. Limits

The power of any emission must be reduced below the unmodulated carrier power (P) by at least $43 + 10 \log (P)$ dB.

90.543(e) - For operations in the 764 to 776 MHz and 794 to 806 MHz bands, all emissions including harmonics in the band 1559-1610 MHz shall be limited to -70 dBW/MHz equivalent isotropically radiated power (EIRP) for wideband signals, and -80 dBW EIRP for discrete emissions of less than 700 Hz bandwidth. For the purpose of equipment authorization, a transmitter shall be tested with an antenna that is representative of the type that will be used with the equipment in normal operation.

6.9.2. Method of Measurements

The spurious/harmonic ERP measurements are using substitution method specified in Exhibit 8, Section 8.2 of this report and its value in dBc is calculated as follows:

- (1) If the transmitter's antenna is an integral part of the EUT, the ERP is measured using substitution method.
- (2) If the transmitter's antenna is non-integral and diverse, the lowest ERP of the carrier with 0 dBi antenna gain is used for calculation of the spurious/harmonic emissions in dBc:
 Lowest ERP of the carrier = $EIRP - 2.15 \text{ dB} = P_c + G - 2.15 \text{ dB} = P_c \text{ dBm (conducted)} + 0 \text{ dBi} - 2.15 \text{ dB}$
- (3) Spurious /harmonic emissions levels expressed in dBc (dB below carrier) are as follows:

$$\text{ERP of spurious/harmonic (dBc)} = \text{ERP of carrier (dBm)} - \text{ERP of spurious/harmonic emission (dBm)}$$

6.9.3. Test Equipment List

Test Instruments	Manufacturer	Model No.	Serial No.	Frequency Range
Spectrum Analyzer	Rohde & Schwarz	FSEK20/B4/B21	834157/005	9 kHz – 40 GHz
RF Amplifier	Com-Power	PA-102		1 MHz to 1 GHz, 30 dB gain nominal
Microwave Amplifier	Hewlett Packard	HP 83017A		1 GHz to 26.5 GHz, 30 dB nominal
Biconilog Antenna	EMCO	3142	10005	30 MHz to 2 GHz
Dipole Antenna	EMCO	3121C	8907-434	30 GHz – 1 GHz
Dipole Antenna	EMCO	3121C	8907-440	30 GHz – 1 GHz
Horn Antenna	EMCO	3155	9701-5061	1 GHz – 18 GHz
Horn Antenna	EMCO	3155	9911-5955	1 GHz – 18 GHz
RF Signal Generator	Hewlett Packard	HP 83752B	3610A00457	0.01 – 20 GHz

6.9.4. Test Data

Remarks:

- § 90.543(e) is not applicable for this device.
- Modulation used: CW signal at low, middle and high frequency of each frequency bands.
- The radiated emissions were performed at 3 meters distance. At its maximum power for worst case.
- The emissions were scanned from 30 MHz to 8.5 GHz; all emissions that are within 20 dB below the limit are recorded.

6.9.4.1. 764-776 MHz Band

6.9.4.1.1. Lowest Frequency (764 MHz)

Carrier Frequency (MHz): 764
 Power (dBm): 35.47
 Limit (dBc): -48.47

All emissions are more than 20 dB below the limit.

6.9.4.1.2. Middle Frequency (770 MHz)

Carrier Frequency (MHz): 770
 Power (dBm): 36.21
 Limit (dBc): -49.21

Frequency (MHz)	E-Field (dBµV/m)	EMI Detector (Peak/QP)	Antenna Polarization (H/V)	ERP measured by Substitution Method		Limit (dBc)	Margin (dB)
				(dBm)	(dBc)		
2310	73.28	Peak	V	-28.85	-65.1	-49.21	-15.9
2310	71.64	Peak	H	-31.17	-67.4	-49.21	-18.2

6.9.4.1.3. Highest Frequency (776 MHz)

Carrier Frequency (MHz): 776
 Power (dBm): 35.41
 Limit (dBc): -48.41

Frequency (MHz)	E-Field (dBµV/m)	EMI Detector (Peak/QP)	Antenna Polarization (H/V)	ERP measured by Substitution Method		Limit (dBc)	Margin (dB)
				(dBm)	(dBc)		
2328	75.08	Peak	V	-25.53	-60.9	-48.41	-12.5
2328	75.41	Peak	H	-26.98	-62.4	-48.41	-14.0

6.9.4.2. 794-806 MHz Band

6.9.4.2.1. Highest Frequency (794 MHz)

Carrier Frequency (MHz): 794
 Power (dBm): 36.21
 Limit (dBc): -49.21

Frequency (MHz)	E-Field (dBµV/m)	EMI Detector (Peak/QP)	Antenna Polarization (H/V)	ERP measured by Substitution Method		Limit (dBc)	Margin (dB)
				(dBm)	(dBc)		
2382	77.06	Peak	V	-24.07	-60.3	-49.21	-11.1
2382	77.41	Peak	H	-24.76	-61.0	-49.21	-11.8

6.9.4.2.2. Highest Frequency (800 MHz)

Carrier Frequency (MHz): 800
 Power (dBm): 36.19
 Limit (dBc): -49.19

Frequency (MHz)	E-Field (dBµV/m)	EMI Detector (Peak/QP)	Antenna Polarization (H/V)	ERP measured by Substitution Method		Limit (dBc)	Margin (dB)
				(dBm)	(dBc)		
2400	72.95	Peak	V	-27.85	-64.0	-49.19	-14.9
2400	70.97	Peak	H	-31.84	-68.0	-49.19	-18.8

6.9.4.2.3. Highest Frequency (806 MHz)

Carrier Frequency (MHz): 806
 Power (dBm): 36.31
 Limit (dBc): 49.31

Frequency (MHz)	E-Field (dBµV/m)	EMI Detector (Peak/QP)	Antenna Polarization (H/V)	ERP measured by Substitution Method		Limit (dBc)	Margin (dB)
				(dBm)	(dBc)		
1612	70.03	Peak	V	-30.98	67.3	49.31	-18.0
1612	70.82	Peak	H	-30.03	66.3	49.31	-17.0

EXHIBIT 7. MEASUREMENT UNCERTAINTY

The measurement uncertainties stated were calculated in accordance with the requirements of NIST Technical Note 1297 and NIS 81 (1994)

7.1. RADIATED EMISSION MEASUREMENT UNCERTAINTY

CONTRIBUTION (Radiated Emissions)	PROBABILITY DISTRIBUTION	UNCERTAINTY (\pm dB)	
		3 m	10 m
Antenna Factor Calibration	Normal (k=2)	± 1.0	± 1.0
Cable Loss Calibration	Normal (k=2)	± 0.3	± 0.5
EMI Receiver specification	Rectangular	± 1.5	± 1.5
Antenna Directivity	Rectangular	+0.5	+0.5
Antenna factor variation with height	Rectangular	± 2.0	± 0.5
Antenna phase center variation	Rectangular	0.0	± 0.2
Antenna factor frequency interpolation	Rectangular	± 0.25	± 0.25
Measurement distance variation	Rectangular	± 0.6	± 0.4
Site imperfections	Rectangular	± 2.0	± 2.0
Mismatch: Receiver VRC $\Gamma_1 = 0.2$ Antenna VRC $\Gamma_R = 0.67$ (Bi) 0.3 (Lp) Uncertainty limits $20\text{Log}(1 \pm \Gamma_1 \Gamma_R)$	U-Shaped	+1.1 -1.25	± 0.5
System repeatability	Std. Deviation	± 0.5	± 0.5
Repeatability of EUT		-	-
Combined standard uncertainty	Normal	+2.19 / -2.21	+1.74 / -1.72
Expanded uncertainty U	Normal (k=2)	+4.38 / -4.42	+3.48 / -3.44

Calculation for maximum uncertainty when 3m biconical antenna including a factor of k = 2 is used:

$$U = 2u_c(y) = 2x(+2.19) = +4.38 \text{ dB} \quad \text{And} \quad U = 2u_c(y) = 2x(-2.21) = -4.42 \text{ dB}$$

EXHIBIT 8. MEASUREMENT METHODS

8.1. CONDUCTED POWER MEASUREMENTS

- The following shall be applied to the combination(s) of the radio device and its intended antenna(e).
- If the RF level is user adjustable; all measurements shall be made with the highest power level available to the user for that combination.
- The following method of measurement shall apply to both conducted and radiated measurements.
- The radiated measurements are performed at the Ultratech Calibrated Open Field Test Site.
- The measurement shall be performed using normal operation of the equipment with modulation.

Test procedure shall be as follows:

Step 1: Duty Cycle measurements if the transmitter's transmission is transient

- Using a EMI Receiver with the frequency span set to 0 Hz and the sweep time set at a suitable value to capture the envelope peaks and the duty cycle of the transmitter output signal;
- The duty cycle of the transmitter, $x = T_x \text{ on} / (T_x \text{ on} + T_x \text{ off})$ with $0 < x < 1$, is measure and recorded in the test report. For the purpose of testing, the equipment shall be operated with a duty cycle that is equal or more than 0.1.

Step 2: Calculation of Average EIRP. See Figure 1

- The average output power of the transmitter shall be determined using a wideband, calibrated RF average power meter with the power sensor with an integration period that exceeds the repetition period of the transmitter by a factor 5 or more. The observed value shall be recorded as "A" (in dBm);
- The e.i.r.p. shall be calculated from the above measured power output "A", the observed duty cycle x, and the applicable antenna assembly gain "G" in dBi, according to the formula:

$$\text{EIRP} = \text{A} + \text{G} + 10\log(1/x)$$

{ X = 1 for continuous transmission => $10\log(1/x) = 0 \text{ dB}$ }

Figure 1.

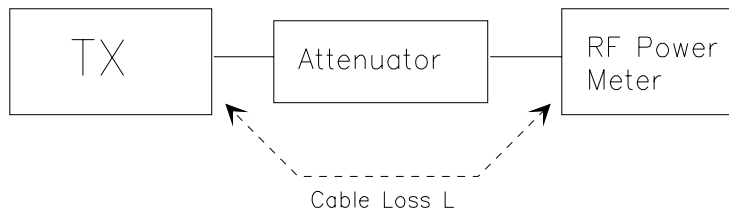

8.2. RADIATED POWER MEASUREMENTS (ERP & EIRP) USING SUBSTITUTION METHOD

8.2.1. Maximizing RF Emission Level (E-Field)

- (a) The measurements was performed with full rf output power and modulation.
- (b) Test was performed at listed 3m open area test site (listed with FCC, IC, ITI, NVLAP, ACA & VCCI).
- (c) The transmitter under test was placed at the specified height on a non-conducting turntable (80 cm height)
- (d) The BICONILOG antenna (20 MHz to 1 GHz) or HORN antenna (1 GHz to 18 GHz) was used for measuring.
- (e) Load an appropriate correction factors file in EMI Receiver for correcting the field strength reading level

Total Correction Factor recorded in the EMI Receiver = Cable Loss + Antenna Factor
 $E \text{ (dBuV/m)} = \text{Reading (dBuV)} + \text{Total Correction Factor (dB/m)}$

- (f) Set the EMI Receiver and #2 as follows:

Center Frequency: test frequency
Resolution BW: 100 kHz
Video BW: same
Detector Mode: positive
Average: off
Span: 3 x the signal bandwidth

- (g) The test antenna was lowered or raised from 1 to 4 meters until the maximum signal level was detected.
- (h) The transmitter was rotated through 360° about a vertical axis until a higher maximum signal was received.
- (i) The test antenna was lowered or raised again from 1 to 4 meters until a maximum was obtained. This level was recorded.
- (j) The recorded reading was corrected to the true field strength level by adding the antenna factor, cable loss and subtracting the pre-amplifier gain.
- (k) The above steps were repeated with both transmitters' antenna and test receiving antenna placed in vertical and horizontal polarization. Both readings with the antennas placed in vertical and horizontal polarization shall be recorded.
- (l) Repeat for all different test signal frequencies

8.2.2. Measuring the EIRP of Spurious/Harmonic Emissions using Substitution Method

(a) Set the EMI Receiver (for measuring E-Field) and Receiver #2 (for measuring EIRP) as follows:

Center Frequency: equal to the signal source
Resolution BW: 10 kHz
Video BW: same
Detector Mode: positive
Average: off
Span: 3 x the signal bandwidth

(b) Load an appropriate correction factors file in EMI Receiver for correcting the field strength reading level

Total Correction Factor recorded in the EMI Receiver = Cable Loss + Antenna Factor
 $E \text{ (dBuV/m)} = \text{Reading (dBuV)} + \text{Total Correction Factor (dB/m)}$

(c) Select the frequency and E-field levels obtained in the Section 8.2.1 for ERP/EIRP measurements.

(d) Substitute the EUT by a signal generator and one of the following transmitting antenna (substitution antenna):

- ◆ DIPOLE antenna for frequency from 30-1000 MHz or
- ◆ HORN antenna for frequency above 1 GHz }

(e) Mount the transmitting antenna at 1.5 meter high from the ground plane.

(f) Use one of the following antenna as a receiving antenna:

- ◆ DIPOLE antenna for frequency from 30-1000 MHz or
- ◆ HORN antenna for frequency above 1 GHz }

(g) If the DIPOLE antenna is used, tune it's elements to the frequency as specified in the calibration manual.

(h) Adjust both transmitting and receiving antenna in a VERTICAL polarization.

(i) Tune the EMI Receivers to the test frequency.

(j) Lower or raise the test antenna from 1 to 4 meters until the maximum signal level was detected.

(k) The transmitter was rotated through 360° about a vertical axis until a higher maximum signal was received.

(l) Lower or raise the test antenna from 1 to 4 meters until the maximum signal level was detected.

(m) Adjust input signal to the substitution antenna until an equal or a known related level to that detected from the transmitter was obtained in the test receiver.

(n) Record the power level read from the Average Power Meter and calculate the ERP/EIRP as follows:

$$P = P1 - L1 = (P2 + L2) - L1 = P3 + A + L2 - L1$$

$$EIRP = P + G1 = P3 + L2 - L1 + A + G1$$

$$ERP = EIRP - 2.15 \text{ dB}$$

$$\text{Total Correction factor in EMI Receiver \# 2} = L2 - L1 + G1$$

Where: P: Actual RF Power fed into the substitution antenna port after corrected.

P1: Power output from the signal generator

P2: Power measured at attenuator A input

P3: Power reading on the Average Power Meter

EIRP: EIRP after correction

ERP: ERP after correction

(o) Adjust both transmitting and receiving antenna in a HORIZONTAL polarization, then repeat step (k) to (o)

(p) Repeat step (d) to (o) for different test frequency

(q) Repeat steps (c) to (j) with the substitution antenna oriented in horizontal polarization.

(r) Actual gain of the EUT's antenna is the difference of the measured EIRP and measured RF power at the RF port. Correct the antenna gain if necessary.

Figure 2

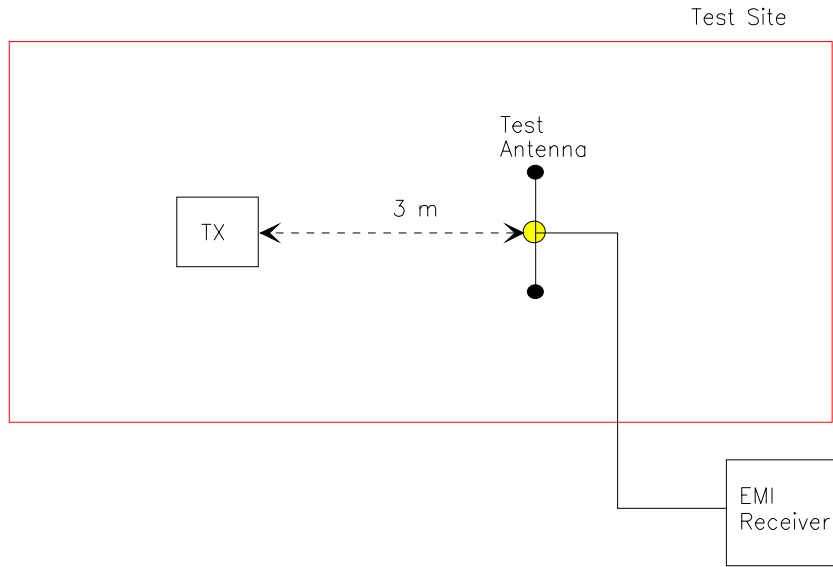

Figure 3

