

PRODUCTION

POIDS APPROXIMATIF (g) / APPROXIMATE WEIGHT (g) | 450

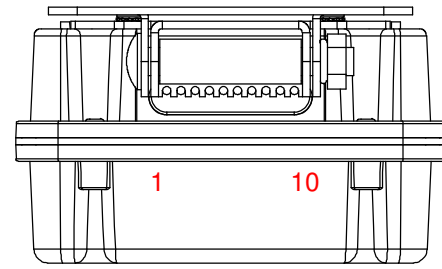

ARTICLE / ITEM	MATERIEL / MATERIAL
TOP HOUSING	PC, BLACK, TEXTURED OUTSIDE / POLISHED POCKET
BOTTOM HOUSING	PC, BLACK, TEXTURED
NOSE CONE	PC, BLACK, POLISHED
HOUSING GASKET	SILICONE RUBBER, BLACK
WIRE GROMMET	SILICONE RUBBER, BLACK
PAIRING BUTTON	SILICONE RUBBER, TRANSLUCENT

CLEARANCE HOLE FOR M5 (#10) SCREW (X2)

WIRE HARNESS (NOT SHOWN TO ACTUAL LENGTH)

M6 CARRIAGE BOLT/NUT FOR ANGLE ADJUSTMENT

CLEARANCE HOLE FOR M6 (1/4") BOLT

HARNESS COLOR CODE				
POSITION	FUNCTION	GAUGE	WIRE COLOUR	LENGTH (m)
1	VBAT 12V	20	RED	2
2	GROUND	20	BLACK	2
3	HOOD INPUT (-)	20	GRAY	2
4	TACH INPUT (+)	20	VIOLET / WHITE	2
5	AUX INPUT (-)	20	BLUE	1.5
6	AUX OUT 1 (+)	20	PINK	1.5
7	AUX OUT 2 (-)	20	ORANGE	1.5
8	AUX INPUT (+)	20	YELLOW	1.5
9	LED (+)	20	RED / WHITE	2
10	LED (-)	20	BLACK / WHITE	2

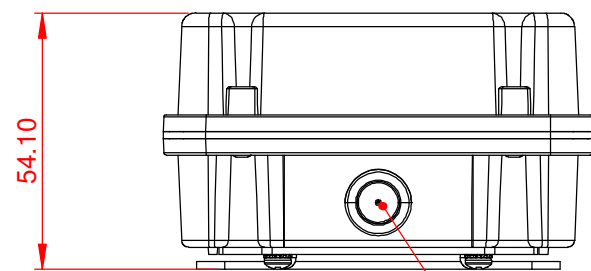
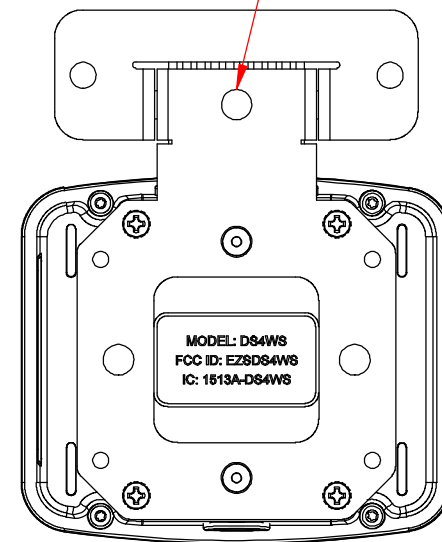
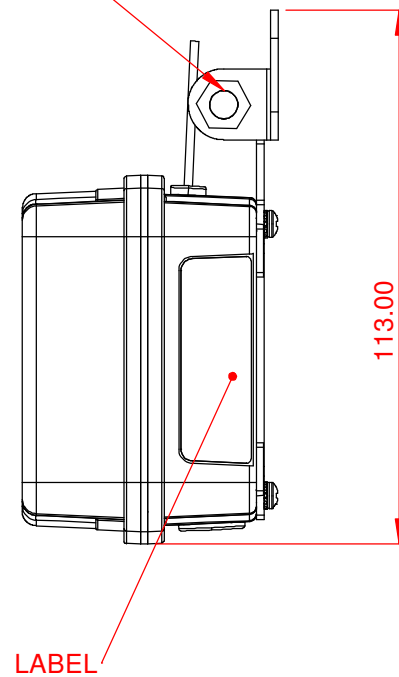
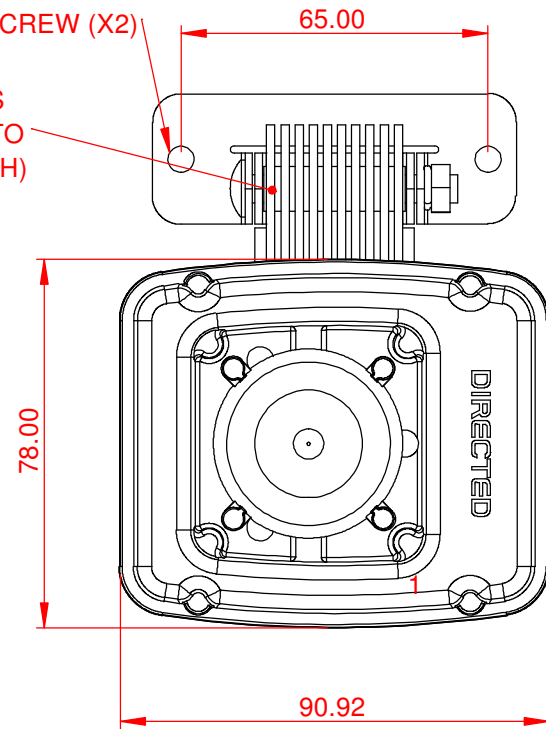

PAIRING BUTTON (ILLUMINATED)

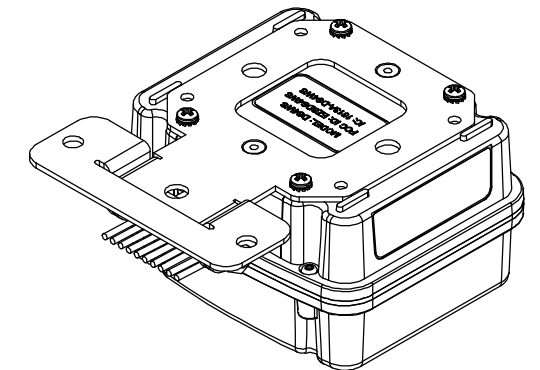
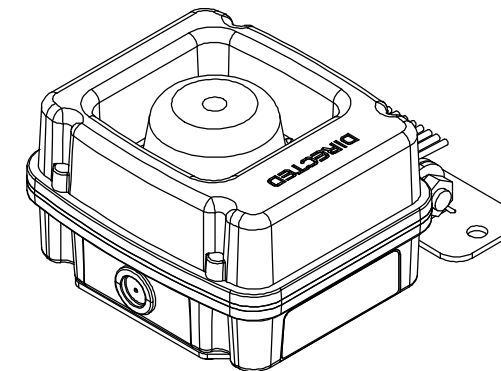

ECO	REV	DESCRIPTION	PAR / BY
2304	R1.6	RELEASE FOR TOOLING	A.T.
2304	R1.5	RELEASE CANDIDATE FOR TOOLING	A.T.

DESSINE DRAWN	APPROUVE APPROVED
---------------	-------------------

TOLERANCES

SAUF INDICATION CONTRAIRE UNLESS OTHERWISE NOTED

X mm	+/- 1 mm
X.X mm	+/- 0.5 mm
X.XX mm	+/- 0.10 mm

DIRECTED
VIPER | CLIFFORD | PYTHON | AUTOMATE | AVITAL | AstroStart | AUTOSTART

DIMENSIONS EN mm CREE / CREATED
 DIMENSIONS IN mm 2018-01-12

PRODUIT PRODUCT	DS4WS		
ARTICLE ARTICLE	LAYOUT		
DESSIN / DRAWING	REV	PAGE	
LDG-127-10013-01	R1.6	1 / 2	

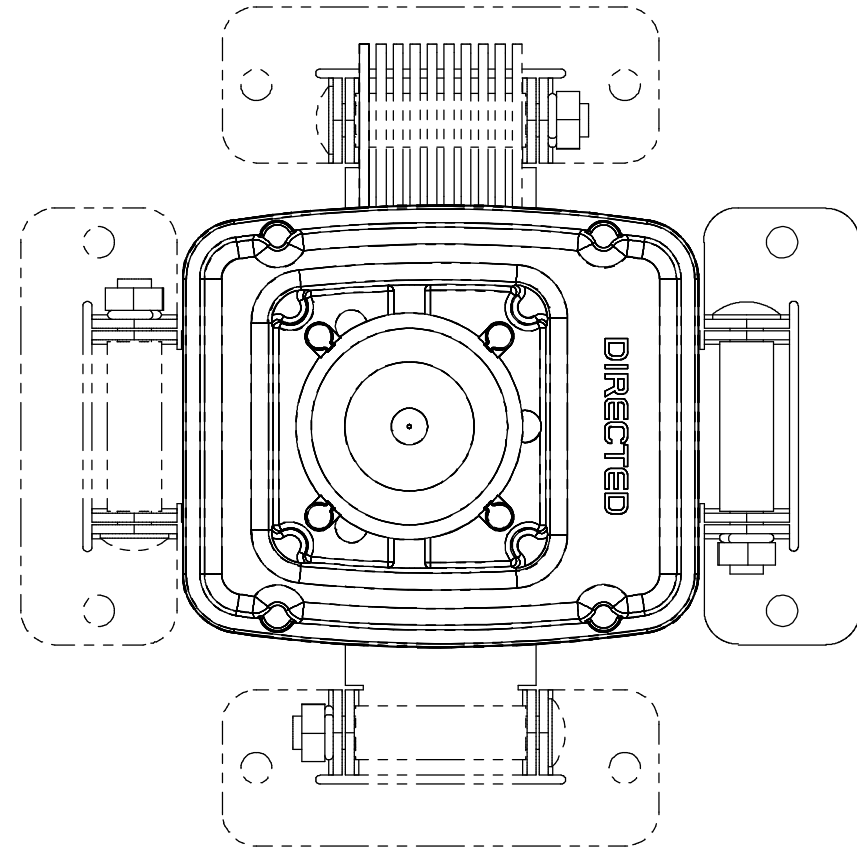

MOUNTING PLATE/BRACKET POSITIONING OPTIONS

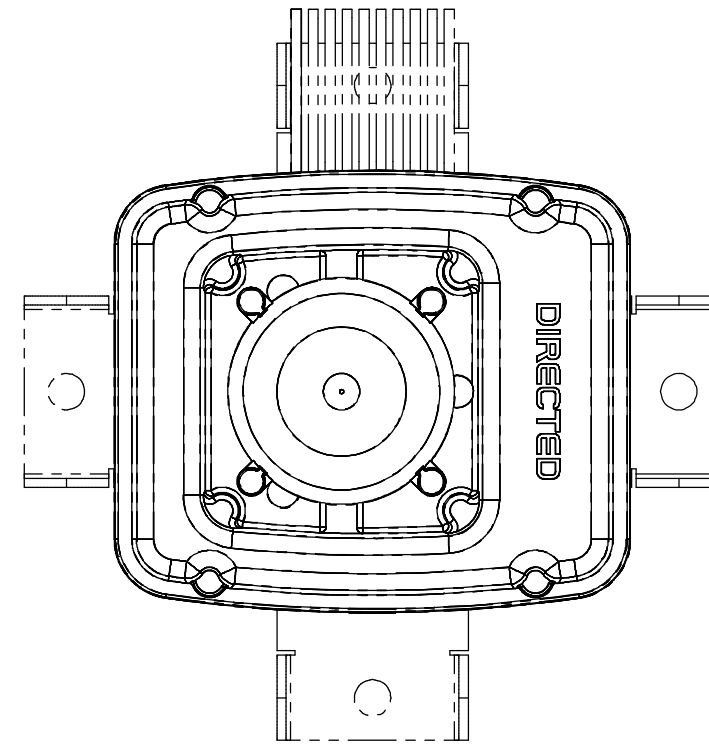

MOUNTING PLATE POSITIONING OPTIONS

DESSINE DRAWN	APPROUVE APPROVED
------------------	----------------------

TOLERANCES	
SAUF INDICATION CONTRAIRE UNLESS OTHERWISE NOTED	
X mm	+/- 1 mm
X.X mm	+/- 0.5 mm
X.XX mm	+/- 0.10 mm

DIRECTED [®]	
VIPER CLIFFORD PANTON AUTOMATE AVITAL AstroStart AUTOSTART	
DIMENSIONS EN mm	CREE / CREATED
DIMENSIONS IN mm	2018-01-12

PRODUIT PRODUCT	DS4WS		
ARTICLE ARTICLE	LAYOUT		
DESSIN / DRAWING	REV	PAGE	
LDG-127-10013-01	R1.6	2 / 2	