

REVISIONS				
REV.	ACC.	DESCRIPTION	DRN.	DATE
△	5/7 MAIL	MODIFY ICONS	YYS	5/7/'13
△				

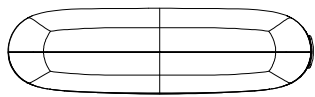

TOP/BOTTOM HOUSING:
BLACK

LENS COLOR:BLACK

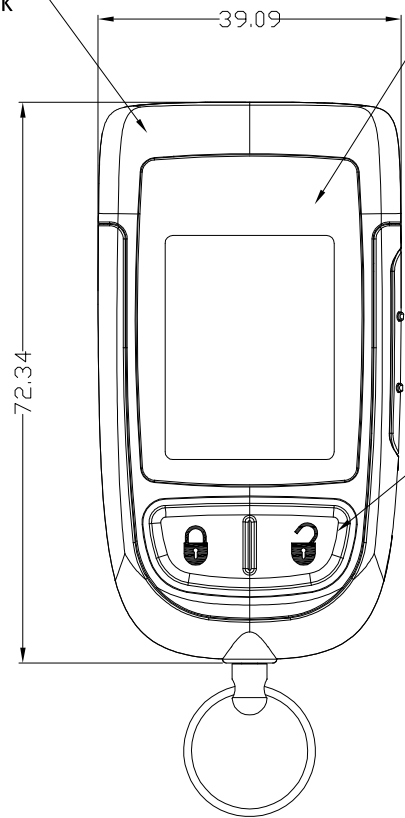

RUBBER COLOR:
MATTE BLACK
ICONS COLOR:
COOL GRAY 5U

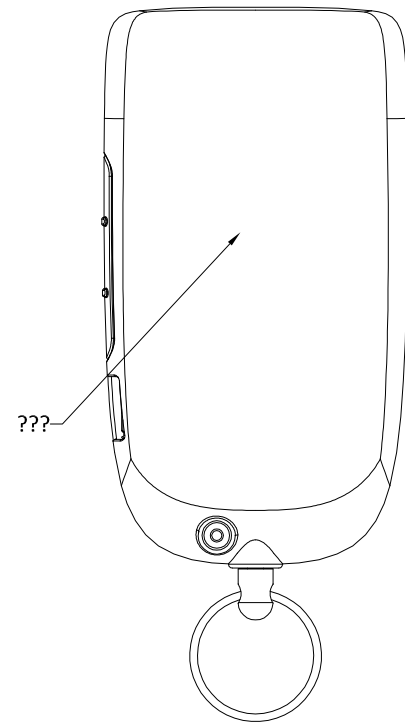
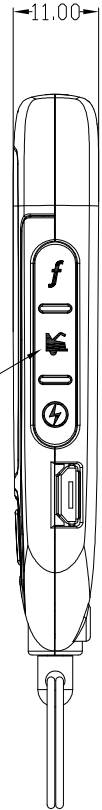

???

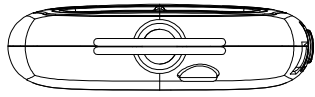

BODY MATERIAL : ABS+PC
1. Texture is same as MT-11010
2. Radius will be 0.2 if not specified.

*Tolerance please refer specification of tolerance limits "C"
INJECT TOLERANCE SPEC.

GRADE	A	B	C
UNDER 6	± 0.08	± 0.16	± 0.30
6~30	± 0.10	± 0.20	± 0.40
30~120	± 0.20	± 0.40	± 0.80
120~300	± 0.40	± 0.80	± 2.00

PART	P/N	PART	P/N
CASE	IASMO	MYLAR	NTWG3000
LENS	IRSMO	BAT. ADHESIVE	NTDH1C00
TOP KEY	NKSM0	ELASTOMER	NADG21AA
SIDE KEY	NKSM1	(+)CONTACT	MCWM1000
KEY CHAIN	MA160000	MYLAR TYPE	NTDN0000
SCREW	MIF17006	PORON TAPE	NTDG8000*2

SCALE: 1:1	UNIT: M/M	DRN BY Eason	DATE 2013/5/2	NUTEK CORPORATION			
MATERIAL	CHK BY YYS	5/7	TITLE PDRS-7504				
FINISH	APPD BY Victor	5/7	SIZE A4	DEPT	DRAWING NO 10110190	REV 1	
CODE	SHEET	OF					